



Booklet No. :

EI - 16

Instrumentation Engineering

Duration of Test : 2 Hours

Max. Marks : 120

Hall Ticket No.

--	--	--	--	--	--	--	--

Name of the Candidate : _____

Date of Examination : _____ OMR Answer Sheet No. : _____

Signature of the Candidate

Signature of the Invigilator

INSTRUCTIONS

1. This Question Booklet consists of **120** multiple choice objective type questions to be answered in **120** minutes.
2. Every question in this booklet has 4 choices marked (A), (B), (C) and (D) for its answer.
3. Each question carries **one** mark. There are no negative marks for wrong answers.
4. This Booklet consists of **24** pages. Any discrepancy or any defect is found, the same may be informed to the Invigilator for replacement of Booklet.
5. Answer all the questions on the OMR Answer Sheet using **Blue/Black ball point pen only**.
6. Before answering the questions on the OMR Answer Sheet, please read the instructions printed on the OMR sheet carefully.
7. OMR Answer Sheet should be handed over to the Invigilator before leaving the Examination Hall.
8. Calculators, Pagers, Mobile Phones, etc., are not allowed into the Examination Hall.
9. No part of the Booklet should be detached under any circumstances.
10. The seal of the Booklet should be opened only after signal/bell is given.

EI-16-A



INSTRUMENTATION ENGINEERING (EI)

1. A homogeneous system of equations $AX=0$ has a trivial solution if
 (A) $|A| \neq n$ (B) $|A| = 0$ (C) $|A| = n$ (D) $|A| \neq 0$

2. If 1, 2 and 3 are the eigen values of $A = \begin{bmatrix} 2 & 2 & 1 \\ 1 & 3 & 1 \\ 1 & 2 & 2 \end{bmatrix}$, then the eigen values of transpose of A are
 (A) 1, 2, 3 (B) 1, 1/2, 1/3 (C) 1, 1/2, 3 (D) 1.2.1/3

3. By changing the order of integration the integral $\int_0^{\infty} \int_{y=x}^{\infty} \frac{e^{-y}}{y} dy dx$ becomes
 (A) $\int_0^{\infty} \int_y^{\infty} \frac{e^{-y}}{y} dx dy$ (B) $\int_0^{\infty} \int_0^y \frac{e^{-y}}{y} dx dy$
 (C) $\int_0^{\infty} \int_0^{\infty} \frac{e^{-y}}{y} dx dy$ (D) $\int_0^{\infty} \int_{y=x}^{\infty} \frac{e^{-y}}{y} dx dy$

4. If $r = xi + yj + zk$ then the vector function $\frac{\vec{r}}{r^2}$ is
 (A) constant (B) solinoidal (C) unit vector (D) irrotational

5. One of the Cauchy Riemann condition in polar condition is
 (A) $\frac{\partial u}{\partial r} = -\frac{1}{r} \frac{\partial v}{\partial \theta}$ (B) $\frac{\partial u}{\partial r} = \frac{1}{r} \frac{\partial v}{\partial \theta}$ (C) $\frac{\partial u}{\partial \theta} = \frac{1}{r} \frac{\partial v}{\partial r}$ (D) $\frac{\partial u}{\partial \theta} = \frac{\partial v}{\partial r}$

6. The residue of $f(x) = \frac{z^2}{(z-1)^2(z+2)}$ at $z = -2$ is
 (A) $\frac{4}{9}$ (B) $\frac{5}{9}$ (C) $\frac{2}{3}$ (D) $\frac{1}{3}$

7. The particular integral of the differential equation $(D^2 + 4)y = \cos 2x$, where $D = \frac{d}{dx}$ is
 (A) $\frac{1}{2} \sin 2x$ (B) $\frac{1}{2} x \sin 2x$ (C) $\frac{1}{4} x \sin 2x$ (D) $\frac{1}{2} x \cos 2x$

Set - A

2

EI

8. The Laplace transform of $x^2 e^{2x}$
- (A) $\frac{2}{s^3}$ (B) $\frac{2}{(s+2)^3}$ (C) $\frac{2}{(s-2)^3}$ (D) $\frac{1}{s^3}$
9. The minimum value of Pearson coefficient of correlation is
- (A) 1 (B) 0 (C) -1 (D) $-\infty$
10. If X is binomially distributed random variable with probability distribution function $C_x^n (p)^x (1-p)^{n-x}$, then the variance is
- (A) \sqrt{np} (B) $\sqrt{np(1-p)}$ (C) np (D) $np(1-p)$
11. For open control system which of the following statements is incorrect?
- (A) Less expensive
 (B) Recalibration is not required for maintaining the required quality of the output
 (C) Construction is simple and maintenance easy
 (D) Errors are caused by disturbances
12. The steady state value of the output of the system for a unit impulse input applied at time instant $t = 1$ will be
- (A) 0 (B) 0.5 (C) 1 (D) 2
13. A control system working under unknown random actions is called
- (A) computer control system (B) digital data system
 (C) stochastic control system (D) adaptive control system
14.increases the steady state accuracy.
- (A) Integrator (B) Differentiator
 (C) Phase lead compensator (D) Phase lag compensator
15. As a result of introduction of negative feedback which of the following will not decrease ?
- (A) Band width (B) Overall gain (C) Distortion (D) Instability
16. Zero initial condition for a system means
- (A) input reference signal is zero
 (B) zero stored energy
 (C) no initial movement of moving parts
 (D) system is at rest and no energy is stored in any of its components

Set - **A**

17. Which of the following statements is correct for a system with gain margin close to unity or a phase margin close to zero?
- (A) The system is relatively stable (B) The system is highly stable
 (C) The system is highly oscillatory (D) None of the above
18. The position and velocity errors of a type-2 system are
- (A) constant, constant (B) constant, infinity
 (C) zero, constant (D) zero, zero
19. Phase margin of a system is used to specify which of the following?
- (A) Frequency response (B) Absolute stability
 (C) Relative stability (D) Time response
20. Addition of zeros in transfer function causes which of the following?
- (A) Lead-compensation (B) Lag-compensation
 (C) Lead-lag compensation (D) None of the above
21. In order to increase the damping of a badly underdamped system which of following compensators may be used?
- (A) Phase-lead (B) Phase-lag
 (C) Both (A) and (B) (D) Either (A) or (B)
22. A differentiator is usually not a part of a control system because it
- (A) reduces damping (B) reduces the gain margin
 (C) increases input noise (D) increases error
23. The characteristic equation of a closed-loop system is $s(s + 1)(s + 3)k(s + 2) = 0$, $k > 0$. Which of the following statements is true?
- (A) Its root are always real
 (B) It cannot have a breakaway point in the range $-1 < \text{Re}[s] < 0$
 (C) Two of its roots tend to infinity along the asymptotes $\text{Re}[s] = -1$
 (D) It may have complex roots in the right half plane

24. The polar plot of an open loop stable system is shown below. The closed loop system is

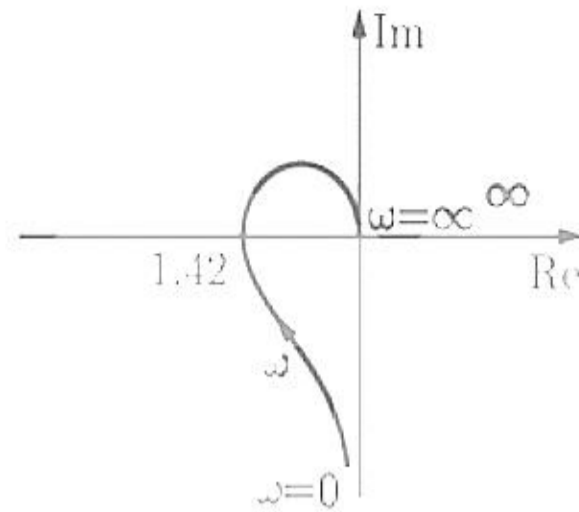

- (A) always stable
- (B) marginally stable
- (C) un-stable with one pole on the RH s -plane
- (D) un-stable with two poles on the RH s -plane.

25. The unit-step response of a unity feedback system with open loop transfer function $G(s) = K/((s + 1)(s + 2))$ is shown in the figure. The value of K is

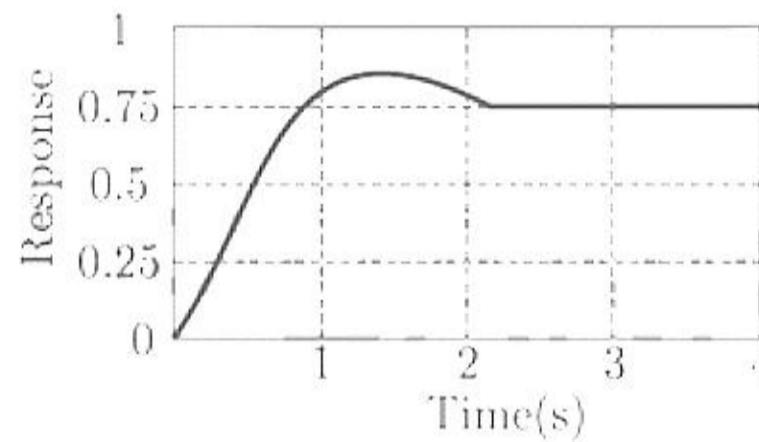

- (A) 0.5
- (B) 2
- (C) 4
- (D) 6

26. The bridge method commonly used for finding mutual inductance is

- (A) Heaviside Campbell bridge
- (B) Schering bridge
- (C) De Sauty bridge
- (D) Wien bridge

Set - A

27. For the circuit shown in the figure, the voltage and current expressions are $v(t) = E_1 \sin(\omega t) + E_3 \sin(3\omega t)$ and $i(t) = I_1 \sin(\omega t - \phi_1) + I_3 \sin(3\omega t - \phi_3) + I_5 \sin(5\omega t)$

The average power measured by the wattmeter is

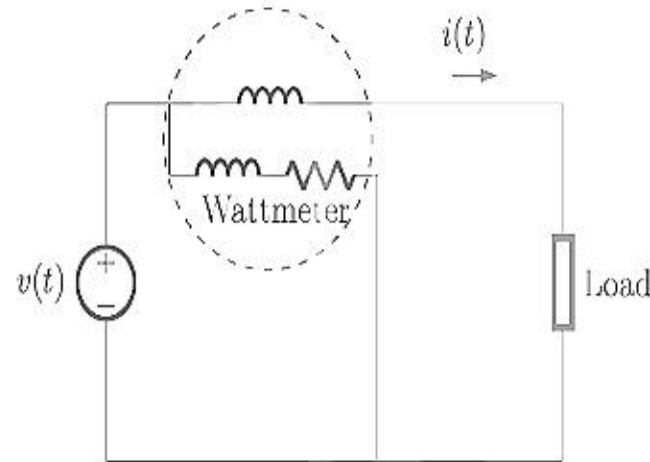

- (A) $\frac{1}{2} E_1 I_1 \cos \phi_1$ (B) $\frac{1}{2} [E_1 I_1 \cos \phi_1 + E_1 I_3 \cos \phi_3 + E_1 I_5]$
 (C) $\frac{1}{2} [E_1 I_1 \cos \phi_1 + E_3 I_3 \cos \phi_3]$ (D) $\frac{1}{2} [E_1 I_1 \cos \phi_1 + E_3 I_1 \cos \phi_1]$
28. An analog voltmeter uses external multiplier settings. With a multiplier setting of $20 \text{ k}\Omega$, it reads 440 V and with a multiplier setting of $80 \text{ k}\Omega$, it reads 352 V . For a multiplier setting of $40 \text{ k}\Omega$, the voltmeter reads
- (A) 371 V (B) 383 V (C) 394 V (D) 406 V
29. The bridge circuit shown in the figure below is used for the measurement of an unknown element Z_X . The bridge circuit is best suited when Z_X is a

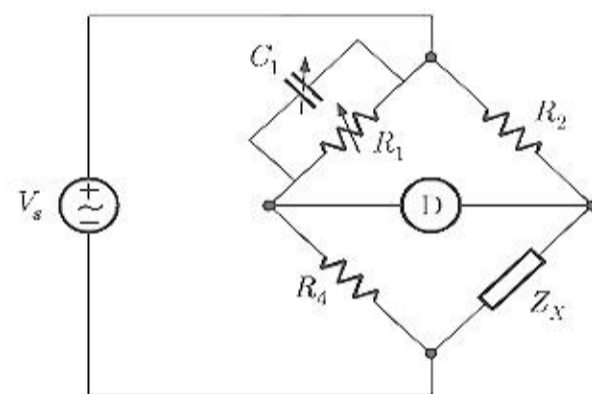

- (A) low resistance (B) high resistance
 (C) low Q inductor (D) lossy capacitor
30. A dual trace oscilloscope is set to operate in the alternate mode. The control input of the multiplexer used in the y-circuit is fed with a signal having a frequency equal to
- (A) the highest frequency that the multiplexer can operate properly
 (B) twice the frequency of the time base (sweep) oscillator
 (C) the frequency of the time base (sweep) oscillator
 (D) half the frequency of the time base (sweep) oscillator

Set - **A**

31. An ammeter has a current range of 0-5 A, and its internal resistance is 0.2Ω . In order to change the range to 0-25 A, we need to add a resistance of
- (A) 0.8Ω in series with the meter
 (B) 1.0Ω in series with the meter
 (C) 0.04Ω in parallel with the meter
 (D) 0.05Ω in parallel with the meter

32. A sampling wattmeter (that computes power from simultaneously sampled values of voltage and current) is used to measure the average power of a load. The peak to peak voltage of the square wave is 10 V and the current is a triangular wave of 5A p-p as shown in the figure. The period is 20 ms. The reading in W will be

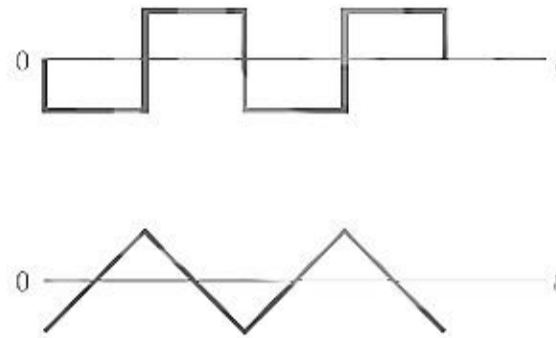

- (A) 0 W (B) 25 W (C) 50 W (D) 100 W
33. The minimum number of wattmeter(s) required to measure 3-phase, 2-wire balanced or unbalanced power is
- (A) 1 (B) 2 (C) 3 (D) 4
34. A $100 \mu\text{A}$ ammeter has an internal resistance of 100Ω . For extending its range to measure $500 \mu\text{A}$, the shunt required is of resistance (in Ω)
- (A) 20.0 (B) 22.22 (C) 25.0 (D) 50.0
35. Resistance R_1 and R_2 have, respectively, nominal values of 10Ω and 5Ω and tolerance of $\pm 5\%$ and $\pm 10\%$. The range of values for the parallel combination of R_1 and R_2 is
- (A) 3.077Ω to 3.636Ω (B) 2.805Ω to 3.371Ω
 (C) 3.237Ω to 3.678Ω (D) 3.192Ω to 3.435Ω
36. The pressure and velocity are the throat of a Venturi tube, measuring the flow of a liquid, are related to the upstream pressure and velocity, respectively, as follows:
- (A) Pressure is lower but velocity is higher
 (B) Pressure is higher but velocity is lower
 (C) Both pressure and velocity and velocity are lower
 (D) Pressure and velocity are identical

37. Semiconductor strain gages typically have much higher gage factors than those of metallic strain gages, primarily due to:
- (A) higher temperature sensitivity
 - (B) higher Poisson's ratio
 - (C) higher piezoresistive coefficient
 - (D) higher magnetostrictive coefficient
38. For the op-amp shown in the figure, the bias currents are $I_{b1} = 450 \text{ nA}$ and $I_{b2} = 350 \text{ nA}$. The values of the input bias current (I_b) and the input offset current (I_f) are

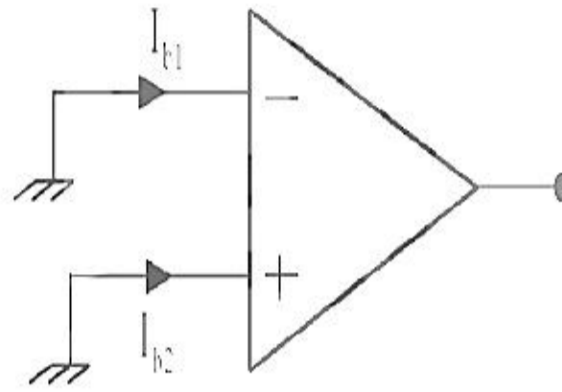

- (A) $I_b = 800 \text{ nA}$, $I_f = 50 \text{ nA}$
 - (B) $I_b = 800 \text{ nA}$, $I_f = 100 \text{ nA}$
 - (C) $I_b = 400 \text{ nA}$, $I_f = 50 \text{ nA}$
 - (D) $I_b = 400 \text{ nA}$, $I_f = 100 \text{ nA}$
39. A discrete-time signal $[n]$ is obtained by sampling an analog signal at 10 kHz. The signal $x[n]$ is filter by a system with impulse response $h[n] = 0.5\{\delta[n] + \delta[n-1]\}$. The 3dB cut-off frequency of the filter is
- (A) 1.25 kHz
 - (B) 2.50 kHz
 - (C) 4.00 kHz
 - (D) 5.00 kHz
40. A psychrometric chart is used to determine
- (A) pH
 - (B) Sound velocity in glasses
 - (C) CO_2 concentration
 - (D) Relative humidity
41. An LED emitting at $1 \mu\text{m}$ with a spectral width of 50 nm is used in a Michelson interferometer. To obtain a sustained interference, the maximum optical path difference between the two arms of the interferometer is
- (A) $200 \mu\text{m}$
 - (B) $20 \mu\text{m}$
 - (C) $1 \mu\text{m}$
 - (D) 50 nm
42. Light of wavelength 630 nm in vacuum, falling normally on a biological specimen of thickness $10 \mu\text{m}$, splits into two beams that are polarized at right angles. The refractive index of the tissue, for the two polarizations are 1.32 and 1.333. When the two beams emerge, they are out of phase by
- (A) 0.13°
 - (B) 74.3°
 - (C) 90.0°
 - (D) 128.6°

Set - **A**

8

EI

43. A linear variable differential transformer (LVDT) is
 (A) a displacement transducer
 (B) an impedance matching transformer
 (C) a differential temperature sensor
 (D) an auto transformer
44. Armature reaction in a synchronous motor at rated voltage and zero PF lead is
 (A) magnetizing (B) cross magnetizing
 (C) both (A) and (B) (D) demagnetizing
45. Match the different type of brain waves with their corresponding frequency ranges
 (i) Alpha wave – a. 4 – 8 Hz
 (ii) Beta wave – b. 0.5 – 4 Hz
 (iii) Theta wave – c. 8 – 13 Hz
 (iv) Delta wave – d. 13 – 30 Hz
 (A) (i) – b, (ii) – a, (iii) – c, (iv) – d
 (B) (i) – d, (ii) – b, (iii) – c, (iv) – a
 (C) (i) – c, (ii) – b, (iii) – a, (iv) – d
 (D) (i) – c, (ii) – d, (iii) – a, (iv) – b
46. Which of the following is not the characteristic of instrumentation amplifier?
 (A) High CMRR
 (B) High linearity
 (C) Low drift
 (D) High i/p impedance
47. A single phase air core transformer, fed from a rated sinusoidal supply, is operating at no load. The steady state magnetizing current drawn by the transformer from the supply will have the waveform

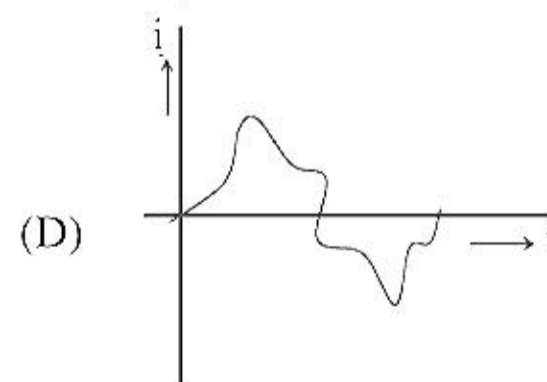
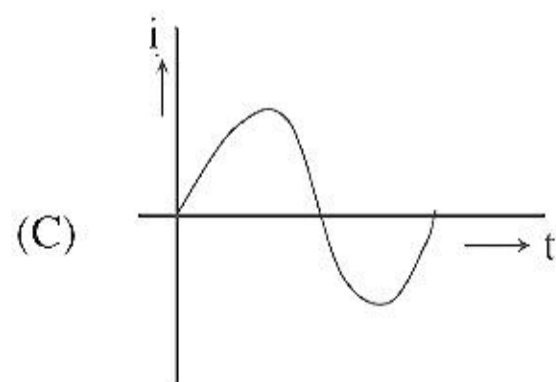
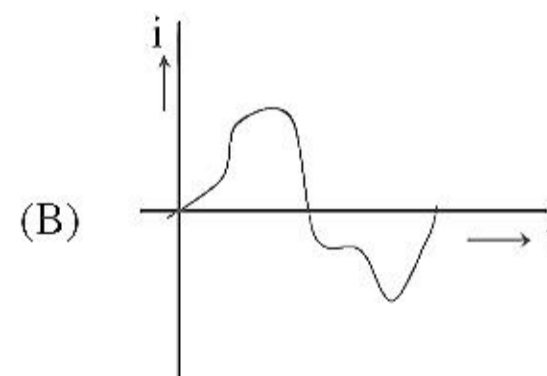
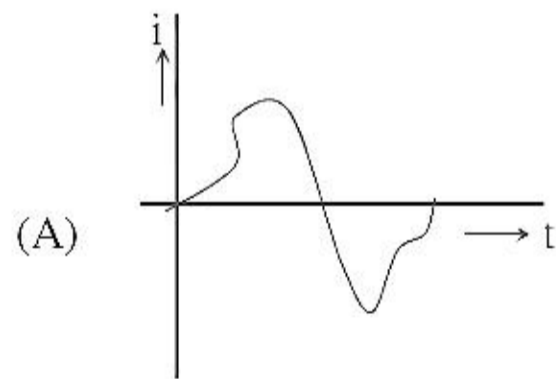

48. Match the Following :

- | | |
|------------------------|---------------------------------|
| P. Radiation Pyrometer | W. Angular velocity measurement |
| Q. Dall tube | X. Vacuum pressure measurement |
| R. Pirani gauge | Y. Flow measurement |
| S. Gyroscope | Z. Temperature measurement |

- (A) P-Z, Q-W, R-X, S-Y
 (B) P-Z, Q-Y, R-X, S-W
 (C) P-W, Q-X, R-Y, S-Z
 (D) P-Z, Q-X, R-W, S-Y

49. A piezoelectric type accelerometer has a sensitivity of 100mV/g. The transducer is subjected to a constant acceleration of 5g. The steady state output of the transducer will be

- (A) 0V (B) 100mV (C) 0.5V (D) 5V

50. A signal with frequency components 50Hz, 100Hz and 200Hz only is sampled at 150 samples/s. The ideally reconstructed signal will have frequency component(s)

- (A) 50Hz only (B) 75Hz only
 (C) 50Hz and 75Hz (D) 50Hz, 75Hz and 100Hz

51. For a periodic signal $v(t) = 30\sin 100t + 10\cos 300t + 6 \sin 500t + \pi/4$, the fundamental frequency in rad/s is

- (A) 100 (B) 300 (C) 500 (D) 1500

52. Assuming zero initial condition, the response $y(t)$ of the system given below to a unit step input $u(t)$ is

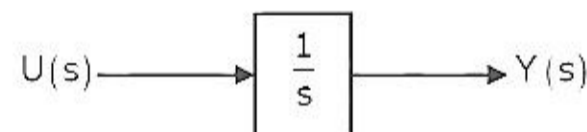

- (A) $u(t)$ (B) $t u(t)$ (C) $\frac{t^2}{2} u(t)$ (D) $e^t u(t)$

53. Considering the transformer to be ideal, the transmission parameter 'A' of the 2-port network shown in the figure below is

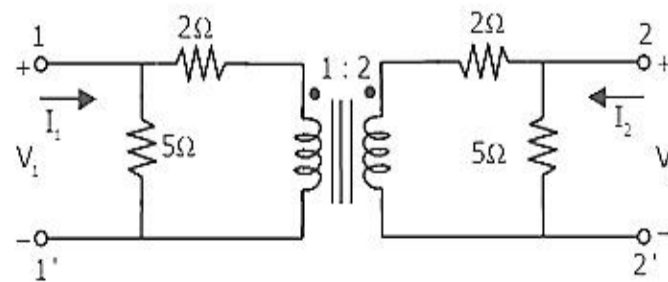

- (A) 1.3 (B) 1.4 (C) 0.5 (D) 2.0.

Set - **A**

60. Circuit turn-off time of an SCR is defined as the time
 (A) taken by the SCR turn of
 (B) required for the SCR current to become zero
 (C) for which the SCR is reverse biased by the commutation circuit
 (D) for which the SCR is reverse biased to reduced its current below the holding current
61. A 50% duty cycle square wave with zero mean is used as a baseband signal in an ideal frequency modulator with a sinusoidal carrier of frequency ω_c . The modulated signal is given as an input to an ideal phase demodulator (a circuit that produces an output proportional to the difference in phase of the modulated signal from that of the carrier). The output of the circuit is
 (A) a square wave
 (B) a train of impulses with alternating signs
 (C) a triangular wave
 (D) a sinusoidal wave
62. The input impedance of CRO is equivalent to a $1M\Omega$ resistance in parallel with a $45pF$ capacitance. It is used with a compensated 10-to-1 attenuation probe. The effective input capacitance at the probe tip is
 (A) $4.5pF$ (B) $5pF$ (C) $45pF$ (D) $450pF$
63. A galvanometer with internal resistance 100Ω and full-scale current $1mA$ is used to realize a dc voltmeter with a full scale range of $1V$. The full scale range of this voltmeter can be extended to $10V$ by connecting an external resistance of value
 (A) $9k\Omega$ (B) $9.9k\Omega$ (C) $10k\Omega$ (D) $11k\Omega$
64. In the circuit shown, the Zener diode has ideal characteristics and a breakdown voltage of $3.2V$. The output voltage V_o for an input voltage $V_i = +1V$ is closest to

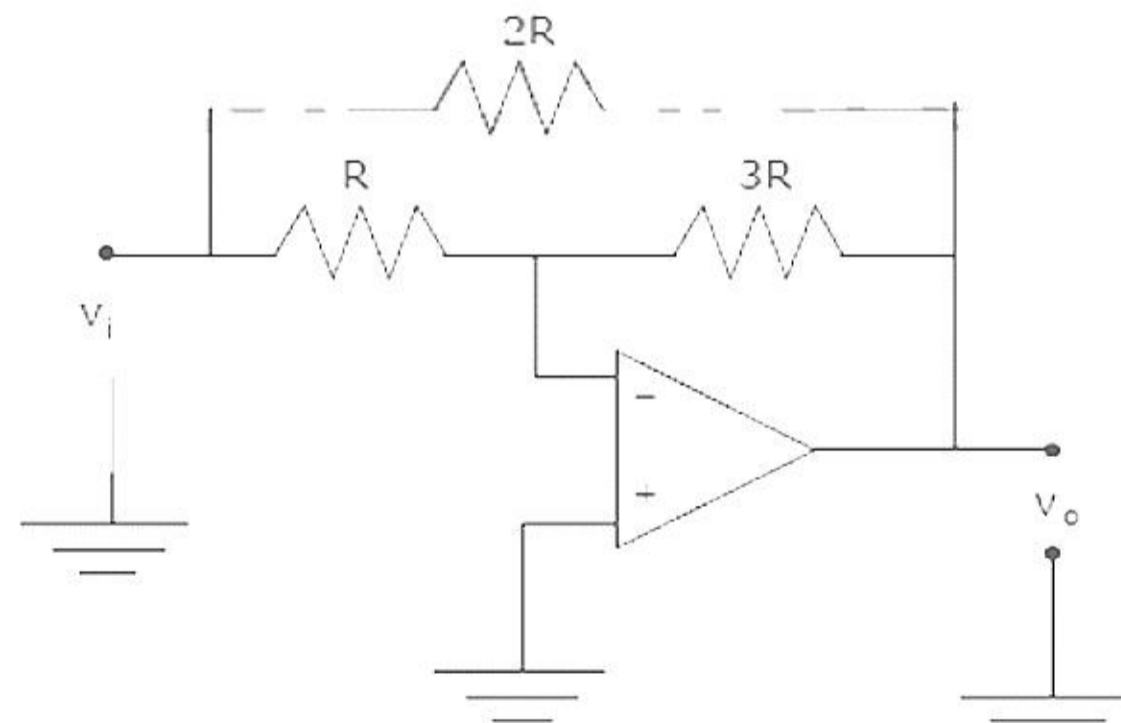

- (A) $-10V$ (B) $-6.6V$ (C) $-5V$ (D) $-3.2V$

Set - **A**

65. The efficiency of the source in the circuit when it transfers the maximum power to the load is

- (A) 100% (B) 50%
 (C) 200% (D) zero%

66. For input $x(t)$, an ideal impulse sampling system produces the output

$$Y(t) = \sum_{k=-\infty}^{\infty} (x(kt) + \delta(t - kt))$$

Where $\delta(t)$ is the Dirac delta function

- (A) nonlinear and time invariant
 (B) nonlinear and time varying
 (C) linear and time invariant
 (D) linear and time varying

67. A filter is represented by the signal flow graph shown in the figure. Its input $x(t)$ and output is $y(t)$. The transfer function of the filter is

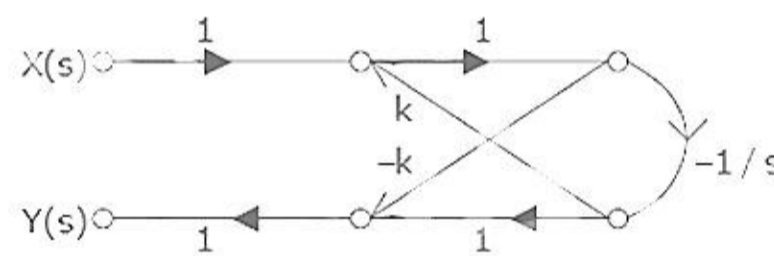

- (A) $\frac{-(1+ks)}{s+k}$ (B) $\frac{(1+ks)}{s+k}$ (C) $\frac{-(1-ks)}{s+k}$ (D) $\frac{(1-ks)}{s+k}$

68. A standard three-lead frontal plane ECG is taken of a person with a normal heart. The peak amplitude of the R-wave is

- (A) greatest in lead I (B) greatest in lead II
 (C) greatest in lead III (D) equal in all the leads

69. The output voltage of a transducer with an output resistance of $10\text{k}\Omega$ is connected to an amplifier. The minimum input resistance of the amplifier so that the error in recording the transducer output does not exceed 2% is

- (A) 10 $\text{k}\Omega$ (B) 49 $\text{k}\Omega$ (C) 490 $\text{k}\Omega$ (D) 1.2 $\text{M}\Omega$

70. In a balanced three phase circuit the line voltages are leading the phase voltages by

- (A) 30° (B) 60° (C) 90° (D) 120°

71. Two ammeters with full scale currents of 1 mA and 10 mA are connected in parallel and they read 0.25 mA and 2.5 mA respectively. Their internal resistances are in the ratio of
 (A) 1:10 (B) 10:1 (C) 1:5 (D) 5:1
72. Consider the z-transform $X(z) = 5z^2 + 4z^{-1} + 3$; $0 < |z| < \infty$. The inverse z-transform $x[n]$ is
 (A) $5\delta[n + 2] + 3\delta[n] + 4\delta[n - 1]$ (B) $5\delta[n - 2] + 3\delta[n] + 4\delta[n + 1]$
 (C) $5u[n + 2] + 3u[n] + 4u[n - 1]$ (D) $5u[n - 2] + 3u[n] + 4u[n + 1]$
73. Two discrete time systems with impulse responses $h_1[n] = \delta[n - 1]$ and $h_2[n] = \delta[n - 2]$ are connected in cascade. The overall impulse response of the cascaded system is
 (A) $\delta[n - 1] + \delta[n - 2]$ (B) $\delta[n - 4]$
 (C) $\delta[n - 3]$ (D) $\delta[n - 1] \delta[n - 2]$
74. Which of the following is hardware interrupts?
 (A) RST5.5, RST6.5, RST7.5 (B) INTR, TRAP
 (C) (A) & (B) (D) All of above
75. The CF is known as _____
 (A) carry flag (B) condition flag
 (C) common flag (D) single flag
76. The register AX is formed by grouping _____
 (A) AH & AL (B) BH & BL (C) CH & CL (D) DH & DL
77. The advantage of memory mapped I/O over I/O mapped I/O is,
 (A) Faster
 (B) Many instructions supporting memory mapped I/O
 (C) Require a bigger address decoder
 (D) All the above

Set - **A**

78. $\theta=0$ degree, $V=100\text{mm/s}$, $C=1500\text{m/s}$, a 2MHz ultrasonic beam is shifted in frequencies by about
 (A) 500 Hz (B) 267 Hz (C) 300 Hz (D) 290 Hz
79. Plethysmograph for measuring total lung capacity is based on
 (A) Electromagnetic conduction (B) Faraday's law of induced emf
 (C) Boyle's law (D) Flemings right hand rule
80. In _____ the cardiac vector is displayed along with magnitude and spatial orientation.
 (A) Phono cardiography (B) Electro cardiography
 (C) Ballisto cardiography (D) Vector cardiography
81. A physiological response to a current applied to the surface of the body that produces muscle contraction or tissue injury is called as
 (A) Macro shock (B) Micro shock (C) Diathermy (D) Defibrillator
82. The purpose of compensation for a thermocouple is
 (A) to decrease temperature sensitivity
 (B) to increase voltage output
 (C) to cancel unwanted voltage output of a thermocouple
 (D) used for high-temperature circuits
83. In the circuit shown below the op-amps are ideal. Then V_{out} in volts is

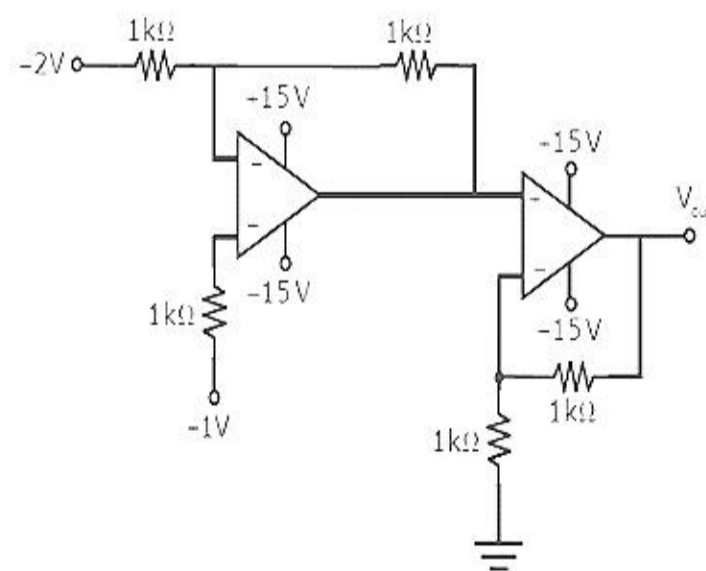

- (A) 4 (B) 6 (C) 8 (D) 10

Set - **A**

84. The discrete-time transfer function is $\frac{1-2Z^{-1}}{1-0.5Z^{-1}}$
- (A) Stable and of the minimum phase type
 (B) Stable and of the non-minimum phase type
 (C) Unstable and of the minimum phase type
 (D) Unstable and of the non-minimum phase type
85. The open-loop transfer function of a dc motor is given as $\frac{\omega(s)}{V_a(s)} = \frac{10}{1+10s}$. When connected in feedback as shown below, the approximate value of K_a that will reduce the time constant of the closed loop system by one hundred times as compared to that of the open-loop system is

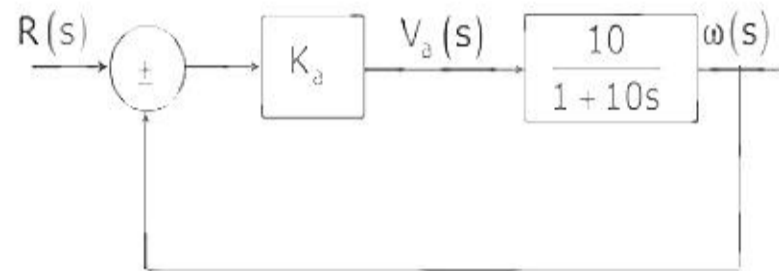

- (A) 1 (B) 5 (C) 10 (D) 100
86. Which of the following statements is NOT TRUE for a continuous time causal and stable LTI system?
- (A) All the poles of the system must lie on the left side of the $j\omega$ -axis
 (B) Zeros of the system can lie anywhere in the s -plane
 (C) All the poles must lie within $\sigma = -1$
 (D) All the roots of the characteristic equation must be located on the left side of the $j\omega$ -axis.
87. The Bode plot of a transfer function $G(s)$ is shown in the figure below.

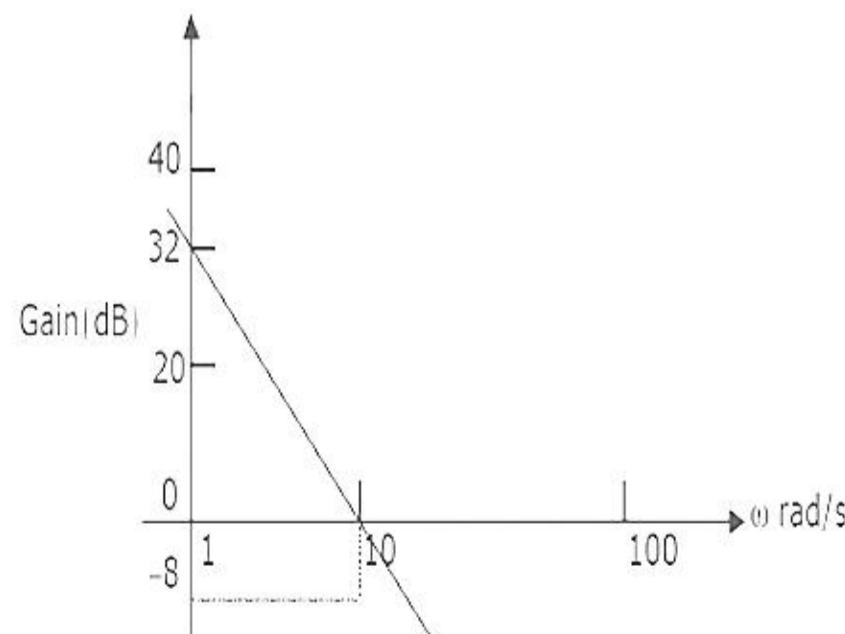

- The gain ($20 \log G(s)$) is 32dB and -8dB at 1 rad/s and 10 rad/s respectively. The phase is negative for all ω . Then $G(s)$ is
- (A) $39.8/s$ (B) $39.8/s^2$ (C) $32/s$ (D) $32/s^2$

88. If $V_A - V_B = 6 \text{ V}$, then $V_C - V_D$ is

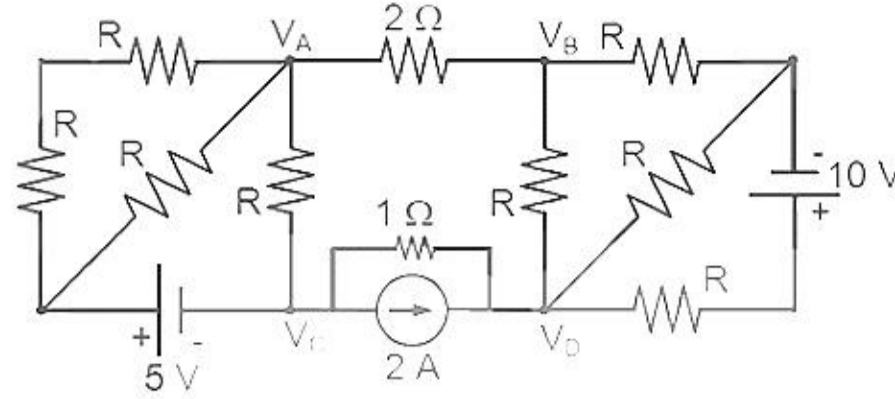

- (A) -5 V (B) 2 V (C) 3 V (D) 6 V

89. A periodic voltage waveform observed on an oscilloscope across a load is shown. A permanent magnet moving coil (PMMC) meter connected across the same load reads

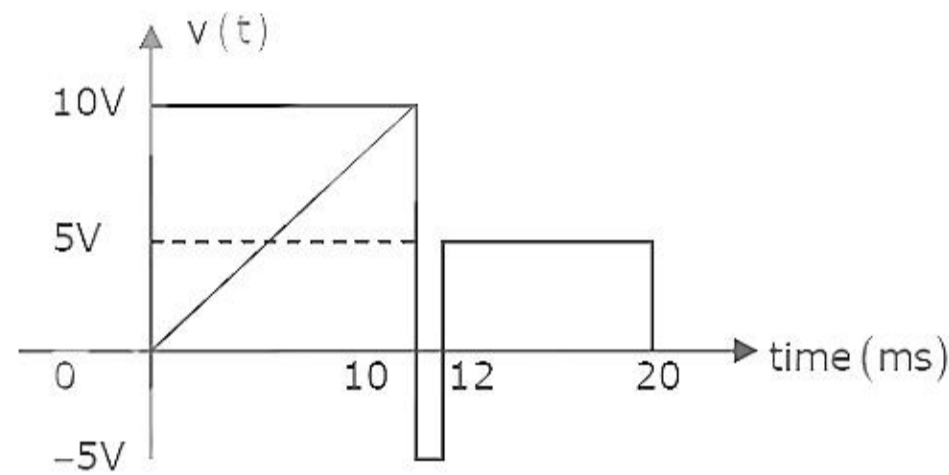

- (A) 4 V (B) 5 V (C) 8 V (D) 10 V

90. A DC ammeter has a resistance of 0.1Ω and its current range is $0-100 \text{ A}$. If the range is to be extended to $0-500 \text{ A}$, then meter required the following shunt resistance

- (A) 0.010Ω (B) 0.011Ω (C) 0.025Ω (D) 1.0Ω

91. In figure, the position of voltmeter and ammeter are exchanged. It may result in damage to

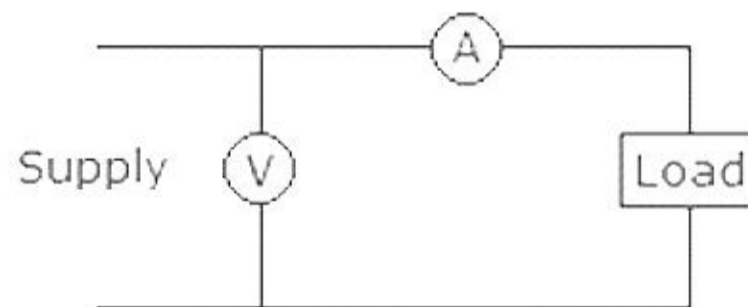

- (A) both the instruments (B) ammeter
(C) voltmeter (D) neither of two

92. When a unit step voltage drives a lag network the output
- (A) remains constant at unit step value
 - (B) increases exponentially from zero to final value
 - (C) decreases exponentially from 1 to 0
 - (D) either (B) or (C) depending on values of r and c
93. Regarding Ward-Leonard system of speed control which statement is false?
- (A) It is usually used where wide and very sensitive speed control is required
 - (B) It is used for motors having ratings from 750kW to 4000kW
 - (C) Capital outlay involved in the system is right since it uses two extra machines
 - (D) It gives a speed range of 10:1 but in one direction only
94. A closed-loop system has the characteristic function $(s^2 - 4)(s + 1) + K(s - 1) = 0$. Its root locus plot against K is

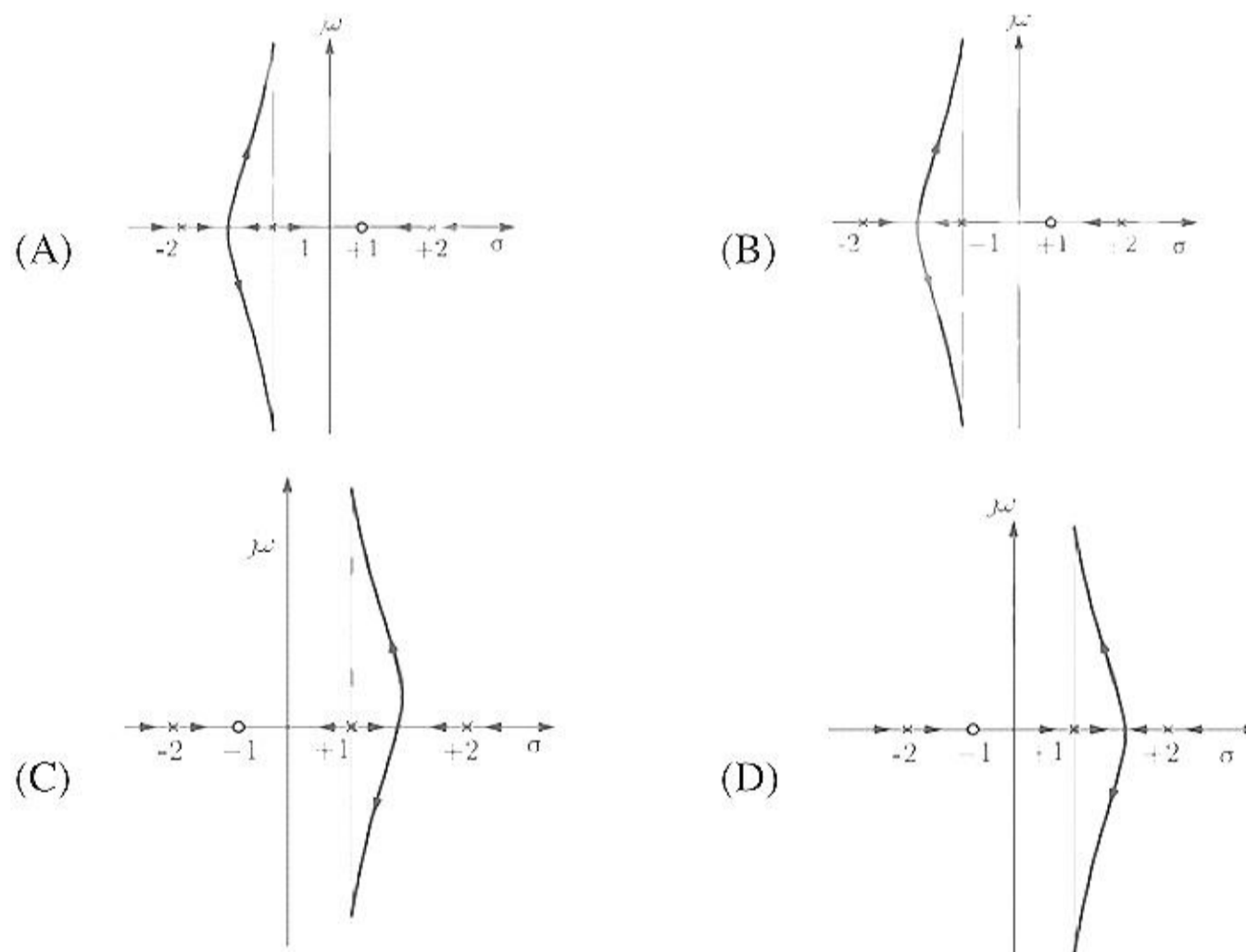

95. The slip of an induction motor normally does not depend on
- (A) rotor speed
 - (B) synchronous speed
 - (C) shaft torque
 - (D) core-loss component

Set - A

96. The output Y of a 2-bit comparator is logic 1, whenever the 2-bit input A is greater than the 2-bit input B . The number of combinations for which the output is logic 1, is
- (A) 4 (B) 6
(C) 8 (D) 10

97. In an 8085 microprocessor, the contents of the Accumulator, after the following instructions are executed will become

XRA A

MVI B, F0 H

SUB B

- (A) 01 H (B) 0F H (C) F0 H (D) 10 H

98. In the voltage doubler circuit shown in the figure, the switch ' S ' is closed at $t = 0$. Assuming diodes D_1 and D_2 to be ideal, load resistance to be infinite and initial capacitor voltages to be zero. The steady state voltage across capacitor C_1 and C_2 will be

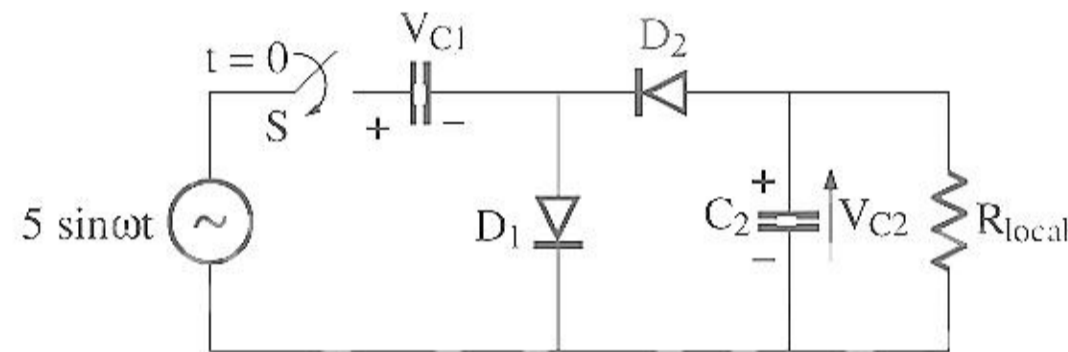

- (A) $V_{C1} = 10 \text{ V}$, $V_{C2} = 5 \text{ V}$ (B) $V_{C1} = 10 \text{ V}$, $V_{C2} = -5 \text{ V}$
(C) $V_{C1} = 5 \text{ V}$, $V_{C2} = 10 \text{ V}$ (D) $V_{C1} = 5 \text{ V}$, $V_{C2} = -10 \text{ V}$

99. A , B , C and D are input, and Y is the output bit in the XOR gate circuit of the figure below. Which of the following statements about the sum S of A , B , C , D and Y is correct ?

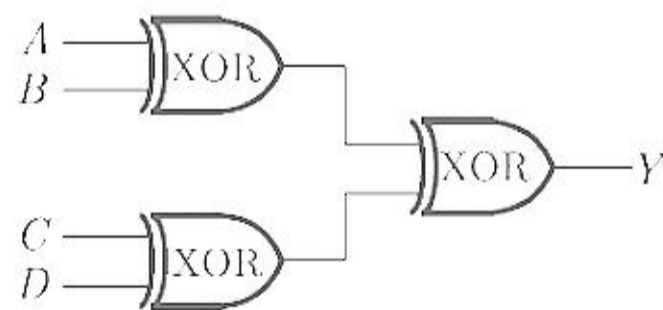

- (A) S is always with zero or odd
(B) S is always either zero or even
(C) $S = 1$ only if the sum of A , B , C and D is even
(D) $S = 1$ only if the sum of A , B , C and D is odd

Set - **A**

100. The Octal equivalent of HEX and number AB.CD is
 (A) 253.314 (B) 253.632 (C) 526.314 (D) 526.632

101. A 4×1 MUX is used to implement a 3-input Boolean function as shown in figure. The Boolean function $F(A,B,C)$ implemented is

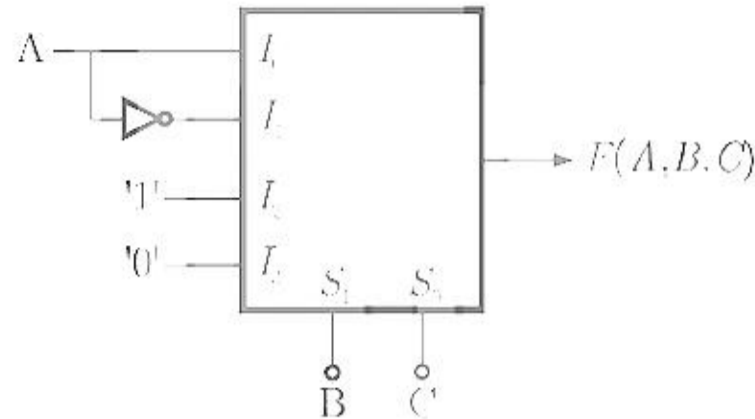

- (A) $F(A,B,C) = \Sigma(1,2,4,6)$ (B) $F(A,B,C) = \Sigma(1,2,6)$
 (C) $F(A,B,C) = \Sigma(2,4,5,6)$ (D) $F(A,B,C) = \Sigma(1,5,6)$

102. The digital circuit shown in the figure works as

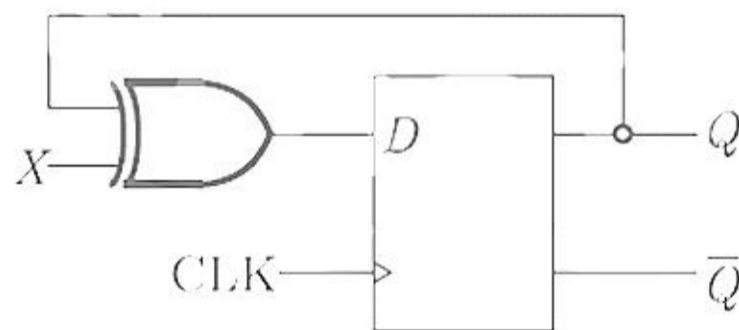

- (A) JK flip-flop (B) Clocked RS flip-flop
 (C) T flip-flop (D) Ring counter

103. The digital circuit using two inverters shown in figure will act as

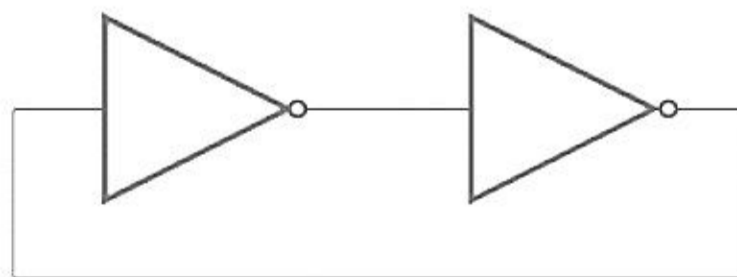

- (A) a bistable multi-vibrator (B) an astable multi-vibrator
 (C) a monostable multi-vibrator (D) an oscillator

104. The voltage comparator shown in figure can be used in the analog-to-digital conversion as

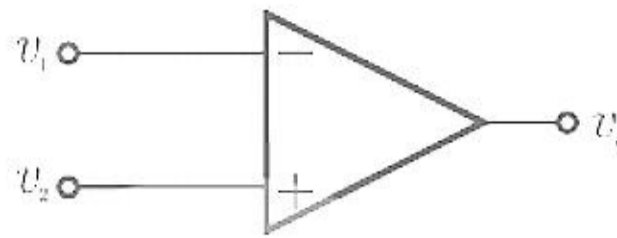

- (A) a 1-bit quantizer (B) a 2-bit quantizer
 (C) a 4-bit quantizer (D) a 8-bit quantizer
105. The variation of drain current with gate-to-source voltage ($I_D - V_{GS}$ characteristic) of a MOSFET is shown in figure. The MOSFET is

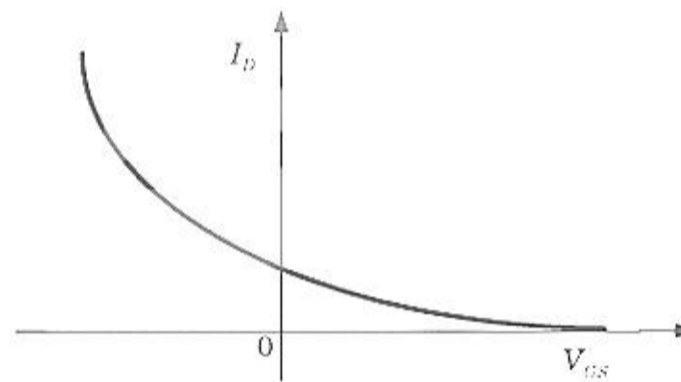

- (A) an n-channel depletion mode device
 (B) an n-channel enhancement mode device
 (C) an p-channel depletion mode device
 (D) an p-channel enhancement mode device
106. The boolean expression $\bar{X} Y \bar{Z} + \bar{X} \bar{Y} Z + X Y \bar{Z} + X \bar{Y} Z + X Y Z$ can be simplified to
- (A) $\bar{X} \bar{Z} + \bar{X} Z + Y Z$ (B) $X Y + \bar{Y} Z + Y \bar{Z}$
 (C) $\bar{X} Y + Y Z + X Z$ (D) $\bar{X} \bar{Y} + Y \bar{Z} + \bar{X} Z$
107. An X-Y flip-flop, whose Characteristic Table is given below is to be implemented using a J-K flip flop

X	Y	Q_{n+1}
0	0	1
0	1	Q_n
1	0	\bar{Q}_n
1	1	0

- (A) $J = X, K = \bar{Y}$ (B) $J = \bar{X}, K = Y$ (C) $J = Y, K = \bar{X}$ (D) $J = \bar{Y}, K = X$

108. In a communications system, noise is most likely to affect the signal
(A) at the transmitter (B) in the channel
(C) in the information source (D) at the destination
109. In a low-level AM system, amplifiers following the modulated stage must be
(A) linear devices (B) harmonic devices
(C) class C amplifiers (D) nonlinear devices
110. The modulation index of an AM wave is changed from 0 to 1. The transmitted power is
(A) unchanged (B) halved (C) doubled (D) increase by 50 percent
111. An FM signal with a modulation index m_f is passed through a frequency tripler. The wave in the output of the tripler will have a modulation index of
(A) $m_f/3$ (B) m_f (C) $3m_f$ (D) $9m_f$
112. A pre-emphasis circuit provides extra noise immunity by
(A) boosting the bass frequencies
(B) amplifying the higher audio frequencies
(C) pre amplifying the whole audio band
(D) converting the phase modulation to FM
113. One of the following is an indirect way of generating FM. This is the
(A) reactance FET modulator (B) varactor diode modulator
(C) Armstrong modulator (D) reactance bipolar transistor modulator
114. The Shannon-Hartley law
(A) refers to distortion (B) defines bandwidth
(C) describes signaling rates (D) refers to noise

115. The RS-232 interface
- (A) interconnects data sets and transmission circuit
 - (B) uses several different connectors
 - (C) permits custom wiring of signal lines to the connector pins as desired
 - (D) all of the above
116. As light is coupled in a multipoint reflective device, the power is reduced by
- (A) 1.5 dB
 - (B) 0.1 dB
 - (C) 0.5 dB
 - (D) 0.001 dB
117. Higher order TDM levels are obtained by
- (A) dividing pulse widths
 - (B) using the a-law
 - (C) using the μ -law
 - (D) forming super master groups
118. Indicate which of the following frequencies will not be found in the output of a normal TV receiver tuner
- (A) 4.5 MHz
 - (B) 41.25 MHz
 - (C) 45.75 MHz
 - (D) 42.17 MHz
119. Approximately what is the frequency limit of the optical fiber?
- (A) 20 GHz
 - (B) 1 MHz
 - (C) 100 MHz
 - (D) 40 MHz
120. The cladding which surrounds the fiber core
- (A) is used to reduce optical interference
 - (B) is used to protect the fiber
 - (C) acts to help guide the light in the core
 - (D) ensures that the refractive index remains constant

SPACE FOR ROUGH WORK

Set - A

24

EI

INSTRUMENTATION ENGINEERING (EI) SET-A

Question No	Answer	Question No	Answer
1	D	61	C
2	A	62	B
3	B	63	B
4	D	64	B
5	B	65	B
6	A	66	D
7	C	67	A
8	C	68	B
9	C	69	C
10	D	70	A
11	B	71	B
12	B	72	A
13	C	73	C
14	A	74	B
15	A	75	A
16	D	76	A
17	C	77	D
18	C	78	B
19	C	79	C
20	C	80	D
21	A	81	A
22	C	82	C
23	C	83	B
24	D	84	D
25	D	85	C
26	A	86	C
27	C	87	B
28	D	88	A
29	C	89	A
30	C	90	C
31	D	91	B
32	A	92	D
33	B	93	B
34	C	94	D
35	A	95	D
36	A	96	B
37	C	97	D
38	D	98	D
39	B	99	D
40	D	100	B

41	D	101	A
42	C	102	C
43	A	103	A
44	C	104	A
45	D	105	C
46	B	106	B
47	C	107	D
48	C	108	B
49	C	109	A
50	A	110	D
51	A	111	C
52	B	112	B
53	A	113	C
54	C	114	D
55	C	115	A
56	B	116	C
57	A	117	A
58	D	118	A
59	B	119	A
60	C	120	C