

Q.1 – Q.30 carry one mark each.

1. In Fig.Q1, the value of R is

- (a) 2.5Ω
 (b) 5.0Ω
 (c) 7.5Ω
 (d) 10.0Ω

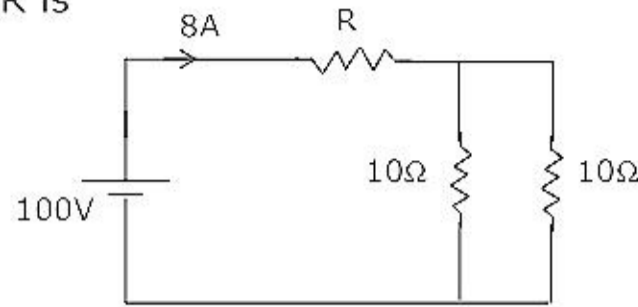

2. The RMS value of the voltage $u(t) = 3 + 4 \cos(3t)$ is:

- (a) $\sqrt{17}V$
 (b) $5V$
 (c) $7V$
 (d) $(3 + 2\sqrt{2})V$

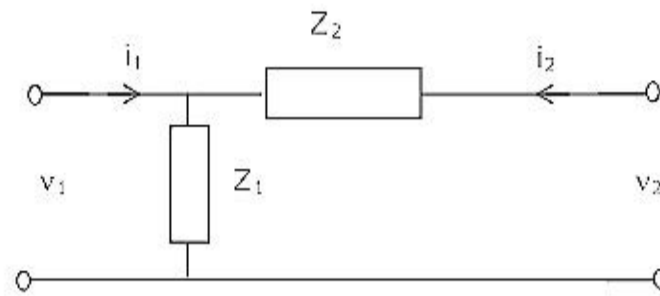

3. For the two-port network shown in Fig.Q3, the Z-matrix is given by

- (a) $\begin{bmatrix} Z_1 & Z_1 + Z_2 \\ Z_1 + Z_2 & Z_2 \end{bmatrix}$ (b) $\begin{bmatrix} Z_1 & Z_1 \\ Z_1 + Z_2 & Z_2 \end{bmatrix}$
 (c) $\begin{bmatrix} Z_1 & Z_2 \\ Z_2 & Z_1 + Z_2 \end{bmatrix}$ (d) $\begin{bmatrix} Z_1 & Z_1 \\ Z_1 & Z_1 + Z_2 \end{bmatrix}$

4. In Fig.Q4, the initial capacitor voltage is zero. The switch is closed at $t = 0$. the final steady-state voltage across the capacitor is:

- (a) $20V$
 (b) $10V$
 (c) $5V$
 (d) $0V$

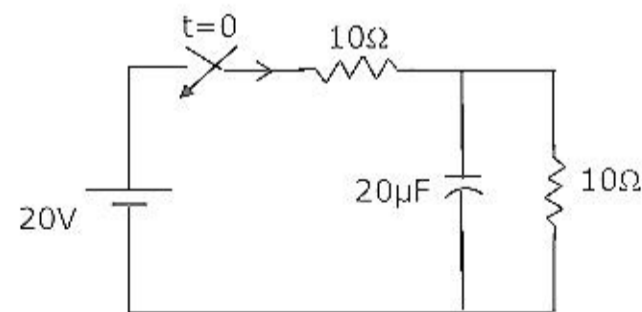

5. If \vec{E} is the electric field intensity, $\nabla \cdot (\nabla \times \vec{E})$ is equal to

- (a) \vec{E} (b) $|\vec{E}|$
 (c) null vector (d) zero

6. A system with zero initial conditions has the closed loop transfer function

$T(s) = \frac{s^2 + 4}{(s + 1)(s + 4)}$. The system output is zero at the frequency

- (a) 0.5 rad/sec. (b) 1 rad/sec. (c) 2 rad/sec. (d) 4 rad/sec.

7. Fig.Q7 shows the root locus plot (location of poles not given) of a third order system whose open loop transfer function is:

- (a) $\frac{K}{s^3}$
 (b) $\frac{K}{s^2(s+1)}$
 (c) $\frac{K}{s(s^2+1)}$
 (d) $\frac{K}{s(s^2-1)}$

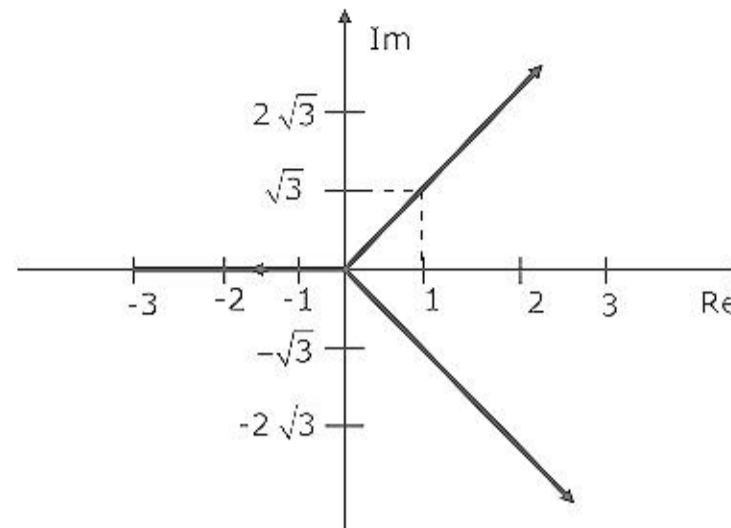

8. The gain margin of a unity feedback control system with the open loop transfer function $G(s) = \frac{(s+1)}{s^2}$ is:

- (a) 0 (b) $\frac{1}{\sqrt{2}}$ (c) $\sqrt{2}$ (d) ∞

9. In the matrix equation $Px = q$, which of the following is a necessary condition for the existence of at least one solution for the unknown vector x :

- (a) Augmented matrix $[P \ q]$ must have the same rank as matrix P
 (b) Vector q must have only non-zero elements
 (c) Matrix P must be singular
 (d) Matrix P must be square

10. If P and Q are two random events, then the following is TRUE:

- (a) Independence of P and Q implies that probability $(P \cap Q) = 0$
 (b) Probability $(P \cup Q) \geq$ Probability $(P) +$ Probability (Q)
 (c) If P and Q are mutually exclusive, then they must be independent
 (d) Probability $(P \cap Q) \leq$ Probability (P)

11. If $S = \int_1^{\infty} x^{-3} dx$, then S has the value

- (a) $\frac{-1}{3}$ (b) $\frac{1}{4}$ (c) $\frac{1}{2}$ (d) 1

12. The solution of the first order differential equation $\dot{x}(t) = -3x(t)$, $x(0) = x_0$ is:
- (a) $x(t) = x_0 e^{-3t}$ (b) $x(t) = x_0 e^{-3}$ (c) $x(t) = x_0 e^{\frac{-t}{3}}$ (d) $x(t) = x_0 e^{-t}$
13. The equivalent circuit of a transformer has leakage reactance X_1, X_2' and magnetizing reactance X_M . Their magnitudes satisfy
- (a) $X_1 \neq X_2' \neq X_M$ (b) $X_1 \neq X_2' = X_M$ (c) $X_1 = X_2' \neq X_M$ (d) $X_1 = X_2' = X_M$
14. Which three-phase connection can be used in a transformer to introduce a phase difference of 30° between its output and corresponding input line voltages
- (a) Star - Star (b) Star - Delta (c) Delta - Delta (d) Delta - Zigzag
15. On the torque/speed curve of induction motor shown in Fig.Q15, four points of operation are marked as W, X, Y and Z. Which one of them represents the operation at a slip greater than 1?

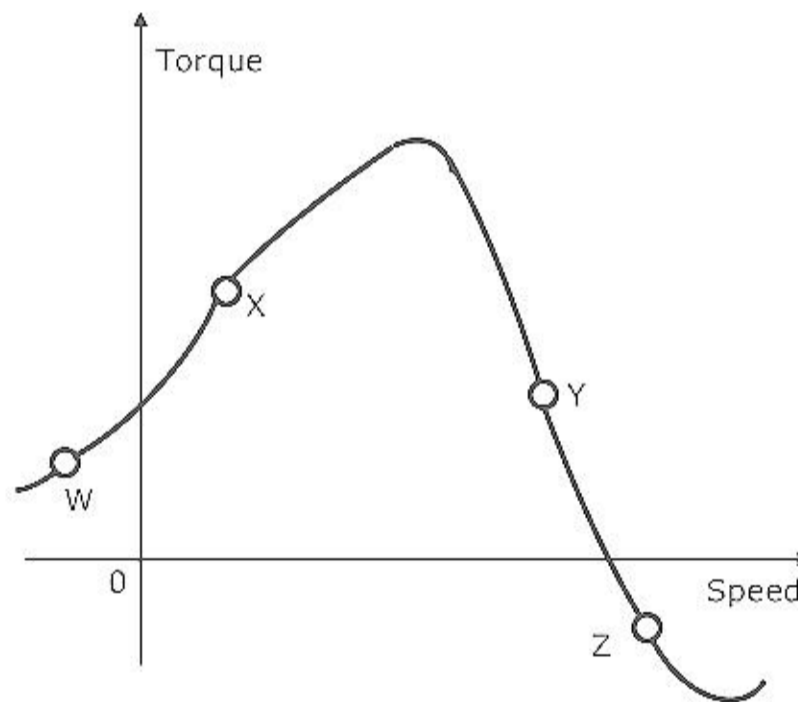

- (a) W (b) X (c) Y (d) Z
16. For an induction motor, operating at a slip s , the ratio of gross power output to air gap power is equal to:
- (a) $(1-s)^2$ (b) $(1-s)$ (c) $\sqrt{1-s}$ (d) $(1-\sqrt{s})$
17. The p.u. parameters for a 500 MVA machine on its own base are:
inertia $M = 20$ p.u.; reactance $X = 2$ p.u.
The p.u. values of inertia and reactance on 100 MVA common base, respectively, are
- (a) 4, 0.4 (b) 100, 10 (c) 4, 10 (d) 100, 0.4

18. An 800 kV transmission line has a maximum power transfer capacity on the operated at 400 kV with the series reactance unchanged, the new maximum power transfer capacity is approximately
- (a) P (b) $2P$ (c) $\frac{P}{2}$ (d) $\frac{P}{4}$
19. The insulation strength of an EHV transmission line is mainly governed by
- (a) load power factor (b) switching over-voltages
(c) harmonics (d) corona
20. High Voltage DC (HVDC) transmission is mainly used for
- (a) bulk power transmission over very long distances
(b) inter-connecting two systems with the same nominal frequency
(c) eliminating reactive power requirement in the operation
(d) minimizing harmonics at the converter stations
21. The Q-meter works on the principle of
- (a) mutual inductance (b) self inductance
(c) series resonance (d) parallel resonance
22. A PMMC voltmeter is connected across a series combination of a DC voltage source $V_1 = 2V$ and an AC voltage source $v_2(t) = 3 \sin(4t)V$. The meter reads
- (a) 2V (b) 5V (c) $\left(2 + \frac{\sqrt{3}}{2}\right)V$ (d) $\left(\frac{\sqrt{17}}{2}\right)V$

23. Assume that D_1 and D_2 in Fig.Q23 are ideal diodes. The value of current I is:

- (a) 0 mA
(b) 0.5 mA
(c) 1 mA
(d) 2 mA

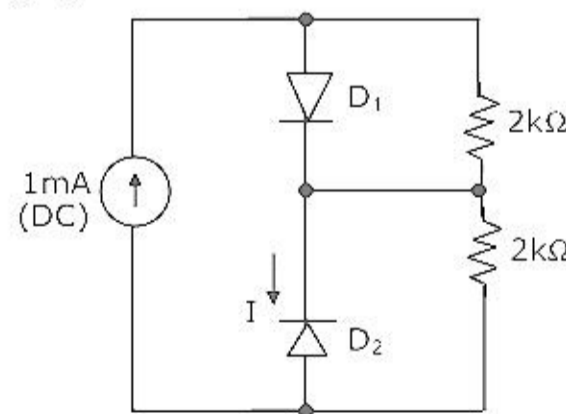

24. The 8085 assembly language instruction that stores the contents of H and L registers into the memory locations 2050_H and 2051_H , respectively, is:
- (a) SPHL 2050_H (b) SPHL 2051_H (c) SHLD 2050_H (d) STAX 2050_H

25. Assume that the N-channel MOSFET shown in Fig.Q25 is ideal, and that its threshold voltage is +1.0V. The voltage V_{ab} between nodes a and b is:

- (a) 5V
 (b) 2V
 (c) 1V
 (d) 0V

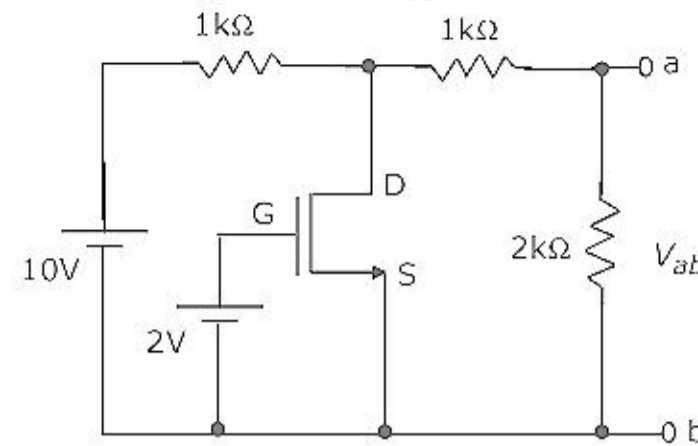

26. The digital circuit shown in Fig.Q26 works as a

- (a) JK flip-flop
 (b) Clocked RS flip-flop
 (c) T flip-flop
 (d) Ring counter

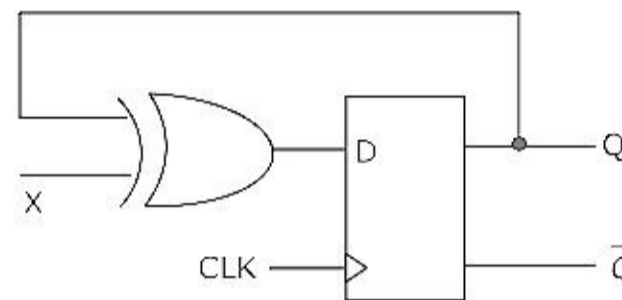

27. A digital-to-analog converter with a full-scale output voltage of 3.5V has a resolution close to 14 mV. Its bit size is:

- (a) 4 (b) 8 (c) 16 (d) 32

28. The conduction loss versus device current characteristic of a power MOSFET is best approximated by

- (a) a parabola (b) a straight line
 (c) a rectangular hyperbola
 (d) an exponentially decaying function

29. A three-phase diode bridge rectifier is fed from a 400V RMS, 50 Hz, three-phase AC source. If the load is purely resistive, the peak instantaneous output voltage is equal to

- (a) 400 V (b) $400\sqrt{2}$ V (c) $400\sqrt{\frac{2}{3}}$ V (d) $\frac{400}{\sqrt{3}}$ V

30. The output voltage waveform of a three-phase square-wave inverter contains

- (a) only even harmonics (b) both odd and even harmonics
 (c) only odd harmonics (d) only triplen harmonics

Q.31 – Q.80 carry two marks each

31. The RL circuit of Fig.Q31 is fed from a constant magnitude, variable frequency sinusoidal voltage source V_{IN} . At 100 Hz, the R and L elements each have a voltage drop U_{RMS} . If the frequency of the source is changed to 50 Hz, the new voltage drop across R is:

- (a) $\sqrt{\frac{5}{8}}U_{RMS}$ (b) $\sqrt{\frac{2}{3}}U_{RMS}$
 (c) $\sqrt{\frac{8}{5}}U_{RMS}$ (d) $\sqrt{\frac{3}{2}}U_{RMS}$

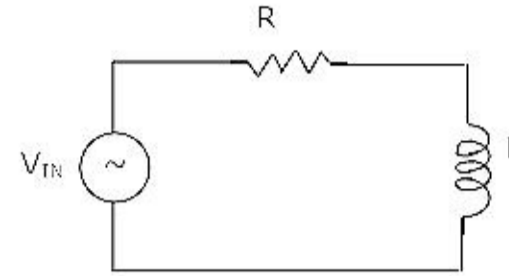

32. For the three-phase circuit shown in Fig.Q32, the ratio of the current $I_g : I_Y : I_B$ is given by

- (a) $1 : 1 : \sqrt{3}$ (b) $1 : 1 : 2$
 (c) $1 : 1 : 0$ (d) $1 : 1 : \sqrt{\frac{3}{2}}$

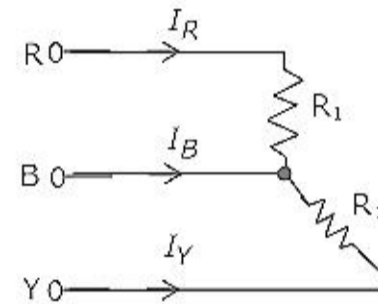

33. For the triangular waveform shown in Fig.Q33, the RMS value of the voltage is equal to

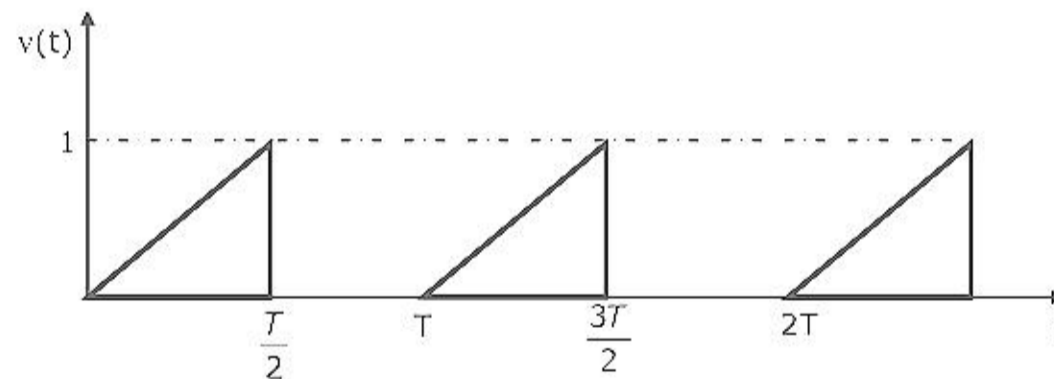

- (a) $\sqrt{\frac{1}{6}}$ (b) $\sqrt{\frac{1}{3}}$ (c) $\frac{1}{3}$ (d) $\sqrt{\frac{2}{3}}$

34. The circuit shown in Fig.Q34 is in steady state, when the switch is closed at $t = 0$. Assuming that the inductance is ideal, the current through the inductor at $t = 0^+$ equals

- (a) 0 A
 (b) 0.5 A
 (c) 1 A
 (d) 2 A

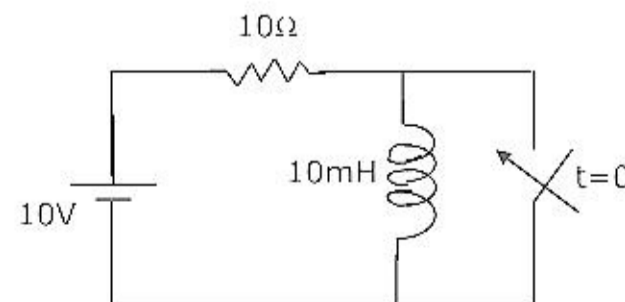

35. The charge distribution in a metal-dielectric-semiconductor specimen is shown in Fig.Q35. The negative charge density decreases linearly in the semiconductor as shown. The electric field distribution is as shown in

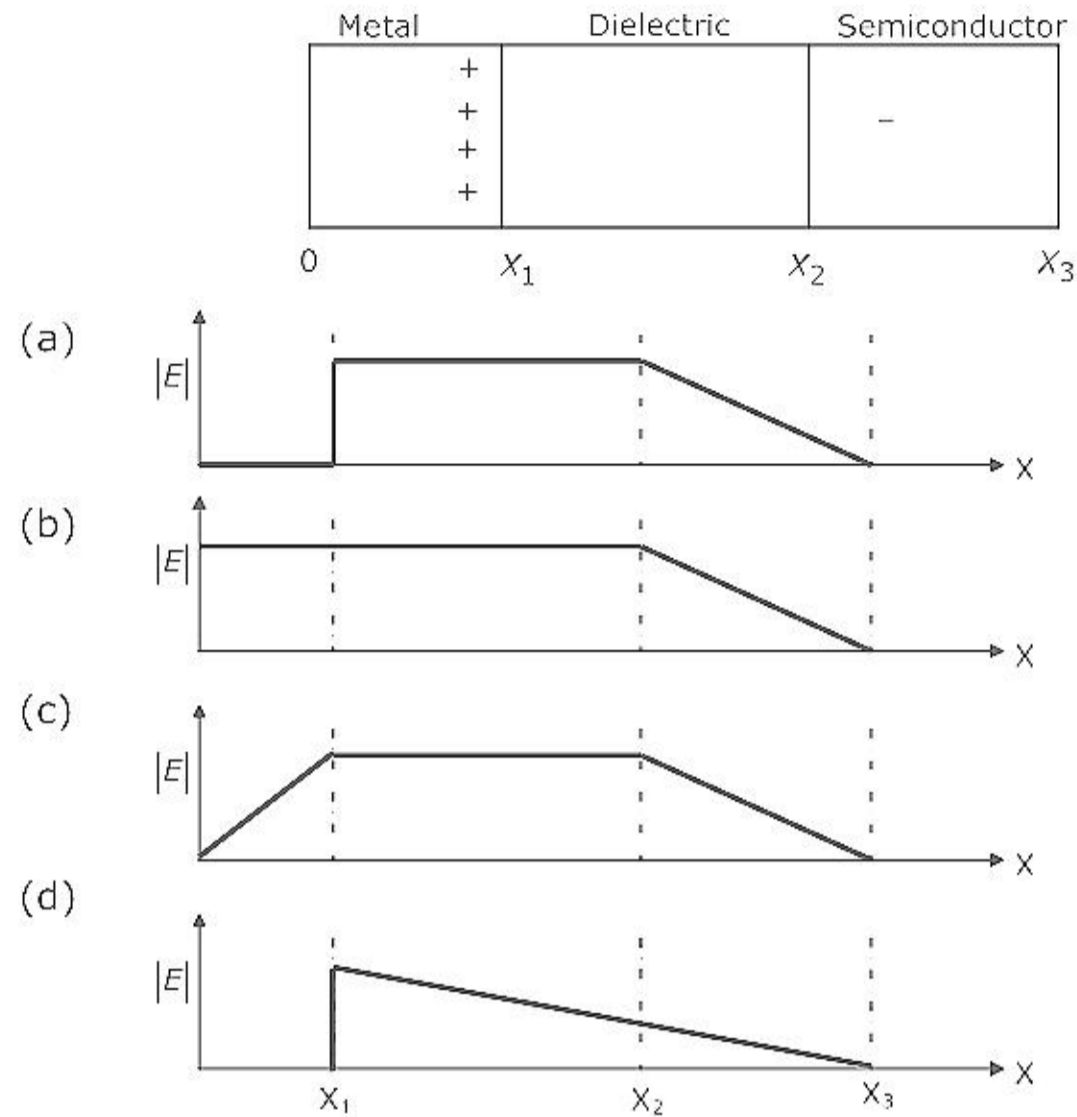

36. In Fig.Q36, the Thevenin's equivalent pair (voltage, impedance), as seen at the terminals P-Q, is given by

- (a) (2V, 5Ω)
- (b) (2V, 7.5Ω)
- (c) (4V, 5Ω)
- (d) (4V, 7.5Ω)

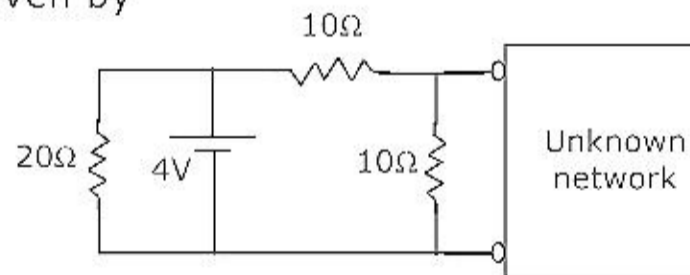

37. A unity feedback system, having an open loop gain

$$G(s)H(s) = \frac{K(1-s)}{(1+s)}, \text{ becomes stable when}$$

- (a) $|K| > 1$
- (b) $K > 1$
- (c) $|K| < 1$
- (d) $K < -1$

38. When subjected to a unit step input, the closed loop control system shown in Fig.Q38 will have a steady state error of

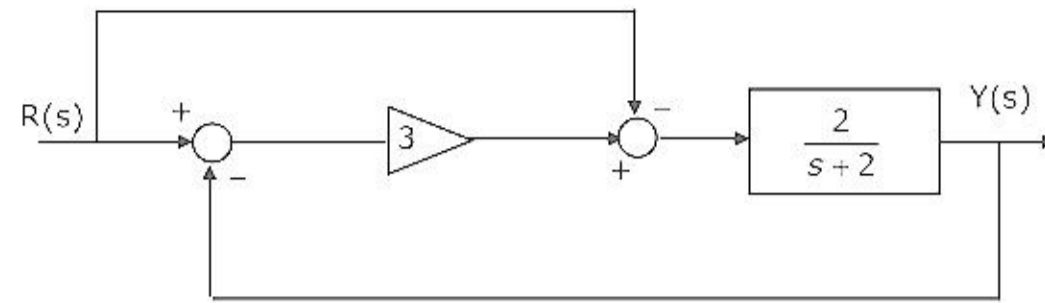

- (a) -1.0 (b) -0.5 (c) 0 (d) 0.5

39. In the GH(s) plane, the Nyquist plot of the loop transfer function

$$G(s)H(s) = \frac{\pi e^{-0.25s}}{s}$$

passes through the negative real axis at the point

- (a) (-0.25,j0) (b) (-0.5,j0) (c) (-1,j0) (d) (-2,j0)

40. If the compensated system shown in Fig.Q40 has a phase margin of 60° at the crossover frequency of 1 rad/sec, the value of the gain K is:

- (a) 0.366
(b) 0.732
(c) 1.366
(d) 2.738

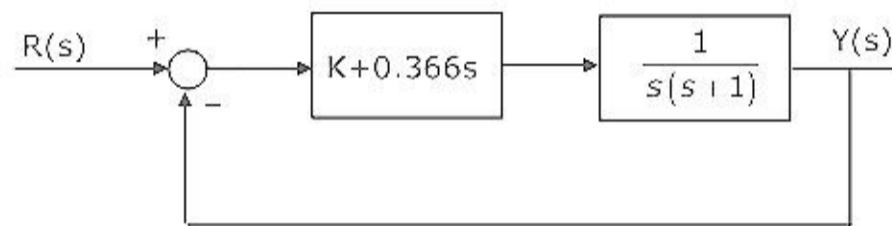

41. For the matrix

$$P = \begin{bmatrix} 3 & -2 & 2 \\ 0 & -2 & 1 \\ 0 & 0 & 1 \end{bmatrix},$$

one of the eigen values is equal to -2. Which of the following is an eigen vector?

- (a) $\begin{bmatrix} 3 \\ -2 \\ 1 \end{bmatrix}$ (b) $\begin{bmatrix} -3 \\ 2 \\ -1 \end{bmatrix}$ (c) $\begin{bmatrix} 1 \\ -2 \\ 3 \end{bmatrix}$ (d) $\begin{bmatrix} 2 \\ 5 \\ 0 \end{bmatrix}$

42. If

$$R = \begin{bmatrix} 1 & 0 & -1 \\ 2 & 1 & -1 \\ 2 & 3 & 2 \end{bmatrix},$$

the top row of R^{-1} is:

- (a) $[5 \ 6 \ 4]$ (b) $[5 \ -3 \ 1]$ (c) $[2 \ 0 \ -1]$ (d) $\left[2 \ -1 \ \frac{1}{2}\right]$

43. A fair coin is tossed three times in succession. If the first toss produces a head, then the probability of getting exactly two heads in three tosses is:
- (a) $\frac{1}{8}$ (b) $\frac{1}{2}$ (c) $\frac{3}{8}$ (d) $\frac{3}{4}$
44. For the function $f(x) = x^2 e^{-x}$, the maximum occurs when x is equal to:
- (a) 2 (b) 1 (c) 0 (d) -1
45. For the scalar field
 $u = \frac{x^2}{2} + \frac{y^2}{3}$, the magnitude of the gradient at the point (1,3) is:
- (a) $\sqrt{\frac{13}{9}}$ (b) $\sqrt{\frac{9}{2}}$ (c) $\sqrt{5}$ (d) $\frac{9}{2}$
46. For the equation $\ddot{x}(t) + 3\dot{x}(t) + 2x(t) = 5$, the solution $x(t)$ approaches the following values at $t \rightarrow \infty$
- (a) 0 (b) $\frac{5}{2}$ (c) 5 (d) 10
47. The Laplace transform of a function $f(t)$ is
 $F(s) = \frac{5s^2 + 23s + 6}{s(s^2 + 2s + 2)}$. As $t \rightarrow \infty$, $f(t)$ approaches
- (a) 3 (b) 5 (c) $\frac{17}{2}$ (d) ∞
48. The Fourier series for the function $f(x) = \sin^2 x$ is:
- (a) $\sin x + \sin 2x$ (b) $1 - \cos 2x$
(c) $\sin 2x + \cos 2x$ (d) $0.5 - 0.5 \cos 2x$
49. If $u(t)$ is the unit step and $\delta(t)$ is the unit impulse function, the inverse z-transform of $F(z) = \frac{1}{z+1}$ for $k \geq 0$ is:
- (a) $(-1)^k \delta(k)$ (b) $\delta(k) - (-1)^k$ (c) $(-1)^k u(k)$ (d) $u(k) - (-1)^k$

50. Two magnetic poles revolve around a stationary armature carrying two coils ($c_1 - c'_1, c_2 - c'_2$) as shown in Fig.Q50. Consider the instant when the poles are in a position as shown. Identify the correct statement regarding the polarity of the induced emf at this instant in coil sides c_1 and c_2 .

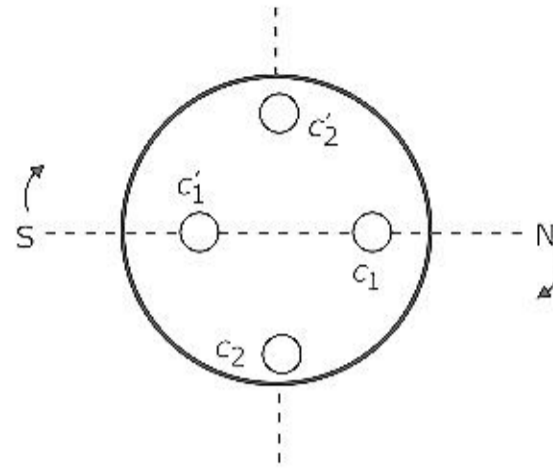

- (a) \odot in c_1 , no emf in c_2 (b) \otimes in c_1 , no emf in c_2
- (c) \odot in c_2 , no emf in c_1 (d) \otimes in c_2 , no emf in c_1
51. A 50 kW dc shunt motor is loaded to draw rated armature current at any given speed. When driven (i) at half the rated speed by armature voltage control and (ii) at 1.5 times the rated speed by field control, the respective output powers delivered by the motor are approximately
- (a) 25 kW in (i) and 75 kW in (ii) (b) 25 kW in (i) and 50 kW in (ii)
- (c) 50 kW in (i) and 75 kW in (ii) (d) 50 kW in (i) and 50 kW in (ii)
52. In relation to DC machines, match the following and choose the correct combination.

Group - 1
Performance Variables

- (P) Armature emf (E)
(Q) Developed torque (T)
(R) Developed power (P)

Group - 2
Proportional to

- (1) Flux (ϕ), speed (ω) and armature current (I_a)
(2) ϕ and ω only
(3) ϕ and I_a only
(4) I_a and ω only
(5) I_a only

- (A) P - 3 Q - 3 R - 1
(B) P - 2 Q - 5 R - 4
(C) P - 3 Q - 5 R - 4
(D) P - 2 Q - 3 R - 1

53. In relation to the synchronous machines, which one of the following statements is false?
- (a) In salient pole machines, the direct-axis synchronous reactance is greater than the quadrature-axis synchronous reactance
 - (b) The damper bars help the synchronous motor self-start
 - (c) Short circuit ratio is the ratio of the field current required to produce the rated voltage on open circuit to the rated armature current
 - (d) The V-curve of a synchronous motor represents the variation in the armature current with field excitation, at a given output power
54. Under no load condition, if the applied voltage to an induction motor is reduced from the rated voltage to half the rated value,
- (a) the speed decreases and the stator current increases
 - (b) both the speed and the stator current decrease
 - (c) the speed and the stator current remain practically constant
 - (d) there is negligible change in the speed but the stator current decreases
55. A three-phase cage induction motor is started by direct-on-line (DOL) switching at the rated voltage. If the starting current drawn is 6 times the full load current, and the full load slip is 4%, the ratio of the starting developed torque to the full load torque is approximately equal to
- (a) 0.24 (b) 1.44 (c) 2.40 (d) 6.00
56. In a single phase induction motor driving a fan load, the reason for having a high resistance rotor is to achieve
- (a) low starting torque
 - (b) quick acceleration
 - (c) high efficiency
 - (d) reduced size
57. Determine the correctness or otherwise of the following **Assertion [a]** and the **Reason [r]**.
- Assertion:** Under V/f control of induction motor, the maximum value of the developed torque remains constant over a wide range of speed in the sub-synchronous region.
- Reason:** The magnetic flux is maintained almost constant at the rated value by keeping the ratio V/f constant over the considered speed range.
- (a) Both [a] and [r] are true and [r] is the correct reason for [a]
 - (b) Both [a] and [r] are true but [r] is not the correct reason for [a]
 - (c) Both [a] and [r] are false
 - (d) [a] is true but [r] is false

58. The parameters of a transposed overhead transmission line are given as:
Self reactance $x_s = 0.5\Omega / km$ and Mutual reactance $x_m = 0.1\Omega / km$
The positive sequence reactance x_1 and zero sequence reactance x_0 , respectively, in Ω/km are
(a) 0.3, 0.2 (b) 0.5, 0.2 (c) 0.5, 0.6 (d) 0.3, 0.6
59. At an industrial sub-station with a 4 MW load, a capacitor of 2 MVAR is installed to maintain the load power factor at 0.97 lagging. If the capacitor goes out of service, the load power factor becomes
(a) 0.85 lag (b) 1.00 lag (c) 0.80 lag (d) 0.90 lag
60. The network shown in Fig.Q60 has impedances in p.u. as indicated. The diagonal element Y_{22} of the bus admittance matrix Y_{BUS} of the network is:

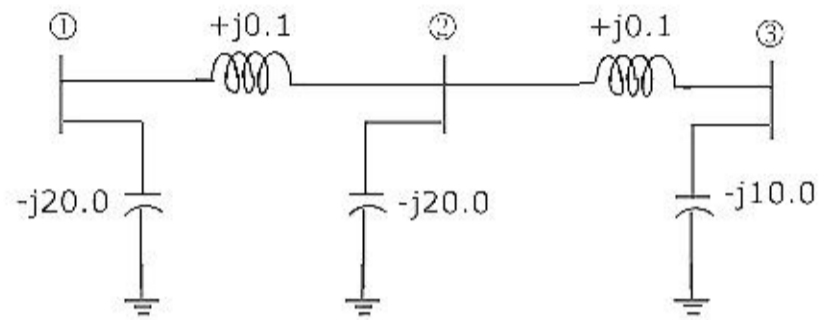

- (a) $-j19.8$ (b) $+j20.0$ (c) $+j0.2$ (d) $-j19.95$
61. A load centre is at an equidistant from the two thermal generating stations G_1 and G_2 as shown in Fig.Q61. The fuel cost characteristics of the generating stations are given by
 $F_1 = a + bP_1 + cP_1^2$ Rs/hour
 $F_2 = a + bP_2 + 2cP_2^2$ Rs/hour
where P_1 and P_2 are the generation in MW of G_1 and G_2 , respectively. For most economic generation to meet 300 MW of load, P_1 and P_2 , respectively, are
(a) 150, 150 (b) 100, 200 (c) 200, 100 (d) 175, 125
62. Two networks are connected in cascade as shown in Fig.Q62. With the usual notations the equivalent A, B, C and D constants are obtained. Given that $C = 0.025\angle 45^\circ$, the value of Z_2 is:

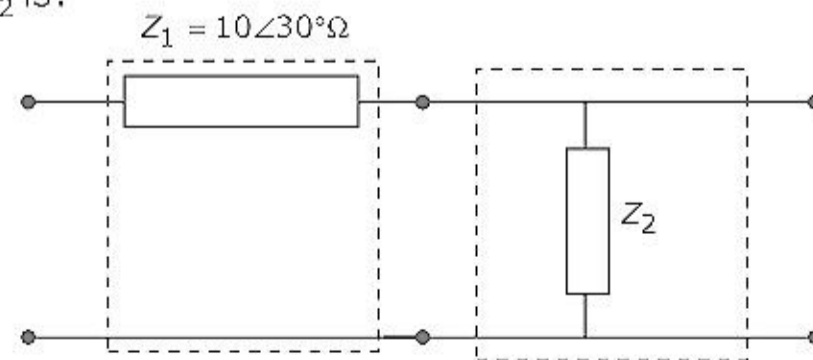

- (a) $10\angle 30^\circ\Omega$
(b) $40\angle -45^\circ\Omega$
(c) 1Ω
(d) 0Ω

63. A generator with constant 1.0 p.u. terminal voltage supplies power through a step-up transformer of 0.12 p.u. reactance and a double-circuit line to an infinite bus as shown in Fig.Q63. The infinite bus voltage is maintained at 1.0 p.u. Neglecting the resistances and susceptances of the system, the steady state stability power limit of the system is 6.25 p.u. If one of the double-circuit is tripped, the resulting steady state stability power limit in p.u. will be

- (a) 12.5 p.u.
 (b) 3.125 p.u.
 (c) 10.0 p.u.
 (d) 5.0 p.u.

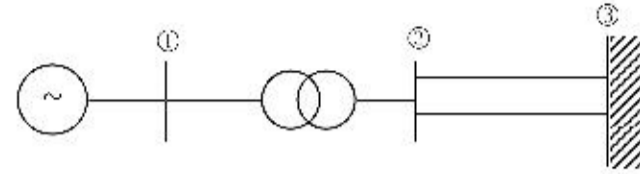

64. The simultaneous application of signals $x(t)$ and $y(t)$ to the horizontal and vertical plates, respectively, of an oscilloscope, produces a vertical figure-of-8 display. If P and Q are constants, and $x(t) = P \sin(4t + 30)$, then $y(t)$ is equal to

- (a) $Q \sin(4t - 30)$ (b) $Q \sin(2t + 15)$ (c) $Q \sin(8t + 60)$ (d) $Q \sin(4t + 30)$

65. A DC ammeter has a resistance of 0.1Ω and its current range is $0 - 100A$. If the range is to be extended to $0 - 500A$, the meter requires the following shunt resistance:

- (a) 0.010Ω (b) 0.011Ω (c) 0.025Ω (d) 1.0Ω

66. The set-up in Fig.Q66 is used to measure resistance R . The ammeter and voltmeter resistances are 0.01Ω and 2000Ω , respectively. Their readings are $2A$ and $180V$, respectively, giving a measured resistance of 90Ω . The percentage error in the measurement is:

- (a) 2.25% (b) 2.35%
 (c) 4.5% (d) 4.71%

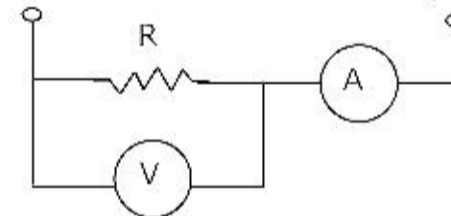

67. A 1000 V DC supply has two 1-core cables as its positive and negative leads; their insulation resistances to earth are $4 M\Omega$ and $6 M\Omega$, respectively, as shown in Fig.Q67. A voltmeter with resistance $50 K\Omega$ is used to measure the insulation of the cable. When connected between the positive core and earth, the voltmeter reads

← 1000V →

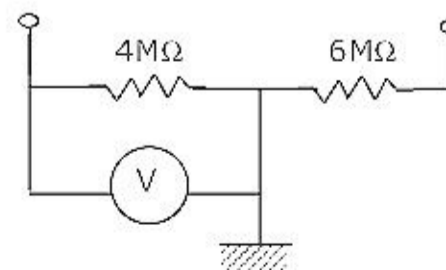

- (a) 8 V (b) 16 V (c) 24 V (d) 40 V

68. Two wattmeters, which are connected to measure the total power on a three-phase system supplying a balanced load, read 10.5 kW and -2.5 kW, respectively. The total power and the power factor, respectively, are
- (a) 13.0 kW, 0.334 (b) 13.0 kW, 0.684
 (c) 8.0 kW, 0.52 (d) 8.0 kW, 0.334

69. The common emitter amplifier shown in Fig.Q69 is biased using a 1 mA ideal current source. The approximate base current value is:

- (a) 0 μ A
 (b) 10 μ A
 (c) 100 μ A
 (d) 1000 μ A

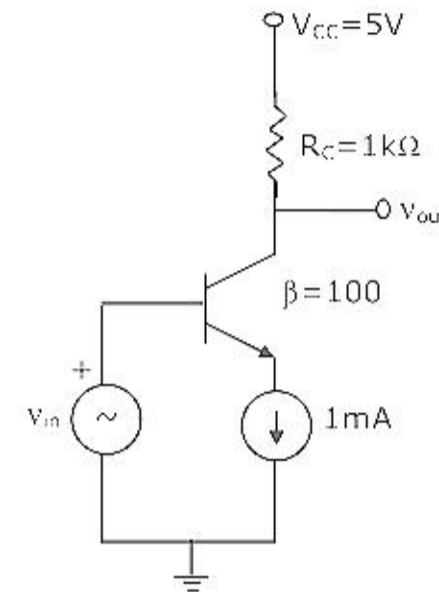

70. Consider the inverting amplifier, using an ideal operational amplifier shown in Fig.Q70. The designer wishes to realize the input resistance seen by the small-signal source to be as large as possible, while keeping the voltage gain between -10 and -25. the upper limit on R_F is 1 M Ω . The value of R_1 should be

- (a) Infinity
 (b) 1 M Ω
 (c) 100 k Ω
 (d) 40 k Ω

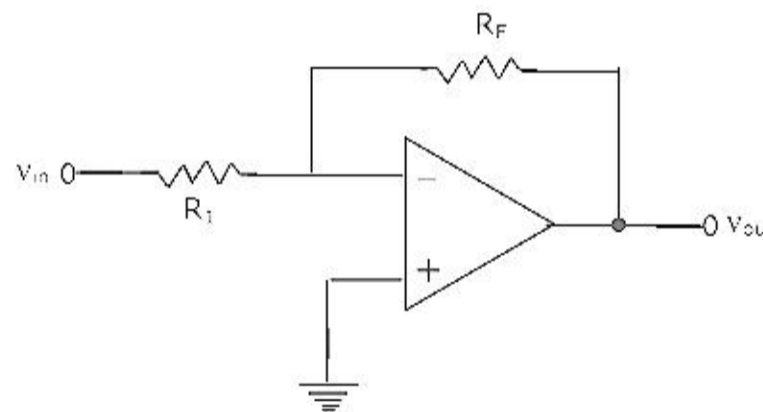

71. The typical frequency response of a two-stage direct coupled voltage amplifier is as shown in

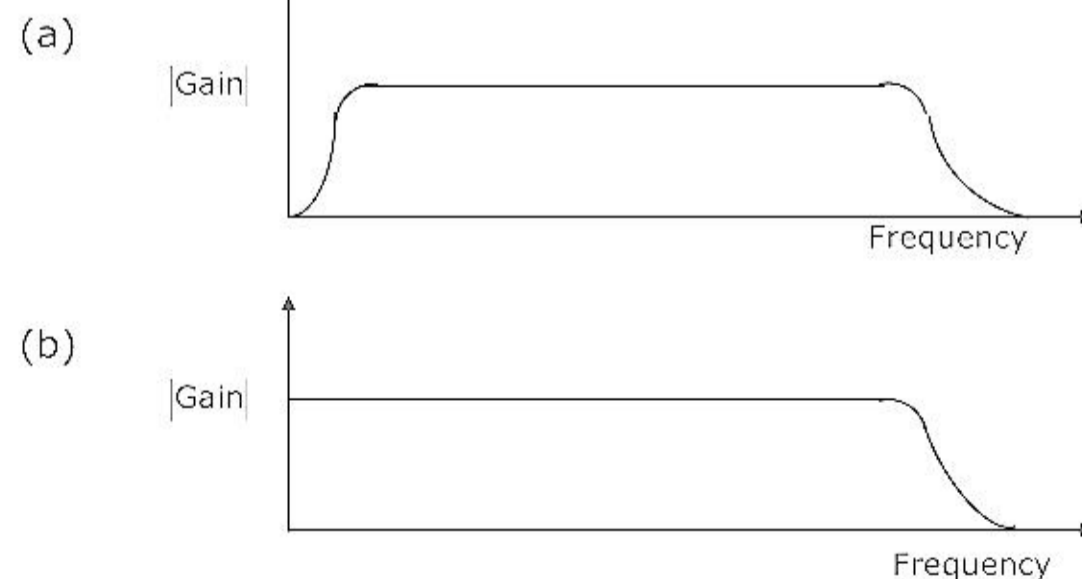

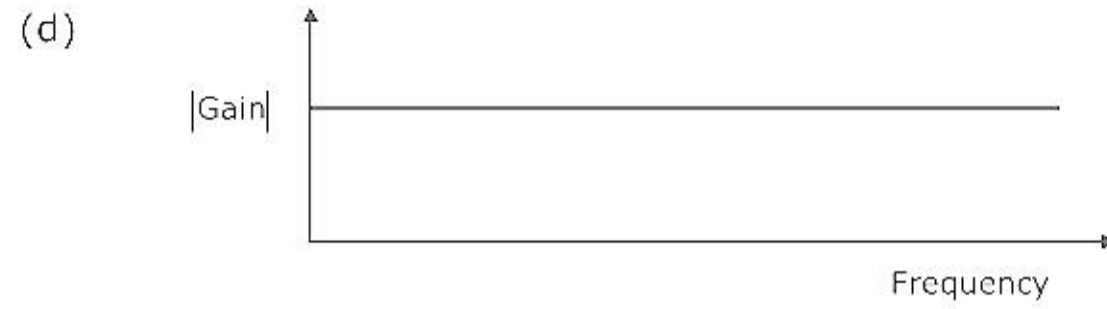
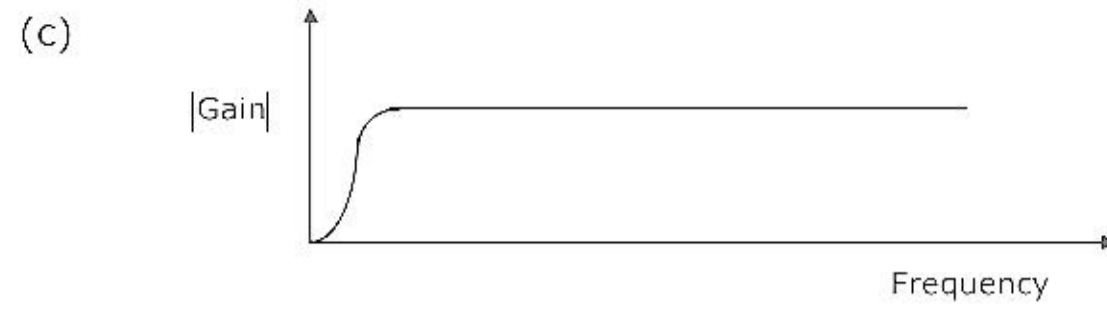

72. In Fig.Q72, if the input is a sinusoidal signal, the output will appear as shown in

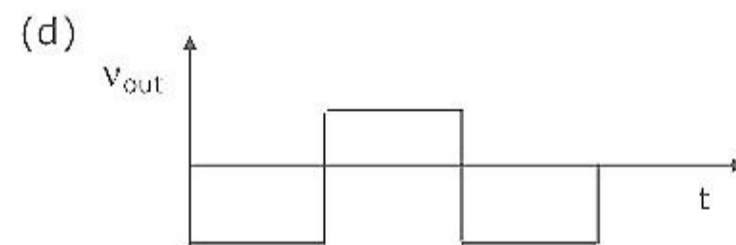
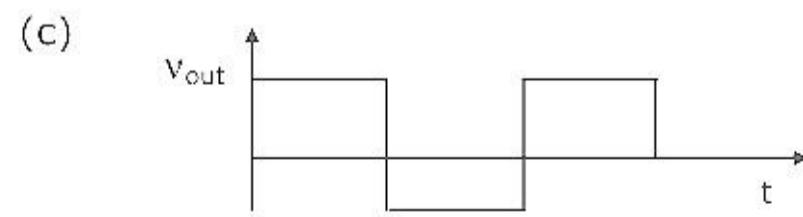
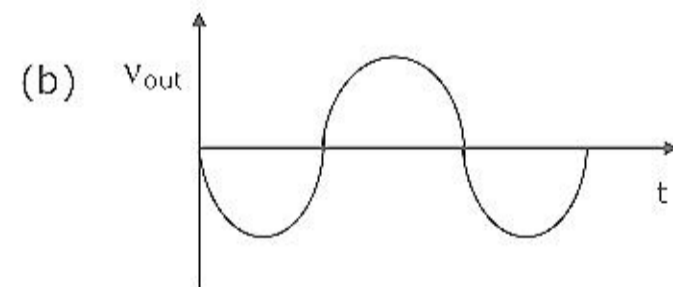
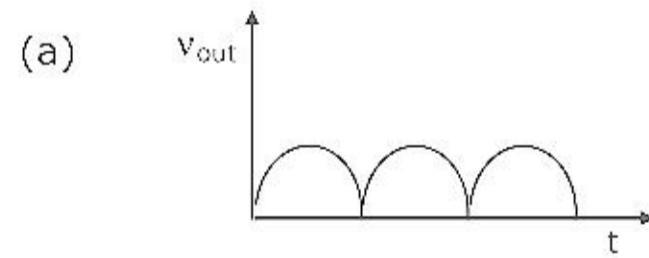
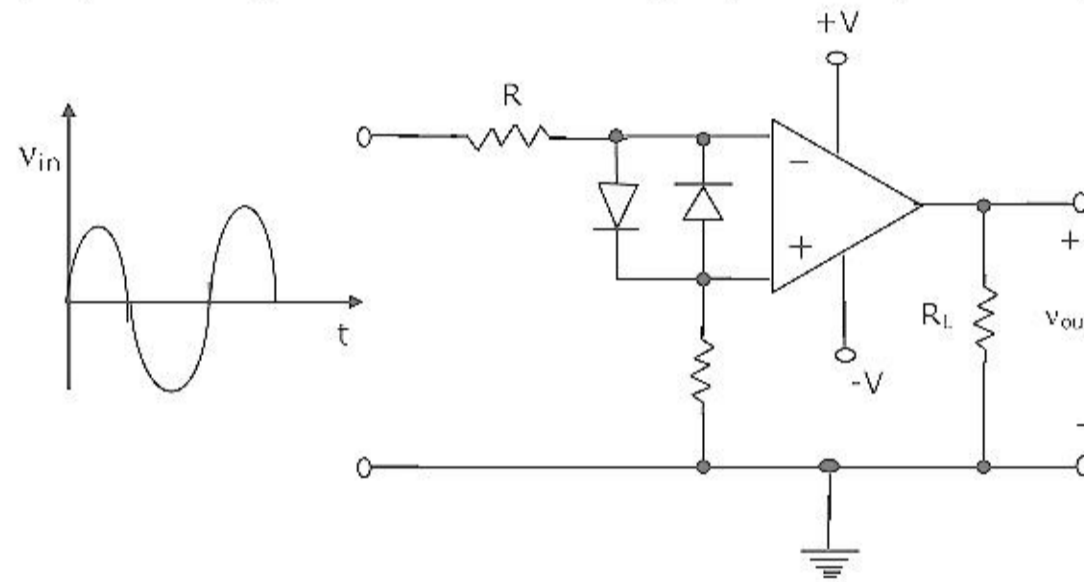

73. Select the circuit, which will produce the given output Q for the input signals X_1 and X_2 given in Fig.Q73.

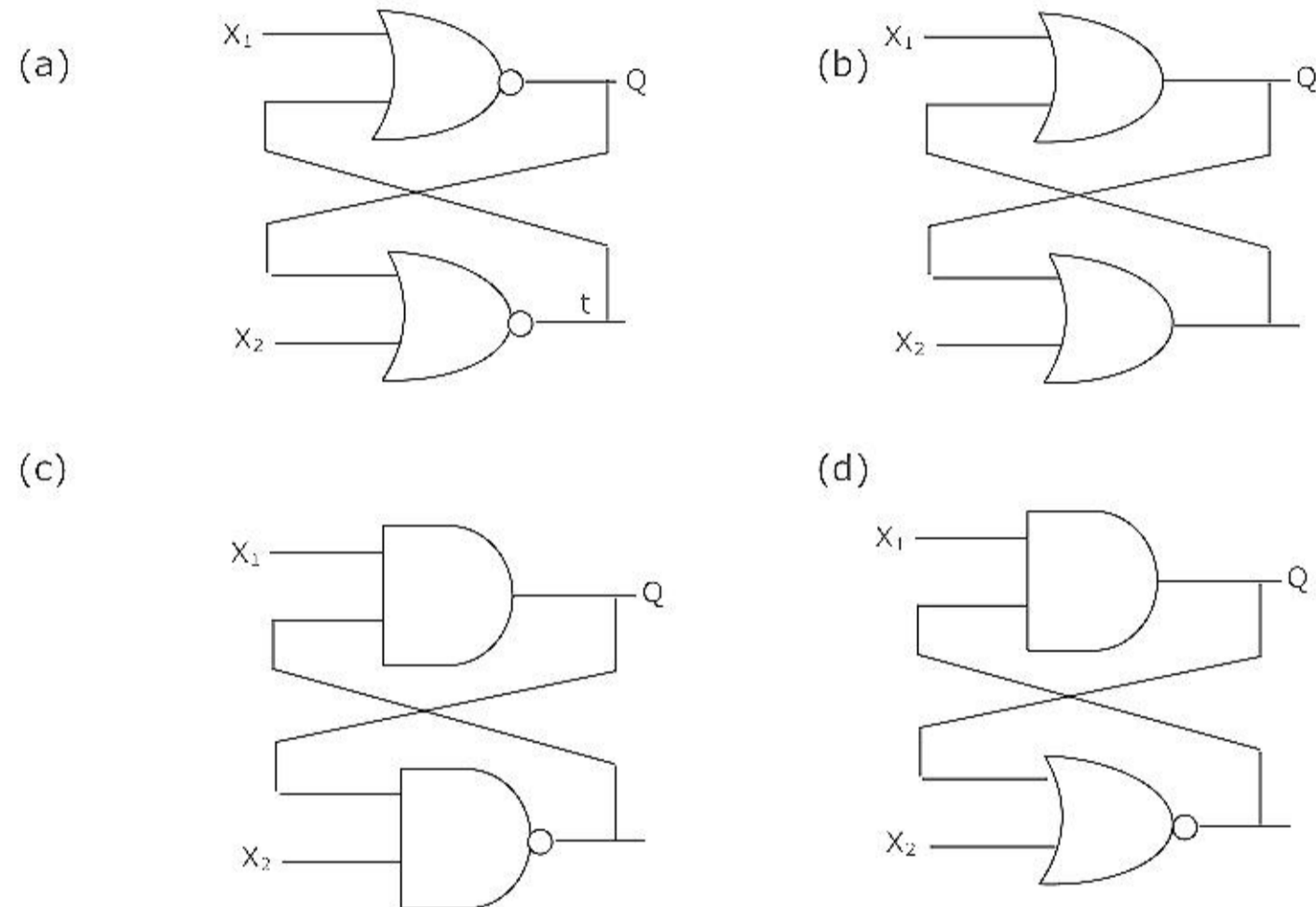
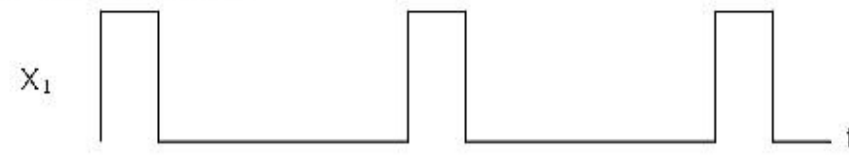

74. If X_1 and X_2 are the inputs to the circuit shown in Fig.Q74, the output Q is:

- (a) $\overline{X_1 + X_2}$
 (b) $\overline{X_1 \cdot X_2}$
 (c) $\overline{X_1} \cdot X_2$
 (d) $X_1 \cdot \overline{X_2}$

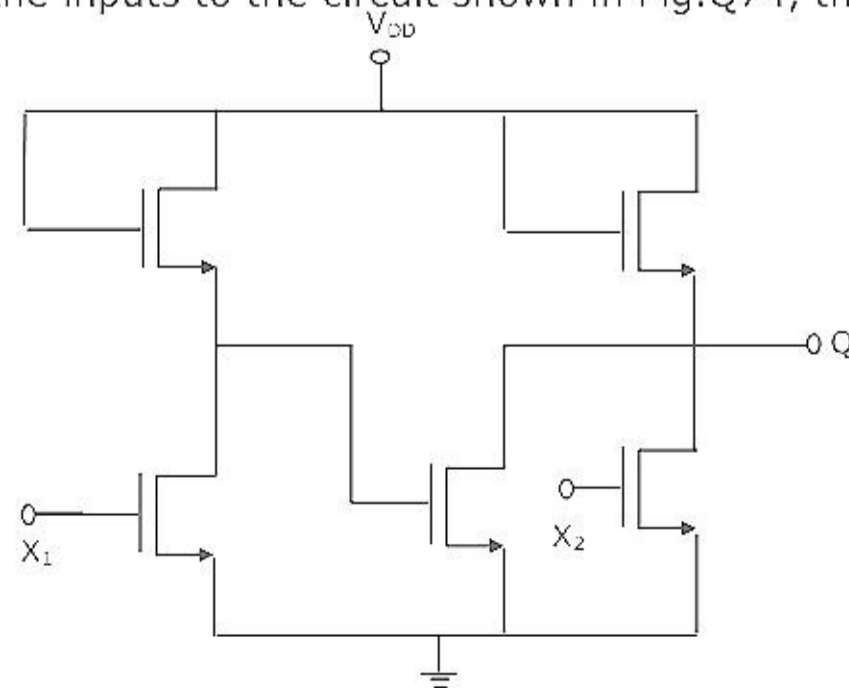

75. In Fig.Q75, as long as $X_1 = 1$ and $X_2 = 1$, the output Q remains

- (a) at 1
- (b) at 0
- (c) at its initial value
- (d) unstable

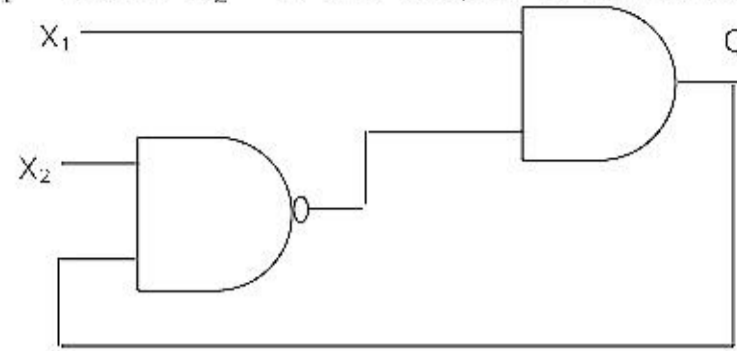

76. Fig.Q76 shows the voltage across a power semiconductor device and the current through the device during a switching transition. Is the transition a turn ON transition or a turn OFF transition? What is the energy lost during the transition?

- (a) Turn ON, $\frac{VI}{2}(t_1 + t_2)$
- (b) Turn OFF, $VI(t_1 + t_2)$
- (c) Turn ON, $VI(t_1 + t_2)$
- (d) Turn OFF, $\frac{VI}{2}(t_1 + t_2)$

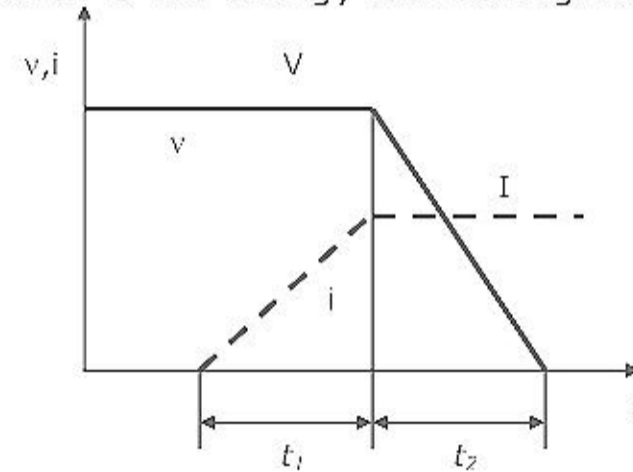

77. An electronic switch S is required to block voltages of either polarity during its OFF state as shown in Fig.Q.77a. This switch is required to conduct in only one direction during its ON state as shown in Fig.Q77b.

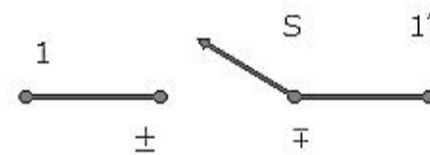

Fig.Q77a

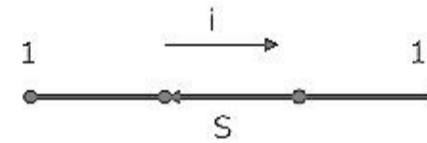
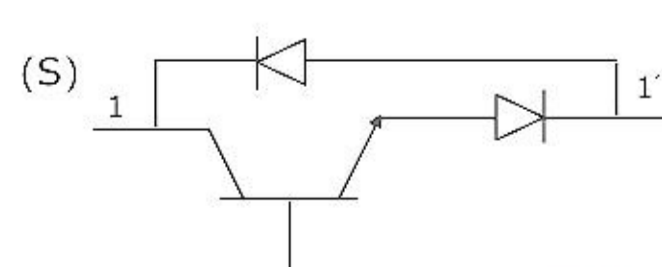
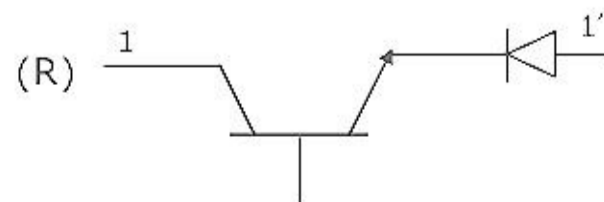
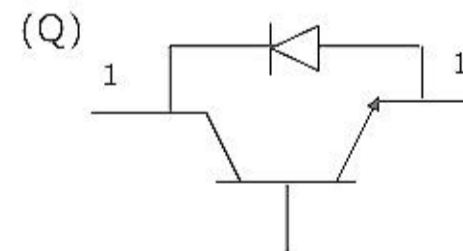
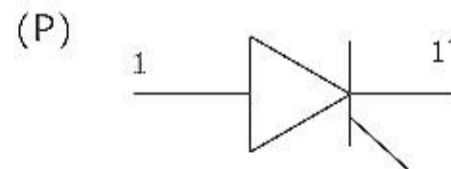

Fig.Q77b

Which of the following are valid realizations of the switch S?



- (a) Only P (b) P and Q (c) P and R (d) R and S

78. Fig.Q78 shows a step-down chopper switched at 1 KHz with a duty ratio $D = 0.5$. The peak-peak ripple in the load current is close to

- (a) 10 A
(b) 0.5 A
(c) 0.125 A
(d) 0.25 A

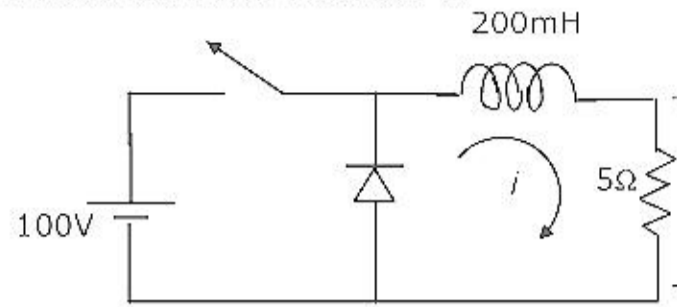

79. An electric motor, developing a starting torque of 15 Nm, starts with a load torque of 7 Nm on its shaft. If the acceleration at start is 2 rad/sec^2 , the moment of inertia of the systems must be (neglecting viscous and Coulomb/friction).

- (a) 0.25 kg m^2 (b) 0.25 Nm^2 (c) 4 kg m^2 (d) 4 Nm^2

80. Consider a phase controlled converter shown in Fig.Q.80. The thyristor is fired at an angle α in every positive half cycle of the input voltage. If the peak value of the instantaneous output voltage equals 230 V, the firing angle α is close to

- (a) 45°
(b) 135°
(c) 90°
(d) 83.6°

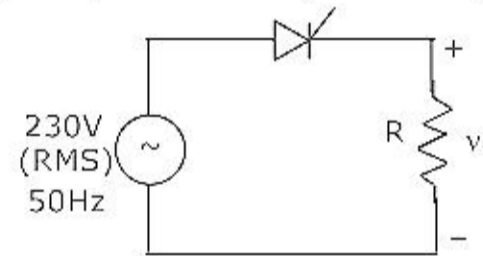

Linked Answer Questions: 81a to Q85b carry two marks each

Statement for Linked Answer Questions 81a & 81b: A coil of inductance 10 H resistance 40Ω is connected as shown in Fig.Q81. After the switch S has been in connection with point 1 for a very long time, it is moved to point 2 at $t = 0$.

81. **(A)** If, at $t = 0^+$, the voltage across the coil is 120V, the value of resistance R is:

- (a) 0Ω
(b) 20Ω
(c) 40Ω
(d) 60Ω

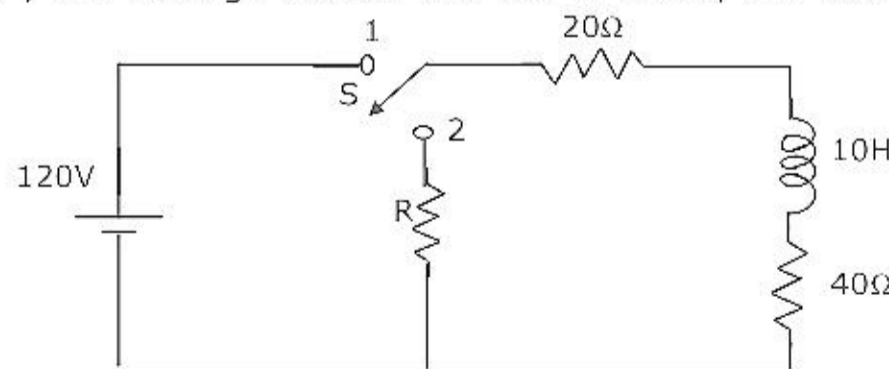

(B) For the value of R obtained in (a), the time taken for 95% of the stored energy dissipated is close to

- (a) 0.10 sec (b) 0.15 sec (c) 0.50 sec (d) 1.0 sec

Statement for Linked Answer Questions 82a & 82b:

A state variable system

$\dot{X}(t) = \begin{bmatrix} 0 & 1 \\ 0 & -3 \end{bmatrix} X(t) + \begin{bmatrix} 1 \\ 0 \end{bmatrix} u(t)$, with the initial condition $X(0) = [-1 \ 3]^T$ and the unit step input $u(t)$ has

82. **(A)** The state transition matrix

(a) $\begin{bmatrix} 1 & \frac{1}{3}(1 - e^{-3t}) \\ 0 & e^{-3t} \end{bmatrix}$

(b) $\begin{bmatrix} 1 & \frac{1}{3}(e^{-t} - e^{-3t}) \\ 0 & e^{-t} \end{bmatrix}$

(c) $\begin{bmatrix} 1 & \frac{1}{3}(e^{-t} - e^{-3t}) \\ 0 & e^{-3t} \end{bmatrix}$

(d) $\begin{bmatrix} 1 & (1 - e^{-t}) \\ 0 & e^{-t} \end{bmatrix}$

(B) and the state transition equation

(a) $X(t) = \begin{bmatrix} t - e^{-t} \\ e^{-t} \end{bmatrix}$

(b) $X(t) = \begin{bmatrix} t - e^{-t} \\ 3e^{-3t} \end{bmatrix}$

(c) $X(t) = \begin{bmatrix} t - e^{-3t} \\ 3e^{-3t} \end{bmatrix}$

(d) $X(t) = \begin{bmatrix} t - e^{-3t} \\ e^{-t} \end{bmatrix}$

Statement for Linked Answer Questions 83a & 83b: A 1000 kVA, 6.6 kV, 3-phase star connected cylindrical pole synchronous generator has a synchronous reactance of 20 Ω . Neglect the armature resistance and consider operation at full load and unity power factor.

83. **(A)** The induced emf (line-to-line) is close to

- (a) 5.5 kV (b) 7.2 kV (c) 9.6 kV (d) 12.5 kV

(B) The power (or torque) angle is close to

- (a) 13.9° (b) 18.3° (c) 24.6° (d) 33.0°

Statement for Linked Answer Questions 84a & 84b: At a 220 kV substation of a power system, it is given that the three-phase fault level is 4000 MVA and single-line to ground fault level is 5000 MVA. Neglecting the resistance and the shunt susceptances of the system,

84. **(A)** the positive sequence driving point reactance at the bus is:

- (a) 2.5 Ω (b) 4.033 Ω (c) 5.5 Ω (d) 12.1 Ω

(B) and the zero sequence driving point reactance at the bus is:

- (a) 2.2Ω (b) 4.84Ω (c) 18.18Ω (d) 22.72Ω

Statement for Linked Answer Questions 85a & 85b: Assume that the threshold voltage of the N-channel MOSFET shown in Fig. Q85 is $+0.75V$. The output characteristics of the MOSFET are also shown.

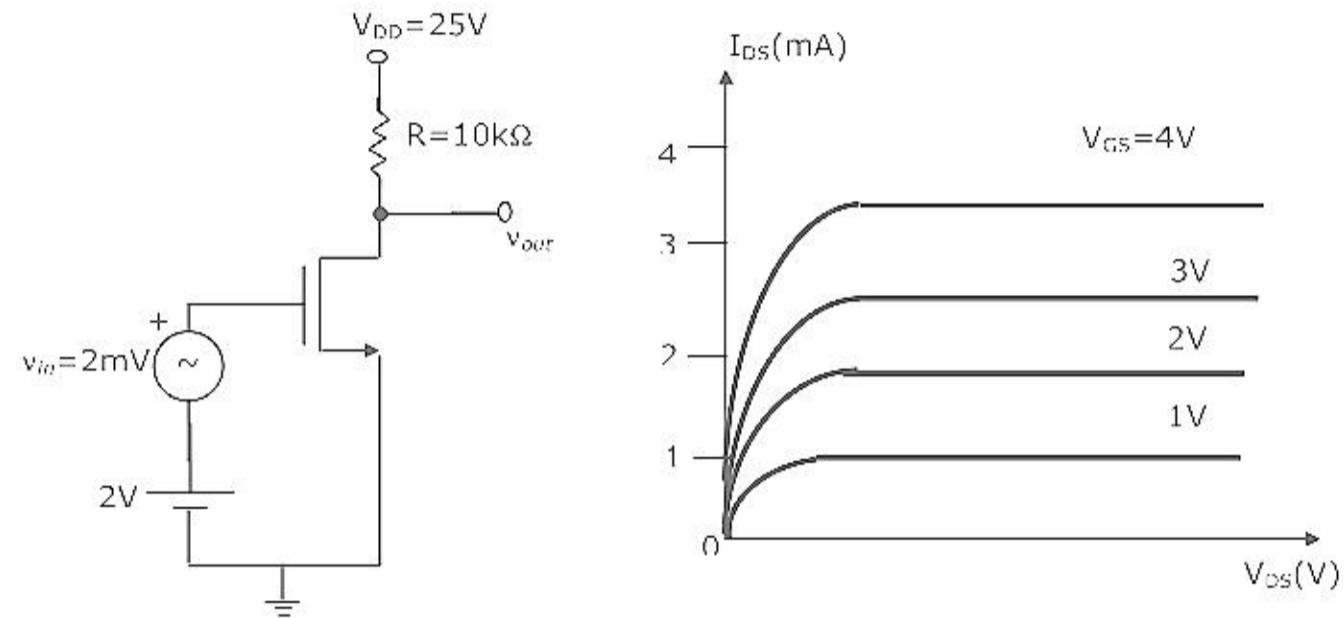

85. (A) The transconductance of the MOSFET is:
(a) 0.75 mS (b) 1 mS (c) 2 mS (d) 10 mS
- (B) The voltage gain of the amplifier is:
(a) $+5$ (b) -7.5 (c) $+10$ (d) -10