

Andhra Pradesh State Council of Higher Education

Question Paper Name :	Electronics Communication Engineering EC 29th Sep 2020 Shift 1
Subject Name :	Electronics & Communication Engineering (EC)
Creation Date :	2020-09-29 12:49:23
Duration :	120
Total Marks :	120
Display Marks:	No
Share Answer Key With Delivery Engine :	Yes
Actual Answer Key :	Yes

Electronics & Communication Engineering (EC)

Group Number :	1
Group Id :	29996534
Group Maximum Duration :	0
Group Minimum Duration :	120
Show Attended Group? :	No
Edit Attended Group? :	No
Break time :	0
Group Marks :	120
Is this Group for Examiner? :	No
Revisit allowed for group Instructions? :	Yes
Maximum Instruction Time :	0
Minimum Instruction Time :	0

Electronics & Communication Engineering (EC)

Section Id :	29996534
Section Number :	1
Mandatory or Optional :	Mandatory
Number of Questions :	120
Section Marks :	120
Display Number Panel :	Yes
Group All Questions :	Yes
Mark As Answered Required? :	Yes
Sub-Section Number :	1
Sub-Section Id :	29996534
Question Shuffling Allowed :	Yes

Question Number : 1 Question Id : 2999653961 Question Type : MCQ Display Question Number : Yes Is Question Mandatory : No Single Line Question Option : No Option Orientation : Vertical

What is the value of a for which the equations

$$x + ay + z = 3$$

$$x + 2y + 2z = 6$$

$$x + 5y + 3z = 9$$

are consistent?

Options :

1. 1

2. -4

3. 2

4. -2

Question Number : 2 Question Id : 2999653962 Question Type : MCQ Display Question Number : Yes Is Question Mandatory : No Single Line Question Option : No Option Orientation : Vertical

The function $(x) = 6x^{1/3} - 10$ defined on the interval $[2, 3]$ attains its maximum value at _____.

Options :

1. $x = 0$

2. $x = -1$

3. $x = 2$

4. $x = 3$

Question Number : 3 Question Id : 2999653963 Question Type : MCQ Display Question Number : Yes Is Question Mandatory : No Single Line Question Option : No Option Orientation : Vertical

The value of the line integral $\int_C \vec{F} \cdot d\vec{r}$, where $\vec{F} = (x + y + z)\hat{i} + (2x - z)\hat{j} + (y + z)\hat{k}$ and C is the boundary of the triangle with vertices $(1, 0, 0)$, $(0, 2, 0)$, $(0, 0, 4)$ is _____.

Options :

1. 0

2. 1

3. 5

4. 3

Question Number : 4 Question Id : 2999653964 Question Type : MCQ Display Question Number : Yes Is Question Mandatory : No Single Line Question Option : No Option Orientation : Vertical

Which of the following is the solution of the partial differential equation $\frac{\partial z}{\partial x} \frac{\partial z}{\partial y} = 1$

where (a, b) are arbitrary constants?

Options :

1. $z = a(x + y)$

1.

2. $z = ax + \frac{y}{a} + b$

2.

3. $z = (x + a)(y + b)$

3.

4. $z = \frac{x}{y}$

4.

Question Number : 5 Question Id : 2999653965 Question Type : MCQ Display Question Number : Yes Is Question Mandatory : No Single Line Question Option : No Option Orientation : Vertical

The inverse Laplace transform of

$$F(s) = \frac{5}{(s+2)^3} \quad \text{is } \underline{\hspace{2cm}}.$$

Options :

1. $\frac{5}{2} t e^{-2t}$

1.

2. $\frac{5}{2} t^2 e^{2t}$

2.

3. $\frac{5}{2}t^2 e^{-2t}$

4. $\frac{5}{2}te^{2t}$

Question Number : 6 Question Id : 2999653966 Question Type : MCQ Display Question Number : Yes Is Question Mandatory : No Single Line Question Option : No Option Orientation : Vertical

For the function $f(z) = \frac{\sin z}{z^3}$, the point $z = 0$ is _____.

Options :

1. a pole of order 3

2. a pole of order 2

3. a pole of order 1

4. not a singularity

Question Number : 7 Question Id : 2999653967 Question Type : MCQ Display Question Number : Yes Is Question Mandatory : No Single Line Question Option : No Option Orientation : Vertical

For a Normal distribution, which of the following statements is true?

Options :

1. Mean > Median > Mode

2. Mean < Median < Mode

3. Mean = Median = Mode

4. Mean < Median > Mode

Question Number : 8 Question Id : 2999653968 Question Type : MCQ Display Question Number : Yes Is Question Mandatory : No Single Line Question Option : No Option Orientation : Vertical

If A and B are independent events and $P(A)=1$, $P(B)=\frac{1}{2}$ then $P(A/B)$ and

$P(B/A)$ are _____.

Options :

1. $\frac{1}{2}$ and $\frac{1}{4}$

2. $\frac{1}{2}$ and 1

3. $\frac{1}{4}$ and $\frac{1}{2}$

4. 1 and $\frac{1}{2}$

Question Number : 9 Question Id : 2999653969 Question Type : MCQ Display Question Number : Yes Is Question Mandatory : No Single Line Question Option : No Option Orientation : Vertical

The order of convergence of the Secant method is _____.

Options :

1. 1.82

2. 2

3. 1.62

4. 1.72

Question Number : 10 Question Id : 2999653970 Question Type : MCQ Display Question Number : Yes Is Question Mandatory : No Single Line Question Option : No Option Orientation : Vertical

Find the numerical value of $y(0.2)$ by solving the differential equation

$$\frac{dy}{dx} = 1 + y^2, \quad y(0) = 0, \quad h = 0.2$$

using the 2nd order Runge-Kutta method.

Options :

1. 0.203
2. 0.204
3. 0.202
4. 0.205

Question Number : 11 Question Id : 2999653971 Question Type : MCQ Display Question Number : Yes Is Question Mandatory : No Single Line Question Option : No Option Orientation : Vertical

Two 2H inductance coils are connected in series and are also magnetically coupled to each other the coefficient of coupling being 0.1. The total inductance of the combination can be _____.

Options :

1. 0.4 H
2. 3.2 H
3. 4.0 H
4. 4.4 H

Question Number : 12 Question Id : 2999653972 Question Type : MCQ Display Question Number : Yes Is Question Mandatory : No Single Line Question Option : No Option Orientation : Vertical

A load, $Z_L = R_L + jX_L$ is to be matched using an ideal transformer, to a generator of internal impedance, $Z_s = R_s + jX_s$. The turn's ratio of the transformer required is _____.

Options :

1. $\sqrt{|Z_L / Z_s|}$
2. $\sqrt{|R_L / R_s|}$
3. $\sqrt{|R_L / Z_s|}$

4. $\sqrt{|Z_L / R_s|}$

Question Number : 13 Question Id : 2999653973 Question Type : MCQ Display Question Number : Yes Is Question Mandatory : No Single Line Question Option : No Option Orientation : Vertical

The Laplace Transform of a periodic function with period T is equal to _____ times the Laplace transform of the first cycle.

Options :

1. $(1 - e^{sT})$

2. $1 / (1 - e^{sT})$

3. $2e^{Ts} / (1 - e^{Ts})$

4. $2e^{Ts}(1 - e^{Ts})$

Question Number : 14 Question Id : 2999653974 Question Type : MCQ Display Question Number : Yes Is Question Mandatory : No Single Line Question Option : No Option Orientation : Vertical

The dynamic impedance of parallel circuit undergoing resonance is equal to _____.

Options :

1. $Z_0 = L / CR_L$

2. $Z_0 = CR_L$

3. $Z_0 = L$

4. $Z_0 = CR_L.L$

Question Number : 15 Question Id : 2999653975 Question Type : MCQ Display Question Number : Yes Is Question Mandatory : No Single Line Question Option : No Option Orientation : Vertical

The elements in the incidence matrix are _____.

Options :

1. 0

2. 1

3. 1, 1

4. 0, -1 and 1

Question Number : 16 Question Id : 2999653976 Question Type : MCQ Display Question Number : Yes Is Question Mandatory : No Single Line Question Option : No Option Orientation : Vertical

Three equal resistances of 5Ω are connected in delta. What is the resistance in one of the arms of the equivalent star circuit?

Options :

1. 5Ω

2. 1.33Ω

3. 1.5Ω

4. 13.3Ω

Question Number : 17 Question Id : 2999653977 Question Type : MCQ Display Question Number : Yes Is Question Mandatory : No Single Line Question Option : No Option Orientation : Vertical

The cut-set schedule gives the relation between _____.

Options :

1. Branch currents and link currents

2. Branch voltages and tree branch voltages

3. Branch voltages and link voltages

4. branch currents and tree currents

Question Number : 18 Question Id : 2999653978 Question Type : MCQ Display Question Number : Yes Is Question Mandatory : No Single Line Question Option : No Option Orientation : Vertical

The transient current in loss free current LC circuit when excited from an AC source is an _____ sine wave.

Options :

1. Un-damped
2. over damped
3. under damped
4. critically damped

Question Number : 19 Question Id : 2999653979 Question Type : MCQ Display Question Number : Yes Is Question Mandatory : No Single Line Question Option : No Option Orientation : Vertical

If the unit step response of a network is $(1 - e^{-\alpha t})$, then its unit impulse response is

_____.

Options :

1. $\alpha e^{-\alpha t}$
2. $\alpha^{-1} e^{-\alpha t}$
3. $(1 - \alpha^{-1}) e^{-\alpha t}$
4. $(1 - \alpha) e^{-\alpha t}$

Question Number : 20 Question Id : 2999653980 Question Type : MCQ Display Question Number : Yes Is Question Mandatory : No Single Line Question Option : No Option Orientation : Vertical

The inverse Laplace transform of $2 \log \frac{(S+2)}{S}$ is _____.

Options :

1. $\frac{2 - e^{-2t}}{t}$
2. $\frac{e^{-2t}}{t}$
3. $\frac{2}{t}$

$$\frac{2 + e^{-2t}}{t}$$

4.

Question Number : 21 Question Id : 2999653981 Question Type : MCQ Display Question Number : Yes Is Question Mandatory : No Single Line Question Option : No Option Orientation : Vertical

The condition $AD - BC = 1$ for a two port network implies that the network is

a _____.

Options :

1. reciprocal network
2. lumped element network
3. lossless network
4. unilateral element network

Question Number : 22 Question Id : 2999653982 Question Type : MCQ Display Question Number : Yes Is Question Mandatory : No Single Line Question Option : No Option Orientation : Vertical

The currents i_1 and i_2 for the following network are _____.

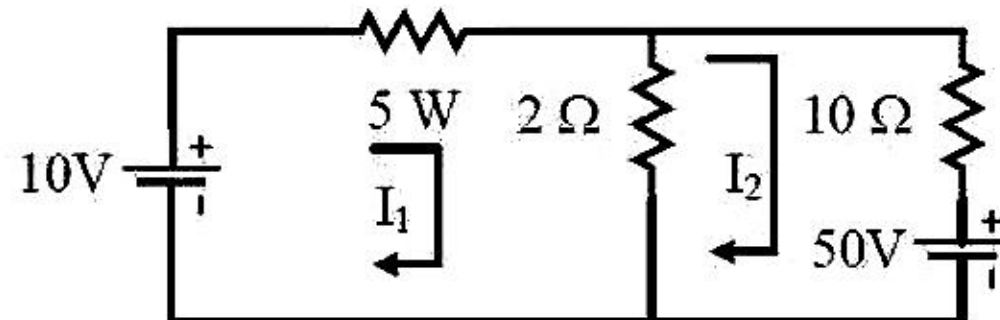

Options :

1. $-0.25 \text{ A}, -4.125 \text{ A}$
2. $0.25 \text{ A}, 4.125 \text{ A}$
3. $0.25 \text{ A}, -4.125 \text{ A}$
4. $-0.25 \text{ A}, 4.125 \text{ A}$

Question Number : 23 Question Id : 2999653983 Question Type : MCQ Display Question Number : Yes Is Question Mandatory : No Single Line Question Option : No Option Orientation : Vertical

Photo diodes operate in _____.

Options :

1. Negative bias
2. Forward bias
3. Both negative and forward bias
4. Zero bias conditions

Question Number : 24 Question Id : 2999653984 Question Type : MCQ Display Question Number : Yes Is Question Mandatory : No Single Line Question Option : No Option Orientation : Vertical

The transconductance g_m of MOSFET is _____.

Options :

1. $\left. \frac{\Delta I_D}{\Delta V_{GS}} \right|_{V_{DS} = \text{constant}}$

2. $\left. \frac{\Delta I_D}{\Delta V_{DS}} \right|_{V_{GS} = \text{constant}}$

3. $\left. \frac{\Delta V_{DS}}{\Delta I_D} \right|_{V_{GS} = \text{constant}}$

4. $\left. \frac{\Delta V_{GS}}{\Delta I_D} \right|_{V_{DS} = \text{constant}}$

Question Number : 25 Question Id : 2999653985 Question Type : MCQ Display Question Number : Yes Is Question Mandatory : No Single Line Question Option : No Option Orientation : Vertical

Drift current in semiconductors depends upon _____.

Options :

1. only the electric field
2. only the carrier concentration gradient
3. Both the electric field and carrier concentration
4. Neither the electric field nor the carrier concentration

Question Number : 26 Question Id : 2999653986 Question Type : MCQ Display Question Number : Yes Is Question Mandatory : No Single Line Question Option : No Option Orientation : Vertical

A zener diode, when used in voltage stabilization circuits, is biased in _____.

Options :

1. Reverse bias region below the breakdown voltage
2. Reverse breakdown region
3. Forward bias region
4. Forward bias constant current mode

Question Number : 27 Question Id : 2999653987 Question Type : MCQ Display Question Number : Yes Is Question Mandatory : No Single Line Question Option : No Option Orientation : Vertical

In CMOS fabrication, the photo resist layer is exposed to _____.

Options :

1. Visible light
2. Ultraviolet light
3. Infrared light
4. Fluorescent

Question Number : 28 Question Id : 2999653988 Question Type : MCQ Display Question Number : Yes Is Question Mandatory : No Single Line Question Option : No Option Orientation : Vertical

In a MOSFET operating in the saturation region, the channel length modulation effect causes _____.

Options :

1. an increase in the gate-source capacitance
2. a decrease in the Trans conductance
3. a decrease in the unity-gain cut-off frequency
4. a decrease in the output resistance

Question Number : 29 Question Id : 2999653989 Question Type : MCQ Display Question Number : Yes Is Question Mandatory : No Single Line Question Option : No Option Orientation : Vertical

A Silicon p-n junction is forward biased with a constant current at room temperature, when the temperature is increased by 10°C , the forward bias voltage across the PN junction _____.

Options :

1. Increases by 60 mV
2. Decreases by 60 mV
3. Increases by 25 mV
4. Decreases by 25 mV

Question Number : 30 Question Id : 2999653990 Question Type : MCQ Display Question Number : Yes Is Question Mandatory : No Single Line Question Option : No Option Orientation : Vertical

The early effect in a bipolar junction transistor is caused by _____.

Options :

1. Fast turn-on
2. Fast turn-off
3. Large collector-base reverse bias

4. large emitter-base forward bias

Question Number : 31 Question Id : 2999653991 Question Type : MCQ Display Question Number : Yes Is Question Mandatory : No Single Line Question Option : No Option Orientation : Vertical

The gate delay of an NMOS inverter is dominated by charge time rather discharge time because _____.

Options :

1. The driver transistor has larger threshold voltage than the load transistor
2. The driver transistor has larger leakage currents compared to the load transistor
3. The load transistor has a smaller W/L ratio compared to the driver transistor
4. The load transistor has a larger W/L ratio compared to the driver transistor

Question Number : 32 Question Id : 2999653992 Question Type : MCQ Display Question Number : Yes Is Question Mandatory : No Single Line Question Option : No Option Orientation : Vertical

The below circuit shown in figure represents a _____.

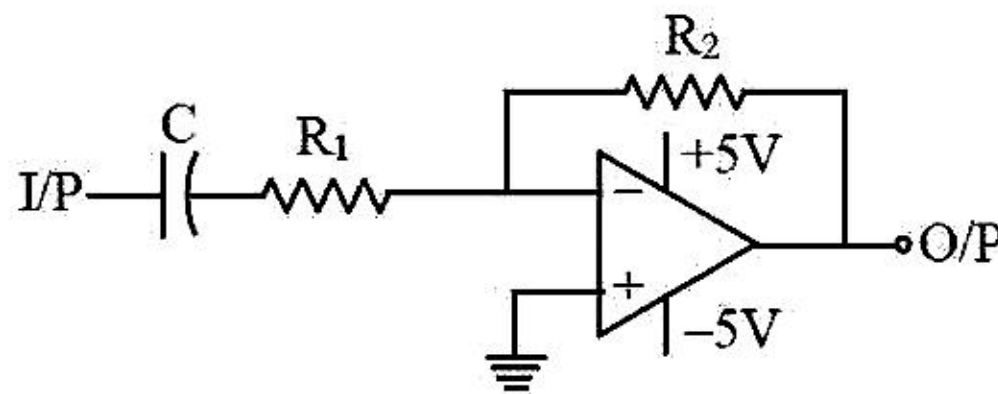

Options :

1. Low pass filter with $f_{3dB} = \frac{1}{(R_1 + R_2)C}$ rad/sec
2. Low pass filter with $f_{3dB} = \frac{1}{R_1 C}$ rad/sec
3. High pass filter with $f_{3dB} = \frac{1}{R_1 C}$ rad/sec

High pass filter with $f_{3dB} = \frac{1}{(R_1 + R_2)C}$ rad/sec

4.

Question Number : 33 Question Id : 2999653993 Question Type : MCQ Display Question Number : Yes Is Question Mandatory : No Single Line Question Option : No Option Orientation : Vertical

The drain current of a MOSFET in saturation is given by $I_D = K (V_{G_S} - V_T)^2$, where

K is a constant. The magnitude of the trans-conductance g_m is _____.

Options :

1. $(V_{G_S} - V_T)^2 / V_{D_S}$

2. $2K(V_{G_S} - V_T)$

3. $I_D / V_{G_S} - V_{D_S}$

4. $(V_{G_S} - V_T)^2 / V_{G_S}$

Question Number : 34 Question Id : 2999653994 Question Type : MCQ Display Question Number : Yes Is Question Mandatory : No Single Line Question Option : No Option Orientation : Vertical

A green color LED emits light with a wavelength 5490 Å unit. Find the energy gap of material in eV.

Options :

1. 6.54 eV

2. 3.67 eV

3. 5.29 eV

4. 2.26 eV

Question Number : 35 Question Id : 2999653995 Question Type : MCQ Display Question Number : Yes Is Question Mandatory : No Single Line Question Option : No Option Orientation : Vertical

Lithography is _____.

Options :

1. pattern to a layer on the chip
2. oxidation layer on the chip
3. used to produce the chip
4. developing metal layer on the chip

Question Number : 36 Question Id : 2999653996 Question Type : MCQ Display Question Number : Yes Is Question Mandatory : No Single Line Question Option : No Option Orientation : Vertical

In which of these is reverse recovery time nearly zero?

Options :

1. Zener Diode
2. Tunnel diode
3. Schottky diode
4. PIN diode

Question Number : 37 Question Id : 2999653997 Question Type : MCQ Display Question Number : Yes Is Question Mandatory : No Single Line Question Option : No Option Orientation : Vertical

The relation between α and β of a transistor is _____.

Options :

1. $\alpha = \frac{\beta + 1}{\beta}$
2. $\alpha = \frac{\beta}{\beta + 1}$
3. $\alpha = \frac{\beta}{\beta - 1}$

4.
$$\alpha = \frac{\beta - 1}{\beta}$$

Question Number : 38 Question Id : 2999653998 Question Type : MCQ Display Question Number : Yes Is Question Mandatory : No Single Line Question Option : No Option Orientation : Vertical

In class-C power amplifier output current flows for _____.

Options :

1. Half cycle

2. Full cycle

3. 3/4 cycle

4. Less than half cycle of input

Question Number : 39 Question Id : 2999653999 Question Type : MCQ Display Question Number : Yes Is Question Mandatory : No Single Line Question Option : No Option Orientation : Vertical

The circuit shown in figure represents _____.

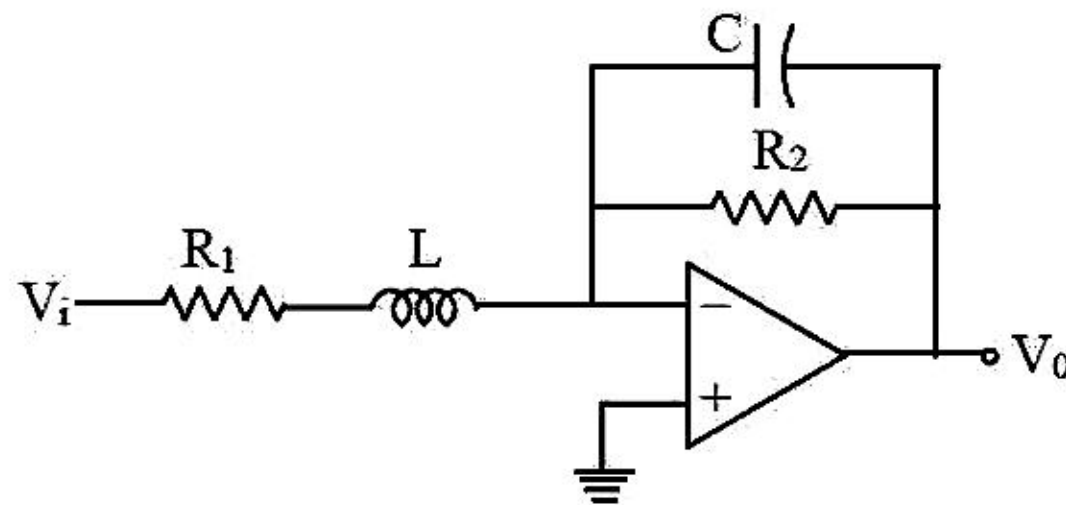

Options :

1. High pass filter

2. Low pass filter

3. Band pass filter

4. Band reject filter

Question Number : 40 Question Id : 2999654000 Question Type : MCQ Display Question Number : Yes Is Question Mandatory : No Single Line Question Option : No Option Orientation : Vertical

Sustained oscillations are produced when the magnitude of loop gain is _____.

Options :

1. 1
2. 0
3. 2
4. ∞

Question Number : 41 Question Id : 2999654001 Question Type : MCQ Display Question Number : Yes Is Question Mandatory : No Single Line Question Option : No Option Orientation : Vertical

In a multistage RC-Coupled amplifier the coupling capacitor _____.

Options :

1. limits the low frequency response
2. limits the high frequency response
3. does not effect the frequency response
4. blocks the DC components without effecting the frequency response

Question Number : 42 Question Id : 2999654002 Question Type : MCQ Display Question Number : Yes Is Question Mandatory : No Single Line Question Option : No Option Orientation : Vertical

Which of the following circuits is useful for transmitting a portion of the given waveform?

Options :

1. Clipping circuits
2. Clamping circuits
3. Linear wave shaping circuits
4. Amplifying circuits

Question Number : 43 Question Id : 2999654003 Question Type : MCQ Display Question Number : Yes Is Question Mandatory : No Single Line Question Option : No Option Orientation : Vertical

A change in the value of the Emitter resistance (R_e) in a difference amplifier _____.

Options :

1. affects the difference mode gain A_d
2. affects the common mode gain A_c
3. affects both A_d and A_c
4. does not affect either A_d or A_c

Question Number : 44 Question Id : 2999654004 Question Type : MCQ Display Question Number : Yes Is Question Mandatory : No Single Line Question Option : No Option Orientation : Vertical

If the differential voltage gain and the common mode voltage gain of a differential amplifier are 48 dB and 2 dB respectively, then its common mode rejection ratio is _____.

Options :

1. 23 dB
2. 25 dB
3. 46 dB
4. 50 dB

Question Number : 45 Question Id : 2999654005 Question Type : MCQ Display Question Number : Yes Is Question Mandatory : No Single Line Question Option : No Option Orientation : Vertical

In a symmetrical free running multivibrator the period of oscillation is given by _____.

Options :

1. $0.69 RC$

2. 1.38 RC
3. 1.1 RC
4. ln RC

Question Number : 46 Question Id : 2999654006 Question Type : MCQ Display Question Number : Yes Is Question Mandatory : No Single Line Question Option : No Option Orientation : Vertical

To obtain very high input and output impedances in a feedback amplifier the mostly used feedback is _____.

Options :

1. voltage – series
2. current – series
3. voltage shunt
4. current – shunt

Question Number : 47 Question Id : 2999654007 Question Type : MCQ Display Question Number : Yes Is Question Mandatory : No Single Line Question Option : No Option Orientation : Vertical

The gain of the first order low pass filter _____.

Options :

1. Increases at the rate 20 dB/decade
2. Increases at the rate 40 dB/decade
3. Decreases at the rate 20 dB/decade
4. Decreases at the rate 40 dB/decade

Question Number : 48 Question Id : 2999654008 Question Type : MCQ Display Question Number : Yes Is Question Mandatory : No Single Line Question Option : No Option Orientation : Vertical

An amplifier has an open loop gain of 1000 ± 10 . Negative feedback is provided such that the gain variation remains within 0.1%. What is amount of feedback?

Options :

1. $1/10$
2. $1/9$
3. $9/100$
4. $9/1000$

Question Number : 49 Question Id : 2999654009 Question Type : MCQ Display Question Number : Yes Is Question Mandatory : No Single Line Question Option : No Option Orientation : Vertical

The two stages of a cascade amplifier have individual upper cut off frequency $f_1 = 5$ MHz and $f_2 = 3.33$ MHz. What is the best approximation for the upper cut off frequency of the cascade combination?

Options :

1. 4.16 MHz
2. 3.33 MHz
3. 2.5 MHz
4. 5.00 MHz

Question Number : 50 Question Id : 2999654010 Question Type : MCQ Display Question Number : Yes Is Question Mandatory : No Single Line Question Option : No Option Orientation : Vertical

An ideal op-amp is an ideal_____.

Options :

1. Voltage controlled current source
2. Voltage controlled voltage source

3. Current controlled current source

4. Current controlled voltage source

Question Number : 51 Question Id : 2999654011 Question Type : MCQ Display Question Number : Yes Is Question Mandatory : No Single Line Question Option : No Option Orientation : Vertical

How many address lines are needed to address each memory location in a 2048×4 memory chip?

Options :

1. 10

2. 11

3. 12

4. 18

Question Number : 52 Question Id : 2999654012 Question Type : MCQ Display Question Number : Yes Is Question Mandatory : No Single Line Question Option : No Option Orientation : Vertical

The range of signed decimal numbers that can be represented by 6-bit 1's complement number is _____.

Options :

1. -31 to +31

2. -63 to + 63

3. -64 to +63

4. -32 to +31

Question Number : 53 Question Id : 2999654013 Question Type : MCQ Display Question Number : Yes Is Question Mandatory : No Single Line Question Option : No Option Orientation : Vertical

The switching speed of CMOS is now _____.

Options :

1. Competitive with TTL
2. Slower than TTL
3. Three times that of TTL
4. Twice that of TTL

Question Number : 54 Question Id : 2999654014 Question Type : MCQ Display Question Number : Yes Is Question Mandatory : No Single Line Question Option : No Option Orientation : Vertical

The Boolean function $Y = AB + CD$ is to be realized using only 2-input NAND gates. The minimum number of gates required is _____.

Options :

1. 2
2. 3
3. 4
4. 5

Question Number : 55 Question Id : 2999654015 Question Type : MCQ Display Question Number : Yes Is Question Mandatory : No Single Line Question Option : No Option Orientation : Vertical

Find the value of the Boolean function F in the below circuit.

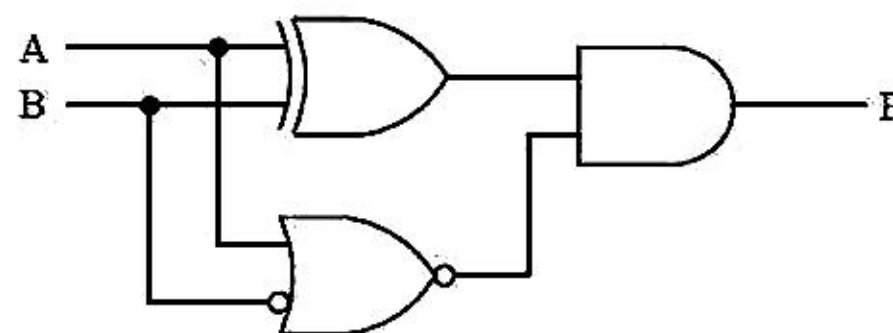

Options :

1. $\bar{A} B$
2. $A \bar{B}$
3. $\bar{A} \bar{B}$

4. AB

Question Number : 56 Question Id : 2999654016 Question Type : MCQ Display Question Number : Yes Is Question Mandatory : No Single Line Question Option : No Option Orientation : Vertical

Indicate which of the following logic gates can be used to realize all possible combinational logic functions.

Options :

1. OR gates only
2. NAND gates only
3. EX-OR gates only
4. AND gates only

Question Number : 57 Question Id : 2999654017 Question Type : MCQ Display Question Number : Yes Is Question Mandatory : No Single Line Question Option : No Option Orientation : Vertical

An SR flip-flop can be converted into T flip-flop by connecting _____ to Q and _____ to \bar{Q} .

Options :

1. \bar{S}, \bar{R}
2. S, \bar{R}
3. \bar{S}, R
4. S, R

Question Number : 58 Question Id : 2999654018 Question Type : MCQ Display Question Number : Yes Is Question Mandatory : No Single Line Question Option : No Option Orientation : Vertical

The output Y of a 2-bit comparator is logic 1 whenever the 2-bit input A is greater than the 2-bit input B. The number of combinations for which the output is logic 1, is _____.

Options :

1. 4
2. 6
3. 8
4. 10

Question Number : 59 Question Id : 2999654019 Question Type : MCQ Display Question Number : Yes Is Question Mandatory : No Single Line Question Option : No Option Orientation : Vertical

In 8085 microprocessor how many devices can be interfaced in I/O mapped I/O technique?

Options :

1. 256 I/O devices
2. 128 I/O devices
3. 65536 I/O devices
4. 1024 I/O devices

Question Number : 60 Question Id : 2999654020 Question Type : MCQ Display Question Number : Yes Is Question Mandatory : No Single Line Question Option : No Option Orientation : Vertical

An asynchronous mod- 6 counter consists of 3 flip-flops and a combination circuit of 2 input gate(s). The combination circuit consists of _____.

Options :

1. one AND gate
2. one OR gate
3. one AND gate and one OR gate
4. two AND gates

Question Number : 61 Question Id : 2999654021 Question Type : MCQ Display Question Number : Yes Is Question Mandatory : No Single Line Question Option : No Option Orientation : Vertical

How many 2X1 multiplexers are needed to construct 32X1 multiplexer?

Options :

1. 31
2. 32
3. 16
4. 17

Question Number : 62 Question Id : 2999654022 Question Type : MCQ Display Question Number : Yes Is Question Mandatory : No Single Line Question Option : No Option Orientation : Vertical

A darlington emitter follower circuit is sometimes used in the output stage of a TTL gate in order to _____.

Options :

1. increase its I_{OL}
2. reduce its I_{OH}
3. increase its speed of operation
4. reduce power dissipation

Question Number : 63 Question Id : 2999654023 Question Type : MCQ Display Question Number : Yes Is Question Mandatory : No Single Line Question Option : No Option Orientation : Vertical

The advantage of using a dual slope ADC in a digital voltmeter is that _____.

Options :

1. its conversion time is small
2. its accuracy is high
3. it gives out in BCD format

4. it does not require a comparator

Question Number : 64 Question Id : 2999654024 Question Type : MCQ Display Question Number : Yes Is Question Mandatory : No Single Line Question Option : No Option Orientation : Vertical

How can parallel data be taken out of a shift register simultaneously?

Options :

1. Use the Q output of the first FF
2. Use the Q output of the last FF
3. Tie all of the Q outputs together
4. Use the Q output of each FF

Question Number : 65 Question Id : 2999654025 Question Type : MCQ Display Question Number : Yes Is Question Mandatory : No Single Line Question Option : No Option Orientation : Vertical

A system is said to be dynamic if the output of the system depends on the _____.

Options :

1. Past input
2. Present input
3. Future input
4. Present and future inputs

Question Number : 66 Question Id : 2999654026 Question Type : MCQ Display Question Number : Yes Is Question Mandatory : No Single Line Question Option : No Option Orientation : Vertical

The trigonometric Fourier series of an even function does not have the _____.

Options :

1. DC term
2. cosine term
3. sine term

4. odd harmonic terms

Question Number : 67 Question Id : 2999654027 Question Type : MCQ Display Question Number : Yes Is Question Mandatory : No Single Line Question Option : No Option Orientation : Vertical

The DFT of real and odd sequence is _____.

Options :

1. purely imaginary
2. purely real
3. complex
4. imaginary and complex

Question Number : 68 Question Id : 2999654028 Question Type : MCQ Display Question Number : Yes Is Question Mandatory : No Single Line Question Option : No Option Orientation : Vertical

The Fourier transform of the exponential signal e^{jm_0t} is _____.

Options :

1. a constant
2. a rectangular gate.
3. an impulse
4. a series of impulses

Question Number : 69 Question Id : 2999654029 Question Type : MCQ Display Question Number : Yes Is Question Mandatory : No Single Line Question Option : No Option Orientation : Vertical

If sequence $x(n)$ of length 5 and sequence $h(n)$ of length 4 are linearly convoluted using FFT algorithm, the number of zeros to be padded to each of the sequences respectively are _____.

Options :

1. 0 and 1

2. 3 and 4

3. 4 and 5

4. 5 and 4

Question Number : 70 Question Id : 2999654030 Question Type : MCQ Display Question Number : Yes Is Question Mandatory : No Single Line Question Option : No Option Orientation : Vertical

The autocorrelation function of an energy signal has _____.

Options :

1. no symmetry

2. conjugate symmetry

3. odd symmetry

4. even symmetry

Question Number : 71 Question Id : 2999654031 Question Type : MCQ Display Question Number : Yes Is Question Mandatory : No Single Line Question Option : No Option Orientation : Vertical

The FT of a rectangular pulse existing between $t = -T/2$ to $t = T/2$ is a _____.

Options :

1. sinc squared function

2. sine squared function

3. sine function

4. sinc function

Question Number : 72 Question Id : 2999654032 Question Type : MCQ Display Question Number : Yes Is Question Mandatory : No Single Line Question Option : No Option Orientation : Vertical

The 4-point Discrete Fourier Transform of a discrete time sequence $\{1, 0, 2, 3\}$ is _____.

Options :

1. $[0, -2 + 2j, 2, -2-2j]$
2. $[2, 2+2j, 6, 2 - 2j]$
3. $[6, 1 - 3j, 2, 1 + 3j]$
4. $[6, -1+3j, 0, -1-3j]$

Question Number : 73 Question Id : 2999654033 Question Type : MCQ Display Question Number : Yes Is Question Mandatory : No Single Line Question Option : No Option Orientation : Vertical

The inverse Laplace transform of $\frac{e^{-s}}{s}$ is _____.

Options :

1. e^{-t}
2. $u(t-1)$
3. $\delta(t - 1)$
4. e^t

Question Number : 74 Question Id : 2999654034 Question Type : MCQ Display Question Number : Yes Is Question Mandatory : No Single Line Question Option : No Option Orientation : Vertical

The transfer function of a zero-order-hold system is _____.

Options :

1. $(1/s)(1 + e^{-sT})$
2. $(1/s)(1 - e^{-sT})$
3. $1 - (1/s)e^{-sT}$
4. $1 + (1/s)e^{-sT}$

Question Number : 75 Question Id : 2999654035 Question Type : MCQ Display Question Number : Yes Is Question

Mandatory : No Single Line Question Option : No Option Orientation : Vertical

Inverse Fourier transform of $\text{sgn}(\omega)$ is _____.

Options :

1. $j/\pi t$
2. 1
3. $U(t)$
4. 0

Question Number : 76 Question Id : 2999654036 Question Type : MCQ Display Question Number : Yes Is Question Mandatory : No Single Line Question Option : No Option Orientation : Vertical

A linear discrete time system has the characteristic equation, $z^3 - 0.81z = 0$. The system _____.

Options :

1. is stable
2. is marginally stable
3. is unstable
4. stability cannot be assessed from the given information

Question Number : 77 Question Id : 2999654037 Question Type : MCQ Display Question Number : Yes Is Question Mandatory : No Single Line Question Option : No Option Orientation : Vertical

Which one of the following is a linear system?

Options :

1. $Y(n) = X(n) \times X(n-1)$
2. $Y(n) = X(n) + X(n-10)$
3. $Y(n) = X^2(n)$
4. $Y(n) = X(n) \times X(n-1)$ and $Y(n) = X^2(n)$

Question Number : 78 Question Id : 2999654038 Question Type : MCQ Display Question Number : Yes Is Question Mandatory : No Single Line Question Option : No Option Orientation : Vertical

A continuous time function $x(t)$ is periodic with period T . The function is sampled uniformly with a sampling period T_s . In which one of the following cases is the sampled signal periodic?

Options :

1. $T = \sqrt{2} T_s$

2. $T = 1.2 T_s$

3. Always

4. $T = 1.4 T_s$

Question Number : 79 Question Id : 2999654039 Question Type : MCQ Display Question Number : Yes Is Question Mandatory : No Single Line Question Option : No Option Orientation : Vertical

The steady state error of a stable type '0' unity feedback system for a unit step function is _____.

Options :

1. 0

2. ∞

3. $\frac{1}{1+K_p}$

4. $\frac{1}{K_p}$

Question Number : 80 Question Id : 2999654040 Question Type : MCQ Display Question Number : Yes Is Question Mandatory : No Single Line Question Option : No Option Orientation : Vertical

What is the transfer function for the negative feedback system with Gain $G(s)$ and feedback $H(s)$?

Options :

1. $\left(\frac{G(s)}{1+G(s)H(s)}\right)$

2. $\left(\frac{G(s)}{1-G(s)H(s)}\right)$

3. $\left(\frac{G(s)}{1-G(s)}\right)$

4. $G(s)H(s)$

Question Number : 81 Question Id : 2999654041 Question Type : MCQ Display Question Number : Yes Is Question Mandatory : No Single Line Question Option : No Option Orientation : Vertical

A linear time invariant system has an impulse response e^{2t} , $t > 0$. If the initial conditions are zero and the input is e^{3t} , the output for $t > 0$ is _____.

Options :

1. $e^{3t} - e^{2t}$

2. e^{5t}

3. $e^{3t} + e^{2t}$

4. $e^{3t} - e^t$

Question Number : 82 Question Id : 2999654042 Question Type : MCQ Display Question Number : Yes Is Question Mandatory : No Single Line Question Option : No Option Orientation : Vertical

Regenerative feedback implies feedback with _____.

Options :

1. oscillations

2. negative sign
3. ramp input
4. positive input

Question Number : 83 Question Id : 2999654043 Question Type : MCQ Display Question Number : Yes Is Question Mandatory : No Single Line Question Option : No Option Orientation : Vertical

By performing cascading and/or summing/differencing operations using transfer function blocks $G_1(s)$ and $G_2(s)$, one CANNOT realize a transfer function of the form _____.

Options :

1. $G_1(s)G_2(s)$
2. $G_1(s)/G_2(s)$
3. $G_1(s) [1/G_1(s) + G_2(s)]$
4. $G_1(s)[1/G_1(s) - G_2(s)]$

Question Number : 84 Question Id : 2999654044 Question Type : MCQ Display Question Number : Yes Is Question Mandatory : No Single Line Question Option : No Option Orientation : Vertical

The Transient response of a system is mainly due to _____.

Options :

1. inertia forces
2. internal forces
3. stored energy
4. friction

Question Number : 85 Question Id : 2999654045 Question Type : MCQ Display Question Number : Yes Is Question Mandatory : No Single Line Question Option : No Option Orientation : Vertical

For a second order system, damping ratio (ξ) is $0 < \xi < 1$, then the roots of the characteristic polynomial are _____.

Options :

1. Real but not equal
2. Real and equal
3. Complex conjugates
4. Imaginary

Question Number : 86 Question Id : 2999654046 Question Type : MCQ Display Question Number : Yes Is Question Mandatory : No Single Line Question Option : No Option Orientation : Vertical

Addition of Zeros in transfer function causes which of the following?

Options :

1. Lead compensation
2. Lag compensation
3. Lead-lag compensation
4. Does not effect the system performance

Question Number : 87 Question Id : 2999654047 Question Type : MCQ Display Question Number : Yes Is Question Mandatory : No Single Line Question Option : No Option Orientation : Vertical

A critically damped, continuous-time, second order system, when sampled will have (in Z domain) _____.

Options :

1. A simple pole
2. double pole on real axis
3. Double pole on imaginary axis

a pair of complex conjugate poles

4.

Question Number : 88 Question Id : 2999654048 Question Type : MCQ Display Question Number : Yes Is Question Mandatory : No Single Line Question Option : No Option Orientation : Vertical

What is the range of K for stability of unity feedback system whose open loop

transfer function is $G(s) = \frac{K}{s(s+1)(s+2)}$?

Options :

1. $-6 < K < 6$

1.

2. $0 < K < 6$

2.

3. $K > 6$

3.

4. $K < -6$

4.

Question Number : 89 Question Id : 2999654049 Question Type : MCQ Display Question Number : Yes Is Question Mandatory : No Single Line Question Option : No Option Orientation : Vertical

A causal system having the transfer function $G(s) = (1/s) + 2$ is excited with $10u(t)$.

The time at which the output reaches 99% of its steady state value is _____.

Options :

1. 2.7 sec

1.

2. 2.5 sec

2.

3. 2.3 sec

3.

4. 2.1 sec

4.

Question Number : 90 Question Id : 2999654050 Question Type : MCQ Display Question Number : Yes Is Question Mandatory : No Single Line Question Option : No Option Orientation : Vertical

A controller With transfer function can be introduced in cascade with open loop transfer function to modify_____.

Options :

1. transient response only
2. steady state response only
3. both transient and steady state responses
4. frequency response only

Question Number : 91 Question Id : 2999654051 Question Type : MCQ Display Question Number : Yes Is Question Mandatory : No Single Line Question Option : No Option Orientation : Vertical

An electromechanical closed-loop control system has the following characteristic equation $s^3 + 6Ks^2 + (K + 2) s + 8 = 0$, where K is the forward gain of the system.

The condition for closed loop stability is _____.

Options :

1. $K = 0.528$
2. $K = 2$
3. $K = 0$
4. $K = -2.258$

Question Number : 92 Question Id : 2999654052 Question Type : MCQ Display Question Number : Yes Is Question Mandatory : No Single Line Question Option : No Option Orientation : Vertical

In a Bode magnitude plot, which one of the following slopes would be exhibited at high frequencies by a 4th order all-pole system?

Options :

1. -80 dB/decade
2. -40 dB/decade

3. +40 dB/decade
4. 80 dB/decade

Question Number : 93 Question Id : 2999654053 Question Type : MCQ Display Question Number : Yes Is Question Mandatory : No Single Line Question Option : No Option Orientation : Vertical

The minimum transmission bandwidth to transmit message of highest frequency f_m using DSBSC stream is _____.

Options :

1. f_m
2. $2f_m$
3. $f_m/2$
4. $3f_m$

Question Number : 94 Question Id : 2999654054 Question Type : MCQ Display Question Number : Yes Is Question Mandatory : No Single Line Question Option : No Option Orientation : Vertical

A single side band modulation is normally used for _____.

Options :

1. Land and air mobile communication, military communication
2. Transmission of good quality music
3. TV broadcasting
4. Stereo broadcasting

Question Number : 95 Question Id : 2999654055 Question Type : MCQ Display Question Number : Yes Is Question Mandatory : No Single Line Question Option : No Option Orientation : Vertical

For the signal $m(t) = 4\sin(100 \pi t)$, Nyquist sampling rate is _____.

Options :

1. 50 Hz

2. 100 Hz
3. 200 Hz
4. 400 Hz

Question Number : 96 Question Id : 2999654056 Question Type : MCQ Display Question Number : Yes Is Question Mandatory : No Single Line Question Option : No Option Orientation : Vertical

In an envelope detector the input is an AM signal, which is expressed as $X_{AM}(t) = A(1 + m \cos \omega_m t) \cos \omega_c t$, where m is a constant, $0 < m < 1$, and $\omega_c \gg \omega_m$. The maximum value of time constant RC of the detector to follow the message envelope is given by _____.

Options :

1. $RC \leq \frac{1}{\omega_m} \frac{\sqrt{1-m^2}}{m}$
2. $RC \leq \frac{1}{\omega_m} \frac{m}{\sqrt{1-m^2}}$
3. $RC > \frac{1}{\omega_m} \frac{\sqrt{1-m^2}}{m}$
4. $RC \leq \frac{1}{\omega_m} \frac{\sqrt{1-m^2}}{m^2}$

Question Number : 97 Question Id : 2999654057 Question Type : MCQ Display Question Number : Yes Is Question Mandatory : No Single Line Question Option : No Option Orientation : Vertical

If the number of bits per sample in a PCM system is increased from n to $n + 1$, the improvement in signal to quantization noise is _____.

Options :

1. 3 dB
2. 6 dB

3. $2n$ dB

4. n dB

Question Number : 98 Question Id : 2999654058 Question Type : MCQ Display Question Number : Yes Is Question Mandatory : No Single Line Question Option : No Option Orientation : Vertical

A super heterodyne receiver with an IF of 465 KHz is tuned to a signal at 1000 KHz.

The image frequency is _____.

Options :

1. 930 KHz

2. 1650 KHz

3. 1465 KHz

4. 1930 KHz

Question Number : 99 Question Id : 2999654059 Question Type : MCQ Display Question Number : Yes Is Question Mandatory : No Single Line Question Option : No Option Orientation : Vertical

For a bit-rate of 8 kbps, the best possible values of the transmitted frequencies in a coherent binary FSK system are _____.

Options :

1. 16 kHz and 20 kHz

2. 20 kHz and 32 kHz

3. 20 kHz and 40 kHz

4. 32 kHz and 40 kHz

Question Number : 100 Question Id : 2999654060 Question Type : MCQ Display Question Number : Yes Is Question Mandatory : No Single Line Question Option : No Option Orientation : Vertical

The channel capacity of an ideal AWGN channel with infinite bandwidth is _____.

(where $\eta/2$ = double sided power spectral density of noise)

Options :

1. ∞
2. 0
3. $1.44 S/\eta$
4. $5.44 S/\eta$

Question Number : 101 Question Id : 2999654061 Question Type : MCQ Display Question Number : Yes Is Question Mandatory : No Single Line Question Option : No Option Orientation : Vertical

Coherent demodulation of FSK signal can be effected using _____.

Options :

1. correlation receiver
2. band pass filters and envelope detectors
3. matched filters
4. discrimination detection

Question Number : 102 Question Id : 2999654062 Question Type : MCQ Display Question Number : Yes Is Question Mandatory : No Single Line Question Option : No Option Orientation : Vertical

Consider two random variables 'X' and 'Y', $Y = \cos\pi X$, where the pdf of 'X'

$$f(X) = \begin{cases} 1 & -\frac{1}{2} < X < \frac{1}{2} \\ 0 & \text{otherwise.} \end{cases}$$

Then variance of 'Y' is _____.

Options :

1. 0.76
2. 0.096
3. 0.56

4. 0.26

Question Number : 103 Question Id : 2999654063 Question Type : MCQ Display Question Number : Yes Is Question Mandatory : No Single Line Question Option : No Option Orientation : Vertical

A memory less source emits n symbols each with a probability p . The entropy of the source as a function of n _____.

Options :

1. increases as $\log n$
2. decreases as $\log (1/n)$
3. increases as n
4. increases as $n \log n$

Question Number : 104 Question Id : 2999654064 Question Type : MCQ Display Question Number : Yes Is Question Mandatory : No Single Line Question Option : No Option Orientation : Vertical

The figure of merit ($\gamma = \frac{S_o / N_o}{S_i / N_i}$) for the DSB with carrier by considering sinusoidal modulation is _____.

Options :

1. 1
2. $\frac{m}{\sqrt{2+m^2}}$
3. $1/3$
4. $\frac{m^2}{2+m^2}$

Question Number : 105 Question Id : 2999654065 Question Type : MCQ Display Question Number : Yes Is Question Mandatory : No Single Line Question Option : No Option Orientation : Vertical

A binary symmetric channel (BSC) has a transition probability of $1/8$. If the binary transmit symbol X is such that $P(X = 0) = 9/10$, then the probability of error for an optimum receiver will be _____.

Options :

1. $7/80$
2. $63/80$
3. $9/10$
4. $1/10$

Question Number : 106 Question Id : 2999654066 Question Type : MCQ Display Question Number : Yes Is Question Mandatory : No Single Line Question Option : No Option Orientation : Vertical

A signal $m_1(t)$ is band limited to 3.6 KHz and the other signals $m_2(t)$ and $m_3(t)$ are band limited to 1.2 KHz. These signals are transmitted by means of TDM. The output of the commutator is quantized with 1024 levels, then the bit rate is _____.

Options :

1. 120 bits/sec
2. 12 K bits/sec
3. 120 M bits/sec
4. 120 K bits/sec

Question Number : 107 Question Id : 2999654067 Question Type : MCQ Display Question Number : Yes Is Question Mandatory : No Single Line Question Option : No Option Orientation : Vertical

The electric field intensity E due to solid spherical charges is _____.

Options :

1. Inversely proportional to distance square
2. Directly proportional to distance square

3. Independent of the distance

4. Inversely proportional to root of the distance

Question Number : 108 Question Id : 2999654068 Question Type : MCQ Display Question Number : Yes Is Question Mandatory : No Single Line Question Option : No Option Orientation : Vertical

The electric field strength at a distance point P, due to a point charge, +q, located at the origin, is $100 \mu\text{V/m}$. If the point charge is now enclosed by a perfectly conducting metal sheet sphere whose centre is at the origin, the electric field strength at the point P, outside the sphere becomes _____.

Options :

1. zero

2. $100 \mu\text{V/m}$

3. $-100 \mu\text{V/m}$

4. $50 \mu\text{V/m}$

Question Number : 109 Question Id : 2999654069 Question Type : MCQ Display Question Number : Yes Is Question Mandatory : No Single Line Question Option : No Option Orientation : Vertical

The coordinates of the point on the Z-axis in a cylindrical coordinate system are

Options :

1. $(0,0,Z)$

2. $(0,\phi,0)$

3. $(0,\phi,Z)$

4. $(0,\pi,Z)$

Question Number : 110 Question Id : 2999654070 Question Type : MCQ Display Question Number : Yes Is Question

Mandatory : No Single Line Question Option : No Option Orientation : Vertical

Vector potential is a vector _____.

Options :

1. whose curl is equal to the magnetic flux density
2. whose curl is equal to the electric field intensity
3. whose divergence is equal to the electric potential
4. which is equal to the vector product $E \times H$

Question Number : 111 Question Id : 2999654071 Question Type : MCQ Display Question Number : Yes Is Question Mandatory : No Single Line Question Option : No Option Orientation : Vertical

A transmission line of length $n\lambda / 4$ ($n = \text{integer}$) is short circuited at the far end. The input impedance is _____.

Options :

1. Zero
2. ∞
3. Z_0
4. $\frac{Z_0}{2}$

Question Number : 112 Question Id : 2999654072 Question Type : MCQ Display Question Number : Yes Is Question Mandatory : No Single Line Question Option : No Option Orientation : Vertical

A uniform plane wave in the free space is normally incident on a infinitely thick dielectric slab (dielectric constant $\epsilon_r = 9$) the magnitude of the reflection coefficient is _____.

Options :

1. 0

2. 0.3

3. 0.5

4. 0.8

Question Number : 113 Question Id : 2999654073 Question Type : MCQ Display Question Number : Yes Is Question Mandatory : No Single Line Question Option : No Option Orientation : Vertical

The conduction current density J_C is _____.

Options :

1. $\frac{\partial D}{\partial t}$

2. $\frac{\partial B}{\partial t}$

3. $\frac{\partial E}{\partial t}$

4. σE

Question Number : 114 Question Id : 2999654074 Question Type : MCQ Display Question Number : Yes Is Question Mandatory : No Single Line Question Option : No Option Orientation : Vertical

A transmitting antenna radiates 251 W isotropically. A receiving antenna located 100 m away from the transmitting antenna has an effective aperture of 500 cm². The total power received by the antenna is _____.

Options :

1. 10 nW

2. 1 μW

3. 20 μW

4. 100 μW

Question Number : 115 Question Id : 2999654075 Question Type : MCQ Display Question Number : Yes Is Question Mandatory : No Single Line Question Option : No Option Orientation : Vertical

A transmission line of 100 characteristic impedance is connected to a load of $100+j100$. The normalized impedance is _____.

Options :

1. $1 + j1$
2. $\frac{100}{100+j100}$
3. $10^4 + j10^4$
4. $j100$

Question Number : 116 Question Id : 2999654076 Question Type : MCQ Display Question Number : Yes Is Question Mandatory : No Single Line Question Option : No Option Orientation : Vertical

The return loss of devices found to be 20 dB. The voltage standing wave ratio (VSWR) and magnitude of reflection coefficient are respectively _____.

Options :

1. 1.22 and 0.1
2. 0.81 and 0.1
3. -1.22 and 0.1
4. 2.44 and 0.2

Question Number : 117 Question Id : 2999654077 Question Type : MCQ Display Question Number : Yes Is Question Mandatory : No Single Line Question Option : No Option Orientation : Vertical

The depth of Penetration is _____.

Options :

1. $\delta = \sqrt{\frac{\omega\mu\sigma}{2}}$

2.
$$\delta = \sqrt{\frac{2}{\omega\mu\sigma}}$$

3.
$$\delta = \sqrt{\omega\mu\sigma}$$

4.
$$\delta = \sqrt{\frac{1}{\omega\mu\sigma}}$$

Question Number : 118 Question Id : 2999654078 Question Type : MCQ Display Question Number : Yes Is Question Mandatory : No Single Line Question Option : No Option Orientation : Vertical

The VSWR can have any value between _____.

Options :

1. 0 and 1

2. -1 and +1

3. 0 and ∞

4. 1 and ∞

Question Number : 119 Question Id : 2999654079 Question Type : MCQ Display Question Number : Yes Is Question Mandatory : No Single Line Question Option : No Option Orientation : Vertical

The directivity of short dipole is given by _____.

Options :

1. 1.5

2. 1.64

3. 2.03

4. 2.54

Question Number : 120 Question Id : 2999654080 Question Type : MCQ Display Question Number : Yes Is Question Mandatory : No Single Line Question Option : No Option Orientation : Vertical

For a Hertz dipole antenna, the half power beam width (HPBW) in the E-plane is _____.

Options :

1. 360°

2. 180°

3. 90°

4. 45°