

AAT-2016

Time: 3 hours Maximum Marks: 300

READ THE INSTRUCTIONS CAREFULLY

- This sealed booklet is your Question Paper. Do not break the seal till you are instructed to do so.
- Immediately after breaking the seal of the booklet, verify that the booklet contains 20 pages and that all the 14 questions along with the options are legible. Report immediately about any missing or torn sheet in this booklet and ask for a replacement of the booklet from the invigilator. No replacement will be allowed after 9:15 am.
- Write your Name, Roll Number, All India Rank and other details in the space provided and nowhere else. No distinctive / identification mark of any type is to be put anywhere else in this booklet.
- Answers are to be written only in the booklet and within the space provided beside / below each Question and nowhere else. Answers written in non-designated place will not be evaluated.
- Blank spaces are provided within this booklet for rough work.
- Do not deface this booklet; do not detach or mutilate any sheet from the booklet. Such acts lead to disqualification.
- The question paper has five sections.
- All the questions are compulsory.

Total Marks Obtained:

In Numbers:

In words:

Signature of the Examiner with date

Signature of the Scrutinizer with date

AAT-2016

NAME:

ROLL NO:

ALL INDIA RANK:

CATEGORY:

CATEGORY RANK (IF APPLICABLE):

EXAMINATION CENTRE:

I have read all the instructions and shall abide by them.

Signature of the Candidate

Signature of the Invigilator after verification of identity and other details

DO NOT BREAK THE SEAL WITHOUT BEING INSTRUCTED TO DO SO BY THE INVIGILATOR

See the back cover of this booklet for the marking scheme

2911

This Page is kept blank intentionally

DO NOT WRITE ON THIS PAGE

SECTION A: Architectural Awareness (Maximum Marks: 60)

This section contains **FOUR** questions. Question 1 carries **30** marks.
Questions 2, 3 and 4 carry **10** marks each. There is **NO** negative marking.

Q.1 This section contains **10** multiple choice questions. Each question has four options, out of which **ONLY ONE** is correct. Mark the correct option with a tick mark. (10 × 3 = 30 Marks)

(i) Layout of the ancient city **Mahenjo-daro** was based on

- | | | | |
|--------------------------|-------------------|--------------------------|------------------|
| <input type="checkbox"/> | Radial Pattern | <input type="checkbox"/> | Circular Pattern |
| <input type="checkbox"/> | Grid-Iron Pattern | <input type="checkbox"/> | Linear Pattern |

(ii) Which of the following locations is well known for 'Terracotta' temples?

- | | | | |
|--------------------------|---------------|--------------------------|-----------|
| <input type="checkbox"/> | Bishnupur | <input type="checkbox"/> | Humphri |
| <input type="checkbox"/> | Mahabalipuram | <input type="checkbox"/> | Jaisalmer |

(iii) Primary colours in pigments are

- | | | | |
|--------------------------|--------------------|--------------------------|---------------------|
| <input type="checkbox"/> | Red, Green & Blue | <input type="checkbox"/> | Red, Blue & Yellow |
| <input type="checkbox"/> | Red, Green & Black | <input type="checkbox"/> | Red, Green & Yellow |

(iv) 'Grafting' of plants refers to

- Graffiti made on the plants
- Graphite used as fertilizer for the plants
- Implanting one plant into another
- Graphic presentation using plants

(v) The geometric profile of **Tajmahal** in plan is

- | | | | |
|--------------------------|-------------|--------------------------|-----------|
| <input type="checkbox"/> | Rectangular | <input type="checkbox"/> | Hexagonal |
| <input type="checkbox"/> | Circular | <input type="checkbox"/> | Octagonal |

(vi) The flower that influenced the form of **Bahai temple** in Delhi is

- | | | | |
|--------------------------|-----------|--------------------------|---------|
| <input type="checkbox"/> | Rose | <input type="checkbox"/> | Lotus |
| <input type="checkbox"/> | Sunflower | <input type="checkbox"/> | Jasmine |

(vii) Padmanabhapuram palace is well known for its

- | | |
|--|--|
| <input type="checkbox"/> Mud architecture | <input type="checkbox"/> Marble architecture |
| <input type="checkbox"/> Wooden architecture | <input type="checkbox"/> Laterite architecture |

(viii) Which of the following is NOT a geometric drawing?

- | | |
|--|--|
| <input type="checkbox"/> Freehand Drawing | <input type="checkbox"/> Isometric Drawing |
| <input type="checkbox"/> Perspective Drawing | <input type="checkbox"/> Axonometric Drawing |

(ix) The term 'GRIHA' stands for

- Green Rating for Integrated Housing Assessment
- Global Rating for Industrial Habitat Assessment
- Global Rating for International Heritage Assessment
- Green Rating for Integrated Habitat Assessment

(x) Consider the figure given in the box below :

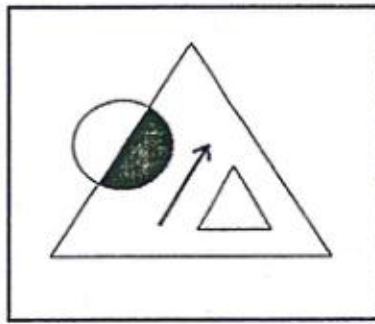

Which one of the following options is identical to the given figure?

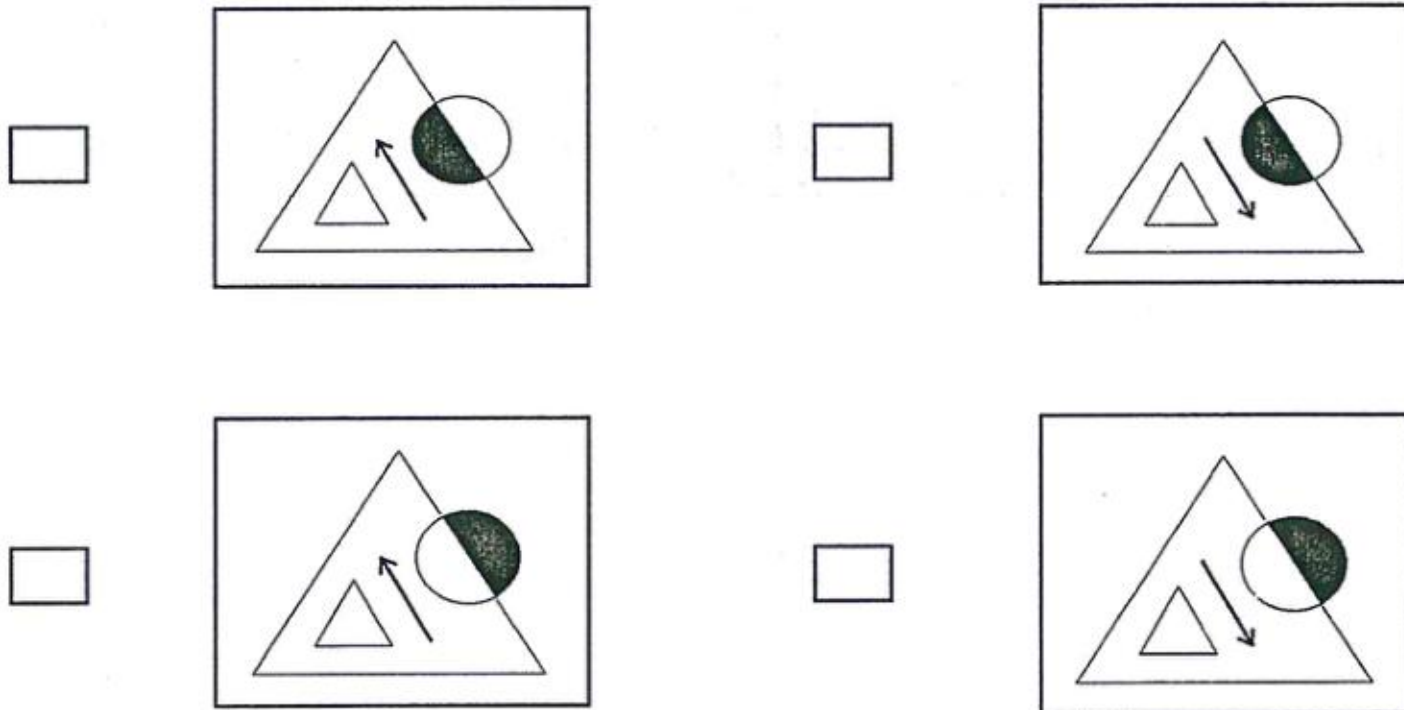





Q.2 Match the following books in **Group I** with their respective authors in **Group II**.
(5 × 2 = 10 Marks)

Group I		Group II
A. Towards a New Architecture	<input type="checkbox"/>	P. Jawaharlal Nehru
B. The Fountainhead	<input type="checkbox"/>	Q. Mahatma Gandhi
C. The Tale of Two Cities	<input type="checkbox"/>	R. Charles Dickens
D. Letters to a Young Architect	<input type="checkbox"/>	S. Ayn Rand
E. Discovery of India	<input type="checkbox"/>	T. Le Corbusier
		U. Christopher Charles Benninger

Q.3 Match the following Indian cities in **Group I** with their adjacent rivers listed in **Group II**.
(5 × 2 = 10 Marks)

Group I		Group II
A. Vijaywada	<input type="checkbox"/>	P. Sabarmati
B. Haridwar	<input type="checkbox"/>	Q. Krishna
C. Agra	<input type="checkbox"/>	R. Godavari
D. Ahmedabad	<input type="checkbox"/>	S. Yamuna
E. Guwahati	<input type="checkbox"/>	T. Brahmaputra
		U. Ganga

Q.4 Match the following signage in **Group-I** with their corresponding subjects in **Group-II**.
 (5 × 2 = 10 Marks)

Group I		Group II	
A.	 <input type="text"/>	P.	Narrow Bridge
B.	 <input type="text"/>	Q.	Level Crossing
C.	 <input type="text"/>	R.	Hospital
D.	 <input type="text"/>	S.	Hump or Rough Road
E.	 <input type="text"/>	T.	Pedestrian Crossing
		U.	Restriction

SECTION B: Geometrical Drawing (Maximum Marks: 60)
This section contains **THREE** questions. Each question carries **20 Marks**.

- Q.5 Draw the three dimensional view of the solid formed with the following card board profile by folding along the dotted lines and joining the open edges. **(20 Marks)**

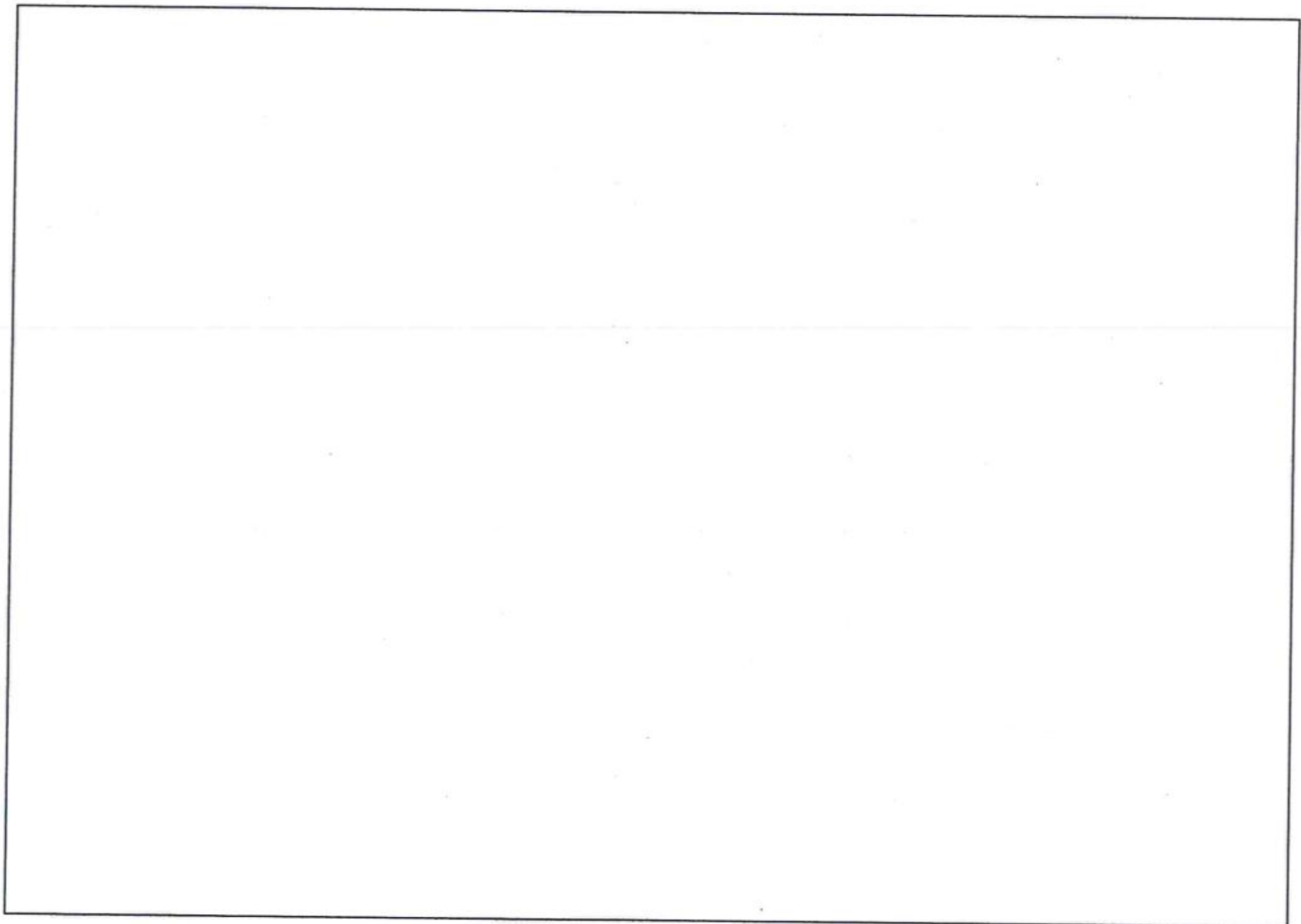
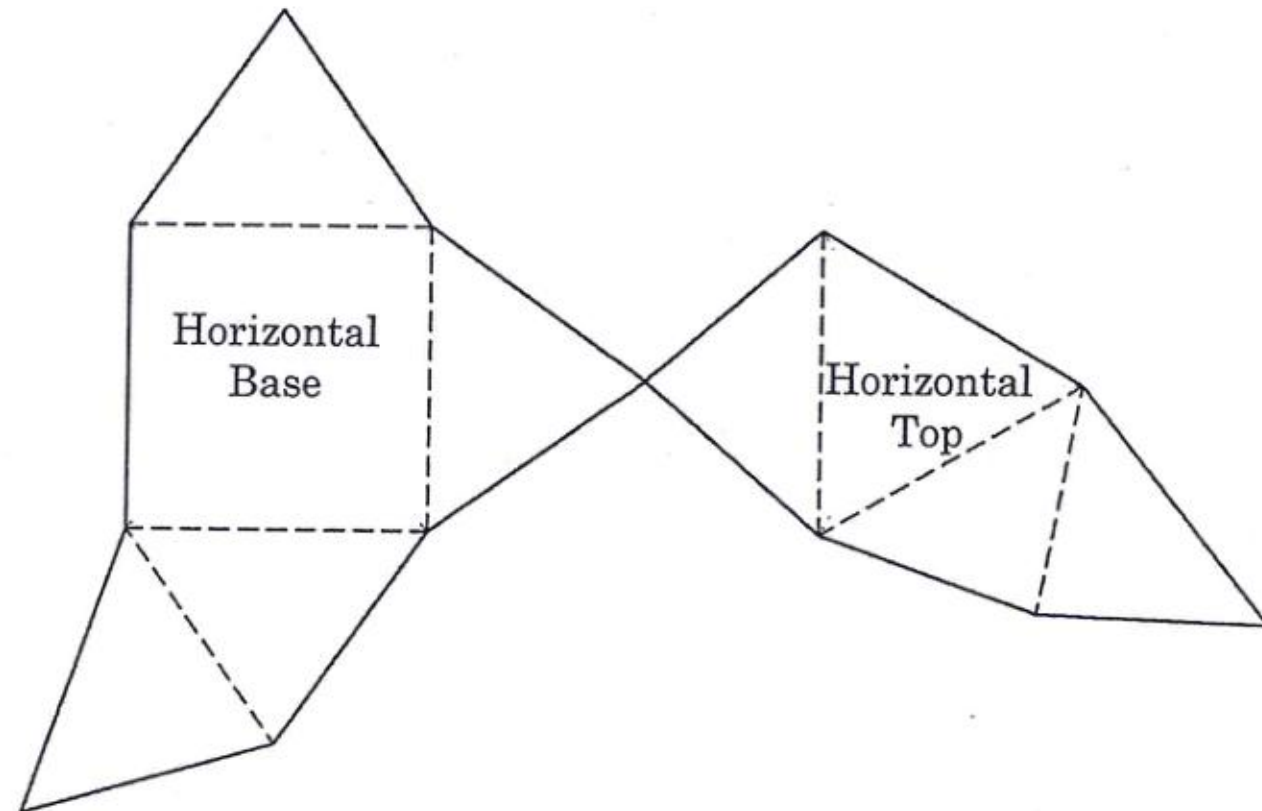

Q.6 Draw the enlarged view of the following figure within the given box below. (20 Marks)

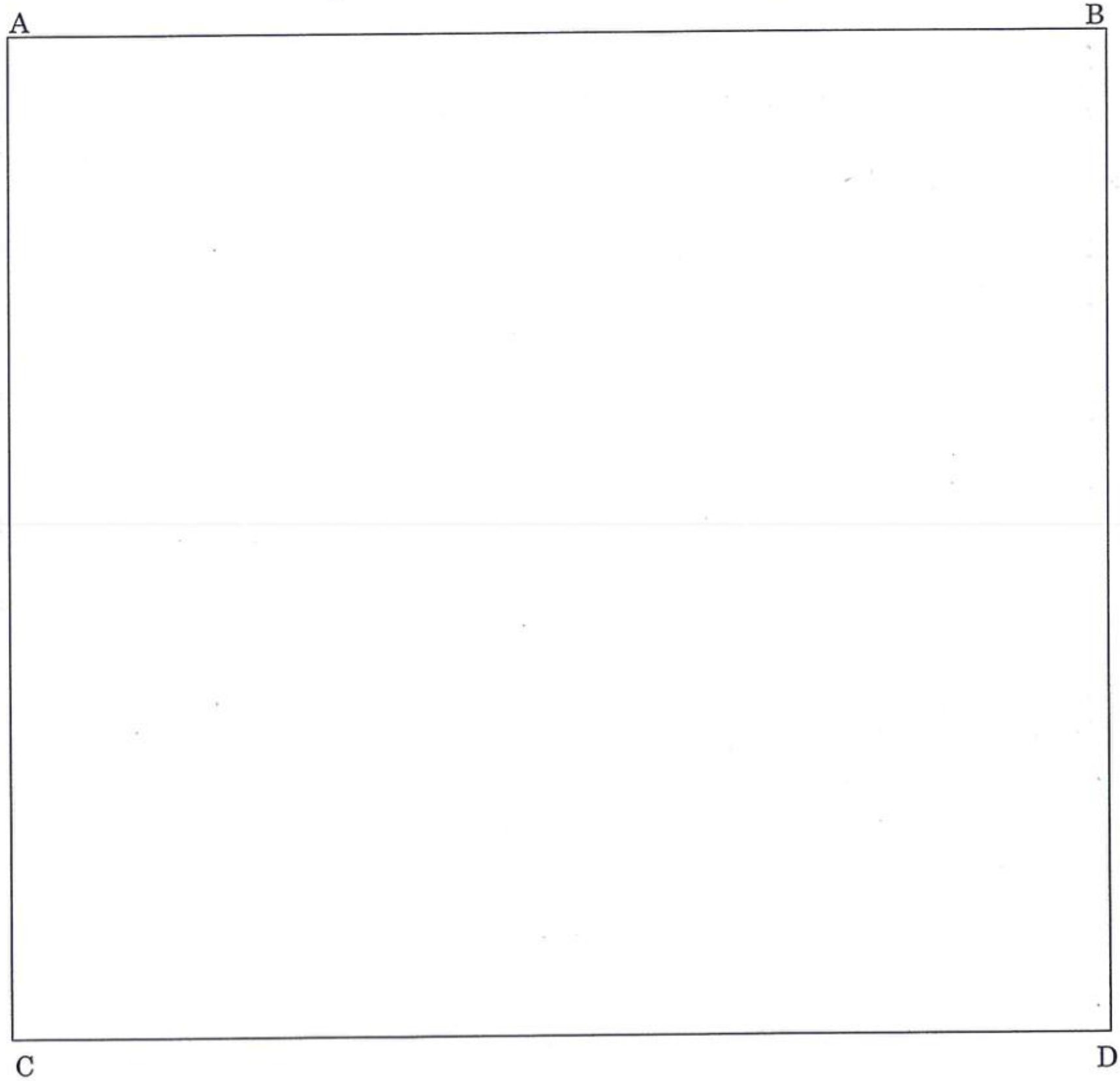
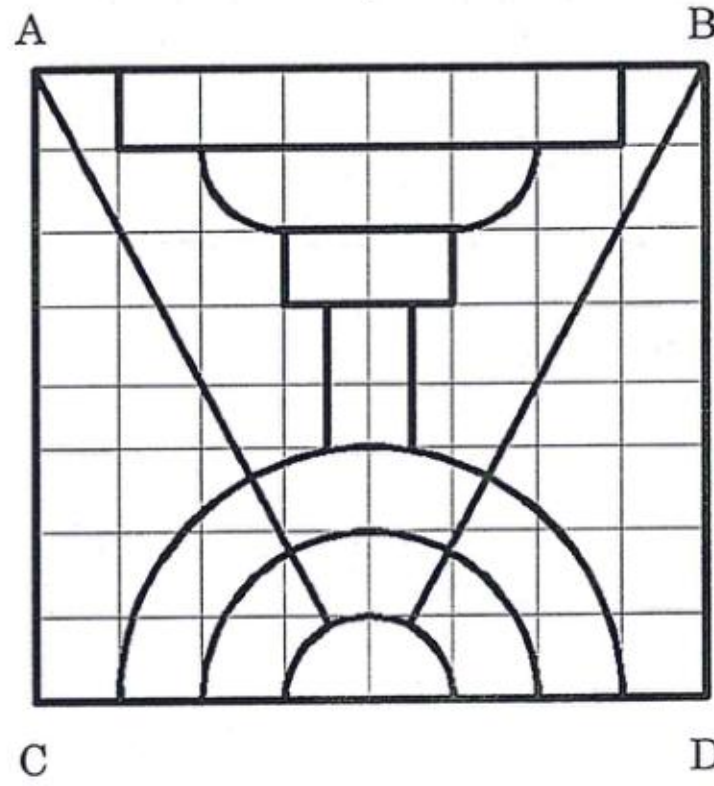

Q.7 Draw **mirror images** of the pattern given in the top-left corner box, considering the mirror lines shown as AA and BB, in all the other empty boxes given below. (20 Marks)

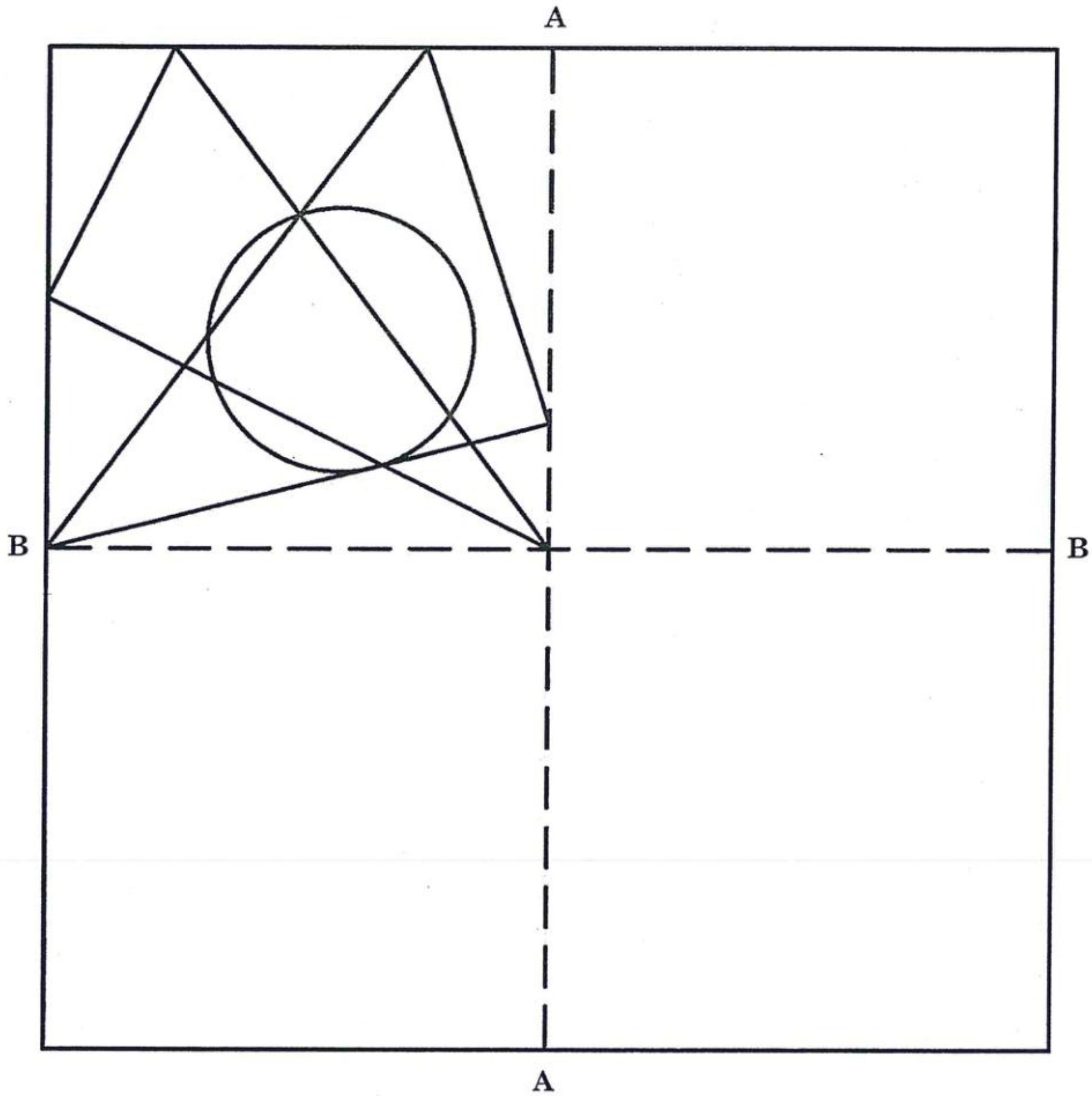

SECTION C: Three Dimensional Perception (Maximum Marks: 60)

This section contains **THREE** questions. Each question carries **20 Marks**.

- Q.8 Extend each letter and number towards the third dimension in a single direction within the given box. (20 Marks)



Q.9 Draw the **Top view**, **Front view** and **Side view** (left or right) of the given three-dimensional object given below. Dimensions shown are in centimeter. **(20 Marks)**

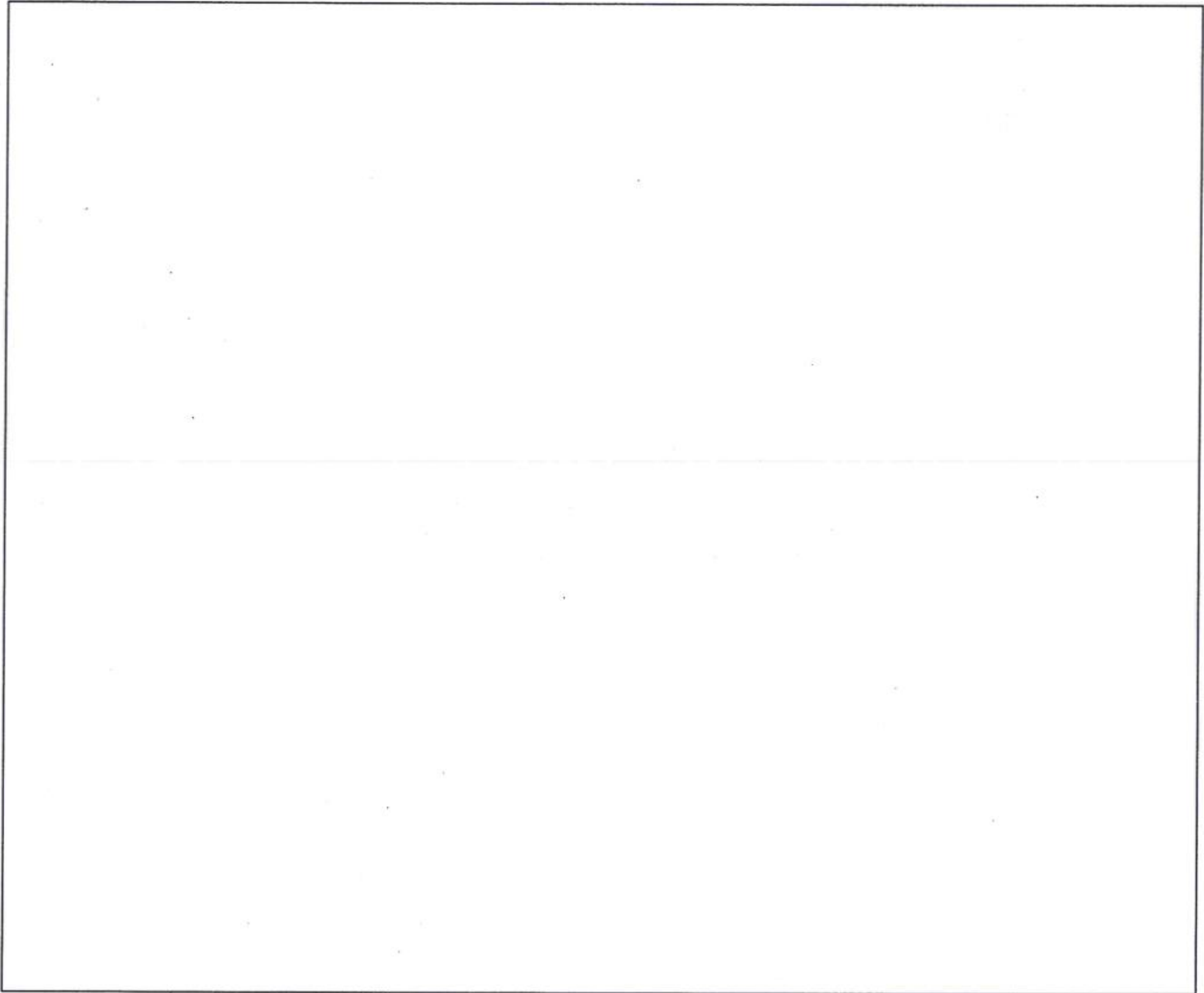
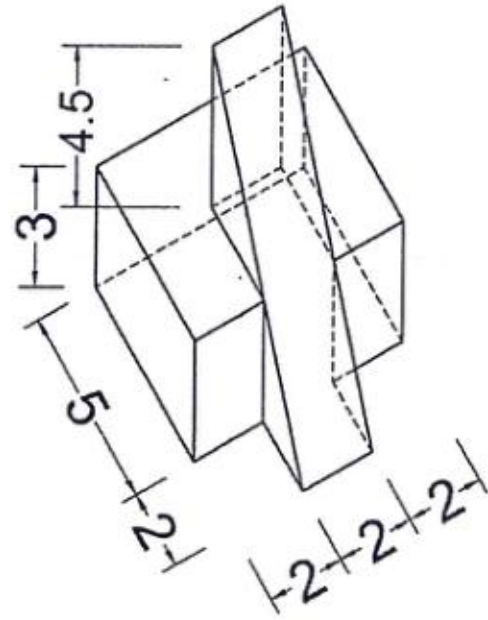

Q.10 Draw the three dimensional view of the object from the direction indicated by the arrow, generated from the following views, inside the box below. Dimensions shown are in centimeter.
(20 Marks)

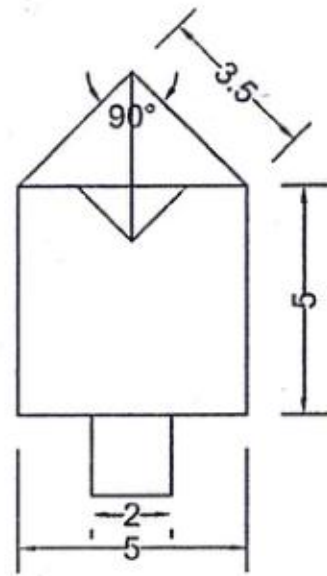

Top View

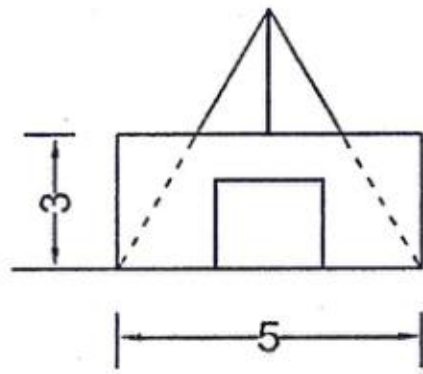

Front View

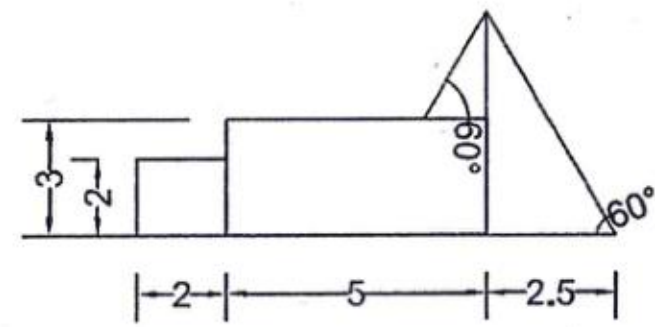

Side View

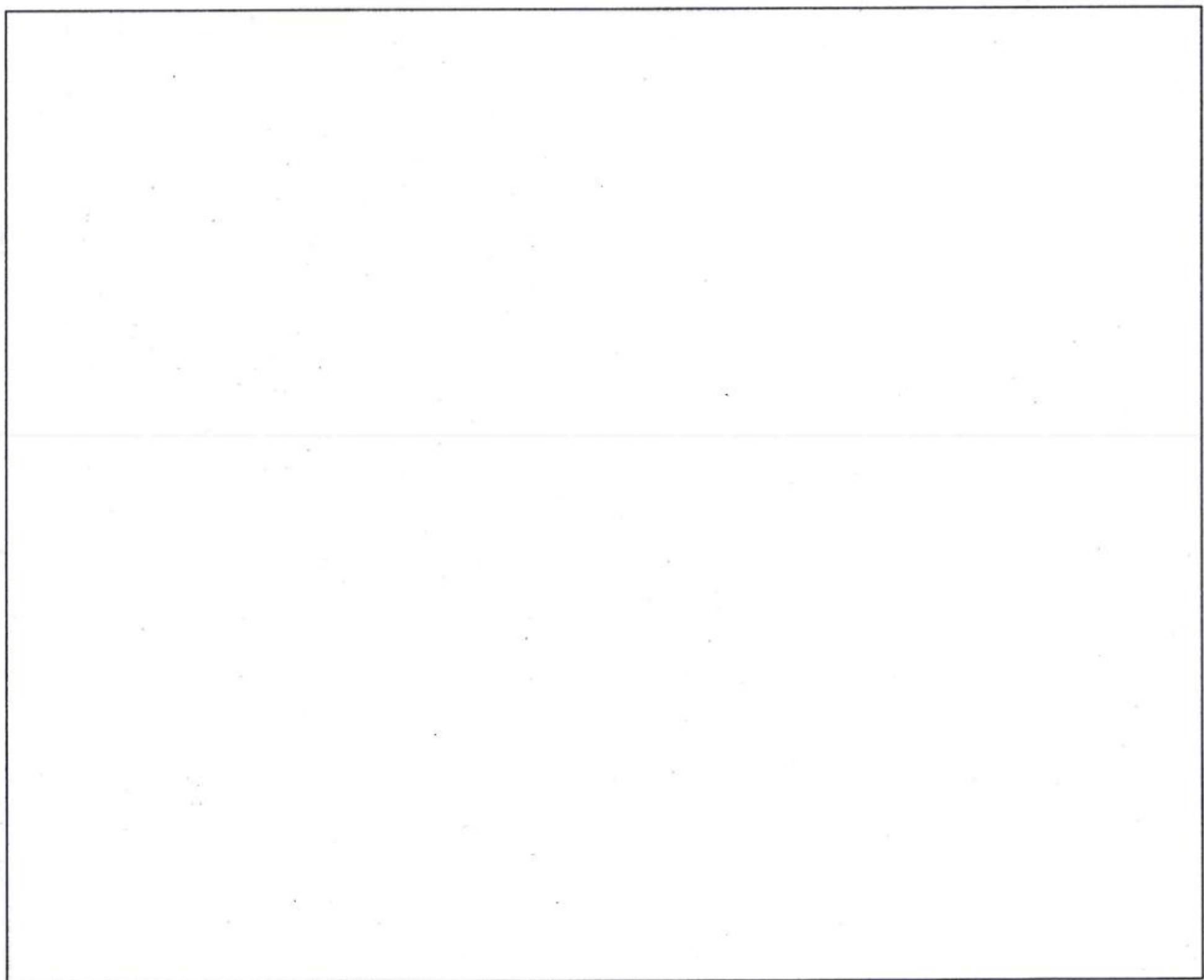

SECTION D: Imagination and Aesthetic Sensitivity (Maximum Marks: 60)

This section contains **TWO** questions. Each question carries **30 Marks**.

Q.11 Color the picture given below using maximum four colours so as to make it a pleasing composition. (30 Marks)

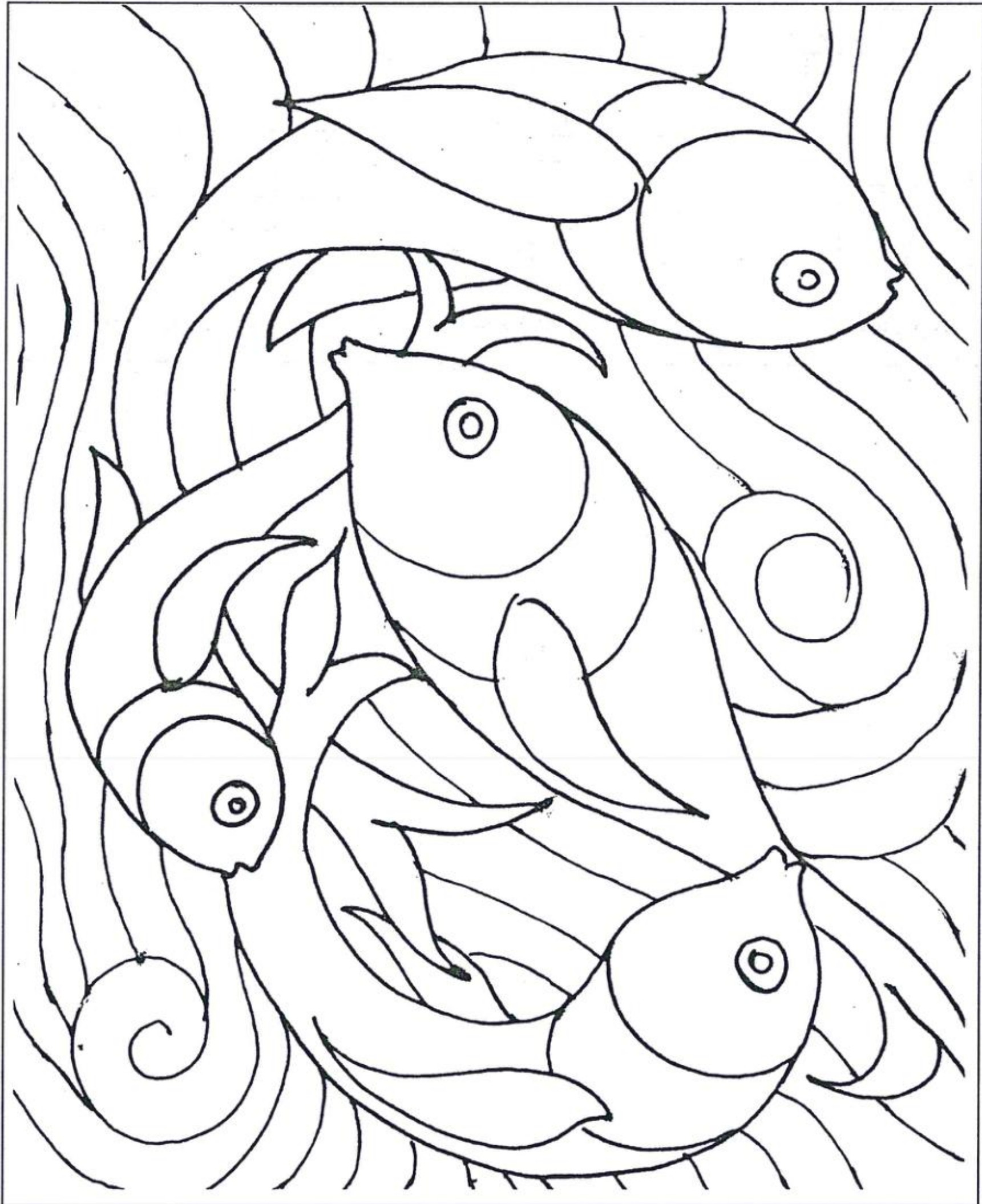

Q.12 Make an attractive composition with the following given numbers of 2D shapes, of varying sizes and overlapping them within the box given below, and paint the composition with three different colours. **(30 Marks)**

4 circles

6 squares

8 equilateral triangles

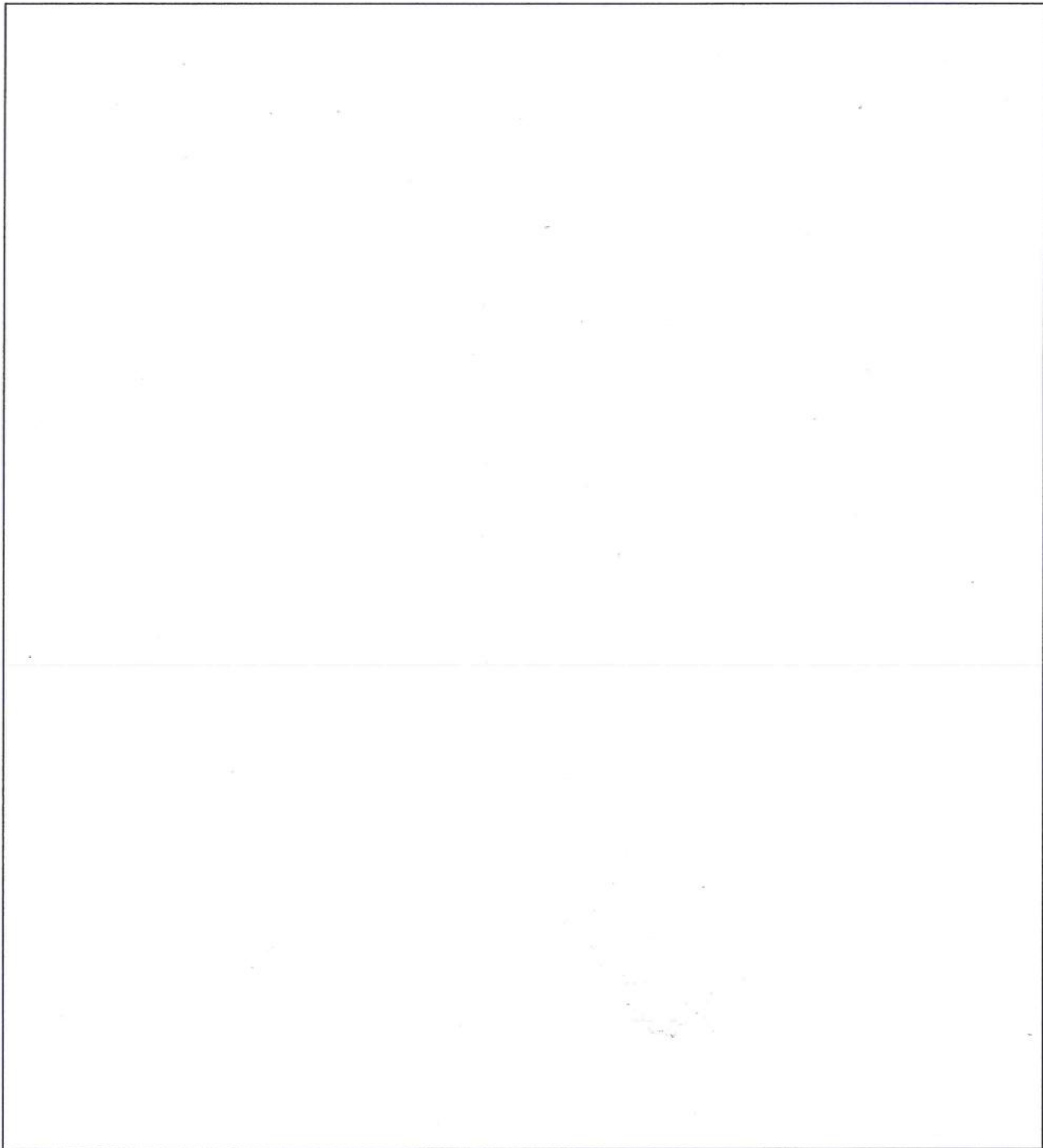

SECTION E: Freehand Drawing (Maximum Marks: 60)
This section contains **TWO** questions. Each question carries **30** Marks.

Q.13 Make a pencil sketch with shades and shadows, of a rocking chair, and a side table with a glass partially filled with water and an open magazine placed on top of the table. **(30 Marks)**

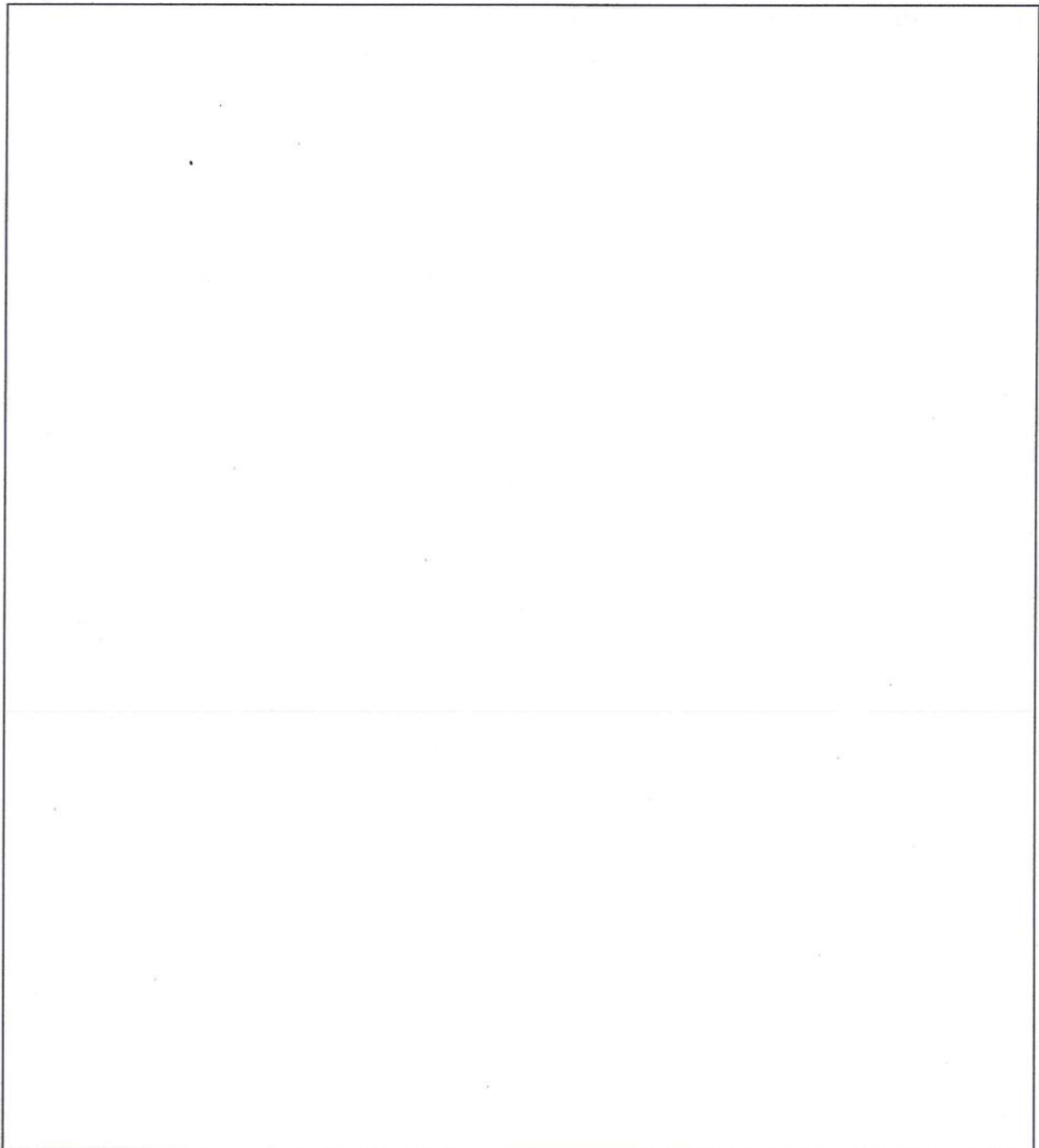

Q.14 Draw a sketch of a **Boat Jetty** from your memory, within the box given below, comprising of elements such as people, boats, water side kiosks, hawkers and trees etc. **(30 Marks)**

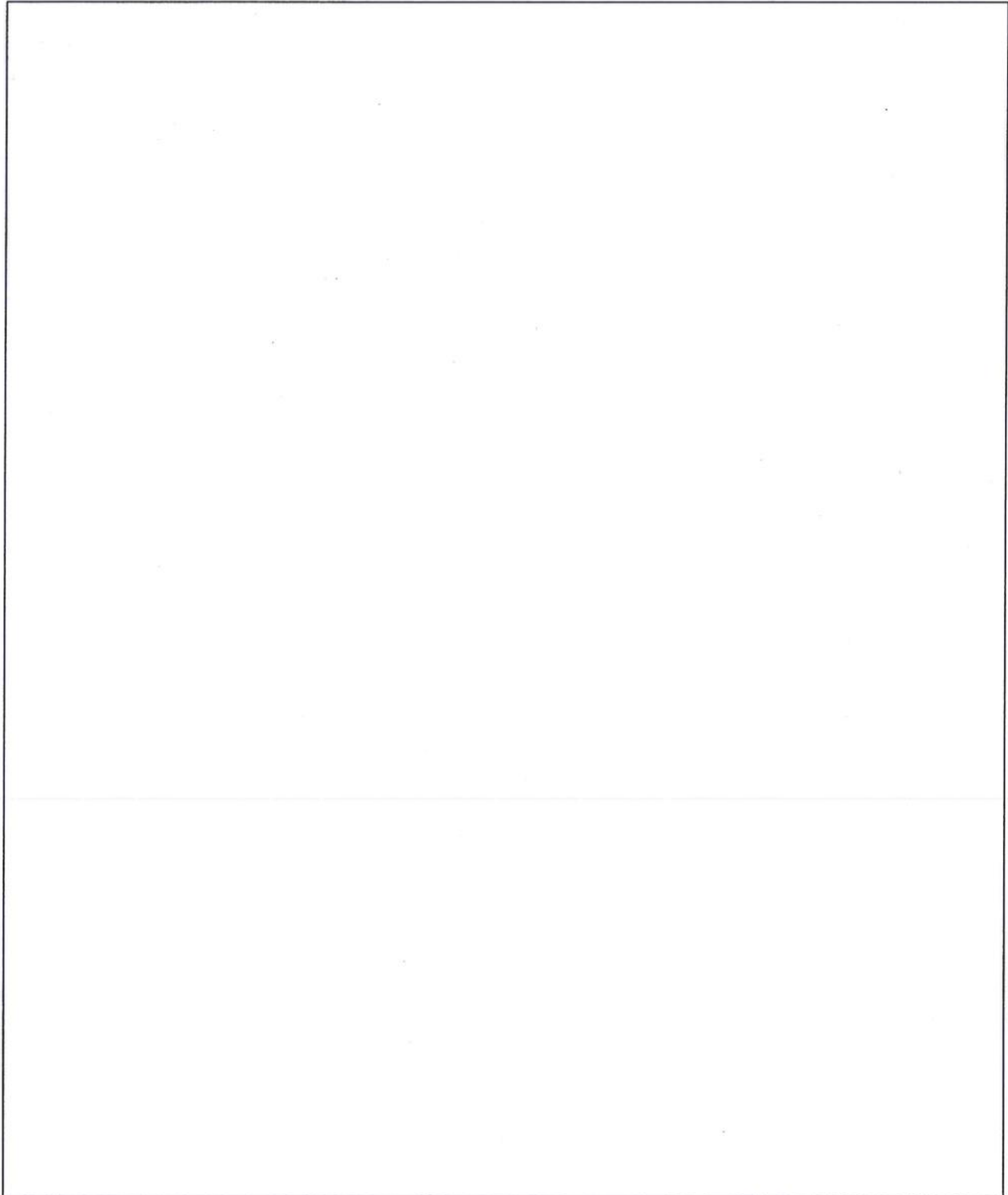

END OF THE QUESTION PAPER

AAT-2016

16/20

SPACE FOR ONLY ROUGH WORK

SPACE FOR ONLY ROUGH WORK

SPACE FOR ONLY ROUGH WORK

DO NOT WRITE ON THIS PAGE

Section-wise Distribution of Marks

SECTIONS	QUESTION NO.	PAGE NO.	MAXIMUM MARKS	MARKS OBTAINED
Section A Architectural Awareness	Q. 1	3	30	
	Q. 2	5	10	
	Q. 3	5	10	
	Q. 4	6	10	
Section B Geometrical Drawing	Q. 5	7	20	
	Q. 6	8	20	
	Q. 7	9	20	
Section C Three Dimensional Perception	Q. 8	10	20	
	Q. 9	11	20	
	Q. 10	12	20	
Section D Imagination and Aesthetic Sensitivity	Q. 11	13	30	
	Q. 12	14	30	
Section E Freehand Drawing	Q. 13	15	30	
	Q. 14	16	30	
TOTAL MARKS			300	

SEAL