

**Question Paper Name:** Electrical Engineering 11th May 2017 Shift 2  
**Subject Name:** Electrical Engineering  
**Duration:** 120

Electrical Engineering

**Display Number Panel:** Yes  
**Group All Questions:** No

**Question Number : 1 Question Id : 871112481 Display Question Number : Yes Single Line Question Option : No Option Orientation : Vertical**

The matrix  $A$  has eigen values  $\lambda_i \neq 0$ . Then  $A^{-1} - 2I + A$  has eigen values

**Options :**

1.  $1 + 2\lambda_i + \lambda_i^2$
2.  $(1/\lambda_i) - 2 + \lambda_i$
3.  $1 - 2\lambda_i + \lambda_i^2$
4.  $1 - 2(1/\lambda_i) + (1/\lambda_i^2)$

**Question Number : 2 Question Id : 871112482 Display Question Number : Yes Single Line Question Option : No Option Orientation : Vertical**

The function  $f(x) = 10 + x^6$

**Options :**

1. is a decreasing function of  $x$
2. has a minimum value at  $x = 0$
3. has neither a maximum nor a minimum value at  $x = 0$
4. has a maximum value at  $x = 0$

Options :

1.  $\sin x$
2.  $\cos x$
3.  $x \sin x$
4.  $x \cos x$

Question Number : 4 Question Id : 871112484 Display Question Number : Yes Single Line Question Option : No Option Orientation : Vertical

$$\frac{1}{D^2+D+1} \sin x =$$

Options :

1.  $\sin x$
2.  $\cos x$
3.  $-\cos x$
4.  $-\sin x$

Question Number : 5 Question Id : 871112485 Display Question Number : Yes Single Line Question Option : No Option Orientation : Vertical

The harmonic conjugate of  $e^x \cos y$  is

Options :

1.  $e^x \sin y$
2.  $e^x (\sin y + \cos y)$
3.  $e^{-x} \sin y$
4.  $e^{-x} (\sin y - \cos y)$

Question Number : 6 Question Id : 871112486 Display Question Number : Yes Single Line Question Option : No Option Orientation : Vertical

The value of the complex integral  $\int \frac{3z^2 + 7z + 1}{z + 1} dz$  over  $C : |z| = \frac{1}{2}$  is

Options :

2.

$$\pi i/2$$

3.

$$2 \pi i$$

4.

Question Number : 7 Question Id : 871112487 Display Question Number : Yes Single Line Question Option : No Option Orientation : Vertical

Which of the following is true for mean and variance of Binomial distribution?

Options :

1. Mean < Variance

2. Mean = Variance

3. Mean > Variance

4. Mean  $\times$  Variance = 1

Question Number : 8 Question Id : 871112488 Display Question Number : Yes Single Line Question Option : No Option Orientation : Vertical

An unbiased die with faces marked 1, 2, 3, 4, 5, 6 is rolled four times. Out of four face values obtained, the probability that the minimum face value is not less than 2 and the maximum face value is not greater than 5 is

Options :

1.  $16/81$

2.  $2/9$

3.  $80/81$

4.  $8/9$

Question Number : 9 Question Id : 871112489 Display Question Number : Yes Single Line Question Option : No Option Orientation : Vertical

In the case of bisection method, the convergence is

Options :

1. Very fast

3. Linear

4. Quadratic

Question Number : 10 Question Id : 871112490 Display Question Number : Yes Single Line Question Option : No Option Orientation : Vertical

For the data

X	2	4	6	8
f(x)	3	5	6	7

$\int_2^8 f(x) dx$  when found by the Trapezoidal rule is

Options :

1. 16
2. 18
3. 25
4. 32

Question Number : 11 Question Id : 871112491 Display Question Number : Yes Single Line Question Option : No Option Orientation : Vertical

In the circuit shown below, what is the value of  $R_L$  for which the power delivered to it is maximum?

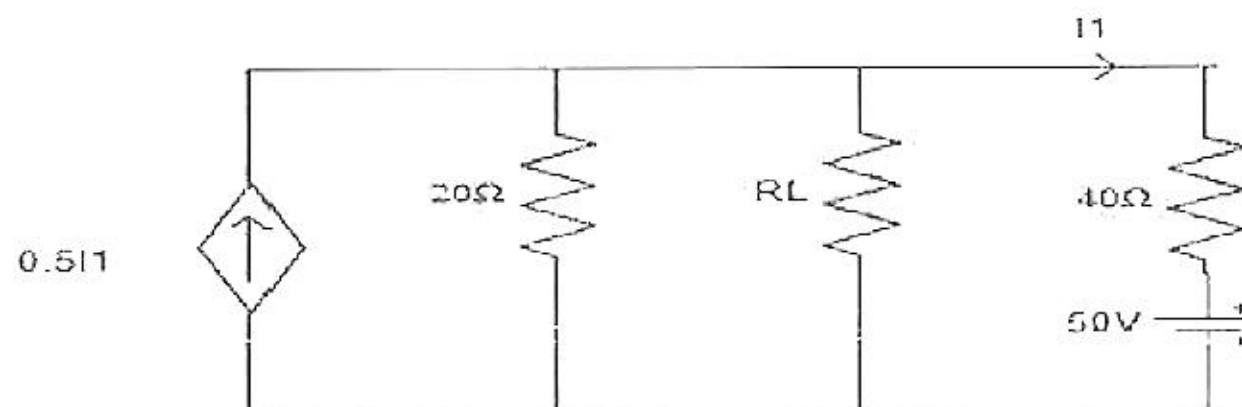

Options :

1.  $16 \Omega$
2.  $60 \Omega$
3.  $10 \Omega$
4.  $6 \Omega$



THE OPEN CIRCUIT PARAMETERS OF THE FOLLOWING CIRCUIT IS

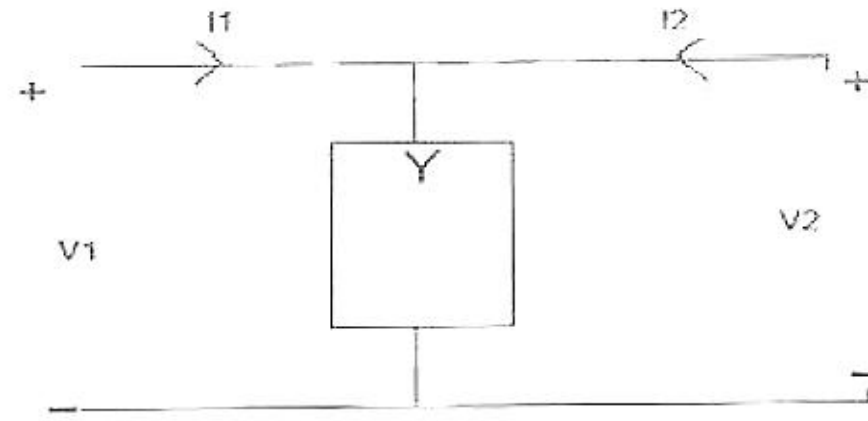

Options :

1.  $\begin{bmatrix} Y & Y \\ Y & Y \end{bmatrix}$
2.  $\begin{bmatrix} 1/Y & 1/Y \\ 1/Y & 1/Y \end{bmatrix}$
3.  $\begin{bmatrix} Y & 1/Y \\ 1/Y & Y \end{bmatrix}$
4.  $\begin{bmatrix} 1/Y & Y \\ Y & 1/Y \end{bmatrix}$

Question Number : 13 Question Id : 871112493 Display Question Number : Yes Single Line Question Option : No Option Orientation : Vertical

For the circuit shown in below figure the Thevenin voltage and resistance looking into X-Y terminals respectively are \_\_\_\_\_.

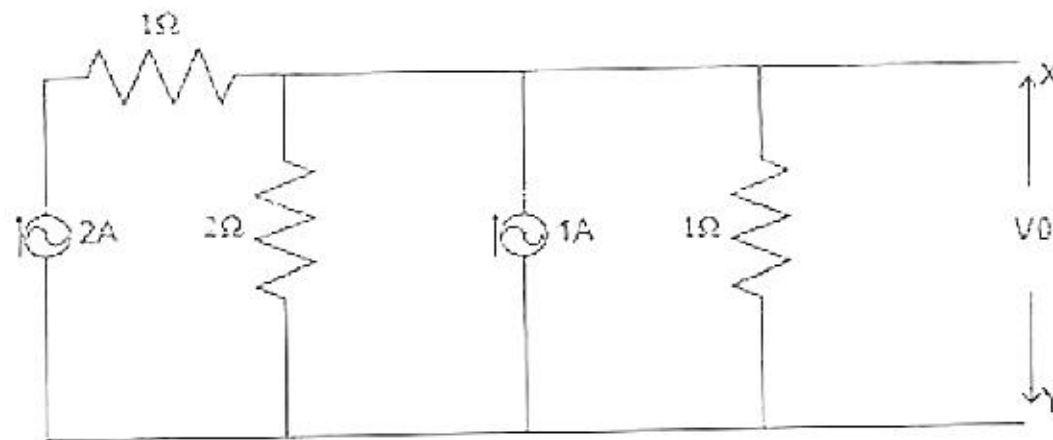

Options :

1. 1 V, 1 Ω

3.  
2 V, 2/3 Ω  
4.

Question Number : 14 Question Id : 871112494 Display Question Number : Yes Single Line Question Option : No Option Orientation : Vertical

The RC circuit shown in below figure is

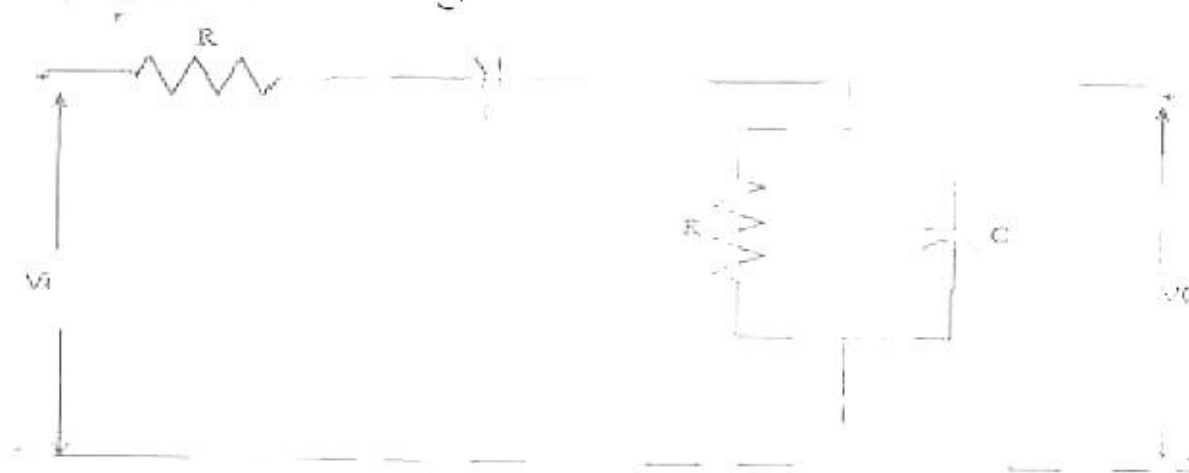

Options :

1. a low pass filter  
2. a high pass filter  
3. a band pass filter  
4. a band reject filter

Question Number : 15 Question Id : 871112495 Display Question Number : Yes Single Line Question Option : No Option Orientation : Vertical

Which of the following to be satisfied by the circuit shown such that the step response  $y(t)$  has no oscillations?

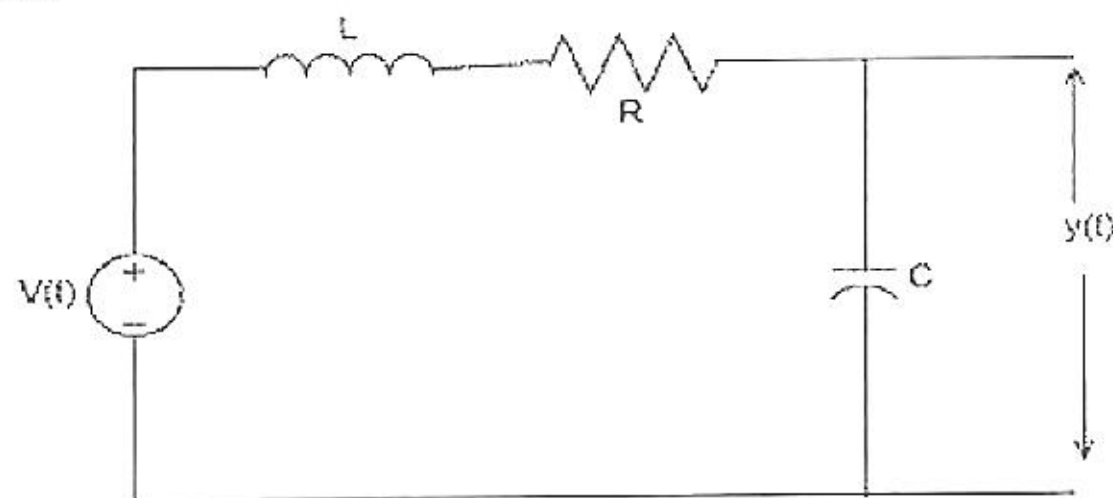

Options :

1.  $R \geq \frac{1}{2} \sqrt{\frac{L}{C}}$

3.  $R \geq \sqrt{\frac{L}{C}}$

4.  $R = \sqrt{\frac{1}{2C}}$

Question Number : 16 Question Id : 871112496 Display Question Number : Yes Single Line Question Option : No Option Orientation : Vertical

The ABCD parameters of an ideal 1:n transformer shown in the following figure are

1.n	0
0	x

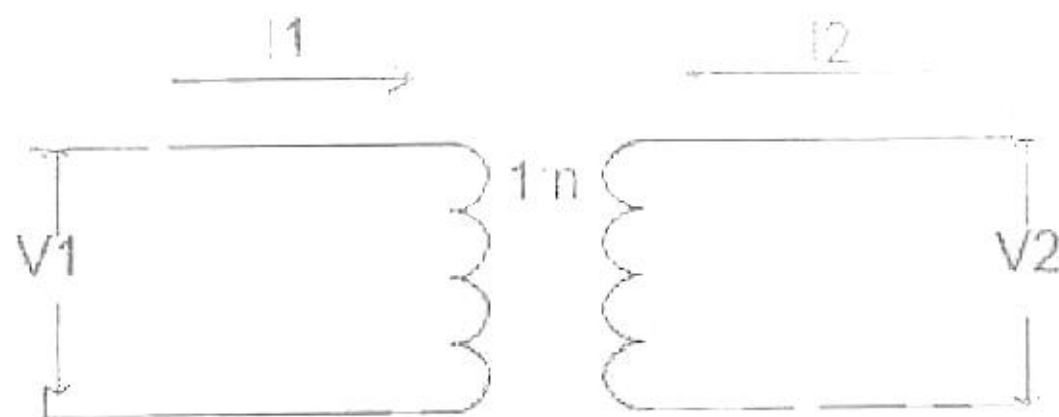

The value of x will be

Options :

1.  $n$

2.  $1/n$

3.  $1/n^2$

4.  $n^2$

Question Number : 17 Question Id : 871112497 Display Question Number : Yes Single Line Question Option : No Option Orientation : Vertical

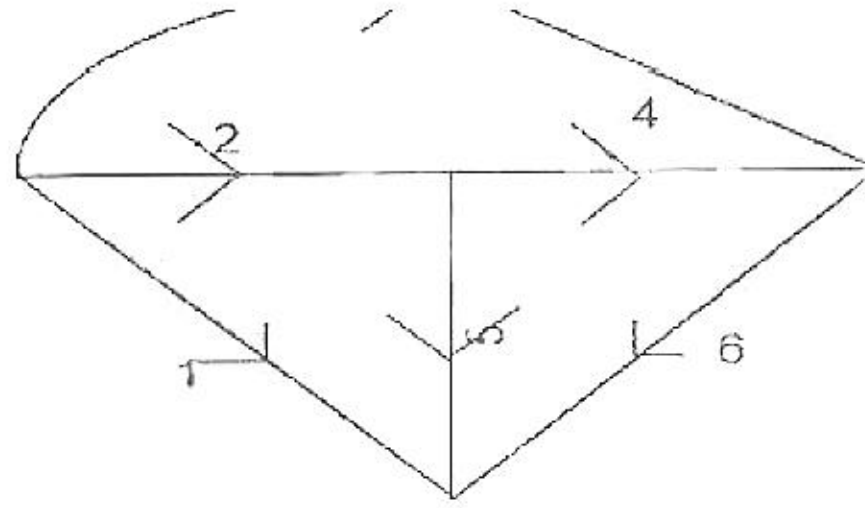

Options :

1. 1, 2, 3 and 4
2. 2, 3, 4 and 6
3. 1, 4, 5 and 6
4. 1, 3, 4 and 5

Question Number : 18 Question Id : 871112498 Display Question Number : Yes Single Line Question Option : No Option Orientation : Vertical

What is the  $V_{th}$  in the circuit given below?

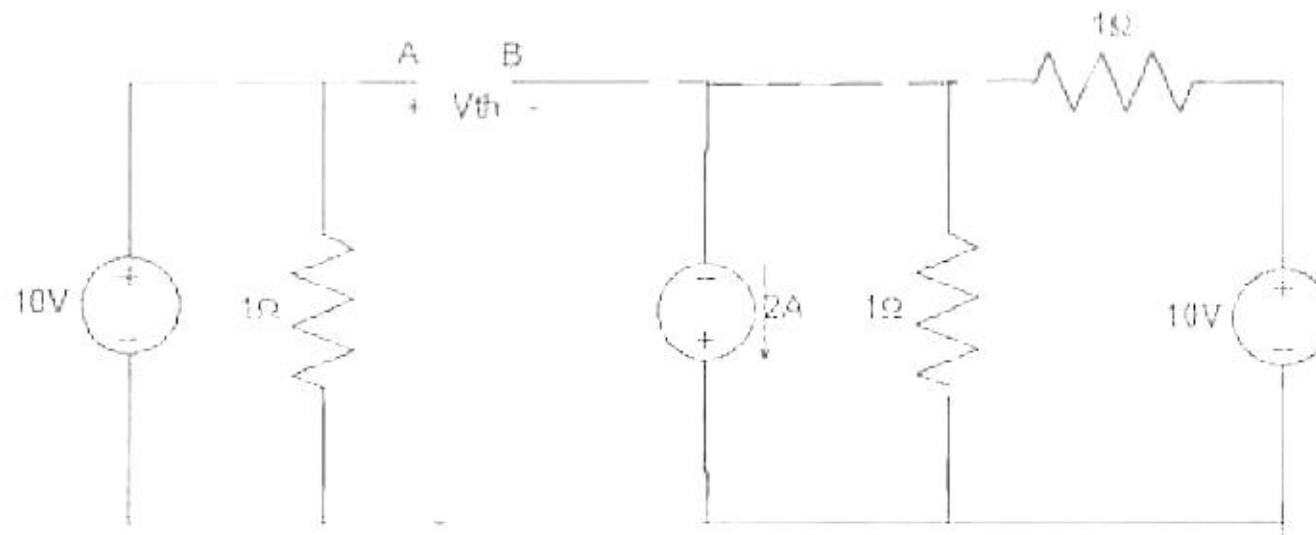

Options :

1. -14 V
2. -10 V
3. 14 V
4. 10 V

Question Number : 19 Question Id : 871112499 Display Question Number : Yes Single Line Question Option : No Option Orientation : Vertical



1. A & B unchanged, C is halved, B is double
2. A & B are doubled, C & D are unchanged
3. A, B, C and D are doubled
4. A & D unchanged, C is doubled, B is halved

Question Number : 20 Question Id : 871112500 Display Question Number : Yes Single Line Question Option : No Option Orientation : Vertical

Superposition theorem is applicable to networks containing

Options :

1. nonlinear elements
2. dependent current sources
3. dependent voltage sources
4. linear sources only

Question Number : 21 Question Id : 871112501 Display Question Number : Yes Single Line Question Option : No Option Orientation : Vertical

The voltage  $V$  in the following figure is always equal to

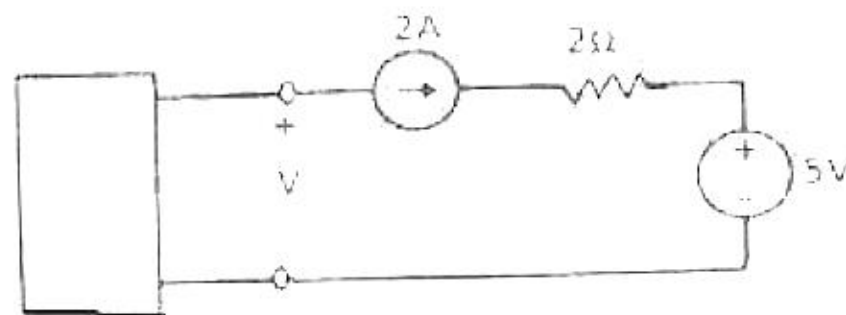

Options :

1. 9 V
2. 1 V
3. 7 V
4. zero

Three impedances  $Z_1 = 10 \angle 30^\circ \Omega$ ,  $Z_2 = 20 \angle 45^\circ \Omega$  and  $Z_3 = 30 \angle 60^\circ \Omega$  are connected in parallel. The rms currents are

Options :

1.  $2.887 \angle -30^\circ \text{ A}$ ,  $2.887 \angle -150^\circ \text{ A}$  and  $2.887 \angle 90^\circ \text{ A}$
2.  $5 \angle -30^\circ \text{ A}$ ,  $5 \angle -150^\circ \text{ A}$  and  $5 \angle 90^\circ \text{ A}$
3.  $2.887 \angle -30^\circ \text{ A}$ ,  $5 \angle 90^\circ \text{ A}$  and  $2.887 \angle -150^\circ \text{ A}$
4.  $5 \angle 0^\circ \text{ A}$ ,  $5 \angle -120^\circ \text{ A}$  and  $5 \angle 120^\circ \text{ A}$

Question Number : 23 Question Id : 871112503 Display Question Number : Yes Single Line Question Option : No Option Orientation : Vertical

What is the current through R2?

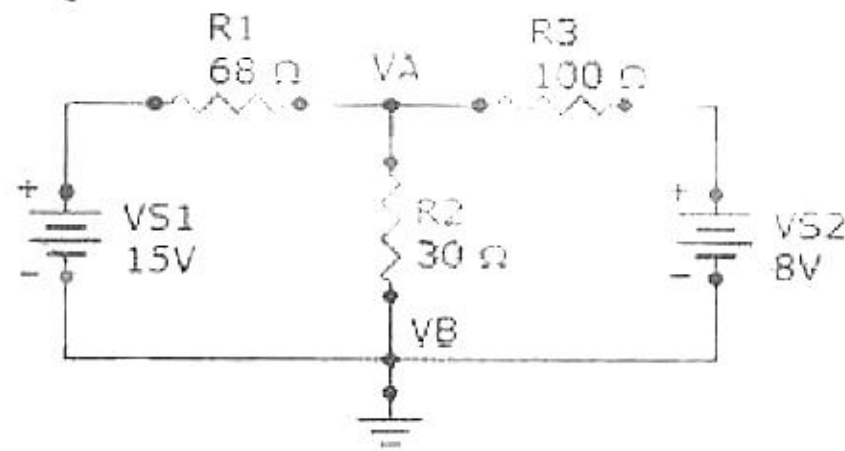

Options :

1. 173 mA
2. 3.19 A
3. 319 mA
4. 1.73 mA

Question Number : 24 Question Id : 871112504 Display Question Number : Yes Single Line Question Option : No Option Orientation : Vertical

What is the voltage  $V_x$  in the circuit shown below?

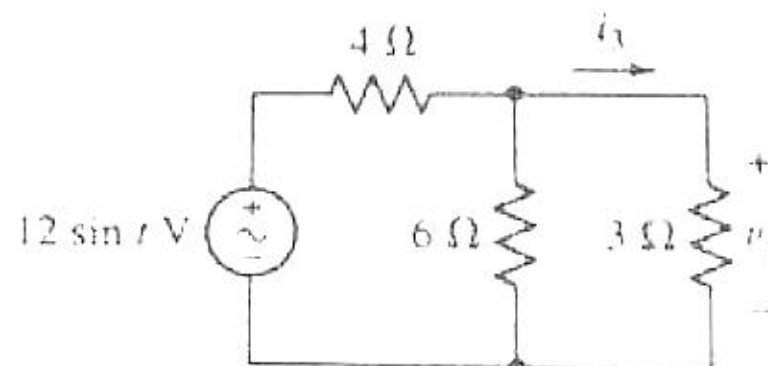

Options :

- 2.  $-4 \cos t$
- 3.  $2 \sin t$
- 4.  $-2 \cos t$

Question Number : 25 Question Id : 871112505 Display Question Number : Yes Single Line Question Option : No Option Orientation : Vertical

A series RLC circuit has a response frequency of 1 kHz and a quality factor  $Q = 400$ . If each R, L, and C are doubled from its original value, the new quality factor, Q of the circuit is

Options :

- 1. 25
- 2. 50
- 3. 100
- 4. 200

Question Number : 26 Question Id : 871112506 Display Question Number : Yes Single Line Question Option : No Option Orientation : Vertical

A function  $f(t)$  is said to have quarter wave symmetry if

Options :

- 1.  $f(t) = f(-t)$  only
- 2.  $f(t) = -f(-t)$  only
- 3.  $f(t) = -f\left(t \pm \frac{T}{2}\right)$  only
- 4.  $f(t) = f(-t)$  and  $f(t) = -f(-t)$

Question Number : 27 Question Id : 871112507 Display Question Number : Yes Single Line Question Option : No Option Orientation : Vertical

A moving average function is given by  $y(t) = \frac{1}{T} \int_{t-T}^t u(\tau) dt$ . If the input  $u$  is a sinusoidal signal of frequency  $\frac{1}{2T}$  Hz, then in steady state, the output  $y$  will lag  $u$  (in degree) by



2.  $70^\circ$
3.  $90^\circ$
4.  $80^\circ$

Question Number : 28 Question Id : 871112508 Display Question Number : Yes Single Line Question Option : No Option Orientation : Vertical

The unit impulse response of a system is given as  $e(t) = -4e^{-t} + 6e^{-2t}$ . The step response of the same system for  $t \geq 0$  is equal to

Options :

1.  $-3e^{-2t} + 4e^{-t} - 2$
2.  $-3e^{-2t} + 4e^{-t} + 1$
3.  $-3e^{-2t} + 4e^{-t} - 1$
4.  $-3e^{-2t} + 4e^{-t} - 1$

Question Number : 29 Question Id : 871112509 Display Question Number : Yes Single Line Question Option : No Option Orientation : Vertical

Given a sequence  $x[n]$ , to generate the sequence  $y[n] = x[3 - 4n]$ , which of the following steps in the listed order would be correct?

Options :

1. Delay by 3 samples, pick every 4<sup>th</sup> sample, time reverse
2. Advance by 3 samples, pick every 4<sup>th</sup> sample, time reverse
3. Pick every fourth sample, time-reverse, advance by 3 samples
4. Pick every fourth sample, time-reverse, delay by 3 samples

Question Number : 30 Question Id : 871112510 Display Question Number : Yes Single Line Question Option : No Option Orientation : Vertical



Options :

1. Even and odd
2. Real and imaginary
3. Discrete and continues
4. Periodic and aperiodic

Question Number : 31 Question Id : 871112511 Display Question Number : Yes Single Line Question Option : No Option Orientation : Vertical

In which of the following cases, a control system is unstable?

Options :

1. Gain margin and Phase margin are positive
2. Phase crossover frequency is less than Gain crossover frequency
3. Damping ratio is greater than zero
4. Phase crossover frequency greater than Gain crossover frequency

Question Number : 32 Question Id : 871112512 Display Question Number : Yes Single Line Question Option : No Option Orientation : Vertical

The unilateral Laplace transform of  $f(t)$  is  $\frac{1}{s^2+s+1}$ . The unilateral Laplace transform of  $tf(t)$  is

Options :

1.  $\frac{-s}{(s^2+s+1)^2}$
2.  $\frac{-2s-1}{(s^2+s+1)^2}$
3.  $\frac{s}{(s^2+s+1)^2}$
4.  $\frac{2s+1}{(s^2+s+1)^2}$

integers  $m$  and  $n$  so that  $x[n]$  may be expressed as  $x[n] = a[mn - n_0]$  and

Options :

1. 1, 2
2. -1, -3
3. 3, -1
4. 2, -2

Question Number : 34 Question Id : 871112514 Display Question Number : Yes Single Line Question Option : No Option Orientation : Vertical

The inverse Fourier transform of  $X(j\omega) = 2\pi\delta(\omega) + \pi\delta(\omega - 4\pi) + \pi\delta(\omega + 4\pi)$  is

Options :

1.  $\cos(4\pi t)$
2.  $\sin(4\pi t)$
3.  $1 - \sin(4\pi t)$
4.  $1 + \cos(4\pi t)$

Question Number : 35 Question Id : 871112515 Display Question Number : Yes Single Line Question Option : No Option Orientation : Vertical

The convolution of  $e^t u(t)$  and  $e^{-2t} u(t)$  is

Options :

1.  $(e^{-t} - e^{-2t})u(t)$
2.  $e^{-3t}u(t)$
3.  $e^t u(t)$
4.  $(e^{-t} + e^{-2t})u(t)$

Question Number : 36 Question Id : 871112516 Display Question Number : Yes Single Line Question Option : No Option Orientation : Vertical

1. series resistance
2. shunt inductance
3. series inductance
4. shunt resistance

Question Number : 37 Question Id : 871112517 Display Question Number : Yes Single Line Question Option : No Option Orientation : Vertical

The rotor power output of a 3-phase induction motor is 15 kW, the rotor copper losses at a slip of 4% will be

Options :

1. 600 W
2. 650 W
3. 625 W
4. 700 W

Question Number : 38 Question Id : 871112518 Display Question Number : Yes Single Line Question Option : No Option Orientation : Vertical

A separately excited DC generator supplies 150 A to a 145 V DC grid. The generator is running at 800 rpm. The armature resistance of the generator is  $0.1 \Omega$ . If the speed of the generator is increased to 1000 rpm, the current in amperes supplied by the generator to the DC grid is \_\_\_\_\_.

Options :

1. 167.5
2. 188.5
3. 187.5
4. 189.5



capacitor is connected in parallel to the motor to improve the power factor of the combination of motor and capacitor to 0.8 lagging. Assuming that the real and reactive power drawn by the motor remains same as before, the reactive power delivered by the capacitor in MVAR is

**Options :**

1. 7
2. 6
3. 8
4. 9

**Question Number : 40 Question Id : 871112520 Display Question Number : Yes Single Line Question Option : No Option Orientation : Vertical**

The effect of leakage flux in a transformer is to

**Options :**

1. increase copper losses
2. decrease copper losses
3. cause voltage drop in the windings
4. improve the efficiency

**Question Number : 41 Question Id : 871112521 Display Question Number : Yes Single Line Question Option : No Option Orientation : Vertical**

The purpose of connecting resistance in the rotor circuit of slip rings induction motor is

**Options :**

1. to increase running torque
2. to increase starting torque
3. to achieve maximum running torque



Question Number : 42 Question Id : 871112522 Display Question Number : Yes Single Line Question Option : No Option Orientation : Vertical

The efficiency of a transformer at full-load 0.8 pf lag is 94%. Its efficiency at full load 0.8 pf lead

Options :

1. is less than 94%
2. is more than 94%
3. is equal to 94%
4. cannot be evaluated

Question Number : 43 Question Id : 871112523 Display Question Number : Yes Single Line Question Option : No Option Orientation : Vertical

Let P and Q denote the active and reactive powers consumed from the grid by an induction machine. Given that the machine is operating as a generator, then P and Q are

Options :

1. both positive
2. both negative
3. positive and negative respectively
4. negative and positive respectively

Question Number : 44 Question Id : 871112524 Display Question Number : Yes Single Line Question Option : No Option Orientation : Vertical

The power input to a 400 V, 50 Hz, 6 pole, 3-phase induction motor running at 950 rpm is 38 kW. If the stator losses are 1 kW, and friction and windage losses are total 2 kW, the efficiency of the motor is

Options :

1. 85 %
2. 87.5 %
3. 92.1 %

Question Number : 45 Question Id : 871112525 Display Question Number : Yes Single Line Question Option : No Option Orientation : Vertical

The crawling in the induction motor is caused by

Options :

1. Improper design of the machine
2. Low voltage supply
3. Harmonics developed in the motor
4. Over load

Question Number : 46 Question Id : 871112526 Display Question Number : Yes Single Line Question Option : No Option Orientation : Vertical

The maximum electrical power input to synchronous motor is

Options :

1.  $X_s / V_t E_f$
2.  $E_f^2 / X_s$
3.  $V_t^2 / X_s$
4.  $E_f V_t / X_s$

Question Number : 47 Question Id : 871112527 Display Question Number : Yes Single Line Question Option : No Option Orientation : Vertical

Two transformers with leakage impedances  $Z_1 = 0.1 + j 0.4$  ohm and  $Z_2 = 0.05 + j 0.2$  ohm are connected in parallel. The ration of loads shared by them will be

Options :

1. Equal
2. 1/2
3. 2/1

Question Number : 48 Question Id : 871112528 Display Question Number : Yes Single Line Question Option : No Option Orientation : Vertical

A coil in a synchronous machine has a span of 132 degree. Which harmonic is completely eliminated from the coil voltage?

Options :

1. 7<sup>th</sup>
2. 5<sup>th</sup>
3. 3<sup>rd</sup>
4. 11<sup>th</sup>

Question Number : 49 Question Id : 871112529 Display Question Number : Yes Single Line Question Option : No Option Orientation : Vertical

Speed of a 3-phase synchronous generator is changed from 3000 to 1500 rpm. the generated e.m.f/phase will be

Options :

1. Doubled
2. Unchanged
3. Halved
4. One fourth

Question Number : 50 Question Id : 871112530 Display Question Number : Yes Single Line Question Option : No Option Orientation : Vertical

A 6-pole lap connected dc generator with 480 conductors has armature resistance of 0.06  $\Omega$ . If the conductors reconnected to form a wave winding keeping other things remaining unchanged. what is the value of the armature resistance?

Options :

1. 0.01
2. 0.06
3. 0.36



Question Number : 51 Question Id : 871112531 Display Question Number : Yes Single Line Question Option : No Option Orientation : Vertical

Lightening arrester is located nearer to

Options :

1. generator
2. bus- bar
3. circuit breaker
4. transformer

Question Number : 52 Question Id : 871112532 Display Question Number : Yes Single Line Question Option : No Option Orientation : Vertical

A loss-less transmission line with characteristic impedance of  $600 \Omega$  is terminated with a purely resistive load of  $900 \Omega$ . The reflection coefficient is

Options :

1. 0.2
2. 0.5
3. 1.5
4. 0.667

Question Number : 53 Question Id : 871112533 Display Question Number : Yes Single Line Question Option : No Option Orientation : Vertical

The per unit impedance of a circuit element is 0.15. If the base kV and base MVA are halved, then the new value of the per unit impedance of the circuit element will be

Options :

1. 0.075
2. 0.15
3. 0.30



Question Number : 54 Question Id : 871112534 Display Question Number : Yes Single Line Question Option : No Option Orientation : Vertical

A single phase 100 km long transmission line is loaded at 110 kV. If the loss in the line is 5 MW and the load is 150 MVA at 0.8 pf lag, then the resistance of the line is \_\_\_\_\_.

Options :

1. 2.933 ohms per phase
2. 3.666 ohms per phase
3. 2.1511 ohms per phase
4. 2.688 ohms per phase

Question Number : 55 Question Id : 871112535 Display Question Number : Yes Single Line Question Option : No Option Orientation : Vertical

A synchronous generator is synchronised to the grid and operating under normal conditions. Suddenly due to a fault, its excitation winding is open circuited. Then

Options :

1. it begins operating as an induction generator
2. the stator currents increase to high value
3. the stator voltages drop and it gradually stops
4. the speed becomes enormously high resulting in damage of the rotor

Question Number : 56 Question Id : 871112536 Display Question Number : Yes Single Line Question Option : No Option Orientation : Vertical

An RLC series circuit is predominantly inductive

Options :

1. at resonant frequency
2. below resonant frequency
3. above resonant frequency

Question Number : 57 Question Id : 871112537 Display Question Number : Yes Single Line Question Option : No Option Orientation : Vertical

The insulation resistance of a single core cable is  $150 \text{ M}\Omega/\text{km}$ . The insulation resistance for 3 km length is

Options :

1.  $25 \text{ M}\Omega$
2.  $50 \text{ M}\Omega$
3.  $150 \text{ M}\Omega$
4.  $450 \Omega$

Question Number : 58 Question Id : 871112538 Display Question Number : Yes Single Line Question Option : No Option Orientation : Vertical

A system having connected load of 50 kW, peak load of 30 kW, base load of 20 kW and average load of 15 kW, will have a load factor of

Options :

1. 80%
2. 60%
3. 50%
4. 30%

Question Number : 59 Question Id : 871112539 Display Question Number : Yes Single Line Question Option : No Option Orientation : Vertical

A power system consists of 300 buses out of which 20 buses are connected with generators, 25 buses are the ones with controlled reactive power support and 15 buses are the ones with fixed shunt capacitors. All other buses are load buses. It is proposed to perform a load flow analysis using Newton-Rapson method. The size of the Newton-Rapson Jacobian matrix is

Options :

1.  $553 \times 553$



3.

4.  $554 \times 554$

Question Number : 60 Question Id : 871112540 Display Question Number : Yes Single Line Question Option : No Option Orientation : Vertical

In a 100 bus power system, there are 10 generators. In a particular iteration of Newton-Raphson load flow technique (in polar coordinates), two of the PV buses are converted to PQ type. In this iteration,

Options :

1. the number of unknown voltage angles increases by two and the number of unknown voltage magnitudes increases by two.
2. the number of unknown voltage angles remain unchanged and the number of unknown voltage magnitudes increases by two
3. the number of unknown voltage angles increases by two and the number of unknown voltage magnitudes decreases by two
4. the number of unknown voltage angles remains unchanged and the number of unknown voltage magnitudes decreases by two

Question Number : 61 Question Id : 871112541 Display Question Number : Yes Single Line Question Option : No Option Orientation : Vertical

A single-phase, 2 kVA, 100/200 V transformer is reconnected as an auto-transformer such that its kVA rating is maximum. The new rating in kVA, is

Options :

1. 4
2. 6
3. 7
4. 8

Question Number : 62 Question Id : 871112542 Display Question Number : Yes Single Line Question Option : No Option Orientation : Vertical

In hydro power plants water hammer occurs in

Options :

2. PENSTOCK
3. Turbine casing
4. Draft tube

Question Number : 63 Question Id : 871112543 Display Question Number : Yes Single Line Question Option : No Option Orientation : Vertical

The steady state stability limit of a power system can be improved by

Options :

1. increasing the number of parallel lines between the transmission points
2. connecting capacitors in series with the line
3. reducing the excitation of the machine
4. increasing number of parallel lines or connecting the capacitors in series with the line

Question Number : 64 Question Id : 871112544 Display Question Number : Yes Single Line Question Option : No Option Orientation : Vertical

Consider the following statements in connection with a power system network

- a. It is easier to construct the  $Y_{BUS}$  matrix as compared to  $Z_{BUS}$  matrix
- b.  $Z_{BUS}$  matrix is a full matrix and  $Y_{BUS}$  matrix is sparse

Which statement is true?

Options :

1. 'a' only
2. 'b' only
3. Both a and b
4. Neither a nor b

Question Number : 65 Question Id : 871112545 Display Question Number : Yes Single Line Question Option : No Option Orientation : Vertical



Options :

1. Bus voltage and angle
2. Real power and Reactive power
3. Real power and bus voltage
4. Reactive power and bus voltage

Question Number : 66 Question Id : 871112546 Display Question Number : Yes Single Line Question Option : No Option Orientation : Vertical

Consider a unity feedback control system with open loop transfer function

$G(S) = \frac{K}{s(s+1)}$ , then the steady state error of the system due to unit step input is

Options :

1. 0
2. K
3. 1/K
4. infinity

Question Number : 67 Question Id : 871112547 Display Question Number : Yes Single Line Question Option : No Option Orientation : Vertical

With the introduction of derivative error compensation, the damping and settling times are respectively

Options :

1. decrease and decrease
2. increase and decrease
3. decrease and increase
4. increase and increase

The position and velocity error coefficients for a system of transfer

function  $G(s) = \frac{50}{(1+0.1s)(1+2s)}$  are \_\_\_\_\_ .

Options :

1. 0 and 0 respectively
2. 0 and infinity respectively
3. 50 and 0 respectively
4. 50 and infinity respectively

Question Number : 69 Question Id : 871112549 Display Question Number : Yes Single Line Question Option : No Option Orientation : Vertical

Consider the following statements regarding time domain analysis of a control system.

- (a) derivative control improves system's transient performance
- (b) Integral control does not improve system's steady state performance
- (c) Integral control can convert a second order system into third order system.

Of these statements

Options :

1. (a) and (b) are correct
2. (a) and (c) are correct
3. (b) and (c) are correct
4. (a), (b) and (c) are correct

Question Number : 70 Question Id : 871112550 Display Question Number : Yes Single Line Question Option : No Option Orientation : Vertical

The Nyquist plot of a loop transfer function  $G(j\omega)H(j\omega)$  of a system encloses the  $(-1, j0)$  point, then the gain margin of the system is

Options :

1. less than zero
2. equal to zero

4. infinity

Question Number : 71 Question Id : 871112551 Display Question Number : Yes Single Line Question Option : No Option Orientation : Vertical

In order to improve the stability of a system, the correct sequence of steps to be taken are

Options :

1. insert derivative action, use negative feedback, reduce gain
2. reduce gain, use negative feedback, insert derivative action
3. reduce gain, insert derivative action, use negative feedback
4. use negative feedback, reduce gain, insert derivative action

Question Number : 72 Question Id : 871112552 Display Question Number : Yes Single Line Question Option : No Option Orientation : Vertical

The root locus for open loop transfer function  $G(s)H(s) = \frac{k(s+6)}{(s+3)(s+5)}$ . The break away and break in points are located respectively at

Options :

1. -2 and -1
2. -2.47 and -3.77
3. -4.27 and -7.23
4. -7.73 and -4.27

Question Number : 73 Question Id : 871112553 Display Question Number : Yes Single Line Question Option : No Option Orientation : Vertical

The value of A matrix in  $\dot{x} = Ax$  for the system described by the differential equation  $\ddot{y} + 4\dot{y} - 3y = 0$ , is

Options :

1.  $\begin{bmatrix} 1 & 0 \\ -4 & -1 \end{bmatrix}$



3.  $\begin{bmatrix} 0 & 1 \\ -3 & 4 \end{bmatrix}$

4.  $\begin{bmatrix} 0 & 1 \\ 3 & -4 \end{bmatrix}$

Question Number : 74 Question Id : 871112554 Display Question Number : Yes Single Line Question Option : No Option Orientation : Vertical

The number of roots of  $s^3 + 5s^2 + 7s + 3 = 0$  in the right half of the s-plane are

Options :

- 1. 0
- 2. 1
- 3. 2
- 4. 3

Question Number : 75 Question Id : 871112555 Display Question Number : Yes Single Line Question Option : No Option Orientation : Vertical

Bode asymptotes plot is shown here. The transfer function contains

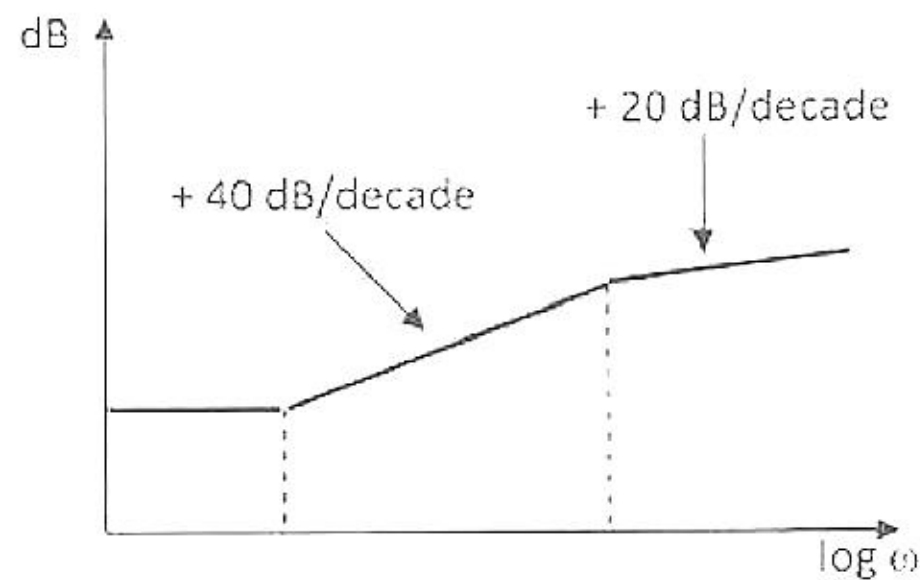

Options :

- 1. Two poles and one zero
- 2. Two zeros and one pole
- 3. Two poles and two zeros

Question Number : 76 Question Id : 871112556 Display Question Number : Yes Single Line Question Option : No Option Orientation : Vertical

The Nyquist plot of a unity feedback system having open loop transfer function of  $\frac{(s+2)}{(s+1)(s-3)}$  has one CCW encirclement of  $-1+j0$  point. The feedback system is

Options :

1. Stable
2. Unstable
3. Marginally stable
4. Highly stable

Question Number : 77 Question Id : 871112557 Display Question Number : Yes Single Line Question Option : No Option Orientation : Vertical

For a system given as  $\dot{X} = \begin{bmatrix} 0 & 1 \\ -1 & -1 \end{bmatrix} X + \begin{bmatrix} 0 \\ 1 \end{bmatrix} r$ ,  $C = [1 \ 1]$  the controllability and observability are

Options :

1. Uncontrollable and unobservable
2. Controllable and unobservable
3. Uncontrollable and observable
4. Controllable and observable

Question Number : 78 Question Id : 871112558 Display Question Number : Yes Single Line Question Option : No Option Orientation : Vertical

A transfer function  $\frac{1+0.5s}{1+s}$  represents a

Options :

1. Lead network controller

LAG LEAD NETWORK

3.

PI

4.

Question Number : 79 Question Id : 871112559 Display Question Number : Yes Single Line Question Option : No Option Orientation : Vertical

Which of the following compensators will increase the bandwidth of a given control system

Options :

Phase lag network

1.

Phase lead network

2.

Phase lag-lead network

3.

Phase lag and Phase lead in cascade

4.

Question Number : 80 Question Id : 871112560 Display Question Number : Yes Single Line Question Option : No Option Orientation : Vertical

Consider a linear time-invariant system transfer function  $H(s) = \frac{1}{(s+1)}$ . If the input is  $\cos(t)$  and the steady state output is  $A \cos(t + \alpha)$  then the value of A is

Options :

0.707

1.

1.1414

2.

2

3.

0.5

4.

Question Number : 81 Question Id : 871112561 Display Question Number : Yes Single Line Question Option : No Option Orientation : Vertical

While measuring power of a three-phase balanced load by the two-wattmeter method, the readings are 100 W and 250 W. The power factor of the load is \_\_\_\_\_.

Options :

0.6

1.



3.

0.802

4.

Question Number : 82 Question Id : 871112562 Display Question Number : Yes Single Line Question Option : No Option Orientation : Vertical

Q-meter works on the principle of

Options :

mutual inductance

1.

self inductance

2.

series resonance

3.

parallel resonance

4.

Question Number : 83 Question Id : 871112563 Display Question Number : Yes Single Line Question Option : No Option Orientation : Vertical

Which of the following is used to measure the leakage resistance of a capacitor?

Options :

Megger

1.

Schering bridge

2.

Kelvin's double bridge

3.

loss of charge method

4.

Question Number : 84 Question Id : 871112564 Display Question Number : Yes Single Line Question Option : No Option Orientation : Vertical

In a digital voltmeter over ranging implies that

Options :

single digit switched on

1.

single digit switched on

3.

1/2 digit switched off

4.

Question Number : 85 Question Id : 871112565 Display Question Number : Yes Single Line Question Option : No Option Orientation : Vertical

In a ramp type digital voltmeter if the oscillator frequency is 400 kHz and the ramp voltage falls from 8 V to 0 V in 20 milliseconds. the number of pulses counted by the counter is

Options :

1. 20

2. 160

3. 3.200

4. 8.000

Question Number : 86 Question Id : 871112566 Display Question Number : Yes Single Line Question Option : No Option Orientation : Vertical

A circle is found on the screen of a CRO when two time-varying signals of same frequency and same magnitude are applied to X and Y plates of the CRO. What is the relative phase difference?

Options :

1.  $0^\circ$

2.  $90^\circ$

3.  $180^\circ$

4.  $45^\circ$

Question Number : 87 Question Id : 871112567 Display Question Number : Yes Single Line Question Option : No Option Orientation : Vertical

Which of the following instruments will have poorest overloading capacity?

Options :

1. Moving coil type

3.

Hotwire type

4.

Question Number : 88 Question Id : 871112568 Display Question Number : Yes Single Line Question Option : No Option Orientation : Vertical

Kelvin's double bridge is used to measure low resistances because

Options :

1. it has high sensitivity
2. there is no thermoelectric emf
3. resistance variation due to temperature
4. effect of contact and lead resistances are eliminated

Question Number : 89 Question Id : 871112569 Display Question Number : Yes Single Line Question Option : No Option Orientation : Vertical

Which of the following is used to eliminate the effect of earth capacitance from the bridge network?

Options :

1. Wagner's earthing device
2. High voltage at low frequency
3. Low voltage at high frequency
4. Campbell-Maxwell device

Question Number : 90 Question Id : 871112570 Display Question Number : Yes Single Line Question Option : No Option Orientation : Vertical

Dead time of the instrument is

Options :

1. the time required by an instrument to begin to respond to a change in the measurand



3. the largest change of input quantity for which there is no output of the instrument.
4. the off time of the instrument

Question Number : 91 Question Id : 871112571 Display Question Number : Yes Single Line Question Option : No Option Orientation : Vertical

The voltage gain of the circuit shown in the figure below is given by

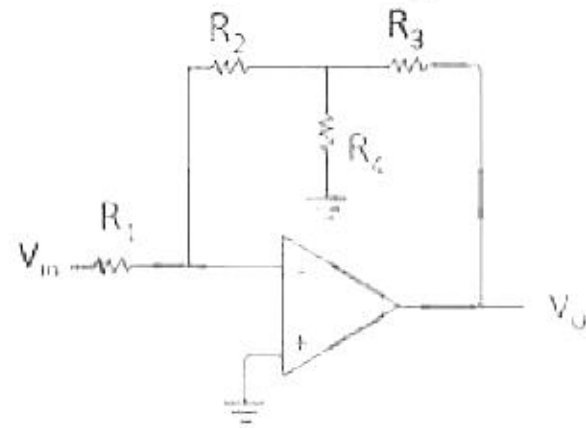

Options :

1.  $-\left[\frac{R_2 + R_3 + (R_2 R_3) / R_4}{R_1}\right]$
2.  $-\left[\frac{((R_3 R_4) / (R_3 + R_4) + R_2)}{R_1}\right]$
3.  $-\left[\frac{((R_2 R_4) / (R_2 + R_4) + R_3)}{R_1}\right]$
4.  $-\left[\frac{R_2 + R_3}{R_1}\right]$

Question Number : 92 Question Id : 871112572 Display Question Number : Yes Single Line Question Option : No Option Orientation : Vertical

The boolean expression for output of XNOR logic gate with inputs A and B is

Options :

1.  $\bar{A} B + A \bar{B}$
2.  $\bar{A} \bar{B} + AB$
3.  $(\bar{A} + B (A + B))$
4.  $(\bar{A} + \bar{B} (A + B))$

Question Number : 93 Question Id : 871112573 Display Question Number : Yes Single Line Question Option : No Option Orientation : Vertical

Options :

1. equal on both the regions
2. more on N-side and less on P-side
3. less on N-side and more on P-side
4. less on both the regions

Question Number : 94 Question Id : 871112574 Display Question Number : Yes Single Line Question Option : No Option Orientation : Vertical

An operational amplifier has a unity gain bandwidth of 1 MHz. If the closed loop gain is 10, then the bandwidth of the closed loop amplifier is

Options :

1. 0.1 MHz
2. 10.0 MHz
3. -0.1 MHz
4. -10.0 MHz

Question Number : 95 Question Id : 871112575 Display Question Number : Yes Single Line Question Option : No Option Orientation : Vertical

Schmitt trigger converts

Options :

1. square wave to triangular Wave
2. square wave to sine wave
3. sine wave to square wave
4. sine wave to triangular wave

Question Number : 96 Question Id : 871112576 Display Question Number : Yes Single Line Question Option : No Option Orientation : Vertical

1. Voltage Controlled Voltage Source
2. Voltage Controlled Current source
3. Current Controlled Current source
4. Current Controlled Voltage Source

Question Number : 97 Question Id : 871112577 Display Question Number : Yes Single Line Question Option : No Option Orientation : Vertical

For a 4-bit ADC full scale voltage is 5V. What is the resolution?

Options :

1. 33.3%
2. 43.3%
3. 53.3%
4. 100%

Question Number : 98 Question Id : 871112578 Display Question Number : Yes Single Line Question Option : No Option Orientation : Vertical

For 8085 microprocessor, the following program is executed

```
MVI A, 05H
MVI B, 05H
PTR: ADD B;
DCR B;
JNZ PTR;
ADI 03H;
HLT;
```

At the end of program, accumulator contains

Options :

1. 17H
2. 20H
3. 23H



Question Number : 99 Question Id : 871112579 Display Question Number : Yes Single Line Question Option : No Option Orientation : Vertical

Which of these is the memory element used in a clocked sequential circuit?

Options :

1. Flip-flop
2. Gate
3. Static RAM
4. ROM

Question Number : 100 Question Id : 871112580 Display Question Number : Yes Single Line Question Option : No Option Orientation : Vertical

Among the four characteristics given below, which are the major requirements for an instrumentation amplifier?

- P: High common mode rejection ratio
- Q: High input impedance
- R: High linearity
- S: High output impedance

Options :

1. P, Q and R only
2. P and R only
3. P, Q and S only
4. Q, R and S only

Question Number : 101 Question Id : 871112581 Display Question Number : Yes Single Line Question Option : No Option Orientation : Vertical

An 8-bit DAC has  $V_{ref} = 5$  V, the output voltage when  $D = 10110100$  and  $V_{LSB}$  respectively are

Options :

1. 0.703 V, 29.5 mV

4.7 V, 2 mV

3.

4.7 V, 19.5 mV

4.

Question Number : 102 Question Id : 871112582 Display Question Number : Yes Single Line Question Option : No Option Orientation : Vertical

The timing difference between a slow memory and fast processor can be resolved if

Options :

processor is capable of waiting

1.

external buffer is used

2.

processor capable of waiting or external buffer

3.

neither processor capable of waiting or external buffer

4.

Question Number : 103 Question Id : 871112583 Display Question Number : Yes Single Line Question Option : No Option Orientation : Vertical

In order to realize an inclusive OR-gate the number of NAND and NOR gates required respectively will be

Options :

2, 3

1.

3, 2

2.

4, 5

3.

5, 4

4.

Question Number : 104 Question Id : 871112584 Display Question Number : Yes Single Line Question Option : No Option Orientation : Vertical

If a JK flip-flop is clocked at 10 kHz while  $J = 1$  and  $K = 1$ , what will be its output frequency?

Options :

0 kHz

1.

3.

4. 20 kHz

Question Number : 105 Question Id : 871112585 Display Question Number : Yes Single Line Question Option : No Option Orientation : Vertical

For a 3-input logic circuit shown below, the output Z can be expressed as

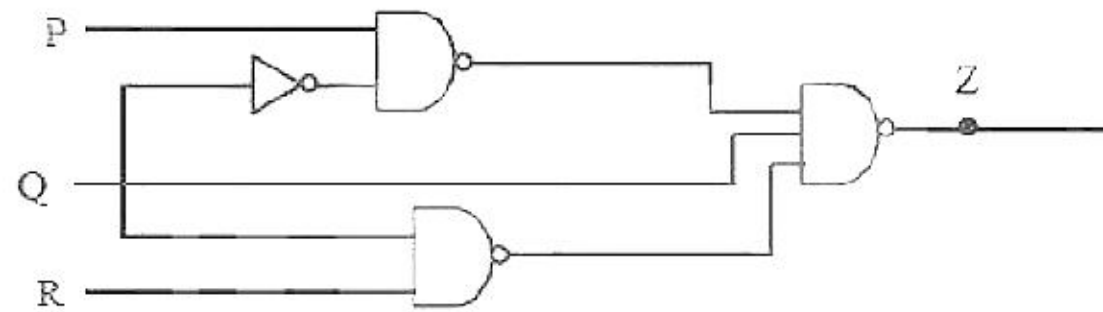

Options :

1.  $Q - \bar{R}$

2.  $P\bar{Q} - R$

3.  $\bar{Q} + R$

4.  $P + \bar{Q} + R$

Question Number : 106 Question Id : 871112586 Display Question Number : Yes Single Line Question Option : No Option Orientation : Vertical

The scheme of commutation in step up cyclo-converter is

Options :

1. Line Commutation

2. Natural Commutation

3. Forced commutation

4. Complementary commutation

Question Number : 107 Question Id : 871112587 Display Question Number : Yes Single Line Question Option : No Option Orientation : Vertical



load current at an on/off ratio of 1/1?

Options :

1. 10 A
2. 15 A
3. 20 A
4. 25 A

Question Number : 108 Question Id : 871112588 Display Question Number : Yes Single Line Question Option : No Option Orientation : Vertical

A self-commutating switch SW, operated at duty cycle  $\delta$  is used to control the load voltage as shown in the figure. Under steady state operating conditions, the average voltage across the inductor and the capacitor respectively, are

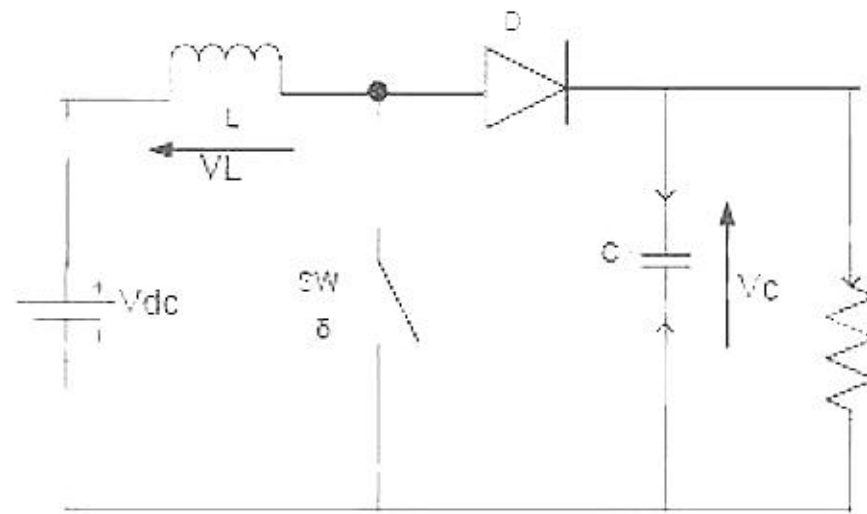

Options :

1.  $V_L = 0$  and  $V_c = \frac{1}{1-\delta} V_{dc}$
2.  $V_L = \frac{\delta}{2} V_{dc}$  and  $V_c = \frac{1}{1-\delta} V_{dc}$
3.  $V_L = 0$  and  $V_c = \frac{\delta}{1-\delta} V_{dc}$
4.  $V_L = \frac{\delta}{2} V_{dc}$  and  $V_c = \frac{\delta}{1-\delta} V_{dc}$

Question Number : 109 Question Id : 871112589 Display Question Number : Yes Single Line Question Option : No Option Orientation : Vertical

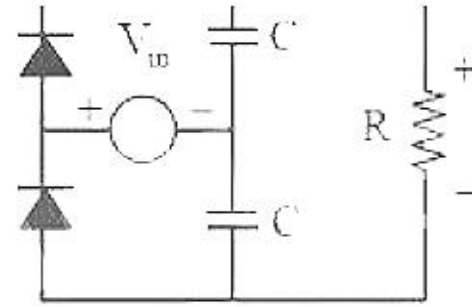

Options :

1. 100
2. 31.8
3. 200
4. 63.6

Question Number : 110 Question Id : 871112590 Display Question Number : Yes Single Line Question Option : No Option Orientation : Vertical

Material used for core of magnetic components in switching power converters is

Options :

1. Ferrite
2. Silicon steel
3. Alnico
4. NdFeB

Question Number : 111 Question Id : 871112591 Display Question Number : Yes Single Line Question Option : No Option Orientation : Vertical

In closed loop control of DC drives, current loop and speed loops are

Options :

1. outer and inner loops respectively
2. both in one loop
3. inner and outer loops respectively

Question Number : 112 Question Id : 871112592 Display Question Number : Yes Single Line Question Option : No Option Orientation : Vertical

Which of the following is a non-linear application of an OPAMP?

Options :

1. Adder
2. Integrator
3. Comparator
4. Logarithmic amplifier

Question Number : 113 Question Id : 871112593 Display Question Number : Yes Single Line Question Option : No Option Orientation : Vertical

In which configuration a dead band condition occurs in Schmitt trigger?

Options :

1. Comparator with negative feedback
2. Voltage follower with negative feedback
3. Voltage follower with positive feedback
4. Comparator with positive feedback

Question Number : 114 Question Id : 871112594 Display Question Number : Yes Single Line Question Option : No Option Orientation : Vertical

A half wave thyristor converter supplies a pure inductive load. If the triggering angle of the thyristor is  $120^\circ$ , the extinction angle will be

Options :

1.  $240^\circ$
2.  $180^\circ$
3.  $200^\circ$
4.  $120^\circ$



the load. For the firing angle of 60 degrees for the SCR, the average output voltage is

Options :

1.  $200/\pi$  V
2.  $150/\pi$  V
3.  $120/\pi$  V
4.  $100/\pi$  V

Question Number : 116 Question Id : 871112596 Display Question Number : Yes Single Line Question Option : No Option Orientation : Vertical

What are the constituents in speed time curve of train?

Options :

1. Initial acceleration
2. Constant speed
3. Coasting
4. Initial acceleration, constant speed, coasting and retardation

Question Number : 117 Question Id : 871112597 Display Question Number : Yes Single Line Question Option : No Option Orientation : Vertical

A schedule speed of 36 kmph is required between two stops of 1.5 km apart. The duration of stops is 25 seconds. The retardation is 3 kmphs. Calculate the maximum speed if the ratio of maximum speed to average speed is 1.25. (Assume simplified trapezoidal curve)

Options :

1. 90 km per hour
2. 74 km per hour
3. 54 km per hour
4. 40 km per hour

**Options :**

1. Average speed
2. Schedule speed
3. Notching speed
4. Free running speed

**Question Number : 119 Question Id : 871112599 Display Question Number : Yes Single Line Question Option : No Option Orientation : Vertical**

For a given run and scheduled speed, the specific energy consumption is

**Options :**

1. lower, the higher the acceleration and retardation
2. higher, the lower the acceleration and retardation
3. higher, the higher the acceleration and retardation
4. lower, the lower the acceleration and retardation

**Question Number : 120 Question Id : 871112600 Display Question Number : Yes Single Line Question Option : No Option Orientation : Vertical**

Series motor is not suited for traction duty due to which of the following account?

**Options :**

1. Less current drain on the heavy load torque
2. Current surges after temporary switching off supply
3. Self-relieving property
4. Commutating property at heavy load