

# GATE : 1997

## EE : Electrical Engineering

Duration : Three Hours

Maximum Marks : 150

### SECTION -A (MARKS = 100)

- EE.1. This question has 25 statements. Each statement is accompanied by four answers of which only one is correct. Indicate the correct answer as A, B, C and D on the first page of the answer book. Each statement carries one mark. (25 × 1 = 25)
- 1.1 An ideal voltage source will charge an ideal capacitor  
(a) in infinite time (b) exponentially  
(c) instantaneously (d) none of these
- 1.2 A practical current source is usually represented by  
(a) a resistance in series with an ideal current source  
(b) a resistance in parallel with an ideal current source  
(c) a resistance in parallel with an ideal voltage source  
(d) none of the above
- 1.3 In a uniform electric field, field lines and equipotentials  
(a) are parallel to one another  
(b) intersect at 45°  
(c) intersect at 30°  
(d) are orthogonal
- 1.4 Energy stored in a capacitor over a cycle, when excited by an a.c. source is  
(a) the same as that due to a d.c. source of equivalent magnitude  
(b) half of that due to a d.c. source of equivalent magnitude  
(c) zero  
(d) none of the above
- 1.5 A dynamometer type wattmeter responds to the  
(a) average value of active power  
(b) average value of reactive power  
(c) peak value of active power  
(d) peak value of reactive power
- 1.6 A transfer instrument employed in the standardization of a polar type a.c. potentiometer is  
(a) an electrostatic instrument  
(b) a thermal instrument  
(c) a dynamometer instrument  
(d) a moving coil instrument
- 1.7 In a LVDT, the two secondary voltages  
(a) are independent of the core position  
(b) vary unequally depending on the core position  
(c) vary equally depending on the core position  
(d) are always in the phase quadrature
- 1.8 The primary current in a current transformer is dictated by  
(a) the secondary burden  
(b) the core of the transformer  
(c) the load current  
(d) none of the above
- 1.9 A major advantage of active filters is that they can be realized without using  
(a) op-amps (b) inductors  
(c) resistors (d) capacitors
- 1.10 If a diode is connected in anti-parallel with a thyristor, then  
(a) both turn-off power loss and turn-off time decrease  
(b) turn-off power loss decreases but turn-off time increases  
(c) turn-off power loss increases, but turn-off time decreases  
(d) none of the above
- 1.11 In a dual converter, the circulating current  
(a) allows smooth reversal of load current, but increases the response time  
(b) does not allow smooth reversal of load current, but reduces the response time  
(c) allows smooth reversal of load current with improved speed of response  
(d) flows only if there is no interconnecting inductor



- 1.12 In a microprocessor, the address of the next instruction to be executed, is stored in  
 (a) stack pointer  
 (b) address latch  
 (c) program counter  
 (d) general purpose register
- 1.13 The computer program which converts statements written in high level language to object code is known as  
 (a) assembler  
 (b) operating system  
 (c) object-oriented software  
 (d) none of these
- 1.14 A differentiator has transfer function whose  
 (a) phase increases linearly with frequency  
 (b) amplitude remains constant  
 (c) amplitude increases linearly with frequency  
 (d) amplitude decreases linearly with frequency
- 1.15 Introduction of integral action in the forward path of a unity feedback system results in a  
 (a) marginally stable system  
 (b) system with no steady state error  
 (c) system with increased stability margin  
 (d) system with better speed of response
- 1.16 A square matrix is called singular, if its  
 (a) determinant is unity  
 (b) determinant is zero  
 (c) determinant is infinity  
 (d) rank is unity
- 1.17 Gauss-Seidel iterative method can be used for solving a set of  
 (a) linear differential equations only  
 (b) linear algebraic equations only  
 (c) both linear and nonlinear algebraic equations  
 (d) both linear and nonlinear differential equations
- 1.18 If an induction machine is run at above synchronous speed, it acts as  
 (a) a synchronous motor  
 (b) an induction generator  
 (c) an inductor motor  
 (d) none of these
- 1.19 The low voltage winding of a 400/230V, 1-phase, 50 Hz transformer is to be connected to a 25 Hz supply at 25 Hz, the supply voltage should be  
 (a) 230 V  
 (b) 460 V  
 (c) 115 V  
 (d) 65 V
- 1.20 A voltage  $v = 400 \sin 314.16 t$  is applied to a 1-phase transformer on no-load. If the no load current of the transformer is  $2 \sin (314.16 t - 85^\circ)$ , then magnetization branch impedance will be approximately equal to  
 (a)  $141 \angle 90^\circ$   
 (b)  $200 \angle -85^\circ$   
 (c)  $200 \angle 85^\circ$   
 (d)  $282 \angle -80^\circ$
- 1.21 For a fault at the terminals of a synchronous generator, the fault current is maximum for a  
 (a) 3-phase fault  
 (b) 3-phase to ground fault  
 (c) line-to-ground fault  
 (d) line-to-line fault
- 1.22 Reactance relay is normally preferred for protection against  
 (a) earth faults  
 (b) phase faults  
 (c) open-circuit faults  
 (d) none of these
- 1.23 A 100 MVA, 11 kV, 3-phase, 50 Hz, 8-pole synchronous generator has an inertia constant  $H$  equal to 4 seconds. The stored energy in the rotor of the generator at synchronous speed will be  $H = \frac{E}{G}$   
 (a) 100 MJ  
 (b) 400 MJ  
 (c) 800 MJ  
 (d) 12.5 MJ
- 1.24 The use of high-speed circuit-breakers  
 (a) reduces the short circuit current  
 (b) improves system stability  
 (c) decreases system stability  
 (d) increases the short circuit current
- 1.25 Bundled conductors are employed to improve the  
 (a) appearance of the transmission line  
 (b) mechanical stability of the line  
 (c) decreases system stability  
 (d) increases the short circuit current
- EE.2. This question consists of 25 statements with blanks. Fill in the blanks with the correct answer. Each question carries Two marks. (25 × 2 = 50)
- 2.1 For the two port network shown in Figure, the admittance matrix is ....

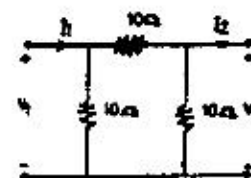

- 2.2 For the circuit shown in Figure. The Norton equivalent source current value is ... A and its resistance is .... Ohms

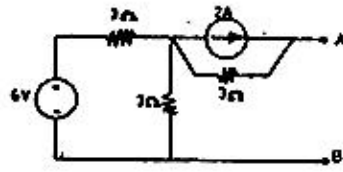

- 2.3 A 10 V battery with an internal resistance of  $1\Omega$  is connected across a nonlinear load whose V-I characteristic is given by  $7I = V^2 + 2V$ . The current delivered by the battery is ... A.
- 2.4 The values of E and I for the circuit shown in Figure, are ... V and ... A.

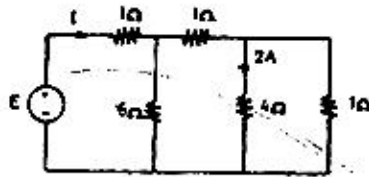

- 2.5 The voltage and current waveforms for an element are shown in Figure. The circuit element is ... and its value is ...

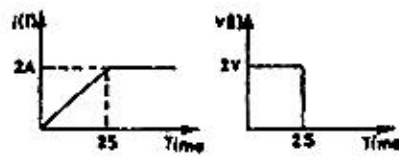

- 2.6 The capacitance of the arrangement shown in Figure, is ... pF

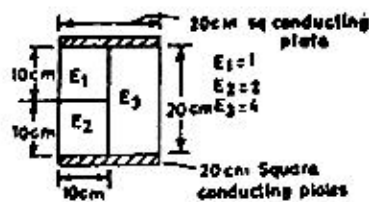

- 2.7 Two identical coils of negligible resistance when connected in series across a 200 V, 50 Hz source draws, a current of 10 A. When the terminals of one of the coils are reversed, then current drawn is 8 A. The coefficient of coupling between the two coils is .....

- 2.8 The capacitance of an isolated sphere of radius 10 cm in air is equal to .... pF

- 2.9 In the circuit shown in Figure, for measuring resistance 'R' if the ammeter indicates 1 A and the voltmeter indicates 100 V, then the value of R is ... Ohms and the error in measurement using the ratio  $V/I$  is .... %

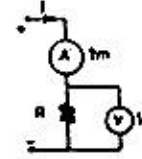

- 2.10 For the circuit shown in Figure, the wattmeter reading will be ... W and the power dissipated in the load is ... W.

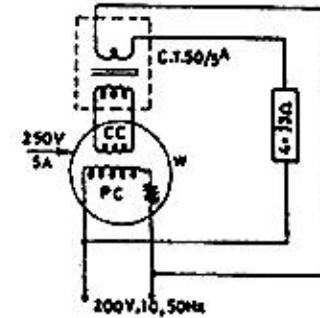

- 2.11 In the capacitor divider arrangement shown in Figure, for measurement of high voltages, the minimum resistance of the voltmeter for 1% error is ... Ohms and the voltage reading will be ... V

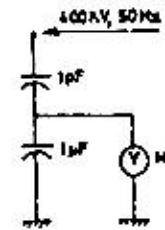

- 2.12 The circuit shown in Figure, acts as a ... and for the given inputs, its output voltage is ... V

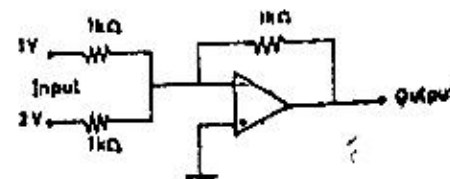

- 2.13 For an input signal of  $4 \sin 10t$ , the voltage across the resistance  $R$  in the circuit shown in figure, is .... V.

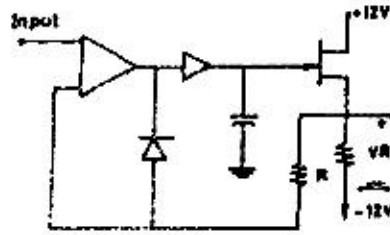

- 2.14 The range of addresses for which the memory chip shown in Figure, will be selected is ... to ...

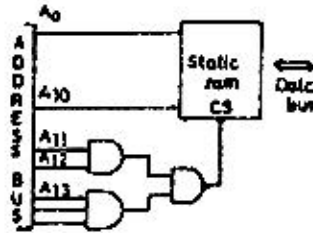

- 2.15 The system represented by the transfer function

$$G(s) = \frac{s^2 + 10s + 24}{s^4 + 6s^3 - 39s^2 + 19s + 84} \text{ has ... pole (s)}$$

in the right-half  $s$ -plane.

- 2.16 A unity feedback system with the open loop

$$\text{transfer function } G(s) = \frac{1}{s(s+2)(s+4)} \text{ has gain}$$

margin of ... dB.

- 2.17 A 5 kW, 2000 V d.c. shunt motor has an armature resistance of 1 ohm and shunt field resistance of 100 ohms. At no-load, the motor draws 6A from a 200 V supply and runs at 1000 rpm. The rotational loss of the machine is ... W and the no load torque is .... N-m

- 2.18 A 200 V, 10 kW lap-wound d.c. generator has 10 poles and 500 conductors on its armature. If the pole face covers 80% of the pole pitch, the pole face conductors required to fully compensate for armature reaction will be ... conductors/pole.

- 2.19 A 3-phase, 20 kW, 400 V, 1470 rpm, 50 Hz squirrel cage induction motor develops a torque of 100 N-m at a speed of 1400 rpm. If the motor is connected to a 30Hz supply, for keeping the same air-gap flux, then supply voltage should be ... V and for the same load torque, the new speed will be ... rpm.

- 2.20 The field coil of a two-pole d.c. series motor is made up of two identical sections. In one case (i) of two sections of the field coil are connected in series, and in another case (ii) the two sections are connected in parallel. If the motor takes the rated current in both the cases, then torque (i) : torque (ii) is ... and speed (i) : speed (ii) is ... (Neglect the effect of magnetic saturation)

- 2.21 The velocity of propagation of electromagnetic wave on an underground cable with relative permittivity of 3 will be .... m/sec.

- 2.23 The synchronous reactance of a 200 MVA, 10 kV, 3-phase, 50 Hz generator is 1.0 p.u. at its own base. Its p.u. reactance at 100 MVA, 20 kV base will be ...

- 2.24 A single-phase alternator has a synchronous reactance of 2 ohms and negligible resistance. If it supplies 10 A to a purely capacitive load at 200 V, then generated e.m.f will be ... V and the regulation will be ... %

- 2.25 A 3-phase transformer bank consists of three identical 2300/230 V, 15 kVA single-phase transformers connect in delta/delta. The bank supplies a 20 kV A, unity p.f. 3-phase load. If one of the single-phase transformer develops a fault, and is removed, the load carried by each of the two transformers now operating in open delta will be ... kVA.

3. Compute the amplitude of the fundamental component of the waveform given in figure.

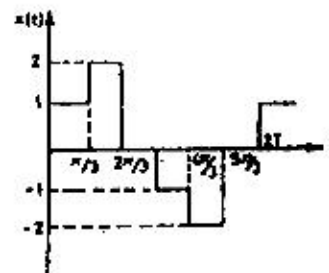

4. Determine the electric field intensity at the point P for the arrangement shown in Figure, above..

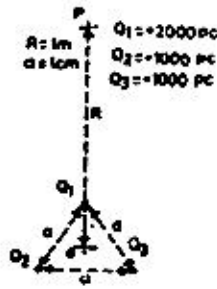

5. Determine whether the system given by the block diagram of Figure, is stable.

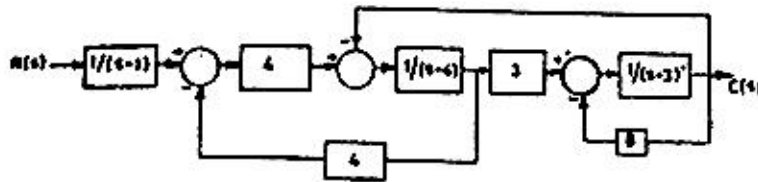

6. The system shown in Figure feeds two loads—  
 (a) a factory load of 15 MVA consisting of induction motors and  
 (b) a domestic load of 10 MW at 0.8 p.f. lagging at 6 kV. If the induction motors are rated at 6 kV and take 5 times their rated current at zero p.f. at starting, calculate the dip in voltage at the domestic load bus bar when all the induction motors are started at the same time

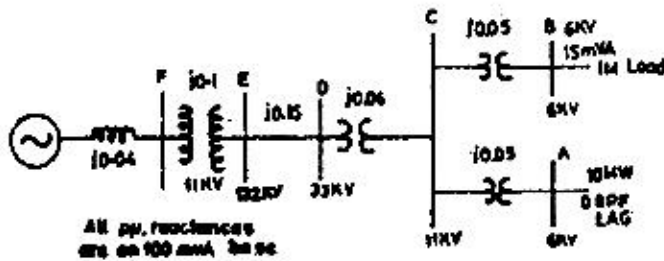

7. For the differential amplifier circuit shown in Figure, determine the differential gain, the common-mode gain and the common mode rejection ratio.

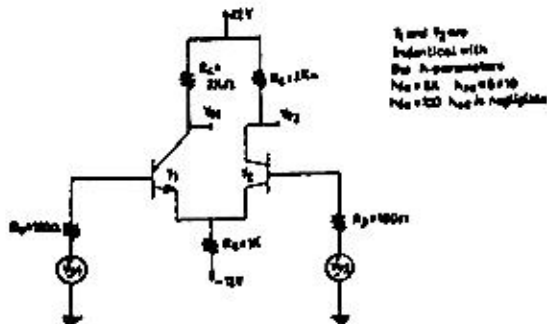

Answer any TEN questions from this section. Each question carries 5 Marks.

8. Find the Thevenin equivalent about AB for the circuit shown in Figure.

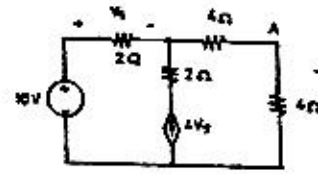

9. In the circuit shown in Figure.  $e_g(t) = 2.5 t$  volts. What are the values of  $i(t)$  and  $V_L(t)$  at  $t = 4$  seconds?

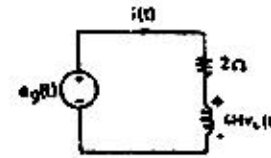

10. Given Figure shows a magnetic circuit formed by an ideal core material. Determine the magnetic flux density in the air gap.

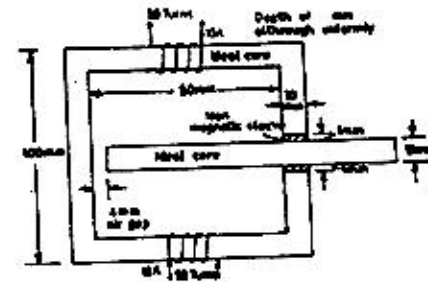

11. A infinitely long straight wire carries 1000 A of current and in the vicinity there is a circular conducting loop of 100 mm diameter with the centre of the loop 1m away from the straight conductor. Both the wire and the loop are coplanar. Determine the magnitude and direction of current in the loop that produces a zero flux density at its centre.

12. A square coil of turns and 100 cm side is moved through a steady magnetic field of  $1 \text{ Wb/m}^2$  at a constant velocity of 2 m/sec with its plane perpendicular to the field as shown in Figure. Plot the variation of induced e.m.f as the coil moves along the field.

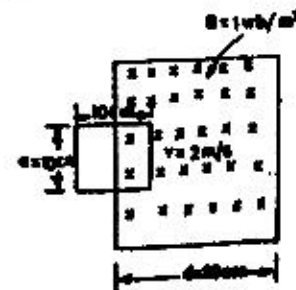

13. A 0–1000 micro ampere microammeter guaranteed to be 0.1% accurate needs to be calibrated using a 1.0 V d.c. potentiometer. Draw the circuit diagram and find the value of the standard resistance used and the least count of the potentiometer.

14. An SCR is connected in series with a 300 V ac supply and a 300 ohms load resistor. Calculate for a firing angle of  $45^\circ$ ,

- (a) the reading of a moving coil ammeter connected in series with the load, and  
 (b) the reading on a moving iron voltmeter connected across the SCR

15. A 3-input 2-output priority encoder has the following truth table where x-s indicate don't care conditions. Realize the logic using NAND gates and inverters.

$W_2$	$W_1$	$W_0$	$Y_1$	$Y_0$
0	0	0	0	0
0	0	1	0	0
0	1	X	1	0
1	X	X	1	1

16. Determine the frequency of oscillation of the circuit shown in Figure. Assume the op-amp to be ideal.

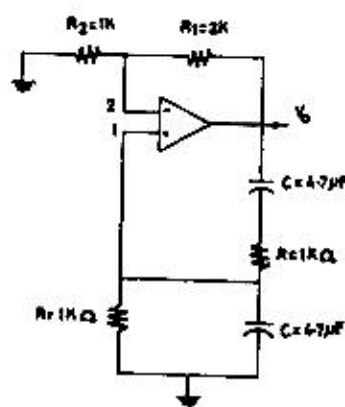

17. A first order system is initially at rest and excited by a step input at time  $t = 0$ . Its output becomes 1.1 V in 4 seconds and eventually reaches a steady state value of 2 V. Determine its time constant.

18. Determine the transfer function of the system having the following state variable representation :

$$\dot{X} = \begin{bmatrix} 0 & 1 & 0 \\ 0 & 0 & 1 \\ -40 & -44 & -14 \end{bmatrix} X + \begin{bmatrix} 0 \\ 1 \\ 0 \end{bmatrix} u$$

$$Y = [0 \ 1 \ 0] X$$

19. Express the given matrix A as a product of two triangular matrices, L and U, where the diagonal elements of the lower triangular matrix L are unity and U is an upper triangular matrix

$$A = \begin{bmatrix} 2 & 1 & 5 \\ 4 & 8 & 13 \\ 6 & 27 & 31 \end{bmatrix}$$

20. A system governed by the differential equation

$$\frac{d^2y}{dt^2} = 400 e^{-t} \text{ is initially at rest.}$$

Determine the value of  $y$  at  $t = 0.1$ s using the trapezoidal rule of integration with a step size of 0.05 s.

21. A synchronous motor is receiving 50% of the power. It is capable of receiving from an infinite bus. If the load on the motor is suddenly reduced to 80% of the previous value, swing of the motor around its new equilibrium position.

22. Two power systems A and B each having a regulation (R) of 0.05 p.u. of their respective capacity bases and a stiffness (damping coefficient) of 0.75 p.u. are connected through a tie-line, initially carrying no power. The capacity of system A is 2000 MW and that of system B is 3000 MW. If there is an increase in load of 200 MW in system A, what is the change in the steady state and power transfer.

23. A factory draws 100 kW at 0.7 p.f lagging from a 3-phase, 11 kV supply. It is desired to raise the p.f. to 0.95 lagging using series capacitors. Calculate the rating of the capacitor required.

24. A 50 kV A, 400 V, 3-phase, 50 Hz squirrel cage induction motor has full load slip of 5%. Its standstill impedance is 0.866 ohms/phase. It is started using a tapped autotransformer. If the maximum allowable supply current at the time of starting is 1000A, then calculate the tap position and the ratio of starting torque to full load torque.



25. At 50% of full load, the armature current drawn by a d.c. shunt motor is 40 A when connected to a 200 V d.c. mains. By decreasing the field flux, its speed is raised by 20% this also causes a 10% increase in load torque. Calculate the percentage change in field current. The armature resistance including the brushes is 1 Ohm. Neglect saturation and armature reaction.
26. A single-phase bridge inverter is fed from a 200 V d.c. supply and is operated at 50 Hz. It is connected to a load having a resistance of 20 ohms and an inductance of 0.2 H. Draw the load current waveform in the steady indicating the peak values.
27. A separately excited d.c. motor is fed from a chopper operating at 500 Hz with a duty cycle of 50% and is drawing an average current of 10 A from a 200 V d.c. source. A field wheeling diode is connected across it. The motor has negligible armature resistance, a field inductance of 50 mh and a torque constant of 0.5 N-m/A. Determine the minimum and maximum motor current, motor back e.m.f. and the mechanical torque developed.

## ANSWERS

### SECTION – A

- |          |          |          |          |          |          |          |          |          |          |
|----------|----------|----------|----------|----------|----------|----------|----------|----------|----------|
| 1.1 (c)  | 1.2 (b)  | 1.3 (d)  | 1.4 (c)  | 1.5 (a)  | 1.6 (b)  | 1.7 (b)  | 1.8 (c)  | 1.9 (b)  | 1.10 (b) |
| 1.11 (c) | 1.12 (c) | 1.13 (d) | 1.14 (c) | 1.15 (b) | 1.16 (b) | 1.17 (b) | 1.18 (b) | 1.19 (c) | 1.20 (c) |
| 1.21(c)  | 1.22 (c) | 1.23 (c) | 1.24 (c) | 1.25 (c) |          |          |          |          |          |

