

VERSION CODE	Maximum Marks : 100 Total Duration : 150 Minutes Maximum Time For Answering : 120 Minutes Subject : <b>CHEMICAL ENGINEERING</b>
<b>A1</b>	MENTION YOUR PG CET NUMBER

Serial Number : **102057**

Subject Code	<b>P-CHE</b>
--------------	--------------

**DOs:**

1. This question booklet is issued to you by the invigilator after 02.20 pm.
2. Check whether the PG CET Number has been entered and shaded in the respective circles on the OMR answer sheet.
3. The version code and serial number of this question booklet should be entered on the OMR answer sheet and the respective circles should also be shaded completely.
4. The Version Code and Serial Number of this question booklet should be entered on the Nominal Roll without any mistakes.
5. Compulsorily sign at the bottom portion of the OMR answer sheet in the space provided.

**DON'Ts:**

1. The timing and marks printed on the OMR answer sheet should not be damaged / mutilated / spoiled.
2. The 3<sup>rd</sup> Bell rings at 2.30 p.m., till then;
  - Do not remove the seal present on the right hand side of this question booklet.
  - Do not look inside this question booklet or start answering on the OMR answer sheet.

**IMPORTANT INSTRUCTIONS TO CANDIDATES**

1. In case of usage of signs and symbols in the questions, the regular textbook connotation should be considered unless stated otherwise.
2. This question booklet contains 75 questions and each question will have one statement and four different options / responses & out of which you have to choose one correct answer.
3. After the 3<sup>rd</sup> Bell is rung at 02.30 pm, remove the paper seal on the right hand side of this question booklet and check that this booklet does not have any unprinted or torn or missing pages or items etc., if so, get it replaced by a complete test booklet. Read each item and start answering on the OMR answer sheet.
4. Completely darken / shade the relevant circle with a blue or black ink ballpoint pen against the question number on the OMR answer sheet.

ಸರಿಯಾದ ಕ್ರಮ CORRECT METHOD	ತಪ್ಪು ಕ್ರಮಗಳು WRONG METHOD
<input type="radio"/> A <input checked="" type="radio"/> B <input type="radio"/> C <input type="radio"/> D	<input checked="" type="radio"/> A <input type="radio"/> B <input type="radio"/> C <input type="radio"/> D <input type="radio"/> A <input type="radio"/> B <input type="radio"/> C <input checked="" type="radio"/> D <input type="radio"/> A <input checked="" type="radio"/> B <input checked="" type="radio"/> C <input type="radio"/> D
<input type="radio"/> A <input checked="" type="radio"/> B <input type="radio"/> C <input type="radio"/> D	<input checked="" type="radio"/> A <input type="radio"/> B <input type="radio"/> C <input type="radio"/> D <input type="radio"/> A <input checked="" type="radio"/> B <input type="radio"/> C <input type="radio"/> D

5. Please note that even a minute unintended ink dot on the OMR answer sheet will also be recognized and recorded by the scanner. Therefore, avoid multiple markings of any kind on the OMR answer sheet.
6. Use the space provided on each page of the question booklet for Rough Work. Do not use the OMR answer sheet for the same.
7. Last bell will ring at 4.30 pm, stop marking on the OMR answer sheet.
8. Hand over the OMR answer sheet to the room invigilator as it is.
9. After separating the top sheet (KEA copy), the invigilator will return the bottom sheet replica (candidate's copy) to you to carry home for self-evaluation.
10. Only Non-programmable calculators are allowed for "M.E. / M.Tech / M.Arch." examination.

<b>Marks</b>	<b>PART-1 : 50 QUESTIONS CARRY ONE MARK EACH (1 TO 50)</b>
<b>Distribution</b>	<b>PART-2: 25 QUESTIONS CARRY TWO MARKS EACH (51 TO 75)</b>



105027

PAGE



## CHEMICAL ENGINEERING

### PART – 1

Each question carries one mark.

(50 × 1 = 50)

1. Material balance equation can be applied to
  - (A) Total mass
  - (B) Mass of a component
  - (C) Moles of a component
  - (D) All of the mentioned.
2. A system in which the temperature is invariant during a process is
  - (A) Adiabatic system
  - (B) Isobaric system
  - (C) isochoric system
  - (D) Isothermal system
3. Zero per cent relative saturation means
  - (A) 100% vapour in the air
  - (B) 75% vapour in the air
  - (C) 50% vapour in the air
  - (D) No vapour in the air
4. The temperature reaches equilibrium for the vaporization of a small amount of water into a large amount of air:
  - (A) Dry bulb temperature
  - (B) Wet bulb temperature
  - (C) Standard temperature
  - (D) None of the mentioned
5. What is the percentage of excess air if 50 grams of air is in excess and 150 grams of air enters the process?
  - (A) 10%
  - (B) 25%
  - (C) 50%
  - (D) 100%
6. Water flows through a pipe at a velocity 2 m/s. The pressure gauge reading is 2 bar. The datum head is given to be 2 m. Find the piezometric head. (Assume all Bernoulli's assumptions, Density of water = 1000 kg/m<sup>3</sup>, g = 9.8 m/s<sup>2</sup>.)
  - (A) 22.4 m
  - (B) 22.6 m
  - (C) 20.4 m
  - (D) 20.6 m

---

Space For Rough Work



7. Which of the following is the dimension of kinematic viscosity?
- (A)  $[L^1 T^{-1}]$   
 (B)  $[L^1 T^{-2}]$   
 (C)  $[L^2 T^{-1}]$   
 (D)  $[L^2 T^{-2}]$
8. For any non-spherical particle, Sphericity is defined as
- (A)  $6V_p/D_p\rho_s$   
 (B)  $6V_p/\rho_s S_p$   
 (C)  $V_p/D_p S_p$   
 (D)  $6V_p/D_p S_p$
9. Following Rittinger's law, crushing efficiency is
- (A) Independent of feed material  
 (B) Independent of size of feed and product  
 (C) Independent of energy consumed  
 (D) Independent of area
10. What is the power required to crush 100 ton/h of limestone if 80 per cent of the feed passes a 2-in. screen and 80 percent of the product a 1/8 – in. screen? The work index of limestone is 12.74.
- (A) 181.96 kW  
 (B) 169.6 kW  
 (C) 144.54 kW  
 (D) 100 kW
11. Which of the following works on the principle of compression?
- (A) Knife cutter  
 (B) Blake jaw crusher  
 (C) Gyratory Crusher  
 (D) Rod Mill
12. In thorough washing, the wash liquid is introduced through alternate plates called \_\_\_\_\_
- (A) Bleeding plates  
 (B) Raking plates  
 (C) Washing plates  
 (D) Doctor's plate

---

Space For Rough Work



13. \_\_\_\_\_ is defined as the ratio of void containing wetting fluid and voids of both fluids.

- (A) Residual saturation
- (B) Effective saturation
- (C) Special saturation
- (D) Saturation

14. The mass balance for a fluid with density ( $\rho$ ) and velocity vector ( $\bar{V}$ ) is

- (A)  $\frac{\partial \rho}{\partial t} + \nabla \cdot (\rho \bar{V}) = 0$
- (B)  $\frac{\partial \rho}{\partial t} + \bar{V} \cdot (\nabla \rho) = 0$
- (C)  $\frac{\partial \rho}{\partial t} + \rho (\nabla \cdot \bar{V}) = 0$
- (D)  $\frac{\partial \rho}{\partial t} - \bar{V} \cdot (\nabla \rho) = 0$

15. For a Newtonian fluid flowing in a circular pipe under steady state conditions in fully developed laminar flow, the Fanning friction factor is

- (A)  $0.046 \text{ Re}^{-0.2}$
- (B)  $0.0014 + \frac{0.125}{\text{Re}^{0.32}}$
- (C)  $\frac{16}{\text{Re}}$
- (D)  $\frac{24}{\text{Re}}$

16. In a pool boiling experiment, the following phenomena were observed:

- P. Natural convection
- Q. Film boiling
- R. Transition boiling
- S. Nucleate boiling

What was the CORRECT sequence of their occurrence?

- (A) P, Q, R, S
- (B) S, R, Q, P
- (C) Q, R, P, S
- (D) P, S, R, Q

17. What is critical thickness of insulation for a spherical insulator?

- (A)  $k/h$
- (B)  $2k/h$
- (C)  $4k/h$
- (D)  $h/k$

18. In a double pipe heat exchanger, in the inner side fluid enters at  $20^\circ\text{C}$  and leaves at  $45^\circ\text{C}$ . The annulus has steam condensing at 1 atm. What is the value of LMTD?

- (A)  $39.33^\circ\text{C}$
- (B)  $66.72^\circ\text{C}$
- (C)  $70.21^\circ\text{C}$
- (D)  $40.50^\circ\text{C}$

Space For Rough Work



19.  $(N_{Gr} \times N_{Pr})$  is called the \_\_\_\_\_ number.

- (A) Graetz
- (B) Rayleigh
- (C) Nusselt
- (D) Stanton

20. A graph between \_\_\_\_\_ is called Wilson plot.

- (A)  $(1/U)$  Vs.  $(1/v^{0.8})$
- (B)  $(1/v^{0.8})$  Vs.  $U$
- (C)  $v^{0.8}$  Vs.  $U$
- (D)  $(1/U)$  Vs.  $(1/v)$

21. Pick out the wrong statement.

- (A) A closed system does not permit exchange of mass with its surroundings but may permit exchange of energy.
- (B) An open system permits exchange of both mass and energy with its surroundings.
- (C) The term micro-state is used to characterize an individual, whereas macro-state is used to designate a group of micro-states with common characteristics.
- (D) None of the above.

22. A fluid existing at a temperature greater than  $T_c$  is said to be

- (A) supercritical
- (B) subcritical
- (C) critical
- (D) none of these

23. Entropy is

- (A) State function
- (B) Path function
- (C) Both state and path functions
- (D) None of these

24. Residual Gibbs energy is defined as

- (A) Difference between actual and the ideal-gas-state values of the Gibbs energy at the same temperature and pressure.
- (B) Difference between actual and the ideal-solution values of the Gibbs energy at the same temperature but different pressure.
- (C) Difference between actual and the ideal-gas-state values of the Gibbs energy at the different temperature and pressure.
- (D) None of these

---

Space For Rough Work



25. In BUBL P calculations,

- (A)  $\{x_i\}$  and T are given and  $\{y_i\}$  and P are estimated.
- (B)  $\{x_i\}$  and P are given and  $\{y_i\}$  and T are estimated.
- (C)  $\{y_i\}$  and T are given and  $\{x_i\}$  and P are estimated.
- (D) None of these.

26. At equilibrium state,

- (A)  $(dG^*)_{T,P} = 0$       (B)  $(G^*)_{T,P} = 0$
- (C)  $(dG^*)_{T,P} > 0$       (D)  $(dG^*)_{T,P} < 0$

27. Which of the following reactions is not accompanied by elimination of a byproduct molecule?

- (A) addition polymerization
- (B) condensation polymerization
- (C) both of the mentioned
- (D) none of the mentioned.

28. For an elementary reaction  $2A \xrightarrow{k_1} 2B$

- (A)  $-r_A = r_B = k_1 C_A^2$
- (B)  $-r_A = r_B = k_1 C_A$
- (C)  $-r_A = r_B = k_1$
- (D)  $-r_A = r_B = k_1 C_A^{1.5}$

29. A plot of  $\ln k$  vs.  $1/T$  is known as

- (A) Bode diagram
- (B) Arrhenius plot
- (C) Van't Hoff plot
- (D) None of these

30. For varying volume batch reactor

- (A)  $1 - X_A = \frac{1 - C_A / C_{A0}}{1 + \epsilon_A C_A / C_{A0}}$
- (B)  $X_A = \frac{1 - C_A / C_{A0}}{1 - \epsilon_A C_A / C_{A0}}$
- (C)  $X_A = \frac{1 + C_A / C_{A0}}{1 + \epsilon_A C_A / C_{A0}}$
- (D)  $X_A = \frac{1 - C_A / C_{A0}}{1 + \epsilon_A C_A / C_{A0}}$

31. For varying volume system and homogeneous zero-order reaction the rate equation is

- (A)  $1n \left( 1 - \frac{\Delta V}{\epsilon_A V_0} \right) = kt$
- (B)  $-1n \left( 1 + \frac{\Delta V}{\epsilon_A V_0} \right) = kt$
- (C)  $-1n \left( 1 - \frac{\Delta V}{\epsilon_A V_0} \right) = kt$
- (D)  $1n \left( 1 + \frac{\Delta V}{\epsilon_A V_0} \right) = kt$

Space For Rough Work



32. For a mixed flow reactor and second order reaction, the performance equation for  $\varepsilon_A = 0$  is

(A)  $k\tau = \frac{C_A - C_{A0}}{C_A^2}$

(B)  $k\tau = \frac{C_{A0} - C_A}{C_A^2}$

(C)  $k\tau = \frac{C_A - C_{A0}}{C_A}$

(D)  $\tau = \frac{C_A - C_{A0}}{C_A^2}$

33. For a plug flow reactor and for special case of constant density system, the performance equation is

(A)  $X_A = 1 - \frac{C_{A0}}{C_A}$       (B)  $X_A = 1 + \frac{C_A}{C_{A0}}$

(C)  $X_A = 1 - \frac{C_A}{C_{A0}}$       (D)  $X_A = 1 + \frac{C_{A0}}{C_A}$

34. The rate equation

$$\text{rate} = \frac{C_{Ag}}{1 + \frac{C_{Ag}}{K_g} + \frac{C_A}{K_s}}$$

for gas-solid reaction

occurring in presence of a non-porous catalyst, which of the following is appropriate?

- (A) the reaction is kinetically-controlled (surface-reaction controlling)
- (B) the reaction is controlled by mass transfer of reactant from the bulk gas phase to the catalyst surface.
- (C) both mass transfer and chemical reaction on the surface are important and they are steps in series.
- (D) both mass transfer and chemical reaction on the surface are important and they are steps in parallel

35. A first order reaction  $A \rightarrow B$  occurs in an isothermal porous catalyst pellets of spherical shape. If the concentration of A at the centre of the pellet is much less than at the external surface, the process is limited by

- (A) diffusion in the pellet
- (B) surface reaction
- (C) external mass transfer
- (D) adsorption and desorption

36. The exit age distribution of fluid leaving a vessel is used to know the

- (A) Activation energies of reaction
- (B) Reaction mechanism
- (C) Extent of non-ideal flow in the vessel
- (D) None of these

37. The temperature of tempering oil baths maintained at 400°C during heat treatment of steel is measured by a/an \_\_\_\_\_ thermocouple.

- (A) chromel-alumel
- (B) iron-constantan
- (C) platinum-platinum-rhodium
- (D) none of these

Space For Rough Work





38. The closed loop pole of a stable second order system could be

- (A) both real and negative
- (B) one real positive and the other real negative
- (C) complex conjugate with positive real parts
- (D) both real and positive

39. Response of a linear control system for a change in set point is called

- (A) frequency response
- (B) transient response
- (C) servo problem
- (D) regulator problem

40. The open loop transfer function of a control system is  $KR/(1 + TS)$ . This represents

- (A) A first order system
- (B) Dead time system
- (C) A first order time lag
- (D) A second order system

41. A stable system will be defined as one for which the output response is

- (A) bounded for all bounded inputs
- (B) unbounded for all bounded inputs
- (C) Both (A) and (B)
- (D) None of these

42. A control system has the transfer functions:

$$G_1 = 10 \frac{0.5s + 1}{s}$$

$$G_2 = \frac{1}{2s + 1}$$

$$H = 1$$

- (A) For the given case, system is unstable.
- (B) For the given case, system is stable.
- (C) For the given case, system is unbounded.
- (D) None of these.

43. Which of the following dust collection equipments is the least efficient for sub-micron particles?

- (A) Dust Catcher (gravity type)
- (B) Cyclone separator
- (C) Bag filter
- (D) Hollow wet scrubber

---

Space For Rough Work



44. Disinfection of water is done to destroy pathogenic bacteria and thus prevent water-borne diseases. Disinfection of water may be done by the use of
- (A) Ozone and iodine
  - (B) Chlorine or its compounds
  - (C) Ultraviolet light for irradiation of water
  - (D) All (A), (B) and (C).
45. High noise levels produced during operation of fans and compressors can be reduced by using
- (A) Mufflers (silencers)
  - (B) Acoustical absorbent
  - (C) Lagging of noisy duct
  - (D) None of these
46. The form of sulphur which is the most stable at ordinary temperature is
- (A) monoclinic
  - (B) plastic
  - (C) rhombic
  - (D) flowers of sulphur
47. Oleum gives fumes of
- (A)  $H_2SO_4$
  - (B)  $H_2O + SO_2$
  - (C)  $SO_2$
  - (D)  $SO_3$
48. Yield of tar from high temperature carbonization of dry coal is about
- (A) 3%
  - (B) 8%
  - (C) 20%
  - (D) None of these
49. For an air(A)-water vapour (B) mixture, the partial pressure of the air is 5 Pa and the total pressure of the system is 15 Pa. The absolute humidity in mass of air/mass of water vapour is
- (A) 0.805
  - (B) 0.311
  - (C) 0.705
  - (D) 0.411
50. In a lumped-parameter model
- (A) Spatial variations are ignored
  - (B) Spatial variations are considered
  - (C) Both (A) and (B)
  - (D) None of these

---

Space For Rough Work



PART - 2

Each question carries two marks.

(25 × 2 = 50)

51. An oil with a flow rate of 1000 kg/h is to be cooled using water in a double-pipe counter flow heat exchanger from a temperature of 70°C to 40°C. Water enters the exchanger at 25°C and leaves at 40°C. The specific heats of oil and water are 2 kJ kg<sup>-1</sup> K<sup>-1</sup> and 4.2 kJ kg<sup>-1</sup> K<sup>-1</sup> respectively. The overall heat transfer coefficient is 0.2 kW m<sup>-2</sup> K<sup>-1</sup>. The minimum heat exchanger area (in m<sup>2</sup>) required for this operation is \_\_\_\_\_.

- (A) 3.85                      (B) 3.00  
(C) 4.87                      (D) 20.21

52. The value of  $h$  in cylindrical pipe is about 5 W/m<sup>2</sup>K for the case of natural convection of gases and that the thermal conductivity of common insulating materials is 0.05 W/mK, the largest value of the critical radius is

- (A) 10 mm                      (B) 100 mm  
(C) 0.1 mm                      (D) 1 mm

53. The value of  $h$  is about 5 W/m<sup>2</sup>K in sphere containing gases and the thermal conductivity of common insulating materials is 0.05 W/mK, the largest value of the critical radius is

- (A) 20 mm                      (B) 200 mm  
(C) 0.2 mm                      (D) 2 mm

54. A triple effect evaporator is concentrating a liquid that has no appreciable elevation in boiling point. The temperature of the steam to the first effect is 108°C, the boiling point of the solution in the last effect is 52°C. The overall heat transfer coefficients, in W/m<sup>2</sup>·°C, are 2500 in the first effect, 2000 in the second effect and 1000 in third effect. At what temperature will the liquid boil in the first and second effects?

- (A) Boiling point in the first and second effects will be 96.2°C and 81.5°C respectively  
(B) Boiling point in the first and second effects will be 81.5°C and 96.2°C respectively  
(C) Boiling point in the first and second effects will be 106.2°C and 91.5°C respectively  
(D) Boiling point in the first and second effects will be 91.5°C and 106.2°C respectively

55. Volume expansivity is defined as

- (A)  $\beta \equiv \frac{1}{V} \left( \frac{\partial V}{\partial T} \right)_v$   
(B)  $\beta \equiv \frac{1}{V} \left( \frac{\partial V}{\partial T} \right)_p$   
(C)  $\beta \equiv \frac{1}{P} \left( \frac{\partial V}{\partial T} \right)_p$   
(D)  $\beta \equiv \frac{1}{P} \left( \frac{\partial V}{\partial T} \right)_v$

Space For Rough Work



56. Isothermal compressibility is defined as

(A)  $k \equiv -\frac{1}{V} \left( \frac{\partial V}{\partial P} \right)_T$

(B)  $k \equiv \frac{1}{V} \left( \frac{\partial V}{\partial P} \right)_T$

(C)  $k \equiv -\frac{1}{V} \left( \frac{\partial P}{\partial V} \right)_T$

(D)  $k \equiv -\frac{1}{V} \left( \frac{\partial V}{\partial P} \right)_P$

57. For liquid acetone at 20°C and 1 bar (with  $\beta = 1.487 \times 10^{-3} \text{C}^{-1}$ ,  $k = 62 \times 10^{-6} \text{bar}^{-1}$ ,  $V = 1.287 \text{ cm}^3 \cdot \text{g}^{-1}$ ), the value of  $(\partial P / \partial T)_V$  at 20°C and 1 bar is

(A) 241 bar°C<sup>-1</sup>

(B) 24 bar°C<sup>-1</sup>

(C) 1241 bar°C<sup>-1</sup>

(D) 10 bar°C<sup>-1</sup>

58. For ideal gas state

(A)  $\left( \frac{\partial V^{ig}}{\partial P} \right)_P = \frac{R}{P}$

(B)  $\left( \frac{\partial V^{ig}}{\partial T} \right)_P = \frac{R}{P}$

(C)  $\left( \frac{\partial P^{ig}}{\partial T} \right)_P = \frac{R}{P}$

(D) None of these

59. Which of the following is correct?

(A)  $\frac{G^R}{RT} = \int_0^P (Z-1) \frac{dV}{V}$  (constant T)

(B)  $\frac{G^R}{RT} = \int_0^P (Z-1) \frac{dT}{T}$  (constant P)

(C)  $\frac{G^R}{RT} = \int_0^T (Z-1) \frac{dT}{P}$  (constant V)

(D)  $\frac{G^R}{RT} = \int_0^P (Z-1) \frac{dP}{P}$  (constant T)

60. The chemical reaction occurs in a system initially consisting of 2 mol CH<sub>4</sub>, 1 mol H<sub>2</sub>O, 1 mol CO, and 4 mol H<sub>2</sub>.

CH<sub>4</sub> + H<sub>2</sub>O → CO + 3H<sub>2</sub>. The expression for the mole fractions  $y_{\text{CH}_4}$  as functions of  $\epsilon$  is

(A)  $y_{\text{CH}_4} = \frac{2 + \epsilon}{8 + 2\epsilon}$

(B)  $y_{\text{CH}_4} = \frac{2 - \epsilon}{8 + 2\epsilon}$

(C)  $y_{\text{CH}_4} = \frac{2 - \epsilon}{8 + \epsilon}$

(D)  $y_{\text{CH}_4} = \frac{2 - \epsilon}{8 - 2\epsilon}$

Space For Rough Work



61. The equilibrium constant at 298 K of the reaction  $\text{N}_2\text{O}_4(\text{g}) \rightarrow 2\text{NO}_2(\text{g})$  (given that the standard free energies of formation at 298 K are 97,540 J/mol for  $\text{N}_2\text{O}_4$  and 51,310 J/mol for  $\text{NO}_2$ ) is

- (A) 0.7811      (B) 7.8110  
(C) 0.1287      (D) 1.2870

62. For a certain gas phase reaction  $-\frac{dC_A}{dt} = kC_A^n$  the rate of reaction in terms of partial pressure may be expressed as

- (A)  $-\frac{dp_A}{dt} = kp_A^n$   
(B)  $-\frac{dp_A}{dt} = kRTp_A^n$   
(C)  $-\frac{dp_A}{dt} = k(RT)^{1-n}p_A^n$   
(D)  $-\frac{dp_A}{dt} = k(RT)^np_A^{1-n}$

63. When a reaction is conducted in a variable volume batch reactor, rate of reaction  $-r_A$ , is given by

- (A)  $-r_A = C_{A0} \varepsilon_A x_A \frac{dx_A}{dt}$   
(B)  $-r_A = \frac{C_{A0}}{\varepsilon_A x_A} \frac{dx_A}{dt}$   
(C)  $-r_A = \frac{\varepsilon_A}{C_{A0} x_A} \frac{dx_A}{dt}$   
(D)  $-r_A = \frac{C_{A0}}{1 + \varepsilon_A x_A} \frac{dx_A}{dt}$

64. For a certain reaction, the following plot is given. Which of the following rate expressions is correct?

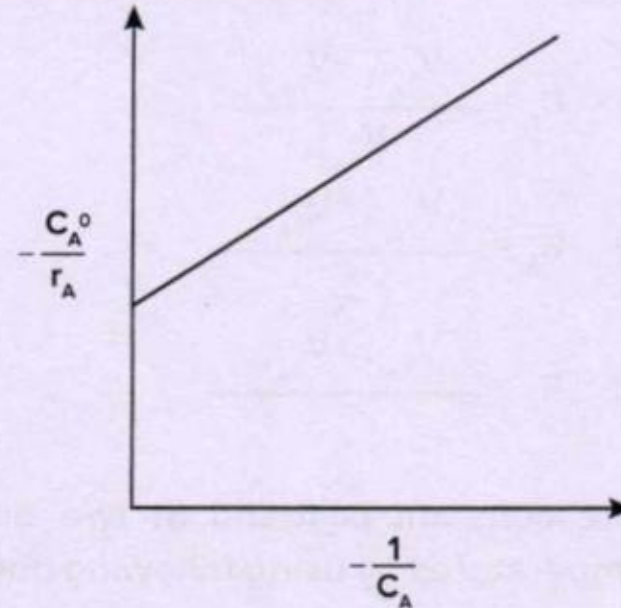

- (A)  $-r_A = k_1 C_A + k_2$   
(B)  $-r_A = \left( \frac{K_1 C_A}{1 + K_2 C_A} \right)$   
(C)  $-r_A = \frac{K_1 C_A^2}{1 + K_2 C_A}$   
(D)  $-r_A = \frac{K_1 C_A}{1 + K_2 C_A^2}$

65. The half life period of the reaction is given by

- (A)  $t_F = \sim \frac{F^{1-n}-1}{k(n-1)} C_{A0}^{1-n}$   
(B)  $t_F = \sim \frac{F^{1-n}-1}{k(n-1)} C_{A0}^{1-n}$   
(C)  $t_F = \sim \frac{F^{1-n}+1}{k(n-1)} C_{A0}^{1-n}$   
(D)  $t_F = \sim \frac{F^{1-n}-1}{k(n-1)} C_{A0}^{n+1}$

Space For Rough Work



66. For varying volume batch reactor

$$(A) \quad \epsilon_A = \frac{V_{x_A=1} - V_{x_A=0}}{V_{x_A=0}}$$

$$(B) \quad \epsilon_A = \frac{V_{x_A=1} - V_{x_A=0}}{V_{x_A=1}}$$

$$(C) \quad \epsilon_A = \frac{V_{x_A=1} + V_{x_A=0}}{V_{x_A=0}}$$

$$(D) \quad \epsilon_A = \frac{V_{x_A=1} + V_{x_A=0}}{V_{x_A=1}}$$

67. Rate constant is found at two different temperatures by using following equation:

$$(A) \quad \ln \frac{k_2}{k_1} = \frac{E}{R} \left[ \frac{1}{T_1} - \frac{1}{T_2} \right]$$

$$(B) \quad -\ln \frac{k_2}{k_1} = \frac{E}{R} \left[ \frac{1}{T_1} - \frac{1}{T_2} \right]$$

$$(C) \quad \ln \frac{k_2}{k_1} = \frac{E}{R} \left[ \frac{1}{T_1} + \frac{1}{T_2} \right]$$

$$(D) \quad -\ln \frac{k_2}{k_1} = \frac{E}{R} \left[ \frac{1}{T_1} + \frac{1}{T_2} \right]$$

68. If  $-r_A = -\left(\frac{dC_A}{dt}\right) = 0.2 \text{ mol/lit.sec}$ ,

when,  $C_A = 1 \text{ mol/lit}$ , what is the rate of reaction when  $C_A = 10 \text{ mol/lit}$ ?

- (A) 10 mol/lit.sec
- (B) 0.2 mol/lit.sec
- (C) 1 mol/lit.sec.
- (D) Not possible to estimate the rate of reaction.

69. Liquid A decomposes by first order kinetics and in a batch reactor 50% of A is converted in a 5-minutes run. How much longer would it take to reach 75% conversion?

- (A) 10 min
- (B) 15 min
- (C) 5 min
- (D) 20 min

70. In a homogeneous isothermal liquid polymerization, 20% of the monomer disappears in 34 minutes for initial monomer concentration of 0.04 and also for 0.8 mol/lit. What is the value of k for the disappearance of the monomer?

- (A)  $0.0657 \text{ min}^{-1}$
- (B)  $0.00657 \text{ min}^{-1}$
- (C)  $0.657 \text{ min}^{-1}$
- (D)  $6.57 \text{ min}^{-1}$

71. One litre/min of liquid containing a reactant A at a concentration of 0.2 mol/l flows into a continuously operated ideal flow stirred tank reactor. The outflow from the reactor contains A at a concentration of 0.02 mol/l. If the volume of the reactor is 2 lit, the rate of reaction of A realized in the reactor is

- (A)  $0.02 \text{ mol/1 min}$
- (B)  $0.09 \text{ mol/1 sec}$
- (C)  $0.09 \text{ mol/1 min}$
- (D)  $0.18 \text{ mol/1 min}$

Space For Rough Work

72. For a mixed flow reactor and first order reaction, the performance equation for any  $\varepsilon_A$  is

(A)  $k\tau = \frac{X_A(1 + \varepsilon_A X_A)}{1 + X_A}$

(B)  $k\tau = \frac{X_A(1 - \varepsilon_A X_A)}{1 - X_A}$

(C)  $\tau = \frac{X_A(1 + \varepsilon_A X_A)}{1 - X_A}$

(D)  $k\tau = \frac{X_A(1 + \varepsilon_A X_A)}{1 - X_A}$

73. The root locus plot of the roots of the characteristics equation of a closed loop system having the open loop transfer function  $K(s+1)/2(2s+1)(3s+1)$  will have a definite number of loci for variation of  $K$  from 0 to  $\infty$ . The number of loci is

(A) 1

(B) 3

(C) 4

(D) 2

74. An expression for  $C$  in terms of  $R$  and  $U_1$  for the situation when both set point change and load change occur simultaneously for the following is

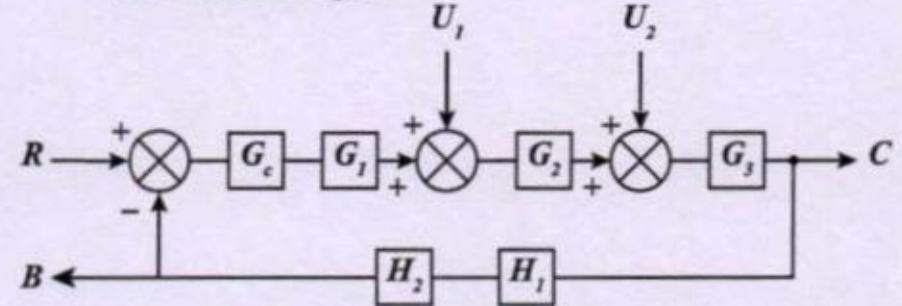

(A)  $C = \frac{G_c G_1 G_2 G_3}{1 + G} R$

(B)  $C = \frac{G_2 G_3}{1 + G} U_1$

(C)  $C = \frac{G_c G_1 G_2 G_3}{1 + G} R + \frac{G_2 G_3}{1 + G} U_1$

(D)  $C = \frac{G_c G_1 G_2 G_3}{1 + G} U_1 + \frac{G_2 G_3}{1 + G} R$

75. Find the point P in this enriching section:

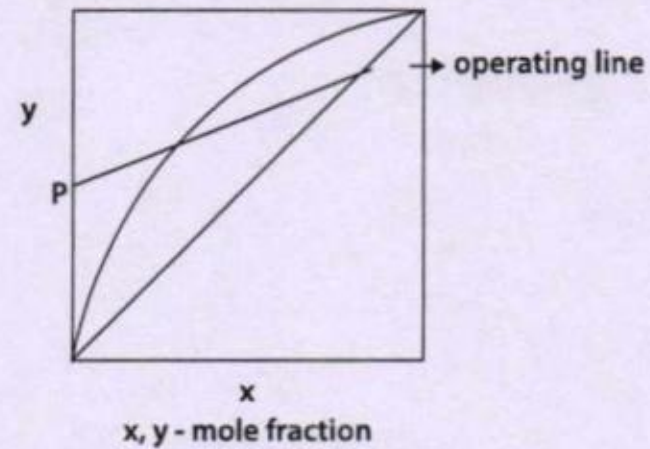

(A)  $X_d/R - 1$

(B)  $X_d/R + 1$

(C)  $R/X_d - 1$

(D)  $R/X_d + 1$

Where,  $X_d$  - concentration of distillate and  $R$ -reflux ratio

Space For Rough Work

## SPACE FOR ROUGH WORK

