

DU MSc Electronics

Topic:- DU_J18_MSC_ELEC

1) A DC voltage source is connected across a series R–L–C circuit. Under steady conditions, the applied DC voltage drops entirely across the: [Question ID = 52409]

1. L only [Option ID = 89630]
2. C only [Option ID = 89628]
3. R only [Option ID = 89629]
4. R and L combination [Option ID = 89631]

Correct Answer :-

- C only [Option ID = 89628]

2) A modulating signal is amplified by a 80% efficiency amplifier before being combined with a 20 kW carrier to generate an AM signal. For the system to operate at 100% modulation, the required DC input power to the amplifier would be [Question ID = 52466]

1. 6.25 kW [Option ID = 89859]
2. 5 kW [Option ID = 89856]
3. 8.46 kW [Option ID = 89857]
4. 12.5 kW [Option ID = 89858]

Correct Answer :-

- 12.5 kW [Option ID = 89858]

3) Ring modulator is used to produce: [Question ID = 52457]

1. USB [Option ID = 89821]
2. DSB-SC [Option ID = 89822]
3. VSB [Option ID = 89823]
4. SSB [Option ID = 89820]

Correct Answer :-

- DSB-SC [Option ID = 89822]

4) An amplifier has its average standard noise figure that cannot exceed 1.7 (Room temperature 290 K), the maximum average effective input noise temperature of this amplifier is [Question ID = 52465]

1. 235 K [Option ID = 89854]
2. 215 K [Option ID = 89853]
3. 255 K [Option ID = 89852]
4. 203 K [Option ID = 89855]

Correct Answer :-

- 203 K [Option ID = 89855]

5) How many interrupts can 8259 A handle: [Question ID = 52438]

1. 6 [Option ID = 89747]
2. 2 [Option ID = 89745]
3. 8 [Option ID = 89746]
4. 4 [Option ID = 89744]

Correct Answer :-

- 8 [Option ID = 89746]

6) The upper frequency of the thermocouple based instruments is limited by [Question ID = 52406]

1. only inductances of connecting leads [Option ID = 89617]
2. temperature coefficient of thermocouple [Option ID = 89618]
3. only capacitances of connecting leads [Option ID = 89616]
4. capacitances and inductances of connecting leads [Option ID = 89619]

Correct Answer :-

- capacitances and inductances of connecting leads [Option ID = 89619]

7) In FM wave the maximum frequency deviation is 50 kHz and the modulating frequency is 5 kHz, the modulation index is [Question ID = 52463]

1. 15 [Option ID = 89844]
2. 20 [Option ID = 89846]
3. 10 [Option ID = 89845]
4. 25 [Option ID = 89847]

Correct Answer :-

- 10 [Option ID = 89845]

8) The data transmission rate of a modem is measured in [Question ID = 52468]

1. baud rate [Option ID = 89866]
2. bits per second [Option ID = 89865]
3. bytes per second [Option ID = 89864]
4. megahertz [Option ID = 89867]

Correct Answer :-

- bits per second [Option ID = 89865]

9) At higher frequencies, the CMRR of an op-amp [Question ID = 52420]

1. becomes zero [Option ID = 89675]
2. remains constant [Option ID = 89674]
3. increases [Option ID = 89672]
4. reduces [Option ID = 89673]

Correct Answer :-

- reduces [Option ID = 89673]

10) The instruction RST 7 is a: [Question ID = 52436]

1. Restart instruction that begins the execution of a program [Option ID = 89736]
2. One –byte call to the memory address 0038 H [Option ID = 89739]
3. One –byte call to the memory address 0007 H [Option ID = 89737]
4. Hardware interrupt [Option ID = 89738]

Correct Answer :-

- One –byte call to the memory address 0038 H [Option ID = 89739]

11) After REST, the CPU begins execution from memory location: [Question ID = 52439]

1. FFFF H [Option ID = 89749]
2. 0001 H [Option ID = 89750]
3. 8000 H [Option ID = 89751]
4. 0000 H [Option ID = 89748]

Correct Answer :-

- 0000 H [Option ID = 89748]

12) Load regulation is determined by [Question ID = 52424]

1. zener current and load current [Option ID = 89691]
2. changes in load resistance and input voltage [Option ID = 89690]
3. changes in load current and output voltage. [Option ID = 89689]
4. changes in load current and input voltage. [Option ID = 89688]

Correct Answer :-

- changes in load current and output voltage. [Option ID = 89689]

13) The push source copies a word from source to: [Question ID = 52440]

1. Stack [Option ID = 89752]
2. Destination [Option ID = 89755]
3. Register [Option ID = 89754]
4. Memory [Option ID = 89753]

Correct Answer :-

- Stack [Option ID = 89752]

14) The diffraction pattern shown in the figure is obtained in the far field when a collimated beam of monochromatic light illuminates an N-slits aperture. The value of N is

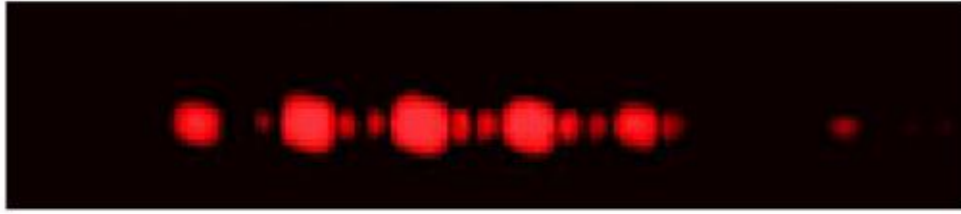

[Question ID = 52391]

1. cannot be estimated [Option ID = 89559]
2. 5 [Option ID = 89558]
3. 4 [Option ID = 89556]
4. 2 [Option ID = 89557]

Correct Answer :-

- 4 [Option ID = 89556]

15) A system has three stage cascaded amplifier each stage having a power gain of 10 dB and noise figure of 6 dB. the overall noise figure is [Question ID = 52464]

1. 4.33 [Option ID = 89848]
2. 1 [Option ID = 89851]
3. 2.22 [Option ID = 89850]
4. 7.54 [Option ID = 89849]

Correct Answer :-

- 4.33 [Option ID = 89848]

16) The Laplace Transform of the function shown in the figure (sum of two delta functions) is given by

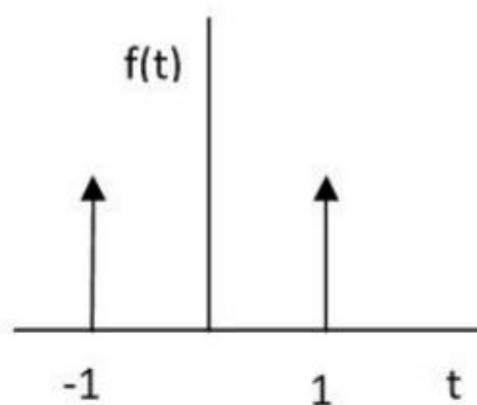

[Question ID = 52373]

1. $2j \sin s$ [Option ID = 89485]
2. $2 \cos s$ [Option ID = 89486]
3. $2j \cos s$ [Option ID = 89484]
4. zero [Option ID = 89487]

Correct Answer :-

- $2 \cos s$ [Option ID = 89486]

17) A varactor diode exhibits [Question ID = 52425]

1. A variable resistance that depends on reverse voltage [Option ID = 89692]
2. A variable capacitance that depends on forward voltage [Option ID = 89695]
3. A variable capacitance that depends on forward current [Option ID = 89694]

4. A variable capacitance that depends on reverse voltage [Option ID = 89693]

Correct Answer :-

- A variable capacitance that depends on reverse voltage [Option ID = 89693]

18) The signal $m(t) = \cos 2000\pi t + 2 \cos 4000\pi t$ is multiplied by the carrier $c(t) = 100 \cos 2\pi f_c t$. The expression for the upper sideband (USB) signal is

[Question ID = 52467]

1. $x(t) = 50 \cos 2\pi(fc + 2000)t + 100 \cos 2\pi(fc + 4000)t$ [Option ID = 89861]
2. $x(t) = 100 \cos 2\pi(fc + 2000)t + 200 \cos 2\pi(fc + 4000)t$ [Option ID = 89863]
3. $x(t) = 50 \cos 2\pi(fc + 1000)t + 100 \cos 2\pi(fc + 2000)t$ [Option ID = 89860]
4. $x(t) = 100 \cos 2\pi(fc + 1000)t + 200 \cos 2\pi(fc + 2000)t$ [Option ID = 89862]

Correct Answer :-

- $x(t) = 50 \cos 2\pi(fc + 1000)t + 100 \cos 2\pi(fc + 2000)t$ [Option ID = 89860]

19) A coil of 250 turns is placed in a magnetic field which is changing at a rate of $500 \mu\text{Wb/s}$. The induced voltage across this coil is,

[Question ID = 52446]

1. 5 KV [Option ID = 89776]
2. $0.2 \mu\text{V}$ [Option ID = 89777]
3. 12.5 V [Option ID = 89779]
4. 0.125 V [Option ID = 89778]

Correct Answer :-

- 0.125 V [Option ID = 89778]

20) For static electric and magnetic fields in an inhomogeneous source free medium which of the following is the correct form of the two Maxwell's equations

[Question ID = 52451]

1. $\nabla \times \vec{E} = 0 \quad \nabla \cdot \vec{B} = 0$ [Option ID = 89797]
2. $\nabla \times \vec{B} = 0 \quad \nabla \times \vec{E} = 0$ [Option ID = 89798]
3. $\nabla \cdot \vec{E} = 0 \quad \nabla \cdot \vec{B} = 0$ [Option ID = 89799]
4. $\nabla \times \vec{B} = 0 \quad \nabla \cdot \vec{E} = 0$ [Option ID = 89796]

Correct Answer :-

- $\nabla \times \vec{E} = 0 \quad \nabla \cdot \vec{B} = 0$ [Option ID = 89797]

21)

An 8085 assembly language program is given below. Assume that the carry flag is initially unset. The content of the accumulator after the execution of the program is

```
MVI A, 07H
RLC
MOV B, A
RLC
RLC
ADD B
RRC
```

[Question ID = 52443]

1. 64H [Option ID = 89765]
2. 15H [Option ID = 89767]
3. 23H [Option ID = 89764]
4. 42H [Option ID = 89766]

Correct Answer :-

- 23H [Option ID = 89764]

22) If the transistor parameters are $\beta=180$, early voltage $V_A=140$ V and if it is biased at $I_{CQ}=2$ mA, the values of hybrid- π parameter g_m , r_π and r_o are respectively

[Question ID = 52419]

1. 77.2 mA/V, 2.33 k Ω , 70 k Ω [Option ID = 89668]
2. 77.2 mA/V, 70 k Ω , 2.33 k Ω [Option ID = 89671]
3. 14 A/V, 90 k Ω , 2.33 k Ω [Option ID = 89670]
4. 14 A/V, 2.33 k Ω , 90 k Ω [Option ID = 89669]

Correct Answer :-

- 77.2 mA/V, 2.33 k Ω , 70 k Ω [Option ID = 89668]

23) A point charge Q is placed in the centre of a hollow conducting spherical shell of inner radius a and outer radius b . A net charge q is placed on the conducting shell. If the electric potential is assumed to be zero at infinity, the magnitude of potential at $a < r < b$, is

[Question ID = 52453]

1. $\frac{Q}{4\pi\epsilon_0 a}$ [Option ID = 89807]
2. $\frac{Q+q}{4\pi\epsilon_0 r}$ [Option ID = 89805]
3. $\frac{Q}{4\pi\epsilon_0 r}$ [Option ID = 89806]
4. $\frac{Q+q}{4\pi\epsilon_0 b}$ [Option ID = 89804]

Correct Answer :-

• $\frac{Q+q}{4\pi\epsilon_0 b}$ [Option ID = 89804]

24) A material has $\sigma = 0$ and $\epsilon_r = 1$. The magnetic field intensity is $\vec{H} = 4 \cos(10^6 t - 0.01z) \hat{a}_y$ A/m. The electric field intensity \vec{E} (in kV/m) is

[Question ID = 52450]

1. $\vec{E} = 4.52 \cos(10^6 t - 0.01z)$ [Option ID = 89793]
2. $\vec{E} = 6.5 \sin(10^6 t - 0.01z)$ [Option ID = 89792]
3. $\vec{E} = 4.52 \sin(10^6 t - 0.01z)$ [Option ID = 89794]
4. $\vec{E} = 6.5 \cos(10^6 t - 0.01z)$ [Option ID = 89795]

Correct Answer :-

• $\vec{E} = 4.52 \sin(10^6 t - 0.01z)$ [Option ID = 89794]

25)

An 8085 executes the following instructions

2710H LXI H, 30A0H

2713H DAD H

2714H PCHL

All the addresses and constants are in Hex. Let PC be the contents of the program counter and HL be the contents of the HL register pair just after executing PCHL.

Which of the following statements is correct?

[Question ID = 52444]

1. PC = 30A0H HL = 2715H [Option ID = 89770]
2. PC = 6140H HL = 6140H [Option ID = 89768]
3. PC = 6140H HL = 2715H [Option ID = 89771]
4. PC = 2715H HL = 30A0H [Option ID = 89769]

Correct Answer :-

• PC = 6140H HL = 6140H [Option ID = 89768]

26)

In the following circuit the output Z is

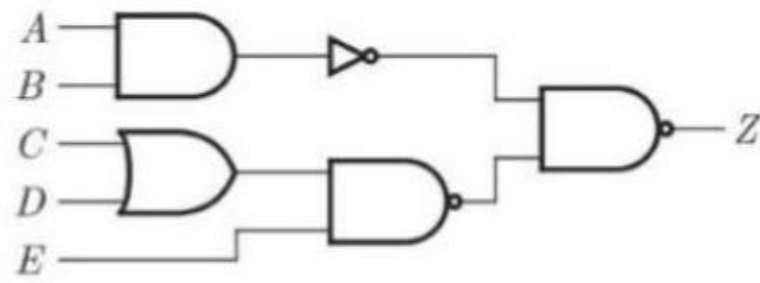

[Question ID = 52433]

1. $\overline{AB} + CD + E$ [Option ID = 89726]
2. $AB(C + D)E$ [Option ID = 89724]
3. $AB + (C + D)E$ [Option ID = 89725]
4. $AB + CDE$ [Option ID = 89727]

Correct Answer :-

- $AB + (C + D)E$ [Option ID = 89725]

27) For what value of a is the matrix $\begin{bmatrix} -4 & 2 \\ -6 & a \end{bmatrix}$ singular

[Question ID = 52370]

1. 3 [Option ID = 89472]
2. 6 [Option ID = 89474]
3. -3 [Option ID = 89473]
4. 2 [Option ID = 89475]

Correct Answer :-

- 3 [Option ID = 89472]

28) In C language, what is the output of the following code

```
int main()
{
    int a, b;
    a = 99;
    b = a / 2;
    printf("%03d",b);
}
```

[Question ID = 52392]

1. 50 [Option ID = 89562]
2. 049 [Option ID = 89561]
3. 49.5 [Option ID = 89560]
4. Error [Option ID = 89563]

Correct Answer :-

- 049 [Option ID = 89561]

- 29) The raised cosine pulse $p(t)$ is used for zero ISI in digital communications. The expression for $p(t)$ with unity roll-off factor is given by $p(t) = \frac{\sin(4\pi Wt)}{4\pi Wt(1 - 16W^2t^2)}$. The value of $p(t)$ at $t = \frac{1}{4W}$ is

[Question ID = 52461]

1. ∞ [Option ID = 89838]
2. 0 [Option ID = 89836]
3. -0.5 [Option ID = 89837]
4. 0.5 [Option ID = 89839]

Correct Answer :-

- 0.5 [Option ID = 89839]

- 30) Pure silicon has electrical resistivity of $3000 \Omega\text{-m}$. If the free carrier density is $1.1 \times 10^6 /\text{m}^3$ and the electron mobility is three times that of hole mobility then mobility of electron is

[Question ID = 52398]

1. $2.42 \times 10^9 \text{ m}^2/\text{Vs}$ [Option ID = 89586]
2. $1.41 \times 10^9 \text{ m}^2/\text{Vs}$ [Option ID = 89585]
3. $0.70 \times 10^9 \text{ m}^2/\text{Vs}$ [Option ID = 89584]
4. $1.18 \times 10^3 \text{ m}^2/\text{Vs}$ [Option ID = 89587]

Correct Answer :-

- $1.41 \times 10^9 \text{ m}^2/\text{Vs}$ [Option ID = 89585]

- 31) The figure shows a binary counter with synchronous clear input. With the decoding logic shown, the counter works as a

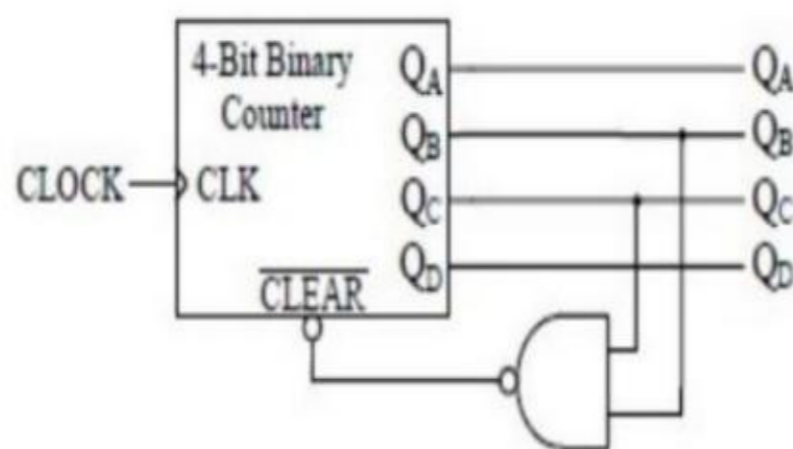

[Question ID = 52430]

1. Mode-6 counter [Option ID = 89715]
2. Mode-5 counter [Option ID = 89712]
3. Mode-4 counter [Option ID = 89713]
4. Mode-10 counter [Option ID = 89714]

Correct Answer :-

- Mode-6 counter [Option ID = 89715]

32)

What will be the value of the definite integral $\int_0^{\frac{\pi}{3}} e^{ix} dx$?

[Question ID = 52380]

1. $\sqrt{\frac{3}{2} - i\frac{1}{2}}$ [Option ID = 89515]
2. $\frac{\sqrt{3}}{2} - i\frac{1}{2}$ [Option ID = 89512]
3. $\sqrt{\frac{3}{2} + i\frac{1}{2}}$ [Option ID = 89514]
4. $\frac{\sqrt{3}}{2} + i\frac{1}{2}$ [Option ID = 89513]

Correct Answer :-

- $\frac{\sqrt{3}}{2} + i\frac{1}{2}$ [Option ID = 89513]

33) Let C be a circle $|z - 1| = 3$ in the complex plane, then $\int_C \frac{\cos z}{z - \pi} dz$, C being traversed clockwise equals

[Question ID = 52382]

1. 0 [Option ID = 89523]
2. πi [Option ID = 89522]
3. $2\pi i$ [Option ID = 89521]
4. $-2\pi i$ [Option ID = 89520]

Correct Answer :-

- $-2\pi i$ [Option ID = 89520]

34)

Consider the assembly language program given below:

```
MVI A, 84H
MVI B, ABH
SUB B
MOV D, A
HLT
```

If 8085 is operating at a frequency of 3 MHz then total time required to execute the above program is

[Question ID = 52442]

1. 16 μ sec [Option ID = 89760]

2. $7 \mu\text{sec}$ [Option ID = 89762]
3. $10 \mu\text{sec}$ [Option ID = 89761]
4. $9 \mu\text{sec}$ [Option ID = 89763]

Correct Answer :-

- $9 \mu\text{sec}$ [Option ID = 89763]

- 35) If the input to the digital circuit (in the figure) consisting of a cascade of 20 XOR-gates is X , then the output Y is equal to

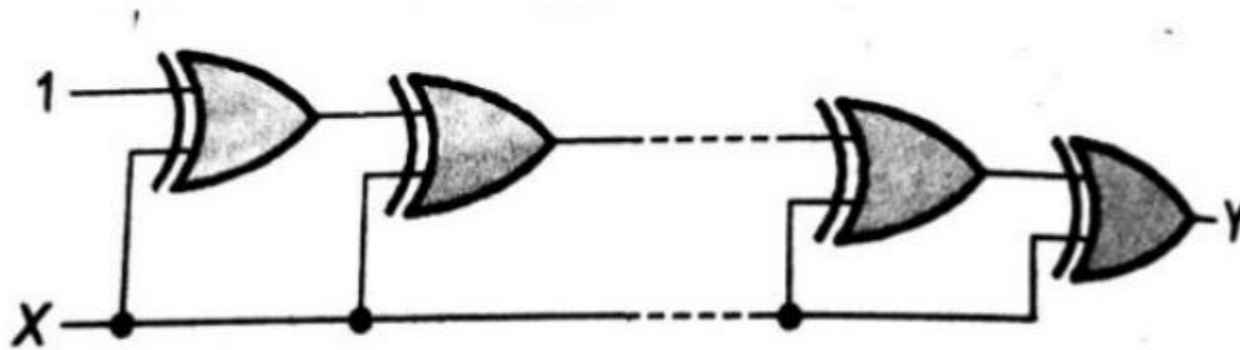

[Question ID = 52428]

1. X [Option ID = 89706]
2. X' [Option ID = 89707]
3. 0 [Option ID = 89704]
4. 1 [Option ID = 89705]

Correct Answer :-

- 1 [Option ID = 89705]

- 36) If a dielectric material of ϵ_r is kept in an electric field \vec{E} V/m. The polarization in this dielectric is given by

[Question ID = 52447]

1. $\vec{P} = \epsilon_o (\epsilon_r + 1) \vec{E}$ [Option ID = 89781]
2. $\vec{P} = \vec{E} / \epsilon_o (\epsilon_r + 1)$ [Option ID = 89783]
3. $\vec{P} = \vec{E} / \epsilon_o (\epsilon_r - 1)$ [Option ID = 89780]
4. $\vec{P} = \epsilon_o (\epsilon_r - 1) \vec{E}$ [Option ID = 89782]

Correct Answer :-

- $\vec{P} = \epsilon_o (\epsilon_r - 1) \vec{E}$ [Option ID = 89782]

- 37) The Laplace transform of e^{i7t} is

[Question ID = 52379]

1. $\frac{s-7}{s^2+49}$ [Option ID = 89510]
2. $\frac{s-7i}{s^2+49}$ [Option ID = 89508]

3. $\frac{s+7i}{s^2+49}$ [Option ID = 89511]
 $\frac{s+7}{s^2+49}$
4. $\frac{s+7i}{s^2+49}$ [Option ID = 89509]

Correct Answer :-

- $\frac{s+7i}{s^2+49}$ [Option ID = 89511]

38) The inverse of the complex number $\frac{2+3i}{2-3i}$ is

[Question ID = 52375]

1. $\frac{5}{13} + i\frac{12}{13}$ [Option ID = 89492]
 $\frac{5}{13} - i\frac{12}{13}$ [Option ID = 89495]
 $-\frac{5}{13} - i\frac{12}{13}$ [Option ID = 89494]
 $-\frac{5}{13} + i\frac{12}{13}$ [Option ID = 89493]

Correct Answer :-

- $-\frac{5}{13} - i\frac{12}{13}$ [Option ID = 89494]

39)

Consider the following Amplitude Modulated (AM) signal, where $f_m < B$
 $X_{AM}(t) = 10(1 + 0.5 \sin 2\pi f_m t) \cos 2\pi f_c t$

The AM signal gets added to a noise with Power Spectral Density $S_n(f)$ given in the figure below. The ratio of average sideband power to mean noise power would be:

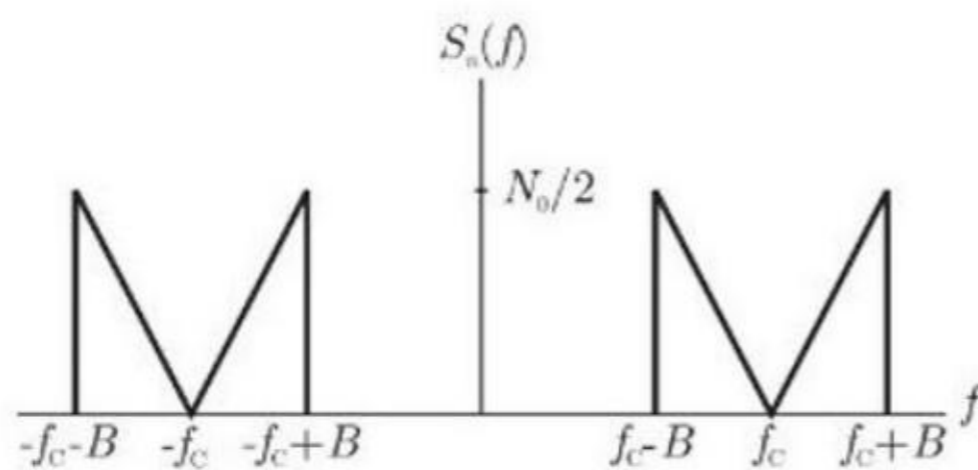

[Question ID = 52458]

1. $\frac{25}{2N_0B}$ [Option ID = 89826]

2. $\frac{25}{8N_o B}$ [Option ID = 89825]

3. $\frac{4N_o B}{25}$ [Option ID = 89824]

4. $\frac{N_o B}{25}$ [Option ID = 89827]

Correct Answer :-

• $\frac{25}{4N_o B}$ [Option ID = 89824]

40) A digital frequency meter has $8\frac{1}{2}$ digit display and an accuracy of $1 \text{ LSD} \pm (1 \times 10^{-5})$. The measurement error in measuring the frequency of 100 kHz by this meter is

[Question ID = 52407]

1. $\pm 1 \text{ Hz}$ [Option ID = 89620]

2. $\pm 2 \text{ Hz}$ [Option ID = 89622]

3. $\pm 5 \text{ Hz}$ [Option ID = 89623]

4. $\pm 10 \text{ Hz}$ [Option ID = 89621]

Correct Answer :-

• $\pm 2 \text{ Hz}$ [Option ID = 89622]

41) The probability percentage of finding the electron in an energy level kT above the Fermi level is [take $e = 2.71$]

[Question ID = 52397]

1. 65 % [Option ID = 89580]

2. 27 % [Option ID = 89581]

3. 50 % [Option ID = 89582]

4. 75 % [Option ID = 89583]

Correct Answer :-

• 27 % [Option ID = 89581]

42) Three 330Ω resistors are connected in series. One has tolerance of 10% and other two have 5% each. The maximum value of total resistance is

[Question ID = 52405]

1. 1056Ω [Option ID = 89612]

2. 1237.5Ω [Option ID = 89615]

3. 990Ω [Option ID = 89613]

4. 1015Ω [Option ID = 89614]

Correct Answer :-

- 1056 Ω [Option ID = 89612]

43) A certain pulse waveform has a frequency of 200 kHz and a pulse width of 0.25 μs . The percent duty cycle for the pulse waveform is

[Question ID = 52418]

1. 50% [Option ID = 89664]
2. 25% [Option ID = 89665]
3. 10% [Option ID = 89666]
4. 5% [Option ID = 89667]

Correct Answer :-

- 5% [Option ID = 89667]

44) In C language, what is the output of the following code

```
int main()
{
    enum course {msc, mtech, phd};
    int i = 0;
    for(i = msc; i <= phd; i++)
    {
        printf("%d ", i);
    }
}
```

[Question ID = 52393]

1. 0 1 2 [Option ID = 89567]
2. Error [Option ID = 89565]
3. msc mtech phd [Option ID = 89564]
4. 2 1 0 [Option ID = 89566]

Correct Answer :-

- 0 1 2 [Option ID = 89567]

45)

The attenuation in an optical fiber cable is 0.6 dB/km at 1300 nm and 0.3dB/km at 1550 nm. If 200 μW power is launched into the fiber at 1300 nm and 100 μW at 1550 nm, the total output power from the fiber after a length of 10 km is

[Question ID = 52452]

1. 50 μW [Option ID = 89800]
2. 100 μW [Option ID = 89802]
3. 120 μW [Option ID = 89801]
4. 150 μW [Option ID = 89803]

Correct Answer :-

- $100 \mu\text{W}$ [Option ID = 89802]

46)

A coil having resistance of 10Ω and inductance of 1 H is switched on to a direct voltage of 100 V . The rate of change of current when $t = L/R$ is

[Question ID = 52417]

1. 18 A/sec [Option ID = 89662]
2. 10 A/sec [Option ID = 89661]
3. 25 A/sec [Option ID = 89660]
4. 36.8 A/sec [Option ID = 89663]

Correct Answer :-

- 36.8 A/sec [Option ID = 89663]

47) The electric field of a plane wave propagating in free space is given by

$$\vec{E} = 8 \sin(3\pi \times 10^8 t - \beta z) \hat{x} + 6 \sin(3\pi \times 10^8 t - \beta z + \frac{\pi}{4}) \hat{y} \text{ V/m}$$

The value of β and polarization of the wave respectively are

[Question ID = 52454]

1. 2π , elliptical [Option ID = 89811]
2. 2π , linear [Option ID = 89810]
3. π , circular [Option ID = 89809]
4. π , elliptical [Option ID = 89808]

Correct Answer :-

- π , elliptical [Option ID = 89808]

48) \overline{BHE} of 8086 microprocessor signal is used to interface the

[Question ID = 52441]

1. DMA [Option ID = 89759]
2. I/O [Option ID = 89758]
3. Even memory bank [Option ID = 89756]
4. Odd memory bank [Option ID = 89757]

Correct Answer :-

- Odd memory bank [Option ID = 89757]

49) For a dielectric material in which the electric field is 150 kV/m and electric susceptibility is 4.75 , the magnitude of electric flux density is

[Question ID = 52448]

1. $6.31 \mu\text{C/m}^2$ [Option ID = 89785]
2. $7.63 \mu\text{C/m}^2$ [Option ID = 89786]

3. $7.12 \mu\text{C}/\text{m}^2$ [Option ID = 89787]
4. $8.62 \mu\text{C}/\text{m}^2$ [Option ID = 89784]

Correct Answer :-

- $7.63 \mu\text{C}/\text{m}^2$ [Option ID = 89786]

50) In the figure, the LED

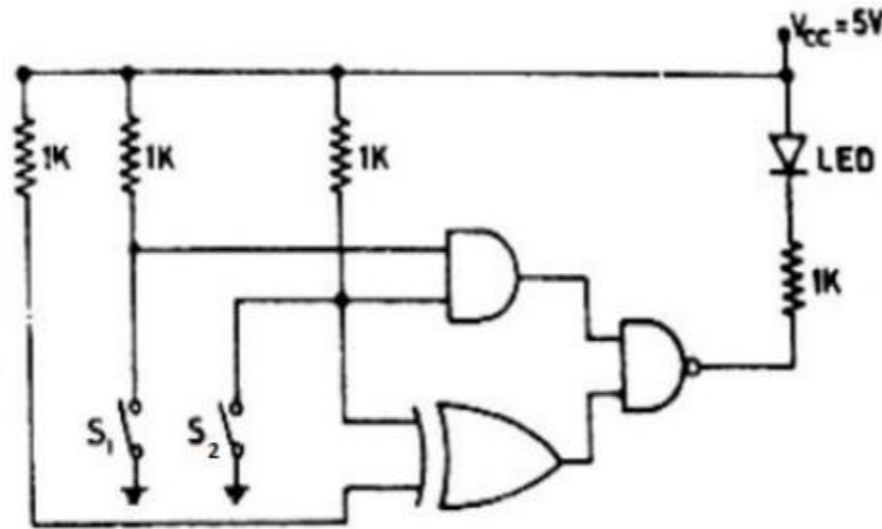

[Question ID = 52429]

1. emits light when only S1 is closed and S2 is open. [Option ID = 89711]
2. emits light when both S1 and S2 are open. [Option ID = 89710]
3. emits light when both S1 and S2 are closed. [Option ID = 89709]
4. does not emit light, irrespective of the switch positions. [Option ID = 89708]

Correct Answer :-

- does not emit light, irrespective of the switch positions. [Option ID = 89708]

51) The average value of the function $f(x) = 3x^2 + 4x + 7$ in the interval 0 to 4 is

[Question ID = 52377]

1. 49 [Option ID = 89501]
2. 59.5 [Option ID = 89500]
3. 119 [Option ID = 89502]
4. 238 [Option ID = 89503]

Correct Answer :-

52) Which of the following functions represents the solution of the Schrodinger equation for an electron in the 2s state of a hydrogen atom? (a_0 is the Bohr radius and C is a constant)

[Question ID = 52389]

1. $C \left(1 - \frac{r}{2a_0} \right) \exp\left(-\frac{r}{a_0}\right) \sin(\theta)$ [Option ID = 89548]

2. $C \left(1 - \frac{r}{2a_0} \right) \exp\left(-\frac{r}{2a_0}\right)$ [Option ID = 89549]

3. $C \left(1 - \frac{r}{2a_0} \right) \exp\left(-\frac{r}{a_0}\right) \cos(\theta)$ [Option ID = 89551]

4. $C \exp\left(-\frac{r}{a_0}\right)$ [Option ID = 89550]

Correct Answer :-

• $C \left(1 - \frac{r}{2a_0} \right) \exp\left(-\frac{r}{2a_0}\right)$ [Option ID = 89549]

53) The inductance per unit length and characteristic impedance of a lossless transmission line are L and Z_0 respectively. The velocity of the travelling wave on the line is given by

[Question ID = 52455]

1. $\frac{1}{Z_0 L}$ [Option ID = 89813]

2. $\frac{1}{Z_0 \sqrt{L}}$ [Option ID = 89812]

3. $\frac{Z_0 L}{Z_0}$ [Option ID = 89815]

4. $\frac{L}{L}$ [Option ID = 89814]

Correct Answer :-

• $\frac{Z_0}{L}$ [Option ID = 89814]

54)

If matrix A is defined as $A = \begin{bmatrix} 1 & 2 & 3 \\ 0 & -2 & 6 \\ 0 & 0 & -3 \end{bmatrix}$, the eigen values of $3A^3 + 5A^2 + 6A + I$ are

[Question ID = 52383]

1. 15, -15, 53 [Option ID = 89525]

2. 15, -15, -53 [Option ID = 89527]

3. 15, 5, -15 [Option ID = 89526]

4. 5, -5, -53 [Option ID = 89524]

Correct Answer :-

• 15, -15, -53 [Option ID = 89527]

55)

Find the correct match between group-I and group-II

Group-I

- P. LED
- Q. Avalanche photodiode
- R. Tunnel diode
- S. LASER

Group-II

- 1. heavy doping
- 2. coherent radiation
- 3. spontaneous emission
- 4. current gain

[Question ID = 52399]

1. P Q R S
3 4 1 2 [Option ID = 89588]

2. P Q R S
2 3 4 1 [Option ID = 89589]

3. P Q R S
3 4 2 1 [Option ID = 89590]

4. P Q R S
4 2 1 3 [Option ID = 89591]

Correct Answer :-

- 3 4 1 2 [Option ID = 89588]

56) For the RLC parallel resonant circuit when $R=6\text{ k}\Omega$, $L=40\text{ mH}$ and $C=0.25\text{ }\mu\text{F}$, the quality factor Q is

[Question ID = 52413]

- 1. 15 [Option ID = 89646]
- 2. 35 [Option ID = 89647]
- 3. 5 [Option ID = 89644]
- 4. 20 [Option ID = 89645]

Correct Answer :-

- 15 [Option ID = 89646]

57) $\int_0^{\infty} \frac{e^{-t} \sin t}{t} dt$ is

[Question ID = 52376]

- 1. ∞ [Option ID = 89499]
- 2. $\pi/2$ [Option ID = 89498]
- 3. π [Option ID = 89496]
- 4. $\pi/4$ [Option ID = 89497]

Correct Answer :-

- $\pi/4$ [Option ID = 89497]

58)

Which of the following Boolean expressions correctly represents the relation between P, Q, R and M_1

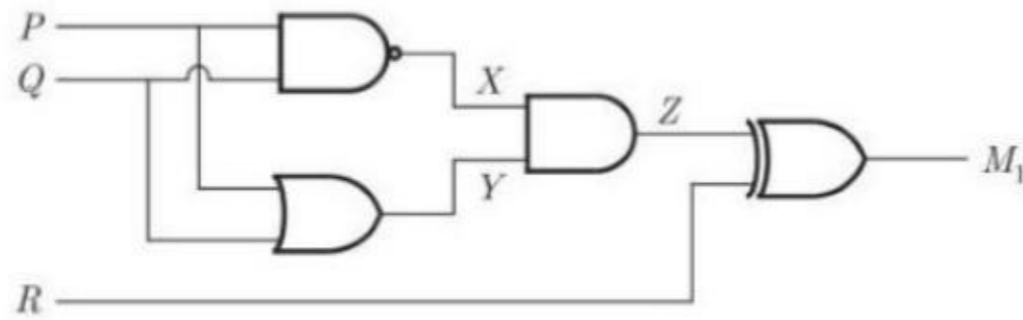

[Question ID = 52434]

1. $M_1 = (P \text{ AND } Q) \text{ XOR } R$ [Option ID = 89730]
2. $M_1 = (P \text{ NOR } Q) \text{ XOR } R$ [Option ID = 89731]
3. $M_1 = (P \text{ XOR } Q) \text{ XOR } R$ [Option ID = 89728]
4. $M_1 = (P \text{ OR } Q) \text{ XOR } R$ [Option ID = 89729]

Correct Answer :-

- $M_1 = (P \text{ XOR } Q) \text{ XOR } R$ [Option ID = 89728]

59) In a uniformly doped BJT, assume that N_E , N_B and N_C are the emitter, base and collector doping in atoms/cm³, respectively. If the emitter injection efficiency of the BJT is close to unity, which one of the following condition is TRUE?

[Question ID = 52402]

1. $N_E \ll N_B$ and $N_B < N_C$ [Option ID = 89603]
2. $N_E < N_B < N_C$ [Option ID = 89601]
3. $N_E \gg N_B$ and $N_B > N_C$ [Option ID = 89600]
4. $N_E = N_B = N_C$ [Option ID = 89602]

Correct Answer :-

- $N_E \gg N_B$ and $N_B > N_C$ [Option ID = 89600]

60) A ramp voltage, $v(t) = 100t$ volts, is applied to an RC differentiating circuit with $R = 5 \text{ k } \Omega$ and $C = 4 \mu\text{F}$. The maximum output voltage is

[Question ID = 52408]

1. 2.0 volts [Option ID = 89626]
2. 10.0 volts [Option ID = 89624]
3. 50.0 volt [Option ID = 89627]
4. 0.2 volts [Option ID = 89625]

Correct Answer :-

- 2.0 volts [Option ID = 89626]

61)

The DC current gain (β) of BJT is 50. Assuming that the emitter injection efficiency is 0.995, the base transport factor is

[Question ID = 52401]

1. 0.523 [Option ID = 89597]
2. ∞ [Option ID = 89598]
3. 0.985 [Option ID = 89599]
4. 0.756 [Option ID = 89596]

Correct Answer :-

- 0.985 [Option ID = 89599]

62) In the AC network shown in the figure, the phasor voltage V_{AB} (in volts) is

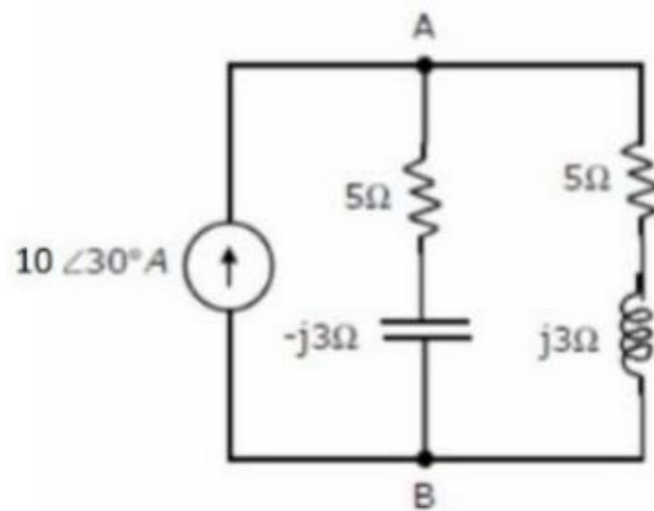

[Question ID = 52411]

1. $34\angle 30^\circ$ [Option ID = 89638]
2. $17\angle 30^\circ$ [Option ID = 89639]
3. $12.5\angle 30^\circ$ [Option ID = 89636]
4. $5\angle 30^\circ$ [Option ID = 89637]

Correct Answer :-

- $34\angle 30^\circ$ [Option ID = 89638]

63) Consider the addition of numbers with different bases

$$(X)_7 + (Y)_8 + (W)_{10} + (Z)_5 = (K)_9$$

If $X=36$, $Y=67$, $W=98$ and $K=241$ then find the value of Z

[Question ID = 52426]

1. $Z=34$ [Option ID = 89697]
2. $Z=42$ [Option ID = 89698]
3. $Z=26$ [Option ID = 89696]
4. $Z=16$ [Option ID = 89699]

Correct Answer :-

- $Z=34$ [Option ID = 89697]

64) An AC voltmeter is showing 3.2 V as the rms voltage of a sine wave. The average voltage value of this wave is

[Question ID = 52404]

1. 9.05 V [Option ID = 89609]
2. 4.53 V [Option ID = 89611]
3. 2.88 V [Option ID = 89608]
4. 2.03 V [Option ID = 89610]

Correct Answer :-

- 2.88 V [Option ID = 89608]

65) In C language, what is the output of the following code

```
void main()
{
    int a=12,b=6;
    if(a=5) b++;
    printf("%d %d", ++a, b++);
}
```

[Question ID = 52395]

1. Error [Option ID = 89574]
2. 13 7 [Option ID = 89572]
3. 6 7 [Option ID = 89575]
4. 12 7 [Option ID = 89573]

Correct Answer :-

- 6 7 [Option ID = 89575]

66) If $A_{DM} = 3200$ and $A_{CM} = 0.32$ for an op-amp, the CMRR is

[Question ID = 52421]

1. 70 dB [Option ID = 89678]
2. 1024 [Option ID = 89676]
3. 10000 [Option ID = 89679]
4. 1225 [Option ID = 89677]

Correct Answer :-

- 1024 [Option ID = 89676]

67) The amplitude of a random signal is uniformly distributed between -5V to 5V. If the signal to quantization noise ratio required in uniformly quantizing the signal is 43.5 dB, the step size of the quantization is approximately

[Question ID = 52460]

70) The length of the curve $y = \frac{2}{3}x^{3/2}$ between $x = 0$ and $x = 1$ is

[Question ID = 52378]

1. 0.67 [Option ID = 89507]
2. 0.27 [Option ID = 89505]
3. 1.22 [Option ID = 89504]
4. 1 [Option ID = 89506]

Correct Answer :-

- 1.22 [Option ID = 89504]

71) The truth table of a circuit is shown below, the Boolean expression for f is

A	B	C	f
0	0	0	0
0	0	1	0
0	1	0	0
0	1	1	1
1	0	0	0
1	0	1	0
1	1	0	1
1	1	1	0

[Question ID = 52435]

1. $\overline{B}(A+C)(\overline{A}+\overline{C})$ [Option ID = 89735]
2. $B(A+\overline{C})(\overline{A}+C)$ [Option ID = 89733]
3. $B(A+C)(\overline{A}+\overline{C})$ [Option ID = 89732]
4. $\overline{B}(A+\overline{C})(\overline{A}+C)$ [Option ID = 89734]

Correct Answer :-

- $B(A+C)(\overline{A}+\overline{C})$ [Option ID = 89732]

72) A mixer stage has a noise figure of 20 dB. This mixer stage is preceded by an amplifier which has a noise figure of 9 dB and an available power gain of 15 dB. The overall noise figure referred to the input is

[Question ID = 52462]

1. 11.07 [Option ID = 89841]
2. 16 [Option ID = 89840]
3. 6.76 [Option ID = 89843]
4. 21 [Option ID = 89842]

Correct Answer :-

- 11.07 [Option ID = 89841]

73)

Consider the differential equation $\frac{d^2 y}{dx^2} + 2\frac{dy}{dx} + y = 0$. If $y(0) = 0$ and $\left(\frac{dy}{dx}\right)_{x=0} = 1$, then the value of $y(2)$ is

[Question ID = 52381]

1. 1 [Option ID = 89518]
2. 0 [Option ID = 89519]
3. 0.27 [Option ID = 89516]
4. 0.54 [Option ID = 89517]

Correct Answer :-

- 0.27 [Option ID = 89516]

74) Let $m(t) = \cos(4\pi \times 10^3 t)$ be the message signal and $c(t) = 5 \cos(2\pi \times 10^6 t)$ be the carrier are used to generate an FM signal. If the frequency deviation of the generated FM signal is three times the transmission bandwidth of the AM signal, then the coefficient of the term $\cos(2\pi(1008 \times 10^3 t))$ in the FM signal (in terms of the Bessel coefficients) is

[Question ID = 52459]

1. $5 J_4(3)$ [Option ID = 89831]
2. $\frac{5}{2} J_8(3)$ [Option ID = 89829]
3. $\frac{5}{2} J_8(4)$ [Option ID = 89830]
4. $5 J_4(6)$ [Option ID = 89828]

Correct Answer :-

- $5 J_4(6)$ [Option ID = 89828]

75) A steel cable of cross section 1 cm^2 is used to support an elevator weighing 5000 kg. If the stress in the cable is not to exceed 20% of its elastic limit of $40,000 \text{ kg/cm}^2$, the maximum possible upward acceleration can be

[Question ID = 52386]

1. 5.88 cm/s^2 [Option ID = 89537]
2. 2548 cm/s [Option ID = 89539]
3. 0.6 cm/s^2 [Option ID = 89536]
4. 588 cm/s^2 [Option ID = 89538]

Correct Answer :-

- 588 cm/s^2 [Option ID = 89538]

76) A $p^+ - n$ junction has built-in potential of 0.8 V. The depletion layer width at reverse bias of 1.2 V is $2 \mu\text{m}$. For reverse bias of 7.2 V, the depletion layer width will be

[Question ID = 52400]

1. $1.41 \mu\text{m}$ [Option ID = 89595]
2. $2 \mu\text{m}$ [Option ID = 89592]
3. $4 \mu\text{m}$ [Option ID = 89593]
4. $16 \mu\text{m}$ [Option ID = 89594]

Correct Answer :-

- $4 \mu\text{m}$ [Option ID = 89593]

77) When a monochromatic light of wavelength 400 nm is used to study the diffraction from a single slit, it is observed that the angle between the central maximum and first minimum is 4×10^{-3} radians. What is the width of the slit?

[Question ID = 52388]

1. $100 \mu\text{m}$ [Option ID = 89544]
2. 100 nm [Option ID = 89545]
3. 50 nm [Option ID = 89547]
4. $50 \mu\text{m}$ [Option ID = 89546]

Correct Answer :-

- $100 \mu\text{m}$ [Option ID = 89544]

78) A p -channel depletion mode MOSFET has the following parameters: $K_p = 0.5 \text{ mA/V}^2$, $V_{th} = 2 \text{ V}$. For $V_{SG} = 0$ and $V_{SD} = 2 \text{ V}$, current I_D is

[Question ID = 52422]

1. 4 mA [Option ID = 89680]
2. 2 mA [Option ID = 89683]
3. 1 mA [Option ID = 89681]
4. 1.5 mA [Option ID = 89682]

Correct Answer :-

- 2 mA [Option ID = 89683]

79) A current of $i = 10^3 t$ is applied in a resistor of 5Ω . What is the magnitude of power between 0 to T m sec is (Assume $T = 2 \text{ m sec}$)

[Question ID = 52414]

1. 12 W [Option ID = 89650]
2. 0.75 W [Option ID = 89651]
3. 3.23 W [Option ID = 89648]
4. 6.67 W [Option ID = 89649]

Correct Answer :-

- 6.67 W [Option ID = 89649]

80)

The independent solutions of the equation $\frac{d^3 y}{dx^3} + 6 \frac{d^2 y}{dx^2} + 11 \frac{dy}{dx} + 6y = 0$

[Question ID = 52385]

1. $\sin x, \cos 2x$ and $\cos 3x$ [Option ID = 89533]

2. e^x, e^{2x}, e^{3x} [Option ID = 89532]

3. e^{-x}, e^{-2x}, e^{-3x} [Option ID = 89535]

4. $1/x, x^2, x^3$ [Option ID = 89534]

Correct Answer :-

• e^{-x}, e^{-2x}, e^{-3x} [Option ID = 89535]

81) In a AM signal the received signal power is 10^{-10} W with a maximum modulation signal of 5 kHz. The noise spectral density at the receiver input is 10^{-18} W/Hz. If the noise power is restricted to the message signal bandwidth only, the signal-to-noise ratio at the input to the receiver is:

[Question ID = 52456]

1. 43 dB [Option ID = 89817]

2. 66 dB [Option ID = 89816]

3. 33 dB [Option ID = 89819]

4. 56 dB [Option ID = 89818]

Correct Answer :-

• 43 dB [Option ID = 89817]

82) The value of the resistance R_1 in the figure below is

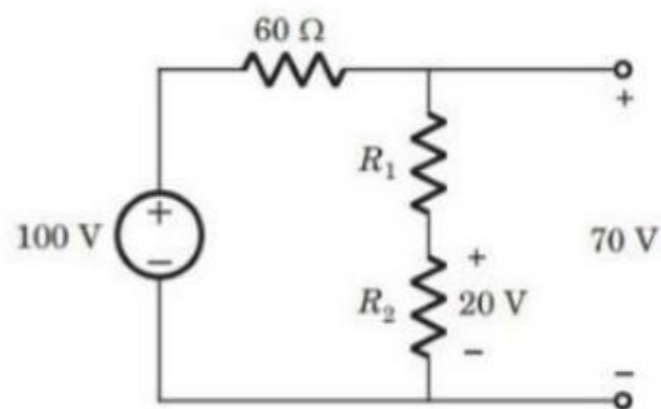

[Question ID = 52412]

1. 100Ω [Option ID = 89641]

2. $1 \text{ K}\Omega$ [Option ID = 89642]

3. 50Ω [Option ID = 89643]

4. 500Ω [Option ID = 89640]

Correct Answer :-

• 100Ω [Option ID = 89641]

83)

For the circuit shown in the figure, the delays of NOR gates, multiplexers and inverters are 2 ns, 1.5 ns and 1 ns, respectively. If all the inputs P, Q, R, S and T are applied at the same time. Calculate the total propagation delay for one cycle.

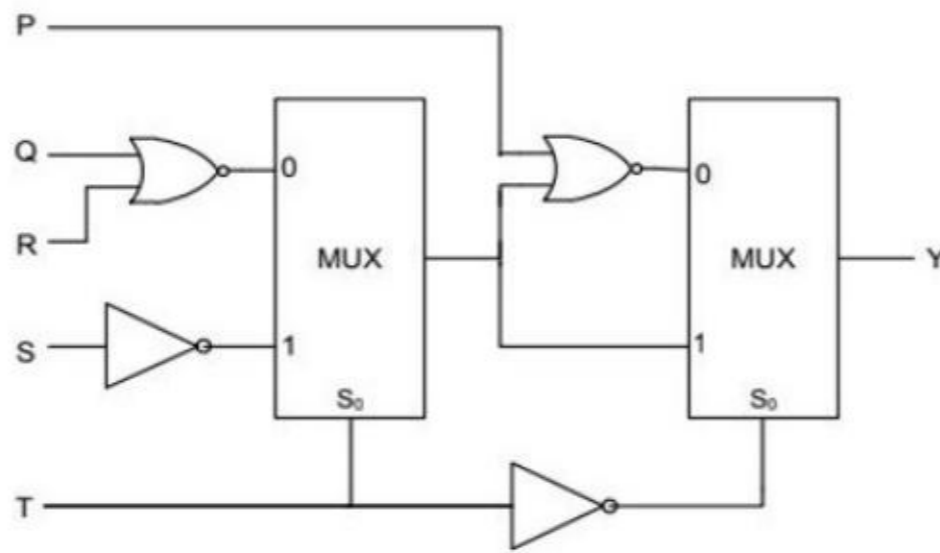

[Question ID = 52431]

1. 11 ns [Option ID = 89717]
2. 5 ns [Option ID = 89716]
3. 12 ns [Option ID = 89719]
4. 10 ns [Option ID = 89718]

Correct Answer :-

- 11 ns [Option ID = 89717]

84) An 8KB ROM with an active low Chip Select input (\overline{CS}) is to be used in an 8085 microprocessor based system. The ROM should occupy the address range 1000H to 2FFFH. The address lines are designated as A_{15} to A_0 , where A_{15} is the most significant address bit.

Which of the following logic expressions will generate the correct \overline{CS} signal for this ROM?

[Question ID = 52445]

1. $A_{15} \cdot A_{14} \cdot (A_{13} + A_{12})$ [Option ID = 89773]
2. $A_{15} + A_{14} + (A_{13} \cdot A_{12} + \overline{A_{13}} + \overline{A_{12}})$ [Option ID = 89772]
3. $\overline{A_{15}} \cdot \overline{A_{14}} + (A_{13} + \overline{A_{12}} + \overline{A_{13}} \cdot A_{12})$ [Option ID = 89774]
4. $\overline{A_{15}} + \overline{A_{14}} + A_{13} \cdot A_{12}$ [Option ID = 89775]

Correct Answer :-

- $A_{15} + A_{14} + (A_{13} \cdot A_{12} + \overline{A_{13}} + \overline{A_{12}})$ [Option ID = 89772]

85) The angle between the surfaces made by $x^2 + y^2 + z^2 = 25$ and $xy + z = 4$ at point $(1,1,-1)$ is

[Question ID = 52374]

1. $\cos^{-1}\left(\frac{1}{3}\right)$ [Option ID = 89488]

2. $\cos^{-1}\left(-\frac{1}{3}\right)$ [Option ID = 89490]

3. $\cos^{-1}\left(-\frac{1}{\sqrt{3}}\right)$ [Option ID = 89491]

4. $\cos^{-1}\left(\frac{1}{\sqrt{3}}\right)$ [Option ID = 89489]

Correct Answer :-

• $\cos^{-1}\left(\frac{1}{3}\right)$ [Option ID = 89488]

86) The directional derivative of $\phi = x^2yz + 4xz^2$ at $(1, -2, -1)$ in the direction $2\hat{i} - \hat{j} - 2\hat{k}$ is

[Question ID = 52384]

1. 18 [Option ID = 89531]

2. 36 [Option ID = 89530]

3. $\frac{3}{37}$ [Option ID = 89528]

4. $\frac{37}{3}$ [Option ID = 89529]

Correct Answer :-

• $\frac{37}{3}$ [Option ID = 89529]

87) The resistivity of a uniformly doped n -type silicon sample is $0.5 \Omega\text{-cm}$. If the electron mobility (μ_n) is $1250 \text{ cm}^2/\text{V-sec}$ and the charge of an electron is $1.6 \times 10^{-19} \text{ C}$, the donor impurity concentration (N_D) in the sample is

[Question ID = 52403]

1. $2.0 \times 10^{16} / \text{cm}^3$ [Option ID = 89604]

2. $2.5 \times 10^{15} / \text{cm}^3$ [Option ID = 89606]

3. $1.0 \times 10^{16} / \text{cm}^3$ [Option ID = 89605]

4. $5.0 \times 10^{15} / \text{cm}^3$ [Option ID = 89607]

Correct Answer :-

• $1.0 \times 10^{16} / \text{cm}^3$ [Option ID = 89605]

88) A half wave plate is designed in Lithium Niobate with $n_o=2.297$ and $n_e=2.208$ for use with the He Ne laser (633 nm). The possible thickness of the plate is

[Question ID = 52390]

1. 356 nm [Option ID = 89553]

2. 3.56 nm [Option ID = 89554]

3. 3.56 μm [Option ID = 89552]

4. 70 nm [Option ID = 89555]

Correct Answer :-

• $3.56 \mu\text{m}$ [Option ID = 89552]

89)

The emission spectrum of the doubly ionised Lithium atom Li^{++} ($Z=3$, $A=7$) is identical to that of hydrogen in which all the wavelengths are

[Question ID = 52387]

1. decreased by a factor of 9 [Option ID = 89543]
2. decreased by a factor of 81 [Option ID = 89541]
3. increased by a factor of 81 [Option ID = 89542]
4. increased by a factor of 9 [Option ID = 89540]

Correct Answer :-

• decreased by a factor of 9 [Option ID = 89543]

90) In the circuit shown below, current through the 5Ω resistor is

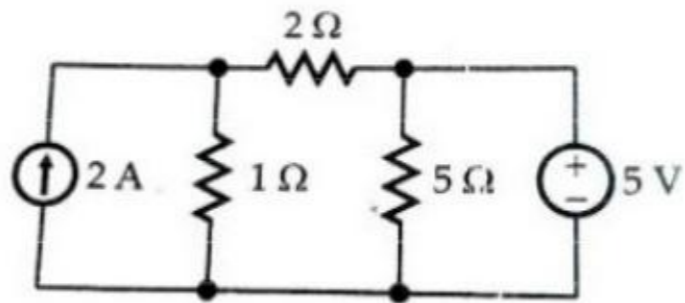

[Question ID = 52416]

1. 1 A [Option ID = 89656]
2. 1.5 A [Option ID = 89658]
3. 7 A [Option ID = 89659]
4. 2 A [Option ID = 89657]

Correct Answer :-

• 1 A [Option ID = 89656]

91)

Consider an ideal op-amp circuit shown in the figure with a closed loop voltage gain $A_v = 5$ and output range $-10 \text{ V} \leq V_o \leq 10 \text{ V}$. If the maximum current in any resistor is limited to $50 \mu\text{A}$, then R_1 and R_2 are

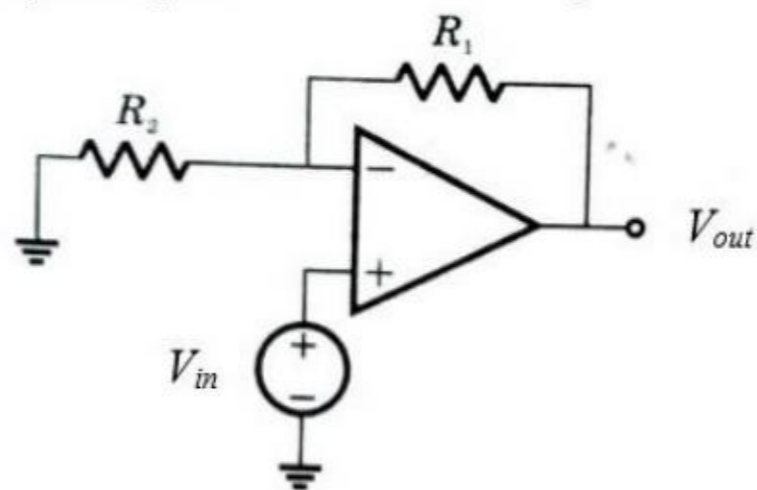

[Question ID = 52423]

1. $R_1 = 160 \text{ k}\Omega$ and $R_2 = 40 \text{ k}\Omega$ [Option ID = 89684]
2. $R_1 = 200 \text{ k}\Omega$ and $R_2 = 40 \text{ k}\Omega$ [Option ID = 89685]
3. $R_1 = 40 \text{ k}\Omega$ and $R_2 = 160 \text{ k}\Omega$ [Option ID = 89687]
4. $R_1 = 40 \text{ k}\Omega$ and $R_2 = 200 \text{ k}\Omega$ [Option ID = 89686]

Correct Answer :-

- $R_1 = 40 \text{ k}\Omega$ and $R_2 = 160 \text{ k}\Omega$ [Option ID = 89687]

92) When V_{GS} of FET changes from -3 to -3.1, the change in I_D is from 1.3 mA to 1.0 mA then g_m is

[Question ID = 52396]

1. 3 ms [Option ID = 89576]
2. 1 ms [Option ID = 89577]
3. 1.73ms [Option ID = 89578]
4. 9 ms [Option ID = 89579]

Correct Answer :-

- 3 ms [Option ID = 89576]

93) Two D flip-flops are connected as a synchronous counter that goes through the following $Q_B Q_A$ sequence $00 \rightarrow 11 \rightarrow 01 \rightarrow 10 \rightarrow 00 \dots\dots$

The connections to the inputs D_A and D_B are

[Question ID = 52432]

1. $D_A = \bar{Q}_A, D_B = \bar{Q}_B$ [Option ID = 89722]
2. $D_A = (Q_A Q_B + \bar{Q}_A \bar{Q}_B), D_B = \bar{Q}_B$ [Option ID = 89720]
3. $D_A = (Q_A \bar{Q}_B + \bar{Q}_A Q_B), D_B = Q_A$ [Option ID = 89723]
4. $D_A = Q_B, D_B = Q_A$ [Option ID = 89721]

Correct Answer :-

- $D_A = (Q_A Q_B + \bar{Q}_A \bar{Q}_B), D_B = \bar{Q}_B$ [Option ID = 89720]

94)

In C language, what is the output of the following code

```
void main()
{
    int a, b=0;
    int c[10] = {1,2,3,4,5,6,7,8,9,10};
    for(a=0;a<10;++a)
        if(c[a]%2 == 0)
            b+=c[a];
    printf("%d", b);
}
```

[Question ID = 52394]

1. 24 [Option ID = 89569]
2. 30 [Option ID = 89570]
3. 20 [Option ID = 89568]
4. 25 [Option ID = 89571]

Correct Answer :-

- 30 [Option ID = 89570]

95)

If $\cot(\sin^{-1} \sqrt{1-x^2}) = \sin(\tan^{-1}(x\sqrt{6}))$, $x \neq 0$, then the possible value of x is

[Question ID = 52371]

1. $\frac{1}{2}$ [Option ID = 89476]
2. $\sqrt{\frac{1}{2}}$ [Option ID = 89478]
3. $\frac{1}{2} \sqrt{\frac{5}{3}}$ [Option ID = 89479]
4. $\frac{1}{2} \sqrt{\frac{2}{3}}$ [Option ID = 89477]

Correct Answer :-

- $\frac{1}{2} \sqrt{\frac{5}{3}}$ [Option ID = 89479]

96) A current $i(t) = \sin 2\pi t$ is applied to a capacitance of $C = 1 \mu\text{F}$. $v_c(t)$ at $t=1/4$ sec is

[Question ID = 52415]

1. $3.8 \times 10^4 \text{ V}$ [Option ID = 89655]
2. $15.9 \times 10^4 \text{ V}$ [Option ID = 89652]
3. $1.59 \times 10^4 \text{ V}$ [Option ID = 89653]
4. $4.2 \times 10^4 \text{ V}$ [Option ID = 89654]

Correct Answer :-

• $15.9 \times 10^4 \text{ V}$ [Option ID = 89652]

97) If the Newton Raphson Method is used to find the positive solution of the equation $f(x) = xe^{-x}$, the iteration equation is

[Question ID = 52372]

1. $x_n = \frac{x_{n-1}^2 - 2x_n}{x_{n-1} - 1}$ [Option ID = 89480]

2. $x_n = \frac{x_{n-1}^2}{x_{n-1} - 1}$ [Option ID = 89481]

3. $x_n = \frac{x_{n-1}^2 - x_{n-1} + 1}{x_{n-1}}$ [Option ID = 89483]

4. $x_n = \frac{x_{n-1}^2 + x_{n-1} - 1}{x_{n-1}}$ [Option ID = 89482]

Correct Answer :-

• $x_n = \frac{x_{n-1}^2}{x_{n-1} - 1}$ [Option ID = 89481]

98) One of the following is an indirect way of generating FM. This is the [Question ID = 52469]

1. Armstrong modulator [Option ID = 89871]
2. varactor diode modulator [Option ID = 89869]
3. reactance FET modulator [Option ID = 89868]
4. reactance bipolar transistor modulator [Option ID = 89870]

Correct Answer :-

- Armstrong modulator [Option ID = 89871]

99) A capacitor is charged by a constant current of 4 mA and results in a voltage increase of 12 V in a 10 sec interval. The value of capacitance is [Question ID = 52410]

1. 0.75 mF [Option ID = 89632]
2. 0.6 mF [Option ID = 89634]
3. 1.33 mF [Option ID = 89633]
4. 3.33 mF [Option ID = 89635]

Correct Answer :-

- 3.33 mF [Option ID = 89635]

100) The mode 1 of 8255 performs: [Question ID = 52437]

1. Simple I/P [Option ID = 89742]
2. Simple I/O [Option ID = 89740]
3. Bi-directional Data Transfer [Option ID = 89741]
4. Strobe I/O [Option ID = 89743]

Correct Answer :-

- Strobe I/O [Option ID = 89743]

