

National Testing Agency

Question Paper Name :	BTECH E 4th Sep 2020 Shift 2
Subject Name :	BTECH E
Creation Date :	2020-09-04 20:46:11
Duration :	180
Total Marks :	300
Display Marks:	Yes
Share Answer Key With Delivery Engine :	Yes
Actual Answer Key :	Yes

BTECH

Group Number :	1
Group Id :	405036123
Group Maximum Duration :	0
Group Minimum Duration :	180
Show Attended Group? :	No
Edit Attended Group? :	No
Break time :	0
Group Marks :	300
Is this Group for Examiner? :	No

Physics

Section Id :	405036409
Section Number :	1
Section type :	Online
Mandatory or Optional :	Mandatory
Number of Questions :	25
Number of Questions to be attempted :	25
Section Marks :	100
Display Number Panel :	Yes
Group All Questions :	Yes
Mark As Answered Required? :	Yes
Sub-Section Number :	1
Sub-Section Id :	405036785
Question Shuffling Allowed :	Yes



Question Number : 1 Question Id : 40503611231 Question Type : MCQ Option Shuffling : Yes Display Question Number : Yes Is Question Mandatory : No Single Line Question Option : No Option

Orientation : Vertical

Correct Marks : 4 Wrong Marks : 1

A quantity x is given by (Fv^2/WL^4) in terms of moment of inertia I , force F , velocity v , work W and Length L . The dimensional formula for x is same as that of :

Options :

40503640776. force constant

40503640777. energy density

40503640778. coefficient of viscosity

40503640779. planck's constant

Question Number : 1 Question Id : 40503611231 Question Type : MCQ Option Shuffling : Yes Display

Question Number : Yes Is Question Mandatory : No Single Line Question Option : No Option

Orientation : Vertical

Correct Marks : 4 Wrong Marks : 1

एक भौतिक मात्रा x का सूत्र (Fv^2/WL^4) है जहाँ, I जड़त्व आघूर्ण, F बल, v गति, W कार्य तथा L लम्बाई है। x के लिये विमीय सूत्र निम्न में से किसके समान है?

Options :

40503640776. बल स्थिरांक

40503640777. ऊर्जा घनत्व

40503640778. श्यानता गुणांक

40503640779. प्लांक स्थिरांक

Question Number : 2 Question Id : 40503611232 Question Type : MCQ Option Shuffling : Yes Display

Question Number : Yes Is Question Mandatory : No Single Line Question Option : No Option

Orientation : Vertical

Correct Marks : 4 Wrong Marks : 1



A small ball of mass m is thrown upward with velocity u from the ground. The ball experiences a resistive force mkv^2 where v is its speed. The maximum height attained by the ball is :

Options :

40503640780. $\frac{1}{k} \tan^{-1} \frac{ku^2}{2g}$

40503640781. $\frac{1}{2k} \tan^{-1} \frac{ku^2}{g}$

40503640782. $\frac{1}{2k} \ln \left(1 + \frac{ku^2}{g} \right)$

40503640783. $\frac{1}{k} \ln \left(1 + \frac{ku^2}{2g} \right)$

Question Number : 2 Question Id : 40503611232 Question Type : MCQ Option Shuffling : Yes Display Question Number : Yes Is Question Mandatory : No Single Line Question Option : No Option Orientation : Vertical

Correct Marks : 4 Wrong Marks : 1

द्रव्यमान m की एक छोटी गेंद को धरातल से ऊपर की ओर वेग u से फेंका जाता है। गेंद पर एक प्रतिरोधक बल mkv^2 (जहाँ v इसकी गति है) लग रहा है। यह गेंद कितनी अधिकतम ऊँचाई तक जायेगी ?

Options :

40503640780. $\frac{1}{k} \tan^{-1} \frac{ku^2}{2g}$

40503640781. $\frac{1}{2k} \tan^{-1} \frac{ku^2}{g}$

40503640782. $\frac{1}{2k} \ln \left(1 + \frac{ku^2}{g} \right)$

40503640783. $\frac{1}{k} \ln \left(1 + \frac{ku^2}{2g} \right)$

Question Number : 3 Question Id : 40503611233 Question Type : MCQ Option Shuffling : Yes Display Question Number : Yes Is Question Mandatory : No Single Line Question Option : No Option Orientation : Vertical

Correct Marks : 4 Wrong Marks : 1

A person pushes a box on a rough horizontal platform surface. He applies a force of 200 N over a distance of 15 m. Thereafter, he gets progressively tired and his applied force reduces linearly with distance to 100 N. The total distance through which the box has been moved is 30 m. What is the work done by the person during the total movement of the box ?

Options :

40503640784. 3280 J

40503640785. 5690 J

40503640786. 2780 J

40503640787. 5250 J

Question Number : 3 Question Id : 40503611233 Question Type : MCQ Option Shuffling : Yes Display Question Number : Yes Is Question Mandatory : No Single Line Question Option : No Option Orientation : Vertical

Correct Marks : 4 Wrong Marks : 1

एक व्यक्ति एक बक्से को एक क्षैतिज प्लेटफार्म की खुरदरी सतह पर धकेल रहा है। पहले 15 m तक व्यक्ति बक्से पर 200 N का बल लगाता है। तत्पश्चात् वह थक जाता है तथा उसके द्वारा लगाये जाने वाला बल बक्से द्वारा तय की गयी दूरी के साथ रेखीय रूप से कम होकर 100 N हो जाता है। यदि बक्से द्वारा तय की गयी कुल दूरी 30 m हो तो व्यक्ति द्वारा बक्से पर किये गये कुल कार्य का मान होगा :

Options :

40503640784. 3280 J

40503640785. 5690 J

40503640786. 2780 J

40503640787. 5250 J

Question Number : 4 Question Id : 40503611234 Question Type : MCQ Option Shuffling : Yes Display Question Number : Yes Is Question Mandatory : No Single Line Question Option : No Option Orientation : Vertical

Correct Marks : 4 Wrong Marks : 1

Consider two uniform discs of the same thickness and different radii $R_1 = R$ and $R_2 = \alpha R$ made of the same material. If the ratio of their moments of inertia I_1 and I_2 , respectively, about their axes is $I_1 : I_2 = 1 : 16$ then the value of α is :

Options :

40503640788. $2\sqrt{2}$

40503640789. 2

40503640790. 4

40503640791. $\sqrt{2}$



Question Number : 4 Question Id : 40503611234 Question Type : MCQ Option Shuffling : Yes Display

Question Number : Yes Is Question Mandatory : No Single Line Question Option : No Option Orientation : Vertical

Correct Marks : 4 Wrong Marks : 1

दो एक समान मोटाई की एक ही पदार्थ से बनी हुई डिस्कों पर विचार करें। इनकी त्रिज्याएँ $R_1 = R$ तथा $R_2 = \alpha R$ हैं। यदि इनके अक्ष के सापेक्ष इनके जड़त्व आघूर्ण क्रमशः I_1 और I_2 हैं और इनका अनुपात $I_1 : I_2 = 1 : 16$ है, तो α का मान होगा :

Options :

40503640788. $2\sqrt{2}$

40503640789. 2

40503640790. 4

40503640791. $\sqrt{2}$

Question Number : 5 Question Id : 40503611235 Question Type : MCQ Option Shuffling : Yes Display Question Number : Yes Is Question Mandatory : No Single Line Question Option : No Option Orientation : Vertical

Correct Marks : 4 Wrong Marks : 1

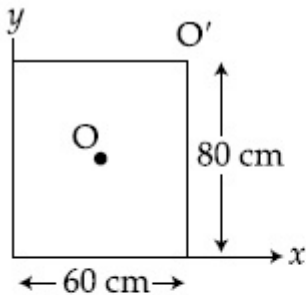

For a uniform rectangular sheet shown in the figure, the ratio of moments of inertia about the axes perpendicular to the sheet and passing through O (the centre of mass) and O' (corner point) is :

Options :

40503640792. $2/3$

40503640793. $1/2$

40503640794. $1/4$

40503640795. $1/8$

Question Number : 5 Question Id : 40503611235 Question Type : MCQ Option Shuffling : Yes Display

Question Number : Yes Is Question Mandatory : No Single Line Question Option : No Option

Orientation : Vertical

Correct Marks : 4 Wrong Marks : 1

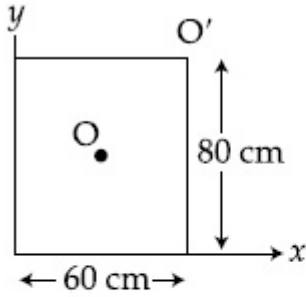

दिखाये गये चित्र में, एक समान आयताकार पटल के लिये O तथा O' से होकर जाने वाली अक्षों के सापेक्ष जड़त्व आघूर्ण का अनुपात है : (दोनों अक्ष पटल के लम्बवत हैं)

Options :

40503640792. $2/3$

40503640793. $1/2$

40503640794. $1/4$

40503640795. $1/8$

Question Number : 6 Question Id : 40503611236 Question Type : MCQ Option Shuffling : Yes Display

Question Number : Yes Is Question Mandatory : No Single Line Question Option : No Option

Orientation : Vertical

Correct Marks : 4 Wrong Marks : 1

A body is moving in a low circular orbit about a planet of mass M and radius R. The radius of the orbit can be taken to be R itself. Then the ratio of the speed of this body in the orbit to the escape velocity from the planet is :

Options :

40503640796. 1

40503640797. $\sqrt{2}$

40503640798. $\frac{1}{\sqrt{2}}$

40503640799. 2

Question Number : 6 Question Id : 40503611236 Question Type : MCQ Option Shuffling : Yes Display

Question Number : Yes Is Question Mandatory : No Single Line Question Option : No Option

Orientation : Vertical

Correct Marks : 4 Wrong Marks : 1

द्रव्यमान M और त्रिज्या R के एक ग्रह के चारों ओर एक नीची वृत्तीय कक्षा में एक वस्तु गतिशील है। कक्षा की त्रिज्या R ली जा सकती है। इस दशा में इस वस्तु की कक्षा में गति और ग्रह के पलायन वेग का अनुपात होगा :

Options :

40503640796. 1

40503640797. $\sqrt{2}$

40503640798. $\frac{1}{\sqrt{2}}$

40503640799. 2

Question Number : 7 Question Id : 40503611237 Question Type : MCQ Option Shuffling : Yes Display

Question Number : Yes Is Question Mandatory : No Single Line Question Option : No Option

Orientation : Vertical

Correct Marks : 4 Wrong Marks : 1

A cube of metal is subjected to a hydrostatic pressure of 4 GPa. The percentage change in the length of the side of the cube is close to :

(Given bulk modulus of metal,
 $B = 8 \times 10^{10}$ Pa)

Options :

40503640800. 20

40503640801. 0.6

40503640802. 1.67

40503640803. 5

Question Number : 7 Question Id : 40503611237 Question Type : MCQ Option Shuffling : Yes Display Question Number : Yes Is Question Mandatory : No Single Line Question Option : No Option Orientation : Vertical

Correct Marks : 4 Wrong Marks : 1

धातु के एक घनाकार टुकड़े पर 4 GPa का द्रवस्थैतिक (hydrostatic) दाब लगाया जाता है। घन की कोर की लम्बाई में प्रतिशत बदलाव (percentage change) का सन्निकट मान होगा :

(दिया है : धातु का आयतन प्रत्यास्थता गुणांक
 $B = 8 \times 10^{10}$ Pa)

Options :

40503640800. 20

40503640801. 0.6

40503640802. 1.67

40503640803. 5

Question Number : 8 Question Id : 40503611238 Question Type : MCQ Option Shuffling : Yes Display Question Number : Yes Is Question Mandatory : No Single Line Question Option : No Option Orientation : Vertical

Correct Marks : 4 Wrong Marks : 1

Two identical cylindrical vessels are kept on the ground and each contain the same liquid of density d . The area of the base of both vessels is S but the height of liquid in one vessel is x_1 and in the other, x_2 . When both cylinders are connected through a pipe of negligible volume very close to the bottom, the liquid flows from one vessel to the other until it comes to equilibrium at a new height. The change in energy of the system in the process is :

Options :

40503640804. $\frac{3}{4} gdS (x_2 - x_1)^2$

40503640805. $gdS (x_2^2 + x_1^2)$

40503640806. $gdS (x_2 + x_1)^2$

40503640807. $\frac{1}{4} gdS (x_2 - x_1)^2$

Question Number : 8 Question Id : 40503611238 Question Type : MCQ Option Shuffling : Yes Display Question Number : Yes Is Question Mandatory : No Single Line Question Option : No Option Orientation : Vertical

Correct Marks : 4 Wrong Marks : 1

दो एकसमान बेलनाकार बर्तन धरती पर रखे हैं और इनमें घनत्व d का द्रव भरा हुआ है। दोनों बर्तनों के आधारों का क्षेत्रफल S हैं परन्तु एक बर्तन में द्रव की ऊँचाई x_1 है और दूसरे में x_2 है। जब दोनों बेलनों को उनकी पेंदी के समीप नगण्य आयतन के एक पाइप द्वारा जोड़ दिया जाता है तब एक बर्तन से द्रव प्रवाहित होकर दूसरे बर्तन में तब तक जाता है जब तक कि एक नई ऊँचाई पर साम्यावस्था न आये। इस प्रक्रिया में निकाय में हुई ऊर्जा में परिवर्तन है :

Options :

40503640804. $\frac{3}{4} \text{gdS } (x_2 - x_1)^2$

40503640805. $\text{gdS } (x_2^2 + x_1^2)$

40503640806. $\text{gdS } (x_2 + x_1)^2$

40503640807. $\frac{1}{4} \text{gdS } (x_2 - x_1)^2$

Question Number : 9 Question Id : 40503611239 Question Type : MCQ Option Shuffling : Yes Display Question Number : Yes Is Question Mandatory : No Single Line Question Option : No Option Orientation : Vertical

Correct Marks : 4 Wrong Marks : 1

Match the thermodynamic processes taking place in a system with the correct conditions. In the table : ΔQ is the heat supplied, ΔW is the work done and ΔU is change in internal energy of the system.

Process	Condition
(I) Adiabatic	(A) $\Delta W = 0$
(II) Isothermal	(B) $\Delta Q = 0$
(III) Isochoric	(C) $\Delta U \neq 0, \Delta W \neq 0,$ $\Delta Q \neq 0$
(IV) Isobaric	(D) $\Delta U = 0$

Options :

40503640808. (I) - (B), (II) - (A), (III) - (D), (IV) - (C)

40503640809. (I) - (B), (II) - (D), (III) - (A), (IV) - (C)

40503640810. (I) - (A), (II) - (A), (III) - (B), (IV) - (C)

40503640811. (I) - (A), (II) - (B), (III) - (D), (IV) - (D)



Question Number : 9 Question Id : 40503611239 Question Type : MCQ Option Shuffling : Yes Display

Question Number : Yes Is Question Mandatory : No Single Line Question Option : No Option
Orientation : Vertical

Correct Marks : 4 Wrong Marks : 1

दी गयी सारिणी में एक निकाय पर होने वाले ऊष्मागतिक प्रक्रियाओं की दी गयी अवस्थाओं से मेल करिये। यहाँ ΔQ निकाय को दी जाने वाली ऊष्मा, ΔW किया गया कार्य तथा ΔU निकाय की आंतरिक ऊर्जा में परिवर्तन दर्शाते हैं।

प्रक्रिया	अवस्था
(I) रुद्धोष्म	(A) $\Delta W = 0$
(II) समतापिय	(B) $\Delta Q = 0$
(III) समआयतनिक	(C) $\Delta U \neq 0, \Delta W \neq 0,$ $\Delta Q \neq 0$
(IV) समदाबी	(D) $\Delta U = 0$

Options :

40503640808. (I) - (B), (II) - (A), (III) - (D), (IV) - (C)

40503640809. (I) - (B), (II) - (D), (III) - (A), (IV) - (C)

40503640810. (I) - (A), (II) - (A), (III) - (B), (IV) - (C)

40503640811. (I) - (A), (II) - (B), (III) - (D), (IV) - (D)

Question Number : 10 Question Id : 40503611240 Question Type : MCQ Option Shuffling : Yes
Display Question Number : Yes Is Question Mandatory : No Single Line Question Option : No Option
Orientation : Vertical

Correct Marks : 4 Wrong Marks : 1

The driver of a bus approaching a big wall notices that the frequency of his bus's horn changes from 420 Hz to 490 Hz when he hears it after it gets reflected from the wall. Find the speed of the bus if speed of the sound is 330 ms^{-1} .

Options :

40503640812. 71 kmh^{-1}

40503640813. 81 kmh^{-1}

40503640814. 91 kmh^{-1}

40503640815. 61 kmh^{-1}

Question Number : 10 Question Id : 40503611240 Question Type : MCQ Option Shuffling : Yes Display Question Number : Yes Is Question Mandatory : No Single Line Question Option : No Option Orientation : Vertical

Correct Marks : 4 Wrong Marks : 1

एक बस चालक का ध्यान इस ओर जाता है कि जब यह बस एक बड़ी दीवार की ओर चल रही हैं तो इसके हॉर्न की ध्वनि की आवृत्ति, जो 420 Hz है, दीवार से परावर्तित होकर चालक को 490 Hz की सुनाई पड़ती है। यदि ध्वनि की गति 330 ms^{-1} हो तो बस की गति है :

Options :

40503640812. 71 kmh^{-1}

40503640813. 81 kmh^{-1}

40503640814. 91 kmh^{-1}

40503640815. 61 kmh^{-1}

Question Number : 11 Question Id : 40503611241 Question Type : MCQ Option Shuffling : Yes Display Question Number : Yes Is Question Mandatory : No Single Line Question Option : No Option Orientation : Vertical

Correct Marks : 4 Wrong Marks : 1

A particle of charge q and mass m is subjected to an electric field $E = E_0(1 - ax^2)$ in the x -direction, where a and E_0 are constants. Initially the particle was at rest at $x = 0$. Other than the initial position the kinetic energy of the particle becomes zero when the distance of the particle from the origin is :

Options :

40503640816. a

40503640817. $\sqrt{\frac{1}{a}}$

40503640818. $\sqrt{\frac{2}{a}}$

40503640819. $\sqrt{\frac{3}{a}}$

Question Number : 11 Question Id : 40503611241 Question Type : MCQ Option Shuffling : Yes Display Question Number : Yes Is Question Mandatory : No Single Line Question Option : No Option Orientation : Vertical

Correct Marks : 4 Wrong Marks : 1

द्रव्यमान m तथा आवेश q का एक कण पर एक विद्युत क्षेत्र $E(x) = E_0(1 - ax^2)$, जो x - दिशा में है, लगाया जाता है। यहाँ पर a तथा E_0 स्थिरांक है। आरम्भ में कण $x = 0$ पर विरामावस्था में है। प्रारम्भिक अवस्था के अतिरिक्त मूल बिन्दु से कण की किस दूरी पर कण की गतिज ऊर्जा शून्य होगी ?

Options :

40503640816. a

40503640817. $\sqrt{\frac{1}{a}}$

40503640818. $\sqrt{\frac{2}{a}}$

40503640819. $\sqrt{\frac{3}{a}}$



Question Number : 12 Question Id : 40503611242 Question Type : MCQ Option Shuffling : Yes Display Question Number : Yes Is Question Mandatory : No Single Line Question Option : No Option Orientation : Vertical

Correct Marks : 4 Wrong Marks : 1

A capacitor C is fully charged with voltage V_0 . After disconnecting the voltage source, it is connected in parallel with another uncharged capacitor of capacitance $\frac{C}{2}$. The energy loss in the process after the charge is distributed between the two capacitors is :

Options :

40503640820. $\frac{1}{2} CV_0^2$

40503640821. $\frac{1}{3} CV_0^2$

40503640822. $\frac{1}{4} CV_0^2$

40503640823. $\frac{1}{6} CV_0^2$

Question Number : 12 Question Id : 40503611242 Question Type : MCQ Option Shuffling : Yes
Display Question Number : Yes Is Question Mandatory : No Single Line Question Option : No Option
Orientation : Vertical

Correct Marks : 4 Wrong Marks : 1

एक धारिता C के संधारित्र को विभव V_0 से आवेशित करके एक दूसरे $\frac{C}{2}$ धारिता के अनावेशित संधारित्र से समांतर क्रम में जोड़ा जाता है। जब आवेश दोनों संधारित्रों में वितरित हो जाता है, तो इस प्रक्रम में क्षयित ऊर्जा का मान होगा :

Options :

40503640820. $\frac{1}{2} CV_0^2$

40503640821. $\frac{1}{3} CV_0^2$

40503640822. $\frac{1}{4} CV_0^2$

40503640823. $\frac{1}{6} CV_0^2$

Question Number : 13 Question Id : 40503611243 Question Type : MCQ Option Shuffling : Yes Display Question Number : Yes Is Question Mandatory : No Single Line Question Option : No Option Orientation : Vertical

Correct Marks : 4 Wrong Marks : 1

A circular coil has moment of inertia 0.8 kg m^2 around any diameter and is carrying current to produce a magnetic moment of 20 Am^2 . The coil is kept initially in a vertical position and it can rotate freely around a horizontal diameter. When a uniform magnetic field of 4 T is applied along the vertical, it starts rotating around its horizontal diameter. The angular speed the coil acquires after rotating by 60° will be :

Options :

40503640824. 20 rad s^{-1}

40503640825. 10 rad s^{-1}

40503640826. $20 \pi \text{ rad s}^{-1}$

40503640827. $10 \pi \text{ rad s}^{-1}$

Question Number : 13 Question Id : 40503611243 Question Type : MCQ Option Shuffling : Yes Display Question Number : Yes Is Question Mandatory : No Single Line Question Option : No Option Orientation : Vertical

Correct Marks : 4 Wrong Marks : 1



एक वृत्ताकार कुंडली का इसके व्यास के सापेक्ष जड़त्व आघूर्ण 0.8 kg m^2 है और इसमें बहने वाली विद्युत धारा के कारण इसका चुम्बकीय आघूर्ण 20 Am^2 है। यह कुंडली इसके क्षैतिज व्यास के चारों ओर स्वतन्त्र रूप से घूम सकती है और आरम्भ में इसे ऊर्ध्वाधर अवस्था में रखा गया है। जब इस पर एक 4 T मान का एक समान चुम्बकीय क्षेत्र ऊर्ध्वाधर दिशा में लगाया जाता है, तो यह अपने क्षैतिज व्यास के चारों ओर घूमने लगती है। 60° कोण से घूमने पर कुंडली का कोणीय वेग होगा :

Options :

40503640824. 20 rad s^{-1}
40503640825. 10 rad s^{-1}
40503640826. $20 \pi \text{ rad s}^{-1}$
40503640827. $10 \pi \text{ rad s}^{-1}$

Question Number : 14 Question Id : 40503611244 Question Type : MCQ Option Shuffling : Yes Display Question Number : Yes Is Question Mandatory : No Single Line Question Option : No Option Orientation : Vertical

Correct Marks : 4 Wrong Marks : 1

A paramagnetic sample shows a net magnetisation of 6 A/m when it is placed in an external magnetic field of 0.4 T at a temperature of 4 K . When the sample is placed in an external magnetic field of 0.3 T at a temperature of 24 K , then the magnetisation will be :

Options :

40503640828. 4 A/m
40503640829. 2.25 A/m
40503640830. 1 A/m

40503640831. 0.75 A/m

Question Number : 14 Question Id : 40503611244 Question Type : MCQ Option Shuffling : Yes Display Question Number : Yes Is Question Mandatory : No Single Line Question Option : No Option Orientation : Vertical

Correct Marks : 4 Wrong Marks : 1

जब अनुचुम्बकीय पदार्थ से बने एक नमूने को 4 K तापमान पर 0.4 T मान के बाहरी चुम्बकीय क्षेत्र में रखा जाता है, तो इस पर उत्पन्न चुंबकन का मान 6 Am^{-1} है। यदि इसी नमूने को 24 K तापमान पर 0.3 T मान के चुम्बकीय क्षेत्र में रखा जाय तो इसमें उत्पन्न चुंबकन का मान होगा :

Options :

40503640828. 4 A/m

40503640829. 2.25 A/m

40503640830. 1 A/m

40503640831. 0.75 A/m

Question Number : 15 Question Id : 40503611245 Question Type : MCQ Option Shuffling : Yes Display Question Number : Yes Is Question Mandatory : No Single Line Question Option : No Option Orientation : Vertical

Correct Marks : 4 Wrong Marks : 1

A series L-R circuit is connected to a battery of emf V . If the circuit is switched on at $t=0$, then the time at which the energy

stored in the inductor reaches $\left(\frac{1}{n}\right)$ times

of its maximum value, is :

Options :

40503640832. $\frac{L}{R} \ln\left(\frac{\sqrt{n}-1}{\sqrt{n}}\right)$

40503640833. $\frac{L}{R} \ln\left(\frac{\sqrt{n}+1}{\sqrt{n}-1}\right)$

40503640834. $\frac{L}{R} \ln\left(\frac{\sqrt{n}}{\sqrt{n}-1}\right)$

40503640835. $\frac{L}{R} \ln\left(\frac{\sqrt{n}}{\sqrt{n}+1}\right)$

Question Number : 15 Question Id : 40503611245 Question Type : MCQ Option Shuffling : Yes Display Question Number : Yes Is Question Mandatory : No Single Line Question Option : No Option Orientation : Vertical Correct Marks : 4 Wrong Marks : 1

एक श्रेणीबद्ध L-R परिपथ को विद्युत वाहक बल V की एक बैटरी से जोड़ा जाता है। यदि समय $t=0$ पर इसके स्विच को ऑन करा जाय तो उस समय का मान, जब इसके प्रेरक में संचित ऊर्जा अपने

अधिकतम मान की $\left(\frac{1}{n}\right)$ पहुँचे होगा :

Options :

40503640832. $\frac{L}{R} \ln\left(\frac{\sqrt{n}-1}{\sqrt{n}}\right)$

40503640833. $\frac{L}{R} \ln\left(\frac{\sqrt{n}+1}{\sqrt{n}-1}\right)$

40503640834. $\frac{L}{R} \ln\left(\frac{\sqrt{n}}{\sqrt{n}-1}\right)$

40503640835. $\frac{L}{R} \ln\left(\frac{\sqrt{n}}{\sqrt{n}+1}\right)$

Question Number : 16 Question Id : 40503611246 Question Type : MCQ Option Shuffling : Yes Display Question Number : Yes Is Question Mandatory : No Single Line Question Option : No Option Orientation : Vertical Correct Marks : 4 Wrong Marks : 1



The electric field of a plane electromagnetic wave is given by

$$\vec{E} = E_0 (\hat{x} + \hat{y}) \sin(kz - \omega t)$$

Its magnetic field will be given by :

Options :

40503640836. $\frac{E_0}{c} (\hat{x} + \hat{y}) \sin(kz - \omega t)$

40503640837. $\frac{E_0}{c} (\hat{x} - \hat{y}) \sin(kz - \omega t)$

40503640838. $\frac{E_0}{c} (-\hat{x} + \hat{y}) \sin(kz - \omega t)$

40503640839. $\frac{E_0}{c} (\hat{x} - \hat{y}) \cos(kz - \omega t)$

Question Number : 16 Question Id : 40503611246 Question Type : MCQ Option Shuffling : Yes
Display Question Number : Yes Is Question Mandatory : No Single Line Question Option : No Option
Orientation : Vertical

Correct Marks : 4 Wrong Marks : 1

एक समतल विद्युत-चुम्बकीय तरंग के विद्युत क्षेत्र

$\vec{E} = E_0 (\hat{x} + \hat{y}) \sin(kz - \omega t)$ है। इसका चुम्बकीय

क्षेत्र होगा :

Options :

40503640836. $\frac{E_0}{c} (\hat{x} + \hat{y}) \sin(kz - \omega t)$

40503640837. $\frac{E_0}{c} (\hat{x} - \hat{y}) \sin(kz - \omega t)$

40503640838. $\frac{E_0}{c} (-\hat{x} + \hat{y}) \sin(kz - \omega t)$

$$40503640839. \frac{E_0}{c} (\hat{x} - \hat{y}) \cos(kz - \omega t)$$

Question Number : 17 Question Id : 40503611247 Question Type : MCQ Option Shuffling : Yes Display Question Number : Yes Is Question Mandatory : No Single Line Question Option : No Option Orientation : Vertical

Correct Marks : 4 Wrong Marks : 1

In a photoelectric effect experiment, the graph of stopping potential V versus reciprocal of wavelength obtained is shown in the figure. As the intensity of incident radiation is increased :

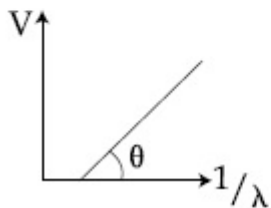

Options :

40503640840. Graph does not change
40503640841. Straight line shifts to left
40503640842. Straight line shifts to right
40503640843. Slope of the straight line get more steep

Question Number : 17 Question Id : 40503611247 Question Type : MCQ Option Shuffling : Yes Display Question Number : Yes Is Question Mandatory : No Single Line Question Option : No Option Orientation : Vertical

Correct Marks : 4 Wrong Marks : 1

प्रकाश विद्युत प्रभाव के एक प्रयोग के लिये निरोधी विभव का तरंगदैर्घ्य के व्युत्क्रम के साथ विचरण चित्र में बने ग्राफ से दर्शाया गया है। यदि प्रयोग में आपाती विकिरण की तीव्रता बढ़ाई जाय तो :

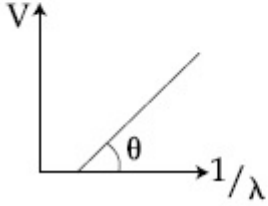

Options :

40503640840. ग्राफ नहीं बदलेगा।
40503640841. ग्राफ में दिखायी गयी सीधी रेखा बाँयी ओर विस्थापित हो जायेगी।
40503640842. ग्राफ में दिखायी गयी सीधी रेखा दाँयी ओर विस्थापित हो जायेगी।
40503640843. दिखायी गयी सीधी रेखा का ढाल माप बढ़ जायेगा।

Question Number : 18 Question Id : 40503611248 Question Type : MCQ Option Shuffling : Yes Display Question Number : Yes Is Question Mandatory : No Single Line Question Option : No Option Orientation : Vertical

Correct Marks : 4 Wrong Marks : 1

Find the Binding energy per nucleon for

$^{120}_{50}\text{Sn}$. Mass of proton $m_p = 1.00783 \text{ U}$, mass of neutron $m_n = 1.00867 \text{ U}$ and mass of tin nucleus $m_{\text{Sn}} = 119.902199 \text{ U}$. (take $1\text{U} = 931 \text{ MeV}$)

Options :

40503640844. 8.0 MeV
40503640845. 7.5 MeV
40503640846. 8.5 MeV
40503640847. 9.0 MeV

Question Number : 18 Question Id : 40503611248 Question Type : MCQ Option Shuffling : Yes
Display Question Number : Yes Is Question Mandatory : No Single Line Question Option : No Option
Orientation : Vertical

Correct Marks : 4 Wrong Marks : 1

टिन के नाभिक ${}_{50}^{120}\text{Sn}$ के लिये प्रति न्यूक्लियॉन बंधन ऊर्जा कितनी होगी? यह दिया हुआ है कि प्रोटॉन का द्रव्यमान $m_p = 1.00783 \text{ U}$, न्यूट्रॉन का द्रव्यमान $m_n = 1.00867 \text{ U}$ और टिन के नाभिक का द्रव्यमान $m_{\text{Sn}} = 119.902199 \text{ U}$
($1\text{U} = 931 \text{ MeV}$ लें)

Options :

40503640844. 8.0 MeV

40503640845. 7.5 MeV

40503640846. 8.5 MeV

40503640847. 9.0 MeV

Question Number : 19 Question Id : 40503611249 Question Type : MCQ Option Shuffling : Yes
Display Question Number : Yes Is Question Mandatory : No Single Line Question Option : No Option
Orientation : Vertical

Correct Marks : 4 Wrong Marks : 1

Identify the operation performed by the circuit given below :

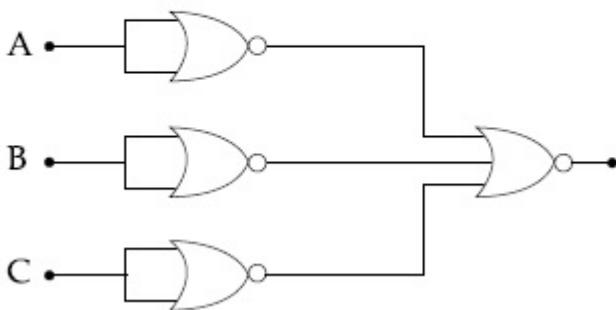

Options :

40503640848. NOT

40503640849. AND

40503640850. OR

40503640851. NAND

Question Number : 19 Question Id : 40503611249 Question Type : MCQ Option Shuffling : Yes Display Question Number : Yes Is Question Mandatory : No Single Line Question Option : No Option Orientation : Vertical

Correct Marks : 4 Wrong Marks : 1

निचे दिये गये परिपथ के द्वारा किये जाने वाली संक्रिया (operation) की पहचान करें :

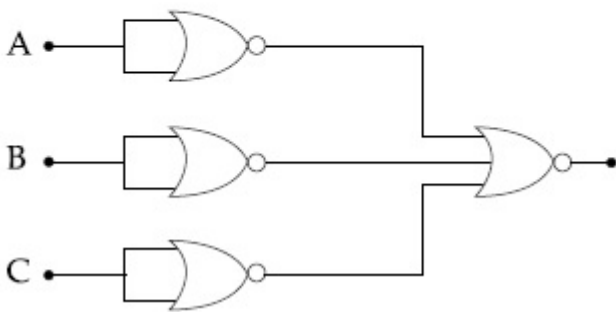

Options :

40503640848. NOT

40503640849. AND

40503640850. OR

40503640851. NAND

Question Number : 20 Question Id : 40503611250 Question Type : MCQ Option Shuffling : Yes Display Question Number : Yes Is Question Mandatory : No Single Line Question Option : No Option Orientation : Vertical

Correct Marks : 4 Wrong Marks : 1

The value of current i_1 flowing from A to C in the circuit diagram is :

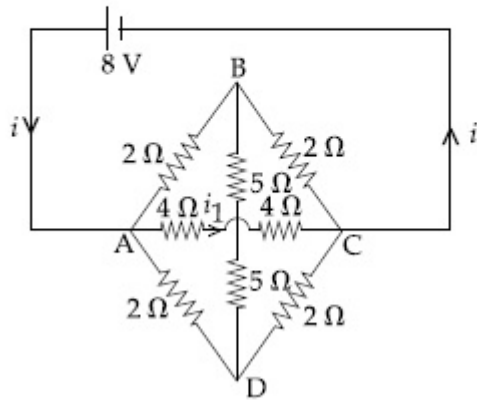

Options :

40503640852. 1 A

40503640853. 2 A

40503640854. 4 A

40503640855. 5 A

Question Number : 20 Question Id : 40503611250 Question Type : MCQ Option Shuffling : Yes Display Question Number : Yes Is Question Mandatory : No Single Line Question Option : No Option Orientation : Vertical

Correct Marks : 4 Wrong Marks : 1

दिये गये परिपथ में A से C की ओर बहने वाली विद्युत धारा i_1 का मान होगा :

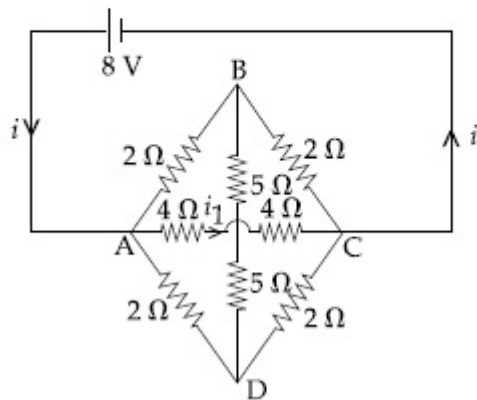

Options :

40503640852. 1 A

40503640853. 2 A

40503640854. 4 A

40503640855. 5 A

Sub-Section Number :

2

Sub-Section Id :

405036786

Question Shuffling Allowed :

Yes

Question Number : 21 Question Id : 40503611251 Question Type : SA Display Question Number : Yes

Correct Marks : 4 Wrong Marks : 0

The speed versus time graph for a particle is shown in the figure. The distance travelled (in m) by the particle during the time interval $t=0$ to $t=5$ s will be

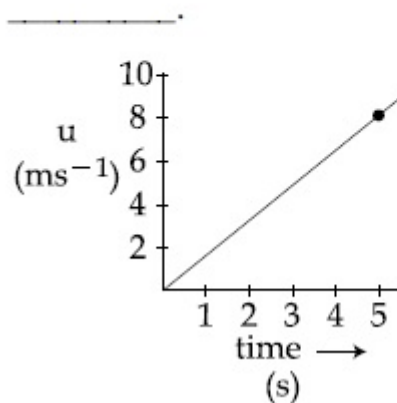

Response Type : Numeric

Evaluation Required For SA : Yes

Show Word Count : Yes

Answers Type : Range

Text Areas : PlainText

Possible Answers :

5 to 5.002

Question Number : 21 Question Id : 40503611251 Question Type : SA Display Question Number : Yes

Correct Marks : 4 Wrong Marks : 0

दिये गये ग्राफ में एक कण की गति का समय के साथ होने वाला परिवर्तन दिखाया गया है। समय अन्तराल $t=0$ से $t=5\text{ s}$ में इस कण द्वारा चली गई दूरी (मीटर में) का मान होगा _____।

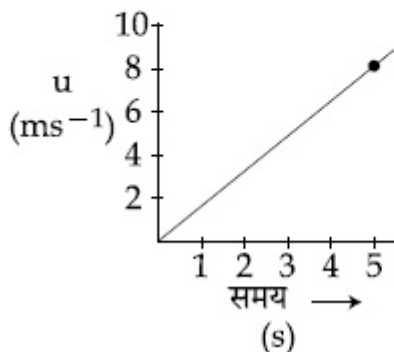

Response Type : Numeric

Evaluation Required For SA : Yes

Show Word Count : Yes

Answers Type : Range

Text Areas : PlainText

Possible Answers :

5 to 5.002

Question Number : 22 **Question Id :** 40503611252 **Question Type :** SA **Display Question Number :** Yes

Correct Marks : 4 **Wrong Marks :** 0

The change in the magnitude of the volume of an ideal gas when a small additional pressure ΔP is applied at a constant temperature, is the same as the change when the temperature is reduced by a small quantity ΔT at constant pressure. The initial temperature and pressure of the gas were 300 K and 2 atm. respectively. If $|\Delta T|=C|\Delta P|$ then value of C in (K/atm.) is _____.

Response Type : Numeric

Evaluation Required For SA : Yes

Show Word Count : Yes

Answers Type : Range

Text Areas : PlainText

Possible Answers :

5 to 5.002

Question Number : 22 Question Id : 40503611252 Question Type : SA Display Question Number : Yes
Correct Marks : 4 Wrong Marks : 0

एक आदर्श गैस पर स्थिर तापमान पर थोड़ा सा अतिरिक्त दबाव ΔP लगाने पर इसके आयतन में होने वाला परिवर्तन उतना ही है, जब इस गैस का तापमान स्थिर दबाव पर थोड़ा सा (ΔT) कम करा जाता है। गैस के आरम्भिक तापमान व दबाव क्रमशः 300 K और 2 वायुमंडलीय दबाव (atmospheric pressure) के बराबर है। यदि $|\Delta T| = C|\Delta P|$ हो, तो C का मान (K/वायुमंडल दाब में) होगा _____।

Response Type : Numeric

Evaluation Required For SA : Yes

Show Word Count : Yes

Answers Type : Range

Text Areas : PlainText

Possible Answers :

5 to 5.002

Question Number : 23 Question Id : 40503611253 Question Type : SA Display Question Number : Yes
Correct Marks : 4 Wrong Marks : 0

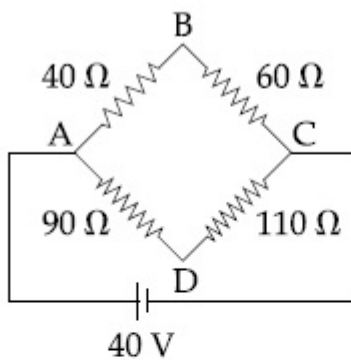

Four resistances 40Ω , 60Ω , 90Ω and 110Ω make the arms of a quadrilateral ABCD. Across AC is a battery of emf 40 V and internal resistance negligible. The potential difference across BD in V is _____.

Response Type : Numeric

Evaluation Required For SA : Yes

Show Word Count : Yes

Answers Type : Range

Text Areas : PlainText

Possible Answers :

5 to 5.002

Question Number : 23 Question Id : 40503611253 Question Type : SA Display Question Number : Yes
Correct Marks : 4 Wrong Marks : 0

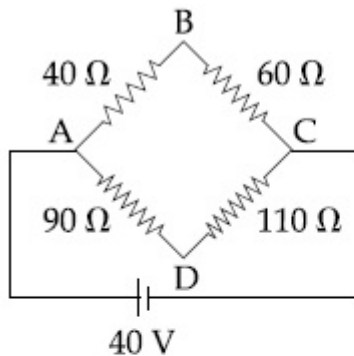

चार प्रतिरोधक जिनके प्रतिरोध 40Ω , 60Ω , 90Ω और 110Ω है, एक चतुर्भुज ABCD के आकार में जोड़े गये हैं (चित्र देखें) AC पर एक बैटरी लगी हुई है जिसका विद्युत-वाहक बल $40 V$ तथा आंतरिक प्रतिरोध शून्य है। B और D के बीच विभवान्तर (वोल्ट में) होगा _____।

Response Type : Numeric

Evaluation Required For SA : Yes

Show Word Count : Yes

Answers Type : Range

Text Areas : PlainText

Possible Answers :

5 to 5.002

Question Number : 24 Question Id : 40503611254 Question Type : SA Display Question Number : Yes
Correct Marks : 4 Wrong Marks : 0

The distance between an object and a screen is 100 cm . A lens can produce real image of the object on the screen for two different positions between the screen and the object. The distance between these two positions is 40 cm . If the power of the lens is close to $\left(\frac{N}{100}\right)D$ where N is an integer, the value of N is _____.

Response Type : Numeric

Evaluation Required For SA : Yes

Show Word Count : Yes

Answers Type : Range

Text Areas : PlainText

Possible Answers :

5 to 5.002

Question Number : 24 **Question Id :** 40503611254 **Question Type :** SA Display **Question Number :** Yes

Correct Marks : 4 **Wrong Marks :** 0

एक वस्तु और एक पर्दे के बीच की दूरी 100 cm है। वस्तु और पर्दे के बीच दो भिन्न स्थानों पर रखे जाने पर एक लेन्स इस वस्तु का पर्दे पर वास्तविक प्रतिबिम्ब बनाता है। इन दो स्थानों के बीच की दूरी 40 cm है।

यदि लेन्स की शक्ति लगभग $\left(\frac{N}{100}\right)D$ हो (N एक पूर्णांक है) तो N का मान है _____।

Response Type : Numeric

Evaluation Required For SA : Yes

Show Word Count : Yes

Answers Type : Range

Text Areas : PlainText

Possible Answers :

5 to 5.002

Question Number : 25 **Question Id :** 40503611255 **Question Type :** SA Display **Question Number :** Yes

Correct Marks : 4 **Wrong Marks :** 0

Orange light of wavelength 6000×10^{-10} m illuminates a single slit of width 0.6×10^{-4} m. The maximum possible number of diffraction minima produced on both sides of the central maximum is _____.

Response Type : Numeric

Evaluation Required For SA : Yes

Show Word Count : Yes

Answers Type : Range

Text Areas : PlainText

Possible Answers :

5 to 5.002

Question Number : 25 Question Id : 40503611255 Question Type : SA Display Question Number : Yes Correct Marks : 4 Wrong Marks : 0

तरंगदैर्घ्य 6000×10^{-10} m का नारंगी प्रकाश एक झिरी, जिसकी चौड़ाई 0.6×10^{-4} m है, को प्रकाशमान कर रहा है। इससे बनने वाले केन्द्रीय महत्तम के दोनों ओर विवर्तन चित्र में सम्भावित अधिकतम कितने विवर्तन के न्यूनतम (diffraction minima) होंगे _____।

Response Type : Numeric

Evaluation Required For SA : Yes

Show Word Count : Yes

Answers Type : Range

Text Areas : PlainText

Possible Answers :

5 to 5.002

Chemistry

Section Id :	405036410
Section Number :	2
Section type :	Online
Mandatory or Optional :	Mandatory
Number of Questions :	25
Number of Questions to be attempted :	25
Section Marks :	100
Display Number Panel :	Yes
Group All Questions :	Yes
Mark As Answered Required? :	Yes
Sub-Section Number :	1
Sub-Section Id :	405036787
Question Shuffling Allowed :	Yes

Question Number : 26 Question Id : 40503611256 Question Type : MCQ Option Shuffling : Yes Display Question Number : Yes Is Question Mandatory : No Single Line Question Option : No Option Orientation : Vertical

Correct Marks : 4 Wrong Marks : 1

A sample of red ink (a colloidal suspension) is prepared by mixing eosin dye, egg white, HCHO and water. The component which ensures stability of the ink sample is :

Options :

40503640861. Eosin dye
40503640862. Egg white
40503640863. HCHO
40503640864. Water

**Question Number : 26 Question Id : 40503611256 Question Type : MCQ Option Shuffling : Yes
Display Question Number : Yes Is Question Mandatory : No Single Line Question Option : No Option
Orientation : Vertical**

Correct Marks : 4 Wrong Marks : 1

लाल स्याही (एक कोलाइडी निलंबन) के एक प्रतिदर्श को इओसिन रंजक, अंडे का सफेद भाग, HCHO तथा जल को मिश्रित करके बनाया जाता है। स्याही प्रतिदर्श के स्थायित्व को सुनिश्चित करने वाला जो घटक है, वह है :

Options :

40503640861. इओसिन रंजक
40503640862. अंडे का सफेद भाग
40503640863. HCHO
40503640864. जल

**Question Number : 27 Question Id : 40503611257 Question Type : MCQ Option Shuffling : Yes
Display Question Number : Yes Is Question Mandatory : No Single Line Question Option : No Option
Orientation : Vertical**

Correct Marks : 4 Wrong Marks : 1

250 mL of a waste solution obtained from the workshop of a goldsmith contains 0.1 M AgNO_3 and 0.1 M AuCl . The solution was electrolyzed at 2 V by passing a current of 1 A for 15 minutes. The metal/metals electrodeposited will be :

$$\left(E^0_{\text{Ag}^+/\text{Ag}} = 0.80 \text{ V}, E^0_{\text{Au}^+/\text{Au}} = 1.69 \text{ V} \right)$$

Options :

40503640865. only silver
40503640866. silver and gold in equal mass proportion
40503640867. silver and gold in proportion to their atomic weights
40503640868. only gold

Question Number : 27 Question Id : 40503611257 Question Type : MCQ Option Shuffling : Yes Display Question Number : Yes Is Question Mandatory : No Single Line Question Option : No Option Orientation : Vertical

Correct Marks : 4 Wrong Marks : 1

एक सुनार की कार्यशाला से प्राप्त एक अपशिष्ट विलयन के 250 mL में 0.1 M AgNO_3 तथा 0.1 M AuCl हैं। इस विलयन को 2 V पर एक 1 A की विद्युत धारा 15 मिनट तक प्रवाहित करके वैद्युत अपघटित किया गया। धातु/ धातुएँ जो वैद्युत निक्षेपित होंगी/होंगे, है/हैं :

$$\left(E^0_{\text{Ag}^+/\text{Ag}} = 0.80 \text{ V}, E^0_{\text{Au}^+/\text{Au}} = 1.69 \text{ V} \right)$$

Options :

40503640865. मात्र चांदी
40503640866. चांदी तथा सोना समान संहति के समानुपात में

चांदी तथा सोना, उनके परमाणु भार के समानुपात

40503640867. में

40503640868. मात्र सोना

Question Number : 28 Question Id : 40503611258 Question Type : MCQ Option Shuffling : Yes Display Question Number : Yes Is Question Mandatory : No Single Line Question Option : No Option Orientation : Vertical

Correct Marks : 4 Wrong Marks : 1

If the equilibrium constant for $A \rightleftharpoons B + C$ is $K_{eq}^{(1)}$ and that of $B + C \rightleftharpoons P$ is $K_{eq}^{(2)}$, the equilibrium constant for $A \rightleftharpoons P$ is :

Options :

40503640869. $K_{eq}^{(1)} + K_{eq}^{(2)}$

40503640870. $K_{eq}^{(1)} / K_{eq}^{(2)}$

40503640871. $K_{eq}^{(1)} K_{eq}^{(2)}$

40503640872. $K_{eq}^{(2)} - K_{eq}^{(1)}$

Question Number : 28 Question Id : 40503611258 Question Type : MCQ Option Shuffling : Yes Display Question Number : Yes Is Question Mandatory : No Single Line Question Option : No Option Orientation : Vertical

Correct Marks : 4 Wrong Marks : 1

यदि $A \rightleftharpoons B + C$ के लिए साम्य स्थिरांक $K_{eq}^{(1)}$

तथा $B + C \rightleftharpoons P$ के लिए वह $K_{eq}^{(2)}$ है, $A \rightleftharpoons P$

के लिए साम्य स्थिरांक है :

Options :

40503640869. $K_{eq}^{(1)} + K_{eq}^{(2)}$

40503640870. $K_{eq}^{(1)} / K_{eq}^{(2)}$

40503640871. $K_{eq}^{(1)} K_{eq}^{(2)}$

40503640872. $K_{eq}^{(2)} - K_{eq}^{(1)}$

Question Number : 29 Question Id : 40503611259 Question Type : MCQ Option Shuffling : Yes Display Question Number : Yes Is Question Mandatory : No Single Line Question Option : No Option Orientation : Vertical

Correct Marks : 4 Wrong Marks : 1

Five moles of an ideal gas at 1 bar and 298 K is expanded into vacuum to double the volume. The work done is :

Options :

40503640873. zero

40503640874. $-RT \ln V_2/V_1$

40503640875. $-RT (V_2 - V_1)$

40503640876. $C_V(T_2 - T_1)$

Question Number : 29 Question Id : 40503611259 Question Type : MCQ Option Shuffling : Yes Display Question Number : Yes Is Question Mandatory : No Single Line Question Option : No Option Orientation : Vertical

Correct Marks : 4 Wrong Marks : 1

एक आदर्श गैस के पाँच मोल को 1 bar तथा 298 K पर निर्वात में उसके आयतन के दुगुने तक प्रसारित किया गया। किया गया कार्य है :

Options :

40503640873. शून्य

40503640874. $-RT \ln V_2/V_1$

40503640875. $-RT (V_2 - V_1)$

40503640876. $C_V(T_2 - T_1)$

Question Number : 30 Question Id : 40503611260 Question Type : MCQ Option Shuffling : Yes
Display Question Number : Yes Is Question Mandatory : No Single Line Question Option : No Option
Orientation : Vertical

Correct Marks : 4 Wrong Marks : 1

The molecule in which hybrid MOs involve
only one d-orbital of the central atom is :

Options :

40503640877. $[\text{Ni}(\text{CN})_4]^{2-}$

40503640878. BrF_5

40503640879. $[\text{CrF}_6]^{3-}$

40503640880. XeF_4

Question Number : 30 Question Id : 40503611260 Question Type : MCQ Option Shuffling : Yes
Display Question Number : Yes Is Question Mandatory : No Single Line Question Option : No Option
Orientation : Vertical

Correct Marks : 4 Wrong Marks : 1

अणु, जिसके संकरित MO में केन्द्रीय परमाणु के
मात्र एक d-कक्षक सम्मिलित हैं, है :

Options :

40503640877. $[\text{Ni}(\text{CN})_4]^{2-}$

40503640878. BrF_5

40503640879. $[\text{CrF}_6]^{3-}$

40503640880. XeF_4

Question Number : 31 Question Id : 40503611261 Question Type : MCQ Option Shuffling : Yes
Display Question Number : Yes Is Question Mandatory : No Single Line Question Option : No Option
Orientation : Vertical

Correct Marks : 4 Wrong Marks : 1



The shortest wavelength of H atom in the Lyman series is λ_1 . The longest wavelength in the Balmer series of He^+ is :

Options :

40503640881. $\frac{36\lambda_1}{5}$

40503640882. $\frac{5\lambda_1}{9}$

40503640883. $\frac{9\lambda_1}{5}$

40503640884. $\frac{27\lambda_1}{5}$

Question Number : 31 Question Id : 40503611261 Question Type : MCQ Option Shuffling : Yes
Display Question Number : Yes Is Question Mandatory : No Single Line Question Option : No Option
Orientation : Vertical

Correct Marks : 4 Wrong Marks : 1

H परमाणु का सबसे छोटा तरंगदैर्घ्य लाइमैन श्रेणी में λ_1 है। He^+ का बामर श्रेणी में सबसे लम्बा तरंगदैर्घ्य है :

Options :

40503640881. $\frac{36\lambda_1}{5}$

40503640882. $\frac{5\lambda_1}{9}$

40503640883. $\frac{9\lambda_1}{5}$

40503640884. $\frac{27\lambda_1}{5}$



Question Number : 32 Question Id : 40503611262 Question Type : MCQ Option Shuffling : Yes

Display Question Number : Yes Is Question Mandatory : No Single Line Question Option : No Option
Orientation : Vertical

Correct Marks : 4 Wrong Marks : 1

The process that is NOT endothermic in nature is :

Options :

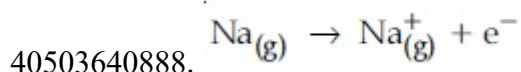
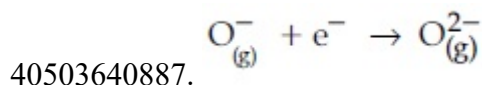
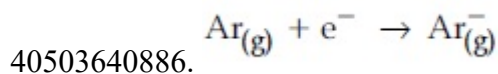
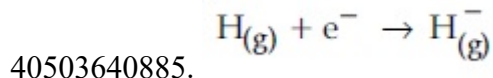

Question Number : 32 Question Id : 40503611262 Question Type : MCQ Option Shuffling : Yes
Display Question Number : Yes Is Question Mandatory : No Single Line Question Option : No Option
Orientation : Vertical

Correct Marks : 4 Wrong Marks : 1

प्रक्रम जो स्वभावतः ऊष्मा शोषी नहीं है :

Options :

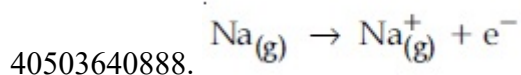
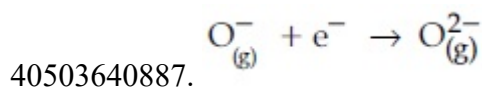
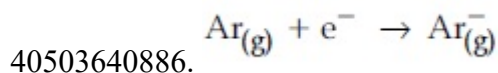
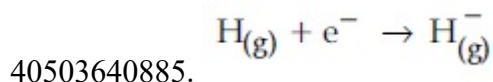

Question Number : 33 Question Id : 40503611263 Question Type : MCQ Option Shuffling : Yes
Display Question Number : Yes Is Question Mandatory : No Single Line Question Option : No Option
Orientation : Vertical

Correct Marks : 4 Wrong Marks : 1

An alkaline earth metal 'M' readily forms water soluble sulphate and water insoluble hydroxide. Its oxide MO is very stable to heat and does not have rock-salt structure. M is :

Options :

40503640889. Mg

40503640890. Be

40503640891. Ca

40503640892. Sr

Question Number : 33 Question Id : 40503611263 Question Type : MCQ Option Shuffling : Yes Display Question Number : Yes Is Question Mandatory : No Single Line Question Option : No Option Orientation : Vertical

Correct Marks : 4 Wrong Marks : 1

एक क्षारीय मृदा धातु 'M' शीघ्रतापूर्वक जल-विलेय सल्फेट तथा जल-अविलेय हाइड्राक्साइड बनाती है। इसकी आक्साइड MO ऊष्मा के प्रति अतिस्थायी है तथा खनिज नमक संरचना में नहीं होती है। M है :

Options :

40503640889. Mg

40503640890. Be

40503640891. Ca

40503640892. Sr

Question Number : 34 Question Id : 40503611264 Question Type : MCQ Option Shuffling : Yes Display Question Number : Yes Is Question Mandatory : No Single Line Question Option : No Option Orientation : Vertical

Correct Marks : 4 Wrong Marks : 1

The reaction in which the hybridisation of the underlined atom is affected is :

Options :

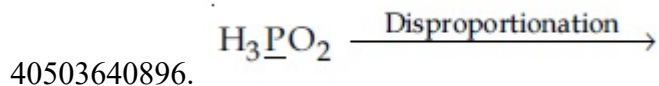
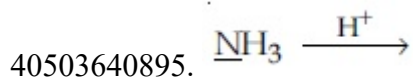
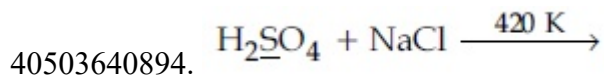
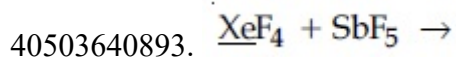

Question Number : 34 Question Id : 40503611264 Question Type : MCQ Option Shuffling : Yes Display Question Number : Yes Is Question Mandatory : No Single Line Question Option : No Option Orientation : Vertical

Correct Marks : 4 Wrong Marks : 1

अभिक्रिया जिसमें रेखांकित परमाणु का संकरण प्रभावित होता है, है :

Options :

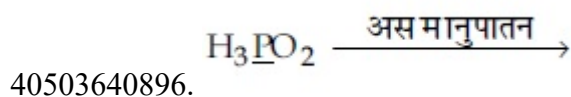
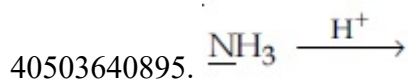
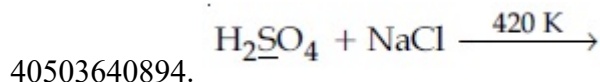

Question Number : 35 Question Id : 40503611265 Question Type : MCQ Option Shuffling : Yes Display Question Number : Yes Is Question Mandatory : No Single Line Question Option : No Option Orientation : Vertical

Correct Marks : 4 Wrong Marks : 1

The incorrect statement(s) among (a) - (c) is (are) :

- (a) W(VI) is more stable than Cr(VI).
- (b) in the presence of HCl, permanganate titrations provide satisfactory results.
- (c) some lanthanoid oxides can be used as phosphors.

Options :

40503640897. (a) only

40503640898. (b) only

40503640899. (a) and (b) only

40503640900. (b) and (c) only

Question Number : 35 Question Id : 40503611265 Question Type : MCQ Option Shuffling : Yes Display Question Number : Yes Is Question Mandatory : No Single Line Question Option : No Option Orientation : Vertical

Correct Marks : 4 Wrong Marks : 1

कथनों (a) - (c) में से गलत कथन है/हैं :

- (a) Cr(VI) की अपेक्षा W(VI) अधिक स्थायी है।
- (b) HCl की उपस्थिति में, परमैंगनेट अनुमापन संतोषप्रद परिणाम देते हैं।
- (c) कुछ लैन्थेनायड आक्साइडों को फॉस्फरों की तरह उपयोग में ला सकते हैं।

Options :

40503640897. (a) मात्र

40503640898. (b) मात्र

40503640899. (a) तथा (b) मात्र

40503640900. (b) तथा (c) मात्र

Question Number : 36 Question Id : 40503611266 Question Type : MCQ Option Shuffling : Yes
Display Question Number : Yes Is Question Mandatory : No Single Line Question Option : No Option
Orientation : Vertical

Correct Marks : 4 Wrong Marks : 1

The Crystal Field Stabilization Energy
(CFSE) of $[\text{CoF}_3(\text{H}_2\text{O})_3]$ ($\Delta_0 < P$) is :

Options :

40503640901. $-0.8 \Delta_0$

40503640902. $-0.4 \Delta_0$

40503640903. $-0.8 \Delta_0 + 2P$

40503640904. $-0.4 \Delta_0 + P$

Question Number : 36 Question Id : 40503611266 Question Type : MCQ Option Shuffling : Yes
Display Question Number : Yes Is Question Mandatory : No Single Line Question Option : No Option
Orientation : Vertical

Correct Marks : 4 Wrong Marks : 1

$[\text{CoF}_3(\text{H}_2\text{O})_3]$ की क्रिस्टल क्षेत्र स्थायीकरण ऊर्जा
(CFSE) ($\Delta_0 < P$) है :

Options :

40503640901. $-0.8 \Delta_0$

40503640902. $-0.4 \Delta_0$

40503640903. $-0.8 \Delta_0 + 2P$

40503640904. $-0.4 \Delta_0 + P$

Question Number : 37 Question Id : 40503611267 Question Type : MCQ Option Shuffling : Yes
Display Question Number : Yes Is Question Mandatory : No Single Line Question Option : No Option
Orientation : Vertical

Correct Marks : 4 Wrong Marks : 1

The one that can exhibit highest paramagnetic behaviour among the following is :

gly = glycinato; bpy = 2, 2'-bipyridine

Options :

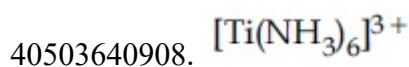
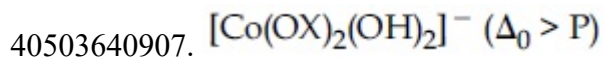
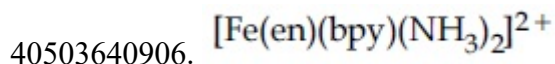
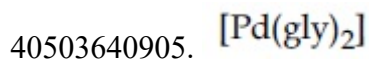

Question Number : 37 Question Id : 40503611267 Question Type : MCQ Option Shuffling : Yes
Display Question Number : Yes Is Question Mandatory : No Single Line Question Option : No Option
Orientation : Vertical

Correct Marks : 4 Wrong Marks : 1

निम्नलिखित में से वह जो सबसे अधिक अनुचुंबकीय व्यवहार प्रदर्शित करता है, है :

gly = ग्लाइसिनेटो; bpy = 2, 2'-बाईपिरिडीन

Options :

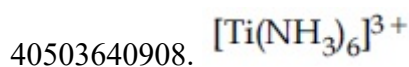
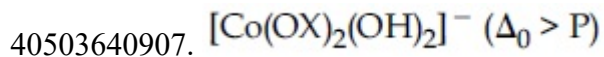
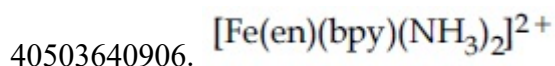
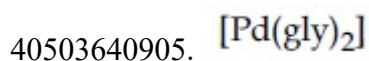

Question Number : 38 Question Id : 40503611268 Question Type : MCQ Option Shuffling : Yes
Display Question Number : Yes Is Question Mandatory : No Single Line Question Option : No Option
Orientation : Vertical

Correct Marks : 4 Wrong Marks : 1

The processes of calcination and roasting in metallurgical industries, respectively, can lead to :

Options :

40503640909. Global warming and acid rain
40503640910. Global warming and photochemical smog
40503640911. Photochemical smog and global warming
40503640912. Photochemical smog and ozone layer depletion

Question Number : 38 Question Id : 40503611268 Question Type : MCQ Option Shuffling : Yes Display Question Number : Yes Is Question Mandatory : No Single Line Question Option : No Option Orientation : Vertical

Correct Marks : 4 Wrong Marks : 1

धातुकर्मीय उद्योग में, निस्तापन तथा भर्जन के प्रक्रम क्रमशः पैदा करते हैं :

Options :

40503640909. वैश्विक तापन तथा अम्ल वर्षा
40503640910. वैश्विक तापन तथा प्रकाशरासायनिक धूमकुहा
40503640911. प्रकाशरासायनिक धूमकुहा तथा वैश्विक तापन
40503640912. प्रकाशरासायनिक धूमकुहा तथा ओजोन परत का अवक्षय

Question Number : 39 Question Id : 40503611269 Question Type : MCQ Option Shuffling : Yes Display Question Number : Yes Is Question Mandatory : No Single Line Question Option : No Option Orientation : Vertical

Correct Marks : 4 Wrong Marks : 1

Among the following compounds, which one has the shortest C–Cl bond ?

Options :

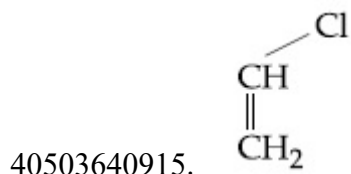
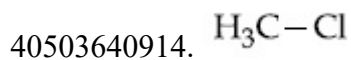
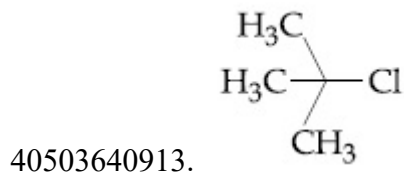

Question Number : 39 Question Id : 40503611269 Question Type : MCQ Option Shuffling : Yes Display Question Number : Yes Is Question Mandatory : No Single Line Question Option : No Option Orientation : Vertical

Correct Marks : 4 Wrong Marks : 1

निम्नलिखित यौगिकों में से किसमें C-Cl आबंध सबसे छोटा है?

Options :

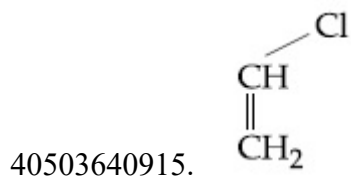
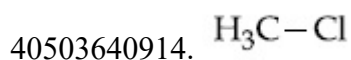
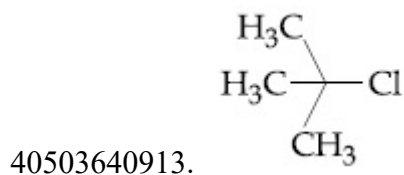

Question Number : 40 Question Id : 40503611270 Question Type : MCQ Option Shuffling : Yes
Display Question Number : Yes Is Question Mandatory : No Single Line Question Option : No Option
Orientation : Vertical

Correct Marks : 4 Wrong Marks : 1

Which of the following compounds will form the precipitate with aq. AgNO_3 solution most readily ?

Options :

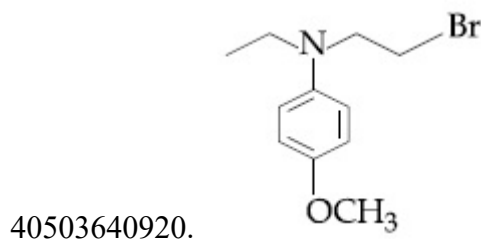
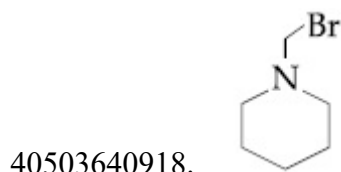
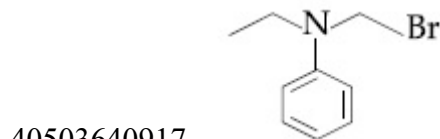

Question Number : 40 Question Id : 40503611270 Question Type : MCQ Option Shuffling : Yes
Display Question Number : Yes Is Question Mandatory : No Single Line Question Option : No Option
Orientation : Vertical

Correct Marks : 4 Wrong Marks : 1

निम्नलिखित यौगिकों में से कौन जलीय AgNO_3 विलयन के साथ सबसे शीघ्रतापूर्वक अवक्षेप देगा ?

Options :

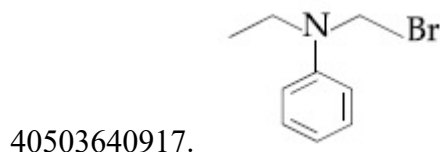

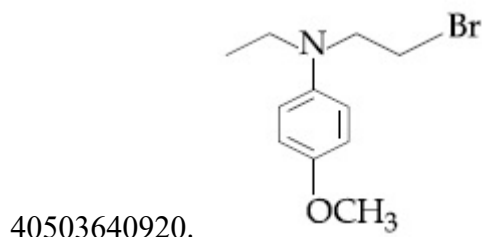
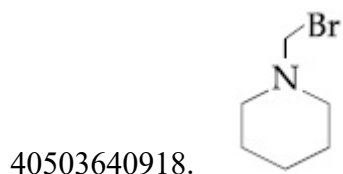

Question Number : 41 Question Id : 40503611271 Question Type : MCQ Option Shuffling : Yes Display Question Number : Yes Is Question Mandatory : No Single Line Question Option : No Option Orientation : Vertical

Correct Marks : 4 Wrong Marks : 1

The major product [B] in the following reactions is :

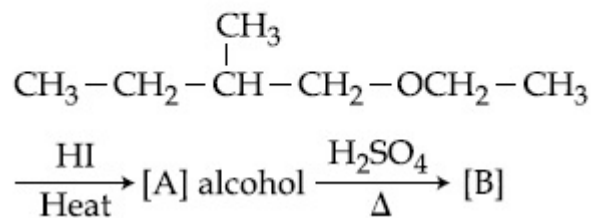

Options :

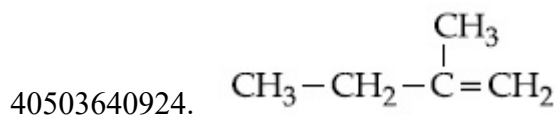
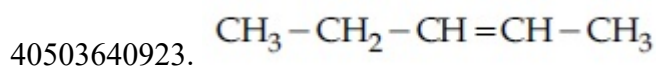
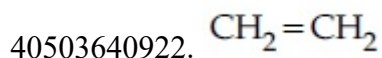
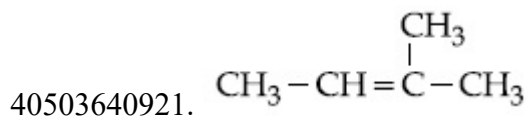

Question Number : 41 Question Id : 40503611271 Question Type : MCQ Option Shuffling : Yes Display Question Number : Yes Is Question Mandatory : No Single Line Question Option : No Option

Orientation : Vertical

Correct Marks : 4 Wrong Marks : 1

निम्नलिखित अभिक्रियाओं में मुख्य उत्पाद [B] है :

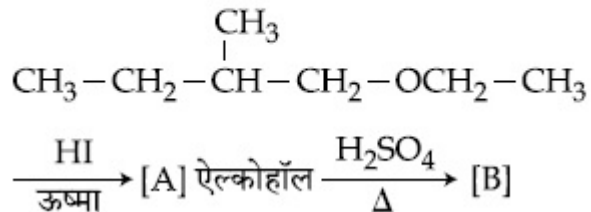

Options :

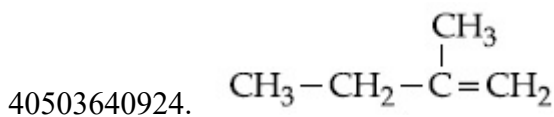
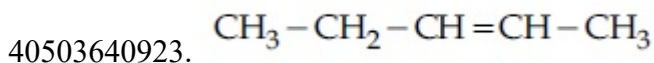
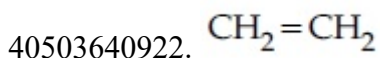
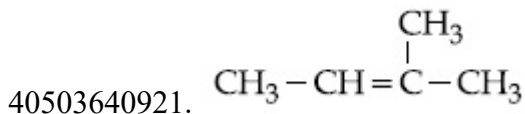

Question Number : 42 Question Id : 40503611272 Question Type : MCQ Option Shuffling : Yes
Display Question Number : Yes Is Question Mandatory : No Single Line Question Option : No Option
Orientation : Vertical

Correct Marks : 4 Wrong Marks : 1

In the following reaction sequence, [C] is :

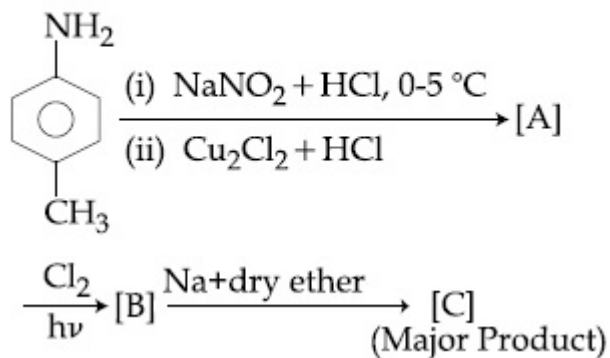

Options :

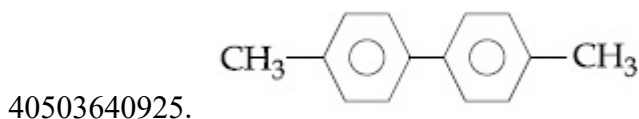

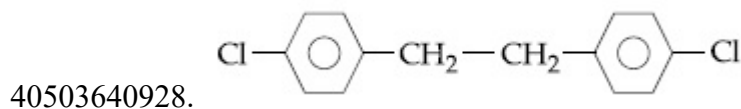
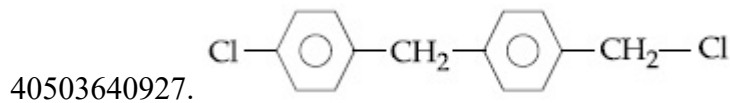
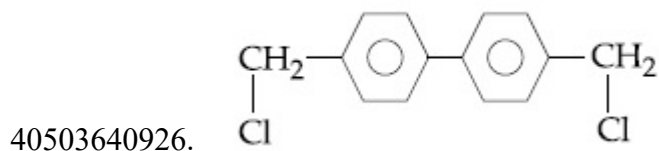

Question Number : 42 Question Id : 40503611272 Question Type : MCQ Option Shuffling : Yes Display Question Number : Yes Is Question Mandatory : No Single Line Question Option : No Option Orientation : Vertical

Correct Marks : 4 Wrong Marks : 1

निम्नलिखित अभिक्रिया अनुक्रम में, [C] है :

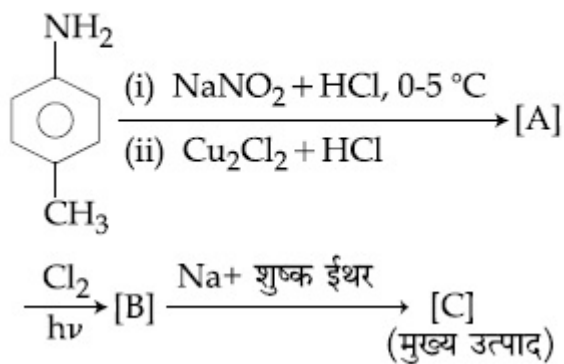

Options :

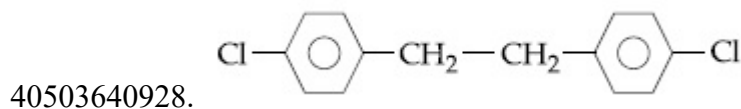
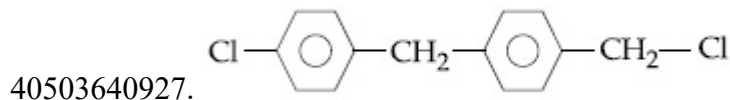
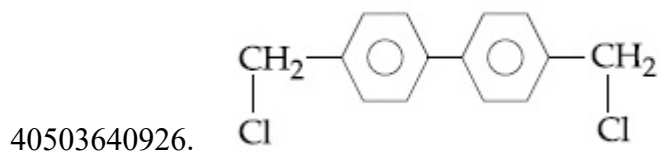
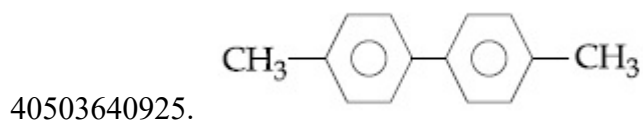

Question Number : 43 Question Id : 40503611273 Question Type : MCQ Option Shuffling : Yes
Display Question Number : Yes Is Question Mandatory : No Single Line Question Option : No Option
Orientation : Vertical
Correct Marks : 4 Wrong Marks : 1

The mechanism of action of "Terfenadine"
(Seldane) is :

Options :

40503640929. Inhibits the secretion of histamine
40503640930. Helps in the secretion of histamine
40503640931. Activates the histamine receptor
40503640932. Inhibits the action of histamine
receptor

Question Number : 43 Question Id : 40503611273 Question Type : MCQ Option Shuffling : Yes
Display Question Number : Yes Is Question Mandatory : No Single Line Question Option : No Option
Orientation : Vertical
Correct Marks : 4 Wrong Marks : 1

"टरफेनाडीन" (सेल्डेन) के कार्य करने की क्रियाविधि
है :

Options :

40503640929. हिस्टैमिन के स्राव को निरोधित करता है।
40503640930. हिस्टैमिन के स्राव में सहायता करता है।
40503640931. हिस्टैमिन-अभिग्राही को सक्रिय करता है।
40503640932. हिस्टैमिन-अभिग्राही की क्रिया को निरोधित
करता है।

Question Number : 44 Question Id : 40503611274 Question Type : MCQ Option Shuffling : Yes
Display Question Number : Yes Is Question Mandatory : No Single Line Question Option : No Option
Orientation : Vertical
Correct Marks : 4 Wrong Marks : 1



The major product [R] in the following sequence of reactions is :

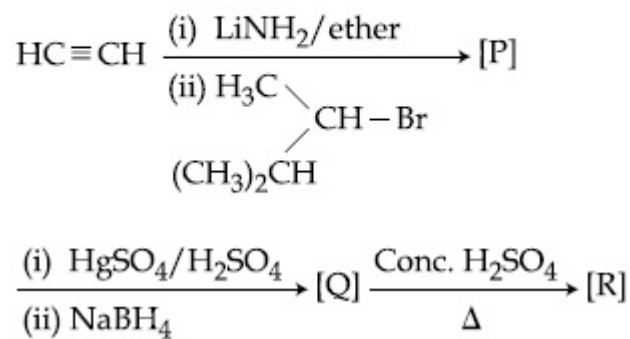

Options :

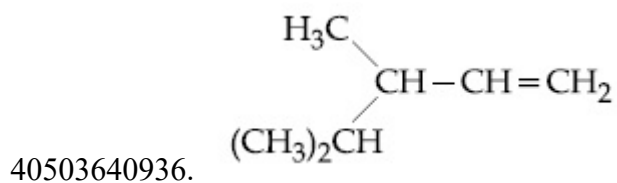
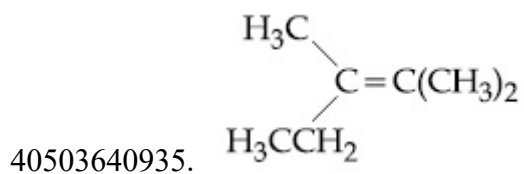
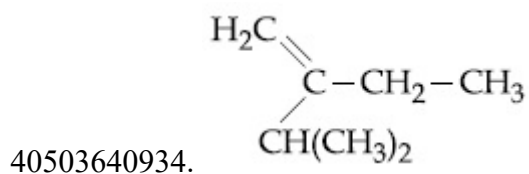
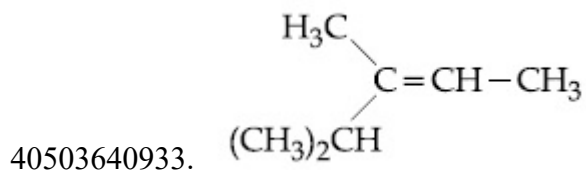

Question Number : 44 Question Id : 40503611274 Question Type : MCQ Option Shuffling : Yes
 Display Question Number : Yes Is Question Mandatory : No Single Line Question Option : No Option
 Orientation : Vertical
 Correct Marks : 4 Wrong Marks : 1

निम्नलिखित अभिक्रिया-अनुक्रम में मुख्य उत्पाद [R]

है :

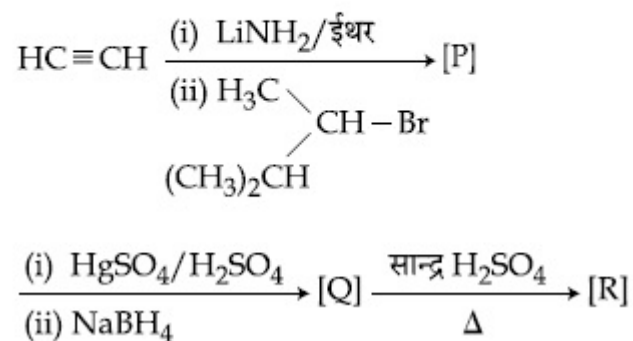

Options :

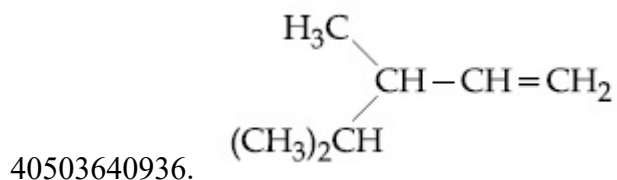
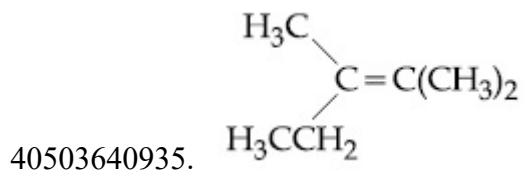
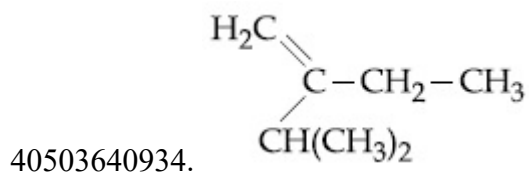
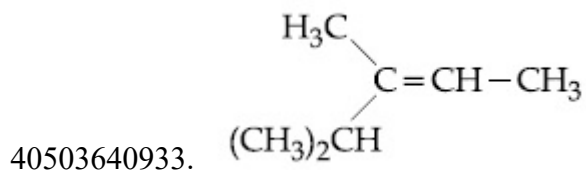

Question Number : 45 Question Id : 40503611275 Question Type : MCQ Option Shuffling : Yes
Display Question Number : Yes Is Question Mandatory : No Single Line Question Option : No Option
Orientation : Vertical
Correct Marks : 4 Wrong Marks : 1

The major product [C] of the following reaction sequence will be :

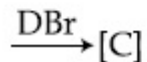
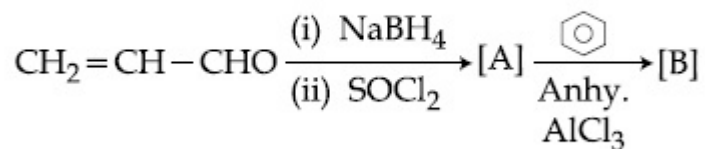

Options :

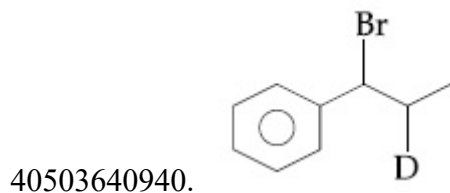
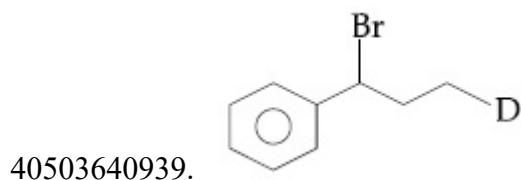
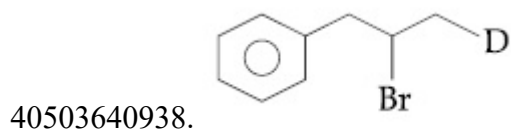
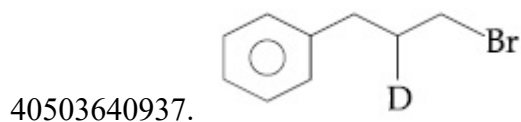

Question Number : 45 Question Id : 40503611275 Question Type : MCQ Option Shuffling : Yes
 Display Question Number : Yes Is Question Mandatory : No Single Line Question Option : No Option
 Orientation : Vertical

Correct Marks : 4 Wrong Marks : 1

निम्नलिखित अभिक्रिया-अनुक्रम में मुख्य उत्पाद [C]
 है :

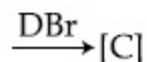
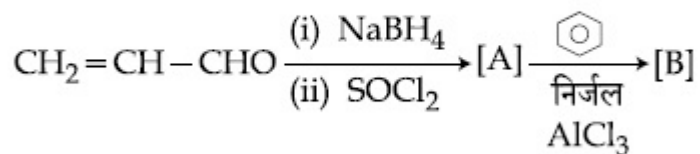

Options :

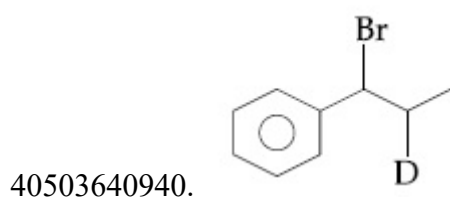
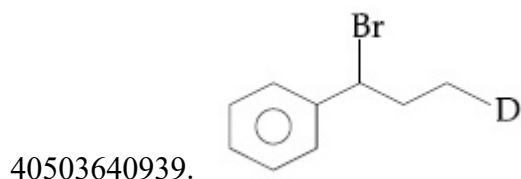
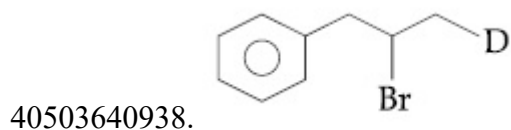
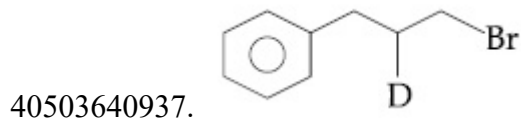

Sub-Section Number :

2

Sub-Section Id :

405036788

Question Shuffling Allowed :

Yes

**Question Number : 46 Question Id : 40503611276 Question Type : SA Display Question Number : Yes
Correct Marks : 4 Wrong Marks : 0**

A 100 mL solution was made by adding 1.43 g of $\text{Na}_2\text{CO}_3 \cdot x\text{H}_2\text{O}$. The normality of the solution is 0.1 N. The value of x is _____.

(The atomic mass of Na is 23 g/mol)

Response Type : Numeric

Evaluation Required For SA : Yes

Show Word Count : Yes

Answers Type : Range

Text Areas : PlainText

Possible Answers :

5 to 5.002

**Question Number : 46 Question Id : 40503611276 Question Type : SA Display Q
Correct Marks : 4 Wrong Marks : 0**

$\text{Na}_2\text{CO}_3 \cdot x\text{H}_2\text{O}$ के 1.43 g को मिलाकर 100 mL का एक विलयन बनाया गया। विलयन की नार्मलिटी 0.1 N है। x का मान है _____।
(Na की परमाणु संहति 23 g/mol है)

Response Type : Numeric

Evaluation Required For SA : Yes

Show Word Count : Yes

Answers Type : Range

Text Areas : PlainText

Possible Answers :

5 to 5.002

Question Number : 47 **Question Id :** 40503611277 **Question Type :** SA Display **Question Number :** Yes

Correct Marks : 4 **Wrong Marks :** 0

The osmotic pressure of a solution of NaCl is 0.10 atm and that of a glucose solution is 0.20 atm. The osmotic pressure of a solution formed by mixing 1 L of the sodium chloride solution with 2 L of the glucose solution is $x \times 10^{-3}$ atm. x is _____. (nearest integer)

Response Type : Numeric

Evaluation Required For SA : Yes

Show Word Count : Yes

Answers Type : Range

Text Areas : PlainText

Possible Answers :

5 to 5.002

Question Number : 47 **Question Id :** 40503611277 **Question Type :** SA Display **Question Number :** Yes

Correct Marks : 4 **Wrong Marks :** 0

NaCl के एक विलयन का परासरण दाब 0.10 atm है तथा ग्लूकोस के एक विलयन का परासरण दाब 0.20 atm है। सोडियम क्लोराइड के विलयन के 1 L को ग्लूकोस के विलयन के 2 L में मिलाकर बनाये गये विलयन का परासरण दाब है $x \times 10^{-3}$ atm. x है _____ (निकटतम पूर्णांक)।

Response Type : Numeric

Evaluation Required For SA : Yes

Show Word Count : Yes

Answers Type : Range

Text Areas : PlainText

Possible Answers :

5 to 5.002

Question Number : 48 Question Id : 40503611278 Question Type : SA Display Question Number : Yes

Correct Marks : 4 Wrong Marks : 0

The number of molecules with energy greater than the threshold energy for a reaction increases five fold by a rise of temperature from 27 °C to 42 °C. Its energy of activation in J/mol is _____. (Take $\ln 5 = 1.6094$; $R = 8.314 \text{ J mol}^{-1}\text{K}^{-1}$)

Response Type : Numeric

Evaluation Required For SA : Yes

Show Word Count : Yes

Answers Type : Range

Text Areas : PlainText

Possible Answers :

5 to 5.002

Question Number : 48 Question Id : 40503611278 Question Type : SA Display Question Number : Yes

Correct Marks : 4 Wrong Marks : 0

एक अभिक्रिया में, अणुओं, जिनकी ऊर्जा, देहली ऊर्जा की अपेक्षा अधिक है, उसकी संख्या ताप के 27 °C से 42 °C तक बढ़ने से पाँच गुना बढ़ जाती है। इसकी सक्रियण ऊर्जा (J/mol में) है _____। (मानें, $\ln 5 = 1.6094$; $R = 8.314 \text{ J mol}^{-1}\text{K}^{-1}$)

Response Type : Numeric

Evaluation Required For SA : Yes

Show Word Count : Yes

Answers Type : Range

Text Areas : PlainText

Possible Answers :

5 to 5.002



Question Number : 49 Question Id : 40503611279 Question Type : SA Display Question Number : Yes

Correct Marks : 4 Wrong Marks : 0

Consider the following equations :

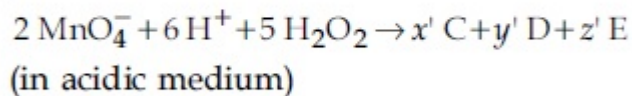
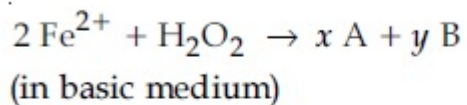

The sum of the stoichiometric coefficients x , y , x' , y' and z' for products A, B, C, D and E, respectively, is _____.

Response Type : Numeric

Evaluation Required For SA : Yes

Show Word Count : Yes

Answers Type : Range

Text Areas : PlainText

Possible Answers :

5 to 5.002

Question Number : 49 **Question Id :** 40503611279 **Question Type :** SA Display **Question Number :** Yes

Correct Marks : 4 **Wrong Marks :** 0

निम्नलिखित समीकरणों पर विचार कीजिए :

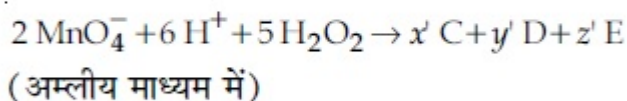
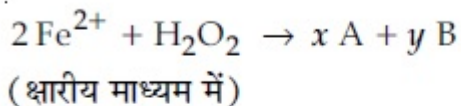

A, B, C, D तथा E उत्पादों के लिए क्रमशः स्टाइकियोमित्री गुणांकों x , y , x' , y' तथा z' का योग है _____।

Response Type : Numeric

Evaluation Required For SA : Yes

Show Word Count : Yes

Answers Type : Range

Text Areas : PlainText

Possible Answers :

5 to 5.002

Question Number : 50 **Question Id :** 40503611280 **Question Type :** SA Display **Question Number :** Yes

Correct Marks : 4 **Wrong Marks :** 0

The number of chiral centres present in threonine is _____.

Response Type : Numeric

Evaluation Required For SA : Yes

Show Word Count : Yes

Answers Type : Range

Text Areas : PlainText

Possible Answers :

5 to 5.002

Question Number : 50 Question Id : 40503611280 Question Type : SA Display Question Number : Yes

Correct Marks : 4 Wrong Marks : 0

थ्रिआनीन में उपस्थित काइरल केन्द्रों की संख्या है _____।

Response Type : Numeric

Evaluation Required For SA : Yes

Show Word Count : Yes

Answers Type : Range

Text Areas : PlainText

Possible Answers :

5 to 5.002

Mathematics

Section Id :	405036411
Section Number :	3
Section type :	Online
Mandatory or Optional :	Mandatory
Number of Questions :	25
Number of Questions to be attempted :	25
Section Marks :	100
Display Number Panel :	Yes
Group All Questions :	Yes
Mark As Answered Required? :	Yes
Sub-Section Number :	1
Sub-Section Id :	405036789
Question Shuffling Allowed :	Yes

Question Number : 51 Question Id : 40503611281 Question Type : MCQ Option Shuffling : Yes
Display Question Number : Yes Is Question Mandatory : No Single Line Question Option : No Option
Orientation : Vertical
Correct Marks : 4 Wrong Marks : 1

Let $\bigcup_{i=1}^{50} X_i = \bigcup_{i=1}^n Y_i = T$, where each X_i

contains 10 elements and each Y_i contains 5 elements. If each element of the set T is an element of exactly 20 of sets X_i 's and exactly 6 of sets Y_i 's, then n is equal to :

Options :

40503640946. 15

40503640947. 30

40503640948. 45

40503640949. 50

Question Number : 51 Question Id : 40503611281 Question Type : MCQ Option Shuffling : Yes Display Question Number : Yes Is Question Mandatory : No Single Line Question Option : No Option Orientation : Vertical

Correct Marks : 4 Wrong Marks : 1

माना $\bigcup_{i=1}^{50} X_i = \bigcup_{i=1}^n Y_i = T$ है, जहाँ प्रत्येक X_i में

10 अवयव हैं तथा प्रत्येक Y_i में 5 अवयव हैं। यदि T का प्रत्येक अवयव ठीक 20, X_i समुच्चयों का एक अवयव है तथा ठीक 6, Y_i समुच्चयों का एक अवयव है, तो n का मान है :

Options :

40503640946. 15

40503640947. 30

40503640948. 45

40503640949. 50

Question Number : 52 Question Id : 40503611282 Question Type : MCQ Option Shuffling : Yes Display Question Number : Yes Is Question Mandatory : No Single Line Question Option : No Option Orientation : Vertical

Correct Marks : 4 Wrong Marks : 1

Let $\lambda \neq 0$ be in \mathbb{R} . If α and β are the roots of the equation, $x^2 - x + 2\lambda = 0$ and α and γ are the roots of the equation, $3x^2 - 10x + 27\lambda = 0$, then $\frac{\beta\gamma}{\lambda}$ is equal to :

Options :

40503640950. 36

40503640951. 27

40503640952. 18

40503640953. 9

Question Number : 52 Question Id : 40503611282 Question Type : MCQ Option Shuffling : Yes Display Question Number : Yes Is Question Mandatory : No Single Line Question Option : No Option Orientation : Vertical

Correct Marks : 4 Wrong Marks : 1

माना $\lambda \neq 0$, \mathbb{R} में है। यदि α तथा β समीकरण $x^2 - x + 2\lambda = 0$ के मूल हैं और α तथा γ , समीकरण $3x^2 - 10x + 27\lambda = 0$ के मूल हैं, तो $\frac{\beta\gamma}{\lambda}$ बराबर है :

Options :

40503640950. 36

40503640951. 27

40503640952. 18

40503640953. 9

Question Number : 53 Question Id : 40503611283 Question Type : MCQ Option Shuffling : Yes Display Question Number : Yes Is Question Mandatory : No Single Line Question Option : No Option Orientation : Vertical

Correct Marks : 4 Wrong Marks : 1

If a and b are real numbers such that

$$(2 + \alpha)^4 = a + b\alpha, \text{ where } \alpha = \frac{-1 + i\sqrt{3}}{2},$$

then a + b is equal to :

Options :

40503640954. 9

40503640955. 24

40503640956. 33

40503640957. 57

**Question Number : 53 Question Id : 40503611283 Question Type : MCQ Option Shuffling : Yes
Display Question Number : Yes Is Question Mandatory : No Single Line Question Option : No Option
Orientation : Vertical**

Correct Marks : 4 Wrong Marks : 1

यदि a तथा b ऐसी वास्तविक संख्याएँ है कि

$$(2 + \alpha)^4 = a + b\alpha \text{ है, जहाँ } \alpha = \frac{-1 + i\sqrt{3}}{2} \text{ है, तो}$$

a + b का मान है :

Options :

40503640954. 9

40503640955. 24

40503640956. 33

40503640957. 57

**Question Number : 54 Question Id : 40503611284 Question Type : MCQ Option Shuffling : Yes
Display Question Number : Yes Is Question Mandatory : No Single Line Question Option : No Option
Orientation : Vertical**

Correct Marks : 4 Wrong Marks : 1

If the system of equations

$$x + y + z = 2$$

$$2x + 4y - z = 6$$

$$3x + 2y + \lambda z = \mu$$

has infinitely many solutions, then :

Options :

40503640958. $\lambda - 2\mu = -5$

40503640959. $\lambda + 2\mu = 14$

40503640960. $2\lambda - \mu = 5$

40503640961. $2\lambda + \mu = 14$

**Question Number : 54 Question Id : 40503611284 Question Type : MCQ Option Shuffling : Yes
Display Question Number : Yes Is Question Mandatory : No Single Line Question Option : No Option
Orientation : Vertical**

Correct Marks : 4 Wrong Marks : 1

यदि समीकरणों के निकाय

$$x + y + z = 2$$

$$2x + 4y - z = 6$$

$$3x + 2y + \lambda z = \mu$$

के अनन्त हल हैं, तो :

Options :

40503640958. $\lambda - 2\mu = -5$

40503640959. $\lambda + 2\mu = 14$

40503640960. $2\lambda - \mu = 5$

40503640961. $2\lambda + \mu = 14$



**Question Number : 55 Question Id : 40503611285 Question Type : MCQ Option Shuffling : Yes
Display Question Number : Yes Is Question Mandatory : No Single Line Question Option : No Option
Orientation : Vertical**

Correct Marks : 4 Wrong Marks : 1

Suppose the vectors x_1 , x_2 and x_3 are the solutions of the system of linear equations, $Ax = b$ when the vector b on the right side is equal to b_1 , b_2 and b_3 respectively. If

$$x_1 = \begin{bmatrix} 1 \\ 1 \\ 1 \end{bmatrix}, x_2 = \begin{bmatrix} 0 \\ 2 \\ 1 \end{bmatrix}, x_3 = \begin{bmatrix} 0 \\ 0 \\ 1 \end{bmatrix}, b_1 = \begin{bmatrix} 1 \\ 0 \\ 0 \end{bmatrix},$$

$$b_2 = \begin{bmatrix} 0 \\ 2 \\ 0 \end{bmatrix} \text{ and } b_3 = \begin{bmatrix} 0 \\ 0 \\ 2 \end{bmatrix}, \text{ then the}$$

determinant of A is equal to :

Options :

40503640962. $\frac{1}{2}$

40503640963. 2

40503640964. $\frac{3}{2}$

40503640965. 4

Question Number : 55 Question Id : 40503611285 Question Type : MCQ Option Shuffling : Yes Display Question Number : Yes Is Question Mandatory : No Single Line Question Option : No Option Orientation : Vertical Correct Marks : 4 Wrong Marks : 1

माना सदिश x_1, x_2 तथा x_3 , रेखिक समीकरण निकाय $Ax = b$ के हल हैं, जबकि दाईं ओर का सदिश b , क्रमशः b_1, b_2 तथा b_3 के बराबर है। यदि

$$x_1 = \begin{bmatrix} 1 \\ 1 \\ 1 \end{bmatrix}, x_2 = \begin{bmatrix} 0 \\ 2 \\ 1 \end{bmatrix}, x_3 = \begin{bmatrix} 0 \\ 0 \\ 1 \end{bmatrix}, b_1 = \begin{bmatrix} 1 \\ 0 \\ 0 \end{bmatrix},$$

$$b_2 = \begin{bmatrix} 0 \\ 2 \\ 0 \end{bmatrix} \text{ तथा } b_3 = \begin{bmatrix} 0 \\ 0 \\ 2 \end{bmatrix} \text{ हैं, तो } A \text{ के सारणिक}$$

का मान है :

Options :

40503640962. $\frac{1}{2}$

40503640963. 2

40503640964. $\frac{3}{2}$

40503640965. 4

Question Number : 56 Question Id : 40503611286 Question Type : MCQ Option Shuffling : Yes Display Question Number : Yes Is Question Mandatory : No Single Line Question Option : No Option Orientation : Vertical

Correct Marks : 4 Wrong Marks : 1

If for some positive integer n , the coefficients of three consecutive terms in the binomial expansion of $(1 + x)^{n+5}$ are in the ratio $5 : 10 : 14$, then the largest coefficient in this expansion is :

Options :

40503640966. 252

40503640967. 330

40503640968. 462

40503640969. 792

Question Number : 56 Question Id : 40503611286 Question Type : MCQ Option Shuffling : Yes Display Question Number : Yes Is Question Mandatory : No Single Line Question Option : No Option Orientation : Vertical

Correct Marks : 4 Wrong Marks : 1

माना किसी धनपूर्णांक n के लिए, $(1+x)^{n+5}$ के द्विपद प्रसार में तीन क्रमागत पदों के गुणांक 5 : 10 : 14 के अनुपात में हैं, तो इस प्रसार में सब से बड़ा गुणांक है :

Options :

40503640966. 252

40503640967. 330

40503640968. 462

40503640969. 792

Question Number : 57 Question Id : 40503611287 Question Type : MCQ Option Shuffling : Yes Display Question Number : Yes Is Question Mandatory : No Single Line Question Option : No Option Orientation : Vertical

Correct Marks : 4 Wrong Marks : 1

Let a_1, a_2, \dots, a_n be a given A.P. whose common difference is an integer and $S_n = a_1 + a_2 + \dots + a_n$. If $a_1 = 1, a_n = 300$ and $15 \leq n \leq 50$, then the ordered pair (S_{n-4}, a_{n-4}) is equal to :

Options :

40503640970. (2490, 248)

40503640971. (2480, 249)

40503640972. (2490, 249)

40503640973. (2480, 248)

Question Number : 57 Question Id : 40503611287 Question Type : MCQ Option Shuffling : Yes
Display Question Number : Yes Is Question Mandatory : No Single Line Question Option : No Option
Orientation : Vertical

Correct Marks : 4 Wrong Marks : 1

माना a_1, a_2, \dots, a_n एक दी गई समांतर श्रेणी है,
जिसका सार्वअंतर एक पूर्णांक है तथा
 $S_n = a_1 + a_2 + \dots + a_n$ है। यदि $a_1 = 1, a_n = 300$
तथा $15 \leq n \leq 50$ हैं, तो क्रमित युग्म
(S_{n-4}, a_{n-4}) बराबर है :

Options :

40503640970. (2490, 248)

40503640971. (2480, 249)

40503640972. (2490, 249)

40503640973. (2480, 248)

Question Number : 58 Question Id : 40503611288 Question Type : MCQ Option Shuffling : Yes
Display Question Number : Yes Is Question Mandatory : No Single Line Question Option : No Option
Orientation : Vertical

Correct Marks : 4 Wrong Marks : 1

Let $f : (0, \infty) \rightarrow (0, \infty)$ be a differentiable
function such that $f(1) = e$ and

$$\lim_{t \rightarrow x} \frac{t^2 f^2(x) - x^2 f^2(t)}{t - x} = 0.$$

If $f(x) = 1$, then x is equal to :

Options :

40503640974. e

40503640975. $\frac{1}{e}$

40503640976. $2e$

40503640977. $\frac{1}{2e}$

Question Number : 58 Question Id : 40503611288 Question Type : MCQ Option Shuffling : Yes Display Question Number : Yes Is Question Mandatory : No Single Line Question Option : No Option Orientation : Vertical

Correct Marks : 4 Wrong Marks : 1

माना $f : (0, \infty) \rightarrow (0, \infty)$ एक ऐसा अवकलनीय फलन है कि $f(1) = e$ तथा

$$\lim_{t \rightarrow x} \frac{t^2 f^2(x) - x^2 f^2(t)}{t - x} = 0 \text{ हैं। यदि } f(x) = 1$$

है, तो x का मान है :

Options :

40503640974. e

40503640975. $\frac{1}{e}$

40503640976. $2e$

40503640977. $\frac{1}{2e}$

Question Number : 59 Question Id : 40503611289 Question Type : MCQ Option Shuffling : Yes Display Question Number : Yes Is Question Mandatory : No Single Line Question Option : No Option Orientation : Vertical

Correct Marks : 4 Wrong Marks : 1

$$\text{The function } f(x) = \begin{cases} \frac{\pi}{4} + \tan^{-1}x, & |x| \leq 1 \\ \frac{1}{2}(|x| - 1), & |x| > 1 \end{cases}$$

is :

Options :

40503640978. both continuous and differentiable on $\mathbb{R} - \{1\}$.

40503640979. continuous on $\mathbb{R} - \{-1\}$ and differentiable on $\mathbb{R} - \{-1, 1\}$.

40503640980. continuous on $\mathbb{R} - \{1\}$ and differentiable on $\mathbb{R} - \{-1, 1\}$.

40503640981. both continuous and differentiable on $\mathbb{R} - \{-1\}$.

Question Number : 59 Question Id : 40503611289 Question Type : MCQ Option Shuffling : Yes Display Question Number : Yes Is Question Mandatory : No Single Line Question Option : No Option Orientation : Vertical Correct Marks : 4 Wrong Marks : 1

$$\text{फलन } f(x) = \begin{cases} \frac{\pi}{4} + \tan^{-1}x, & |x| \leq 1 \\ \frac{1}{2} (|x| - 1), & |x| > 1 \end{cases} :$$

Options :

40503640978. $\mathbb{R} - \{1\}$ में संतत और अवकलनीय, दोनों, है।

40503640979. $\mathbb{R} - \{-1\}$ में संतत तथा $\mathbb{R} - \{-1, 1\}$ में अवकलनीय है।

40503640980. $\mathbb{R} - \{1\}$ में संतत तथा $\mathbb{R} - \{-1, 1\}$ में अवकलनीय है।

40503640981. $\mathbb{R} - \{-1\}$ में संतत और अवकलनीय, दोनों, है।

Question Number : 60 Question Id : 40503611290 Question Type : MCQ Option Shuffling : Yes Display Question Number : Yes Is Question Mandatory : No Single Line Question Option : No Option Orientation : Vertical Correct Marks : 4 Wrong Marks : 1

The minimum value of $2^{\sin x} + 2^{\cos x}$ is :

Options :

40503640982. $2^{1 - \frac{1}{\sqrt{2}}}$

40503640983. $2^{-1+\sqrt{2}}$

40503640984. $2^{-1+\frac{1}{\sqrt{2}}}$

40503640985. $2^{1-\sqrt{2}}$

Question Number : 60 Question Id : 40503611290 Question Type : MCQ Option Shuffling : Yes Display Question Number : Yes Is Question Mandatory : No Single Line Question Option : No Option Orientation : Vertical

Correct Marks : 4 Wrong Marks : 1

$2^{\sin x} + 2^{\cos x}$ का न्यूनतम मान है :

Options :

40503640982. $2^{1-\frac{1}{\sqrt{2}}}$

40503640983. $2^{-1+\sqrt{2}}$

40503640984. $2^{-1+\frac{1}{\sqrt{2}}}$

40503640985. $2^{1-\sqrt{2}}$

Question Number : 61 Question Id : 40503611291 Question Type : MCQ Option Shuffling : Yes Display Question Number : Yes Is Question Mandatory : No Single Line Question Option : No Option Orientation : Vertical

Correct Marks : 4 Wrong Marks : 1

The integral

$$\int_{\pi/6}^{\pi/3} \tan^3 x \cdot \sin^2 3x (2 \sec^2 x \cdot \sin^2 3x + 3 \tan x \cdot \sin 6x) dx \text{ is}$$

equal to :

Options :

40503640986. $\frac{7}{18}$

40503640987. $-\frac{1}{9}$

40503640988. $\frac{9}{2}$

40503640989. $-\frac{1}{18}$

Question Number : 61 Question Id : 40503611291 Question Type : MCQ Option Shuffling : Yes Display Question Number : Yes Is Question Mandatory : No Single Line Question Option : No Option Orientation : Vertical Correct Marks : 4 Wrong Marks : 1

समाकल

$$\int_{\pi/6}^{\pi/3} \tan^3 x \cdot \sin^2 3x (2 \sec^2 x \cdot \sin^2 3x + 3 \tan x \cdot \sin 6x) dx$$

का मान है :

Options :

40503640986. $\frac{7}{18}$

40503640987. $-\frac{1}{9}$

40503640988. $\frac{9}{2}$

40503640989. $-\frac{1}{18}$

Question Number : 62 Question Id : 40503611292 Question Type : MCQ Option Shuffling : Yes Display Question Number : Yes Is Question Mandatory : No Single Line Question Option : No Option Orientation : Vertical Correct Marks : 4 Wrong Marks : 1

The area (in sq. units) of the largest rectangle ABCD whose vertices A and B lie on the x -axis and vertices C and D lie on the parabola, $y = x^2 - 1$ below the x -axis, is :

Options :

40503640990. $\frac{2}{3\sqrt{3}}$

40503640991. $\frac{1}{3\sqrt{3}}$

40503640992. $\frac{4}{3\sqrt{3}}$

40503640993. $\frac{4}{3}$

Question Number : 62 Question Id : 40503611292 Question Type : MCQ Option Shuffling : Yes
Display Question Number : Yes Is Question Mandatory : No Single Line Question Option : No Option
Orientation : Vertical

Correct Marks : 4 Wrong Marks : 1

उस सबसे बड़ी आयत ABCD, जिसके शीर्ष बिंदु A तथा B, x -अक्ष पर स्थित हैं तथा शीर्ष बिंदु C तथा D, x -अक्ष के नीचे, परवलय $y = x^2 - 1$ पर स्थित हैं, का क्षेत्रफल (वर्ग इकाइयों में) है :

Options :

40503640990. $\frac{2}{3\sqrt{3}}$

40503640991. $\frac{1}{3\sqrt{3}}$

40503640992. $\frac{4}{3\sqrt{3}}$

40503640993.

$\frac{4}{3}$

Question Number : 63 Question Id : 40503611293 Question Type : MCQ Option Shuffling : Yes
Display Question Number : Yes Is Question Mandatory : No Single Line Question Option : No Option
Orientation : Vertical

Correct Marks : 4 Wrong Marks : 1

The solution of the differential equation

$$\frac{dy}{dx} - \frac{y + 3x}{\log_e(y + 3x)} + 3 = 0 \text{ is :}$$

(where C is a constant of integration.)

Options :

40503640994. $x - \log_e(y + 3x) = C$

40503640995. $x - 2\log_e(y + 3x) = C$

40503640996. $x - \frac{1}{2}(\log_e(y + 3x))^2 = C$

40503640997. $y + 3x - \frac{1}{2}(\log_e x)^2 = C$

Question Number : 63 Question Id : 40503611293 Question Type : MCQ Option Shuffling : Yes
Display Question Number : Yes Is Question Mandatory : No Single Line Question Option : No Option
Orientation : Vertical

Correct Marks : 4 Wrong Marks : 1

अवकल समीकरण

$$\frac{dy}{dx} - \frac{y + 3x}{\log_e(y + 3x)} + 3 = 0 \text{ का हल है :}$$

(जहाँ C एक समाकलन अचर है।)

Options :

40503640994. $x - \log_e(y + 3x) = C$

40503640995. $x - 2\log_e(y + 3x) = C$

40503640996. $x - \frac{1}{2}(\log_e(y + 3x))^2 = C$

40503640997. $y + 3x - \frac{1}{2}(\log_e x)^2 = C$

Question Number : 64 Question Id : 40503611294 Question Type : MCQ Option Shuffling : Yes Display Question Number : Yes Is Question Mandatory : No Single Line Question Option : No Option Orientation : Vertical

Correct Marks : 4 Wrong Marks : 1

If the perpendicular bisector of the line segment joining the points P(1, 4) and Q(k, 3) has y-intercept equal to -4, then a value of k is :

Options :

40503640998. $\sqrt{14}$

40503640999. -2

40503641000. $\sqrt{15}$

40503641001. -4

Question Number : 64 Question Id : 40503611294 Question Type : MCQ Option Shuffling : Yes Display Question Number : Yes Is Question Mandatory : No Single Line Question Option : No Option Orientation : Vertical

Correct Marks : 4 Wrong Marks : 1

यदि बिंदुओं P(1, 4) तथा Q(k, 3) को मिलाने वाले रेखाखण्ड के लंबसमद्विभाजक का y-अंतःखण्ड -4 है, तो k का एक मान है :

Options :

40503640998. $\sqrt{14}$

40503640999. -2

40503641000. $\sqrt{15}$

40503641001. -4

Question Number : 65 Question Id : 40503611295 Question Type : MCQ Option Shuffling : Yes Display Question Number : Yes Is Question Mandatory : No Single Line Question Option : No Option Orientation : Vertical

Correct Marks : 4 Wrong Marks : 1

The circle passing through the intersection of the circles, $x^2 + y^2 - 6x = 0$ and $x^2 + y^2 - 4y = 0$, having its centre on the line, $2x - 3y + 12 = 0$, also passes through the point :

Options :

40503641002. (1, -3)

40503641003. (-3, 1)

40503641004. (-3, 6)

40503641005. (-1, 3)

Question Number : 65 Question Id : 40503611295 Question Type : MCQ Option Shuffling : Yes Display Question Number : Yes Is Question Mandatory : No Single Line Question Option : No Option Orientation : Vertical

Correct Marks : 4 Wrong Marks : 1

वृत्तों $x^2 + y^2 - 6x = 0$ तथा $x^2 + y^2 - 4y = 0$ के प्रतिच्छेदन बिंदुओं से हो कर जाने वाला वह वृत्त जिसका केंद्र, रेखा $2x - 3y + 12 = 0$ पर स्थित है, निम्न में से जिस बिंदु से भी हो कर जाता है, वह है :

Options :

40503641002. (1, -3)

40503641003. (-3, 1)

40503641004. (-3, 6)

40503641005. (-1, 3)

Question Number : 66 Question Id : 40503611296 Question Type : MCQ Option Shuffling : Yes Display Question Number : Yes Is Question Mandatory : No Single Line Question Option : No Option Orientation : Vertical

Correct Marks : 4 Wrong Marks : 1

Let $x=4$ be a directrix to an ellipse whose centre is at the origin and its eccentricity is

$\frac{1}{2}$. If $P(1, \beta)$, $\beta > 0$ is a point on this ellipse,

then the equation of the normal to it at P is :

Options :

40503641006. $4x - 3y = 2$

40503641007. $4x - 2y = 1$

40503641008. $8x - 2y = 5$

40503641009. $7x - 4y = 1$

Question Number : 66 Question Id : 40503611296 Question Type : MCQ Option Shuffling : Yes Display Question Number : Yes Is Question Mandatory : No Single Line Question Option : No Option Orientation : Vertical

Correct Marks : 4 Wrong Marks : 1

माना $x=4$ एक ऐसे दीर्घवृत्त की एक नियता है, जिसका

केंद्र मूल बिंदु पर है तथा जिसकी उत्केंद्रता $\frac{1}{2}$ है। यदि

$P(1, \beta)$, $\beta > 0$, इस दीर्घवृत्त पर स्थित एक बिंदु है, तो इसके P पर खींचे गए अभिलंब का समीकरण है :

Options :

40503641006. $4x - 3y = 2$

40503641007. $4x - 2y = 1$

40503641008. $8x - 2y = 5$

40503641009. $7x - 4y = 1$

Question Number : 67 Question Id : 40503611297 Question Type : MCQ Option Shuffling : Yes
Display Question Number : Yes Is Question Mandatory : No Single Line Question Option : No Option
Orientation : Vertical

Correct Marks : 4 Wrong Marks : 1

The distance of the point $(1, -2, 3)$ from
the plane $x - y + z = 5$ measured parallel to

the line $\frac{x}{2} = \frac{y}{3} = \frac{z}{-6}$ is :

Options :

40503641010. $\frac{1}{7}$

40503641011. 1

40503641012. 7

40503641013. $\frac{7}{5}$

Question Number : 67 Question Id : 40503611297 Question Type : MCQ Option Shuffling : Yes
Display Question Number : Yes Is Question Mandatory : No Single Line Question Option : No Option
Orientation : Vertical

Correct Marks : 4 Wrong Marks : 1

बिंदु $(1, -2, 3)$ की समतल $x - y + z = 5$ से रेखा

$\frac{x}{2} = \frac{y}{3} = \frac{z}{-6}$ के समांतर मापी गई दूरी है :

Options :

40503641010. $\frac{1}{7}$

40503641011. 1

40503641012. 7

40503641013. $\frac{7}{5}$

Question Number : 68 Question Id : 40503611298 Question Type : MCQ Option Shuffling : Yes
Display Question Number : Yes Is Question Mandatory : No Single Line Question Option : No Option
Orientation : Vertical

Correct Marks : 4 Wrong Marks : 1

In a game two players A and B take turns in throwing a pair of fair dice starting with player A and total of scores on the two dice, in each throw is noted. A wins the game if he throws a total of 6 before B throws a total of 7 and B wins the game if he throws a total of 7 before A throws a total of six. The game stops as soon as either of the players wins. The probability of A winning the game is :

Options :

40503641014. $\frac{5}{6}$

40503641015. $\frac{5}{31}$

40503641016. $\frac{31}{61}$

40503641017. $\frac{30}{61}$

Question Number : 68 Question Id : 40503611298 Question Type : MCQ Option Shuffling : Yes
Display Question Number : Yes Is Question Mandatory : No Single Line Question Option : No Option
Orientation : Vertical

Correct Marks : 4 Wrong Marks : 1

एक खेल में दो खिलाड़ी A तथा B बारी बारी से अनभिन्नत पासों के युग्म को फेंकते हैं, जबकि खिलाड़ी A खेल आरम्भ करता है, तथा प्रत्येक बार दोनों पासों पर आए अंकों का योग नोट किया जाता है। यदि B द्वारा फेंके गए पासों के अंकों का योग 7 आने से पहले A द्वारा फेंके गए पासों के अंकों का योग 6 आ जाता है, तो A जीतता है जबकि A द्वारा फेंके गए पासों के अंकों का योग 6 आने से पहले, B द्वारा फेंके गए पासों के अंकों का योग 7 आ जाता है, तो B जीतता है। किसी भी एक खिलाड़ी के जीतने पर खेल समाप्त हो जाता है। A के खेल को जीतने की प्रायिकता है :

Options :

40503641014. $\frac{5}{6}$

40503641015. $\frac{5}{31}$

40503641016. $\frac{31}{61}$

40503641017. $\frac{30}{61}$

Question Number : 69 Question Id : 40503611299 Question Type : MCQ Option Shuffling : Yes Display Question Number : Yes Is Question Mandatory : No Single Line Question Option : No Option Orientation : Vertical

Correct Marks : 4 Wrong Marks : 1

The angle of elevation of a cloud C from a point P, 200 m above a still lake is 30° . If the angle of depression of the image of C in the lake from the point P is 60° , then PC (in m) is equal to :

Options :

40503641018. 100

40503641019. $200\sqrt{3}$

40503641020. 400

40503641021. $400\sqrt{3}$

Question Number : 69 Question Id : 40503611299 Question Type : MCQ Option Shuffling : Yes Display Question Number : Yes Is Question Mandatory : No Single Line Question Option : No Option Orientation : Vertical

Correct Marks : 4 Wrong Marks : 1

एक स्थिर जल वाली झील के तल से 200 मीटर की ऊँचाई पर स्थित एक बिंदु P से एक बादल C का उन्नयन कोण 30° है। यदि C के झील में प्रतिबिंब का P से अवनयन कोण 60° है, तो PC (मीटरों में) है :

Options :

40503641018. 100

40503641019. $200\sqrt{3}$

40503641020. 400

40503641021. $400\sqrt{3}$

Question Number : 70 Question Id : 40503611300 Question Type : MCQ Option Shuffling : Yes Display Question Number : Yes Is Question Mandatory : No Single Line Question Option : No Option Orientation : Vertical

Correct Marks : 4 Wrong Marks : 1

Contrapositive of the statement :

'If a function f is differentiable at a , then it is also continuous at a ', is :

Options :

40503641022. If a function f is continuous at a , then it is differentiable at a .

40503641023. If a function f is continuous at a , then it is not differentiable at a .

40503641024. If a function f is not continuous at a ,
then it is not differentiable at a .

40503641025. If a function f is not continuous at a ,
then it is differentiable at a .

**Question Number : 70 Question Id : 40503611300 Question Type : MCQ Option Shuffling : Yes
Display Question Number : Yes Is Question Mandatory : No Single Line Question Option : No Option
Orientation : Vertical**

Correct Marks : 4 Wrong Marks : 1

कथन,

‘यदि एक फलन f , a पर अवकलनीय है, तो यह a पर
संतत भी है’

का प्रतिधनात्मक कथन है :

Options :

40503641022. यदि एक फलन f , a पर संतत है, तो यह a पर
अवकलनीय है।

40503641023. यदि एक फलन f , a पर संतत है, तो यह a पर
अवकलनीय नहीं है।

40503641024. यदि एक फलन f , a पर संतत नहीं है, तो यह a
पर अवकलनीय नहीं है।

40503641025. यदि एक फलन f , a पर संतत नहीं है, तो यह a
पर अवकलनीय है।

Sub-Section Number :

2

Sub-Section Id :

405036790

Question Shuffling Allowed :

Yes

**Question Number : 71 Question Id : 40503611301 Question Type : SA Display Question Number : Yes
Correct Marks : 4 Wrong Marks : 0**

If the variance of the following frequency distribution :

Class : 10-20 20-30 30-40

Frequency : 2 x 2

is 50, then x is equal to _____.

Response Type : Numeric

Evaluation Required For SA : Yes

Show Word Count : Yes

Answers Type : Range

Text Areas : PlainText

Possible Answers :

5 to 5.002

Question Number : 71 Question Id : 40503611301 Question Type : SA Display Question Number : Yes

Correct Marks : 4 Wrong Marks : 0

यदि निम्न बारंबारता बंटन

वर्ग : 10-20 20-30 30-40

बारंबारता : 2 x 2

का प्रसरण 50 है, तो x का मान है _____.

Response Type : Numeric

Evaluation Required For SA : Yes

Show Word Count : Yes

Answers Type : Range

Text Areas : PlainText

Possible Answers :

5 to 5.002

Question Number : 72 Question Id : 40503611302 Question Type : SA Display Question Number : Yes

Correct Marks : 4 Wrong Marks : 0

A test consists of 6 multiple choice questions, each having 4 alternative answers of which only one is correct. The number of ways, in which a candidate answers all six questions such that exactly four of the answers are correct, is _____.

Response Type : Numeric

Evaluation Required For SA : Yes

Show Word Count : Yes

Answers Type : Range

Text Areas : PlainText

Possible Answers :

5 to 5.002

Question Number : 72 Question Id : 40503611302 Question Type : SA Display Question Number : Yes

Correct Marks : 4 Wrong Marks : 0

एक परीक्षा में 6 बहुविकल्पी प्रश्न हैं तथा प्रत्येक प्रश्न के उत्तर के लिए 4 विकल्प हैं जिनमें से केवल एक सही है। एक परीक्षार्थी द्वारा सभी 6 प्रश्नों के उत्तर इस प्रकार देने, ताकि उसके ठीक 4 प्रश्नों के उत्तर सही हों, के तरीकों की संख्या है _____।

Response Type : Numeric

Evaluation Required For SA : Yes

Show Word Count : Yes

Answers Type : Range

Text Areas : PlainText

Possible Answers :

5 to 5.002

Question Number : 73 Question Id : 40503611303 Question Type : SA Display Question Number : Yes

Correct Marks : 4 Wrong Marks : 0

Let $\{x\}$ and $[x]$ denote the fractional part of x and the greatest integer $\leq x$ respectively of a real number x . If

$$\int_0^n \{x\} dx, \int_0^n [x] dx \quad \text{and} \quad 10(n^2 - n),$$

$(n \in \mathbb{N}, n > 1)$ are three consecutive terms of a G.P., then n is equal to _____.

Response Type : Numeric

Evaluation Required For SA : Yes

Show Word Count : Yes

Answers Type : Range

Text Areas : PlainText

Possible Answers :

5 to 5.002

Question Number : 73 Question Id : 40503611303 Question Type : SA Display Question Number : Yes

Correct Marks : 4 Wrong Marks : 0



माना $\{x\}$ तथा $[x]$, क्रमशः एक वास्तविक संख्या x के भिन्नात्मक भाग तथा महत्तम पूर्णांक $\leq x$, को दर्शाते हैं। यदि $\int_0^n \{x\} dx$, $\int_0^n [x] dx$ तथा $10(n^2 - n)$, ($n \in \mathbb{N}$, $n > 1$) एक गुणोत्तर श्रेणी के तीन क्रमागत पद हैं, तो n का मान है _____।

Response Type : Numeric

Evaluation Required For SA : Yes

Show Word Count : Yes

Answers Type : Range

Text Areas : PlainText

Possible Answers :

5 to 5.002

Question Number : 74 **Question Id :** 40503611304 **Question Type :** SA Display **Question Number :** Yes
Correct Marks : 4 **Wrong Marks :** 0

Let PQ be a diameter of the circle $x^2 + y^2 = 9$.
If α and β are the lengths of the perpendiculars from P and Q on the straight line, $x + y = 2$ respectively, then the maximum value of $\alpha\beta$ is _____.

Response Type : Numeric

Evaluation Required For SA : Yes

Show Word Count : Yes

Answers Type : Range

Text Areas : PlainText

Possible Answers :

5 to 5.002

Question Number : 74 **Question Id :** 40503611304 **Question Type :** SA Display **Question Number :** Yes
Correct Marks : 4 **Wrong Marks :** 0

माना PQ वृत्त $x^2 + y^2 = 9$ का एक व्यास है। यदि P तथा Q से रेखा $x + y = 2$ पर खींचे गए लंबों की लंबाइयाँ क्रमशः α तथा β हैं, तो $\alpha\beta$ का अधिकतम मान है _____।

Response Type : Numeric

Evaluation Required For SA : Yes

Show Word Count : Yes

Answers Type : Range

Text Areas : PlainText

Possible Answers :

5 to 5.002

Question Number : 75 Question Id : 40503611305 Question Type : SA Display Question Number : Yes

Correct Marks : 4 Wrong Marks : 0

If $\vec{a} = 2\hat{i} + \hat{j} + 2\hat{k}$, then the value of

$$\left| \hat{i} \times (\vec{a} \times \hat{i}) \right|^2 + \left| \hat{j} \times (\vec{a} \times \hat{j}) \right|^2 +$$

$$\left| \hat{k} \times (\vec{a} \times \hat{k}) \right|^2 \text{ is equal to } \underline{\hspace{2cm}}.$$

Response Type : Numeric

Evaluation Required For SA : Yes

Show Word Count : Yes

Answers Type : Range

Text Areas : PlainText

Possible Answers :

5 to 5.002

Question Number : 75 Question Id : 40503611305 Question Type : SA Display Question Number : Yes

Correct Marks : 4 Wrong Marks : 0

यदि $\vec{a} = 2\hat{i} + \hat{j} + 2\hat{k}$ है, तो

$$\left| \hat{i} \times (\vec{a} \times \hat{i}) \right|^2 + \left| \hat{j} \times (\vec{a} \times \hat{j}) \right|^2 +$$

$$\left| \hat{k} \times (\vec{a} \times \hat{k}) \right|^2 \text{ का मान है } \underline{\hspace{2cm}}।$$

Response Type : Numeric

Evaluation Required For SA : Yes

Show Word Count : Yes

Answers Type : Range

Text Areas : PlainText

Possible Answers :

5 to 5.002