

JAM 2006

MASTER IN COMPUTER APPLICATIONS TEST PAPER

1. The order of 2 in the field \mathbb{Z}_{29} is

- (A) 2
- (B) 14
- (C) 28
- (D) 29

2. If $\vec{u}(t) = u_1(t)\mathbf{i} + u_2(t)\mathbf{j} + u_3(t)\mathbf{k}$ is a unit vector and $\frac{d\vec{u}}{dt} \neq 0$, then the angle between $\vec{u}(t)$ and $\frac{d\vec{u}}{dt}$ is

- (A) 0
- (B) $\frac{\pi}{4}$
- (C) $\frac{\pi}{3}$
- (D) $\frac{\pi}{2}$

3. The missing terms in the table

x	0	1	2	3	4	5	6
$y(x)$	0	3	0	3	0		

using a 4th degree interpolating polynomial are

- (A) $(-45, -192)$
- (B) $(-45, -576)$
- (C) $(-90, -192)$
- (D) $(-90, 576)$

4. The differential equation

$$2ydx - (3y - 2x)dy = 0$$

is

- (A) exact and homogeneous but not linear
- (B) homogeneous and linear but not exact
- (C) exact and linear but not homogeneous
- (D) exact, homogeneous and linear

5. For $f(x) = (1 + \sin x) \cos x$, where $0 \leq x < 2\pi$, which of the following statements is true

- (A) $f(x)$ has a local maxima at $x = \frac{\pi}{6}$
- (B) $f(x)$ has a local minima at $x = \frac{\pi}{3}$
- (C) $f(x)$ has a local maxima at $x = \frac{5\pi}{3}$
- (D) $f(x)$ has a local minima at $x = \frac{3\pi}{4}$

6. Let W be the subspace spanned by $(2i, 0, 1, 2i)$, $(0, 2i - 2, i - 3, 0)$, $(-i, 1, 0, i)$ and $(1, 1, 1, 1)$ in \mathbb{C}^4 over \mathbb{C} . The dimension of W over \mathbb{C} is

- (A) 1
- (B) 2
- (C) 3
- (D) 4

7. If

$$3 \int_0^{2h} f(x) dx = h[a f(0) + b f(h) + c f(2h)]$$

for all polynomials $f(x)$ of degree ≤ 2 , and $h > 0$, then (a, b, c) is

- (A) (1, 2, 1)
- (B) (1, 4, 1)
- (C) (2, 2, 2)
- (D) (2, 4, 1)

8. The value of the integral $\int_0^\infty \int_x^\infty \frac{e^{-y}}{y} dy dx$ is

- (A) 0
- (B) 1
- (C) 2
- (D) ∞

9. The function $f(x, y) = x^3 + 3xy^2 - 4y^3 - 15x$ has a local
- (A) minima at $(-\sqrt{5}, 0)$
 - (B) minima at $(\sqrt{5}, \sqrt{5})$
 - (C) maxima at $(\sqrt{5}, 0)$
 - (D) maxima at $(-\sqrt{5}, 0)$
10. The remainder obtained on dividing 2^{1680} by 1763 is
- (A) 1
 - (B) 3
 - (C) 13
 - (D) 31
11. The orthogonal trajectories of the curves $y = 3x^3 + x + c$ are
- (A) $2 \tan^{-1} 3x + 3 \ln |y| = k$
 - (B) $3 \tan^{-1} 3x + 2 \ln |y| = k$
 - (C) $3 \tan^{-1} 3x - 2 \ln |y| = k$
 - (D) $3 \ln |x| - 2 \tan^{-1} 3y = k$
12. The iterative formula to compute the reciprocal of a given positive real number α using Newton-Raphson method is
- (A) $x_{n+1} = x_n (2 - \alpha x_n)$
 - (B) $x_{n+1} = x_n (2 + \alpha x_n)$
 - (C) $x_{n+1} = x_n^2 (2 - \alpha x_n)$
 - (D) $x_{n+1} = x_n^2 (2 + \alpha x_n)$
13. If $y_1'(x) = 3y_1(x) + 4y_2(x)$ and $y_2'(x) = 4y_1(x) + 3y_2(x)$, then $y_1(x)$ is
- (A) $c_1 e^x + c_2 e^{7x}$
 - (B) $c_1 e^x + c_2 e^{-7x}$
 - (C) $c_1 e^{-x} + c_2 e^{7x}$
 - (D) $c_1 e^{-x} + c_2 e^{-7x}$

14. Let G be a group of order 8 generated by a and b such that $a^4 = b^2 = 1$ and $ba = a^3b$.
The order of the center of G is
- (A) 1
(B) 2
(C) 4
(D) 8
15. The general solution of the differential equation

$$(x + y - 3)dx - (2x + 2y + 1)dy = 0$$
is
- (A) $\ln|3x + 3y - 2| + 3x + 6y = k$
(B) $\ln|3x + 3y - 2| - 3x - 6y = k$
(C) $7\ln|3x + 3y - 2| + 3x + 6y = k$
(D) $7\ln|3x + 3y - 2| - 3x + 6y = k$
16. The surface area of the solid generated by revolving the line segment $y = x + 2$ for $0 \leq x \leq 1$ about the line $y = 2$ is
- (A) $\sqrt{2}\pi$
(B) 2π
(C) $2\sqrt{2}\pi$
(D) 4π
17. Let $g(x)$ be the Maclaurin's expansion of $\sin 2x$. If $\sin 2x$ is approximated by $g(x)$ so that the error is at most $\frac{1250}{3} \times 10^{-4}$ for $0 \leq x \leq \frac{1}{2}$, then the minimum number of non-zero terms in $g(x)$ is
- (A) 2
(B) 3
(C) 4
(D) 5
18. Let $f(x) = x^2 + 1$, $g(x) = x^3 + x^2 + 1$ and $h(x) = x^4 + x^2 + 1$. Then
- (A) $f(x)$ and $g(x)$ are reducible over \mathbb{Z}_2
(B) $g(x)$ and $h(x)$ are reducible over \mathbb{Z}_2
(C) $f(x)$ and $h(x)$ are reducible over \mathbb{Z}_2
(D) $f(x), g(x)$ and $h(x)$ are reducible over \mathbb{Z}_2

19. The general solution of the differential equation

$$y''(x) - 4y'(x) + 8y(x) = 10e^x \cos x$$

is

(A) $e^{2x}(k_1 \cos 2x + k_2 \sin 2x) + e^x(2 \cos x + \sin x)$

(B) $e^{2x}(k_1 \cos 2x + k_2 \sin 2x) + e^x(2 \cos x - \sin x)$

(C) $e^{-2x}(k_1 \cos 2x + k_2 \sin 2x) - e^x(2 \cos x - \sin x)$

(D) $e^{-2x}(k_1 \cos 2x + k_2 \sin 2x) + e^x(2 \cos x + \sin x)$

20. Let $\sigma = \begin{pmatrix} 1 & 2 & 3 & 4 & 5 & 6 & 7 & 8 & 9 & 10 & 11 & 12 \\ 2 & 10 & 8 & 5 & 9 & 3 & 6 & 11 & 4 & 12 & 1 & 7 \end{pmatrix}$. The cardinality of the orbit of 2 under σ is

(A) 3

(B) 6

(C) 9

(D) 12

21. The value of the integral $\int_0^1 \frac{x}{x^2 + 10} dx$ using Simpson's $\frac{1}{3}$ rule with $h = 0.5$ is

(A) $\frac{41}{902}$

(B) $\frac{43}{902}$

(C) $\frac{45}{902}$

(D) $\frac{47}{902}$

22. Let $f(x, y) = \ln \sqrt{x+y}$ and $g(x, y) = \sqrt{x+y}$. Then the value of $\nabla^2(fg)$ at $(1,0)$ is

(A) $-\frac{1}{2}$

(B) 0

(C) $\frac{1}{2}$

(D) 1

23. The general solution of the differential equation

$$(6x^2 - e^{-y^2})dx + 2xye^{-y^2} dy = 0$$

is

(A) $x^2(2x - e^{-y^2}) = c$

(B) $x^2(2x + e^{-y^2}) = c$

(C) $x(2x^2 + e^{-y^2}) = c$

(D) $x(2x^2 - e^{-y^2}) = c$

24. If

$$f(x, y) = \begin{cases} \frac{x^3}{x^2 + y^2}, & (x, y) \neq (0, 0) \\ 0, & \text{otherwise} \end{cases}$$

then at $(0, 0)$

(A) $\frac{\partial f}{\partial x}$ and $\frac{\partial f}{\partial y}$ exist and are equal

(B) $\frac{\partial f}{\partial x}$ and $\frac{\partial f}{\partial y}$ exist but not equal

(C) $\frac{\partial f}{\partial x}$ exists but $\frac{\partial f}{\partial y}$ does not

(D) $\frac{\partial f}{\partial y}$ exists but $\frac{\partial f}{\partial x}$ does not

25. Two teams A and B play a series of four matches. If the probability that team A wins a match is $\frac{2}{3}$, then the probability that team A wins three matches, loses one and the third win occurs in the fourth match is

(A) $\frac{8}{27}$

(B) $\frac{16}{27}$

(C) $\frac{8}{81}$

(D) $\frac{32}{81}$

26. The function

$$f(x) = \begin{cases} x^a \sin \frac{1}{x}, & x \neq 0 \\ 0, & x = 0 \end{cases}$$

is differentiable at $x = 0$ for all a in the interval

(A) $(-\infty, 1]$

(B) $(-1, \infty)$

(C) $(1, \infty)$

(D) $[1, \infty)$

27. A fair coin is tossed twice. Let A be the event that at least one tail appears and B be the event that both head and tail appear. Then $P(A/B)$, the probability of A given B , is

- (A) $\frac{1}{4}$
- (B) $\frac{1}{2}$
- (C) $\frac{2}{3}$
- (D) 1

28. The value of $f(5)$ using Lagrange's interpolation formula, given

x	0	1	4	6
$F(x)$	1	-1	1	-1

is

- (A) $-\frac{3}{2}$
- (B) -1
- (C) 1
- (D) $\frac{3}{2}$

29. Let F be a field. Given below are six statements about F .

1. F is a skew field
2. F is a group with respect to multiplication
3. F is an integral domain
4. F has zero divisors
5. F has no zero divisors
6. Only ideals of F are $\{0\}$ and itself

In which of the following options all the statements are correct?

- (A) 1, 2, 3
- (B) 1, 3, 5
- (C) 2, 4, 6
- (D) 4, 5, 6

30. The work done by the force $\vec{p} = 3\vec{i} - 2\vec{j} + 4\vec{k}$ acting on a particle, if the particle is displaced from $A(8, -2, -3)$ to $B(-2, 0, 6)$ along the line segment AB , is

- (A) 0
- (B) 2
- (C) 3.5
- (D) 4.2

31. If $8x - y = 15$ is a tangent at $(2, 1)$ to the curve $y = x^3 + ax^2 + b$, then (a, b) is
- (A) $(1, 3)$
 (B) $(-1, 3)$
 (C) $(1, -3)$
 (D) $(-1, -3)$

32. The entire area bounded by the curve $r^2 = a \cos 2\theta$ is
- (A) a
 (B) $2a$
 (C) πa
 (D) $2\pi a$

33. The inverse of the matrix

$$\begin{bmatrix} 1 & 0 & 0 & 0 & 0 \\ 1 & 1 & 0 & 0 & 0 \\ 1 & 0 & 1 & 0 & 0 \\ 1 & 0 & 0 & 1 & 0 \\ 1 & 0 & 0 & 0 & 1 \end{bmatrix}$$

is

(A) $\begin{bmatrix} 1 & 0 & 0 & 0 & 0 \\ 1 & -1 & 0 & 0 & 0 \\ 1 & 0 & -1 & 0 & 0 \\ 1 & 0 & 0 & -1 & 0 \\ 1 & 0 & 0 & 0 & -1 \end{bmatrix}$

(B) $\begin{bmatrix} 1 & 0 & 0 & 0 & 0 \\ -1 & 1 & 0 & 0 & 0 \\ 1 & -1 & 0 & 0 & 0 \\ -1 & 0 & -1 & 0 & 0 \\ 1 & 0 & 0 & -1 & 0 \end{bmatrix}$

(C) $\begin{bmatrix} 1 & 0 & 0 & 0 & 0 \\ -1 & 1 & 0 & 0 & 0 \\ -1 & 0 & 1 & 0 & 0 \\ -1 & 0 & 0 & 1 & 0 \\ -1 & 0 & 0 & 0 & 1 \end{bmatrix}$

$$(D) \begin{bmatrix} 1 & 0 & 0 & 0 & 0 \\ -1 & 1 & 0 & 0 & 0 \\ -1 & 0 & 1 & 0 & 0 \\ 1 & 0 & 0 & -1 & 0 \\ 1 & 0 & 0 & 0 & -1 \end{bmatrix}$$

34. Suppose that 20 misprints are distributed randomly in a book of 900 pages. Assuming Poisson distribution, the probability that a chapter of 30 pages contains 2 misprints is

(A) $\frac{2}{9}e^{-2/3}$

(B) $\frac{2}{9}e^{-3/2}$

(C) $\frac{9}{8}e^{-2/3}$

(D) $\frac{9}{8}e^{-3/2}$

35. The double integral $\int_1^2 \int_x^{2x} f(x, y) dy dx$ under the transformation $x = u(1-v)$, $y = uv$

is transformed into

(A) $\int_{1/2}^{2/3} \int_{1/(1-v)}^{2/(1-v)} f(u-uv, uv) dudv$

(B) $\int_{1/2}^{2/3} \int_{1/(1-v)}^{2/(1-v)} f(u-uv, uv) u dudv$

(C) $\int_{1/2}^{2/3} \int_{1/(1-v)}^{2/(1-v)} f(u-uv, uv) v dudv$

(D) $\int_{2/3}^1 \int_{1/(1-v)}^{2/(1-v)} f(u-uv, uv) u dudv$

36. If ω is a non-real cube root of unity, then the eigenvalues of the matrix

$$\begin{pmatrix} 1 & 1 & 1 \\ 1 & \omega & \omega^2 \\ 1 & \omega^2 & \omega^4 \end{pmatrix} \begin{pmatrix} 1 & 0 & 0 \\ 0 & -1 & 0 \\ 0 & 0 & 0 \end{pmatrix} \begin{pmatrix} 1 & 1 & 1 \\ 1 & 1/\omega & 1/\omega^2 \\ 1 & 1/\omega^2 & 1/\omega^4 \end{pmatrix}$$

are

(A) 1, -1, 0

(B) $\frac{1}{3}, -\frac{1}{3}, 0$

(C) 1, ω , ω^2

(D) 3, -3, 0

37. The area bounded by the curve $y = (x+1)^2$, its tangent at $(1, 4)$ and the x -axis is
- (A) $\frac{1}{3}$
 (B) $\frac{2}{3}$
 (C) 1
 (D) $\frac{4}{3}$
38. Let V and W be vector spaces over a field F with $\dim_F V = m$ and $\dim_F W = n$, where m and n both are finite. Then $\dim_F \text{Hom}(V, W)$ is
- (A) $m + n$
 (B) $|m - n|$
 (C) mn
 (D) $\frac{m}{n}$
39. Which of the following is a unit normal vector to the surface $z = xy$ at $P(2, -1, -1)$?
- (A) $\frac{\mathbf{i} - 2\mathbf{j} + \mathbf{k}}{\sqrt{6}}$
 (B) $\mathbf{i} - 2\mathbf{j} + \mathbf{k}$
 (C) $-\mathbf{i} + 2\mathbf{j} + \mathbf{k}$
 (D) $\frac{-\mathbf{i} + 2\mathbf{j} + \mathbf{k}}{\sqrt{6}}$
40. The nullity of the matrix

$$\begin{pmatrix} 1-i & 0 & i & i-1 \\ 0 & 2-i & -2 & 2 \\ -2 & -4 & 3-i & -3 \\ 1+i & 2+i & -1 & 2-i \end{pmatrix}$$

is

- (A) 1
 (B) 2
 (C) 3
 (D) 4

41. Arc length of the curve $y = x^{3/2}$, $z = 0$ from $(0, 0, 0)$ to $(4, 8, 0)$ is
- (A) $\frac{8}{27}(10^{3/2} + 1)$
- (B) $\frac{8}{27}(10^{3/2} - 2)$
- (C) $\frac{8}{27}(10^{3/2} - 1)$
- (D) $\frac{8}{27}(10^{3/2} + 2)$
42. The integral $\int_1^{\infty} \frac{dx}{x^2(1+e^x)}$
- (A) converges and has value < 1
- (B) converges and has value equal to 1
- (C) converges and has value > 1
- (D) diverges
43. Let (n, p) and λ be the parameters of binomial and Poisson distributions respectively. Consider the statements
- P. The mean of the binomial distribution is np
- Q. The standard deviation of the binomial distribution is $np(1-p)$
- R. The mean of the Poisson distribution is λ
- S. The variance of the Poisson distribution is λ
- Which of the following group of statements is correct?
- (A) P, R, S
- (B) P, Q, S
- (C) P, Q, R
- (D) P, Q, R, S
44. The order of the quotient group $\mathbb{Z}_8 \times \mathbb{Z}_9 \times \mathbb{Z}_{18} / \langle (2, 2, 2) \rangle$ is
- (A) 18
- (B) 36
- (C) 72
- (D) 144
45. Which of the following sets is NOT a convex set?
- (A) $\{(x, y) \mid 4x^2 + y^2 \leq 9, x - y \leq 1\}$
- (B) $\{(x, y) \mid 4x^2 + y^2 \leq 9, x - y \geq 1\}$
- (C) $\{(x, y) \mid 4x^2 + y^2 \geq 9, x - y \geq 5\}$
- (D) $\{(x, y) \mid 4x^2 + y^2 \geq 9, x - y \leq 5\}$

46. The volume of the smaller part of the sphere $x^2 + y^2 + z^2 = 1$ when cut off by the plane $z = \frac{1}{2}$ is

(A) $\frac{5\pi}{24}$

(B) $\frac{5\pi}{12}$

(C) $\frac{5\pi}{8}$

(D) $\frac{5\pi}{3}$

47. Let $M = \begin{pmatrix} 1 & 1+i & 2-i \\ 1-i & 2 & 3+i \\ 2+i & 3-i & 3 \end{pmatrix}$. If $B = \begin{pmatrix} x_1 & y_1 & z_1 \\ x_2 & y_2 & z_2 \\ x_3 & y_3 & z_3 \end{pmatrix}$, where $\begin{pmatrix} x_1 \\ x_2 \\ x_3 \end{pmatrix}$, $\begin{pmatrix} y_1 \\ y_2 \\ y_3 \end{pmatrix}$ and $\begin{pmatrix} z_1 \\ z_2 \\ z_3 \end{pmatrix}$

are linearly independent eigenvectors of M , then the main diagonal of the matrix $B^{-1}MB$ has

(A) exactly one real entry

(B) exactly two real entries

(C) exactly three real entries

(D) no real entry

48. The linear programming problem

$$\text{Maximize } z = 2x + 3y$$

subject to

$$2x + 3y \leq 12$$

$$2x - 3y \leq 0$$

$$y \leq 2$$

$$x, y \geq 0$$

has

(A) no feasible solution

(B) unique optimal solution

(C) alternative optimal solutions

(D) unbounded solution

49. For the set $W = \{ (x, 1, z) \in \mathbb{R}^3 \}$, consider the statements

- P. W is not closed under vector addition
- Q. W is closed under scalar multiplication
- R. W has an additive identity
- S. W is not a subspace of \mathbb{R}^3

Which of the following group of statements is true?

- (A) P, R
- (B) Q, R
- (C) P, S
- (D) Q, S

50. The number of values of λ for which the system of equations

$$\begin{aligned}\lambda x + (\lambda + 3)y &= 10z \\ (\lambda - 1)x + (\lambda - 2)y &= 5z \\ 2x + (\lambda + 4)y &= \lambda z\end{aligned}$$

has infinitely many solutions, is

- (A) 1
- (B) 2
- (C) 3
- (D) infinite

51. Let A and B be events with $P(A) = \frac{2}{3}$, $P(B) = \frac{1}{2}$ and $P(A \cap B) = \frac{1}{3}$. Match lists

I and II and select the correct answer.

List I	List II
1. $P(A \cap B^c)$	P. $\frac{2}{3}$
2. $P(A \cup B^c)$	Q. $\frac{1}{3}$
3. $P(A^c \cap B^c)$	R. $\frac{5}{6}$
4. $P(A^c \cup B^c)$	S. $\frac{1}{6}$

- (A) (1, P), (2, Q), (3, R), (4, S)
- (B) (1, R), (2, Q), (3, S), (4, P)
- (C) (1, Q), (2, R), (3, S), (4, P)
- (D) (1, Q), (2, R), (3, P), (4, S)

52. Consider the statements

- (P) If a linear programming problem has only one optimal solution, then this solution is an extreme point of the feasible region.
- (Q) A linear programming problem either is infeasible or has at least one optimal solution.
- (R) A linear programming problem can have exactly two optimal solutions.
- (S) A feasible linear programming problem has an optimal solution or unbounded solution.

Which of the following group of statements is correct?

- (A) P, Q
- (B) P, R
- (C) R, S
- (D) P, S

53. For the linear programming problem

$$\text{Minimize } z = x - y$$

subject to

$$-2 \leq x \leq 3$$

$$-3 \leq y \leq 2$$

the minimum value of z is

- (A) -6
- (B) -5
- (C) -4
- (D) 1

54. Let P be a set having $n > 10$ elements. The number of subsets of P having odd number of elements is

- (A) $2^{n-1} - 1$
- (B) 2^{n-1}
- (C) $2^{n-1} + 1$
- (D) $2^n - 1$

55. Let P be the set of all planes in \mathbb{R}^3 . The relation being normal in P is

- (A) symmetric and transitive
- (B) symmetric and reflexive
- (C) symmetric but not transitive
- (D) transitive but not reflexive

56. For sets P, Q, R which of the following is NOT correct?

- (A) $(P \cup Q) \cap R = (P \cap R) \cup (Q \cap R)$
- (B) $(P \setminus Q) \setminus R = (P \setminus R) \setminus (Q \setminus R)$
- (C) If $P \cup Q = P \cup R$, then $Q = R$
- (D) $P \times (Q \cap R) = (P \times Q) \cap (P \times R)$

57. If $a \otimes b = a + b - ab$ for all $a, b \in \mathbb{R}$, then which of the following statements is correct?
- (A) (\mathbb{R}, \otimes) is a group
 (B) $(\mathbb{R} \setminus \{0\}, \otimes)$ is a group
 (C) $(\mathbb{R} \setminus \{1\}, \otimes)$ is a group
 (D) $(\mathbb{R} \setminus \{-1\}, \otimes)$ is a group
58. $(\vec{U} \times \vec{V}) \times \vec{W}$ is equal to
- (A) $(\vec{U} \cdot \vec{W})\vec{V} + (\vec{U} \cdot \vec{V})\vec{W}$
 (B) $(\vec{U} \cdot \vec{W})\vec{V} - (\vec{V} \cdot \vec{W})\vec{U}$
 (C) $(\vec{V} \cdot \vec{W})\vec{U} - (\vec{U} \cdot \vec{W})\vec{V}$
 (D) $(\vec{U} \cdot \vec{W})\vec{V} + (\vec{V} \cdot \vec{W})\vec{U}$
59. The addition of the BCD numbers given below
 01100111 and 01010011
 is
- (A) 000100100000
 (B) 000110100000
 (C) 000101100000
 (D) 000101010000
60. The output of the following program
- ```
main()
{ int a[] = { 2,3,4,6,5};
 int *p = a;
 for (int i = 0; i < 5; i++)
 printf("%d,",++*p);
}
```
- is
- (A) 3, 4, 5, 6, 7  
 (B) 3, 4, 5, 7, 6  
 (C) 3, 4, 6, 5, 0  
 (D) 3, 4, 5, 6, 6
61. The multiplication of numbers  $(47)_8$  and  $(52)_8$  is
- (A)  $(3144)_8$   
 (B)  $(3146)_8$   
 (C)  $(4147)_8$   
 (D)  $(4146)_8$



62. The output of the following program

```
main()
{ int a = 10; b = 4;
 if(a&1 || b&1)
 printf("Hello");
 else printf("Welcome");
}
```

is

- (A) Hello
- (B) WelcomeHello
- (C) HelloWelcome
- (D) Welcome

63. The sequence 10000, 121, 100, 31, 24, \_\_\_\_, 20 represent a number  $x$  with respect to different bases. The missing number in this sequence is

- (A) 22
- (B) 21
- (C) 16
- (D) 10

64. The program

```
main()
{ int a = 256, *p=&a;
 printf("%d",*p>>5);
}
```

prints

- (A) 2
- (B) 4
- (C) 6
- (D) 8

65. If  $(41)_6 = (121)_b$  then  $b$  is

- (A) 1
- (B) 2
- (C) 3
- (D) 4

66. The output of the following program

```
main()
{
 int a[] = "computation";
 char *p = a, b=' ';
 for (int i = 1; i < 12; i++)
 if(i%4) continue;
 else a[i]=b;
 puts(p);
}
```

is

- (A) comp
- (B) comp tat on
- (C) com utat on
- (D) comp tati n



67. If  $a^n = \begin{cases} (a^{n/2})^2, & n \text{ even} \\ aa^{n-1}, & \text{otherwise} \end{cases}$

then to compute  $a^{27}$ , the minimum number of multiplications and squaring required respectively are

- (A) 3 and 4
- (B) 4 and 3
- (C) 27 and 14
- (D) 26 and 13

68. The output of the following logic circuit diagram for  $x = 0, y = 1, z = 1, u = 0, v = 1, w = 0$

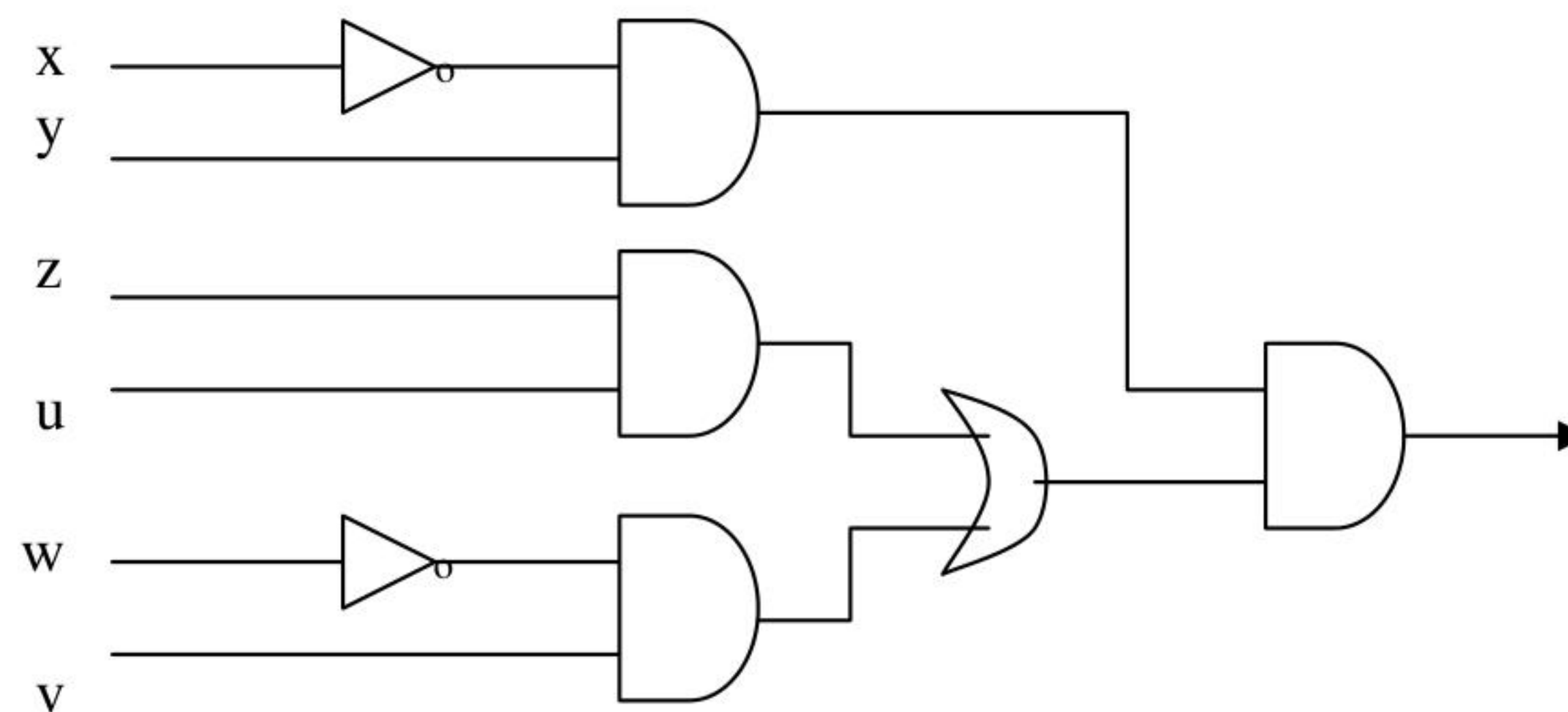

is

- (A) 0
- (B) 00
- (C) 1
- (D) 10

69. The following function computes

```
int f(int p)
{
 static int x = 10;
 if(x == 1) return 1;
 if(x > 0)
 { x--;
 return p*f(p);
 }
}
```

- (A)  $p^9$
- (B)  $p^{10}$
- (C)  $10^{p-1}$
- (D)  $10^p$



70. Which of the following combinations is invalid in SR flip-flops?

- (A)  $S = 0, R = 0$
- (B)  $S = 0, R = 1$
- (C)  $S = 1, R = 0$
- (D)  $S = 1, R = 1$

71. What does the following function return ?

```
int f()
{
 int a, b, c;
 if(a > b)
 if(a > c)
 if(c > b) return c;
 else return b;
 else return a;
 else if(c > a)
 if(c > b) return b;
 else return c;
 else return a;
}
```

- (A) minimum(a, b, c)
- (B) maximum(a, b, c)
- (C) middle(a, b, c)
- (D) gcd(a, b, c)

72. What does the following function print?

```
void f()
{
 char p;
 if((p = getchar()) != '\n') f();
 putchar(p);
 return;
}
```

- (A) reverse of the given characters
- (B) characters in the given order
- (C) characters in the given order without the first character
- (D) reverse of the given characters without the last character



73. The output of the following program

```
main()
{
 int i = 4, j = 5;
 while(i <= 6)
 {
 if(j >= 100) j = j - 2;
 else j = i*j; j++; i++;
 }
 printf("%d, %d", i++, j);
}
```

is

- (A) 6, 105
  - (B) 6, 106
  - (C) 7, 105
  - (D) 7, 106
74. What is the output of the following program?

```
main()
{
 int a, b, *p1, *p2, y;
 a = 3; b = 4; p1 = &a; p2 = &b;
 y = 4*-*p2/ *p1+10;
 a* = b* = a* = y;
 printf("%d,%d,%d",y,a,b);
}
```

- (A) 5, 60, 900
  - (B) 5, 900, 60
  - (C) 60, 900, 5
  - (D) 900, 60, 5
75. From the following flip-flops
- JK flip-flop
  - P. SR flip-flop
  - Q. D flip-flop
  - R. T flip-flop

The pair of flip-flops which uses only one input is

- (A) (P, S)
- (B) (Q, R)
- (C) (R, S)
- (D) (P, R)



76. Match list I and list II and select the correct group of matching

List I

List II

P. optical memory

1. operating system

Q. ADA

2. USB port

R. Unix

3. programming language

S. memory stick

4. CD-ROM

(A) (P, 4), (Q, 3), (R, 1), (S, 2)

(B) (P, 3), (Q, 2), (R, 4), (S, 1)

(C) (P, 2), (Q, 1), (R, 3), (S, 4)

(D) (P, 1), (Q, 4), (R, 2), (S, 3)

77. ASCII stands for

(A) American Standard Code for International Interchange

(B) American Scientific Code for Information Interchange

(C) American Standard Code for Intelligence Interchange

(D) American Standard Code for Information Interchange

78. Match list I and list II and select the correct group of matching

List I

List II

P. Wolfram

1. LISP

Q. Kennighnan & Ritchie

2. C++

R. John McCarthy

3. C

S. Stroustrup

4. MATHEMATICA

(A) (P, 1), (Q, 2), (R, 3), (S, 4)

(B) (P, 2), (Q, 3), (R, 4), (S, 1)

(C) (P, 3), (Q, 4), (R, 1), (S, 2)

(D) (P, 4), (Q, 3), (R, 1), (S, 2)

79. Consider the following pseudo code

1. for  $i \leftarrow 1$  to 9

2.      $x = 1$

3. for  $j \leftarrow i$  to 10

4.      $y = 2$

The number of times the statement 2 and statement 4 executed respectively are

(A) (9, 9)

(B) (9, 54)

(C) (9, 90)

(D) (10, 54)



80. Consider a tri-diagonal matrix  $A = (a_{ij})_{n \times n}$ . If the diagonal elements are stored in a linear array B as  $B[1] = a_{11}$ ,  $B[2] = a_{12}$ ,  $B[3] = a_{13}$ ,  $B[4] = a_{22}$ , ... , then the relation in terms of  $m$ ,  $k$  and  $l$  such that  $B[m] = a_{kl}$  is
- (A)  $m = k + l - 2$   
 (B)  $m = 2k - l + 2$   
 (C)  $m = 2k + l - 2$   
 (D)  $m = k + 2l - 1$
81. Match list I and list II and select the correct group of matching
- | List I          | List II       |
|-----------------|---------------|
| P. RAM          | 1. Hz         |
| Q. CPU speed    | 2. MB         |
| R. Monitor      | 3. Bytes/sec. |
| S. CD-ROM speed | 4. inch       |
- (A) (P, 2), (Q, 1), (R, 4), (S, 3)  
 (B) (P, 1), (Q, 2), (R, 3), (S, 4)  
 (C) (P, 3), (Q, 4), (R, 2), (S, 1)  
 (D) (P, 4), (Q, 3), (R, 1), (S, 2)
82. Which of the following is NOT a language processor?
- (A) compiler  
 (B) loader  
 (C) interpreter  
 (D) assembler
83. Which of the following is NOT a internet protocol?
- (A) LTP  
 (B) SMTP  
 (C) HTTP  
 (D) ATM
84. Which of the following statements in a Boolean algebra is NOT correct?
- (A)  $A + A = A$   
 (B)  $A \cdot A = A$   
 (C)  $A + 1 = A$   
 (D)  $A + AB = A$
85. Which of the following statements in a Boolean algebra is correct?
- (A)  $\overline{AB} = \overline{A} + B$   
 (B)  $\overline{AB} = \overline{A} \cdot \overline{B}$   
 (C)  $\overline{AB} = A + \overline{B}$   
 (D)  $\overline{AB} = \overline{A} + \overline{B}$
86. The sequence that is in ascending order in size is
- (A) bit, word, byte, nibble  
 (B) nibble, byte, bit, word  
 (C) nibble, bit, word, byte  
 (D) bit, nibble, byte, word



87. INDIA became Sovereign Democratic Republic country on

- (A) 1950, January 26
- (B) 1948, January 26
- (C) 1947, August 15
- (D) 1952, January 26

88. In the following table, numbers 1, 2, 3, 4 are to be arranged wherever missing in such a way that each row as well as each column has all of these numbers exactly once

|   |   |   |   |
|---|---|---|---|
|   |   | 4 | 2 |
| 2 | 4 |   |   |
|   |   |   | 1 |
|   | 1 |   |   |

The missing entries in the main diagonal are

- (A) 1, 2, 3
  - (B) 2, 3, 4
  - (C) 1, 3, 4
  - (D) 1, 2, 4
89. If the word MANMOHANWASHERE corresponds to ZOAABVNBIOFVRFR, then the word that corresponds to LRF is
- (A) HEY
  - (B) MAN
  - (C) GOT
  - (D) YES

90. The next term in the sequence  $1, \frac{3}{2}, \frac{11}{6}, \frac{25}{12}, \frac{137}{60}, \dots$  is

- (A)  $\frac{7}{10}$
- (B)  $\frac{299}{120}$
- (C)  $\frac{151}{60}$
- (D)  $\frac{49}{20}$

91. The Headquarter of UNO is based in the city

- (A) Geneva
- (B) London
- (C) Moscow
- (D) New York



92. Given list I and list II as

| List I                   | List II             |
|--------------------------|---------------------|
| P. Abhijnana Shakuntalam | 1. Tulsidas         |
| Q. Godan                 | 2. Valmiki          |
| R. Ramcharitmanas        | 3. Kalidas          |
| S. Ramayana              | 4. Jawaharlal Nehru |
| T. Discovery of India    | 5. Prem Chand       |

Which of the following group is correct ?

- (A) (R-2, S-3, T-4)  
(B) (P-1, Q-5, S-2)  
(C) (P-3, S-2, T-4)  
(D) (Q-5, R-2, T-4)
93. In 2004 Olympic Games, Rajyavardhan Singh Rathore won
- (A) Gold Medal  
(B) Silver Medal  
(C) Bronze Medal  
(D) No Medal
94. A man has to travel from a point P to a point Q, 256 km apart. He travels half the distance on day one, half of the remaining distance on day two, half of the remaining distance on day three and so on. He reaches exactly at the point Q
- (A) in 8 days  
(B) in 16 days  
(C) in 24 days  
(D) never
95. A pipe can fill an empty tank in 6 hours, while another pipe can empty the full tank in 8 hours. If both the pipes are opened together when the tank is half full, then the tank will be full in
- (A) 6 hours  
(B) 12 hours  
(C) 18 hours  
(D) 20 hours
96. Total number of ways in which four boys and three girls can sit in a row so that boys and girls have alternate seats is
- (A) 72  
(B) 144  
(C) 288  
(D) 720



97. Consider the following statements  
*Ram eats if he is hungry*  
*If Ram eats, then he will sleep*  
which of the following is true ?  
(A) Ram is sleeping, he ate  
(B) Ram did not eat, he is not sleeping  
(C) Ram ate, he is not hungry  
(D) Ram is not sleeping, he did not eat
98. Let there be six distinct points in a plane. The maximum number of polygons having these points as their only vertices is  
(A) 24  
(B) 42  
(C) 64  
(D) 84
99. In the context of Internet, WWW stands for  
(A) Wireless World Web  
(B) World Wise Web  
(C) Wide Wireless Web  
(D) World Wide Web
100. Match list I and list II and select the correct answer
- | List I             | List II      |
|--------------------|--------------|
| P. Azim Premji     | 1. Microsoft |
| Q. Narayana Murthy | 2. Wipro     |
| R. Bill Gates      | 3. Satyam    |
| S. Ramalinga Raju  | 4. Infosys   |
- (A) (P, 1), (Q, 2), (R, 3), (S, 4)  
(B) (P, 2), (Q, 3), (R, 4), (S, 1)  
(C) (P, 3), (Q, 1), (R, 2), (S, 4)  
(D) (P, 2), (Q, 4), (R, 1), (S, 3)