

# GATE - 2004

## CE : Civil Engineering

Duration : Three Hours

Maximum Marks : 150

### Q. 1-30 Carry One Marks Each

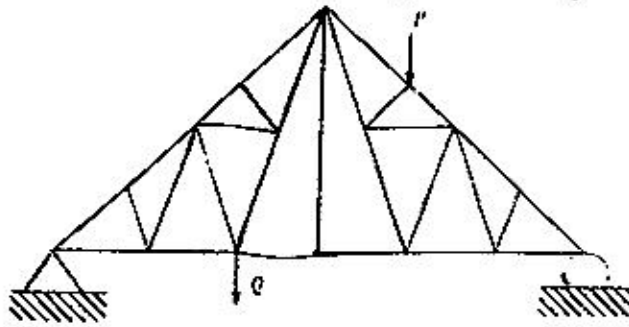
1. Real matrices  $[A]_{3 \times 1}$ ,  $[B]_{3 \times 3}$ ,  $[C]_{3 \times 5}$ ,  $[D]_{5 \times 3}$ ,  $[E]_{5 \times 5}$ , and  $[F]_{5 \times 1}$  are given. Matrices  $[B]$  and  $[E]$  are symmetric. Following statements are made with respect to these matrices.  
(I) Matrix product  $[F]^T [C]^T [B] [C] [F]$  is a scalar  
(II) Matrix product  $[D]^T [F] [D]$  is always symmetric  
With reference to above statements, which of the following applies?  
(a) Statement I is true but II is false  
(b) Statement I is false but II is true  
(c) Both the statements are true  
(d) Both the statements are false
2. The summation of series  $S = 2 + \frac{5}{2} + \frac{8}{2^2} + \frac{11}{2^3} + \dots \infty$  is  
(a) 4.50 (b) 6.0  
(c) 6.75 (d) 10.0
3. The value of the function  $f(x) = \lim_{x \rightarrow 0} \frac{x^3 + x^2}{2x^3 - 7x^2}$  is  
(a) 0 (b)  $-\frac{1}{7}$   
(c)  $\frac{1}{7}$  (d)  $\infty$
4. For the plane truss shown in the figure, the number of zero force members for the given loading is  
  
(a) 4 (b) 8  
(c) 11 (d) 13
5. The unit load method used in structural analysis is  
(a) applicable only to statically indeterminate structures  
(b) another name for stiffness method  
(c) an extension of Maxwell's reciprocal theorem  
(d) derived from Castigliano's theorem
6. For linear elastic systems, the type of displacement function for the strain energy is  
(a) linear (b) quadratic  
(c) cubic (d) quartic
7. For a linear elastic structural system, minimization of potential energy yields  
(a) compatibility conditions  
(b) constitutive relations  
(c) equilibrium equations  
(d) strain-displacement relations
8. In the limit state design method of concrete structures, the recommended partial material safety factor ( $\gamma_m$ ) for steel according to IS: 456-2000 is  
(a) 1.5 (b) 1.15  
(c) 1.00 (d) 0.87
9. For avoiding the limit state of collapse, the safety of R.C. structures is checked for appropriate combinations of dead load (DL), imposed load or live load (IL), wind load (WL) and earthquake load (EL). Which of the following load combinations is NOT considered?  
(a) 0.9 DL + 1.5 WL  
(b) 1.5 DL + 1.5 WL  
(c) 1.5 DL + 1.5 WL + 1.5 EL  
(d) 1.2 DL + 1.2 IL + 1.2 WL
10. Rivet value is defined as  
(a) lesser of the bearing strength of rivet and the shearing strength of the rivet  
(b) lesser of the bearing strength of rivet and the tearing strength of thinner plate  
(c) greater of the bearing strength of rivet and the shearing strength of the rivet  
(d) lesser of the shearing strength of the rivet and the tearing strength of thinner plate
11. In a plate girder, the web plate is connected to the flange plates by fillet welding. The size of the fillet welds is designed to safely resist  
(a) the bending stresses in the flanges  
(b) the vertical shear force at the section  
(c) the horizontal shear force between the flanges and the web plate  
(d) the forces causing buckling in the web



12. The ratio of saturated unit weight to dry unit weight of a soil is 1.25. If the specific gravity of solids ( $G_s$ ) is 2.56, the void ratio of the soil is  
 (a) 0.625 (b) 0.663  
 (c) 0.944 (d) 1.325
13. A 10 m thick clay layer is underlain by a sand layer of 20 m depth (see figure below). The water table is 5 m below the surface of clay layer. The soil above the water table is capillary saturated. The value of  $\gamma_{sat}$  is  $19 \text{ kN/m}^3$ . The unit weight of water is  $\gamma_w$ . If now the water table rises to the surface, the effective stress at a point P on the interface will

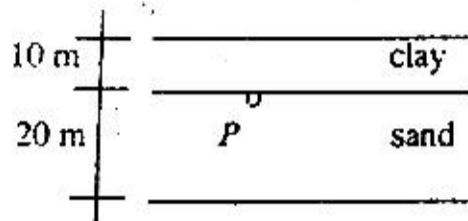

- (a) increase by  $5 \gamma_w$  (b) remain unchanged  
 (c) decrease by  $5 \gamma_w$  (d) decrease by  $10 \gamma_w$
14. In an undrained triaxial test on a saturated clay, the Poisson's ratio is  
 (a)  $\frac{\sigma_3}{(\sigma_1 + \sigma_3)}$  (b)  $\frac{\sigma_3}{(\sigma_1 - \sigma_3)}$   
 (c)  $\frac{(\sigma_1 - \sigma_3)}{\sigma_3}$  (d)  $\frac{(\sigma_1 + \sigma_3)}{\sigma_3}$
15. Two circular footings of diameters  $D_1$  and  $D_2$  are resting on the surface of the same purely cohesive soil. The ratio of their gross ultimate bearing capacities is  
 (a)  $D_1/D_2$  (b) 1.0  
 (c)  $D_1^2/D_2^2$  (d)  $D_2/D_1$
16. An unit volume of a mass of saturated soil is subjected to horizontal seepage. The saturated unit weight is  $22 \text{ kN/m}^3$  and the hydraulic gradient is 0.3. The resultant body force on the soil mass is  
 (a) 1.98 kN (b) 6.6 kN  
 (c) 11.49 kN (d) 22.97 kN
17. The undrained cohesion of a remoulded clay soil is  $10 \text{ kN/m}^2$ . If the sensitivity of the clay is 20, the corresponding remoulded compressive strength is  
 (a)  $5 \text{ kN/m}^2$  (b)  $10 \text{ kN/m}^2$   
 (c)  $20 \text{ kN/m}^2$  (d)  $200 \text{ kN/m}^2$
18. In the inclined manometer shown in the figure below, the reservoir is large. Its surface may be assumed to remain at a fixed elevation. A is connected to a gas pipeline and the deflection noted on the inclined glass tube is 100 mm. Assuming  $\theta = 30^\circ$  and the manometric fluid as oil with specific gravity of 0.86, the pressure at A is

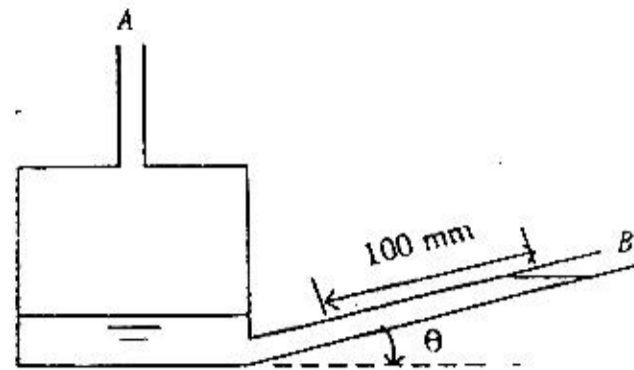

- (a) 43 mm water (vacuum)  
 (b) 43 mm water  
 (c) 86 mm water  
 (d) 100 mm water
19. The x component of velocity in a two dimensional incompressible flow is given by  $u = 1.5x$ . At the point  $(x, y) = (1, 0)$ , the y component of velocity  $v = 0$ . The equation for the y component of velocity is  
 (a)  $v = 0$  (b)  $v = 1.5y$   
 (c)  $v = -1.5x$  (d)  $v = -1.5y$
20. An aircraft is flying in level flight at a speed of  $200 \text{ km/hr}$  through air (density,  $\rho = 1.2 \text{ kg/m}^3$ , and viscosity  $\mu = 1.6 \times 10^{-5} \text{ N-s/m}^2$ ). The lift co-efficient at this speed is 0.4 and the drag co-efficient is 0.0065. The mass of the aircraft is 800 kg. The effective lift area of the aircraft is  
 (a)  $21.2 \text{ m}^2$  (b)  $10.6 \text{ m}^2$   
 (c)  $2.2 \text{ m}^2$  (d)  $1.1 \text{ m}^2$
21. A frictionless fluid of density  $\rho$  flow through a bent pipe as shown below. If A is the cross sectional area and V is the velocity of flow, the forces exerted on segment 1 - 2 of the pipe in the x and y directions are, respectively



- (a)  $\rho AV^2; 0$  (b)  $\rho AV^2; \sqrt{2} \rho AV^2$   
 (c)  $0; 0$  (d)  $0; \frac{1}{\sqrt{2}} \rho AV^2$



22. For a pipe of radius,  $r$ , flowing half full under the action of gravity, the hydraulic depth is
- (a)  $r$  (b)  $\frac{\pi r}{4}$   
(c)  $\frac{r}{2}$  (d)  $0.379 r$
23. A wide channel is 1 m deep and has a velocity of flow,  $V$ , as 2.13 m/s. If a disturbance is caused, an elementary wave can travel upstream with a velocity of
- (a) 1.00 m/s (b) 2.13 m/s  
(c) 3.13 m/s (d) 5.26 m/s
24. A sprinkler irrigation system is suitable when
- (a) the land gradient is steep and the soil is easily erodible  
(b) the soil is having low permeability  
(c) the water table is low  
(d) the crops to be grown have deep roots
25. Most of the turbidity meters work on the scattering principle. The turbidity value so obtained is expressed in
- (a) CFU (b) FTU  
(c) JTU (d) NTU
26. Hardness of water is directly measured by titration with ethylene-di-amine-tetracetic acid(EDTA) using
- (a) eriochrome black T indicator  
(b) ferroin indicator  
(c) methyl orange indicator  
(d) phenolphthalein indicator
27. The organism, which exhibits very nearly the characteristics of an ideal pathogenic indicator is
- (a) Entamoeba histolytica  
(b) Escherichia coli  
(c) Salmonella typhi  
(d) Vibrio comma
28. The Star and Grid pattern of road network was adopted in
- (a) Nagpur Road Plan  
(b) Lucknow Road Plan  
(c) Bombay Road Plan  
(d) Delhi Road Plan
29. The road geometrics in India are designed for the
- (a) 98<sup>th</sup> highest hourly traffic volume  
(b) 85<sup>th</sup> highest hourly traffic volume  
(c) 50<sup>th</sup> highest hourly traffic volume  
(d) 30<sup>th</sup> highest hourly traffic volume

30. In the context of flexible pavement design, the ratio of contact pressure to tyre pressure is called the Rigidity Factor. This factor is less than unity when the tyre pressure is
- (a) less than 0.56 N/mm<sup>2</sup>  
(b) equal to 0.56 N/mm<sup>2</sup>  
(c) equal to 0.7 N/mm<sup>2</sup>  
(d) more than 0.7 M/mm<sup>2</sup>

**Q. 31-90 Carry Two Marks Each**

31. The eigenvalues of the matrix  $\begin{bmatrix} 4 & -2 \\ -2 & 1 \end{bmatrix}$
- (a) are 1 and 4 (b) are -1 and 2  
(c) are 0 and 5 (d) cannot be determined
32. The function  $f(x) = 2x^2 - 3x^2 - 36x + 2$  has its maxima at
- (a)  $x = -2$  only (b)  $x = 0$  only  
(c)  $x = 3$  only (d) both  $x = -2$  and  $x = 3$
33. Biotransformation of an organic compound having concentration ( $x$ ) can be modeled using an ordinary differential equation  $\frac{dx}{dt} + kx^2 = 0$ , where  $k$  is the reaction rate constant. If  $x = a$  at  $t = 0$ , the solution of the equation is
- (a)  $x = ae^{-kt}$  (b)  $\frac{1}{x} = \frac{1}{a} + kt$   
(c)  $x = a(1 - e^{-kt})$  (d)  $x = a + kt$
34. A hydraulic structure has four gates which operate independently. The probability of failure of each gate is 0.2. Given that gate 1 has failed, the probability that both gates 2 and 3 will fail is
- (a) 0.240 (b) 0.200  
(c) 0.040 (d) 0.008
35. For the plane frame with an overhang as shown below, assuming negligible axial deformation, the degree of static indeterminacy,  $d$ , and the degree of kinematic indeterminacy,  $k$ , are

- (a)  $d = 3$  and  $k = 10$   
(b)  $d = 3$  and  $k = 13$   
(c)  $d = 9$  and  $k = 10$   
(d)  $d = 9$  and  $k = 13$

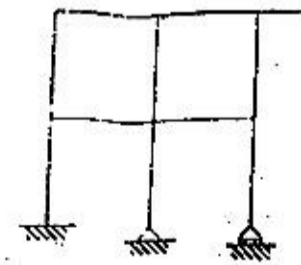

36. A homogeneous, simply supported prismatic beam of width  $B$ , depth  $D$  and span  $L$  is subjected to a concentrated load of magnitude  $P$ . The load can be placed anywhere along the span of the beam. The maximum flexural stress developed in beam is

- (a)  $\frac{2}{3} \frac{PL}{BD^2}$                       (b)  $\frac{3}{4} \frac{PL}{BD^2}$   
 (c)  $\frac{4}{3} \frac{PL}{BD^2}$                       (d)  $\frac{3}{2} \frac{PL}{BD^2}$

37. For the linear elastic beam shown in the figure, the flexural rigidity,  $EI$ , is  $781250 \text{ kN-m}^2$ . When  $w = 10 \text{ kN/m}$ , the vertical reaction  $R_A$  at  $A$  is  $50 \text{ kN}$ . The value of  $R_A$  for  $w = 100 \text{ kN/m}$  is

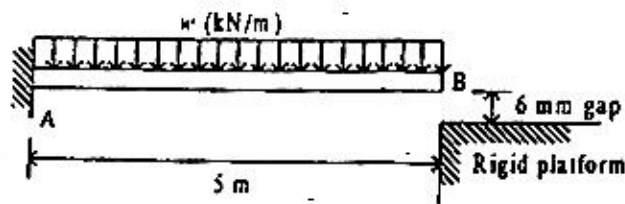

- (a)  $500 \text{ kN}$                       (b)  $425 \text{ kN}$   
 (c)  $250 \text{ kN}$                       (d)  $75 \text{ kN}$

38. In a two dimensional stress analysis, the state of stress at a point is shown below. If  $s = 120 \text{ MPa}$  and  $t = 70 \text{ MPa}$ , then  $s_x$  and  $s_y$  are respectively

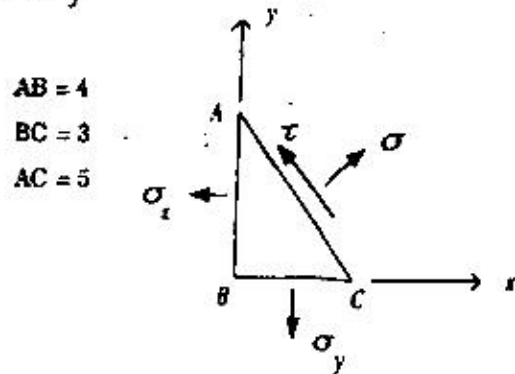

- (a)  $26.7 \text{ MPa}$  and  $172.5 \text{ MPa}$   
 (b)  $54 \text{ MPa}$  and  $128 \text{ MPa}$   
 (c)  $67.5 \text{ MPa}$  and  $213.3 \text{ MPa}$   
 (d)  $16 \text{ MPa}$  and  $138 \text{ MPa}$

39. A circular solid shaft of span  $L = 5 \text{ m}$  is fixed at one end and free at the other end. A twisting moment  $T = 100 \text{ kN-m}$  is applied at the free end. The torsional rigidity  $GJ$  is  $50000 \text{ kN-m}^2/\text{rad}$ .

Following statements are made for this shaft.

- (I) The maximum rotation is  $0.01 \text{ rad}$   
 (II) The torsional strain energy is  $1 \text{ kN-m}$

With reference to the above statements, which of the following applies?

- (a) Both statements are true  
 (b) Statement I is true but II is false  
 (c) Statement II is true but I is false  
 (d) Both the statements are false

40. A three-hinged parabolic arch  $ABC$  has a span of  $20 \text{ m}$  and a central rise of  $4 \text{ m}$ . The arch has hinges at the ends at the centre. A train of two point loads of  $20 \text{ kN}$  and  $10 \text{ kN}$ ,  $5 \text{ m}$  apart, crosses this arch from left to right, with  $20 \text{ kN}$  load leading. The maximum thrust induced at the supports is

- (a)  $25.00 \text{ kN}$                       (b)  $28.13 \text{ kN}$   
 (c)  $31.25 \text{ kN}$                       (d)  $32.81 \text{ kN}$

41. The plane frame below is analyzed by neglecting axial deformations. Following statements are made with respect to the analysis

- (I) Column  $AB$  carries axial force only  
 (II) Vertical deflection at the center of beam  $BC$  is  $1 \text{ mm}$

With reference to the above statements, which of the following applies?

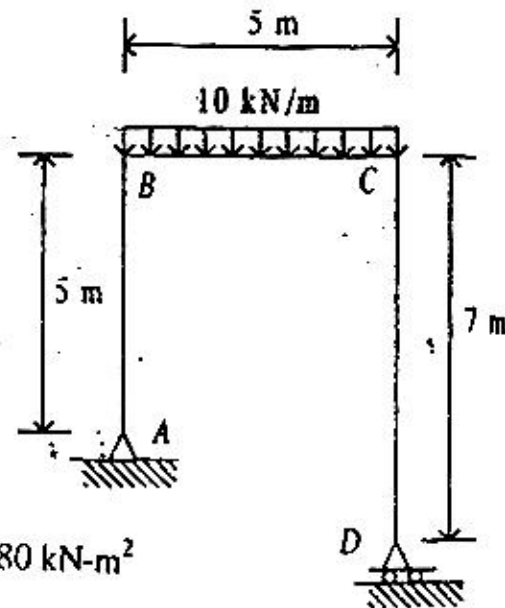

$EI = 81380 \text{ kN-m}^2$

- (a) Both the statements are true  
 (b) Statement I is true but II is false  
 (c) Statement II is true but I is false  
 (d) Both the statements are false

42. An R.C. short column with  $300 \text{ mm} \times 300 \text{ mm}$  square cross-section is made of M20 grade concrete and has 4 numbers,  $20 \text{ mm}$  diameter longitudinal bars of Fe 415 steel. It is under the action of a concentric axial compressive load. Ignoring the reduction in the area of concrete due to steel bars, the ultimate axial load carrying capacity of the column is

- (a)  $1659 \text{ kN}$                       (b)  $1548 \text{ kN}$   
 (c)  $1198 \text{ kN}$                       (d)  $1069 \text{ kN}$



43. An R.C. square footing of side length 2 m and uniform effective depth 200 mm is provided for a 300 mm X 300 mm column. The line of action of the vertical compressive load passes through the centroid of the footing as well as of the column. If the magnitude of the load is 320 kN, the nominal transverse (one way) shear stress in the footing is  
 (a) 0.26 N/mm<sup>2</sup> (b) 0.30 N/mm<sup>2</sup>  
 (c) 0.34 N/mm<sup>2</sup> (d) 0.75 N/mm<sup>2</sup>
44. A simply supported prestressed concrete beam is 6 m long and 300 mm wide. Its gross depth is 600 mm. It is prestressed by horizontal cable tendons at a uniform eccentricity of 100 mm. The prestressing tensile force in the cable tendons is 1000 kN. Neglect the self weight of beam. The maximum normal compressive stress in the beam at transfer is  
 (a) Zero (b) 5.55 N/mm<sup>2</sup>  
 (c) 11.11 N/mm<sup>2</sup> (d) 15.68 N/mm<sup>2</sup>
45. A moment  $M$  of magnitude 50 kN-m is transmitted to a column flange through a bracket by using four 20 mm diameter rivets as shown in the figure

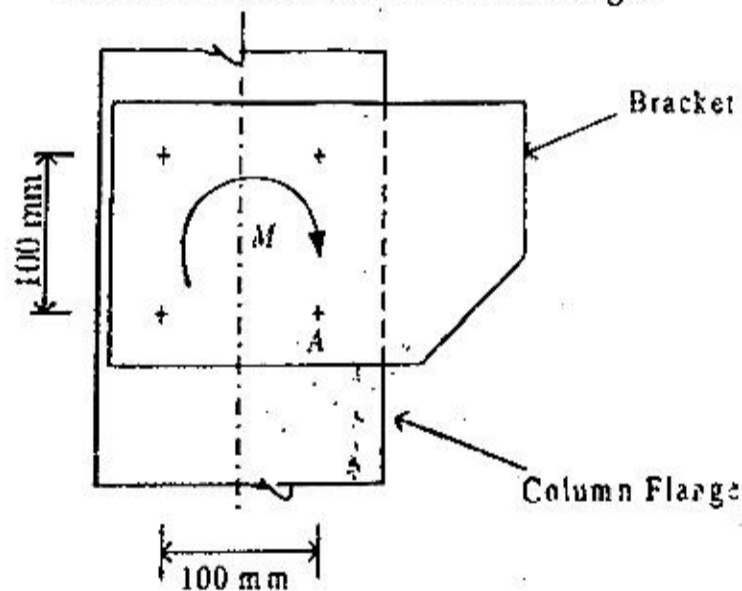

The shear force induced in the rivet A is

- (a) 250 kN (b) 175.8 kN  
 (c) 125 kN (d) 88.4 kN
46. Two equal angles ISA 100 mm x 100 mm of thickness 10 mm are placed back-to-back and connected to the either side of a gusset plate through a single row of 16 mm diameter rivets in double shear. The effective areas of the connected and unconnected legs of each of these angles are 775 mm<sup>2</sup> and 950 mm<sup>2</sup>, respectively. If these angles are NOT tackriveted, the net effective area of this pair of angles is  
 (a) 3650 mm<sup>2</sup> (b) 3450 mm<sup>2</sup>  
 (c) 3076 mm<sup>2</sup> (d) 2899 mm<sup>2</sup>

47. A strut in a steel truss is composed of two equal angles ISA 150 mm x 150 mm of thickness 100 mm connected back-to-back to the same side of a gusset plate. The cross sectional area of each angle is 2921 mm<sup>2</sup> and moment of inertia ( $I_{xx} = I_{yy}$ ) is 6335000 mm<sup>4</sup>. The distance of the centroid of the angle from its surface ( $C_x = C_y$ ) is 40.8 mm. The minimum radius of gyration of the strut is  
 (a) 93.2 mm (b) 62.7 mm  
 (c) 46.6 mm (d) 29.8 mm
48. A square steel slab base of area 1 m<sup>2</sup> is provided for a column made of two rolled channel sections. The 300 mm x 300 mm column carries an axial compressive load of 2000 kN. The line of action of the load passes through the centroid of the column section as well as of the slab base. The permissible bending stress in the slab base is 185 MPa. The required minimum thickness of the slab base is  
 (a) 110 mm (b) 89 mm  
 (c) 63 mm (d) 55 mm
49. A propped cantilever of span  $L$  is carrying a vertical concentrated load acting at midspan. The plastic moment of the section is  $M_p$ . The magnitude of the collapse load is  
 (a)  $\frac{8M_p}{L}$  (b)  $\frac{6M_p}{L}$   
 (c)  $\frac{4M_p}{L}$  (d)  $\frac{2M_p}{L}$
50. The figure given below represents the contact pressure distribution underneath a

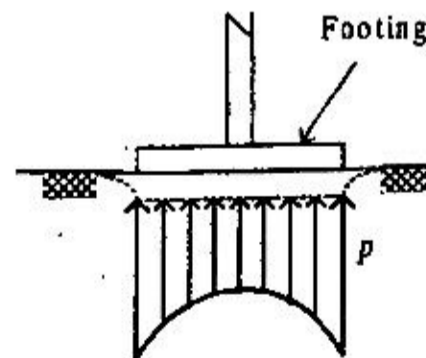

- (a) rigid footing on saturated clay  
 (b) rigid footing on sand  
 (c) flexible footing on saturated clay  
 (d) flexible footing on sand



51. An infinite soil slope with an inclination of  $35^\circ$  is subjected to seepage parallel to its surface. The soil has  $c' = 100 \text{ kN/m}^2$  and  $f' = 30^\circ$ . Using the concept of mobilized cohesion and friction, at a factor of safety of 1.5 with respect to shear strength, the mobilized friction angle is

- (a)  $20.02^\circ$  (b)  $21.05^\circ$   
 (c)  $23.33^\circ$  (d)  $30.00^\circ$

52. A 6m thick clay layer undergoes 90% consolidation four times faster under two-way drainage as compared to one-drainage. In an identical clay layer of 15 m thickness, two-way drainage will be faster as compared to one-way drainage by

- (a) 8 times (b) 4 times  
 (c) 2.5 times (d) 2 times

53. Using  $\phi_u = 0$  analysis and assuming planar failure as shown, the minimum factor of safety against shear failure of a vertical cut of height 4 m in a pure clay having  $c_u = 120 \text{ kN/m}^2$  and  $\gamma_{\text{sat}} = 20 \text{ kN/m}^3$  is

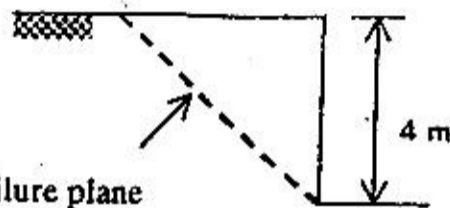

Potential failure plane

- (a) 1 (b) 6  
 (c) 10 (d) 20

54. In the context of collecting undisturbed soil samples of high quality using a spoon sampler, following statements are made.

- (I) Area ratio should be less than 10%.  
 (II) Clearance ratio should be less than 1%.

With reference to above statements, which of the following applies?

- (a) Both the statements are true  
 (b) Statement II is true but I is false  
 (c) Statement I is true but II is false  
 (d) Both the statements are false

55. The figure below shows two flow lines for seepage across an interface between two soil media of different co-efficients of permeability. If entrance angle  $\alpha_1 = 30^\circ$ , the exit angle  $\alpha_2$  will be

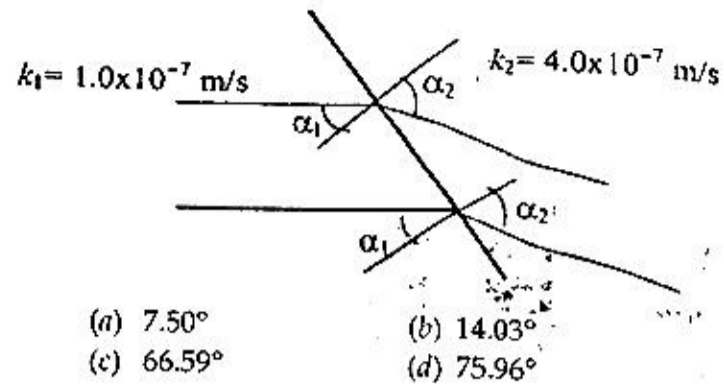

- (a)  $7.50^\circ$  (b)  $14.03^\circ$   
 (c)  $66.59^\circ$  (d)  $75.96^\circ$

56. An unsupported excavation is made to the maximum possible depth in a clay soil having  $\gamma_t = 18 \text{ kN/m}^3$ ,  $c = 100 \text{ kN/m}^2$ ,  $\phi = 30^\circ$ . The active earth pressure, according to Rankine's theory, at the base level of the excavation is

- (a)  $115.47 \text{ kN/m}^2$  (b)  $54.36 \text{ kN/m}^2$   
 (c)  $27.18 \text{ kN/m}^2$  (d)  $13. \text{ kN/m}^2$

57. A retaining wall of height 8 m retains dry sand. In the initial state, the soil is loose and has a void ratio of 0.5,  $\gamma_d = 17.8 \text{ kN/m}^3$  and  $\phi = 30^\circ$ . Subsequently, the backfill is compacted to a state where void ratio is 0.4,  $\gamma_d = 18.8 \text{ kN/m}^3$  and  $\phi = 35^\circ$ . The ratio of initial passive thrust to the final passive thrust, according to Rankine's earth pressure theory, is

- (a) 0.38 (b) 0.64  
 (c) 0.77 (d) 1.55

58. A velocity field is given as  $\vec{V} = 2y\hat{i} + 3x\hat{j}$  where x and y are in metres. The acceleration of the a fluid particle at  $(x, y) = (1, 1)$  in the x direction is

- (a)  $0 \text{ m/s}^2$  (b)  $5.00 \text{ m/s}^2$   
 (c)  $6.00 \text{ m/s}^2$  (d)  $8.48 \text{ m/s}^2$

59. A thin flat plate  $0.5 \text{ m} \times 0.7 \text{ m}$  in size settles in a large tank of water with a terminal velocity of  $0.12 \text{ m/s}$ . The co-efficient of drag  $C_D = \frac{1.328}{\sqrt{R_L}}$  for

a laminar boundary layer and  $C_D = \frac{0.072}{(R_L)^{1/5}}$  for a turbulent boundary layer, where  $R_L$  is the plate Reynolds number.

Assume  $\mu = 10^{-3} \text{ N-s/m}^2$  and  $\rho = 1000 \text{ kg/m}^3$

The submerged weight of the plate is

- (a) 0.0115 N  
 (b) 0.0118 N  
 (c) 0.0231 N  
 (d) 0.0376 N

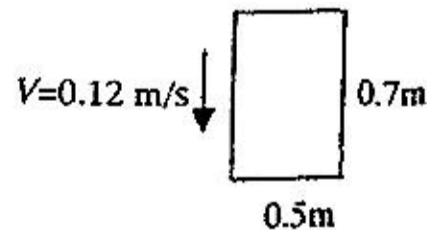

60. A fire protection system is supplied from a water tower with a bent pipe as shown in the figure. The pipe friction  $f$  is 0.03. Ignoring all minor losses, the maximum discharge,  $Q$ , in the pipe is

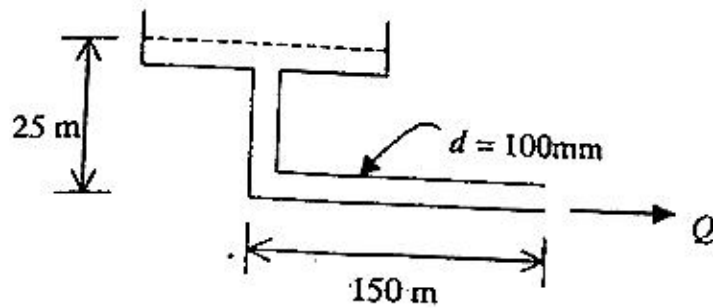

- (a) 31.7 lit/sec      (b) 24.0 lit/sec  
(c) 15.9 lit/sec      (d) 12.0 lit/sec
61. A steady flow occurs in an open channel with lateral inflow of  $q \text{ m}^3/\text{s}$  per unit width as shown in the figure. The mass conservation equation is

(a)  $\frac{\partial q}{\partial x} = 0$

(b)  $\frac{\partial Q}{\partial x} = 0$

(c)  $\frac{\partial Q}{\partial x} - q = 0$

(d)  $\frac{\partial Q}{\partial x} + q = 0$

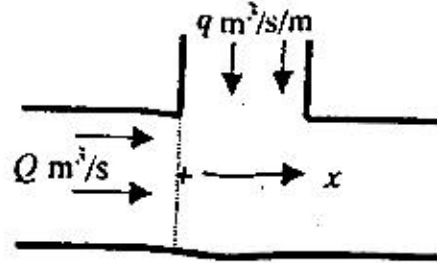

62. A steep wide rectangular channel takes off from a reservoir having an elevation of 101.2 m. At the entrance, the bottom elevation of the channel is 100 m. If the slope of the channel is increased by 4%, the discharge per unit length in the channel will be
- (a) 2.24  $\text{m}^2/\text{s}$   
(b) higher than 2.24  $\text{m}^2/\text{s}$  by 4%  
(c) higher than 2.24  $\text{m}^2/\text{s}$  by 2%  
(d) choked

63. The velocity in  $\text{m}/\text{s}$  at a point in a two-dimensional flow is given as  $\vec{V} = 2\hat{i} + 3\hat{j}$ . The equation of the stream line passing through the point is
- (a)  $3dx - 2dy = 0$       (b)  $2x + 3y = 0$   
(c)  $3dx + 2dy = 0$       (d)  $xy = 6$

64. The allowable net positive suction head (NPSH) for a pump provided by the manufacturer for a flow of  $0.05 \text{ m}^3/\text{s}$  is 3.3 m. The temperature of water is  $30^\circ \text{C}$  (vapour pressure head absolute = 0.44 m),

atmospheric pressure is 100 kPa absolute and the head loss from the reservoir to pump is  $0.3 \text{ N}\cdot\text{m}/\text{N}$ . The maximum height of the pump above the suction reservoir is

- (a) 10.19 m      (b) 6.89 m  
(c) 6.15 m      (d) 2.86 m

65. The rainfall during three successive 2 hour periods are 0.5, 2.8 and 1.6 cm. The surface runoff resulting from this storm is 3.2 cm. The  $\phi$  index value of this storm is

- (a) 0.20 cm/hr  
(b) 0.28 cm/hr  
(c) 0.30 cm/hr  
(d) 0.80 cm/hr

66. The average rainfall for a 3 hour duration storm is 2.7 cm and the loss rate is 0.3 cm/hr. The flood hydrograph has a base flow of  $20 \text{ m}^3/\text{s}$  and produces a peak flow of  $210 \text{ m}^3/\text{s}$ . The peak of a 3-h unit hydrograph is

- (a)  $125.50 \text{ m}^3/\text{s}$       (b)  $105.50 \text{ m}^3/\text{s}$   
(c)  $77.77 \text{ m}^3/\text{s}$       (d)  $70.37 \text{ m}^3/\text{s}$

67. A canal irrigates a portion of a culturable command area to grow sugarcane and wheat. The average discharges required to grow sugarcane and wheat are, respectively, 0.36 and 0.27 cumecs. The time factor is 0.9. The required design capacity of the canal is

- (a) 0.36 cumecs      (b) 0.40 cumecs  
(c) 0.63 cumecs      (d) 0.70 cumecs

68. The height of a hydraulic jump in the stilling pool of 1.25 scale model was observed to be 10 cm. The corresponding prototype height of the jump is

- (a) not determinable from the data given  
(b) 2.5 m  
(c) 0.5 m  
(d) 0.1 m

69. The present population of a community is 28000 with an average water consumption of  $4200 \text{ m}^3/\text{d}$ . The existing water treatment plant has a design capacity of  $6000 \text{ m}^3/\text{d}$ . It is expected that the population will increase to 44000 during the next 20 years. The number of years from now when the plant will reach its design capacity, assuming an arithmetic rate of population growth, will be

- (a) 5.5 years  
(b) 8.6 years  
(c) 15.0 years  
(d) 16.5 years



70. An existing 300 mm diameter circular sewer is laid at a slope of 1:28 and carries a peak discharge of  $1728 \text{ m}^3/\text{d}$ . Use the partial flow diagram shown in the figure below and assume Manning's  $n = 0.015$ .

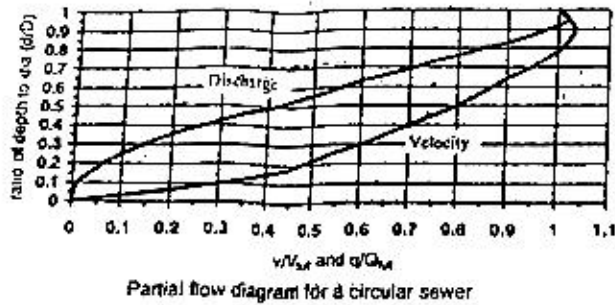

Partial flow diagram for a circular sewer

At the peak discharge, the depth of flow and the velocity are, respectively

- (a) 45 mm and 0.28 m/s  
 (b) 120 mm and 0.50 m/s  
 (c) 150 mm and 0.57 m/s  
 (d) 300 mm and 0.71 m/s
71. An analysis for determination of solids in the return sludge of activated sludge process was done as follows: (1) A crucible was dried to a constant mass of 62.485 g. (2) 75 ml of a well-mixed sample was taken in the crucible. (3) The crucible with the sample was dried to a constant mass of 65.020 g in a drying oven at  $104^\circ \text{C}$ . (4) The crucible with the dried sample was placed in a muffle furnace at  $600^\circ \text{C}$  for an hour. After cooling, the mass of the crucible with residues was 63.145 g. The concentration of organic fraction of solids present in the return sludge sample is
- (a) 8800 mg/l                      (b) 25000 mg/l  
 (c) 33800 mg/l                    (d) 42600 mg/l
72. Water samples (X and Y) from two different sources were brought to the laboratory for the measurement of dissolved oxygen (DO) using modified Winkler method. Samples were transferred to 300 ml BOD bottles. 2 ml of  $\text{MnSO}_4$  solution and 2 ml of alkaliodide-azide reagent were added to the bottles and mixed. Sample X developed a brown precipitate, whereas sample Y developed a white precipitate. In reference to these observations, the correct statement is
- (a) Both the samples were devoid of DO  
 (b) Sample X was devoid of DO while sample Y contained DO  
 (c) Sample X contained DO while sample Y was devoid of DO  
 (d) Both the samples contained DO

73. A portion of wastewater sample was subjected to standard BOD test (5 days,  $20^\circ \text{C}$ ), yielding a value of 180 mg/l. The reaction rate constant (to the base 'e') at  $20^\circ \text{C}$  was taken as 0.18 per day. The reaction rate constant at other temperature may be estimated by  $k_T = k_{20} (1.047)^{T-20}$ . The temperature at which the other portion of the sample should be tested, to exert the same BOD in 2.5 days, is
- (a)  $4.9^\circ \text{C}$                               (b)  $24.9^\circ \text{C}$   
 (c)  $31.7^\circ \text{C}$                              (d)  $35.0^\circ \text{C}$

74. A standard multiple-tube fermentation test was conducted on a sample of water from a surface stream. The results of the analysis for the confirmed test are given below.

Sample Size (ml)	No. of positive results out of 5 tubes	No. of negative results out of 5 tubes
1.0	4	1
0.1	3	2
0.01	1	4

MPN Index and 95% confidence limits for combination of positive results when five tubes used per dilutions (10 ml, 1.0 ml, 0.1 ml)

Combination of positives	MPN Index per 100 ml	95% confidence limit	
		Lower	Upper
4-2-1	26	12	65
4-3-1	33	15	77

Using the above MPN Index table, the most probable number (MPN) of the sample is

- (a) 26                                      (b) 33  
 (c) 260                                    (d) 330
75. The following data are given for a channel-type grit chamber of length 7.5 m.
- flow-through velocity = 0.3 m/s
  - the depth of wastewater at peak flow in the channel = 0.9 m
  - specific gravity of inorganic particles = 2.5
  - $g = 9.80 \text{ m/s}^2$ ,  $\mu = 1.002 \times 10^{-3} \text{ N-s/m}^2$  at  $20^\circ \text{C}$ ,  $\rho_w = 1000 \text{ kg/m}^3$
- Assuming that the Stokes law is valid, the largest diameter particle that would be removed with 100 percent efficiency is
- (a) 0.04 mm                              (b) 0.21 mm  
 (c) 1.92 mm                              (d) 6.64 mm





76. The design parameter for flocculation is given by a dimensionless number  $Gt$ , where  $G$  is the velocity gradient and  $t$  is the detention time. Values of  $Gt$  ranging from  $10^4$  to  $10^5$  are commonly used, with  $t$  ranging from 10 to 30 min. The most preferred combination of  $G$  and  $t$  to produce smaller and denser flocs is

- (a) large  $G$  values with short  $t$
- (b) large  $G$  values with long  $t$
- (c) small  $G$  values with short  $t$
- (d) small  $G$  values with long  $t$

77. Chlorine gas used for disinfection combines with water to form hypochlorous acid ( $\text{HOCl}$ ). The  $\text{HOCl}$  ionizes to form hypochlorite ( $\text{OCl}^-$ ) in a reversible reaction:

$\text{HOCl} \rightleftharpoons \text{H}^+ + \text{OCl}^-$  ( $k = 2.7 \times 10^{-8}$  at  $20^\circ \text{C}$ ),  
the equilibrium of which is governed by pH. The sum of  $\text{HOCl}$  and  $\text{OCl}^-$  is known as free chlorine residual and  $\text{HOCl}$  is the more effective disinfectant. The 90% fraction of  $\text{HOCl}$  in the free chlorine residual is available at a pH value

- (a) 4.8
- (b) 6.6
- (c) 7.5
- (d) 9.4

78. For a road with camber of 3% and the design speed of 80 km/hr, the minimum radius of the curve, beyond which NO superelevation is needed, is

- (a) 1680 m
- (b) 948 m
- (c) 406 m
- (d) 280 m

79. Three new roads P, Q, and R are planned in a district. The data for these roads are given in the table below.

Road	Length (km)	Number of villages with population		
		Less than 200	2000 - 5000	More than 5000
P	20	8	6	1
Q	28	19	8	4
R	12	7	5	2

Based on the principle of maximum utility, the order of priority for these three roads should be

- (a) P, Q, R
- (b) Q, R, P
- (c) R, P, Q
- (d) R, Q, P

80. A Marshall specimen is prepared for bituminous concrete with a bitumen content of 5 percent by weight of total mix. The theoretical and the measured unit weights of the mix are  $2.442 \text{ g/cm}^3$  and  $2.345 \text{ g/cm}^3$ , respectively. The bitumen has a specific gravity of 1.02. The percent voids in mineral aggregate filled with bitumen (VFB) are

- (a) 34.55
- (b) 35.9
- (c) 73.55
- (d) 74.3

81. The data given below pertain to the design of a flexible pavement.

Initial traffic = 1213 cvpd

Traffic growth rate = 8 percent per annum

Design life = 12 years

Vehicle damage factor = 2.5

Distribution factor = 1.0

The design traffic in terms of million standard axles (msa) to be catered would be

- (a) 0.06 msa
- (b) 8.40 msa
- (c) 21.00 msa
- (d) 32.26 msa

82. The co-efficient of friction in the longitudinal direction of a highway is estimated as 0.396. The braking distance for a car moving at a speed of 65 km/hr is

- (a) 87 m
- (b) 45 m
- (c) 42 m
- (d) 40 m

Data for Q. 83-84 are given below. Solve the problems and choose the correct answers.

A three-span continuous beam has an internal hinge at B. Section B is at the mid-span of AC. Section E is at the mid-span of CG. The 20 kN load is applied at section B whereas 10 kN loads are applied at sections D and F as shown in the figure. Span GH is subjected to uniformly distributed load of magnitude 5 kN/m. For the loading shown, shear force immediate to the right of section E is 9.84 kN upwards and the sagging moment at section E is 10.31 kN-m.

$AB = BC = 2 \text{ m}$   
 $CD = DE = EF = FG = 1 \text{ m}$   
 $GH = 4 \text{ m}$

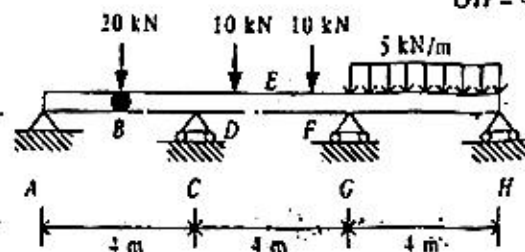

83. The magnitude of the shear force immediate to the left and immediate to the right of section B are, respectively

- (a) 0 and 20 kN
- (b) 10 kN and 10 kN
- (c) 20 kN and 0
- (d) 9.84 kN and 10.16 kN

84. The vertical reaction at support H is

- (a) 15 kN upward
- (b) 9.84 kN upward
- (c) 15 kN downward
- (d) 9.84 kN downward

Data for Q. 85-86 are given below. Solve the problems and choose the correct answers.

At the limit state of collapse, an R.C. beam is subjected to flexural moment 200 kN-m, shear force 20 kN and torque 9 kN-m. The beam is 300 mm wide and has a gross depth of 425 mm, with an effective cover of



25 mm. The equivalent nominal shear stress ( $\tau_{ve}$ ) as calculated by using the design code turns out to be lesser than the design shear strength ( $\tau_c$ ) of the concrete.

85. The equivalent shear force ( $V_c$ ) is  
 (a) 20 kN (b) 54 kN  
 (c) 56 kN (d) 68 kN
86. The equivalent flexural moment ( $M_{eq}$ ) for designing the longitudinal tension steel is  
 (a) 187 kN-m (b) 200 kN-m  
 (c) 209 kN-m (d) 213 kN-m

Data for Q. 87-88 are given below. Solve the problems and choose the correct answers.

A group of 16 piles of 10 m length and 0.5 m diameter is installed in a 10 m thick stiff clay layer underlain by rock. The pile-soil adhesion factor is 0.4; average shear strength of soil on the sides on the sides is 100 kPa; undrained shear strength of the soil at the base is also 100 kPa.

87. The base resistance of a single pile is  
 (a) 40.00 kN (b) 88.35 kN  
 (c) 100.00 kN (d) 176.71 kN
88. Assuming 100% efficiency, the group side resistance is  
 (a) 5026.5 kN (b) 10000.0 kN  
 (c) 10053.1 kN (d) 20106.0 kN

Data for Q. 89-90 are given below. Solve the problems and choose the correct answers.

The laminar flow takes place between closely spaced parallel plates as shown in figure below. The velocity

profile is given by  $u = V \frac{y}{h}$ . The gap height,  $h$ , is 5 mm and the space is filled with oil (specific gravity = 0.86, viscosity  $\mu = 2 \times 10^{-4}$  N-s/m<sup>2</sup>). The bottom plate is stationary and the top plate moves with a steady velocity of  $V = 5$  cm/s. The area of the plate is 0.25 m<sup>2</sup>.

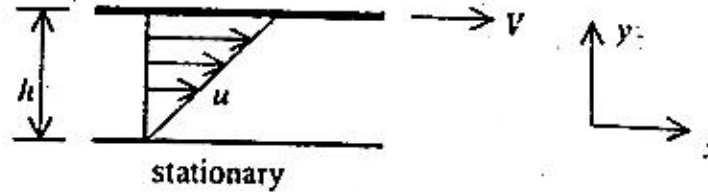

89. The rate of rotation of a fluid particle is given by  
 (a)  $\omega_y = 0; \omega_z = -\frac{y}{2h}$  (b)  $\omega_y = 0; \omega_z = -\frac{\dot{y}}{h}$   
 (c)  $\omega_y = \frac{y}{h}; \omega_z = \frac{y}{h}$  (d)  $\omega_y = \frac{y}{h}; \omega_z = 0$
90. The power required to keep the plate in steady motion is  
 (a)  $5 \times 10^{-4}$  watts (b)  $10^{-5}$  watts  
 (c)  $2.5 \times 10^{-5}$  watts (d)  $5 \times 10^{-5}$  watts

## ANSWERS

- |         |         |         |         |         |         |         |         |         |         |
|---------|---------|---------|---------|---------|---------|---------|---------|---------|---------|
| 1. (a)  | 2. (d)  | 3. (b)  | 4. (a)  | 5. (a)  | 6. (a)  | 7. (c)  | 8. (b)  | 9. (c)  | 10. (a) |
| 11. (c) | 12. (b) | 13. (c) | 14. (b) | 15. (b) | 16. (b) | 17. (b) | 18. (b) | 19. (d) | 20. (d) |
| 21. (c) | 22. (b) | 23. (a) | 24. (a) | 25. (c) | 26. (a) | 27. (b) | 28. (a) | 29. (d) | 30. (d) |
| 31. (c) | 32. (a) | 33. (b) | 34. (c) | 35. (d) | 36. (d) | 37. (c) | 38. (a) | 39. (b) | 40. (c) |
| 41. (a) | 42. (d) | 43. (a) | 44. (c) | 45. (b) | 46. (c) | 47. (c) | 48. (d) | 49. (b) | 50. (a) |
| 51. (b) | 52. (b) | 53. (b) | 54. (c) | 55. (c) | 56. (a) | 57. (c) | 58. (d) | 59. (a) | 60. (b) |
| 61. (b) | 62. (c) | 63. (a) | 64. (c) | 65. (c) | 66. (b) | 67. (d) | 68. (b) | 69. (c) | 70. (c) |
| 71. (c) | 72. (c) | 73. (d) | 74. (b) | 75. (b) | 76. (d) | 77. (b) | 78. (d) | 79. (d) | 80. (c) |
| 81. (c) | 82. (c) | 83. (a) | 84. (b) | 85. (d) | 86. (d) | 87. (d) | 88. (c) | 89. (a) | 90. (c) |

