

tscte

Question Paper Name: Instrumentation Engineering 28th May 2019 Shift 1
Subject Name: Instrumentation Engineering
Creation Date: 2019-05-27 18:29:50
Duration: 120
Total Marks: 120
Display Marks: No
Share Answer Key With Delivery Engine: Yes
Actual Answer Key: Yes

Instrumentation Engineering

Group Number : 1
Group Id : 39090032
Group Maximum Duration : 0
Group Minimum Duration : 120
Revisit allowed for view? : No
Revisit allowed for edit? : No
Break time: 0
Group Marks: 120

Mathematics

Section Id : 39090059
Section Number : 1
Section type : Online
Mandatory or Optional: Mandatory
Number of Questions: 10
Number of Questions to be attempted: 10
Section Marks: 10
Display Number Panel: Yes
Group All Questions: No

Sub-Section Number: 1
Sub-Section Id: 39090059
Question Shuffling Allowed : Yes

Question Number : 1 Question Id : 3909003721 Question Type : MCQ Option Shuffling : Yes Display Question Number : Yes
Single Line Question Option : No Option Orientation : Vertical
Correct Marks : 1 Wrong Marks : 0

If X is a continuous random variable with $P(X = x) = \frac{1}{k(1+x^2)}$, $-\infty < x < +\infty$, then

$k =$

Options :

TS PGECET 2019

1. $\frac{1}{3\pi}$

2. 3π

3. $\frac{1}{\pi}$

4. π

Question Number : 2 Question Id : 3909003722 Question Type : MCQ Option Shuffling : Yes Display Question Number : Yes
Single Line Question Option : No Option Orientation : Vertical
Correct Marks : 1 Wrong Marks : 0

$$\oint_{|z|=1} z e^{z-3} dz =$$

Options :

1. 0

2. $2\pi i$

3. $4\pi i$

4. $6\pi i$

Question Number : 3 Question Id : 3909003723 Question Type : MCQ Option Shuffling : Yes Display Question Number : Yes
Single Line Question Option : No Option Orientation : Vertical
Correct Marks : 1 Wrong Marks : 0

Let $f(z) = \frac{\tan^2 z}{z^2(1-z)}$. Then the number poles of $f(z)$ that lie in the interval $[-2,2]$ is

Options :

1. 3

2. 4

3. 5

4. 6

Question Number : 4 Question Id : 3909003724 Question Type : MCQ Option Shuffling : Yes Display Question Number : Yes
Single Line Question Option : No Option Orientation : Vertical
Correct Marks : 1 Wrong Marks : 0

$$\frac{1}{2\pi i} \oint_{|z|=2} \frac{3z^2 + 7}{z^3 + 7z + 1} dz =$$

Options :

1. 1
2. 2
3. 3
4. 4

Question Number : 5 Question Id : 3909003725 Question Type : MCQ Option Shuffling : Yes Display Question Number : Yes
Single Line Question Option : No Option Orientation : Vertical
Correct Marks : 1 Wrong Marks : 0

A particular integral of $y'' + 4y = 2 \cos^2 x$ is

Options :

1. $\frac{x}{4} \sin 2x + \frac{1}{2} \cos^2 x$
2. $\frac{x}{2} \sin 2x + \frac{1}{4} \cos^2 x$
3. $\frac{x}{4} \sin 2x - \frac{1}{2} \cos^2 x$
4. $\frac{x}{2} \sin 2x - \frac{1}{4} \cos^2 x$

Question Number : 6 Question Id : 3909003726 Question Type : MCQ Option Shuffling : Yes Display Question Number : Yes
Single Line Question Option : No Option Orientation : Vertical
Correct Marks : 1 Wrong Marks : 0

If a curve $y = f(x)$ satisfies $f''(x) = 2 - 4f(x)$ with $f(0) = 1, f'(0) = -1$ then $y = k(1 + \cos 2x - \sin 2x)$, where $k =$

Options :

1. 1

2. $\frac{1}{2}$

3. -1

4. $-\frac{1}{2}$

Question Number : 7 Question Id : 3909003727 Question Type : MCQ Option Shuffling : Yes Display Question Number : Yes
Single Line Question Option : No Option Orientation : Vertical
Correct Marks : 1 Wrong Marks : 0

If $A = \begin{bmatrix} 1 & 1 & -1 \\ -1 & 0 & 1 \\ 1 & 1 & -1 \end{bmatrix}$ then $A^{2019} + A =$

Options :

1. 3×3 unit matrix

2. $-A$

3. 3×3 zero matrix

4. A

Question Number : 8 Question Id : 3909003728 Question Type : MCQ Option Shuffling : Yes Display Question Number : Yes
Single Line Question Option : No Option Orientation : Vertical
Correct Marks : 1 Wrong Marks : 0

The rank of the matrix $\begin{bmatrix} 2 & 3 & 0 & -3 \\ 3 & -1 & 0 & 3 \\ 3 & 3 & -2 & -5 \end{bmatrix}$ is

Options :

1. 0

2. 1

3. 2

4. 3

Question Number : 9 Question Id : 3909003729 Question Type : MCQ Option Shuffling : Yes Display Question Number : Yes
Single Line Question Option : No Option Orientation : Vertical
Correct Marks : 1 Wrong Marks : 0

The global minimum of $x^2 + y^2 - 9y + 100$ is

Options :

1. 90
2. 91
3. 100
4. 89

Question Number : 10 Question Id : 3909003730 Question Type : MCQ Option Shuffling : Yes Display Question Number : Yes
Single Line Question Option : No Option Orientation : Vertical
Correct Marks : 1 Wrong Marks : 0

$$\int_0^1 \int_0^x (3 - x - y) dy dx =$$

Options :

1. 1
2. 2
3. 3
4. 4

Instrumentation Engineering

Section Id :	39090060
Section Number :	2
Section type :	Online
Mandatory or Optional:	Mandatory
Number of Questions:	110
Number of Questions to be attempted:	110
Section Marks:	110
Display Number Panel:	Yes
Group All Questions:	No

TS PGECET 2019

Sub-Section Number: 1
Sub-Section Id: 39090060
Question Shuffling Allowed : Yes

Question Number : 11 Question Id : 3909003731 Question Type : MCQ Option Shuffling : Yes Display Question Number : Yes
Single Line Question Option : No Option Orientation : Vertical
Correct Marks : 1 Wrong Marks : 0

Stability in discrete domain is defined as

Options :

1. All the poles lie in the left half of plane
2. All the poles lie in the right half of plane
3. All the poles lie inside the unit circle centered at origin of Z plane
4. All the poles and zeros lie in the left half of plane

Question Number : 12 Question Id : 3909003732 Question Type : MCQ Option Shuffling : Yes Display Question Number : Yes
Single Line Question Option : No Option Orientation : Vertical
Correct Marks : 1 Wrong Marks : 0

Find the Seebeck emf for a material with $\alpha=50\mu\text{V}/^\circ\text{C}$ if the junction temperatures are 20°C and 100°C ?

Options :

1. 5 mV
2. 4 mV
3. 3.5 mV
4. 3 mV

Question Number : 13 Question Id : 3909003733 Question Type : MCQ Option Shuffling : Yes Display Question Number : Yes
Single Line Question Option : No Option Orientation : Vertical
Correct Marks : 1 Wrong Marks : 0

The hygrometer is used to measure _____

Options :

1. absolute humidity

2. relative humidity
3. humidity
4. specific humidity

Question Number : 14 Question Id : 3909003734 Question Type : MCQ Option Shuffling : Yes Display Question Number : Yes
Single Line Question Option : No Option Orientation : Vertical

Correct Marks : 1 Wrong Marks : 0

Which of the following principles is used by LVDT?

Options :

1. self-inductance
2. parasitic capacitance
3. mutual inductance
4. parasitic capacitance and inductance

Question Number : 15 Question Id : 3909003735 Question Type : MCQ Option Shuffling : Yes Display Question Number : Yes
Single Line Question Option : No Option Orientation : Vertical

Correct Marks : 1 Wrong Marks : 0

The open loop transfer function of unity feedback system is $G(s) = \frac{K}{s(s+1)(s^2+4s+5)}$.

If the system is stable for a range of K is

Options :

1. $0 < K < 8$
2. $0 < K < 18.88$
3. $0 < K < 10$
4. $0 > K > 18.88$

Question Number : 16 Question Id : 3909003736 Question Type : MCQ Option Shuffling : Yes Display Question Number : Yes
Single Line Question Option : No Option Orientation : Vertical

Correct Marks : 1 Wrong Marks : 0

A system is described by the state equation $\begin{bmatrix} \dot{x}_1 \\ \dot{x}_2 \end{bmatrix} = \begin{bmatrix} 2 & 0 \\ 0 & 2 \end{bmatrix} \begin{bmatrix} x_1 \\ x_2 \end{bmatrix} + \begin{bmatrix} 1 \\ 1 \end{bmatrix} u$. The state transition matrix of the system is

Options :

1. $\begin{bmatrix} e^{2t} & 0 \\ 0 & e^{2t} \end{bmatrix}$

2. $\begin{bmatrix} e^{-2t} & 0 \\ 0 & e^t \end{bmatrix}$

3. $\begin{bmatrix} e^{2t} & 1 \\ 1 & e^{2t} \end{bmatrix}$

4. $\begin{bmatrix} e^{-2t} & 0 \\ 0 & e^{-2t} \end{bmatrix}$

Question Number : 17 Question Id : 3909003737 Question Type : MCQ Option Shuffling : Yes Display Question Number : Yes
Single Line Question Option : No Option Orientation : Vertical

Correct Marks : 1 Wrong Marks : 0

The state matrix of the discrete system is given by

$$\dot{x}(k+1) = \begin{bmatrix} -2 & 1 \\ 1 & -2 \end{bmatrix} x(k) + \begin{bmatrix} 1 \\ 0 \end{bmatrix} u(k), \text{ then the system is}$$

Options :

1. Completely observable

2. Not completely observable

3. Completely controllable

4. Not Completely controllable

Question Number : 18 Question Id : 3909003738 Question Type : MCQ Option Shuffling : Yes Display Question Number : Yes
Single Line Question Option : No Option Orientation : Vertical

Correct Marks : 1 Wrong Marks : 0

Reduce the block diagram shown in the Figure and determine the final transfer function.

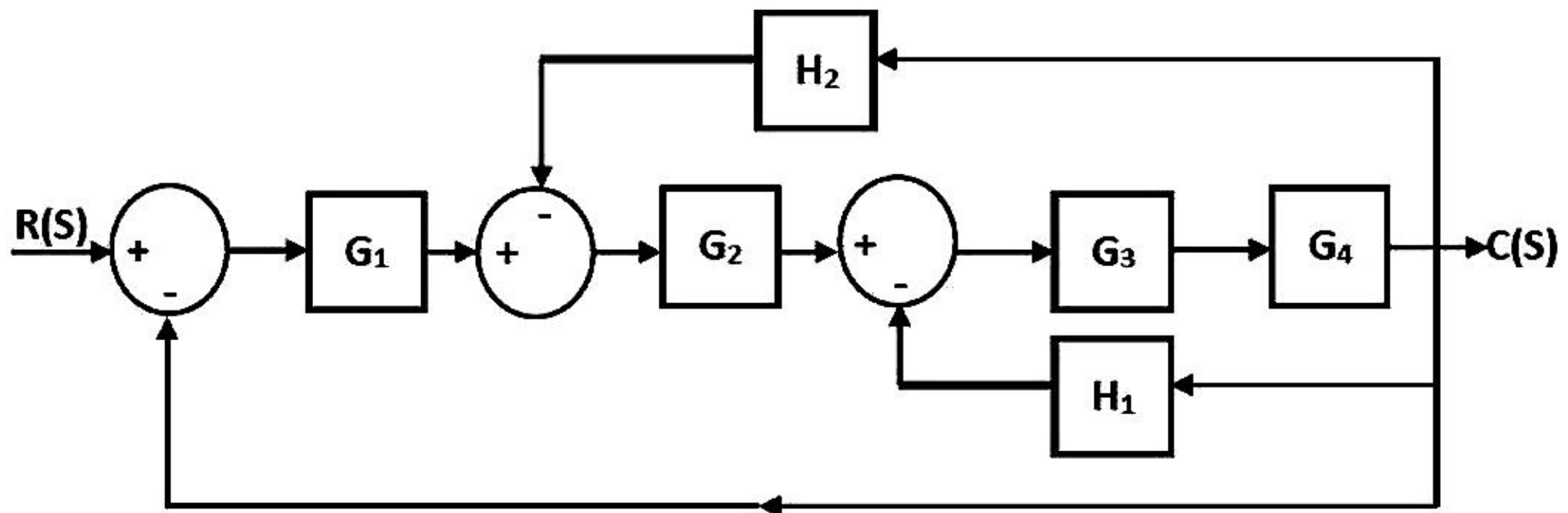

Options :

1. $\frac{C(s)}{R(s)} = \frac{G_1 G_2 G_3 G_4 H_1}{1 + G_3 G_4 + G_2 G_3 H_2 + G_1 G_2 G_3 G_4}$
2. $\frac{C(s)}{R(s)} = \frac{G_1 G_2 G_3 G_4}{1 + G_3 G_4 H_1 + G_2 G_3 H_2 + G_1 G_2 G_4}$
3. $\frac{C(s)}{R(s)} = \frac{G_1 G_2 G_3}{1 + G_3 G_4 H_1 + G_2 G_3 H_2 + G_2 G_3 G_4}$
4. $\frac{C(s)}{R(s)} = \frac{G_1 G_2 G_3 G_4}{1 + G_3 G_4 H_1 + G_2 G_3 G_4 H_2 + G_1 G_2 G_3 G_4}$

Question Number : 19 Question Id : 3909003739 Question Type : MCQ Option Shuffling : Yes Display Question Number : Yes Single Line Question Option : No Option Orientation : Vertical

Correct Marks : 1 Wrong Marks : 0

Consider a series RLC circuit excited by $v(t)$, and its loop current is $i(t)$. The transfer function $I(s)/V(s)$ of the network is

Options :

1. $\frac{C}{LCs^2 + RCs + 1}$

2.
$$\frac{Cs}{LCs^2 + RCs + 1}$$

3.
$$\frac{C}{RCs^2 + LCs + 1}$$

4.
$$\frac{Cs}{RCs^2 + LCs + 1}$$

Question Number : 20 Question Id : 3909003740 Question Type : MCQ Option Shuffling : Yes Display Question Number : Yes
 Single Line Question Option : No Option Orientation : Vertical
 Correct Marks : 1 Wrong Marks : 0

The open loop transfer function of a unity feedback system is given by:

$G(s) = K/s(s+2)(s+3)$. The centroid of a root locus is

Options :

1. $-5/3$

2. $-7/3$

3. $1/3$

4. $5/3$

Question Number : 21 Question Id : 3909003741 Question Type : MCQ Option Shuffling : Yes Display Question Number : Yes
 Single Line Question Option : No Option Orientation : Vertical
 Correct Marks : 1 Wrong Marks : 0

The open loop transfer function $G(s) = \frac{120}{s(s+6)}$ has a unity feedback. Find the steady state error when the input $r(t) = 1+5t$ is given to the system.

Options :

1. 0

2. $1/2$

3. Infinity

4. 1/4

Question Number : 22 Question Id : 3909003742 Question Type : MCQ Option Shuffling : Yes Display Question Number : Yes
Single Line Question Option : No Option Orientation : Vertical

Correct Marks : 1 Wrong Marks : 0

The system has a transfer function $G(s) = 1 / (1+0.1s)$. The Gain Margin (GM) of the system is

Options :

0

1.

Infinity

2.

20 dB

3.

40 dB

4.

Question Number : 23 Question Id : 3909003743 Question Type : MCQ Option Shuffling : Yes Display Question Number : Yes
Single Line Question Option : No Option Orientation : Vertical

Correct Marks : 1 Wrong Marks : 0

For the circuit shown below, the potential difference between points C and E (V_{CE}) is

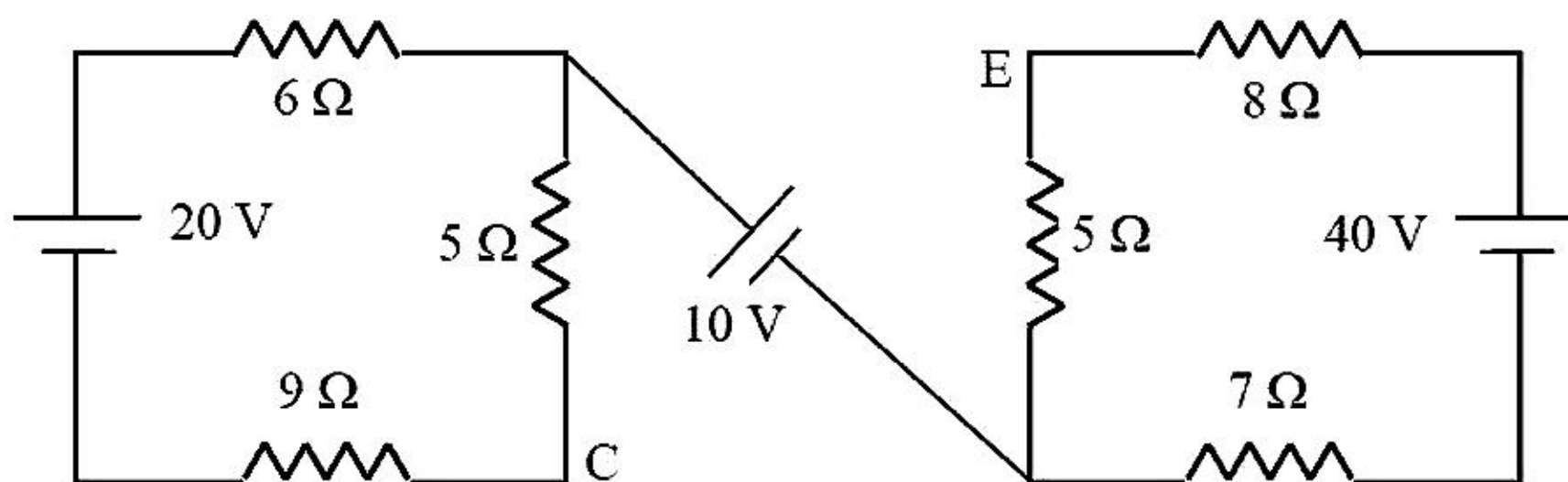

Options :

1. Node C is at a higher potential of 5 V with respect to node E

1.

2. Node C is at a lower potential of 5 V with respect to node E
3. Node C is at a higher potential of 10 V with respect to node E
4. Node C is at a lower potential of 10 V with respect to node E

Question Number : 24 Question Id : 3909003744 Question Type : MCQ Option Shuffling : Yes Display Question Number : Yes
Single Line Question Option : No Option Orientation : Vertical

Correct Marks : 1 Wrong Marks : 0

If the A, B, C, D parameters of a two port network are: $\begin{bmatrix} 2 & 3 \\ 1 & 2 \end{bmatrix}$, then the network is

Options :

1. Symmetrical and non reciprocal
2. Non Symmetrical and Non Reciprocal
3. Non -symmetrical and reciprocal
4. Symmetrical and reciprocal.

Question Number : 25 Question Id : 3909003745 Question Type : MCQ Option Shuffling : Yes Display Question Number : Yes
Single Line Question Option : No Option Orientation : Vertical

Correct Marks : 1 Wrong Marks : 0

The error in measurement whose sources and causes are not fixed is known as _____
error.

Options :

1. Gross
2. Random
3. Systematic
4. Instrumental

Question Number : 26 Question Id : 3909003746 Question Type : MCQ Option Shuffling : Yes Display Question Number : Yes
Single Line Question Option : No Option Orientation : Vertical
Correct Marks : 1 Wrong Marks : 0

The standard range of electronic and pneumatic signal transmission is

Options :

1. 0-20 mA, 0-15 psi.
2. 0-20 mA, 3-15 psi.
3. 4-20 mA, 0-15 psi.
4. 4-20 mA, 3-15 psi.

Question Number : 27 Question Id : 3909003747 Question Type : MCQ Option Shuffling : Yes Display Question Number : Yes
Single Line Question Option : No Option Orientation : Vertical
Correct Marks : 1 Wrong Marks : 0

If some values are recorded as 20, 30, 40 and 10, then the variance is

Options :

1. 25
2. $100/3$
3. $500/3$
4. 100

Question Number : 28 Question Id : 3909003748 Question Type : MCQ Option Shuffling : Yes Display Question Number : Yes
Single Line Question Option : No Option Orientation : Vertical
Correct Marks : 1 Wrong Marks : 0

The 'z' parameters of the network shown in Figure are

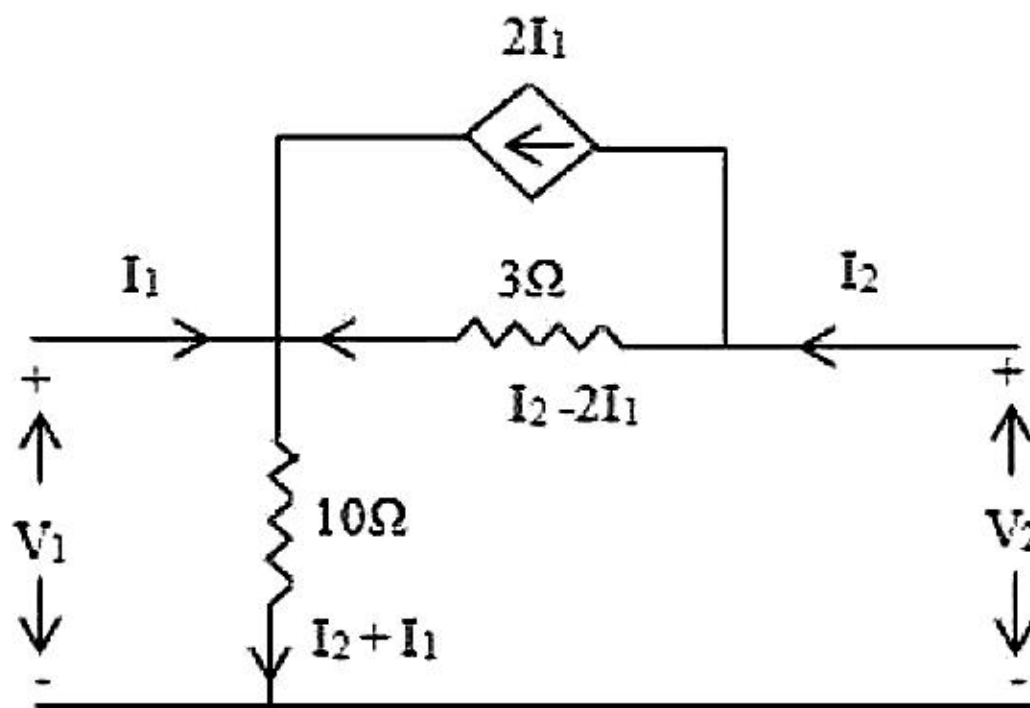

Options :

1. $\begin{bmatrix} 10 \Omega & 10 \Omega \\ 4 \Omega & 13 \Omega \end{bmatrix}$

2. $\begin{bmatrix} 10 \Omega & 10 \Omega \\ -4 \Omega & 13 \Omega \end{bmatrix}$

3. $\begin{bmatrix} 10 \Omega & 10 \Omega \\ -10 \Omega & -10 \Omega \end{bmatrix}$

4. $\begin{bmatrix} 10 \Omega & -10 \Omega \\ -11 \Omega & 11 \Omega \end{bmatrix}$

Question Number : 29 Question Id : 3909003749 Question Type : MCQ Option Shuffling : Yes Display Question Number : Yes
Single Line Question Option : No Option Orientation : Vertical

Correct Marks : 1 Wrong Marks : 0

Time constant of an RC circuit is defined as time during which the capacitor voltage actually rises to _____ % of its final steady value.

Options :

1. 63.2

2. 0.632

3. 36.8

4. 0.368

Question Number : 30 Question Id : 3909003750 Question Type : MCQ Option Shuffling : Yes Display Question Number : Yes
Single Line Question Option : No Option Orientation : Vertical
Correct Marks : 1 Wrong Marks : 0

The value of current 'i' in the network given in the Figure is

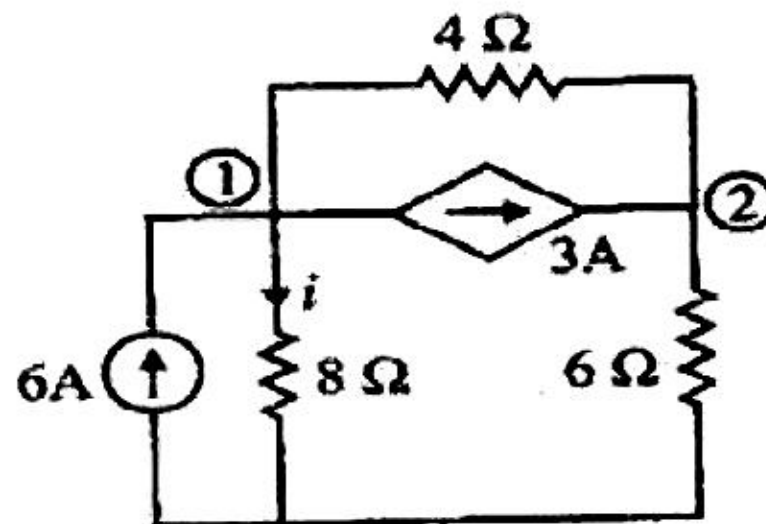

Options :

1. 2.6A

2. 2.8A

3. 3.2A

4. 2.1A

Question Number : 31 Question Id : 3909003751 Question Type : MCQ Option Shuffling : Yes Display Question Number : Yes
Single Line Question Option : No Option Orientation : Vertical
Correct Marks : 1 Wrong Marks : 0

Under maximum power transfer condition, the power transfer efficiency is only

Options :

1. 25%

2. 50%

3. 75%

4. 100%

Question Number : 32 Question Id : 3909003752 Question Type : MCQ Option Shuffling : Yes Display Question Number : Yes
Single Line Question Option : No Option Orientation : Vertical

Correct Marks : 1 Wrong Marks : 0

A thermometer has time constant of 1s. It is quickly taken from temperature 0°C to 100°C , then the temperature indicated after 1s is

Options :

1. 63.2°C

2. 50.2°C

3. 88.8°C

4. 25°C

Question Number : 33 Question Id : 3909003753 Question Type : MCQ Option Shuffling : Yes Display Question Number : Yes
Single Line Question Option : No Option Orientation : Vertical

Correct Marks : 1 Wrong Marks : 0

In measurement systems which of the following are undesirable static characteristics ?

Options :

1. Accuracy and Sensitivity

2. Resolution and Precision

3. Linearity and Reproducibility

4. Drift and dead zone

Question Number : 34 Question Id : 3909003754 Question Type : MCQ Option Shuffling : Yes Display Question Number : Yes
Single Line Question Option : No Option Orientation : Vertical

Correct Marks : 1 Wrong Marks : 0

The Thevenin's equivalent network is dual to _____ network.

Options :

1. Superposition
2. Reciprocity
3. Norton's
4. Max power theorem

Question Number : 35 Question Id : 3909003755 Question Type : MCQ Option Shuffling : Yes Display Question Number : Yes
Single Line Question Option : No Option Orientation : Vertical
Correct Marks : 1 Wrong Marks : 0

An ammeter of 0 – 25 A range has a guaranteed accuracy of 1% of full scale reading.
The current measured is 5 A. The limiting error is

Options :

1. 2%
2. 2.5%
3. 4%
4. 5%

Question Number : 36 Question Id : 3909003756 Question Type : MCQ Option Shuffling : Yes Display Question Number : Yes
Single Line Question Option : No Option Orientation : Vertical
Correct Marks : 1 Wrong Marks : 0

The resistor value is specified as $500 \Omega \pm 10\%$ by manufacturer. The limits of resistance between guaranteed value is

Options :

1. 450 Ω to 550 Ω
2. 500 Ω to 550 Ω

3. 400Ω to 500Ω

4. 450Ω to 600Ω

Question Number : 37 Question Id : 3909003757 Question Type : MCQ Option Shuffling : Yes Display Question Number : Yes
Single Line Question Option : No Option Orientation : Vertical
Correct Marks : 1 Wrong Marks : 0

The transmission parameter matrix of the following network is represented as

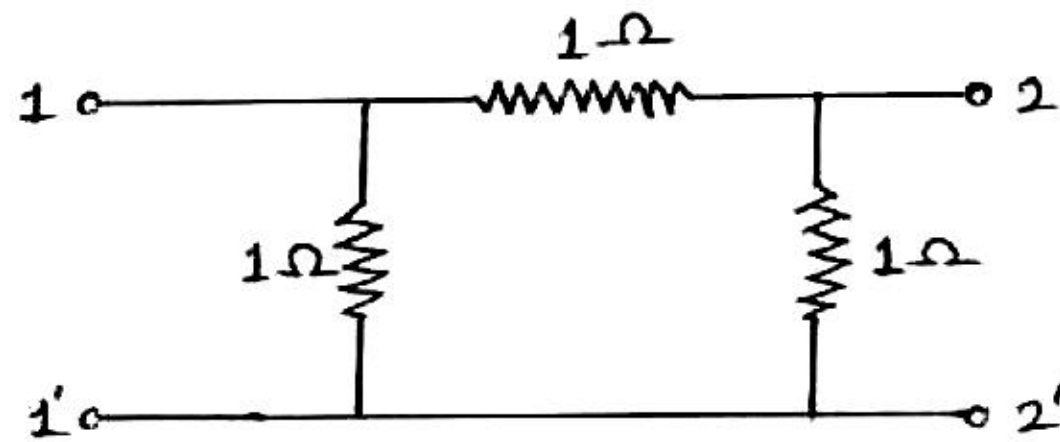

Options :

1. $\begin{bmatrix} 2 & 1 \\ 4 & 2 \end{bmatrix}$

2. $\begin{bmatrix} 2 & 1 \\ 3 & 2 \end{bmatrix}$

3. $\begin{bmatrix} 2 & 1 \\ 5 & 2 \end{bmatrix}$

4. $\begin{bmatrix} 2 & 1 \\ 3 & 4 \end{bmatrix}$

Question Number : 38 Question Id : 3909003758 Question Type : MCQ Option Shuffling : Yes Display Question Number : Yes
Single Line Question Option : No Option Orientation : Vertical
Correct Marks : 1 Wrong Marks : 0

The dead zone in certain pyrometer is 0.125% of span. The calibration is 400°C to 1000°C . The temperature change of _____ must occur before it is detected.

Options :

1. 0.85°C

2. 0.65°C
3. 0.75°C
4. 0.55°C

Question Number : 39 Question Id : 3909003759 Question Type : MCQ Option Shuffling : Yes Display Question Number : Yes
 Single Line Question Option : No Option Orientation : Vertical
 Correct Marks : 1 Wrong Marks : 0

An ac series circuit has resistance of $10\ \Omega$, an inductance of $0.2\ \text{H}$ and capacitance of $60\ \mu\text{F}$. When applied voltage is $200\ \text{V}$, the power at resonance is

Options :

1. $4\ \text{kW}$
2. $4.5\ \text{kW}$
3. $5.5\ \text{kW}$
4. $3\ \text{kW}$

Question Number : 40 Question Id : 3909003760 Question Type : MCQ Option Shuffling : Yes Display Question Number : Yes
 Single Line Question Option : No Option Orientation : Vertical
 Correct Marks : 1 Wrong Marks : 0

In two port network the mutual inductance of coupled inductors is 'M'. The Z parameters of the network shown in Figure is

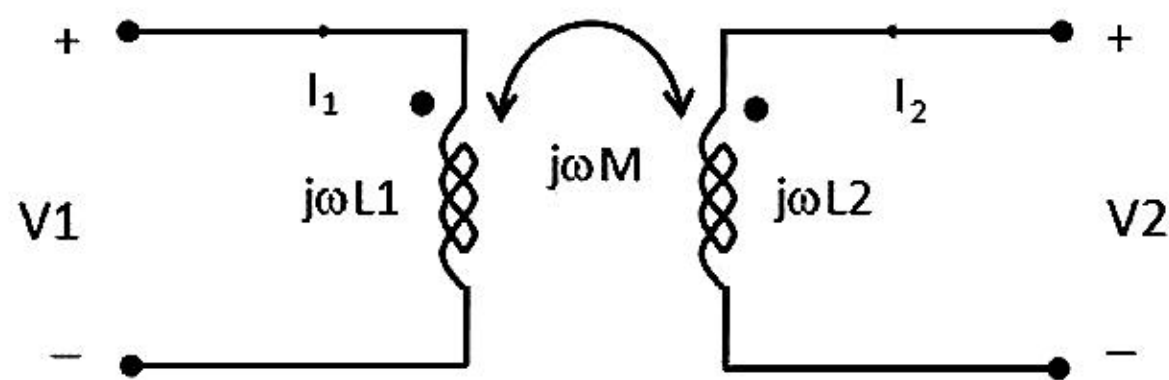

Options :

1. $\begin{bmatrix} j\omega L_1 & -j\omega M \\ -j\omega M & j\omega L_2 \end{bmatrix}$

2.
$$\begin{bmatrix} j\omega L1 & -j\omega M \\ j\omega M & j\omega L2 \end{bmatrix}$$

3.
$$\begin{bmatrix} j\omega L1 & j\omega M \\ -j\omega M & j\omega L2 \end{bmatrix}$$

4.
$$\begin{bmatrix} j\omega L1 & j\omega M \\ j\omega M & j\omega L2 \end{bmatrix}$$

Question Number : 41 Question Id : 3909003761 Question Type : MCQ Option Shuffling : Yes Display Question Number : Yes
Single Line Question Option : No Option Orientation : Vertical
Correct Marks : 1 Wrong Marks : 0

The systematic way of the network synthesis is performed by using

Options :

1. Cauer method
2. Superposition method
3. Thevenin's method
4. Max power technique

Question Number : 42 Question Id : 3909003762 Question Type : MCQ Option Shuffling : Yes Display Question Number : Yes
Single Line Question Option : No Option Orientation : Vertical
Correct Marks : 1 Wrong Marks : 0

The system is related by $y = 5*x+10$; y is the output and x is the input of the system.

It satisfies _____ property

Options :

1. Both additivity and homogeneity
2. Additivity and not homogeneity
3. Homogeneity and not additivity

4. Neither additivity nor homogeneity

Question Number : 43 Question Id : 3909003763 Question Type : MCQ Option Shuffling : Yes Display Question Number : Yes
Single Line Question Option : No Option Orientation : Vertical
Correct Marks : 1 Wrong Marks : 0

The principle of superposition theorem is applicable for _____ system.

Options :

1. Nonlinear
2. Non causal
3. Linear
4. Distributed

Question Number : 44 Question Id : 3909003764 Question Type : MCQ Option Shuffling : Yes Display Question Number : Yes
Single Line Question Option : No Option Orientation : Vertical
Correct Marks : 1 Wrong Marks : 0

For maximum power transfer to $3\ \Omega$ resistance, the value of R in the circuit given in Figure is

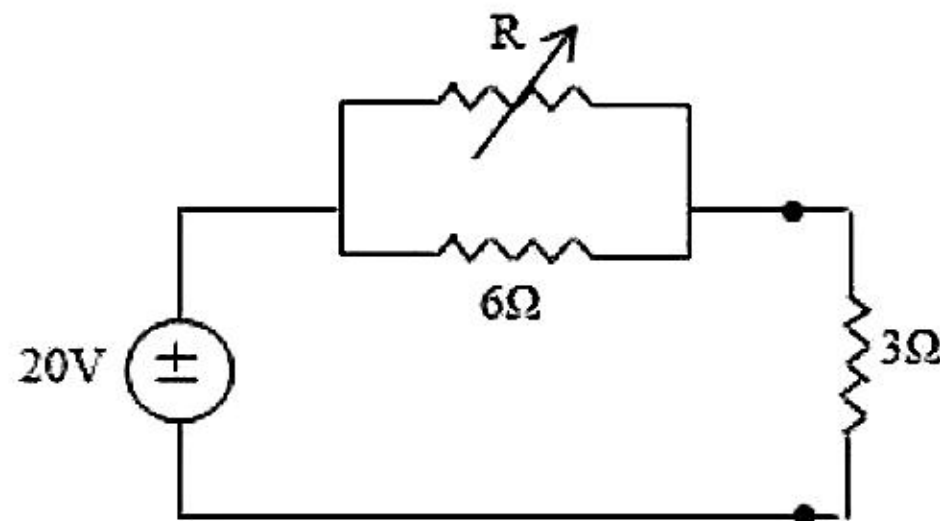

Options :

1. $3\ \Omega$
2. $6\ \Omega$
3. $9\ \Omega$

4. 12Ω

Question Number : 45 Question Id : 3909003765 Question Type : MCQ Option Shuffling : Yes Display Question Number : Yes
Single Line Question Option : No Option Orientation : Vertical

Correct Marks : 1 Wrong Marks : 0

The magnitude of current (I_L) in circuit given in Figure is

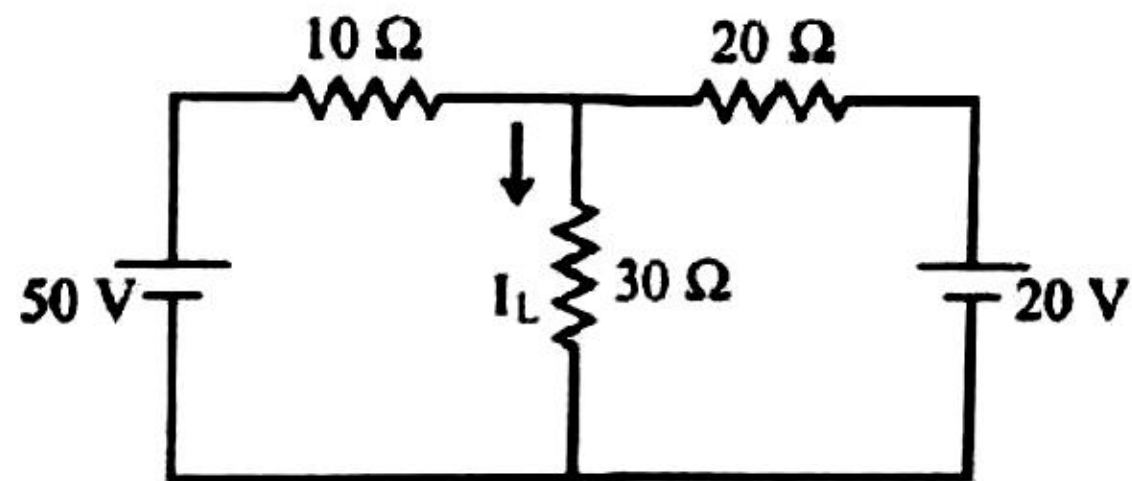

Options :

1. 1.29 A
2. 1.09 A
3. 2.15 A
4. 1.59 A

Question Number : 46 Question Id : 3909003766 Question Type : MCQ Option Shuffling : Yes Display Question Number : Yes
Single Line Question Option : No Option Orientation : Vertical

Correct Marks : 1 Wrong Marks : 0

The 'h' parameters of the circuit shown in Figure are:

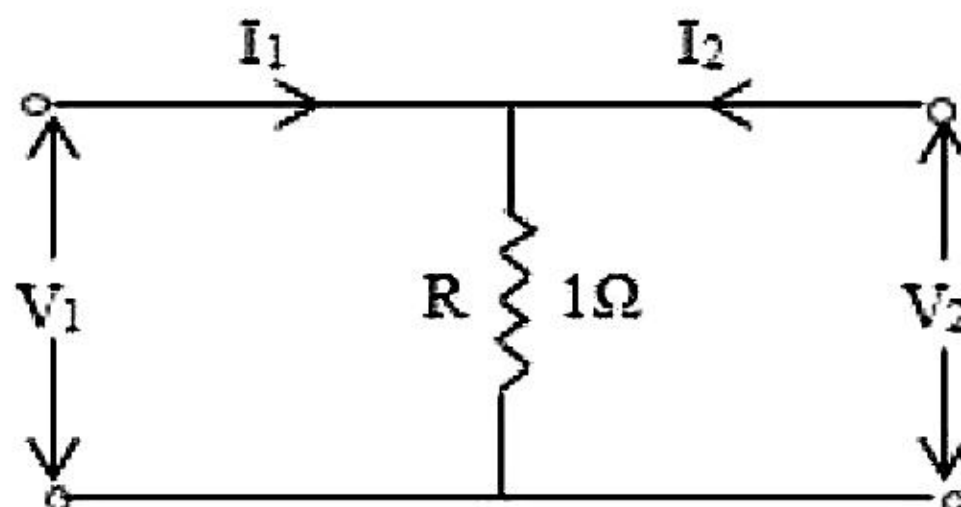

Options :

1. $\begin{bmatrix} 0 & -1 \\ -1 & -1 \end{bmatrix}$

2. $\begin{bmatrix} 0 & 1 \\ -1 & 1 \end{bmatrix}$

3. $\begin{bmatrix} 0 & 1 \\ -1 & -1 \end{bmatrix}$

4. $\begin{bmatrix} 0 & -1 \\ -1 & 1 \end{bmatrix}$

Question Number : 47 Question Id : 3909003767 Question Type : MCQ Option Shuffling : Yes Display Question Number : Yes
Single Line Question Option : No Option Orientation : Vertical
Correct Marks : 1 Wrong Marks : 0

The thermistor characteristic is

Options :

1. Linear and high sensitivity
2. Non-linear and low sensitivity
3. Linear and low sensitivity
4. Non-linear and high sensitivity

Question Number : 48 Question Id : 3909003768 Question Type : MCQ Option Shuffling : Yes Display Question Number : Yes
Single Line Question Option : No Option Orientation : Vertical
Correct Marks : 1 Wrong Marks : 0

Three resistors $R_1 = 37\Omega \pm 5\%$, $R_2 = 75\Omega \pm 5\%$ and $R_3 = 50\Omega \pm 5\%$. Determine limiting error in ohm and in percent of the resistance of these resistances connected in series.

Options :

1. $\pm 9.25\Omega$, $\pm 15\%$
2. $\pm 8.1\Omega$, $\pm 15\%$

3. $\pm 9.25 \Omega$, $\pm 5\%$

4. $\pm 8.1 \Omega$, $\pm 5\%$

Question Number : 49 Question Id : 3909003769 Question Type : MCQ Option Shuffling : Yes Display Question Number : Yes
Single Line Question Option : No Option Orientation : Vertical

Correct Marks : 1 Wrong Marks : 0

Permanent magnet moving coil (PMMC) galvanometer is used for _____
current measurement.

Options :

1. DC

2. AC

3. DC & AC

4. Pulsating AC

Question Number : 50 Question Id : 3909003770 Question Type : MCQ Option Shuffling : Yes Display Question Number : Yes
Single Line Question Option : No Option Orientation : Vertical

Correct Marks : 1 Wrong Marks : 0

A 1mA meter movement with an internal resistance of 100Ω is to be converted into
(0-101) mA then the value of shunt resistance is

Options :

1. 100Ω

2. 10Ω

3. 1Ω

4. 50Ω

Question Number : 51 Question Id : 3909003771 Question Type : MCQ Option Shuffling : Yes Display Question Number : Yes
Single Line Question Option : No Option Orientation : Vertical

Correct Marks : 1 Wrong Marks : 0

The SI unit of specific resistance or resistivity is

Options :

1. Ω -meter
2. Ω -meter²
3. Ω -cm
4. Ω /meter

Question Number : 52 Question Id : 3909003772 Question Type : MCQ Option Shuffling : Yes Display Question Number : Yes
Single Line Question Option : No Option Orientation : Vertical

Correct Marks : 1 Wrong Marks : 0

In figure, $Z_1 = 200\angle 60^\circ\Omega$, $Z_2 = 400\angle -90^\circ\Omega$, $Z_3 = 300\angle 0^\circ\Omega$. Then Z_4 for bridge to be balanced is

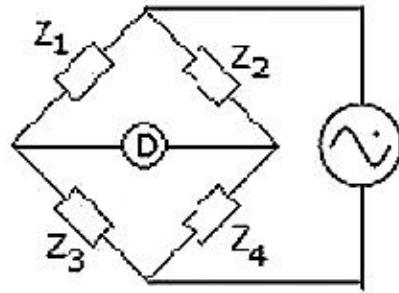

Options :

1. $150\angle 30^\circ\Omega$
2. $400\angle -90^\circ\Omega$
3. $300\angle 90^\circ\Omega$
4. $600\angle -150^\circ\Omega$

Question Number : 53 Question Id : 3909003773 Question Type : MCQ Option Shuffling : Yes Display Question Number : Yes
Single Line Question Option : No Option Orientation : Vertical

Correct Marks : 1 Wrong Marks : 0

A dynamometer wattmeter is connected in ac circuit. The reading will be

Options :

1. VA product
2. Average power
3. Peak power
4. Instantaneous power

Question Number : 54 Question Id : 3909003774 Question Type : MCQ Option Shuffling : Yes Display Question Number : Yes
Single Line Question Option : No Option Orientation : Vertical
Correct Marks : 1 Wrong Marks : 0

In CRT the focussing anode is located _____

Options :

1. between pre-accelerating and accelerating anode
2. after accelerating anode
3. before pre-accelerating anode
4. Between horizontal and vertical deflection plates

Question Number : 55 Question Id : 3909003775 Question Type : MCQ Option Shuffling : Yes Display Question Number : Yes
Single Line Question Option : No Option Orientation : Vertical
Correct Marks : 1 Wrong Marks : 0

Energy meter runs slowly even if power is not used. This error is called

Options :

1. Speed error
2. Phase error
3. Creeping error
4. Ratio error

Question Number : 56 Question Id : 3909003776 Question Type : MCQ Option Shuffling : Yes Display Question Number : Yes
Single Line Question Option : No Option Orientation : Vertical
Correct Marks : 1 Wrong Marks : 0

A vertical amplifier for a CRO is designed for

Options :

1. Only a high gain
2. Only a broad bandwidth
3. Constant gain bandwidth product
4. Variable gain

Question Number : 57 Question Id : 3909003777 Question Type : MCQ Option Shuffling : Yes Display Question Number : Yes
Single Line Question Option : No Option Orientation : Vertical
Correct Marks : 1 Wrong Marks : 0

The Lissajous pattern observed on screen of CRO is a straight line inclined at 45° to positive x-axis. If X-plate input is $2 \sin \omega t$, the Y-plate input is

Options :

1. $2 \sin \omega t$
2. $2 \sin (\omega t + 45^\circ)$
3. $2 \sin (\omega t - 45^\circ)$
4. $2.818 \sin (\omega t + 45^\circ)$

Question Number : 58 Question Id : 3909003778 Question Type : MCQ Option Shuffling : Yes Display Question Number : Yes
Single Line Question Option : No Option Orientation : Vertical
Correct Marks : 1 Wrong Marks : 0

Which of following represents an active transducer?

Options :

1. Strain gauge
2. Thermistor

3. LVDT

4. Thermocouple

Question Number : 59 Question Id : 3909003779 Question Type : MCQ Option Shuffling : Yes Display Question Number : Yes
Single Line Question Option : No Option Orientation : Vertical
Correct Marks : 1 Wrong Marks : 0

The gauge factor of semiconductor strain gauge is _____

Options :

1. Low

2. Medium

3. High

4. Zero

Question Number : 60 Question Id : 3909003780 Question Type : MCQ Option Shuffling : Yes Display Question Number : Yes
Single Line Question Option : No Option Orientation : Vertical
Correct Marks : 1 Wrong Marks : 0

The flow meter which has high Coefficient discharge is _____

Options :

1. Orifice

2. Flow nozzle

3. Pitot tube

4. Rotameter

Question Number : 61 Question Id : 3909003781 Question Type : MCQ Option Shuffling : Yes Display Question Number : Yes
Single Line Question Option : No Option Orientation : Vertical
Correct Marks : 1 Wrong Marks : 0

The highly accurate flow meter is _____

Options :

1. Rotameter
2. Turbine flow meter
3. Vortex flow meter
4. Orifice

Question Number : 62 Question Id : 3909003782 Question Type : MCQ Option Shuffling : Yes Display Question Number : Yes
Single Line Question Option : No Option Orientation : Vertical

Correct Marks : 1 Wrong Marks : 0

The Pyrometer is used to measure _____

Options :

1. High pressure
2. Low temperature
3. High Temperature
4. Low pressure

Question Number : 63 Question Id : 3909003783 Question Type : MCQ Option Shuffling : Yes Display Question Number : Yes
Single Line Question Option : No Option Orientation : Vertical

Correct Marks : 1 Wrong Marks : 0

The dead weight tester is used for _____

Options :

1. Temperature calibration
2. Pressure calibration
3. Flow Calibration
4. Level Calibration

Question Number : 64 Question Id : 3909003784 Question Type : MCQ Option Shuffling : Yes Display Question Number : Yes
Single Line Question Option : No Option Orientation : Vertical

Correct Marks : 1 Wrong Marks : 0

An LVDT has a full range output of ± 5.2 V with range of ± 0.5 in. Find out output voltage when the core is -0.25 in. from the centre is _____

Options :

1. -2.6 V
2. 2.6 V
3. -3.1 V
4. 3.1 V

Question Number : 65 Question Id : 3909003785 Question Type : MCQ Option Shuffling : Yes Display Question Number : Yes
Single Line Question Option : No Option Orientation : Vertical
Correct Marks : 1 Wrong Marks : 0

Phonocardiogram is the record of _____

Options :

1. arm muscle sound
2. lungs sound
3. heart sound
4. respiratory tract sound

Question Number : 66 Question Id : 3909003786 Question Type : MCQ Option Shuffling : Yes Display Question Number : Yes
Single Line Question Option : No Option Orientation : Vertical
Correct Marks : 1 Wrong Marks : 0

The resting potential of a neuron is about _____

Options :

1. $+70$ mV
2. -70 mV
3. $+20$ mV

4. -20 mV

Question Number : 67 Question Id : 3909003787 Question Type : MCQ Option Shuffling : Yes Display Question Number : Yes
Single Line Question Option : No Option Orientation : Vertical

Correct Marks : 1 Wrong Marks : 0

Process of changing resting potential to action potential is known as _____

Options :

1. Polarization
2. Re-polarization
3. Depolarization
4. Uni-polarization

Question Number : 68 Question Id : 3909003788 Question Type : MCQ Option Shuffling : Yes Display Question Number : Yes
Single Line Question Option : No Option Orientation : Vertical

Correct Marks : 1 Wrong Marks : 0

Optical fiber operates on the principle of

Options :

1. Tyndall effect
2. Total internal reflectance
3. Photo electric effect
4. Laser technology

Question Number : 69 Question Id : 3909003789 Question Type : MCQ Option Shuffling : Yes Display Question Number : Yes
Single Line Question Option : No Option Orientation : Vertical

Correct Marks : 1 Wrong Marks : 0

Which of the following is an integrating type ADC?

Options :

1. Successive approximation ADC
2. Dual slope ADC

3. Flash ADC
4. R- 2R ladder network ADC

Question Number : 70 Question Id : 3909003790 Question Type : MCQ Option Shuffling : Yes Display Question Number : Yes
Single Line Question Option : No Option Orientation : Vertical
Correct Marks : 1 Wrong Marks : 0

EMG is the measure of _____

Options :

1. The electrical activity of the heart
2. The electrical activity of the visual cortex
3. The electrical activity of the muscle
4. The electrical activity of the brain

Question Number : 71 Question Id : 3909003791 Question Type : MCQ Option Shuffling : Yes Display Question Number : Yes
Single Line Question Option : No Option Orientation : Vertical
Correct Marks : 1 Wrong Marks : 0

LED's are made up of _____

Options :

1. Silicon
2. Germanium
3. Gallium Arsenide
4. Platinum

Question Number : 72 Question Id : 3909003792 Question Type : MCQ Option Shuffling : Yes Display Question Number : Yes
Single Line Question Option : No Option Orientation : Vertical
Correct Marks : 1 Wrong Marks : 0

Which of the following relates the attenuation of light to the properties of the material through which the light is travelling?

Options :

1. Snell's law
2. Raman effect
3. Beer's law
4. Huygens-Fresnel equation

Question Number : 73 Question Id : 3909003793 Question Type : MCQ Option Shuffling : Yes Display Question Number : Yes
Single Line Question Option : No Option Orientation : Vertical
Correct Marks : 1 Wrong Marks : 0

Photo resistors are light sensitive resistors whose resistance _____ as the intensity of light they are exposed to increases.

Options :

1. Decreases
2. Increases
3. Remains constant
4. Becomes zero

Question Number : 74 Question Id : 3909003794 Question Type : MCQ Option Shuffling : Yes Display Question Number : Yes
Single Line Question Option : No Option Orientation : Vertical
Correct Marks : 1 Wrong Marks : 0

What is the numerical aperture of a fiber with core and cladding refraction indices as 1.5 and 1.2 respectively?

Options :

1. 0.9
2. 0.81
3. 0.3

4. 3.69

Question Number : 75 Question Id : 3909003795 Question Type : MCQ Option Shuffling : Yes Display Question Number : Yes
Single Line Question Option : No Option Orientation : Vertical
Correct Marks : 1 Wrong Marks : 0

Which of the following interrupts is non-maskable interrupt?

Options :

1. RST 5.5
2. TRAP
3. RST 7.5
4. INTR

Question Number : 76 Question Id : 3909003796 Question Type : MCQ Option Shuffling : Yes Display Question Number : Yes
Single Line Question Option : No Option Orientation : Vertical
Correct Marks : 1 Wrong Marks : 0

The modulation index of an amplitude modulated wave is changed from 0 to 1. The transmitted power is:

Options :

1. Halved
2. Doubled
3. Increased by 50%
4. Unchanged

Question Number : 77 Question Id : 3909003797 Question Type : MCQ Option Shuffling : Yes Display Question Number : Yes
Single Line Question Option : No Option Orientation : Vertical
Correct Marks : 1 Wrong Marks : 0

In frequency modulation, if the frequency of the modulating voltage is doubled, the rate of deviation of carrier frequency is

Options :

1. Halved

2. Doubled
3. Four times
4. Unchanged

Question Number : 78 Question Id : 3909003798 Question Type : MCQ Option Shuffling : Yes Display Question Number : Yes
Single Line Question Option : No Option Orientation : Vertical

Correct Marks : 1 Wrong Marks : 0

A sinusoidal message signal of frequency 15 kHz is used to generate a standard FM signal with a modulation index of 5, the approximate bandwidth according to Carson's rule is

Options :

1. 15 k Hz
2. 30 kHz
3. 90 kHz
4. 180 kHz

Question Number : 79 Question Id : 3909003799 Question Type : MCQ Option Shuffling : Yes Display Question Number : Yes
Single Line Question Option : No Option Orientation : Vertical

Correct Marks : 1 Wrong Marks : 0

The Laplace transform of te^{-at} is

Options :

1. $\frac{s}{(s-a)^2}$
2. $\frac{1}{(s-a)^2}$
3. $\frac{s}{(s+a)^2}$

4. $\frac{1}{(s+a)^2}$

Question Number : 80 Question Id : 3909003800 Question Type : MCQ Option Shuffling : Yes Display Question Number : Yes
Single Line Question Option : No Option Orientation : Vertical

Correct Marks : 1 Wrong Marks : 0

The maximum permissible duration between two samples of a 2 kHz signal is

Options :

1. 100 μ sec
2. 10 μ sec
3. 250 μ sec
4. 500 μ sec

Question Number : 81 Question Id : 3909003801 Question Type : MCQ Option Shuffling : Yes Display Question Number : Yes
Single Line Question Option : No Option Orientation : Vertical

Correct Marks : 1 Wrong Marks : 0

The sequence of operations done in pulse code modulation is

Options :

1. Encoding, quantization and sampling
2. Quantization, encoding and sampling
3. Sampling, quantization and encoding
4. Encoding, comparator and sampling

Question Number : 82 Question Id : 3909003802 Question Type : MCQ Option Shuffling : Yes Display Question Number : Yes
Single Line Question Option : No Option Orientation : Vertical

Correct Marks : 1 Wrong Marks : 0

The Fourier transform of unit step function $u(t)$ is

Options :

1. $\frac{1}{j\omega} + \pi \delta(\omega)$

2. $\frac{1}{j\omega}$

3. $2\delta(\omega) + \frac{1}{j\omega}$

4. $\delta(\omega) + \text{sgn}(\omega)$

Question Number : 83 Question Id : 3909003803 Question Type : MCQ Option Shuffling : Yes Display Question Number : Yes
Single Line Question Option : No Option Orientation : Vertical
Correct Marks : 1 Wrong Marks : 0

A carrier is modulated by a digital bit stream having one of the possible phases of 0° , 90° , 180° , 270° . Then the modulation is termed as

Options :

1. BPSK

2. QPSK

3. QAM

4. MSK

Question Number : 84 Question Id : 3909003804 Question Type : MCQ Option Shuffling : Yes Display Question Number : Yes
Single Line Question Option : No Option Orientation : Vertical
Correct Marks : 1 Wrong Marks : 0

The _____ bridge is used for measurement of unknown capacitance.

Options :

1. Wheat Stone

2. Maxwell
3. Kelvin's double
4. Schering

Question Number : 85 Question Id : 3909003805 Question Type : MCQ Option Shuffling : Yes Display Question Number : Yes
Single Line Question Option : No Option Orientation : Vertical

Correct Marks : 1 Wrong Marks : 0

If the pH of a solution is 3, then it is _____

Options :

1. Acidic
2. Basic
3. Neither acidic nor basic
4. Neutral

Question Number : 86 Question Id : 3909003806 Question Type : MCQ Option Shuffling : Yes Display Question Number : Yes
Single Line Question Option : No Option Orientation : Vertical

Correct Marks : 1 Wrong Marks : 0

Which of the following is the difference equation of the FIR filter of length M, input $x(n)$ and output $y(n)$?

Options :

1. $y(n) = \sum_{k=0}^{M+1} b_k x(n+k)$
2. $y(n) = \sum_{k=0}^{M-1} b_k x(n-k)$
3. $y(n) = \sum_{k=0}^{M+1} b_k x(n-k)$
4. $y(n) = \sum_{k=0}^M b_k x(n+k)$

Question Number : 87 Question Id : 3909003807 Question Type : MCQ Option Shuffling : Yes Display Question Number : Yes
Single Line Question Option : No Option Orientation : Vertical
Correct Marks : 1 Wrong Marks : 0

The universal gate is _____

Options :

1. NAND gate
2. OR gate
3. AND gate
4. XOR gate

Question Number : 88 Question Id : 3909003808 Question Type : MCQ Option Shuffling : Yes Display Question Number : Yes
Single Line Question Option : No Option Orientation : Vertical
Correct Marks : 1 Wrong Marks : 0

2's complement of binary number 0111 is

Options :

1. 1001
2. 1111
3. 1000
4. 1110

Question Number : 89 Question Id : 3909003809 Question Type : MCQ Option Shuffling : Yes Display Question Number : Yes
Single Line Question Option : No Option Orientation : Vertical
Correct Marks : 1 Wrong Marks : 0

A ring counter with 4 flip flops and the number of states is equal to

Options :

1. 4
2. 8
3. 16

4. 32

Question Number : 90 Question Id : 3909003810 Question Type : MCQ Option Shuffling : Yes Display Question Number : Yes
Single Line Question Option : No Option Orientation : Vertical
Correct Marks : 1 Wrong Marks : 0

The minterms for the sum of a full adder is

Options :

1. 1,2,3,4
2. 1,2,4,7
3. 1,5,6,7
4. 2,4,6,8

Question Number : 91 Question Id : 3909003811 Question Type : MCQ Option Shuffling : Yes Display Question Number : Yes
Single Line Question Option : No Option Orientation : Vertical
Correct Marks : 1 Wrong Marks : 0

The Boolean expression for the circuit given in Figure is

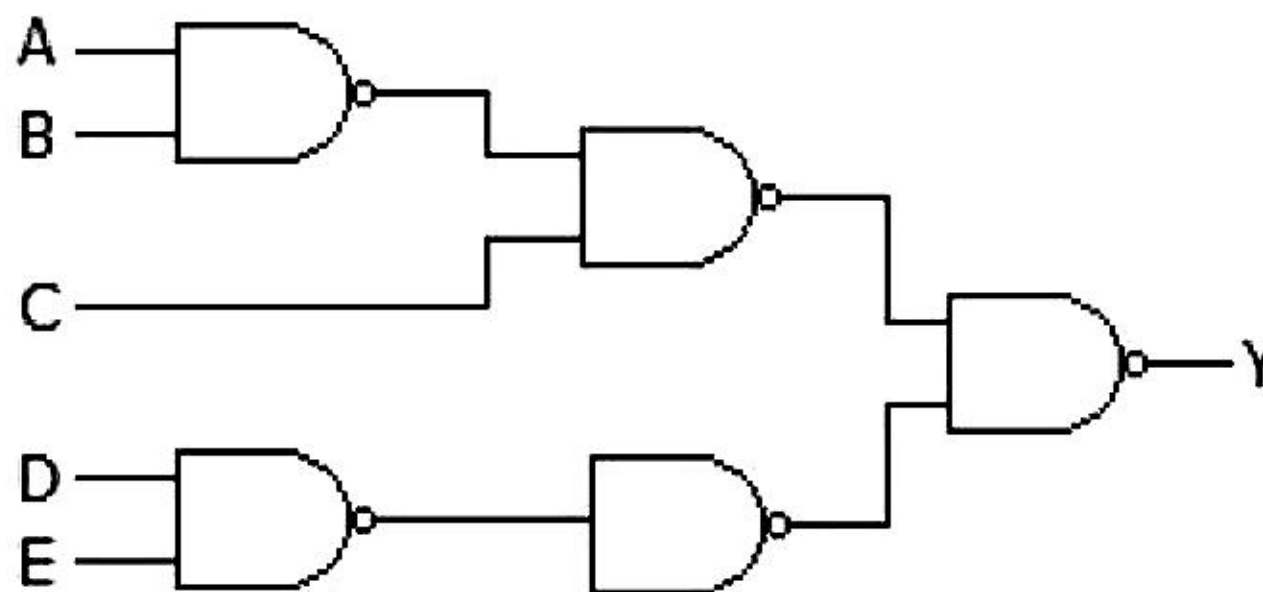

Options :

1. $(\bar{A} + \bar{B})C + \bar{D}\bar{E}$
2. $(\bar{A} + \bar{B}) + \bar{C} + DE$
3. $(\bar{A} + \bar{B}) + C + \bar{D} + E$
4. $ABC + DE$

Question Number : 92 Question Id : 3909003812 Question Type : MCQ Option Shuffling : Yes Display Question Number : Yes
Single Line Question Option : No Option Orientation : Vertical
Correct Marks : 1 Wrong Marks : 0

In the logic equation $A(A + \bar{B}\bar{C} + C) + \bar{B}(\bar{C} + \bar{A} + BC)(A + \bar{B}C + A\bar{C})$, If $C = \bar{A}$,
then it is simplified as

Options :

1. $A + B$
2. $\bar{A} + B$
3. $A + \bar{B}$
4. A

Question Number : 93 Question Id : 3909003813 Question Type : MCQ Option Shuffling : Yes Display Question Number : Yes
Single Line Question Option : No Option Orientation : Vertical
Correct Marks : 1 Wrong Marks : 0

A binary code that progresses such that only one bit changes between two successive
codes is

Options :

1. Self-complementary
2. Gray code
3. Excess 3 code
4. BCD

Question Number : 94 Question Id : 3909003814 Question Type : MCQ Option Shuffling : Yes Display Question Number : Yes
Single Line Question Option : No Option Orientation : Vertical
Correct Marks : 1 Wrong Marks : 0

In a 4-to-1 multiplexer given in Figure, if $C_1 = 0$ and $C_0 = 1$ then the output M is

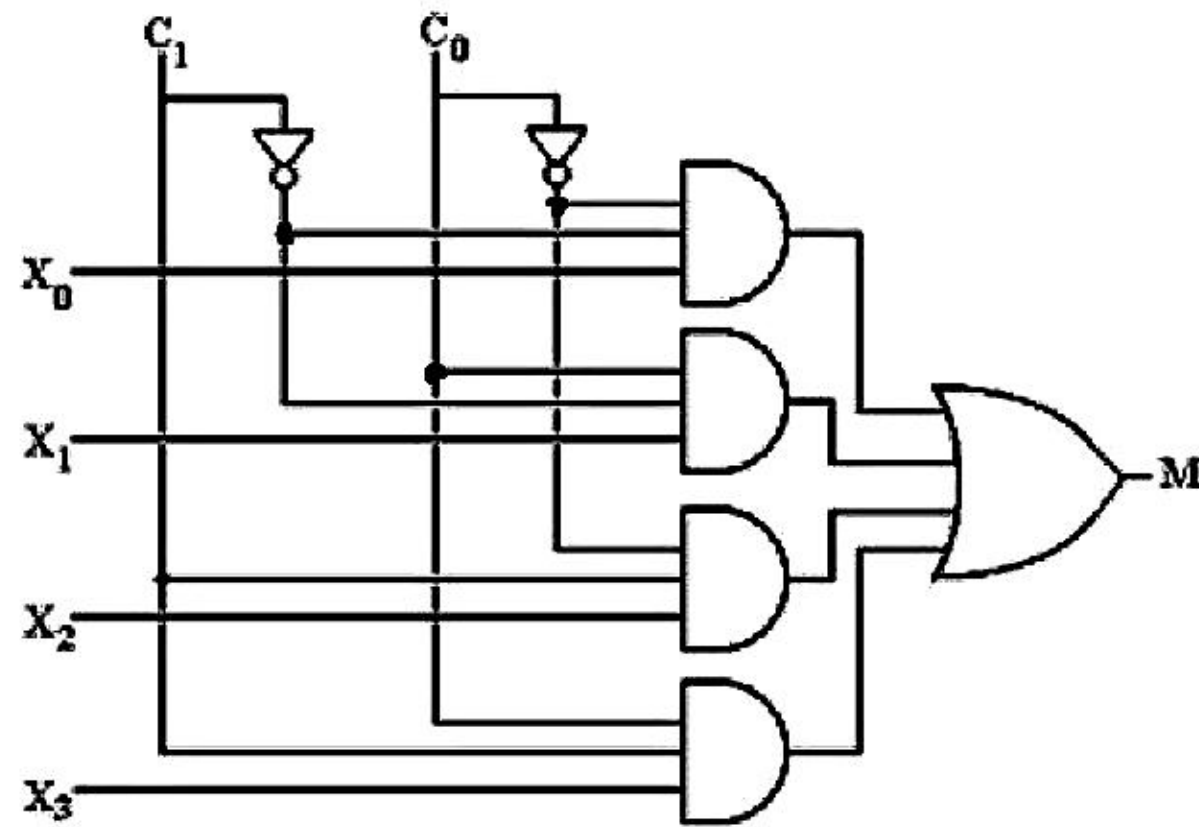

Options :

1. X_0
2. X_1
3. X_2
4. X_3

Question Number : 95 Question Id : 3909003815 Question Type : MCQ Option Shuffling : Yes Display Question Number : Yes
Single Line Question Option : No Option Orientation : Vertical
Correct Marks : 1 Wrong Marks : 0

SR flip flop can be converted into D flip flop by connecting _____ between S and R.

Options :

1. E-XOR gate
2. NOT gate
3. AND gate
4. Multiplexer

Question Number : 96 Question Id : 3909003816 Question Type : MCQ Option Shuffling : Yes Display Question Number : Yes
Single Line Question Option : No Option Orientation : Vertical

TS PGECET 2019

Correct Marks : 1 Wrong Marks : 0

The minimum number of comparators required to build an 8 bit flash ADC is

Options :

1. 64
2. 63
3. 255
4. 256

Question Number : 97 Question Id : 3909003817 Question Type : MCQ Option Shuffling : Yes Display Question Number : Yes
Single Line Question Option : No Option Orientation : Vertical

Correct Marks : 1 Wrong Marks : 0

A 12 bit dual ramp generation has a maximum output voltage of +12 V. Compute the equivalent digital number for the analog signal of +6 V.

Options :

1. 100000000001
2. 100000000010
3. 010000000000
4. 100000000000

Question Number : 98 Question Id : 3909003818 Question Type : MCQ Option Shuffling : Yes Display Question Number : Yes
Single Line Question Option : No Option Orientation : Vertical

Correct Marks : 1 Wrong Marks : 0

The smallest resistor in a 12 bit weighted resistor DAC is 2.5 k Ω , what will be the largest resistor value?

Options :

1. 40.96 M Ω
2. 10.24 M Ω
3. 61.44 M Ω

4. 18.43 MΩ

Question Number : 99 Question Id : 3909003819 Question Type : MCQ Option Shuffling : Yes Display Question Number : Yes
Single Line Question Option : No Option Orientation : Vertical
Correct Marks : 1 Wrong Marks : 0

Voltage rating of a Zener diode denotes

Options :

1. Reverse breakdown voltage
2. Forward breakdown voltage
3. Voltage at which current is maximum
4. Maximum forward voltage which a diode can withstand

Question Number : 100 Question Id : 3909003820 Question Type : MCQ Option Shuffling : Yes Display Question Number : Yes
Single Line Question Option : No Option Orientation : Vertical
Correct Marks : 1 Wrong Marks : 0

At 3dB cut-off frequency the voltage gain will be

Options :

1. 100% of maximum gain
2. 70.7% of maximum gain
3. 80.7% of maximum gain
4. 47.5% of maximum gain

Question Number : 101 Question Id : 3909003821 Question Type : MCQ Option Shuffling : Yes Display Question Number : Yes
Single Line Question Option : No Option Orientation : Vertical
Correct Marks : 1 Wrong Marks : 0

RC phase shift oscillator contains a minimum of _____ Phase shift network (s).

Options :

1. one

2. two
3. three
4. zero

Question Number : 102 Question Id : 3909003822 Question Type : MCQ Option Shuffling : Yes Display Question Number : Yes
 Single Line Question Option : No Option Orientation : Vertical
 Correct Marks : 1 Wrong Marks : 0

The output V_0 in Figure is

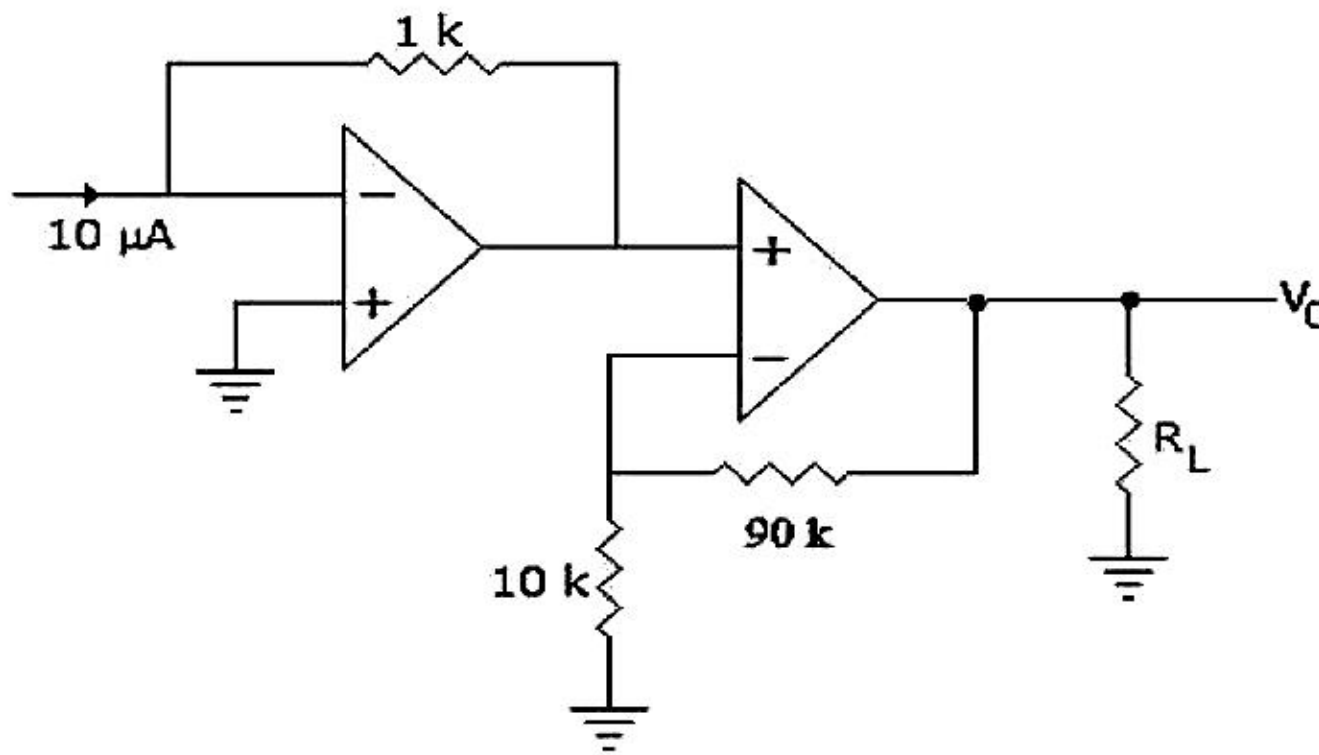

Options :

1. -100 V
2. -100 mV
3. 10 V
4. 10 mV

Question Number : 103 Question Id : 3909003823 Question Type : MCQ Option Shuffling : Yes Display Question Number : Yes
 Single Line Question Option : No Option Orientation : Vertical
 Correct Marks : 1 Wrong Marks : 0

In class C operation of an amplifier circuit, the collector current exists for

Options :

1. 360° of input wave
2. 180° of input wave
3. more than 180° of input wave
4. less than 180° of input wave

Question Number : 104 Question Id : 3909003824 Question Type : MCQ Option Shuffling : Yes Display Question Number : Yes
Single Line Question Option : No Option Orientation : Vertical
Correct Marks : 1 Wrong Marks : 0

Integral control improves _____

Options :

1. Transient response
2. Steady state response
3. Raise time
4. Settling time

Question Number : 105 Question Id : 3909003825 Question Type : MCQ Option Shuffling : Yes Display Question Number : Yes
Single Line Question Option : No Option Orientation : Vertical
Correct Marks : 1 Wrong Marks : 0

The transducer used for measurement of pressure less than 1 atmosphere is

Options :

1. Bourdon gauge
2. Pirani gauge
3. Solid state pressure gauge
4. LVDT pressure gauge

Question Number : 106 Question Id : 3909003826 Question Type : MCQ Option Shuffling : Yes Display Question Number : Yes
Single Line Question Option : No Option Orientation : Vertical
Correct Marks : 1 Wrong Marks : 0

The ON/OFF Controller with Hysteresis _____

Options :

1. Improves Accuracy
2. Increases chattering effect
3. Reduces Chattering effect
4. Improves speed of control action.

Question Number : 107 Question Id : 3909003827 Question Type : MCQ Option Shuffling : Yes Display Question Number : Yes
Single Line Question Option : No Option Orientation : Vertical
Correct Marks : 1 Wrong Marks : 0

T-S based fuzzy logic has _____

Options :

1. no rule base evaluation
2. no defuzzification
3. Fuzzification, rule base evaluation and defuzzification
4. no fuzzification

Question Number : 108 Question Id : 3909003828 Question Type : MCQ Option Shuffling : Yes Display Question Number : Yes
Single Line Question Option : No Option Orientation : Vertical
Correct Marks : 1 Wrong Marks : 0

The period of the function $f(t) = 100\cos\left(\frac{4\pi}{3}t + 21\right)$ is

Options :

1. $3/2$ sec
2. 2 sec

3. 4/3 sec

4. 3 sec

Question Number : 109 Question Id : 3909003829 Question Type : MCQ Option Shuffling : Yes Display Question Number : Yes
Single Line Question Option : No Option Orientation : Vertical
Correct Marks : 1 Wrong Marks : 0

Find the periodic convolution of $x(n) = \{1,2,3,4\}$ with $h(n) = \{1,2,1,-1\}$.

Options :

1. $\{10,5,4,11\}$

2. $\{1,5,7,11\}$

3. $\{1,4,3,-1\}$

4. $\{2,4,4,3\}$

Question Number : 110 Question Id : 3909003830 Question Type : MCQ Option Shuffling : Yes Display Question Number : Yes
Single Line Question Option : No Option Orientation : Vertical
Correct Marks : 1 Wrong Marks : 0

Z and Laplace transform are related by

Options :

1. $S = \ln Z$

2. $S = (\ln Z)/T$

3. $S = Z$

4. $S = T/(\ln Z)$

Question Number : 111 Question Id : 3909003831 Question Type : MCQ Option Shuffling : Yes Display Question Number : Yes
Single Line Question Option : No Option Orientation : Vertical
Correct Marks : 1 Wrong Marks : 0

A system can be completely described by a transfer function, if it is

Options :

1. Non-linear and Continuous
2. Linear and Time-varying
3. Non-linear and Time-invariant
4. Linear and Time-invariant

Question Number : 112 Question Id : 3909003832 Question Type : MCQ Option Shuffling : Yes Display Question Number : Yes
Single Line Question Option : No Option Orientation : Vertical
Correct Marks : 1 Wrong Marks : 0

The Instrumentation Amplifier has _____ Operational Amplifiers

Options :

1. Two
2. Three
3. One
4. Infinity

Question Number : 113 Question Id : 3909003833 Question Type : MCQ Option Shuffling : Yes Display Question Number : Yes
Single Line Question Option : No Option Orientation : Vertical
Correct Marks : 1 Wrong Marks : 0

The Hall Effect sensor the hall coefficient is $0.008 \text{ Vm}^3/\text{wbA}$ is subjected to magnetic flux density of $1 \text{ Wb}/\text{m}^2$. The thickness is 1 mm . When the current of 1 amps . Flow through the element, what is the voltage output?

Options :

1. 8 V
2. 4 V
3. 8 mV

4. 4 mV

Question Number : 114 Question Id : 3909003834 Question Type : MCQ Option Shuffling : Yes Display Question Number : Yes
Single Line Question Option : No Option Orientation : Vertical

Correct Marks : 1 Wrong Marks : 0

In the null type Wheatstone bridge, the Voltage source is connected between terminal A and C. The Resistance $R_{AB} = 2 R_{BC}$ and $R_{AD} = 10 \text{ K}\Omega$. Under Balanced bridge condition, The value of R_{CD} is

Options :

1. 10 k Ω

2. 15 k Ω

3. 5 k Ω

4. 20 k Ω

Question Number : 115 Question Id : 3909003835 Question Type : MCQ Option Shuffling : Yes Display Question Number : Yes
Single Line Question Option : No Option Orientation : Vertical

Correct Marks : 1 Wrong Marks : 0

The principle of air purge level measurement is based on

Options :

1. Hydro static

2. Magneto-strictive

3. Hydro pneumatic

4. Electro static

Question Number : 116 Question Id : 3909003836 Question Type : MCQ Option Shuffling : Yes Display Question Number : Yes
Single Line Question Option : No Option Orientation : Vertical

Correct Marks : 1 Wrong Marks : 0

In capacitive transducer, the relationship between change in capacitance with respect to change in distance is

Options :

1. Parabolic
2. direct
3. Square root
4. Inverse

Question Number : 117 Question Id : 3909003837 Question Type : MCQ Option Shuffling : Yes Display Question Number : Yes
Single Line Question Option : No Option Orientation : Vertical
Correct Marks : 1 Wrong Marks : 0

Thermocouple is connected in series is called

Options :

1. Thermo well
2. Thermopile
3. Thermistor
4. Thermostat

Question Number : 118 Question Id : 3909003838 Question Type : MCQ Option Shuffling : Yes Display Question Number : Yes
Single Line Question Option : No Option Orientation : Vertical
Correct Marks : 1 Wrong Marks : 0

Piezoelectric transducer is not suitable for the measurement of

Options :

1. Static displacement
2. Dynamic displacement
3. Pressure
4. Force

Question Number : 119 Question Id : 3909003839 Question Type : MCQ Option Shuffling : Yes Display Question Number : Yes
Single Line Question Option : No Option Orientation : Vertical

Correct Marks : 1 Wrong Marks : 0

K type thermocouple is made up of

Options :

1. Chormel-alumel
2. Platinum- Platinum- Rhodium
3. Iron Constantin
4. Copper Constantin

Question Number : 120 Question Id : 3909003840 Question Type : MCQ Option Shuffling : Yes Display Question Number : Yes
Single Line Question Option : No Option Orientation : Vertical

Correct Marks : 1 Wrong Marks : 0

In stepper motor with 10 degree per step rotates at 250 rpm. The required input pulse rate is _____ pulses per minute.

Options :

1. 9000
2. 150
3. 2500
4. 250