

Section 1

Instructions

For the following questions answer them individually

Question 1

Find the sum of the following series;

$$\frac{2}{1!} + \frac{3}{2!} + \frac{6}{3!} + \frac{11}{4!} + \frac{18}{5!} + \dots$$

- A $3e - 1$
- B $3(e - 1)$
- C $3(e + 1)$
- D $3e + 1$

Answer: B

Explanation:

$$\frac{2}{1!} + \frac{3}{2!} + \frac{6}{3!} + \frac{11}{4!} + \frac{18}{5!} + \dots = 2 + 1.5 + 1 + 0.5 + 0.15 + \text{smaller insignificant values} \approx 5.2$$

Option 'A' = $3e - 1 = 3 \times 2.718 - 1 = 7.15$ therefore cannot be our answer

Option 'B' = $3(e - 1) = 3 \times (2.718 - 1) = 5.154$ therefore can be our answer

Option 'C' = $3(e + 1) = 3 \times (2.718 + 1) = 11.15$ therefore cannot be our answer

Option 'D' = $3e + 1 = 9.15$ therefore cannot be our answer

Therefore option 'B' is our answer

Free Mock Test for IIFT

Question 2

How many positive integers 'n' can we form using the digits 3, 4, 4, 5, 6, 6, 7 if we want 'n' to exceed 6,000,000?

- A 320
- B 360
- C 540
- D 720

Answer: C

Explanation:

We are given exactly 7 digits - 3, 4, 4, 5, 6, 6, 7. The millions digit can be either 6 or 7.

Case 1: When the millions digit is 6.

6 _ _ _ _ _ We are left with six digits {3, 4, 4, 5, 6, 7}.

$$6!$$

These six digits can be arranged in six places in $6!$ ways.

Case 2: When the millions digit is 7.

7 _ _ _ _ _ We are left with six digits {3, 4, 4, 5, 6, 6}.

$$6!$$

These six digits can be arranged in six places in $2! \times 6!$ ways.

$$6! + 2! \times 6!$$

Therefore, total number of numbers 'n' = $6! + 2! \times 6! = 360 + 180 = 540$. Hence, option C is the correct answer.

Question 3

A Techno company has 14 machines of equal efficiency in its factory. The annual manufacturing costs are Rs. 42,000 and establishment charges are Rs. 12,000. The annual output of the company is Rs. 70,000. The annual output and manufacturing costs are directly proportional to the no. of machines. The shareholders get 12.5% of the total profit which is equal to the total output minus the total cost. If 7.14% of machines remain closed throughout the year, then the percentage decrease in the amount of profit of the shareholders would be:

- A 12%
- B 12.5%
- C 13.0%
- D None of these

Answer: B

Explanation:

Manufacturing cost (MC) of 14 machines = R.s. 42000

Output of 14 machines = Rs. 70000

Establishment cost (EC) = Rs. 12000

Profit = Rs.(70000 - 42000 - 12000) = Rs. 16000

Shareholder's profit = 12.5% of Rs. 16000 = Rs. 2000

It is given that 7.14% of the machines were non functional which means only 13 machines were functional.

MC of 13 machines = Rs. $(42000 * \frac{13}{14})$ = Rs. 39000 [As it is directly proportional to the number of functional machines]

Output of 13 machines = Rs. $(70000 * \frac{13}{14})$ = Rs. 65000 [As it is directly proportional to the number of functional machines]

EC of 13 machines = Rs. 12000 [As it does not depend on the number of functional machines]

Profit = Rs.(65000 - 39000 - 12000) = Rs. 14000

Shareholder's profit = 12.5% of Rs. 14000 = Rs. 1750

Reduction in Shareholder's profit = Rs.(2000 - 1750) = Rs. 250

Reduction % = $\frac{250}{2000} * 100\%$ = 12.5%

Hence, option B is the correct answer.

Question 4

Sun Life Insurance Company issues standard, preferred, and ultra-preferred policies. Among the company's policy holders of a certain age, 50% are standard with a probability of 0.01 of dying in the next year, 30% are preferred with a probability 0.008 of dying in the next year, and 20% are ultra-preferred with a probability of 0.007 of dying in the next year. If a policy holder of that age dies in the next year, what is the probability of the deceased being a preferred policy holder?

- A 0.1591
- B 0.2727
- C 0.375
- D None of these

Answer: B

Explanation:

If there are 10000 policy holders then 5000 are of standard, 3000 are of preferred and 2000 are of ultra-preferred

0.01 of standard policy holders may die next year i.e. 50 of standard policy holder may die next year

0.008 of preferred policy holders may die next year i.e. 24 of preferred policy holders may die next year

0.007 of ultra-preferred policy holders may die next year i.e. 14 of ultra-preferred policy holders may die next year

Total number of people that may die next year = 50+24+14 = 88

Probability that the person died is a preferred policy holder is $\frac{24}{88}$ = 0.2727

Therefore our answer is option 'B'

Download IIFT Previous Papers PDF

Question 5

A metro train from Mehrauli to Gurgaon has capacity to board 900 people. The fare charged (in RS.) is defined by the function $f = (54 - \frac{x}{32})^2$ where 'x' is the number of the people per trip. How many people per trip will make the marginal revenue equal to zero?

- A 1728
- B 576
- C 484
- D 364

Answer: B

Explanation:

It is given that the fare charged (in RS.) is defined by the function $f = (54 - \frac{x}{32})^2$ where 'x' is the number of the people per trip.

Let 'x' be the number of people per trip that will make the marginal revenue equal to zero.

Total revenue generated per trip, $g(x) = x * (54 - \frac{x}{32})^2$

When total revenue is maximum, then the marginal revenue will be zero. Therefore, we have to find out the value of 'x' for which $g'(x) = 0$

$$\rightarrow (54 - \frac{x}{32})^2 - 2 * (54 - \frac{x}{32}) * \frac{1}{32} = 0$$

$$\Rightarrow (54 - \frac{x}{32})^2 - 2 * (54 - \frac{x}{32}) * \frac{1}{32} = 0$$

$$\rightarrow (54 - \frac{x}{32}) * (54 - \frac{x}{32}) - 0$$

$$\Rightarrow x = 1728, 576$$

It is given that the train has a capacity of 900 only. Hence, $x \neq 1728$ i.e. $x = 576$. Therefore, option B is the correct answer.

Question 6

If each α, β and γ is a positive acute angle such that $\sin(\alpha + \beta - \gamma) = \frac{1}{\sqrt{2}}$, $\operatorname{Cosec}(\beta + \gamma - \alpha) = \sqrt{3}$ and $\tan(\gamma - \alpha - \beta) = \frac{1}{\sqrt{3}}$. What are the values of α, β, γ ?

- A $(37.5^\circ, 52.5^\circ, 45^\circ)$
- B $(37^\circ, 53^\circ, 45^\circ)$
- C $(45^\circ, 37.5^\circ, 52.5^\circ)$
- D $(34.5^\circ, 55.5^\circ, 45^\circ)$

Answer: A

Explanation:

$$\text{if } \sin(\alpha + \beta - \gamma) = \frac{1}{\sqrt{2}} \text{ then } \alpha + \beta - \gamma = 45^\circ \dots(1)$$

$$\text{if } \operatorname{Cosec}(\beta + \gamma - \alpha) = \sqrt{3} \text{ then } \beta + \gamma - \alpha = 60^\circ \dots(2)$$

$$\text{if } \tan(\gamma - \alpha - \beta) = \frac{1}{\sqrt{3}} \text{ then } \gamma - \alpha - \beta = 30^\circ \dots(3)$$

$$\text{Adding we get } \alpha + \beta + \gamma = 135^\circ \dots(4)$$

from 1,2,3 and 4 we get $\alpha = 37.5^\circ$ therefore answer is option 'A'

Question 7

Shyam, Gopal and Madhur are three partners in a business. Their capitals are respectively Rs 4000, Rs 8000 and Rs 6000. Shyam gets 20% of total profit for managing the business. The remaining profit is divided among the three in the ratio of their capitals. At the end of the year, the profit of Shyam is Rs 2200 less than the sum of the profit of Gopal and Madhur. How much profit, Madhur will get?

- A Rs.1600
- B Rs.2400
- C Rs.3000
- D Rs.5000

Answer: B

Explanation:

Let the total profit be P. Shyam will get 0.2P for managing the business rest 0.8 P will be divided in the ratio of 2:4:3

i.e. shyam will get $0.2P + 0.8P \times \frac{2}{9}$ and Gopal and Madhur will together get $0.8P \times \frac{7}{9}$

Given that $0.8P \times \frac{7}{9} - (0.2P + 0.8P \times \frac{2}{9}) = 2200$

Solving we get $P = 9000$ therefore profit madhur will get is $0.8 \times 9000 \times \frac{1}{3} = 2400$

Therefore our answer is option 'B'

Download IIFT GK PDFs

Question 8

In how many ways can four letters of the word 'SERIES' be arranged?

- A 24
- B 42
- C 84
- D 102

Answer: D

Explanation:

We can see that letters are S, S, E, E, I, R.

Case 1: When all 4 letters are different. There is only one way where we select one each S, E, I, R.

Total number of 4 letter words which can be formed using these letters = $4! = 24$.

Case 2: When all 2 letters are of 1 type and 2 letters are different.

Total number of ways in which 4 letter can be chosen = $2C1 \times 3C2 = 6$

$4!$

Total number of 4 letter words which can be formed using these letters = $6 \times 2! = 72$

Case 3: When all 2 letters are of 1 type and remaining 2 letters are of different another same type. There is only one way when we select S, S, E, E.

$4!$

Total number of 4 letter words which can be formed using these letters = $2! \times 2! = 6$

We have considered all possible cases. Hence, total number of four letters of the word can be made = $24 + 72 + 6 = 102$. Hence, option D is the correct answer.

Question 9

The area of a triangle is 6, two of its vertices are (1, 1) and (4, -1), the third vertex lies on $y = x + 5$. Find the third vertex.

A $(\frac{2}{5}, \frac{27}{5})$

B $(-\frac{3}{5}, \frac{22}{5})$

C $(\frac{3}{5}, \frac{28}{5})$

D None of these

Answer: A

Explanation:

Let us assume that X co-ordinate of the 3rd vertex is a. Then $y = a + 5$. So the co-ordinates of the vertex = (a, a+5)

Therefore, $6 = \frac{1}{2} \times \begin{vmatrix} 1 & 1 & 1 \\ 1 & 4 & a \\ a & a+5 & 5 \end{vmatrix}$

$\rightarrow \pm 12 = 1(-1-a-5) - 1(4 - a) + 1(4a+20+a)$
 $\rightarrow \pm 12 = 5a + 10$
 $\Rightarrow a = \frac{2}{5}, \frac{27}{5}$

Hence, the third vertex can be out of the two values $(\frac{2}{5}, \frac{27}{5})$ or $(\frac{27}{5}, \frac{2}{5})$.

Therefore, option A is the correct answer.

Question 10

A small confectioner bought a certain number of pastries flavoured pineapple, mango and black-forest from the bakery, giving for each pastry as many rupees as there were pastry of that kind;altogether he bought 23 pastries and spent Rs.211; find the number of each kind of pastry that he bought, if mango pastry are cheaper than pineapple pastry and dearer than black-forest pastry.

A (10, 9, 4)

B (11, 9, 3)

C (10, 8, 5)

D (11, 8, 4)

Answer: B

Explanation:

Given that cost of a type of pastry is equal to the quantity bought

if x,y,z are the no. of pastries bought of each type then $x^2 + y^2 + z^2 = 211$ and $x+y+z = 23$

Using options,

option A = 10,9,4 i.e. $100+81+16 = 197$ therefore cannot be the answer

option B= 11, 9, 3 i.e. $121+81+9 = 211$ Therefore is our answer

option C = 10, 8, 5 i.e. $100+64+25 = 189$ therefore cannot be the answer

option D = 11, 8, 4 i.e. $121+64+16 = 201$ therefore cannot be the answer

Therefore our answer is option 'B'

Question 11

Find the root of the quadratic equation $bx^2 - 2ax + a = 0$

A $\frac{\sqrt{b}}{\sqrt{b} - \sqrt{a-b}}$

B $\frac{\sqrt{a}}{\sqrt{b} - \sqrt{a-b}}$

C $\frac{\sqrt{a}}{\sqrt{a} - \sqrt{a-b}}$

D $\frac{\sqrt{a}}{\sqrt{a} + \sqrt{a-b}}$

Answer: C

Explanation:

If the quadratic equation is of type $Ax^2 + Bx + C = 0$ then the roots of the quadratic equation are given by

$$x = \frac{-B \pm \sqrt{B^2 - 4AC}}{2A}$$

Comparing $Ax^2 + Bx + C = 0$ with $bx^2 - 2ax + a = 0$, $A = b$, $B = -2a$, $C = a$

$$2a = \sqrt{4a^2 - 4ba}$$

Hence, the roots = $\frac{2a \pm \sqrt{4a^2 - 4ba}}{2b}$

$$x = \frac{a \pm \sqrt{a^2 - ba}}{b}$$

Let $x_1 = \frac{a - \sqrt{a^2 - ba}}{b}$, $x_2 = \frac{a + \sqrt{a^2 - ba}}{b}$

Rationalizing $x_1 = \frac{a - \sqrt{a^2 - ba}}{b}$

$$\Rightarrow x_1 = \frac{a - \sqrt{a^2 - ba}}{b} \times \frac{a + \sqrt{a^2 - ba}}{a + \sqrt{a^2 - ba}}$$

$$\rightarrow x_1 = \frac{a^2 - (a^2 - ba)}{b(a + \sqrt{a^2 - ba})}$$

$$\Rightarrow x_1 = \frac{ab}{b(a + \sqrt{a^2 - ba})}$$

$$\Rightarrow x_1 = \frac{a}{a + \sqrt{a^2 - ba}}$$

$$\Rightarrow x_1 = \frac{a}{a + \sqrt{a} \times \sqrt{a-b}}$$

$$\rightarrow x_1 = \frac{\sqrt{a}}{\sqrt{a} + \sqrt{a-b}}$$

Similarly, $x_2 = \frac{\sqrt{a}}{\sqrt{a} - \sqrt{a-b}}$

Therefore, $x = \frac{\sqrt{a}}{\sqrt{a} \pm \sqrt{a-b}}$. Hence, option C is the correct answer.

Question 12

Three Professors Dr. Gupta, Dr. Sharma and Dr. Singh are evaluating answer scripts of a subject. Dr. Gupta is 40% more efficient than Dr. Sharma, who is 20% more efficient than Dr. Singh. Dr. Gupta takes 10 days less than Dr. Sharma to complete the evaluation work. Dr. Gupta starts the evaluation work and works for 10 days and then Dr. Sharma takes over. Dr. Sharma evaluates for next 15 days and then stops. In how many days, Dr. Singh can complete the remaining evaluation work.

- A 7.2 days
- B 9.5 days
- C 11.5 days
- D None of these

Answer: A

Explanation:

let G be number of days in which Dr. gupta can complete the evaluation of answer sheet , let Sh be number of days in which Dr. Sharma can complete the evaluation of answer sheet , let Si be number of days in which Dr. Singh can complete the evaluation of answer sheet

Given Dr. Gupta is 40% more efficient than Dr. Sharma therefore number of days required by Dr. Sharma to complete the evaluation of answer sheet = $1.4 \times G$

Dr. Gupta takes 10 days less than Dr. Sharma to complete the evaluation work i.e. $1.4G - G = 10$ therefore $G = 25$ and hence $Sh = 35$

Also given that Dr. Sharma is 20% more efficient than Dr. Singh therefore number of days required by Dr. Singh to complete the evaluation of answer sheet = $\frac{35}{1.2} = 42$ i.e. $Si = 42$

Dr. Gupta starts the evaluation work and works for 10 days therefore he completes $\frac{10}{25}$ of work then Dr. Sharma takes over. Dr. Sharma evaluates for next 15 days therefore he completes $\frac{15}{35}$ of work. Fraction of work left is $1 - \frac{10}{25} - \frac{15}{35} = \frac{6}{35}$ now time required by Dr. Singh to complete this amount of work is $\frac{6 \times 42}{35} = 7.2$ days

Therefore our answer is option 'A'

Question 13

If $[x]$ is the greater integer less than or equal to 'x', then find the value of the following series $[\sqrt{1}] + [\sqrt{2}] + [\sqrt{3}] + [\sqrt{4}] + \dots + [\sqrt{360}]$

- A 4389
- B 4839
- C 3498
- D 3489

Answer: A

Explanation:

$[\sqrt{1}] + [\sqrt{2}] + [\sqrt{3}] + [\sqrt{4}] + \dots + [\sqrt{360}] = 1 + 1 + 1 + 2 + 2 + 2 + 2 + 2 + 2 + 3 + 3 + 3 \dots 7 \text{ times} + 4 + 4 + \dots 9 \text{ times} + \dots + 18 + 18 + \dots 37 \text{ times}$

$$= 1 \times 3 + 2 \times 5 + 3 \times 7 + 4 \times 9 + \dots + 18 \times 37$$

$$= \sum_{n=1}^{18} n(2n+1)$$

$$= \sum_{n=1}^{18} 2n^2 + n$$

$$= \frac{2n \times (n-1) \times (2n-1)}{6} + \frac{n \times (n-1)}{2}$$

$$= \frac{2 \times 18 \times (19) \times (37)}{6} + \frac{18 \times 19}{2}$$

$$= 4389$$

Therefore our answer is option 'A'



Top 500+ Free Questions for IIFT

Question 14

What is the value of $\sqrt{\frac{a}{b}}$, if $\log_4 \log_4 4^{a-b} = 2 \log_4(\sqrt{a} - \sqrt{b}) + 1$

- A -5/3
- B 2
- C 5/3
- D 1

Answer: C

Explanation:

$\sqrt{\frac{a}{b}}$, if $\log_4 \log_4 4^{a-b} = 2 \log_4(\sqrt{a} - \sqrt{b}) + \log_4 4$

i.e. $\log_4 \log_4 4^{a-b} = \log_4((\sqrt{a} - \sqrt{b})^2) * 4$

i.e. $\log_4 4^{a-b} = ((\sqrt{a} - \sqrt{b})^2) * 4$

i.e. $(a-b) * \log_4 4 = ((\sqrt{a} - \sqrt{b})^2) * 4$

i.e. $a-b = 4a+4b-8\sqrt{ab}$

i.e. $3a + 5b - 8\sqrt{ab} = 0$

i.e. $3\sqrt{\frac{a}{b}}^2 - 8\sqrt{\frac{a}{b}} + 5 = 0$

put $\sqrt{\frac{a}{b}} = t$

therefore $3t^2 - 8t + 5 = 0$

solving we get $t = 1$ or $t = \frac{5}{3}$

i.e. $\sqrt{\frac{a}{b}} = 1$ or $\frac{5}{3}$

but if $\sqrt{\frac{a}{b}} = 1$ then $a=b$ then $\log_4(\sqrt{a} - \sqrt{b})$ will become indefinite

Therefore $\sqrt{\frac{a}{b}} = \frac{5}{3}$

Therefore our answer is option 'C'

Question 15

Three pipes A, B and C are connected to a tank. These pipes can fill the tank separately in 5 hours, 10 hours and 15 hours respectively. When all the three pipes were opened simultaneously, it was observed that pipes A and B were supplying water at 3/4th of their normal rates for the first hour after which they supplied water at the normal rate. Pipe C supplied water at 2/3rd of its normal rate for first 2 hours, after which it supplied at its normal rate. In how much time, tank would be filled.

- A 1.05 Hours
- B 2.05 Hours
- C 3.05 Hours
- D None of these

Answer: C

Explanation:

Let the capacity of the tank be 60 litres.

Capacity of the first pipe = 12 l/hr

Capacity of the second pipe = 6 l/hr

Capacity of the third pipe = 4 l/hr

In 2 hrs, first pipe fills $(9 + 12) \text{ l} = 21 \text{ l}$
 In 2 hrs, second pipe fills $(4.5 + 6) = 10.5 \text{ l}$
 In 2 hrs, third pipe fills $(16/3) \text{ l}$
 In 2 hrs, tank filled = $(21 + 10.5 + 5.33) \text{ l} = 36.83 \text{ l}$
 Tank left to be filled = $(60 - 36.83) \text{ l} = 23.17 \text{ l}$
 Time required = $(23.17/22) \text{ hr} = 1.05 \text{ hrs}$
 Total time = 3.05 hrs
 Hence, option C is the correct answer.

Question 16

The minimum value of $3^{\sin x} + 3^{\cos x}$ is

- A 2
- B $2(3^{\frac{1}{\sqrt{2}}})$
- C $3^{1-\frac{1}{\sqrt{2}}}$
- D None of these

Answer: B

Explanation:

Using $AM \geq GM$, We can say that

$$\frac{3^{\sin x} + 3^{\cos x}}{2} \geq \sqrt{3^{\sin x} * 3^{\cos x}}$$

$$\rightarrow 3^{\sin x} + 3^{\cos x} \geq 2 * 3^{\frac{\sin x + \cos x}{2}} \dots (1)$$

We know that $-\sqrt{A^2 + B^2} \leq A \sin x + B \cos x \leq \sqrt{A^2 + B^2}$

$$\text{Therefore, } -\sqrt{1^2 + 1^2} \leq \sin x + \cos x \leq \sqrt{1^2 + 1^2}$$

$$\rightarrow -\sqrt{2} \leq \sin x + \cos x \leq \sqrt{2}$$

Hence, we can say that the minimum value of $\sin x + \cos x = -\sqrt{2} \dots (2)$

From equation (1) and (2) we can say that,

$$\Rightarrow 3^{\sin x} + 3^{\cos x} \geq 2 * 3^{\frac{-\sqrt{2}}{2}}$$

$$\rightarrow 3^{\sin x} + 3^{\cos x} \geq 2 * 3^{\frac{1}{\sqrt{2}}}$$

Therefore, option B is the correct answer.

Download IIFT Syllabus PDF

Question 17

In a B-School there are three levels of faculty positions i.e. Professor, Associate Professor and Assistant Professor. It is found that the sum of the ages of all faculty present is 2160, their average age is 36; the average age of the Professor and Associate Professor is 39; of the Associate Professor and Assistant Professor is $32\frac{8}{11}$; of the Professor and Assistant Professor is $36\frac{2}{3}$; Had each professor been 1 year older, each Associate Professor 6 years older, and each Assistant Professor 7 years older, then their average age would increase by 5 years. What will be the number of faculty at each level and their average ages?

- A (16, 24, 20 : 45, 35, 30 years)
- B (18, 24, 20 : 42, 38, 30 years)
- C (16, 20, 24 : 50, 30, 30 years)
- D None of these

A $\frac{16}{2\sqrt{2}}; \frac{4(1+\sqrt{2})}{3+2\sqrt{2}}$

B $\frac{8}{2\sqrt{2}}; \frac{2(1+\sqrt{2})}{3+2\sqrt{2}}$

C $\frac{16}{1\sqrt{2}}; \frac{3(1+\sqrt{2})}{3+2\sqrt{2}}$

D None of these

Answer: D

Explanation:

Let us assume that 'a' is the length of the side of equal sides of the isosceles triangle.

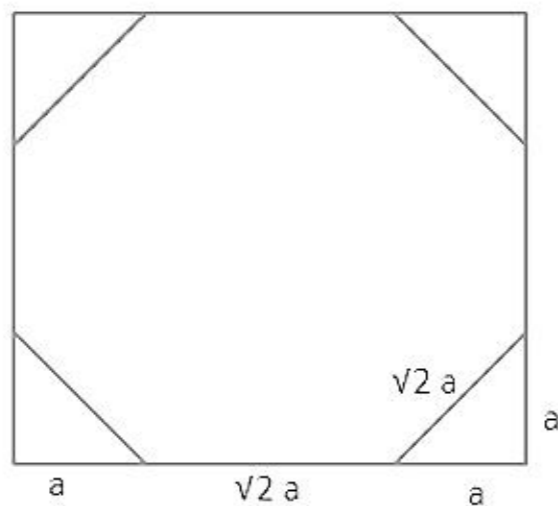

We can see that $a + \sqrt{2} * a + a = 2a$

$\rightarrow a = 2 / \sqrt{2}$

Therefore, the perimeter of the regular octagon = $8 * a * \sqrt{2}$

$8\sqrt{2} * 2 / \sqrt{2}$

$\rightarrow 16$

Area of regular octagon = $2x^2(1 + \sqrt{2})$ where 'x' is the length of each side.

Here, $x = a\sqrt{2} = 2 / \sqrt{2} = 1 / \sqrt{2}$

Therefore, area of the regular octagon = $2 * (1 / \sqrt{2})^2(1 + \sqrt{2}) = 1 + \sqrt{2} = 1 / \sqrt{2} * 1 / \sqrt{2} = 3 + 2\sqrt{2}$

Hence, we can say that none of the given answer is correct.

Quant Formulas for IIFT PDF

Question 20

The smallest perfect square that is divisible by 7!

A 44100

B 176400

C 705600

D 19600

Answer: B

Explanation:

7! can be broken into prime factors.

$$7! = 1 \times 2 \times 3 \times 4 \times 5 \times 6 \times 7 = 2^4 \times 3^2 \times 5 \times 7$$

Hence, the smallest perfect square which is divisible by 7! will $2^4 \times 3^2 \times 5^2 \times 7^2 = 5040 \times 5 \times 7 = 176400$

Question 21

A survey shows that 61%, 46% and 29% of the people watched "3 Idiots", "Rajneeti" and "Avatar" respectively. 25% people watched exactly two of the three movies and 3% watched none. What percentage of people watched all the three movies?

A 39%

B 11%

C 14%

D 7%

Answer: D

Explanation:

Let the number of people who watched exactly one movie be 'a', the number of people who watched exactly two movies be 'b' and the number of people who watched exactly three movies be 'c'

$$\text{Then, } a + b + c = 100 - 3 = 97 \dots\dots\dots(i)$$

$$\text{also, } a + 2b + 3c = 61 + 46 + 29 = 136 \dots\dots\dots(ii)$$

On subtracting (i) from (ii), we get

$$b + 2c = 39$$

It is given that, $b = 25$

$$\text{So, } c = 7$$

Therefore, 7% people watched all the three movies.

Hence, option D is the correct answer.

Question 22

In a triangle ABC the length of side BC is 295. If the length of side AB is a perfect square, then the length of side AC is a power of 2, and the length of side AC is twice the length of side AB. Determine the perimeter of the triangle.

A 343

B 487

C 1063

D None of these

Answer: C

Explanation:

$$\text{Let } AC = 2^k$$

$$AC = 2 * AB$$

$$\text{So, } AB = 2^{k-1}$$

Only 256 and 512 satisfy this condition as the third side is 295 and we have to ensure that sum of the two sides of the triangle is greater than the third side.

$$\text{Thus, the perimeter} = (256 + 512 + 295) = 1063.$$

Hence, option C is the correct answer.

IIFT Free Preparation App

Question 23

In a Green view apartment, the houses of a row are numbered consecutively from 1 to 49. Assuming that there is a value of 'x' such that the sum of the numbers of the houses preceding the house numbered 'x' is equal to the sum of the numbers of the houses following it. Then what will be the value of 'x'?

- A 21
- B 30
- C 35
- D 42

Answer: C

Explanation:

It is given that sum of the first $(x - 1)$ numbers is equal to sum of the numbers from $(x + 1)$ to 49

or, sum of $(x - 1)$ numbers = sum of first 49 numbers - sum of first x numbers

$$\frac{x(x-1)}{2} = \frac{49 \times 50}{2} - \frac{x(x+1)}{2}$$

On solving, we get $x = 35$

Hence, option C is the correct answer.

Question 24

To start a new enterprise, Mr. Yogesh has borrowed a total of Rs. 60,000 from two money lenders with the interest being compounded annually, to be repaid at the end of two years. Mr. Yogesh repaid Rs.38, 800 more to the first money lender compared to the second money lender at the end of two years. The first money lender charged an interest rate, which was 10% more than what was charged by the second money lender. If Mr. Yogesh had instead borrowed Rs. 30,000 from each at their respective initial rates for two years, he would have paid Rs.7, 500 more to the first money lender compared to the second. Then money borrowed by Mr. Yogesh from first money lender is?

- A 20,000
- B 35,000
- C 40,000
- D 42,000

Answer: C

Explanation:

Let the interest on the second part be $r\%$

Then, the rate on the first part = $(r + 10)\%$ It is given that,

$$30000\left(1 + \frac{r+10}{100}\right)^2 - 30000\left(1 + \frac{r}{100}\right)^2 = 7500$$

On solving, we get $r = 20\%$

Let the first part be Rs. a

Then, the second part = Rs. $(60000 - a)$

$$a\left(1 + \frac{30}{100}\right)^2 - (60000 - a)\left(1 + \frac{20}{100}\right)^2 = 38800$$

On solving, we get $a = \text{Rs. } 40000$

Hence, option C is the correct answer.

Question 25

Find the coefficient of x^{12} in the expansion of $(1 - x^6)^4(1 - x)^{-4}$

A 113

B 119

C 125

D 132

Answer: C

Explanation:

We can write $(1 - x^6)^4 = {}^4C_0(1)^4(x^6)^0 - {}^4C_1(1)^3(x^6)^1 + {}^4C_2(1)^2(x^6)^2 - {}^4C_3(1)^1(x^6)^3 + {}^4C_4(1)^0(x^6)^4$
 $\Rightarrow (1 - x^6)^4 = (1 - 4x^6 + 6x^{12} - 4x^{18} + x^{24})$

Therefore, we can say

$$(1 - x^6)^4(1 - x)^{-4} = (1 - 4x^6 - 6x^{12} - 4x^{18} - x^{24}) * (1 - x)^{-4}$$

We have to find out coefficient of x^{12}, x^6, x^0 in $(1 - x)^{-4}$.

We can use binomial expansion for negative coefficients. Therefore, coefficient of x^{12} in $(1 - x)^{-4}$

$$\Rightarrow \frac{(-4) * (-4 - 1) * (-4 - 2) * \dots * (-4 - 11)}{12!}$$

$$\Rightarrow \frac{15!}{12! * 3!}$$

$$\Rightarrow \frac{15 * 14 * 13}{3 * 2 * 1}$$

$$\Rightarrow 455$$

Similarly, coefficient of x^6 in $(1 - x)^{-4}$

$$\Rightarrow \frac{(-4) * (-4 - 1) * (-4 - 2) * \dots * (-4 - 5)}{6!}$$

$$\Rightarrow \frac{9!}{6! * 3!}$$

$$\Rightarrow \frac{7 * 8 * 9}{3 * 2 * 1}$$

$$\Rightarrow 84$$

Coefficient of x^0 in $(1 - x)^{-4}$ is 1.

Therefore, we can say that the coefficient of x^{12} in the expansion of $(1 - x^6)^4(1 - x)^{-4} = 455 + (-4 * 84) + (1 * 6) = 125$. Hence, option C is the correct answer.

Alternative Solution:

$$(1 - x^6)^4 = (1 - x)^4(1 + x + x^2 + x^3 + x^4 + x^5)^4$$
$$\Rightarrow (1 - x^6)^4(1 - x)^{-4} = (1 - x - x^2 - x^3 + x^4 + x^5)^4$$

Hence we need to find coeff of x^{12} in $(1 + x + x^2 + x^3 + x^4 + x^5)^4$
 $= (1 + x + x^2 + x^3 + x^4 + x^5) \times (1 + x + x^2 + x^3 + x^4 + x^5) \times (1 + x + x^2 + x^3 + x^4 + x^5) \times (1 + x + x^2 + x^3 + x^4 + x^5)$

This will be equal to number of integral solutions for $a + b + c + d = 12, 0 \leq a, b, c, d \leq 4$

a is the power of x from the first expression, b is the power of x

Lets find the set of values for (a,b,c,d)

$$(5,5,2,0) \Rightarrow \text{Number of ways of arranging} = \frac{4!}{2!} = 12$$

$$(5,5,1,1) \Rightarrow \text{Number of ways of arranging} = \frac{4!}{(2! * 2!)} = 6$$

$$(5,4,3,0) \Rightarrow \text{Number of ways of arranging} = 4! = 24$$

- (5,4,2,1) => Number of ways of arranging = $4! = 24$
- (5,3,2,2) => Number of ways of arranging = $4!/2! = 12$
- (5,3,3,1) => Number of ways of arranging = $4!/2! = 12$
- (4,4,4,0) => Number of ways of arranging = $4!/3! = 4$
- (4,4,3,1) => Number of ways of arranging = $4!/2! = 12$
- (4,4,2,2) => Number of ways of arranging = $4!/(2!*2!) = 6$
- (4,3,3,2) => Number of ways of arranging = $4!/2! = 12$
- (3,3,3,3) => Number of ways of arranging = $4!/4! = 1$

Hence the coeff of $x^{12} = 24*2 + 12*5 + 6*2 + 4 + 1 = 125$

Download General Science Notes for IIFT PDF

Question 26

Mukesh, Suresh and Dinesh travel from Delhi to Mathura to attend Janmashmi Utsav. They have a bike which can carry only two riders at a time as per traffic rules. Bike can be driven only by Mukesh. Mathura is 300Km from Delhi. All of them can walk at 15Km/Hrs. All of them start their journey from Delhi simultaneously and are required to reach Mathura at the same time. If the speed of bike is 60Km/Hrs then what is the shortest possible time in which all three can reach Mathura at the same time.

- A $8\frac{2}{7}$ Hrs
- B $9\frac{2}{7}$ Hrs
- C 10 Hrs
- D None of these

Answer: B

Explanation:

Let us assume that Mukesh and Suresh started on bike from Delhi to Mathura and Dinesh started walking at the same time. Mukesh drops Suresh in a mid-way such that Suresh will take same time to reach Mathura with Mukesh and Dinesh. In the same time Mukesh will turn back and will pick up Dinesh.

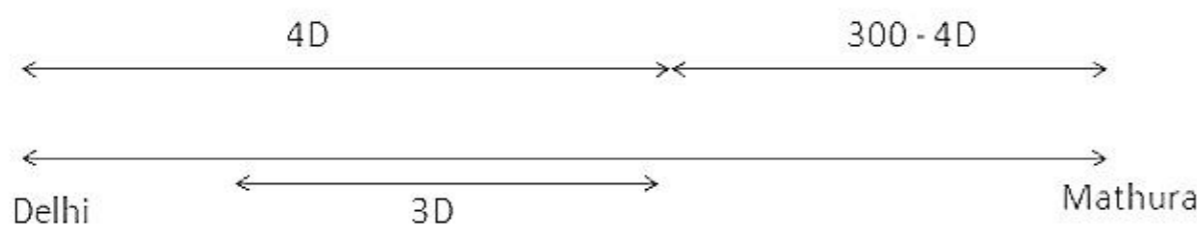

Let us assume that '4D' is the distance covered by Mukesh and Suresh. Then Suresh must have covered remaining 300 - 4D kms by walking at 15 km/hr. When Mukesh dropped Suresh by that time Dinesh have already covered D kms and now Mukesh and Dinesh and would have 3D kms apart. Since Mukesh is 4 times faster than Dinesh, Mukesh would have covered (4/5) of 3D kms.

In addition to this, Mukesh and Dinesh have to cover 2.4D+300-4D kms to reach Mathura at 60 km/hr.

By equating the time taken by Mukesh and Suresh to reach Mathura after the point when Mukesh dropped Suresh,

$$\frac{300-4D}{15} = \frac{2.4D+2.4D+300-4D}{60}$$

$$\Rightarrow 16.8 * D = 900$$

$$\Rightarrow D = \frac{375}{7} \text{ kms}$$

Therefore, minimum time taken by them to finish the journey = $\frac{4D}{60} + \frac{300-4D}{15}$

$$\Rightarrow 20 - \frac{D}{5}$$

$$\Rightarrow 20 - \frac{375}{7 * 5}$$

$$\Rightarrow 20 - \frac{75}{7}$$

$\Rightarrow \frac{65}{7}$ or $9\frac{2}{7}$ hours. Hence, option B is the correct answer.

Question 27

In a rocket shape firecracker, explosive powder is to be filled up inside the metallic enclosure. The metallic enclosure is made up of a cylindrical base and conical top with the base of radius 8 centimeter. The ratio of height of cylinder and cone is 5:3. A cylindrical hole is drilled through the metal solid with height one third the height of the metal solid. What should be the radius of the hole, so that volume of the hole (in which gun powder is to be filled up) is half of the volume of metal solid after drilling?

- A $4\sqrt{3}$ cm
- B 4.0cm
- C 3.0cm
- D None of these

Answer: A

Explanation:

Let us draw an appropriate diagram. Let us assume that 'R' is the radius of the hole.

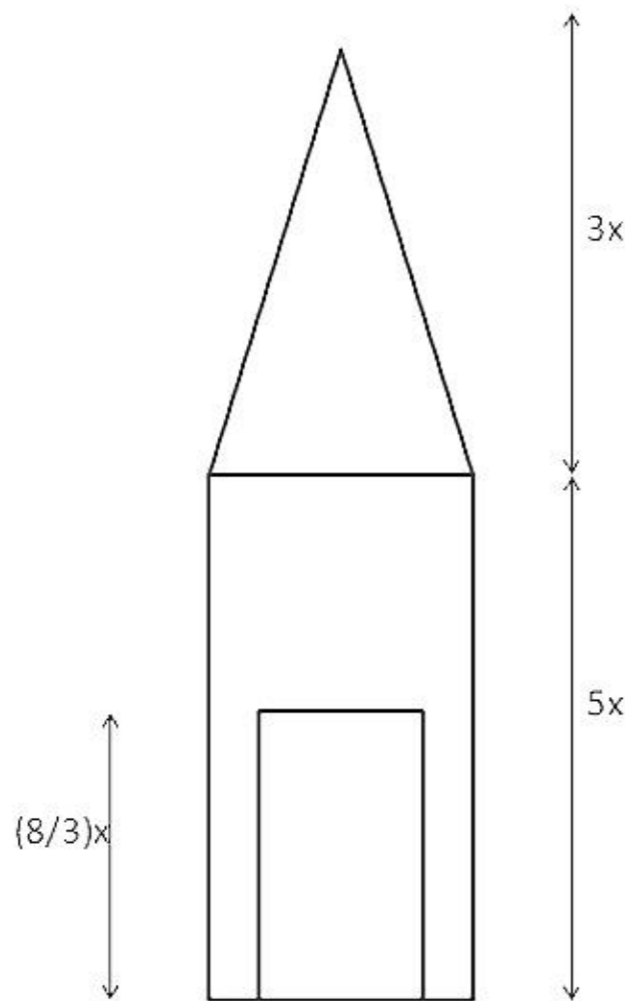

$$\frac{1}{2} * (\text{Total volume} - \text{Volume of the hole}) = \text{Volume of the hole}$$

$$\text{Volume of the hole} = \frac{1}{3} * \text{Total volume of the rocket}$$

$$\pi * R^2 * \frac{8}{3} * x = \frac{1}{3} * (\pi * 8^2 * 5x + \frac{1}{3} * \pi * 8^2 * 3x)$$

$$R^2 * \frac{8}{3} = \frac{1}{3} * (8^2 * 5 + \frac{1}{3} * 8^2 * 3)$$

$$R^2 = 48$$

$$R = 4\sqrt{3}$$
 cm. Hence, option A is the correct answer.

Question 28

A small and medium enterprise imports two components A and B from Taiwan and China respectively and assembles them with other components to form a toy. Component A contributes to 10% of production cost. Component B contributes to 20% of the production cost. Usually the company sells this toy at 20% above the production cost. Due to increase in the raw material and labour cost in both the countries, component A became 20% costlier and component B became 40% costlier. Owing to these reasons the company increased its selling price by 15%. Considering that cost of other components does not change, what will be the profit percentage, if the toy is sold at the new price?

- A 15.5%

B 25.5%

C 35.5%

D 40%

Answer: B

Explanation:

Let the production cost be Rs. 100

The, Selling Price = Rs. 120

Price of component A = Rs. 10

Price of component B = Rs. 20

Price of other components = Rs. $(100 - 10 - 20) = \text{Rs. } 70$

After increase in prices,

Price of component A = Rs. 12

Price of component B = Rs. 28

Price of other components = Rs. 70

Total Cost of production = Rs. $(12 + 28 + 70) = \text{Rs. } 110$

Selling price = Rs. $(1.15 * 120) = \text{Rs. } 138$

Profit = Rs. 28

Profit % = 25.45%

Hence, option B is the correct answer.

Take 3 Free CAT Mocks (With Solutions)

Question 29

What is the value of c^2 in the given figure, where the radius of the circle is 'a' unit.

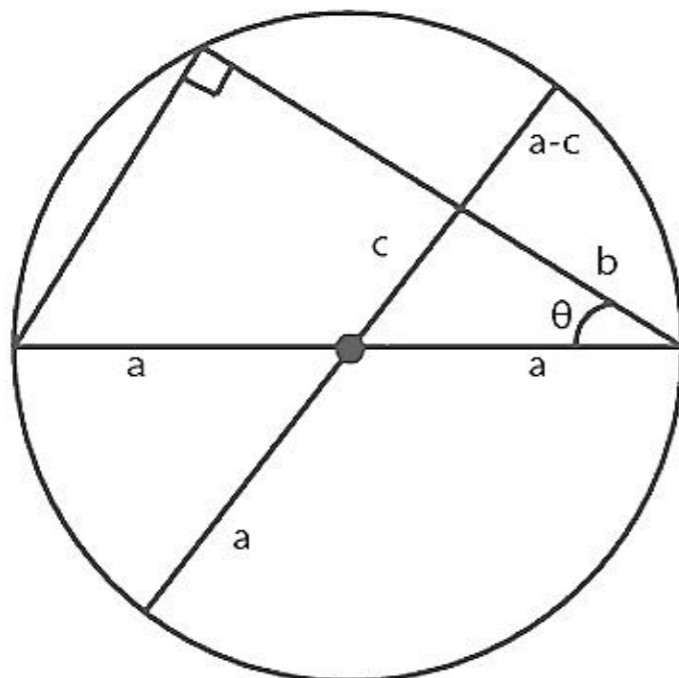

A $c^2 = a^2 + b^2 - 2ab \cos \theta$

B $c^2 = a^2 + b^2 - 2ab \sin \theta$

C $c^2 = a^2 - b^2 + 2ab \cos \theta$

D None of these

Answer: A

Explanation:

Applying the cosine rule, we get $c^2 = a^2 + b^2 - 2ab \cos \theta$

Hence, option A is the correct answer.

Question 30

How many subsets of $\{1, 2, 3 \dots 11\}$ contain at least one even integer?

- A 1900
- B 1964
- C 1984
- D 2048

Answer: C

Explanation:

Total number of subsets that can be formed with the left of 11 elements = $2^{11} = 2048$

The number of subsets which contain only odd numbers $\{1, 3, 5, 7, 9, 11\} = 2^6 = 64$

Number of subsets which contain at least one even integer = Total number of subsets - the number of subsets which contain only odd numbers

$\Rightarrow 2048 - 64 = 1984$. Hence, option C is the correct answer.

XAT Previous Papers

Section 2

Instructions

Read the following information and choose the right alternative in the questions that follow.

During the cultural week of an institute six competitions were conducted. The cultural week was inaugurated in the morning of 19th October, Wednesday and continued till 26th October. In the span of 8 days six competitions namely debate, folk dance, fash-p, street play, rock band, and group song, were organized along with various other cultural programs. The information available from the institute is:

- i. Only one competition was held in a day
- ii. Rock band competition was not conducted on the closing day.
- iii. Fash-p was conducted on the day prior to debate competition
- iv. Group song competition was conducted neither on Wednesday nor on Saturday
- v. None of the competition was conducted on Thursday and Sunday
- vi. Street Play competition was held on Monday
- vii. There was gap of two days between debate competition and group song competition

Question 31

The cultural week started with which competition?

- A Fash-p competition
- B Debate competition
- C Street play competition
- D Rock band competition

Answer: D

Explanation:

Let us draw a table consisting the day and competition.

Day	Competition
19th Oct, Wednesday	
20th Oct, Thursday	
21st Oct, Friday	
22nd Oct, Saturday	
23rd Oct, Sunday	
24th Oct, Monday	
25th Oct, Tuesday	
26th Oct, Wednesday	

In statement 5, it is given that none of the competition was conducted on Thursday and Sunday. Also, Street Play competition was held on Monday.

Day	Competition
19th Oct, Wednesday	
20th Oct, Thursday	None
21st Oct, Friday	
22nd Oct, Saturday	
23rd Oct, Sunday	None
24th Oct, Monday	Street Play
25th Oct, Tuesday	
26th Oct, Wednesday	

It is given that Group Song competition was conducted neither on Wednesday nor on Saturday. Hence, the Group Song competition can take place on either Tuesday or Friday. We are also given that there was gap of two days between Debate competition and Group Song competition.

If the Group Song competition is on Friday, then Debate competition should take place in 24th Oct, Monday but that slot is already filled. Hence, this case is not possible. Therefore, we can say that Group Song competition was on Tuesday. Consecutively, we can say that the Debate competition was on Saturday.

Day	Competition
19th Oct, Wednesday	
20th Oct, Thursday	None
21st Oct, Friday	
22nd Oct, Saturday	Debate
23rd Oct, Sunday	None
24th Oct, Monday	Street Play
25th Oct, Tuesday	Group Song
26th Oct, Wednesday	

Rock band competition was not conducted on the closing day. Hence, we can say that Rock Band competition took place on either 19th Oct or 21st Oct.

It is also given that Fash-p was conducted on the day prior to debate competition. Hence, we can say that Fash-P was conducted on 21st Oct Friday. Consequently, we can say that Rock Band competition took place on 19th Oct Wednesday.

Also, we can say that folk dance competition held on 26th Oct.

Day	Competition
19th Oct, Wednesday	Rock Band
20th Oct, Thursday	None
21st Oct, Friday	Fash-p
22nd Oct, Saturday	Debate
23rd Oct, Sunday	None
24th Oct, Monday	Street Play
25th Oct, Tuesday	Group Song
26th Oct, Wednesday	Folk Dance

From the table, we can see that the cultural week started with Rock Band. Hence, option D is the correct answer.

CMAT Free Solved Previous Papers.

Question 32

How many days gap is there between rock band competition and group song competition?

- A Two
- B Three
- C Four
- D Five

Answer: D

Explanation:

Let us draw a table consisting the day and competition.

Day	Competition
19th Oct, Wednesday	
20th Oct, Thursday	
21st Oct, Friday	
22nd Oct, Saturday	
23rd Oct, Sunday	
24th Oct, Monday	
25th Oct, Tuesday	
26th Oct, Wednesday	

In statement 5, it is given that none of the competition was conducted on Thursday and Sunday. Also, Street Play competition was held on Monday.

Day	Competition
19th Oct, Wednesday	
20th Oct, Thursday	None
21st Oct, Friday	
22nd Oct, Saturday	
23rd Oct, Sunday	None
24th Oct, Monday	Street Play
25th Oct, Tuesday	
26th Oct, Wednesday	

It is given that Group Song competition was conducted neither on Wednesday nor on Saturday. Hence, the Group Song competition can take place on either Tuesday or Friday. We are also given that there was gap of two days between Debate competition and Group Song competition.

If the Group Song competition is on Friday, then Debate competition should take place in 24th Oct, Monday but that slot is already filled. Hence, this case is not possible. Therefore, we can say that Group Song competition was on Tuesday. Consecutively, we can say that the Debate competition was on Saturday.

Day	Competition
19th Oct, Wednesday	
20th Oct, Thursday	None
21st Oct, Friday	
22nd Oct, Saturday	Debate
23rd Oct, Sunday	None
24th Oct, Monday	Street Play
25th Oct, Tuesday	Group Song
26th Oct, Wednesday	

Rock band competition was not conducted on the closing day. Hence, we can say that Rock Band competition took place on either 19th Oct or 21st Oct.

It is also given that Fash-p was conducted on the day prior to debate competition. Hence, we can say that Fash-P was conducted on 21st Oct Friday. Consequently, we can say that Rock Band competition took place on 19th Oct Wednesday.

Also, we can say that folk dance competition held on 26th Oct.

Day	Competition
19th Oct, Wednesday	Rock Band
20th Oct, Thursday	None
21st Oct, Friday	Fash-p
22nd Oct, Saturday	Debate
23rd Oct, Sunday	None
24th Oct, Monday	Street Play
25th Oct, Tuesday	Group Song
26th Oct, Wednesday	Folk Dance

From the table, we can see that there is a gap of 5 days between rock band competition and group song competition. Hence, option D is the correct answer.

Question 33

Which pair of competition was conducted on Wednesday?

- A Rock band competition and debate competition
- B Debate competition and fash-p competition
- C Rock band competition and Folk dance competition
- D None of these

Answer: C

Explanation:

Let us draw a table consisting the day and competition.

Day	Competition
19th Oct, Wednesday	
20th Oct, Thursday	
21st Oct, Friday	
22nd Oct, Saturday	
23rd Oct, Sunday	
24th Oct, Monday	
25th Oct, Tuesday	
26th Oct, Wednesday	

In statement 5, it is given that none of the competition was conducted on Thursday and Sunday. Also, Street Play competition was held on Monday.

Day	Competition
19th Oct, Wednesday	
20th Oct, Thursday	None
21st Oct, Friday	
22nd Oct, Saturday	
23rd Oct, Sunday	None
24th Oct, Monday	Street Play
25th Oct, Tuesday	
26th Oct, Wednesday	

It is given that Group Song competition was conducted neither on Wednesday nor on Saturday. Hence, the Group Song competition can take place on either Tuesday or Friday. We are also given that there was gap of two days between Debate competition and Group Song competition.

If the Group Song competition is on Friday, then Debate competition should take place in 24th Oct, Monday but that slot is already filled. Hence, this case is not possible. Therefore, we can say that Group Song competition was on Tuesday. Consecutively, we can say that the Debate competition was on Saturday.

Day	Competition
19th Oct, Wednesday	
20th Oct, Thursday	None
21st Oct, Friday	
22nd Oct, Saturday	Debate
23rd Oct, Sunday	None
24th Oct, Monday	Street Play
25th Oct, Tuesday	Group Song
26th Oct, Wednesday	

Rock band competition was not conducted on the closing day. Hence, we can say that Rock Band competition took place on either 19th Oct or 21st Oct.

It is also given that Fash-p was conducted on the day prior to debate competition. Hence, we can say that Fash-P was conducted on 21st Oct Friday. Consequently, we can say that Rock Band competition took place on 19th Oct Wednesday.

Also, we can say that folk dance competition held on 26th Oct.

Day	Competition
19th Oct, Wednesday	Rock Band
20th Oct, Thursday	None
21st Oct, Friday	Fash-p
22nd Oct, Saturday	Debate
23rd Oct, Sunday	None
24th Oct, Monday	Street Play
25th Oct, Tuesday	Group Song
26th Oct, Wednesday	Folk Dance

From the table, we can see that Rock Band and Folk Dance were conducted on Wednesdays.

Hence, option C is the correct answer.

Question 34

Which competition exactly precedes the street play competition?

- A Rock band competition
- B Group song competition
- C Debate competition
- D Fash-p competition

Answer: C

Explanation:

Let us draw a table consisting the day and competition.

Day	Competition
19th Oct, Wednesday	
20th Oct, Thursday	
21st Oct, Friday	
22nd Oct, Saturday	
23rd Oct, Sunday	
24th Oct, Monday	
25th Oct, Tuesday	
26th Oct, Wednesday	

In statement 5, it is given that none of the competition was conducted on Thursday and Sunday. Also, Street Play competition was held on Monday.

Day	Competition
19th Oct, Wednesday	
20th Oct, Thursday	None
21st Oct, Friday	
22nd Oct, Saturday	
23rd Oct, Sunday	None
24th Oct, Monday	Street Play
25th Oct, Tuesday	
26th Oct, Wednesday	

It is given that Group Song competition was conducted neither on Wednesday nor on Saturday. Hence, the Group Song competition can take place on either Tuesday or Friday. We are also given that there was gap of two days between Debate competition and Group Song competition.

If the Group Song competition is on Friday, then Debate competition should take place in 24th Oct, Monday but that slot is already filled. Hence, this case is not possible. Therefore, we can say that Group Song competition was on Tuesday. Consecutively, we can say that the Debate competition was on Saturday.

Day	Competition
19th Oct, Wednesday	
20th Oct, Thursday	None
21st Oct, Friday	
22nd Oct, Saturday	Debate
23rd Oct, Sunday	None
24th Oct, Monday	Street Play
25th Oct, Tuesday	Group Song
26th Oct, Wednesday	

Rock band competition was not conducted on the closing day. Hence, we can say that Rock Band competition took place on either 19th Oct or 21st Oct.

It is also given that Fash-p was conducted on the day prior to debate competition. Hence, we can say that Fash-P was conducted on 21st Oct Friday. Consequently, we can say that Rock Band competition took place on 19th Oct Wednesday.

Also, we can say that folk dance competition held on 26th Oct.

Day	Competition
19th Oct, Wednesday	Rock Band
20th Oct, Thursday	None
21st Oct, Friday	Fash-p
22nd Oct, Saturday	Debate
23rd Oct, Sunday	None
24th Oct, Monday	Street Play
25th Oct, Tuesday	Group Song
26th Oct, Wednesday	Folk Dance

From the table, we can see that Debate competition precedes the street play competition. Hence, option C is the correct answer.

MAT Free Solved Previous Papers

Question 35

Fash-p competition follows which competition?

- A Debate competition
- B Street play competition
- C Rock band competition
- D None of these

Answer: C

Explanation:

Let us draw a table consisting the day and competition.

Day	Competition
19th Oct, Wednesday	
20th Oct, Thursday	
21st Oct, Friday	
22nd Oct, Saturday	
23rd Oct, Sunday	
24th Oct, Monday	
25th Oct, Tuesday	
26th Oct, Wednesday	

In statement 5, it is given that none of the competition was conducted on Thursday and Sunday. Also, Street Play competition was held on Monday.

Day	Competition
19th Oct, Wednesday	
20th Oct, Thursday	None
21st Oct, Friday	
22nd Oct, Saturday	
23rd Oct, Sunday	None
24th Oct, Monday	Street Play
25th Oct, Tuesday	
26th Oct, Wednesday	

It is given that Group Song competition was conducted neither on Wednesday nor on Saturday. Hence, the Group Song competition can take place on either Tuesday or Friday. We are also given that there was gap of two days between Debate competition and Group Song competition.

If the Group Song competition is on Friday, then Debate competition should take place in 24th Oct, Monday but that slot is already filled. Hence, this case is not possible. Therefore, we can say that Group Song competition was on Tuesday. Consecutively, we can say that the Debate competition was on Saturday.

Day	Competition
19th Oct, Wednesday	
20th Oct, Thursday	None
21st Oct, Friday	
22nd Oct, Saturday	Debate
23rd Oct, Sunday	None
24th Oct, Monday	Street Play
25th Oct, Tuesday	Group Song
26th Oct, Wednesday	

Rock band competition was not conducted on the closing day. Hence, we can say that Rock Band competition took place on either 19th Oct or 21st Oct.

It is also given that Fash-p was conducted on the day prior to debate competition. Hence, we can say that Fash-P was conducted on 21st Oct Friday. Consequently, we can say that Rock Band competition took place on 19th Oct Wednesday.

Also, we can say that folk dance competition held on 26th Oct.

Day	Competition
19th Oct, Wednesday	Rock Band
20th Oct, Thursday	None
21st Oct, Friday	Fash-p
22nd Oct, Saturday	Debate
23rd Oct, Sunday	None
24th Oct, Monday	Street Play
25th Oct, Tuesday	Group Song
26th Oct, Wednesday	Folk Dance

From the table, we can see that Fash-p follows Rock Band. Hence, option C is the correct answer.

Instructions

Read the information given below and answer the questions that follow the information.

A parking lot can accommodate only six cars. The six cars are parked in two rows in such a way that the front of the three cars parked in one row is facing the other three cars in the other row.

- Alto is not parked in the beginning of any row
- Esteem is second to the right of i10
- Punto, who is the neighbor of Alto is parked diagonally opposite to i10

- iv. Swift is parked in front of Alto
- v. SX4 is parked to the immediate right of Alto

Question 36

If SX4 and Esteem exchange their positions mutually then car (s) adjacent to Esteem is (are)?

- A i10 and Swift
- B Only Swift
- C Only Alto
- D Alto and Punto

Answer: C

Explanation:

It is given that Esteem is second to the right of i10. Punto, who is the neighbor of Alto is parked diagonally opposite to i10. We can draw the diagram as shown in the figure below.

	Alto	Punto
i10		Esteem

Swift is parked in front of Alto and SX4 is parked to the immediate right of Alto.

SX4	Alto	Punto
i10	Swift	Esteem

We have arranged all six cars according to the conditions given in the question.

Now we are asked to interchange SX4 and Esteem's positions mutually and then figure out the car(s) adjacent to Esteem. These cars should be same as SX4 in the original arrangement. From the diagram, we can see that only Alto will be adjacent to Esteem in new position. Therefore, option C is the correct answer.

Question 37

If Alto changes position with i10 and Punto changes position with SX4 and Swift shifts one position to the right to accommodate Beatle then the car (s) parked adjacent to Beatle is (are)?

- A Punto only
- B i10 and SX4
- C Punto and Alto
- D Alto and Swift

Answer: D

Explanation:

It is given that Esteem is second to the right of i10. Punto, who is the neighbor of Alto is parked diagonally opposite to i10. We can draw the diagram as shown in the figure below.

	Alto	Punto
i10		Esteem

Swift is parked in front of Alto and SX4 is parked to the immediate right of Alto.

SX4	Alto	Punto
i10	Swift	Esteem

We have arranged all six cars according to the conditions given in the question.

It is given that Alto changes position with i10 and Punto changes position with SX4 and Swift shifts one position to the right to accommodate Beate.

Punto	i10	SX4	
Alto	Beate	Swift	Esteem

From, the arrangement we can see that Alto and Swift are neighbors of Beate. Hence, option D is the correct answer.

PGDBA Previous Year Papers (Download PDF) PGDBA Previous Year Papers (Download PDF)

Question 38

In the original parking scheme four new cars enter the parking lot such that Wagon-R is second to the right of i10 and Zen is second to the left of SX4. Jazz is parked second to the left to Wagon-R and Beat is parked to the right of Alto then the cars that moved out are?

- A Esteem and Swift
- B Punto and Alto
- C i10 and Alto
- D Punto and SX4

Answer: D

Explanation:

It is given that Esteem is second to the right of i10. Punto, who is the neighbor of Alto is parked diagonally opposite to i10. We can draw the diagram as shown in the figure below.

	Alto	Punto
i10		Esteem

Swift is parked in front of Alto and SX4 is parked to the immediate right of Alto.

SX4	Alto	Punto
i10	Swift	Esteem

We have arranged all six cars according to the conditions given in the question.

In the original parking scheme four new cars enter the parking lot such that Wagon-R is second to the right of i10 and Zen is second to the left of SX4. Jazz is parked second to the left to Wagon-R and Beat is parked to the right of Alto. Let us place 4 news cars - WagonR, Zen, Jazz and Beat.

Beat	Alto	Zen
Jazz	Swift	Wagon R



Hence, we can say that i10, Punto, SX4 and Esteem are moved out. Therefore, option D is the correct answer.

Instructions

Read the information given below and answer the next five questions that follow :

- i. Six friends Rahul, Kabeer, Anup, Raghu, Amit and Alok were engineering graduates. All six of them were placed in six different companies and were posted in six different locations, namely Tisco- Jamshedpur, Telco-Pune, Wipro-Bangalore, HCL- Noida, Mecon- Ranchi and Usha Martin-Kolkata. Each of them has their personal e-mail id's with different email providers i.e., Gmail, Indiatimes, Rediffmail, Yahoo, Hotmail, Sancharnet, though not necessarily in the same order.
- ii. The one having e-mail account with Sancharnet works in Noida and the one having an e-mail account with Indiatimes works for Tisco.
- iii. Amit does not stay in Bangalore and does not work for Mecon, the one who works for Mecon has an e-mail id with Gmail.
- iv. Rahul has an e-mail id with Rediffmail and works at Pune.
- v. Alok does not work for Mecon and the one who works for Wipro does not have an e-mail account with Yahoo.
- vi. Kabeer is posted in Kolkata, and does not have an account with Hotmail.
- vii. Neither Alok nor Raghu work in Noida.
- viii. The one who is posted in Ranchi has an e-mail id which is not an account of Rediffmail or Hotmail.
- ix. Anup is posted in Jamshedpur.

Question 39

The man who works in Wipro has a e-mail account with?

- A Sancharnet
- B Yahoo

C Rediffmail

D None of these

Answer: D

Explanation:

Let us draw the table first.

Person	Company	Place	Perosnal e-mail address

It is given that Anup is posted in Jamshedpur and Kabir is posted in Kolkata. Also, Rahul has an e-mail id with Rediffmail and works at Pune.

Person	Company	Place	Perosnal e-mail address
Rahul	Telco	Pune	Rediffmail
Kabeer	Usha Martin	Kolkata	
Anup	Tisco	Jamshedpur	
Raghu			
Amit			
Alok			

It is given that neither Alok nor Raghu work in Noida. Hence, we can say that Amit work in HCL-Noida. Also, the one having e-mail account with Sancharnet works in Noida. Hence we can say that Amit has Sancharnet's email address.

Also, the one having an e-mail account with Indiatimes works for Tisco. Hence, we can say that Anup has Indiatimes's email account.

Person	Company	Place	Perosnal e-mail address
Rahul	Telco	Pune	Rediffmail
Kabeer	Usha Martin	Kolkata	
Anup	Tisco	Jamshedpur	Indiatimes
Raghu			
Amit	HCL	Noida	Sancharnet
Alok			

Alok does not work for Mecon. Hence, we can say that Raghu works in Mecon-Ranchi. Consequently, we can say that Alok work in Wipro-Bangalore.

Also, the one who works for Mecon has an e-mail id with Gmail.

Person	Company	Place	Perosnal e-mail address
Rahul	Telco	Pune	Rediffmail
Kabeer	Usha Martin	Kolkata	
Anup	Tisco	Jamshedpur	Indiatimes
Raghu	Mecon	Ranchi	Gmail
Amit	HCL	Noida	Sancharnet
Alok	Wipro	Bangalore	

The one who works for Wipro does not have an e-mail account with Yahoo. Hence, we can say that Kabeer has yahoo's email account and Alock has hotmail's email account.

Person	Company	Place	Perosnal e-mail address
Rahul	Telco	Pune	Rediffmail
Kabeer	Usha Martin	Kolkata	Yahoo
Anup	Tisco	Jamshedpur	Indiatimes
Raghu	Mecon	Ranchi	Gmail
Amit	HCL	Noida	Sancharnet
Alok	Wipro	Bangalore	Hotmail

From the table, we can see that the man who works in Wipro has a e-mail account with hotmail. Hence, option D is the correct answer.

Question 40

Which of the following e-mail-place of posting- person combination is correct?

- A Kabeer-Kolkata-Rediffmail
- B Alok-Bangalore-Indiatimes
- C Amit-Noida-Yahoo
- D Raghu-Ranchi-Gmail

Answer: D

Explanation:

Let us draw the table first.

Person	Company	Place	Perosnal e-mail address

It is given that Anup is posted in Jamshedpur and Kabir is posted in Kolkata. Also, Rahul has an e-mail id with Rediffmail and works at Pune.

Person	Company	Place	Perosnal e-mail address
Rahul	Telco	Pune	Rediffmail
Kabeer	Usha Martin	Kolkata	
Anup	Tisco	Jamshedpur	
Raghu			
Amit			
Alok			

It is given that neither Alok nor Raghu work in Noida. Hence, we can say that Amit work in HCL-Noida. Also, the one having e-mail account with Sancharnet works in Noida. Hence we can say that Amit has Sancharnet's email address.

Also, the one having an e-mail account with Indiatimes works for Tisco. Hence, we can say that Anup has Indiatimes's email account.

Person	Company	Place	Perosnal e-mail address
Rahul	Telco	Pune	Rediffmail
Kabeer	Usha Martin	Kolkata	
Anup	Tisco	Jamshedpur	Indiatimes
Raghu			
Amit	HCL	Noida	Sancharnet
Alok			

Alok does not work for Mecon. Hence, we can say that Raghu works in Mecon-Ranchi. Consequently, we can say that Alok work in Wipro-Bangalore.

Also, the one who works for Mecon has an e-mail id with Gmail.

Person	Company	Place	Perosnal e-mail address
Rahul	Telco	Pune	Rediffmail
Kabeer	Usha Martin	Kolkata	
Anup	Tisco	Jamshedpur	Indiatimes
Raghu	Mecon	Ranchi	Gmail
Amit	HCL	Noida	Sancharnet
Alok	Wipro	Bangalore	

The one who works for Wipro does not have an e-mail account with Yahoo. Hence, we can say that Kabeer has yahoo's email account and Alock has hotmail's email account.

Person	Company	Place	Perosnal e-mail address
Rahul	Telco	Pune	Rediffmail
Kabeer	Usha Martin	Kolkata	Yahoo
Anup	Tisco	Jamshedpur	Indiatimes
Raghu	Mecon	Ranchi	Gmail
Amit	HCL	Noida	Sancharnet
Alok	Wipro	Bangalore	Hotmail

From the table, we can see that Raghu-Ranchi-Gmail is a correct combination. Hence, option D is the correct ansy

CAT Previous Papers PDF

Question 41

Which of the following is true?

- A Amit is posted at Ranchi
- B Raghu is posted at Jamshedpur
- C Kabeer has an e-mail id with Yahoo
- D Rahul has an e-mail id with Indiatimes

Answer: C

Explanation:

Let us draw the table first.

Person	Company	Place	Perosnal e-mail address

It is given that Anup is posted in Jamshedpur and Kabir is posted in Kolkata. Also, Rahul has an e-mail id with Rediffmail and works at Pune.

Person	Company	Place	Perosnal e-mail address
Rahul	Telco	Pune	Rediffmail
Kabeer	Usha Martin	Kolkata	
Anup	Tisco	Jamshedpur	
Raghu			
Amit			
Alok			

It is given that neither Alok nor Raghu work in Noida. Hence, we can say that Amit work in HCL-Noida. Also, the one having e-mail account with Sancharnet works in Noida. Hence we can say that Amit has Sancharnet's email address.

Also, the one having an e-mail account with Indiatimes works for Tisco. Hence, we can say that Anup has Indiatimes's email account.

Person	Company	Place	Perosnal e-mail address
Rahul	Telco	Pune	Rediffmail
Kabeer	Usha Martin	Kolkata	
Anup	Tisco	Jamshedpur	Indiatimes
Raghu			
Amit	HCL	Noida	Sancharnet
Alok			

Alok does not work for Mecon. Hence, we can say that Raghu works in Mecon-Ranchi. Consequently, we can say that Alok work in Wipro-Bangalore.

Also, the one who works for Mecon has an e-mail id with Gmail.

Person	Company	Place	Perosnal e-mail address
Rahul	Telco	Pune	Rediffmail
Kabeer	Usha Martin	Kolkata	
Anup	Tisco	Jamshedpur	Indiatimes
Raghu	Mecon	Ranchi	Gmail
Amit	HCL	Noida	Sancharnet
Alok	Wipro	Bangalore	

The one who works for Wipro does not have an e-mail account with Yahoo. Hence, we can say that Kabeer has yahoo's email account and Alock has hotmail's email account.

Person	Company	Place	Perosnal e-mail address
Rahul	Telco	Pune	Rediffmail
Kabeer	Usha Martin	Kolkata	Yahoo
Anup	Tisco	Jamshedpur	Indiatimes
Raghu	Mecon	Ranchi	Gmail
Amit	HCL	Noida	Sancharnet
Alok	Wipro	Bangalore	Hotmail

From the table, we can see that Kabeer has an e-mail id with Yahoo. Hence, option C is the correct answer.

Question 42

Which of the following sequences of location represent Alok, Kabeer, Anup, Rahul, Raghu, and Amit in the same order?

- A Bangalore, Noida, Pune, Jamshedpur, Ranchi, Kolkata
- B Bangalore, Kolkata, Jamshedpur, Pune, Noida, Ranchi
- C Kolkata, Bangalore, Jamshedpur, Pune, Noida, Ranchi
- D None of these

Answer: D

Explanation:

Let us draw the table first.

Person	Company	Place	Perosnal e-mail address

It is given that Anup is posted in Jamshedpur and Kabir is posted in Kolkata. Also, Rahul has an e-mail id with Rediffmail and works at Pune.

Person	Company	Place	Perosnal e-mail address
Rahul	Telco	Pune	Rediffmail
Kabeer	Usha Martin	Kolkata	
Anup	Tisco	Jamshedpur	
Raghu			
Amit			
Alok			

It is given that neither Alok nor Raghu work in Noida. Hence, we can say that Amit work in HCL-Noida. Also, the one having e-mail account with Sancharnet works in Noida. Hence we can say that Amit has Sancharnet's email address.

Also, the one having an e-mail account with Indiatimes works for Tisco. Hence, we can say that Anup has Indiatimes's email account.

Person	Company	Place	Perosnal e-mail address
Rahul	Telco	Pune	Rediffmail
Kabeer	Usha Martin	Kolkata	
Anup	Tisco	Jamshedpur	Indiatimes
Raghu			
Amit	HCL	Noida	Sancharnet
Alok			

Alok does not work for Mecon. Hence, we can say that Raghu works in Mecon-Ranchi. Consequently, we can say that Alok work in Wipro-Bangalore.

Also, the one who works for Mecon has an e-mail id with Gmail.

Person	Company	Place	Perosnal e-mail address
Rahul	Telco	Pune	Rediffmail
Kabeer	Usha Martin	Kolkata	
Anup	Tisco	Jamshedpur	Indiatimes
Raghu	Mecon	Ranchi	Gmail
Amit	HCL	Noida	Sancharnet
Alok	Wipro	Bangalore	

The one who works for Wipro does not have an e-mail account with Yahoo. Hence, we can say that Kabeer has yahoo's email account and Alock has hotmail's email account.

Person	Company	Place	Perosnal e-mail address
Rahul	Telco	Pune	Rediffmail
Kabeer	Usha Martin	Kolkata	Yahoo
Anup	Tisco	Jamshedpur	Indiatimes
Raghu	Mecon	Ranchi	Gmail
Amit	HCL	Noida	Sancharnet
Alok	Wipro	Bangalore	Hotmail

From the table, we can see that Alok, Kabeer, Anup, Rahul, Raghu, and Amit work in Bangalore, Kolkata, Jamshedpur, Pune, Ranchi and Noida in that order. None of the option represents the same sequence. Hence, option D is the correct answer.

Question 43

People who have e-mail account with Indiatimes, Sancharnet and Yahoo work for which companies, in the same sequence as the e-mail accounts mentioned?

- A Usha Martin, HCL, Wipro
- B Tisco, Wipro, Usha Martin
- C HCL, Tisco, Wipro
- D Tisco, HCL, Usha Martin

Answer: D

Explanation:

Let us draw the table first.

Person	Company	Place	Perosnal e-mail address

It is given that Anup is posted in Jamshedpur and Kabir is posted in Kolkata. Also, Rahul has an e-mail id with Rediffmail and works at Pune.

Person	Company	Place	Perosnal e-mail address
Rahul	Telco	Pune	Rediffmail
Kabeer	Usha Martin	Kolkata	
Anup	Tisco	Jamshedpur	
Raghu			
Amit			
Alok			

It is given that neither Alok nor Raghu work in Noida. Hence, we can say that Amit work in HCL-Noida. Also, the one having e-mail account with Sancharnet works in Noida. Hence we can say that Amit has Sancharnet's email address.

Also, the one having an e-mail account with Indiatimes works for Tisco. Hence, we can say that Anup has Indiatimes's email account.

Person	Company	Place	Perosnal e-mail address
Rahul	Telco	Pune	Rediffmail
Kabeer	Usha Martin	Kolkata	
Anup	Tisco	Jamshedpur	Indiatimes
Raghu			
Amit	HCL	Noida	Sancharnet
Alok			

Alok does not work for Mecon. Hence, we can say that Raghu works in Mecon-Ranchi. Consequently, we can say that Alok work in Wipro-Bangalore.

Also, the one who works for Mecon has an e-mail id with Gmail.

Person	Company	Place	Perosnal e-mail address
Rahul	Telco	Pune	Rediffmail
Kabeer	Usha Martin	Kolkata	
Anup	Tisco	Jamshedpur	Indiatimes
Raghu	Mecon	Ranchi	Gmail
Amit	HCL	Noida	Sancharnet
Alok	Wipro	Bangalore	

The one who works for Wipro does not have an e-mail account with Yahoo. Hence, we can say that Kabeer has yahoo's email account and Alock has hotmail's email account.

Person	Company	Place	Perosnal e-mail address
Rahul	Telco	Pune	Rediffmail
Kabeer	Usha Martin	Kolkata	Yahoo
Anup	Tisco	Jamshedpur	Indiatimes
Raghu	Mecon	Ranchi	Gmail
Amit	HCL	Noida	Sancharnet
Alok	Wipro	Bangalore	Hotmail

From the table, we can see that people who have e-mail account with Indiatimes, Sancharnet and Yahoo work Tisco, HCL and Usha Martin in that order. Hence, option D is the correct answer.

Take a XAT Free Mock Test

Instructions

For the following questions answer them individually

Question 44

How many 'zeroes' are there in the following sequence which are immediately preceded by a nine but not immediately followed by seven?

7090070890702030045703907

- A One
- B Two
- C Three
- D Four

Answer: A

Explanation:

We can see that only one zero present in the number such that it is immediately preceded by a nine but not immediately followed by seven. It is shown in round braces. 4th from the left.

709(0)070890702030045703907

Therefore, option A is the correct answer.

Question 45

A Retail chain has seven branches in a city namely R1, R2, R3, R4, R5, R6, R7 and a central distribution center (DC). The nearest branch to the DC is R6 which is in the south of DC and is 9 Km away from DC. R2 is 17 Km away from DC in the west. The branch R1 is 11 Km away R2 further in the west. The branch R3 is 11 Km in the north east of R1. R4 is 13 Km from R3 in the east. R5 is 11 Km in the north east of the distribution center. In the north east of R6 is R7 and distance between them is 15 Km. The distance between R1 and R6, R2 and R6, R6 and R5 is 23 Km, 19 Km, 13 Km respectively. R3 is 14 Km away from the DC in the north west direction, while R2 is also 14 Km away from R4 in the north east direction of R2. A truck carrying some goods starts from the distribution center and has to cover at least four stores in a single trip. There is an essential good that has to be delivered in the store R7, but the delivery at R7 has to be done in the end, so what is the shortest distance the truck would travel?

- A 55
- B 56
- C 63
- D 66

Answer: C

Explanation:

Let us draw the network diagram according to the given info.

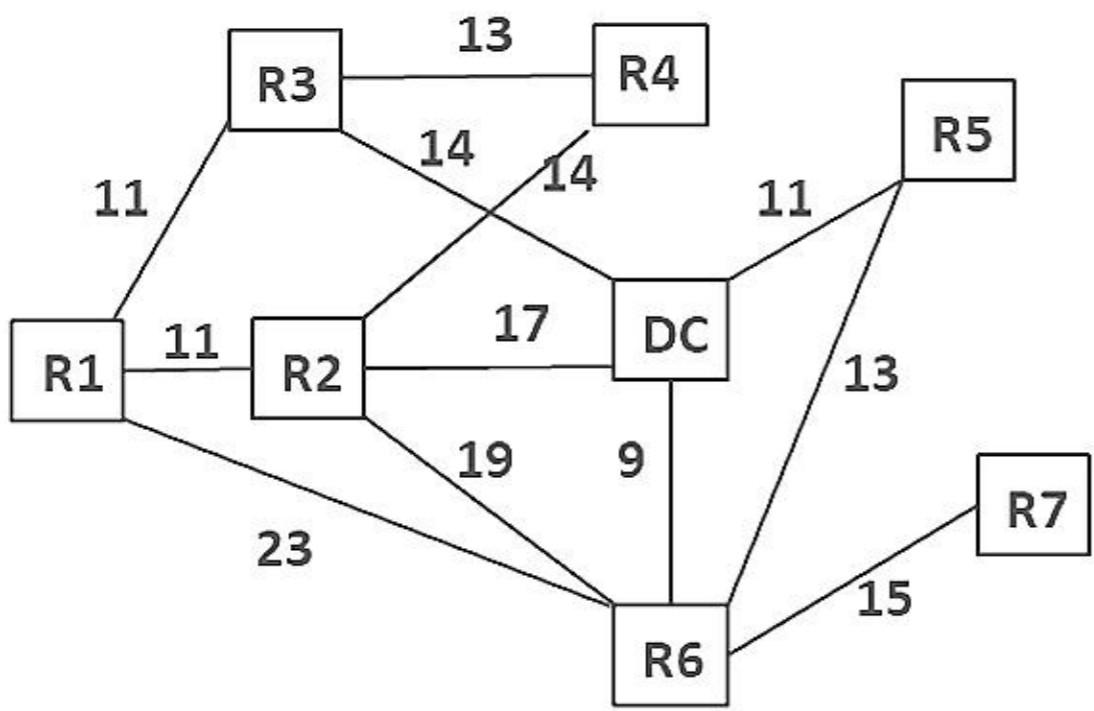

The shortest route for the truck would be DC-R3-R1-R6-R7. Thus, the total distance traveled would be $14 + 11 + 23 + 15 = 63$ km. Hence, option C is the correct answer.

Instructions

Following graph represents the cost per square feet of four retailers from the financial year 2004 to 2012. The expected cost per square feet for year 2010, 2011 and 2012 are fore casted figures.

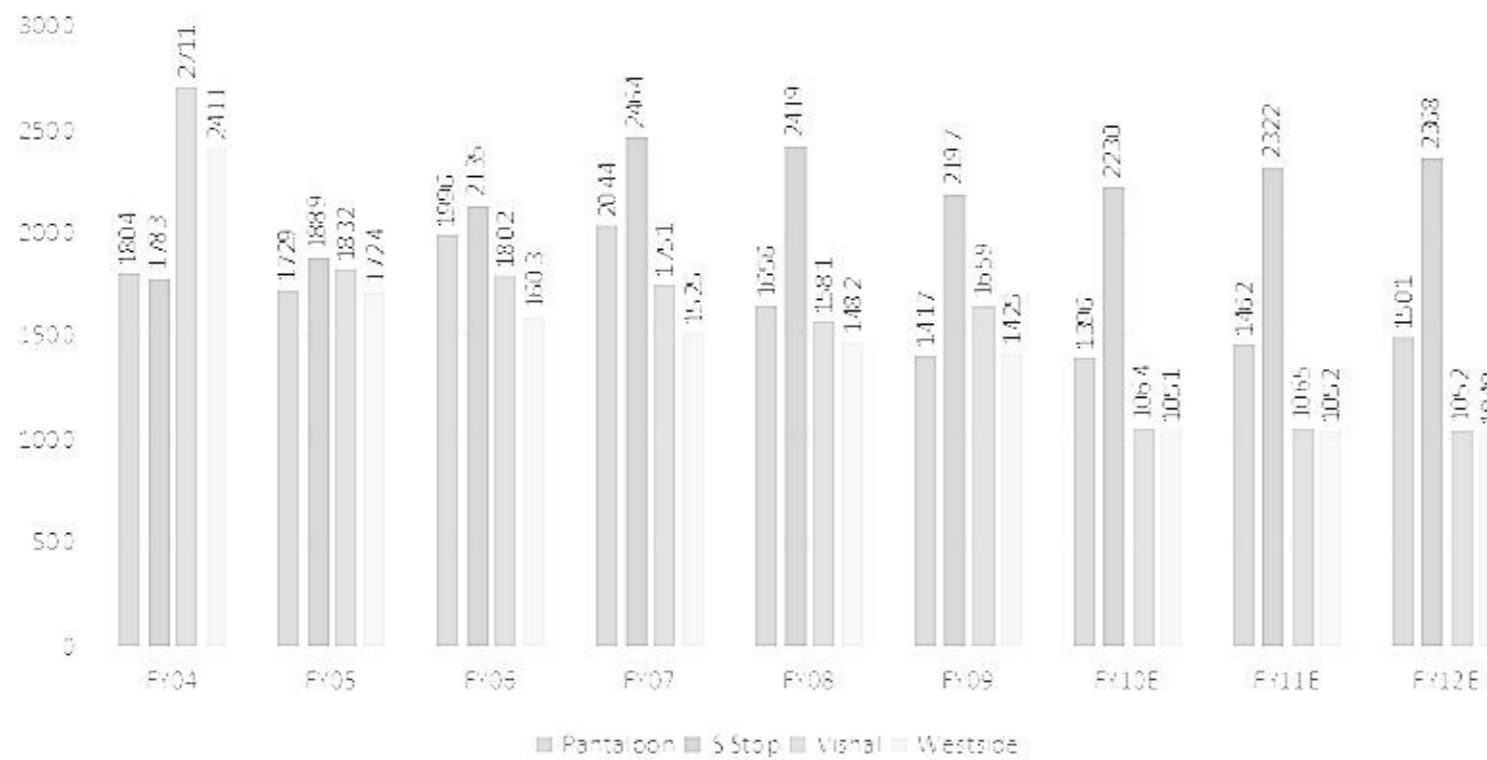

Question 46

Which retailer shows the sharpest decline in cost per square feet and in which year?

- A Westside, 2005
- B Pantaloon, 2008
- C S. Stop, 2009
- D Vishal, 2010

Answer: A

Explanation:

Let us check the option one by one.

- (A) For Westside, the decline in cost per square feet in the year 2005 = $2411 - 1724 = 687$
- (B) For Pantaloon, the decline in cost per square feet in the year 2008 = $2044 - 1656 = 388$
- (C) For S. Stop, the decline in cost per square feet in the year 2009 = $2419 - 2197 = 222$
- (D) For Vishal, the decline in cost per square feet in the year 2010 = $1659 - 1064 = 595$

We can see that the sharpest decline is for Westside stores in the year 2005. Hence, option A is the correct answer.

Take a CMAT free mock test

Question 47

Which retailer has shown the maximum increase in its cost per square feet and in which year?

- A S. Stop, 2006
- B S. Stop, 2007
- C Pantaloon, 2006
- D Vishal, 2006

Answer: B

Explanation:

Let us check the option one by one.

- (A) For S. Stop, the increase in cost per square feet in the year 2006 = $2135 - 1889 = 246$
- (B) For S. Stop, the increase in cost per square feet in the year 2007 = $2464 - 2135 = 329$

(C) For Pantaloon, the increase in cost per square feet in the year 2006 = $\$1996-1729\$ = 267$

(D) For Vishal, the increase in cost per square feet in the year 2006 = $\$1802-1832\$ = -30$

We can see that the maximum increase in its cost per square feet is for S.stop stores in the year 2007. Hence, option B is the correct answer.

Question 48

What is the average rate of change in the cost per square feet of the retail sector, if the sector is represented by the above four retailers in the period FY07 to FY10E?

- A -8.12
- B -10.86
- C -6.73
- D None of these

Answer: D

Explanation:

The cost per square feet of the retail sector, in the year 2007 = $2044+2464+1751+1525 = 7784$

The cost per square feet of the retail sector, in the year 2010E = $1396+2230+1064+1051 = 5741$

Therefore, What is the average rate of change in the cost per square feet of the retail sector for the given period = $\frac{5741-7784}{7784} \times 100 = -8.74\%$ percent. Hence, option D is the correct answer.

Instructions

The table below represents the information collected by TRAI about the Service Area wise Access of (Wireless + Wire line) subscribers in India. On the basis of the information provided in the table answer the questions that follow.

Service Area	Subscribers(in Millions)		Service Area	Subscribers(in Millions)	
	Dec-09	Mar-10		Dec-09	Mar-10
U.P.(E)	39.68	45.53	Orissa	13.57	15.89
Bihar	33.17	38.36	Mumbai	27.21	29.43
Karnataka	35.5	39.91	Kerala	25.69	27.65
Andhra Pradesh	43.89	48.09	Punjab	20.03	21.7
TN(Chennai Included)	53.17	57.26	Delhi	29.38	31.01
Madhya Pradesh	29.89	33.55	Haryana	13.59	14.96
Maharashtra	43.02	46.53	Kolkata	16.55	17.87
U.P.(W)	28.47	31.97	Assam	8.11	9.06
West Bengal	22.68	26.07	North East	4.94	5.64
Gujarat	31.37	34.43	Jammu And Kashmir	5.22	5.78
Rajasthan	32.22	35.27	Himachal Pradesh	4.83	5.34

Question 49

Which service area has observed maximum rate of change from Dec 2009 to March 2010 (in percentage)?

- A U.P. (E)
- B Bihar
- C Orissa
- D Haryana

Answer: C

Explanation:

The percentage change in number of subscribers in March 10 as compared to Dec 09 in U.P. (E) = $\frac{45.53-39.68}{39.68} \times 100 = 14.74\%$ percent

The percentage change in number of subscribers in March 10 as compared to Dec 09 in Bihar = $\frac{38.36-33.17}{33.17} \times 100 = 15.64$ percent

The percentage change in number of subscribers in March 10 as compared to Dec 09 in Orissa = $\frac{15.89-13.57}{13.57} \times 100 = 17.09$ percent

The percentage change in number of subscribers in March 10 as compared to Dec 09 in Haryana = $\frac{14.96-13.59}{13.59} \times 100 = 10.08$ percent

We can see that Orissa observed maximum rate of change from Dec 2009 to March 2010. Hence, option C is the correct answer.

Take a free SNAP mock test

Question 50

As a result of a decision to allow only two or three telecom operators in a particular service area, TRAI allocates R-Com and Vodafone to operate only in the east of India and Idea and Airtel operate only in south. R-Com has got 28% subscribers in the east while Vodafone has 72% subscribers; similarly Idea has 48% subscribers in the south while Airtel has 52% subscribers. How many subscribers do these four players have in 2010?

- A R-Com-28.03, Vodafone-73.22, Idea-86.22, Airtel-89.5
- B R-Com-30.03, Vodafone-72.82, Idea-85.02, Airtel-80.04
- C R-Com-28.03, Vodafone-76.24, Idea-84.01, Airtel-85.67
- D R-Com-30.03, Vodafone-77.22, Idea-82.99, Airtel-89.91

Answer: D

Explanation:

It is given that R-com has 28% subscribers in the east and Vodafone has 72% subscribers in the east, these two are the only operators in the east.

Similarly, Idea and Airtel are the only players in the south whose shares are 48% and 52% respectively.

We are not given that name of the states which need to be considered under southern part of the country. But the number of subscribers should be in the same ratio of shares.

Checking with the options

Option (A): R-Com's share = $\frac{28.03}{28.03+73.22} \times 100 = 27.68$ percent. We are given that Rcom has 28% shares. Hence, this option is incorrect.

Option (B): R-Com's share = $\frac{30.03}{30.03+72.82} \times 100 = 29.19$ percent. We are given that Rcom has 28% shares. Hence, this option is incorrect.

Option (C): R-Com's share = $\frac{28.03}{28.03+76.24} \times 100 = 26.88$ percent. We are given that Rcom has 28% shares. Hence, this option is incorrect.

Option (D): R-Com's share = $\frac{30.03}{30.03+77.22} \times 100 = 28$ percent. We are given that Rcom has 28% shares. Hence, this option is the correct.

Question 51

Due to operability issues early in 2010 Madhya Pradesh and entire UP was added to the eastern telecom circle. The telecom operators in Madhya Pradesh and entire UP namely R-Com, Vodafone and Idea had 28%, 40% and 32% subscribers respectively. What is the percentage of subscribers that each player has in the newly formed eastern circle in March 2010?

- A R-Com-30.01%, Vodafone-55.72%, Idea-14.27%
- B R-Com-32.01%, Vodafone-53.72%, Idea-14.27%
- C R-Com-28%, Vodafone-55.72%, Idea-16.27%
- D None of these

Answer: D

Explanation:

This question does not state explicitly that data from the previous question can be used, the percentage break up given in the previous question cannot be assumed in this question. Hence, the given data is insufficient to solve the given problem. Therefore, option D is the correct answer.

Question 52

The all India rate of change in number of subscribers from December 2009 to March 2010 is?

- A 10.7%
- B 10.5%
- C 11.8%
- D 12.4%

Answer: B

Explanation:

The number of subscribers in Dec 2009 = 562.18 millions.

The number of subscribers in March 2010 = 621.30 millions.

Therefore, the required percentage = $\frac{621.30-562.18}{562.18} \times 100 = 10.51$ percent. Hence, option B is the correct answer.

Take a NMAT free mock test

Instructions

In order to quantify the intangibles and incentives to the multi brand dealers (dealers who stock multiple goods as well as competing brands) and the associated channel members, a Company(X) formulates a point score card, which is called as brand building points. This brand building point is added to the sales target achieved points for redemption. The sales target achieved point is allotted as per the table 3 of this question. The sum of brand building point and sales achieved points is the total point that can be redeemed by the dealer against certain goods, as shown in the second table.

The detail of the system is shown in the tables below

Table 1: Brands Building Score Card						
Brand Building Criteria	Points that are allotted if any of the each is achieved					
Company(X) Signage	Only Company X signage on main entrance on the store	Company X signage on the main entrance along with other brands	Company X signage in the corner of the counter	Company X signage Outside the counter	No signage of Company X	Other brands signage only
Points	20	10	5	5	0	-20
Company(X) Wall painting in the exterior of the store	Only Company X painting in the walls of the store	Company X painting on main entrance with other brands	Company X painting on the side wall of the store	Company X painting outside the store on some other structure	No painting of Company X	Other brands painting only
Points	20	5	2.5	2.5	0	-10
Company(X) painting in the interior of the store	The interior of the store has only Company X painting	Company X painting in the Back side of the counter	Company X painting on the side wall in the interior	Not painted	Others' painting only	
Points	10	5	2.5	2.5	-10	
POP (point of purchase) display of Company(X)	All POP display is of Company X	The POP display of company X is at the eye level with other brands	Above the eye level with other	Below the eye level with other brands	Store does not have any POP material	Store has only Other brands POP material
Points	25	10	5	5	0	-20
Stacking of Company (X) goods in the shelves	Goods of Company X only in the front row	Goods of Company X share front row with other brands	Company X goods are only in the back row	Goods of Other brands in the front row only		
Points	25	10	0	-20		

Sl. No	Goods in offer	Total Points required for Redemption
1	Umbrella	40
2	Nike Cap	100
3	T-Shirt	200
4	Tupperware Set	600
5	Ray Ban Glasses	800
6	Banarasi Silk Saree	2000
7	Kanjivaram Saree	4000

Sales Target	Points Assigned
<50% of the Sales Target	0
50% - 75%	10
75% - 99%	12
100%	15
Each extra unit sold above the sales target	0.25

There are 10 multi brand dealers in Nasik and the sales that they have achieved in the end of a quarter are:

Dealers	Sales Target (July-Sep) in units	Actual Sales
Bhounik Brothers	25,000	24,378
Subhajit Traders	28,000	29,241
Srikrishna Traders	40,000	42,000
Nikil Choudhary & Co	43,000	42,000
M/s Dinesh Kumar	25,000	25,000
Variety Stores	22,000	23,000
Rajib & Co	22,000	22,000
Malling Enterprise	23,000	24,000
Saha H/W	24,000	24,512
Maheshwari & Co	50,000	56,241

Question 53

Maheshwari & Co has Company X signage along with other brand signage in the main entrance of the store, the exterior walls of the store have the painting of only company X, the side wall in the interior has the painting of Company X. The POP display of Company X is above the eye level with other brands while the stacking of goods of Company X is in the back row of the shelves. The brand building points when combined with the sales achieved points amounts to the total points that a dealer can accumulate in a quarter. The number of Tupperware Sets that Maheshwari & Co can redeem after the quarter (July to September) is?

- A 2
- B 3
- C 4
- D 5

Answer: A

Explanation:

In brand building points earned by Maheshwari & Co:

Points earned for having signage board = 10

Points earned for exterior walls of the store = 20

Points earned for Company X painting in the interior of the store = 2.5

Points earned for POP display of company X = 5

Points earned for stacking of company X goods in the shelves = 0

Hence, total brand building points earned by Maheshwari & Co. = $10+20+2.5+5 = 37.50$

Also, Maheshwari & Co achieved a target more than 100%. Therefore, the sales target points earned by Maheshwari & Co = $15 + (56241-50000)*0.25 = 1575.25$.

Therefore, total redeemable points acquired by Maheshwari & Co in Jul-Sep quarter = $1575.25+37.50 = 1612.75$.

A Tupperware set can be availed by redeeming 600 points. Hence, we can say that Maheshwari & Co can avail 2 Tupperware set by the end of the quarter.

Hence, option A is the correct answer.

Question 54

Bhowmik Brothers has only other brands signage in the front of the store, and company X painting on the side wall in the exterior of the store, Company X painting on the side wall in the interior of the store, no POP display of any Company and the goods of Company X is stacked in the front row with other brands. What is the total point Bhowmik Brothers need to accumulate to make them eligible for minimum redemption?

A 27

B 37

C 38

D 33

Answer: D

Explanation:

In brand building points earned by Bhowmik Brothers:

Bhowmik Brothers has only other brands signage in the front of the store, and company X painting on the side wall in the exterior of the store, Company X painting on the side wall in the interior of the store, no POP display of any Company and the goods of Company X is stacked in the front row with other brands. What is the total point Bhowmik Brothers need to accumulate to make them eligible for minimum redemption?

Points earned for having signage board of company X = -20

Points earned for painting on the side wall in the exterior of the store = 2.5

Points earned for painting on the side wall in the interior of the store = 2.5

Points earned for POP display of company X = 0

Points earned for stacking of company X goods in the front row with other brands = 10

Hence, total brand building points earned by Bhowmik Brothers = $-20+2.5+2.5+10 = -5$

Also, Bhowmik Brothers achieved a target in 75% to 99% range. Therefore, the sales target points earned by Bhowmik Brothers = 12

Therefore, total redeemable points acquired by Bhowmik Brothers in Jul-Sep quarter = $-5 + 12 = 7$.

For minimum redemption they should have at least 40 points. Hence, we can say that Bhowmik Brothers need to accumulate 33 points to make them eligible for minimum redemption. Therefore, option D is the correct answer.

Question 55

The Brand building points of Saha H/W is 85, and Mr. Saha the proprietor of the store wants to redeem a Kanjivaram Saree the next quarter by carrying forward the points accumulated this quarter to the next quarter. The sales target of Saha H/W is 25,000 units in the next quarter. It is assumed the brand building points for the next quarter is also going to be 85. How many extra units Saha H/W has to sell in order to get the Kanjivaram Saree?

A 14688

B 12569

C 13658

D 15698

Answer: A

Explanation:

Total redeemable points earned by Saha H/W in this quarter = $85 + 15 + (24512 - 24000) * 0.25 = 228$.

Points earned by Saha H/W through brand building and completing 100% sales target = $85 + 15 = 100$.

For a Kanjivaram Saree, Saha H/W needs 4000 points. Rest of the points should be earned by selling extra units. Each extra units will garner 0.25 points for Mr. Saha.

Therefore, the number of extra units that Mr. Saha must sell in order to collect points for Kanjivaram Saree = $\frac{4000 - 228 - 100}{0.25} = 14688$.

Hence, option A is the correct answer.

Join MBA Telegram Group

Question 56

Malling Enterprise exhausted all its points while redeeming three Nike Caps and an Umbrella, what is its brand building points?

A 75

B 85

C 95

D 90

Answer: A

Explanation:

Total point earned by Malling Enterprise through sells alone = $15 + (24000 - 23000) * 0.25 = 265$.

Points required to avail three Nike Caps and an Umbrella = $3 * 100 + 40 = 340$.

Hence, Malling Enterprise must have earned through brand building activities = $340 - 265 = 75$.

Question 57

If Srikrishna Trader has 80 brand building points then the goods that it can redeem are _____?

A Tupperware set, Kanjivaram

B Umbrella and Tupperware set

C Tupperware set, Nike Cap

D Nike Cap and T-Shirt

Answer: D

Explanation:

Total point earned by Srikrishna Trader through sells alone = $15 + (42000 - 40000) * 0.25 = 515$.

Total point earned by Srikrishna Trader through brand building activities = 80.

Therefore, total redeemable points with Srikrishna Trader = $515 + 80 = 595$.

The tupperware set alone costs 600 points. Hence, option A, B and C can be ruled out. Therefore, option D is the correct answer.

Instructions

Study the following graph and answer the questions that follow

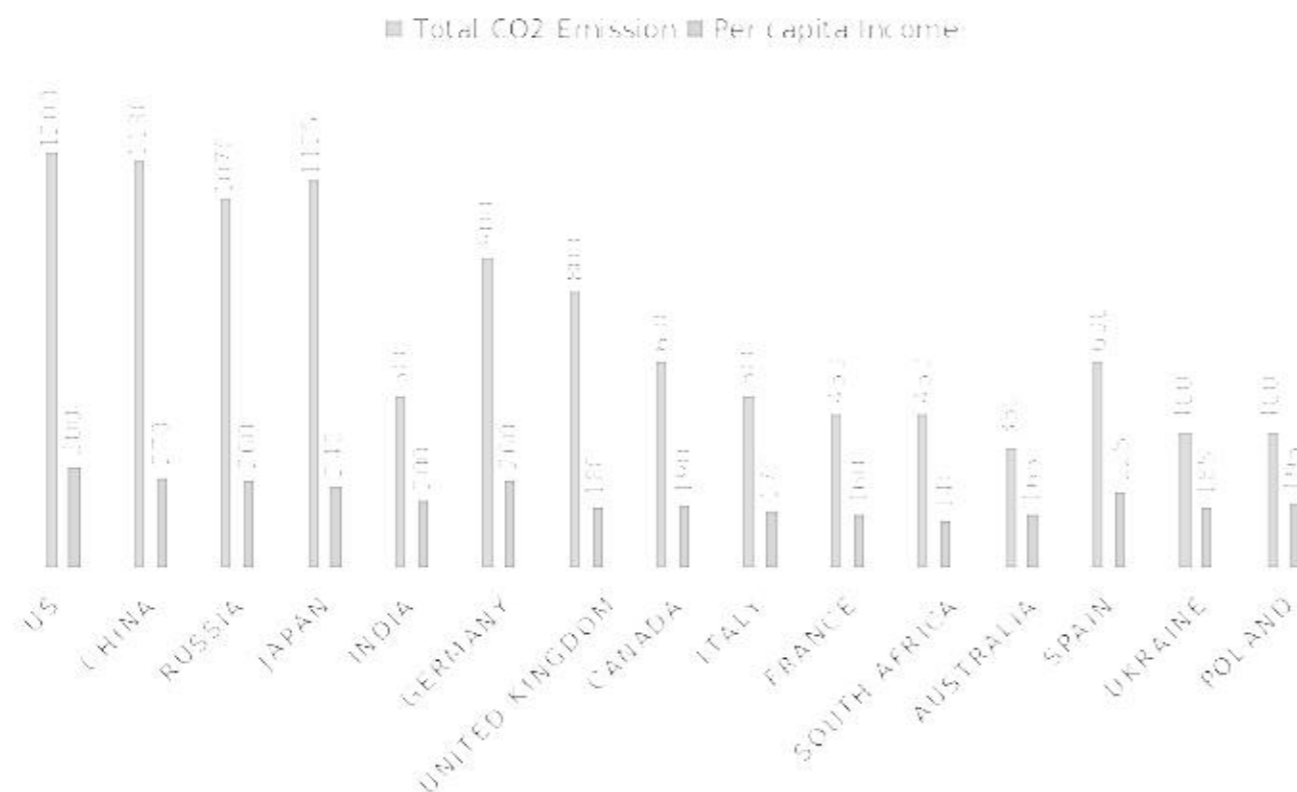

Question 58

If the world energy council formulates a norm for high emission countries to reduce their emission each year by 12.5% for the next two years then what would be the ratio of $\text{\$CO}_2\text{\$}$ emission to per capita income of US, China and Japan after two years. The per capita income of China, Japan and US is expected to increase every year by 4%, 3% and 2% respectively.

- A 3.5, 3.8, 4.1
- B 3.4, 3.5, 3.9
- C 2.9, 3.1, 3.4
- D None

Answer: C

Explanation:

$\text{\$CO}_2\text{\$}$ emission by the US after 2 years = $\text{\$}\left\{\left(1-\frac{12.5}{100}\right)^2\right\}\times 1200\text{\$}$ = 918.75 million tons.

The per capita income in US after 2 years = $\text{\$}\left\{\left(1+\frac{2}{100}\right)^2\right\}\times 300\text{\$}$ = 312.12

Similarly, we can calculate the $\text{\$CO}_2\text{\$}$ emission and per capita income for remaining countries after two years from now.

$\text{\$CO}_2\text{\$}$ emission by the China after 2 years = 903.44 million tons.

The per capita income in China after 2 years = $\text{\$}\left\{\left(1+\frac{4}{100}\right)^2\right\}\times 270\text{\$}$ = 292.032

$\text{\$CO}_2\text{\$}$ emission by the Japan after 2 years = 861.33 million tons.

The per capita income in Japan after 2 years = $\text{\$}\left\{\left(1+\frac{3}{100}\right)^2\right\}\times 240\text{\$}$ = 254.616

Hence, the required ratio = $\text{\$}\frac{918.75}{312.12}\text{\$}$, $\text{\$}\frac{903.44}{292.032}\text{\$}$, $\text{\$}\frac{861.33}{254.616}\text{\$}$, = 2.9, 3.1, 3.4.

Therefore, we can say option C is the correct answer.

Subscribe to MBA Exams Youtube Channel

Question 59

If US and China, decide to buy carbon credits, from Spain and Ukraine to make up for their high emissions, then in how many years US, and China would be able to bring down its ratio of $\text{\$CO}_2\text{\$}$ emission (million ton) to per capita income to world standard benchmark of 0.75. (per capita income of the given countries remain same, 0.5 $\text{\$CO}_2\text{\$}$ emissions [million ton] is compensated by purchase of 1.25 units of carbon credit, and a country can buy carbon credit units in three lots of 15, 20 and 30 units in a single year.)

- A 3.8 years
- B 38 years
- C 30 years

D None

Answer: B

Explanation:

CO₂ emission required for USA = 225 million tonnes
CO₂ emission required for China = 202.5 million tonnes
Required reduction for USA = 975 million tonnes
Required reduction for China = 977.5

0.5 million tone of CO₂ ----> 1.25 carbon credits

In one year, a country can purchase 65 carbon credit

In one year, 26 million tonnes of CO₂ is compensated.
Required time = $977.5 / 26 = 37.59$ years

Hence, option B is the correct answer.

Question 60

France, South Africa, Australia, Ukraine and Poland form an energy consortium which declares CO₂ emission of 350 million ton per annum as standard benchmark. The energy consortium decides to sell their carbon emission savings against the standard benchmark to high carbon emission countries. It is expected that the per capita income of each country of the energy consortium increases by 2%, 2.5% and 3.5% p.a. for the next three years respectively. The ratio of CO₂ emission to per capita income of the each energy consortium country reduces by 50% and remains constant for the next three years. By selling 0.5 CO₂ emissions [million ton] the energy consortium earns 1.25 carbon credits, then determine the total carbon credits earned by energy consortium in three years.

A 3560

B 4506

C 5060

D None

Answer: C

Explanation:

Total emission in three years combined = 2000 million tonnes.
Thus, total credit = 5000 credits (approx)

Hence, option C is the correct answer.

Question 61

Select the wrong statement in reference to the position of India vis-à-vis other countries in the graph in terms of the ratio of CO₂ emission to per capita income (increasing order).

A India stands at 5th position if 50 is added to the given per capita income figures of each country.

B India stands at 5th position at the given CO₂ emission level and per capita income of each country.

C India stands at 5th position if 200 million ton CO₂ emission is deducted from the given CO₂ emission figures of each country.

D India stands at 5th position if 200 million ton CO₂ emission is deducted from the given CO₂ emission figures of each country and 50 is added to the given per capita income of each country.

Answer: D

Explanation:

India stands at 6th position if 200 million ton CO₂ emission is deducted from the given CO₂ emission figures of each country and 50 is added to the given per capita income of each country.

Hence, option D is the correct answer.

Free Mock Test for IIFT

Instructions

Refer to the following pie chart and answer the question that follows. The chart shows the number of units produced in degrees, by Company X in different States of India for the quarter July-Sep 2010.

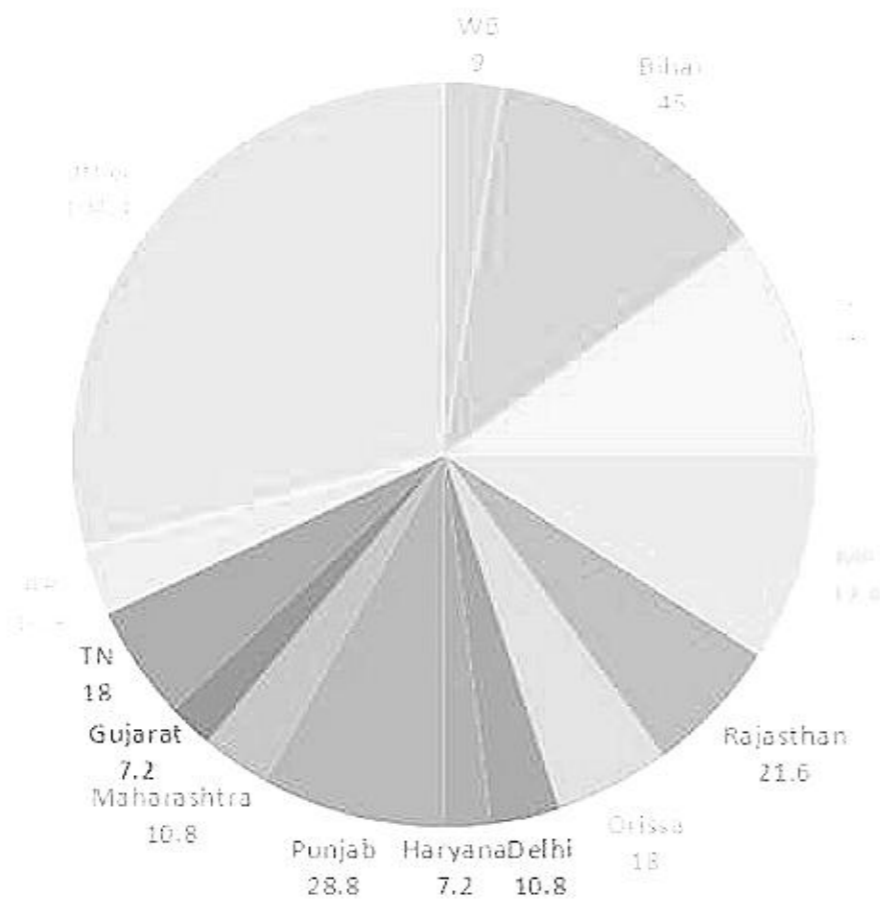

Question 62

By how many units does the number of units produced in Bihar exceed the number of units produced in Madhya Pradesh, if the total production in the quarter is 72,000 units?

- A 2300 units
- B 2520 units
- C 3516 units
- D 2860 units

Answer: B

Explanation:

The number of units produced in Bihar exceed the number of units produced in Madhya Pradesh = $\frac{45 - 32.4}{360} \times 72000 = 2520$.

Therefore, option B is the correct answer.

Instructions

The following graph shows population data (males and females), educated people data (males and females) and number of male in the population for a given period of 1995 to 2010. All data is in million.

From the information given in the graph answer the questions that follow

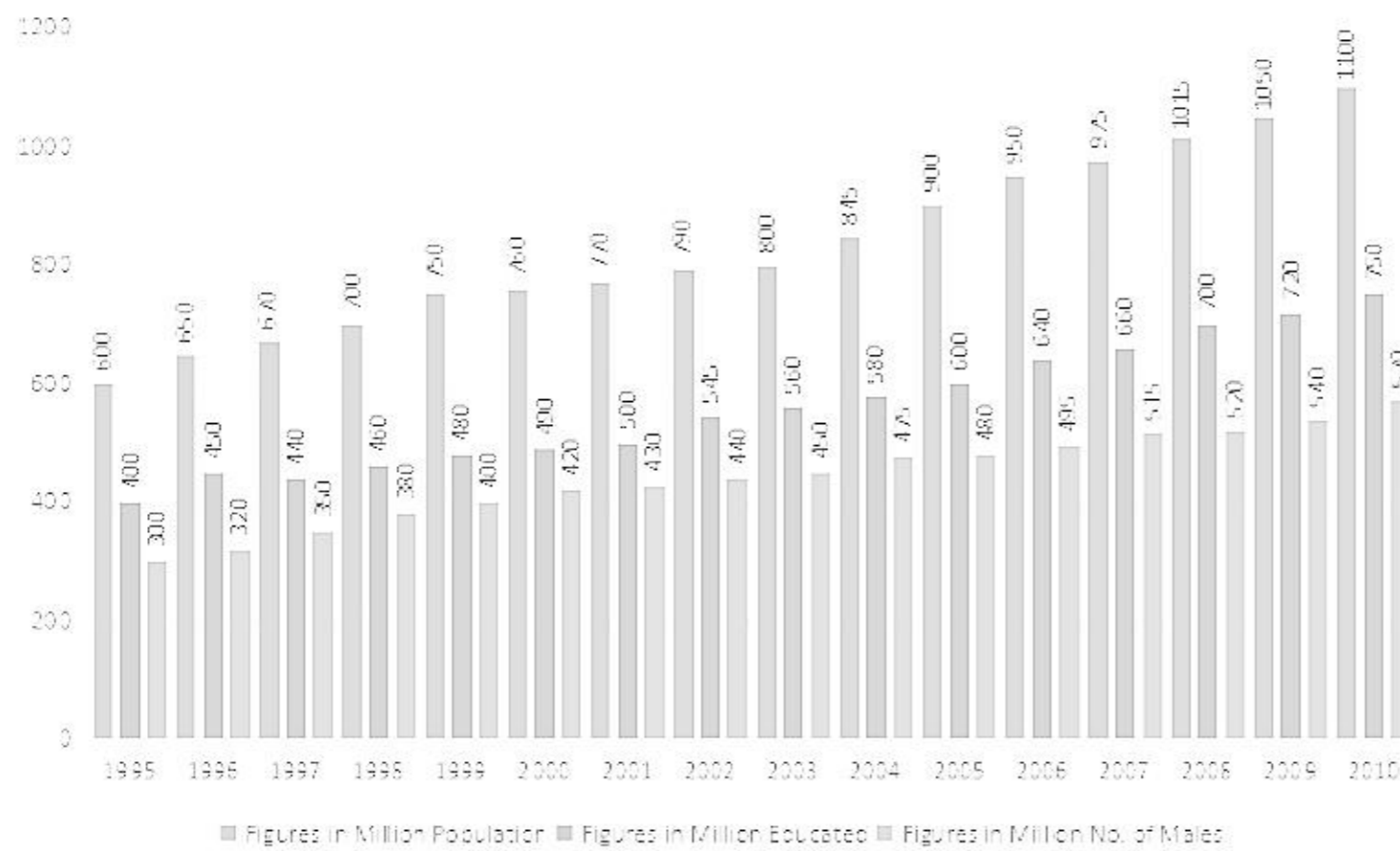

Question 63

In which year the percentage increase in the number of females over the previous year is highest?

- A 1996
- B 1999
- C 2004
- D 2005

Answer: D

Explanation:

We know that, female population = Total population - Male population.

Therefore, the percentage increase in Female population in 1996 = $\frac{(650-320) - (600-300)}{(600-300)} \times 100 = 10\%$

The percentage increase in Female population in 1999 = $\frac{(750-400) - (700-380)}{(700-380)} \times 100 = 9.37\%$

The percentage increase in Female population in 2004 = $\frac{(845-475) - (800-450)}{(800-450)} \times 100 = 5.71\%$

The percentage increase in Female population in 2005 = $\frac{(900-480) - (845-475)}{(845-475)} \times 100 = 13.51\%$

Hence, option D is the correct answer.

Question 64

In 2002 if the ratio of number of educated male to professionally educated female was 5:4. If the number of educated males increased by 25% in 2003. What is the percentage change in number of uneducated females in 2003?

- A +25%
- B +30%
- C +34%
- D +56%

Answer: D

Explanation:

Number of female in the year 2002 = 790 - 440 = 350 million.

Number of educated females in the year 2002 = $\frac{4}{9} \times 545 \approx 242$ millions

Hence, total number of uneducated females in the year 2002 = $350 - 242 = 108$ millions ... (1)

Number of educated males in the year 2002 = $\frac{5}{9} \times 545 \approx 303$ millions.

Therefore, the number of educated males in the year 2003 = $1.25 \times 303 = 378.75$ millions.

Hence, the number of educated females in the year 2003 = Total educated population - the number of educated males = $560 - 378.75 \approx 181.25$ millions.

Total number of uneducated females in the year 2003 = Total number of females - the number of educated females = $(800 - 450) - 181 = 169$ millions. ... (2)

From equation (2) and (1), we can say that the percentage change in number of uneducated females in 2003 = $\frac{169 - 108}{108} \times 100 \approx 56$ percent. Hence, we can say that option D is the correct answer.

Download IIFT Previous Papers PDF

Question 65

In year 2005 total population living in urban area is equal to sixty eight percent of educated population. The ratio of number of people living in urban area to people living in rural area is 43:12 in 2010. What is the ratio of the rural population in 2005 to that in 2010?

- A 0.8
- B 0.47
- C 2.05
- D None

Answer: C

Explanation:

In year 2005 total population living in urban area is equal to sixty eight percent of educated population. The ratio of number of people living in urban area to people living in rural area is 43:12 in 2010. What is the ratio of the rural population in 2005 to that in 2010?

Total population living in urban area in the year 2005 = $0.68 \times 600 = 408$ millions.

Therefore, the population living in rural area in the year 2005 = $900 - 408 = 492$ millions.

It is given the the ratio of number of people living in urban area to people living in rural area is 43:12 in 2010.

Hence, the number of people living in rural area in the year 2010 = $\frac{12}{55} \times 1100 = 240$ millions.

Therefore, the required ratio = $492/240 = 2.05$.

Download IIFT GK PDFs

Section 3 part 1

Instructions

Kodak decided that traditional film and prints would continue to dominate through the 1980s and that photo finishers, film retailers, and, of course, Kodak itself could expect to continue to occupy their long-held positions until 1990. Kodak was right and wrong. The quality of digital cameras greatly improved. Prices plunged because the cameras generally followed Moore's Law, the famous prediction by Intel co-founder Gordon Moore in the 1960s that the cost of a unit of computing power would fall by 50 percent every eighteen to twenty-four months. Cameras began to be equipped with what the industry called removable media - those little cards that hold the pictures - so pictures were easier to print or to move to other devices, such as computers. Printers improved. Their costs dropped, too. The Internet caught the popular imagination, and people began e-mailing each other pictures rather than print them. Kodak did little to ready itself for the onslaught of digital technology because it consistently tried to hold on to the profits from its old technology and underestimated the speed with which the new would take hold. Kodak decided it could use digital technology to enhance film, rather than replace it. Instead of preparing for the digital world, Kodak headed off in a direction that cost it dearly. In 1988, Kodak bought Sterling Drug for \$5.1 billion. Kodak had decided it was really a chemicals business, not a photography company. So, Kodak reasoned, it should move into adjacent chemical markets, such as drugs. Well, chemically treated photo paper really isn't that similar to hormonal agents and cardiovascular drugs. The customers are different. The delivery channels are different. Kodak lost its shirt. It sold Sterling in pieces in 1994 for about half the original purchase price. George M. C. Fisher was the new CEO of Kodak in 1993. Fisher's solution was to hold on to the film business as long as possible, while adding a technological veneer to it. For instance, he introduced the Advantix Preview camera, a hybrid of digital

and film technology. Users took pictures the way they always had, and the images were captured on film. Kodak spent more than \$500 million developing Advantix, which flopped.

Fisher also tried to move Kodak's traditional retail photo-processing systems into digital world and in this regard installed tens of thousands of image magic kiosks. These kiosks came just as numerous companies introduced inexpensive, high-quality photo printers that people could use at home, which, in fact, is where customers preferred to view their images and fiddle with them. Fisher also tried to insert Kodak as an intermediary in the process of sharing images electronically. He formed partnerships that let customers receive electronic versions of their photos by e-mail and gave them access to kiosks that let them manipulate and reproduce old photographs. You don't need Kodak to upload photos to your computer and e-mail them. Fisher also formed a partnership with AOL called "You've Got Pictures." Customers would have their film developed and posted online, where friends and family could view them. Customers would pay AOL \$7 for this privilege, on top of the \$9 paid for photo processing. However sites like Snapfish were allowing pictures to be posted online free. Fisher promised early on, that Kodak's digital-photography business would be profitable by 1997. It wasn't. In 1997 Philippe Kahn led the advent of cell phone camera. With the cell phone camera market growth Kodak didn't just lose out on more prints. The whole industry lost out on sales of digital cameras, because they became just a feature that was given away free on cell phones. Soon cameras became a free feature on many personal computers, too. What had been so profitable for Kodak for so long- capturing images and displaying them- was going to become essentially free.

In 1999 Fisher resigned and Carp became the new CEO. In 2000, Carp's first year as CEO, profit was about flat, at \$1.41 billion. Carp, too, retired early, at age fifty-seven. Carp had pursued Fisher's basic strategy of "enhancing" the film business to make it last as long as possible, while trying to figure out some way to get recurring revenue from the filmless, digital world. But the temporizing didn't work any better for Carp than it had for Fisher. Kodak talked, for instance, about getting customers to digitize and upload to the Internet more of the 300 million rolls of film that Kodak processed annually, as of 2000. Instead, customers increasingly skipped the film part. In 2002, sales of digital cameras in the United States passed those of traditional cameras-even though Kodak in the mid-1990s had projected that it would take twenty years for digital technology to eclipse film. The move to digital in the 2000s happened so fast that, in 2004, Kodak introduced a film camera that won a "camera of the year" award, yet was discontinued by the time Kodak collected the award. Kodak staked out a position as one of the major sellers of digital cameras, but being "one of" is a lot different from owning 70 percent to 80 percent of a market, as Kodak had with film, chemicals, and processing. In 2002 competition in the digital market was so intense that Kodak lost 75 percent of its stock- market value over the past decade, falling to a level about half of what it was when the reporter suggested to Carp that he might sell the company. As of 2005, Kodak employed less than a third of the number who worked for it twenty years earlier. To see what might have been, look at Kodak's principal competitors in the film and paper markets. Agfa temporized on digital technology, then sold its film and paper business to private-equity investors in 2004. The business went into bankruptcy proceedings the following year, but that wasn't Agfa's problem. It had cashed out at a halfway reasonable price.

Question 66

As per the passage which of the following statements truly reflects the real theme of the passage?

- A Moore's law predicted that cost per unit of computing power would exhibit a standard deviation of 25% per annum.
- B Popularity of removable media and internet lead to high demand for computers.
- C Kodak managers were able to predict the flow of digital technology and their critical value drivers.
- D Kodak did not have a vision to plough back the profits from old technology to research and development in new technology.

Answer: D

Explanation:

Throughout the passage, the author's ideas revolve around the fact that Kodak did not embrace new technology which led to its downfall. Hence, option D is the correct answer.

IIFT Free Topic-Wise Important Questions (Study Material)

Question 67

Which of the following statements is not true?

- I. Kodak bought sterling drug as a strategic choice for a chemical business as it was already in the business of chemically treated photo paper.
- II. The chemical business was in sync with the existing business of Kodak running across the customer segment, delivery channels and the regulatory environment.
- III. Kodak committed a mistake by selling sterling in pieces at a loss of 50%.
- IV. Kodak's diversification attempt with purchase of sterling to strengthen its core business and shift to digital world was a shift from its strategic focus.

- A Only I and II
- B Only II and III
- C Only III and IV
- D Only I, II, III

Answer: B

Explanation:

From the first paragraph, we can infer that statements I and IV are true. Hence, option B is the correct answer.

Question 68

Kodak lost a big piece of its market share to its competitors because of the following best explained reason.

- I. When Carp became the CEO the digital Technology eclipsed film technology business and further Carp had been with the company for twenty nine years and had no background in technology.
- II. Carp in 2004 introduced a film camera that won camera of the year award, yet it was discontinued by the time Kodak collected the award.
- III. Kodak moved from traditional retail photo processing systems into digital world installing several thousands of image magic kiosks that failed to deliver real benefits to the customers.
- IV. Phillipe Kahn led the advent of cell phone camera and Kodak lost out on the print business and ability to share images became a free feature with no additional charge.

- A I and II
- B II and III
- C I and IV
- D III and IV

Answer: D

Explanation:

"Fisher also tried to move Kodak's traditional retail photo-processing systems into digital world and in this regard installed tens of thousands of image magic kiosks. These kiosks came just as numerous companies introduced inexpensive, high-quality photo printers that people could use at home, which, in fact, is where customers preferred to view their images and fiddle with them." - from these lines, statement III can be inferred.

"In 1997 Philippe Kahn lead the advent of cell phone camera. With the cell phone camera market growth Kodak didn't just lose out on more prints. The whole industry lost out on sales of digital cameras, because they became just a feature that was given away free on cell phones. Soon cameras became a free feature on many personal computers, too. What had been so profitable for Kodak for so long- capturing images and displaying them- was going to become essentially free" - from these lines, statement IV can be inferred.

Hence, option D is the correct answer.

Question 69

Arrange the given statements in the correct sequence as they appear in the passage.

- I. Kodak lost to its competitors a big pie of its market share.
- II. Kodak ventured into chemical business to strengthen its digital technology business.
- III. Kodak downsized its workforce drastically.
- IV. Kodak tied up with business firms for photo processing.

- A I, II, III, IV
- B III, IV, II, I
- C II, IV, I, III
- D I, III, II, IV

Answer: C

Explanation:

- Statement II - para 1
- Statement IV - para 2
- Statement I - para 3
- Statement III - para 3

Hence, option C is the correct answer.

Top 500+ Free Questions for IIFT

Question 70

Match the following

1	Intel	a.	Preview cameras that helped users to immediately see the pictures taken
2	Fisher	b.	Photo processing, developing and posting online photos
3	AOL	c.	Lead to insolvency of digital technology business
4	Agfa	d.	Price of technology product reduces to half every year or two

- A 1-d, 2-a, 3-b, 4-c
- B 1-a, 2-d, 3-c, 4-b
- C 1-c, 2-b, 3-a, 4-d
- D 1-d, 2-c, 3-a, 4-b

Answer: A

Explanation:

1 ----> 'd' - "Prices plunged because the cameras generally followed Moore's Law, the famous prediction by Intel co-founder Gordon Moore in the 1960s that the cost of a unit of computing power would fall by 50 percent every eighteen to twenty-four months."

2 ----> 'a' - "Fisher's solution was to hold on to the film business as long as possible, while adding a technological veneer to it. For instance, he introduced the Advantix Preview camera, a hybrid of digital and film technology. Users took pictures the way they always had, and the images were captured on film. Kodak spent more than \$500 million developing Advantix, which flopped."

3 ----> 'b' - "Fisher also formed a partnership with AOL called 'You've Got Pictures.' Customers would have their film developed and posted online, where friends and family could view them. Customers would pay AOL \$7 for this privilege, on top of the \$9 paid for photo processing. However sites like Snapfish were allowing pictures to be posted online free."

4 ----> 'c' - 'Agfa temporized on digital technology, then sold its film and paper business to private-equity investors in 2004. The business went into bankruptcy proceedings the following year, but that wasn't Agfa's problem. It had cashed out at a halfway reasonable price.'

Hence, option A is the correct answer.

Instructions

People are continually enticed by such "hot" performance, even if it lasts for brief periods. Because of this susceptibility, brokers or analysts who have had one or two stocks move up sharply, or technicians who call one turn correctly, are believed to have established a credible record and can readily find market followings. Likewise, an advisory service that is right for a brief time can beat its drums loudly. Elaine Garzarelli gained near immortality when she purportedly "called" the 1987 crash. Although, as the market strategist for Shearson Lehman, her forecast was never published in a research report, nor indeed communicated to its clients, she still received widespread recognition and publicity for this call, which was made in a short TV interview on CNBC. Still, her remark on CNBC that the Dow could drop sharply from its then 5300 level rocked an already nervous market on July 23, 1996. What had been a 40-point gain for the Dow turned into a 40-point loss, a good deal of which was attributed to her comments.

The truth is, market-letter writers have been wrong in their judgments far more often than they would like to remember. However, advisors understand that the public considers short-term results meaningful when they are, more often than not, simply ch...

public eye usually gain large numbers of new subscribers for being right by random luck. Which brings us to another important probability error that falls under the broad rubric of representativeness. Amos Tversky and Daniel Kahneman call this one the "law of small numbers.". The statistically valid "law of large numbers" states that large samples will usually be highly representative of the population from which they are drawn; for example, public opinion polls are fairly accurate because they draw on large and representative groups. The smaller the sample used, however (or the shorter the record), the more likely the findings are chance rather than meaningful. Yet the Tversky and Kahneman study showed that typical psychological or educational experimenters gamble their research theories on samples so small that the results have a very high probability of being chance. This is the same as gambling on the single good call of an advisor. The psychologists and educators are far too confident in the significance of results based on a few observations or a short period of time, even though they are trained in statistical techniques and are aware of the dangers.

Note how readily people over generalize the meaning of a small number of supporting facts. Limited statistical evidence seems to satisfy our intuition no matter how inadequate the depiction of reality. Sometimes the evidence we accept runs to the absurd. A good example of the major overemphasis on small numbers is the almost blind faith investors place in governmental economic releases on employment, industrial production, the consumer price index, the money supply, the leading economic indicators, etc. These statistics frequently trigger major stock- and bond-market reactions, particularly if the news is bad. Flash statistics, more times than not, are near worthless. Initial economic and Fed figures are revised significantly for weeks or months after their release, as new and "better" information flows in. Thus, an increase in the money supply can turn into a decrease, or a large drop in the leading indicators can change to a moderate increase. These revisions occur with such regularity you would think that investors, particularly pros, would treat them with the skepticism they deserve. Alas, the real world refuses to follow the textbooks. Experience notwithstanding, investors treat as gospel all authoritative-sounding releases that they think pinpoint the development of important trends. An example of how instant news threw investors into a tailspin occurred in July of 1996. Preliminary statistics indicated the economy was beginning to gain steam. The flash figures showed that GDP (gross domestic product) would rise at a 3% rate in the next several quarters, a rate higher than expected. Many people, convinced by these statistics that rising interest rates were imminent, bailed out of the stock market that month. To the end of that year, the GDP growth figures had been revised down significantly (unofficially, a minimum of a dozen times, and officially at least twice). The market rocketed ahead to new highs to August 1997, but a lot of investors had retreated to the sidelines on the preliminary bad news. The advice of a world champion chess player when asked how to avoid making a bad move. His answer: "Sit on your hands". But professional investors don't sit on their hands; they dance on tiptoe, ready to flip after the least particle of information as if it were a strongly documented trend. The law of small numbers, in such cases, results in decisions sometimes bordering on the inane. Tversky and Kahneman's findings, which have been repeatedly confirmed, are particularly important to our understanding of some stock market errors and lead to another rule that investors should follow.

Question 71

Which statement does not reflect the true essence of the passage?

- I. Tversky and Kahneman understood that small representative groups bias the research theories to generalize results that can be categorized as meaningful result and people simplify the real impact of passable portray of reality by small number of supporting facts.
- II. Governmental economic releases on macroeconomic indicators fetch blind faith from investors who appropriately discount these announcements which are ideally reflected in the stock and bond market prices.
- III. Investors take into consideration myopic gain and make it meaningful investment choice and fail to see it as a chance of occurrence.
- IV. Irrational overreaction to key regulators expressions is same as intuitive statistician stumbling disastrously when unable to sustain spectacular performance.

- A Only I
- B Only IV
- C II and IV
- D Only III

Answer: C

Explanation:

Statements I and III capture the true essence of the passage. Statements II and IV are the supporting ideas to strengthen the main idea.

Government economic release in the passage is not the main point which author makes in the passage.

"irrational overreaction to key regulators" is used to elaborate the idea but is not the main point of the author.

Hence, option C is the correct answer.

Question 72

The author of the passage suggests the anomaly that leads to systematic errors in predicting future. Which of the following statements does not best describe the anomaly as suggested in the passage above?

- I. The psychological pressures account for the anomalies just like soothsayers warning about the doomsday and natural disasters and market crashes.
- II. Contrary to several economic and financial theories investors are not good intuitive statisticians, especially under difficult conditions and are unable to calculate the odds properly when making investment choices.
- III. Investors are swamped with information and they react to this avalanche of data by adopting shortcuts or rules of thumb rather than formally calculating odds of a given outcome.
- IV. The distortions produced by subjectively calculated probabilities are large, systematic and difficult to eliminate even when investors are fully aware of them.

- A Only I
- B Only IV
- C I and III
- D II and IV

Answer: C

Explanation:

The passage blames 'law of small numbers' as the culprit behind the poor decision making of the investors. Statements II and IV describe the same.

Hence, option C is the correct answer.

Download IIFT Syllabus PDF

Question 73

"Tversky and Kahneman's findings ... lead to another rule that investors should follow". Which rule is the author talking about?

- I. Not to be influenced by short term and occasional record of a money manager, broker, analysts, or advisor, no matter how impressive.
- II. To accept cursory economic or investment news without significant substantiation but supported by statistical evidence even if limited in data sufficiency.
- III. In making decisions we become overly immersed in the details of a particular situation and consider all the outcomes of similar experience in our past.
- IV. None of the above.

- A Only IV
- B Only I
- C Only III
- D I, II, and III

Answer: B

Explanation:

"Amos Tversky and Daniel Kahneman call this one the 'law of small numbers.'. The statistically valid 'law of large numbers' states that large samples will usually be highly representative of the population from which they are drawn; for example, public opinion polls are fairly accurate because they draw on large and representative groups. The smaller the sample used, however (or the shorter the record), the more likely the findings are chance rather than meaningful. Yet the Tversky and Kahneman study showed that typical psychological or educational experimenters gamble their research theories on samples so small that the results have a very high probability of being chance." Statement I is what the author is talking about.

Hence, option B is the correct answer.

Question 74

According to the passage which statement written below is farthest in explaining the meaning of the passage above?

- I. Market letter writers have been wrong in their judgments many a times but they continue to express their opinion as dramatic predictions and well time call results in huge rewards to analysts, journalist and popular writers.
- II. Public opinion polls are fairly accurate because they are based on randomly selected diminutive representative groups and hence are more meaningful than intuitive statistics of an outcome.
- III. People generally limit the need for hefty statistical evidence as it satisfies their intuition without reflecting the reality.
- IV. None of the above.

- A Only IV
- B Only II
- C II and III
- D Only I

Answer: B

Explanation:

Instructions

When people react to their experiences with particular authorities, those authorities and the organizations or institutions that they represent often benefit if the people involved begin with high levels of commitment to the organization or institution represented by the authorities. First, in his studies of people's attitudes toward political and legal institutions, Tyler found that attitudes after an experience with the institution were strongly affected by prior attitudes. Single experiences influence post-experience loyalty but certainly do not overwhelm the relationship between pre-experience and post-experience loyalty. Thus, the best predictor of loyalty after an experience is usually loyalty before that experience. Second, people with prior loyalty to the organization or institution judge their dealings with the organization's or institution's authorities to be fairer than do those with less prior loyalty, either because they are more fairly treated or because they interpret equivalent treatment as fairer.

Although high levels of prior organizational or institutional commitment are generally beneficial to the organization or institution, under certain conditions high levels of prior commitment may actually sow the seeds of reduced commitment. When previously committed individuals feel that they were treated unfavorably or unfairly during some experience with the organization or institution, they may show an especially sharp decline in commitment. Two studies were designed to test this hypothesis, which, if confirmed, would suggest that organizational or institutional commitment has risks, as well as benefits. At least three psychological models offer predictions of how individuals' reactions may vary as a function of a: their prior level of commitment and b: the favorability of the encounter with the organization or institution. Favorability of the encounter is determined by the outcome of the encounter and the fairness or appropriateness of the procedures used to allocate outcomes during the encounter. First, the instrumental prediction is that because people are mainly concerned with receiving desired outcomes from their encounters with organizations, changes in their level of commitment will depend primarily on the favorability of the encounter. Second, the assimilation prediction is that individuals' prior attitudes predispose them to react in a way that is consistent with their prior attitudes.

The third prediction, derived from the group-value model of justice, pertains to how people with high prior commitment will react when they feel that they have been treated unfavorably or unfairly during some encounter with the organization or institution. Fair treatment by the other party symbolizes to people that they are being dealt with in a dignified and respectful way, thereby bolstering their sense of self-identity and self-worth. However, people will become quite distressed and react quite negatively if they feel that they have been treated unfairly by the other party to the relationship. The group-value model suggests that people value the information they receive that helps them to define themselves and to view themselves favorably. According to the instrumental viewpoint, people are primarily concerned with the more material or tangible resources received from the relationship. Empirical support for the group-value model has implications for a variety of important issues, including the determinants of commitment, satisfaction, organizational citizenship, and rule following. Determinants of procedural fairness include structural or interpersonal factors. For example, structural determinants refer to such things as whether decisions were made by neutral, fact-finding authorities who used legitimate decision-making criteria. The primary purpose of the study was to examine the interactive effect of individuals a: commitment to an organization or institution prior to some encounter and b: perceptions of how fairly they were treated during the encounter, on the change in their level of commitment. A basic assumption of the group-value model is that people generally value their relationships with people, groups, organizations, and institutions and therefore value fair treatment from the other party to the relationship. Specifically, highly committed members should have especially negative reactions to feeling that they were treated unfairly, more so than a: less-committed group members or b: highly committed members who felt that they were fairly treated.

The prediction that people will react especially negatively when they previously felt highly committed but felt that they were treated unfairly also is consistent with the literature on psychological contracts. Rousseau suggested that, over time, the members of work organizations develop feelings of entitlement, i.e., perceived obligations that their employers have toward them. Those who are highly committed to the organization believe that they are fulfilling their contract obligations. However, if the organization acted unfairly, then

highly committed individuals are likely to believe that the organization did not live up to its end of the bargain.

Question 75

The hypothesis mentioned in the passage tests at least one of the following ideas.

- A People continue to show loyalty only if they were initially committed to the organization.
- B Our experiences influence post-experience loyalty but certainly underwhelm the relationship between pre-experience and post-experience loyalty.
- C Pre-experience commitment always has inverse relationship with the post-experience commitment.
- D None of these ideas are being tested by the hypothesis.

Answer: B

Explanation:

First, the instrumental prediction is that because people are mainly concerned with receiving desired outcomes from their encounters with organizations, changes in their level of commitment will depend primarily on the favorability of the encounter. Option B is the most relevant.

Option C is wrong because the second paragraph mentions cases where experiences influenced post experience loyalty both positively and negatively.

Option A is incorrect as the passage clearly states that the post experience loyalty depends upon the fairness of the experience.

Hence, Option B is the correct answer.

Quant Formulas for IIFT PDF

Question 76

There is only one term in the left column which matches with the options given in the second column. Identify the correct pair from the following table:

a.	Instrumental	1	Better outcome leads to more
b.	Assimilation	2	Prior belief is instrumental in deciding about the post encounter commitment.
c.	Group-value	3	Sense of value gets jeopardized that leads to negative attitude.
d.	Institutional	4	Deals mainly with tangible outcomes.

- A a-1 and 4
- B b-3 and 4
- C c-2 and 4
- D d-1 only

Answer: A

Explanation:

First, the instrumental prediction is that because people are mainly concerned with receiving desired outcomes from their encounters with organizations, changes in their level of commitment will depend primarily on the favorability of the encounter. - a matches with 1.

According to the instrumental viewpoint, people are primarily concerned with the more material or tangible resources received from the relationship. - a matches with 4.

Hence, option A is the correct answer.

Question 77

For summarizing the passage, which of the following is most appropriate:

- A The study explored how citizens' commitment to legal authorities changed as a function of their initial level of commitment and their perceptions of how fairly they were treated in their recent encounters with legal authorities.
- B The influence of individuals' prior commitment to an institution on their reactions to the perceived fairness of decisions rendered by the institution was examined.
- C Given the generally positive consequences to organizations of having committed employees, it may be that unfair managerial practices would begin to alienate the very employees that the organization would least wish to alienate.
- D The passage aims at understanding how people define happiness and these definitions include instrumental view-points.

Answer: B

Explanation:

Instructions

In the annals of investing, Warren Buffett stands alone. Starting from scratch, simply by picking stocks and companies for investment, Buffett amassed one of the epochal fortunes of the twentieth century. Over a period of four decades more than enough to iron out the effects of fortuitous rolls of the dice, Buffett outperformed the stock market, by a stunning margin and without taking undue risks or suffering a single losing year. Buffett did this in markets bullish and bearish and through economies fat and lean, from the Eisenhower years to Bill Gates, from the 1950s to the 1990s, from saddle shoes and Vietnam to junk bonds and the information age. Over the broad sweep of postwar America, as the major stock averages advanced by 11 percent or so a year, Buffett racked up a compounded annual gain of 29.2 percent. The uniqueness of this achievement is more significant in that it was the fruit of old-fashioned, long-term investing. Wall Street's modern financiers got rich by exploiting their control of the public's money: their essential trick was to take in and sell out the public at opportune moments. Buffett shunned this game, as well as the more venal excesses for which Wall Street is deservedly famous. In effect, he rediscovered the art of pure capitalism, a cold-blooded sport, but a fair one. Buffett began his career, working out his study in Omaha in 1956. His grasp of simple verities gave rise to a drama that would recur throughout his life. Long before those pilgrimages to Omaha, long before Buffett had a record, he would stand in a corner at college parties, baby-faced and bright-eyed, holding forth on the universe as a dozen or two of his older, drunken fraternity brothers crowded around. A few years later, when these friends had metamorphosed into young associates starting out on Wall Street, the ritual was the same. Buffett, the youngest of the group, would plop himself in a big, broad club chair and expound on finance while the others sat at his feet. On Wall Street, his homespun manner made him a cult figure. Where finance was so forbiddingly complex, Buffett could explain it like a general-store clerk discussing the weather. He never forgot that underneath each stock and bond, no matter how arcane, there lay a tangible, ordinary business. Beneath the jargon of Wall Street, he seemed to unearth a street from small-town America. In such a complex age, what was stunning about Buffett was his applicability. Most of what Buffett did was imitable by the average person (this is why the multitudes flocked to Omaha). It is curious irony that as more Americans acquired an interest in investing, Wall Street became more complex and more forbidding than ever. Buffett was born in the midst of depression. The depression cast a long shadow on Americans, but the post war prosperity eclipsed it. Unlike the modern portfolio manager, whose mind-set is that of a trader, Buffett risked his capital on the long term growth of a few select businesses. In this, he resembled the magnates of a previous age, such as J P Morgan Sr.

As Jack Newfield wrote of Robert Kennedy, Buffett was not a hero, only a hope; not a myth, only a man. Despite his broad wit, he was strangely stunted. When he went to Paris, his only reaction was that he had no interest in sight-seeing and that the food was better in Omaha. His talent sprang from his unrivaled independence of mind and ability to focus on his work and shut out the world, yet those same qualities exacted a toll. Once, when Buffett was visiting the publisher Katharine Graham on Martha's Vineyard, a friend remarked on the beauty of the sunset. Buffett replied that he hadn't focused on it, as though it were necessary for him to exert a deliberate act of concentration to "focus" on a sunset. Even at his California beachfront vacation home, Buffett would work every day for weeks and not go near the water. Like other prodigies, he paid a price. Having been raised in a home with more than its share of demons, he lived within an emotional fortress. The few people who shared his office had no knowledge of the inner man, even after decades. Even his children could scarcely recall a time when he broke through his surface calm and showed some feeling. Though part of him is a showman or preacher, he is essentially a private person. Peter Lynch, the mutual-fund wizard, visited Buffett in the 1980s and was struck by the tranquility in his inner sanctum. His archives, neatly alphabetized in metal filing cabinets, looked as files had in another era. He had no armies of traders, no rows of electronic screens, as Lynch did. Buffett had no price charts, no computer - only a newspaper clipping from 1929 and an antique licker under a glass dome. The two of them paced the floor, recounting their storied histories, what they had bought, what they had sold. Where Lynch had kicked out his losers every few weeks, Buffett had owned mostly the same few stocks for years and years. Lynch felt a pang, as though he had traveled back in time. Buffett's one concession to modernity is a private jet. Otherwise, he derives little pleasure from spending his fabulous wealth. He has no art collection or snazzy car, and he has never lost his taste for hamburgers. He lives in a commonplace house on a tree-lined block, on the same street where he works. His consuming passion - and pleasure - is his work, or, as he calls it, his canvas. It is there that he revealed the secrets of his trade, and left a self-portrait.

Question 78

"Saddle shoes and Vietnam", as expressed in the passage, refers to:

- I. Denier cri and Vietnam war
- II. Growth of leather footwear industry and Vietnam shoe controversy
- III. Modern U.S. population and traditional expatriates
- IV. Industrial revolution and Vietnam Olympics
- V. Fashion and Politics

- A I and V
- B II and IV
- C III and V
- D II and III

Answer: A

Explanation:

Saddle shoes in the passage refers to profligacy. Deneir cri means latest fashion. Therefore, I and V are relevant. Hence, option A is the correct answer.

IIFT Free Preparation App

Question 79

Identify the correct sequence:

- I. Depression -> Eisenhower -> Microsoft
- II. California -> New York -> Omaha
- III. J.P.Morgan -> Buffett -> Bill Gates
- IV. Mutual funds -> Hedge funds -> Brokers

- A I and II
- B I and III
- C II and IV
- D III and IV

Answer: B

Explanation:

Buffett was born during depression. Eisenhower years were in 1950s and Microsoft became famous during 1990s. Morgan was senior to Buffett and Bill Gates junior to Buffett. Hence, option A is the correct answer.

Question 80

Choose the most appropriate answer: according to the author, Warren Buffett was

- I. Simple and outmoded
- II. Against planned economy and technology
- III. Deadpan
- IV. Spiritually raw

- A I and IV
- B II and IV
- C III and IV

D I and III

Answer: D

Explanation:

From the line 'Buffett's one concession..... privet ' we can infer that Warren Buffet is old fashioned. Also he lives in a ordinary house which shows that he is a simple man. When he visited Paris, he had no interest in sight-seeing. On the beauty of sunset, he remarked that he had not focused on it. He rarely showed any feeling. All these inferences show that Warren is a deadpan. However from the passage, we cannot conclude that he was against planned economy. Similarly, nothing can be said about his spiritual life. Hence D is the answer.

Download General Science Notes for IIFT PDF

Section 3 part 2

Instructions

From the given pair of words select the most appropriate pair that fills the gaps and makes the sentence more meaningful.

Question 81

These issues are extremely _____ and any knee jerk reaction will ultimately result in a loss of _____ for all shareholders.

- A Unassociated, curare
- B Ambiguous, plutocracy
- C Nuanced, opportunity
- D Contexed, serendipity

Answer: C

Take 3 Free CAT Mocks (With Solutions)

Question 82

Growth under this government has been _____ high and remarkably _____ even during the worst global economic crisis.

- A Impededly, flippant
- B Relatively, intractable
- C Obstructedly, rigid
- D Sustainedly, resilient

Answer: D

Question 83

There are different and _____ versions about what happened in the city, but one thing is certain: it is a dastardly act that must be condemned _____

- A Dissimilar, concertedly
- B Contrary, obviously
- C Conflicting, unequivocally
- D Unique, without conflict

Answer: C

Question 84

They _____ their seats away from the curved wall panels to give themselves more space as the flight attendant brought drinks from the gallery, which was _____ with family's favorite snacks and beverages.

- A Swiveled, stocked
- B Hinged, lacquered
- C Pended, embellished
- D Retracted, thronged

Answer: A

XAT Previous Papers

Question 85

Cairn cannot _____ bring into picture some _____ outsider which has little experience and necessary consents to deal in the oil field.

- A Peremptorily, ascribed
- B Complaisantly, endorsed
- C Democratically, aberrant
- D Arbitrarily, unrelated

Answer: D

Question 86

Economic growth is on auto-pilot, unlikely to be derailed by any lapse into _____ and controls or to be _____ by serious policy reforms.

- A Growth, blowed
- B Boom, berated
- C Recession, reduced
- D Dirigisme, boosted

Answer: D

Instructions

Each sentence has a part which is underlined. Beneath the sentence you will find four ways of phrasing the underlined part. Follow the requirements of the standard written English to choose your answer. Selection should make the sentence clear, exact and free of grammatical error. It should minimize awkwardness, ambiguity and redundancy.

Question 87

Large and experienced firms are more efficient at acquiring smaller and distressed firms than are large and inexperienced firms, and converting them to profitable ventures.

- A Large and experienced firms are more efficient at acquiring smaller and distressed firms than large and inexperienced firms
- B Large and experienced firms are more efficient than large and inexperienced firms at acquiring smaller and distressed firms
- C Large and experienced firms, acquire smaller and distressed firms more efficiently than large and inexperienced firms

- D Large and experienced firms, more efficient than large and inexperienced firms at acquiring smaller and distressed firms

Answer: B

CMAT Free Solved Previous Papers.

Question 88

The economic growth increased from 7 to 9 per cent in November 2010, supporting the expectations that industrial growth rate in October-December quarter more than doubled that of the 4 per cent growth rate in industrial growth for the previous quarter.

- A that industrial growth in the October- December quarter more than doubled that of
- B of industrial growth in the October- December quarter, that it more than doubled
- C of industrial growth in the October- December quarter, that it would more than double that of
- D that industrial growth in October-December quarter would more than double

Answer: D

Question 89

As a result of surging financial greed, the international rating agencies upgraded the rating of the credit derivative instruments, and hence analysts recommended a strong buy, ignoring the advice of Warren Buffett who warned that these instruments would prove not only dangerous but ineffective in the long run.

- A who warned that these instruments would prove to be both dangerous and
- B warning that these instruments would prove not only dangerous and also
- C warning that these instruments would prove itself to be both dangerous and
- D who was warning that these instruments would prove not only dangerous but

Answer: A

Instructions

From the given options identify the word pair which is unrelated to the given word pair.

Question 90

IMPUISSANCE: DESECRATE

- A Decrepit : Desolate
- B Effete : Sacrilege
- C Ornery : Contort
- D Bedraggled : Profanity

Answer: C

MAT Free Solved Previous Papers

Question 91

INSOUCIANT : GOSSAMER

- A Nymphs : Gehenna
- B Perfunctory : Diaphanous
- C Pococurante: Pellucid
- D Nonchalant : Tiffany

Answer: A

Instructions

Select the pair of wrongly spelt words from the given set of choices.

Question 92

- A Conscientious : Oleaginous
- B Obstreperous : Supercilious
- C Diletante : Reminiscence
- D Tergiversation : Interstice

Answer: C

Explanation:

Both the words in option C are incorrectly spelt.

Correct spelling for 1st word is 'Dilettante' which means a person who cultivates an area of interest, such as the arts, without real commitment or knowledge.

Correct spelling for 2nd word is 'Reminiscence' which means a story told about a past event remembered by the narrator.

Question 93

- A Irascible : Surreptitious
- B Proclivity : Vicissitude
- C Lassitude : Imperturbable
- D Munificent: Psusillanimous

Answer: D

Explanation:

Both the words in option D are incorrectly spelt.

Correct spelling for 1st word is 'Munificent' which means generous.

Correct spelling for 2nd word is 'Pusillanimous' which means timid or showing a lack of courage or determination.

PGDBA Previous Year Papers (Download PDF)PGDBA Previous Year Papers (Download PDF)

Instructions

Each question consists of a number of sentences that need to be properly sequenced, to form a meaningful and coherent paragraph/sentences. Choose the most logical order of sentences from the choices given below.

Question 94

- I. of course, it isn't anywhere near as simple as this in real life
- II. the diagram is commonly called 'the stack', and the people in the computer industry love to talk about it
- III. at the base are components that are assembled into finished hardware products; operating systems, middleware, and software applications sit above the hardware; and it's all topped off by a whole range of services
- IV. the stack shows most of the major pieces in a typical computing environment

- A II, I, III, IV
- B II, IV, III, I
- C III, IV, II, I
- D II, III, I, IV

The given passage talks about the diagram called stack and how it is organised.

Statement II introduces Stack.

Statement IV gives a basic overview of stack.

- E Statement III goes on to expand on statement IV. Hence Statements II, IV, III form a mandatory pair.

Statement I says that on paper Stack seems easy, however, in real life the implementation of Stack is difficult. The premise that Stack seems easy could be reached only after explaining the basics of stack. So Statement I is the last statement.

The correct order is II,IV,III,I.

Answer: B

Question 95

- I. as a skeptical empiricist,
- II. I do not want to be the turkey
- III. since we do not observe
- IV. so I do not want to focus
- V. solely on specific organs in the brain
- VI. brain functions very well

- A I, II, III, IV, V, VI
- B II, I, IV, III, V, VI
- C I, VI, IV, III, V, II
- D I, II, IV, V, III, VI

Answer: D

Question 96

- I. knowledge, even when it is exact
- II. because we tend to forget what we know
- III. if we do not pay attention
- IV. or forget how to process it properly
- V. does not often lead to appropriate actions
- VI. even when we are experts

- A I, V, II, IV, III, VI
- B I, V, III, IV, II, VI
- C VI, V, II, I, III, IV

D III, VI, I, II, V, IV

Answer: A

CAT Previous Papers PDF

Question 97

- I. in the classroom
- II. once they are let out on streets
- III. statisticians, it has been shown
- IV. and engage in most trivial inferential errors
- V. tend to leave their brains

A III, V, I, IV, II

B II, III, V, I, IV

C I, V, II, III, IV

D III, I, V, IV, II

Answer: A

Question 98

- I. sure enough failed
- II. I have tested myself and
- III. by carefully setting a wide range
- IV. even while consciously trying to be humble
- V. as we will see the core of my professional activities
- VI. and yet such underestimation happens to be

A I, II, V, III, IV, VI

B IV, II, I, III, V, VI

C V, II, I, IV, III, VI

D II, I, IV, III, VI, V

Answer: D

Question 99

- I. except that people got all excited
- II. so I would not have cared
- III. and talked quite a bit about
- IV. the least about them
- V. pouring verbal sauce around the forecasts
- VI. what these figures were going to mean

A I, II, IV, V, III, VI

B I, III, II, IV, V, VI

C II, IV, I, III, VI, V

D V, II, IV, VI, I, III

Answer: C

Take a XAT Free Mock Test

Instructions

For each of the following questions select the answer pair that expresses a relationship most similar to that expressed in the capitalized pair.

Question 100

OMNISCIENT : KNOWLEDGE::

- A Saturnine : energy
- B Boundless : expanse
- C Inquisitive : science
- D Complete : retraction

Answer: B

Explanation:

OMNISCIENT means knowing everything or "a third-person omniscient narrator". Hence, we can say that omniscient and knowledge are synonymous.

In similar manner, Boundless is related to expanse. Boundless means unlimited and expanse means a wide continuous area of something.

Hence, we can say option B is the correct answer.

Question 101

DISQUIETUDE : ANXIOUS::

- A Nonplus : perplexed
- B Cupidity : bellicose
- C Embellishment : overstated
- D Magnitude : unabridged

Answer: A

Question 102

DEVIATE : LECTURE::

- A Meander : drive
- B Disown : friend
- C Welcome : indifference
- D Entreat : solicitation

Answer: A

Take a CMAT free mock test

Question 103

NEBULOUS : FORM::

- A Insincere : misanthrope
- B Benevolent : excellence
- C Insipid : taste
- D Composed: innocence

Answer: C

Instructions

Select the correct sentence from the following.

Question 104

- A He made a blunder mistake.
- B I have learnt this lesson word by word.
- C She does not know swimming.
- D He got his daughter married.

Answer: D

Explanation:

In statement A, blunder mistake is an example of redundancy. It should be either 'He made a blunder' or 'He made a mistake'.

In statement B, it should be 'I have learnt this lesson word for word'.

In statement C, it should be 'She does not know how to swim'.

Only statement D doesn't have any error. Hence, option D is the correct answer.

Question 105

- A The average male investor expects to see all his investment stocks moving up, and they are often disappointed.
- B The people in my country are smarter than in other countries.
- C The number of failures of product in final quality inspection are increasing every year.
- D Before restructuring a firm, the CEO must consider the employees.

Answer: D

Explanation:

In statement A, "they" in second part is incorrect. It should be in accordance to the singular object present in first part of the sentence.

In statement B, it should be 'The people in my country are smarter than those in other countries.'.

In statement C, it should be 'The number of failures of product in the final quality inspection are increasing every year.'.

Only statement D doesn't have any error. Hence, option D is the correct answer.

Take a free SNAP mock test

Section 4

Instructions

For the following questions answer them individually

Question 106

Name the South Korean President who attended the Indian Republic Day Parade in 2010 as the chief guest.

- A Kim Yoon - Ok
- B Ban Ki- Moon
- C Lee Myung - Bak
- D Chung Mong Koo

Answer: C

Explanation:

The president of South Korea Lee Myung - Bak attended the Indian Republic Day Parade in 2010 as the chief guest. Hence, option C is the correct answer.

Take a NMAT free mock test

Question 107

The Indian government auctioned the 3G spectrum in 22 telecom circles in 2010. Which three companies won the maximum number of circles in the auction?

- a. R-Com
- b. Airtel
- c. Vodafone
- d. Aircel

- A a, b & c
- B b, c & d
- C a, c & d
- D a, b & d

Answer: D

Explanation:

R-Com, Airtel and Aircel won the maximum number of circles in the 3G spectrum auction. Hence, option D is the correct answer.

Question 108

Which one of the following group of banks formed a joint venture in Life Insurance Sector?

- A Canara Bank, HSBC, Oriental Bank of Commerce Limited
- B Canara Bank, HDFC, Syndicate Bank
- C HDFC, HSBC, Oriental Bank of Commerce Limited
- D Canara Bank, Axis Bank, HDFC

Answer: A

Explanation:

Canara Bank, HSBC, Oriental Bank of Commerce Limited formed a joint venture in Life Insurance Sector?.

Hence, option A is the correct answer.

Question 109

Match the International Organization-Location- Country

	International Organization		Location		Country
a.	North Atlantic Treaty Organization (NATO)	i.	Lyons	1	Austria
b.	World Wild Life fund (WWF)	ii.	Vienna	2	Switzerland
c.	Organization of Petroleum Exporting Countries (OPEC)	iii.	Gland	3	France
d.	International Police (INTERPOLE)	iv.	Brussels	4	Belgium

- A a-iii-2, b-iv-4, c-i-3, d-ii-1
- B a-iv-4, b-iii-2, c-ii-1, d-i-3
- C a-ii-4, b-iv-3, c-iii-1, d-i-2
- D a-i-4, b-iii-1, c-ii-3, d-iv-2

Answer: B

Explanation:

NATO's headquarter is in Brussels, Belgium.
 WWF's headquarter is in Gland, Switzerland.
 OPEC's headquarter is in Vienna, Austria.
 Interpol's headquarter is in Lyon, France.

Hence, option B is the correct answer.

Join MBA Telegram Group

Question 110

Match the Women CEOs in 2010 and their respective Company and its Location.

	Name of CEOs		Name of the Company		Location
a.	Carol A Bartz	i.	Dupont	1	Colorado
b.	Ellen J Kullman	ii.	Western Union	2	California
c.	Ursula Burns	iii.	Yahoo Inc	3	Connecticut
d.	Christina A Gold	iv.	Xerox Corporation	4	Deleware

- A a-ii-4, b-iii-3, c-iv-1, d-i-2
- B a-iii-3, b-iv-4, c-i-1, d-ii-2
- C a-iii-2, b-i-4, c-iv-3, d-ii-1
- D a-ii-1, b-iii-2, c-i-4, d-iv-3

Answer: C

Explanation:

Carol Bartz was the CEO of Yahoo based in California.
 Ellen J Kullman was the CEO of Dupont based in Delaware.
 Ursula Burns was the CEO of Xerox Corporation based in Connecticut.
 Christina A Gold is the CEO of Western Union based in Colorado.

Hence, option C is the correct answer.

Question 111

Match the Acquiring Company with its Target Company.

	Acquiring Company		Target Company
a.	United Breweries Group	i.	Schoneweiss
b.	Mahindra & Mahindra	ii.	RSM Ambit
c.	Price Water Cooper	iii.	Ambuja Cement
d.	Holcim	iv.	Shaw Wallace

A a-4, b-3, c-1, d-2

B a-1, b-4, c-2, d-3

C a-2, b-1, c-3, d-4

D a-4, b-1, c-2, d-3

Answer: D

Explanation:

United Breweries acquired Shaw Wallace.

Mahindra and Mahindra acquired Schoneweiss.

Price Water Cooper acquired RSM Ambit.

Holcim acquired Ambuja Cement.

Hence, option D is the correct answer.

Question 112

Match the Company and its Tagline

	Company		Tagline
a.	Toyota	1	Express Yourself
b.	BSNL	2	The easy way to stay in touch
c.	Airtel	3	Connecting India
d.	Trump (MTNL)	4	Touch the perfection

A a-2, b-4, c-1, d-3

B a-4, b-1, c-3, d-2

C a-4, b-3, c-1, d-2

D a-2, b-4, c-3, d-1

Answer: C

Explanation:

Toyota's tagline is 'Touch the perfection'.

BSNL's tagline is 'Connecting India'.

Airtel's tagline is 'Express yourself'.

MTNL's tagline is 'The easy way to stay in touch'.

Hence, option C is the correct answer.

Subscribe to MBA Exams Youtube Channel

Question 113

Match the name of the Indian Banks with their Brand Ambassadors for the year 2010.

	Name of the Banks		Name of the Brand Ambassador
a.	Canara Bank	1	Rahul Dravid
b.	Dena Bank	2	Hema Malini
c.	Bank of Rajasthan	3	Venkatesh Prasad
d.	Bank of Baroda	4	Juhi Chawla

- A a-4, b-3, c-1, d-2
- B a-3, b-1, c-4, d-2
- C a-2, b-3, c-1, d-4
- D a-3, b-4, c-2, d-1

Answer: D

Explanation:

The brand ambassador of Canara Bank is Venkatesh Prasad.
The brand ambassador of Dena Bank is Juhi Chawla.
The brand ambassador of Bank of Rajasthan is Hema Malini.
The brand ambassador of Bank of Baroda is Rahul Dravid.

Hence, option D is the correct answer.

Question 114

Match the following measuring instruments to the formal test methods which define the use of the Instrument

	Instruments		Use of instrument
a	Squid	i.	Heating of power radiation
b	Actionometer	ii.	Viscosity of a fluid
c	Dilatometer	iii.	Boiling temperature of a liquid
d	Ebulliscope	iv.	Coefficient of thermal expansion
e	Theometer	v.	Magnetic Field

- A a-v, b-i, c-iv, d-iii, e-ii
- B a-ii, b-i, c-v, d-iii, e-iv
- C a-v, b-iv, c-i, d-ii, e-iii
- D a-iii, b-iv, c-v, d-i, e-ii

Answer: A

Question 115

Name the Indian state having maximum number of Major Seaports.

- A West Bengal
- B Goa
- C Gujarat
- D Tamil Nadu

Answer: D

Explanation:

Tamil Nadu has the maximum number of major sea ports.
Hence, option D is the correct answer.

Free Mock Test for IIFT

Question 116

Match the National Highway route number to States that it covers?

	National Highway Route Number		Name of the Indian States which the NH covers
a.	National Highway Number 6	1	Punjab, Rajasthan, Gujarat
b.	National Highway Number 7	2	Delhi, Haryana, Rajasthan, Gujarat, Maharashtra
c.	National Highway Number 8	3	Orissa, Jharkhand, West Bengal, Gujarat
d.	National Highway Number 15	4	Uttar Pradesh, Madhya Pradesh, Maharashtra, Andhra Pradesh, Karnataka, Tamil Nadu

- A a-4, b-2, c-1, d-3
- B a-2, b-3, c-4, d-1
- C a-3, b-4, c-2, d-1
- D a-4, b-1, c-2, d-3

Answer: C

Explanation:

This question is based on the old numbering of National Highways in India.

NH6 runs through Gujarat, Maharashtra, Chhattisgarh, Odisha, Jharkhand and West Bengal state in India.

National Highway 7 or NH 7, is major North-South National Highway in India that runs through the states of Uttar Pradesh, Madhya Pradesh, Maharashtra, Telangana, Andhra Pradesh, Karnataka, and Tamil Nadu.

National Highway 8 is the busiest highway in the subcontinent, as it connects the national capital Delhi to the financial capital Mumbai, as well as important cities Gurgaon, Jaipur, Ajmer, Udaipur, Ahmedabad, Vadodara and Surat.

NH 15 runs through Pathankot - Amritsar - Tarn Taran Sahib - Bhatinda - Ganganagar - Bikaner - Jaisalmer - Barmer - Samakhiali (Punjab, Rajasthan and Gujarat)

Hence, option C is the correct answer.

Question 117

Match the old name to the new name of the countries.

	Old Name		New Name
a.	South West Africa	1	Ethiopia
b.	Rhodesia	2	Zambia
c.	Northern Rhodesia	3	Namibia
d.	Abyssinia	4	Zimbabwe

- A a-2, b-4, c-3, d-1

B a-3, b-4, c-2, d-1

C a-4, b-3, c-2, d-1

D a-1, b-4, c-2, d-3

Answer: B

Explanation:

Ethiopia was known as Abyssinia.

Zambia was known as Northern Rhodesia.

Namibia was known as South West Africa.

Zimbabwe was known as Rhodesia.

Hence, option B is the correct answer.

Question 118

Match the Country, City and River.

	Country		City		River
a.	Germany	i.	Lisbon	1	Vistula
b.	Poland	ii.	Chittagong	2	Karnafuli
c.	Portugal	iii.	Dreden	3	Tagus
d.	Bangladesh	iv.	Warsaw	4	Elbe

A a-i-3, b-iv-1, c-iii-2, d-ii-4

B a-iii-1, b-iv-3, c-i-4, d-ii-2

C a-iv-4, b-iii-1, c-i-2, d-ii-3

D a-iii-4, b-iv-1, c-i-3, d-ii-2

Answer: D

Explanation:

Warsaw is the capital of Poland.

Lisbon is the capital of portugal.

Chittagong is in Bangladesh.

Dresden is in Germany.

Hence, option D is the correct answer.

Download IIFT Previous Papers PDF

Question 119

Match the Geographical Epithet to Country/ City.

	Epithet		Country / City
a.	Quaker city	i.	Budapest
b.	Twin city	ii.	Chicago
c.	White city	iii.	Philadelphia
d.	Windy city	iv.	Belgrade

A a-1, b-4, c-3, d-2

B a-4, b-3, c-2, d-1

C a-3, b-1, c-4, d-2

D a-1, b-2, c-4, d-3

Answer: C

Explanation:

Budapest is known as Twin City.

Chicago is known as Windy City.

Philadelphia is known as Quaker City.

Belgrade is known as White City.

Hence, option C is the correct answer.

Question 120

The State Bank of India was known as Imperial Bank of India in 1921, which was an amalgamation of three banks namely.

A Bank of Bengal, Bank of Bombay and Bank of Madras

B Bank of Bengal, Bank of Punjab and Bank of Mysore

C Bank of Bombay, Syndicate Bank and Union Bank

D Bank of Madras, Mercantile Bank, Bank of Travancore

Answer: A

Explanation:

The State Bank of India was known as Imperial Bank of India in 1921, which was an amalgamation of Bank of Bengal, Bank of Bombay and Bank of Madras.

hence, option A is the correct answer.

Question 121

The Constitution of which country has influenced the inclusion of the "Emergency Provision" in the Indian Constitution.

A Germany

B Canada

C USA

D Britain

Answer: A

Explanation:

India has borrowed the concept of 'Emergency Provision' from Germany.

Hence, option A is the correct answer.

Download IIFT GK PDFs

Question 122

Which one of the following national park established by government of India is the relatively the latest one?

A Madhav National Park, Madhya Pradesh

B Khangchendzonga National Park, Sikkim

C Corbett National Park, Uttaranchal

D Tadoba National Park, Maharashtra

Answer: B

Explanation:

Madhav National Park, Madhya Pradesh was established in 1958.
Khangchendzonga National Park, Sikkim was established in 1977.
Corbett National Park, Uttaranchal was established in 1936.
Tadoba National Park, Maharashtra was established in 1955.

Hence, option B is the correct answer.

Question 123

Who among the following is a recipient of the prestigious Dara Shikoh award by Indo-Iran Society for contributing towards nurturing the value of peace, harmony and brotherhood in 2010.

- A Sheikh Hasina
- B Sonia Gandhi
- C Shiela Dixit
- D Fatima Bhutto

Answer: C

Explanation:

Shiela Dixit won prestigious Dara Shikoh award by Indo-Iran Society for contributing towards nurturing the value of peace, harmony and brotherhood in 2010.

Hence, option C is the correct answer.

Question 124

Which one of the following Indian Union Territory is having the legislative assembly as of 2010.

- A Dadra and Nagar Haveli
- B Lakshadeep
- C Puducherry
- D Andaman and Nicobar Islands

Answer: C

Explanation:

Puducherry is the Indian Union Territory is having the legislative assembly as of 2010.

Hence, option C is the correct answer.

IIFT Free Topic-Wise Important Questions (Study Material)

Question 125

Match the Lt Governors- Indian Union Territories- and the Capital.

	Lt. Governors		Union Territories		Capital
a.	J. K. Dadoo	i.	Dadra and Nagar Haveli	1	Kavaratti
b.	Satya Gopal	ii.	Puducherry	2	Port Blair
c.	Iqbal Singh	iii.	Andaman and Nicobar Island	3	Silvassa
d.	Lt. Gen. (Retd). Bhopinder Singh	iv.	Lakshadweep	4	Puducher y

- A a-iii-2, b-i-3, c-iv-1, d-ii-4
- B a-ii-4, b-iii-2, c-iv-3, d-i-1
- C a-i-3, b-iv-1, c-ii-4, d-iii-2
- D a-iv-1, b-i-3, c-ii-4, d-iii-2

Answer: D

Explanation:

The capital of Dadra and Nagar Haveli is Silvassa.
 The capital of Andaman & Nicobar Island is Port Blair.
 The capital of Puducherry is Puducherry.
 The capital of Lakshadweep is Karavatti.

Hence, option D is the correct answer.

Question 126

Which one of the following structure has been included in UNESCO in 2010 as world cultural heritage list?

- A Chhatrapati Shivaji Terminus
- B Jantar Mantar
- C Mahabodhi Temple Complex at Bodh Gaya
- D Red Fort Complex

Answer: B

Explanation:

Jantar Mantar was included in UNESCO's world's cultural heritage list in 2010.
 Hence, option B is the correct answer.

Question 127

Match the following Head of the Staff to the concerned Defense forces.

	Head of the Staff		Defence Force
a.	Pradeep Vasant Naik	i.	Chief of Integrated Defense Staff
b.	Vijay Kumar Singh	ii.	Chief of Naval Staff
c.	Nirmal Verma	iii.	Chief of Army Staff
d.	Suresh Chand Mukul	iv.	Chief of Air Staff

- A a-3, b-4, c-1, d-2
- B a-4, b-3, c-2, d-1
- C a-3, b-2, c-1, d-4
- D a-1, b-2, c-4, d-3

Answer: B

Explanation:

Pradeep Vasant Naik is the Chief of Air Staff.

Vijay Kumar Singh is the Chief of Army Staff.
 Nirmal Verma is the Chief of Naval Staff.
 Suresh Chand Mukul is the Chief of Integrated Defense Staff.

Hence, option B is the correct answer.

Top 500+ Free Questions for IIFT

Question 128

Which one of the following state is having maximum number of special economic zone (SEZ), notified under the SEZ Act, 2005.

- A Andhra Pradesh
- B Maharashtra
- C Tamil Nadu
- D Karnalaka

Answer: D

Question 129

Match the following Brand to the Company.

	Brand		Company
a.	Santoor	i.	Hindustan Unilever Limited
b.	Margo	ii.	Wipro
c.	Camay	iii.	Henkel
d.	Hamam	iv.	Proctor and Gamble

- A a-4, b-1, c-2, d-3
- B a-2, b-3, c-4, d-1
- C a-3, b-1, c-4, d-2
- D a-2, b-4, c-1, d-3

Answer: B

Explanation:

Santoor is the brand of Wipro.
 Margo is the brand of Henkel.
 Camay is the brand of Proctor & Gamble.
 Hamam is the brand of HUL.

Hence, option B is the correct answer.

Question 130

Match the Countries - Name of the parliament - Currency

	Country		Name of the Parliament		Currency
a.	Sweden	i.	Diet	1	Yen
b.	Japan	ii.	Riksdag	2	Zloty
c.	Poland	iii.	Knessat	3	Krona
d.	Israel	iv.	Sejm	4	New Shekkel

- A a-iii-2, b-iv-1, c-i-4, d-ii-3
- B a-ii-3, b-i-1, c-iv-2, d-iii-4
- C a-iv-2, b-iii-1, c-ii-4, d-i-3
- D a-ii-3, b-i-1, c-iii-4, d-iv-2

Answer: B

Explanation:

The currency of Sweden is Krona.
 The currency of Japan is Yen.
 The currency Poland is Zloty.
 The currency of Israel is New Shekkel.
 Hence, option B is the correct answer.

Download IIFT Syllabus PDF

Question 131

Name the sports personality who is not an ambassador for the Common WealthGames 2010.

- A Samaranth Jung
- B Sushil Kumar
- C MC Mary Kom
- D Tejaswini Sawant

Answer: D

Explanation:

Tejaswini Sawant was not an ambassador of Commonwealth Games, 2010.
 Hence, option D is the correct answer.

Question 132

Match the Central Public Sector Enterprises in India and their position

	CPSE		Position
a.	Steel Authority of India Limited	i.	Mini Ratna Category – I
b.	Gas Authority of India Limited	ii.	Maharatna
c.	Bharat Sanchar Nigam Limited	iii.	Mini Ratna Category – II
d.	Hindustan Machines and Tools	iv.	Navratna

- A a-3, b-2, c-4, d-1
- B a-2, b-4, c-1, d-3
- C a-2, b-4, c-3, d-1
- D a-4, b-2, c-1, d-3

Answer: B

Explanation:

SAIL is a Maharatna company.

GAIL is a Navratna company.

BSNL is a Mini Ratna category-I company.

HMT is a Mini Ratna Category-II company.

Hence, option B is the correct answer.

Question 133

Select the country that has maximum share in FDI equity inflow in India as on June 2010.

A Germany

B UAE

C France

D Netherland

Answer: D

Explanation:

Netherlands has the maximum share in FDI equity inflow as in June 2010.

Hence, option D is the correct answer.

Quant Formulas for IIFT PDF

Question 134

Which sector attracted minimum FDI equity Inflow in India in the year 2009 2010?

A Construction activities

B Housing and real estate

C Telecommunications

D Power

Answer: D

Question 135

Match the Indian TV Channel to its Owners/ Parent Company

	TV Channel		Owner / Parent Company
a.	CNBC	i.	Bennett, Coleman and Co. Ltd
b.	Times Now	ii.	Raghav Bahal
c.	Star News	iii.	India Today Group
d.	Aaj Tak	iv.	Anand Bazar Publication

A a-2, b-4, c-3, d-1

B a-2, b-1, c-4, d-3

C a-2, b-3, c-4, d-1

D a-3, b-1, c-4, d-2

Answer: B

Explanation:

CNBC is owned by Raghav Bahal.

Times Now is owned by Bennett, Coleman and Co. Ltd.

Star News is owned by Anand Bazar Publication.

Aaj Tak is owned by India Today group.

Hence, option B is the correct answer.

IIFT Free Preparation App

Free Mock Test for IIFT

Download IIFT Previous Papers PDF

Download IIFT GK PDFs

IIFT Free Topic-Wise Important Questions (Study Material)

Top 500+ Free Questions for IIFT

Download IIFT Syllabus PDF

Quant Formulas for IIFT PDF

IIFT Free Preparation App

Download General Science Notes for IIFT PDF

Take 3 Free CAT Mocks (With Solutions)

XAT Previous Papers

CMAT Free Solved Previous Papers.

MAT Free Solved Previous Papers

**PGDBA Previous Year Papers (Download PDF) PGDBA Previous Year Papers
(Download PDF)**

CAT Previous Papers PDF

[Take a XAT Free Mock Test](#)

[Take a CMAT free mock test](#)

[Take a free SNAP mock test](#)

[Take a NMAT free mock test](#)

[Join MBA Telegram Group](#)

[Subscribe to MBA Exams Youtube Channel](#)