

Andhra Pradesh State Council of Higher Education

Notations :

- 1.Options shown in green color and with ✓ icon are correct.
- 2.Options shown in red color and with ✗ icon are incorrect.

Question Paper Name :	Electronics and Communication Engineering 28th Sep 2021 Shift1
Duration :	120
Total Marks :	120
Display Marks:	No
Share Answer Key With Delivery Engine :	Yes
Calculator :	None
Magnifying Glass Required? :	No
Ruler Required? :	No
Eraser Required? :	No
Scratch Pad Required? :	No
Rough Sketch/Notepad Required? :	No
Protractor Required? :	No
Show Watermark on Console? :	Yes
Highlighter :	No
Auto Save on Console? (SA type of questions will be always auto saved) :	Yes
Is this Group for Examiner? :	No

Electronics and Communication Engineering

Section Id :	5875874
Section Number :	1
Mandatory or Optional :	Mandatory
Number of Questions :	120
Section Marks :	120
Enable Mark as Answered Mark for Review and Clear Response :	Yes

Question Number : 1 Question Id : 587587361 Display Question Number : Yes Is Question

Mandatory : No

Let L denote the inductance in henry (H) and C denote the capacitance in farad (F). The reciprocal of the geometric mean of L and C has unit -----.

Options :

- ✘ hertz
- ✘ radian
- ✘ second
- ✔ radian per second

Question Number : 2 Question Id : 587587362 Display Question Number : Yes Is Question

Mandatory : No

Suppose that the time-varying current through a capacitor of $9 \mu\text{F}$ is $9\delta(t)$ microampere. The time-varying voltage across the capacitor is -----.

Options :

- ✘ $9u(t)$
- ✔ $u(t)$

3. ✘ $81 u(t)$

4. ✘ $(1/9) u(t)$

Question Number : 3 Question Id : 587587363 Display Question Number : Yes Is Question

Mandatory : No

Suppose that three identical 9 A, 1 Ω Norton equivalent circuits are connected in parallel with like polarity. Then, the net current and conductance in the combined Norton equivalent circuit will be -----.

Options :

1. ✘ 27 A, 1 mho

2. ✔ 27 A, 3 mho

3. ✘ 9 A, 1 mho

4. ✘ 9 A, 3 mho

Question Number : 4 Question Id : 587587364 Display Question Number : Yes Is Question

Mandatory : No

Suppose that a dc source with source resistance R_s could provide a current of 4 A when it is short circuited momentarily. Further, it can provide a power of 81 watts to a 9 Ω load. The maximum power delivered to the load is -----.

Options :

1. ✔ 108 watts

2. ✘ 81 watts

3. ✘ 27 watts

4. ✘ 216 watts

Question Number : 5 Question Id : 587587365 Display Question Number : Yes Is Question

Mandatory : No

Consider a series RLC circuit with Q factor 108. Suppose that all the R, L and C components values are quadrupled, the Q factor of the resultant circuit will be -----.

Options :

1. ✘ 108

2. ✘ 432

3. ✔ 27

4. ✘ 54

Question Number : 6 Question Id : 587587366 Display Question Number : Yes Is Question

Mandatory : No

Refer to the circuit diagram shown below. In it, $R_1 = R_2 = 10^6 \Omega$ and $I = 9 \mu\text{A}$. The resistance R is equal to -----.

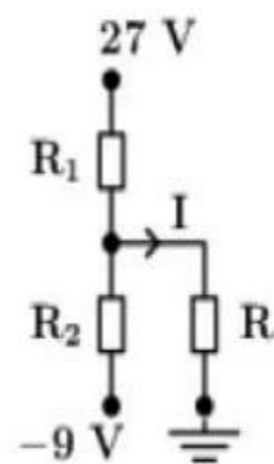

Options :

1. ✘ 100 $\text{K}\Omega$

2. ✘ 200 $\text{K}\Omega$

3. ✘ 400 KΩ

4. ✔ 500 KΩ

Question Number : 7 Question Id : 587587367 Display Question Number : Yes Is Question

Mandatory : No

Suppose that the Z-parameter matrices of two two-port network are $\begin{bmatrix} 4 & 2 \\ 2 & 4 \end{bmatrix}$ and $\begin{bmatrix} 2 & 1 \\ 1 & 2 \end{bmatrix}$. If the two-port networks are connected in series, the admittance parameters matrix of the overall two-port network is ----.

Options :

1. ✘ $\begin{bmatrix} 2/9 & 1/9 \\ -1/9 & 2/9 \end{bmatrix}$

2. ✔ $\begin{bmatrix} 2/9 & -1/9 \\ -1/9 & 2/9 \end{bmatrix}$

3. ✘ $\begin{bmatrix} 1/9 & 2/9 \\ 2/9 & 1/9 \end{bmatrix}$

4. ✘ $\begin{bmatrix} 1/9 & -2/9 \\ -2/9 & 1/9 \end{bmatrix}$

Question Number : 8 Question Id : 587587368 Display Question Number : Yes Is Question

Mandatory : No

Consider a circuit of sixteen branches and four nodes. Suppose that you use loop analysis to find currents. The number of independent loops is -----.

Options :

1. ✘ 12

2. ✘ 20

3. ✔ 13

4. ✘ 11

Question Number : 9 Question Id : 587587369 Display Question Number : Yes Is Question

Mandatory : No

Suppose that a capacitor stores one microjoule of electrical potential energy. The amount of charge stored in it is $1 \mu\text{C}$. The capacitance is given by -----.

Options :

1. ✘ $1 \mu\text{F}$

2. ✘ $2 \mu\text{F}$

3. ✔ $0.5 \mu\text{F}$

4. ✘ $10 \mu\text{F}$

Question Number : 10 Question Id : 587587370 Display Question Number : Yes Is Question

Mandatory : No

Suppose that the average power in a pure resistance that carries a time-varying current $i(t) = \cos(\omega t)$ A, is 9 watt. The resistor is of -----.

Options :

1. ✘ 9Ω

2. ✔ 18Ω

3. ✘ 3Ω

4. ✘ 81Ω

Question Number : 11 Question Id : 587587371 Display Question Number : Yes Is Question

Mandatory : No

Consider a 9 V battery having negligible internal resistance is connected to a coil of inductance 4 H and resistance 1 Ω . The amount of energy stored in the magnetic field is -----.

Options :

1. ✘ 81 joules

2. ✘ 9 joules

3. ✘ 36 joules

4. ✔ 162 joule

Question Number : 12 Question Id : 587587372 Display Question Number : Yes Is Question

Mandatory : No

The time-varying currents $i_1(t)$, $i_2(t)$, and $i_3(t)$ (in mA), are meeting at a junction as shown in the Fig. below. Suppose that $i_1(t) = 8 \cos(\omega t)$, $i_2(t) = -9 \sin(\omega t)$. The current $i_3(t)$ is given by -----.

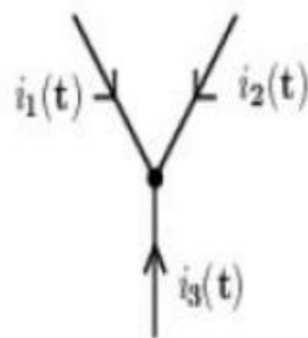

Options :

1. ✔ $-8-j9$ mA

2. ✘ $8-j9$ mA

3. ✘ $8+j9$ mA

4. ✘ $-1+j0$ mA

Question Number : 13 Question Id : 587587373 Display Question Number : Yes Is Question

Mandatory : No

Suppose that a series resonant circuit has a resistance of 33Ω , inductance of 1 H, and capacitance of $1 \mu\text{F}$. Let the supply voltage is 29.7 V. The current flowing through the circuit at resonance is -----.

Options :

1. ✘ 0.3 A

2. ✘ 0.6 A

3. ✔ 0.9 A

4. ✘ 3 A

Question Number : 14 Question Id : 587587374 Display Question Number : Yes Is Question

Mandatory : No

Refer to the circuit shown below. Suppose that the switch closes at $t = 0$. The value of current at $t = 2$ second is approximately-----.

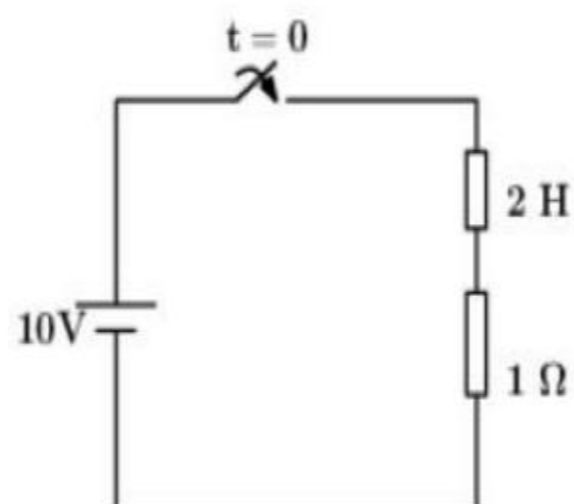

Options :

1. ✘ 0.63 A

2. ✓ 6.3 A

3. ✗ 3.6 A

4. ✗ 10 A

Question Number : 15 Question Id : 587587375 Display Question Number : Yes Is Question Mandatory : No

Refer to the two-port network shown below. In it, the value of Z_{in} is equal to -----.

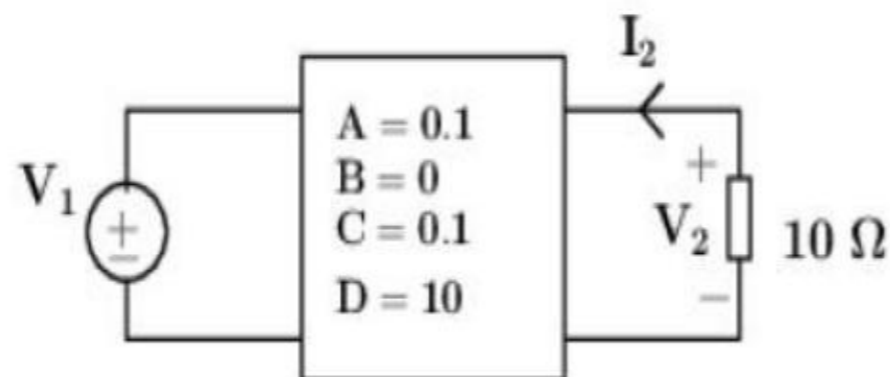

Options :

1. ✓ $(1/11) \Omega$

2. ✗ $(2/11) \Omega$

3. ✗ $(3/11) \Omega$

4. ✗ $(4/11) \Omega$

Question Number : 16 Question Id : 587587376 Display Question Number : Yes Is Question Mandatory : No

Suppose that the length of an intrinsic silicon bar is 5 cm and its cross-section is 2 mm by 4 mm. Assuming room temperature and resistivity equal to $2.4 \times 10^5 \Omega - cm$, the resistance of the bar is equal to -----.

Options :

1. ✘ 1.5 MΩ

2. ✔ 15 MΩ

3. ✘ 150 MΩ

4. ✘ 0.15 MΩ

Question Number : 17 Question Id : 587587377 Display Question Number : Yes Is Question

Mandatory : No

Suppose that an electric field intensity of 1 volt/cm is applied across a semiconductor at a certain temperature. If the average drift velocity of free electrons is equal to 10 m/s, the electron mobility is equal to -----.

Options :

1. ✘ 10 cm²/V-sec.

2. ✘ 100 cm²/V-sec.

3. ✘ 0.1 cm²/V-sec.

4. ✔ 1000 cm²/V-sec.

Question Number : 18 Question Id : 587587378 Display Question Number : Yes Is Question

Mandatory : No

The key purpose of the metallization process is to -----.

Options :

1. ✘ serve as a ground plane

2. ✘ protect the chip from oxidation

3. ✓ interconnect various circuit elements
4. ✗ supply a bonding interface for mounting the chip

Question Number : 19 Question Id : 587587379 Display Question Number : Yes Is Question

Mandatory : No

Compared to discrete component systems, monolithic integrated systems offer superior reliability. This is due to -----.

Options :

1. ✗ use of silicon
2. ✓ fewer interconnections
3. ✗ hermetically sealed
4. ✗ reduction in size is achieved

Question Number : 20 Question Id : 587587380 Display Question Number : Yes Is Question

Mandatory : No

Unlike BJT, the thermal runaway is not a problem in FET. The thermal stability in FET is because as temperature increases, -----.

Options :

1. ✗ transconductance increases
2. ✓ mobility decreases
3. ✗ mobility increases

4. ✘ the drain current increases

Question Number : 21 Question Id : 587587381 Display Question Number : Yes Is Question

Mandatory : No

Which of the following is the basic material commonly used for the fabrication for an LED?

Options :

1. ✘ SiC

2. ✘ Ge

3. ✔ GaAs

4. ✘ SiO₂

Question Number : 22 Question Id : 587587382 Display Question Number : Yes Is Question

Mandatory : No

Suppose that a Si sample is doped with arsenic (As) atoms having concentration 10^{18} As atoms/cm³. The equilibrium hole concentration at room temperature is -----.
(Note: Intrinsic concentration for Si at room temperature = 1.5×10^{10} cm⁻³.)

Options :

1. ✘ 1.5×10^2 cm⁻³

2. ✘ 0.15×10^2 cm⁻³

3. ✔ 2.25×10^2 cm⁻³

4. ✘ 22.5×10^2 cm⁻³

Question Number : 23 Question Id : 587587383 Display Question Number : Yes Is Question

Mandatory : No

The duration it takes for an average electron to drift $2.7\mu\text{m}$ in pure Si at an electric field of 100 V/cm is -----, (Given: $\mu_n = 1350\text{ cm}^2/\text{V-sec}$.)

Options :

1. ✘ 1 ns

2. ✔ 2 ns

3. ✘ 3 ns

4. ✘ 4 ns

Question Number : 24 Question Id : 587587384 Display Question Number : Yes Is Question

Mandatory : No

Energy E (in eV), wavelength λ (in nm) of a photon are related through the expression given by -----,

Options :

1. ✔ $\lambda = \frac{0.00124}{E}$

2. ✘ $\lambda = \frac{1.24}{E}$

3. ✘ $\lambda = \frac{0.0124}{E}$

4. ✘ $\lambda = \frac{12.4}{E}$

Question Number : 25 Question Id : 587587385 Display Question Number : Yes Is Question

Mandatory : No

Suppose that increasing the MOSFET device temperature, the subthreshold source-to-drain leakage current of the MOSFET -----.

Options :

1. ✘ decreases
2. ✘ unchanged
3. ✔ increases
4. ✘ Increases initially, then decreases after some threshold

Question Number : 26 Question Id : 587587386 Display Question Number : Yes Is Question

Mandatory : No

Refer to the following energy band diagram. In it, E_F denotes Fermi level energy. The energy band diagram characterizes a -----.

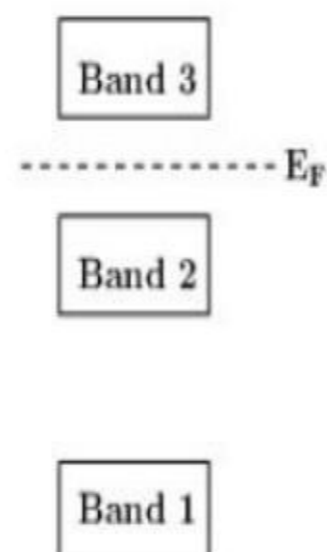

Options :

1. ✘ Insulator
2. ✘ Metal
3. ✘ Non-metal conductor
4. ✔ Semiconductor

Question Number : 27 Question Id : 587587387 Display Question Number : Yes Is Question

Mandatory : No

A 90 mW, 900 nm LASER beam is focused onto a GaAs sample of thickness 100 μ m. The energy of one photon is approximately equal to -----.

Options :

1. ✘ 1.24 eV
2. ✔ 1.38 eV
3. ✘ 0.62 eV
4. ✘ 0.69 eV

Question Number : 28 Question Id : 587587388 Display Question Number : Yes Is Question

Mandatory : No

Suppose that an abrupt Si p-n junction of area 10^{-8} m^{-2} and has n-side $\mu_p = 500 \text{ cm}^2/\text{V-sec}$. at room temperature. For the minority carrier the diffusion constant (for holes) is approximately -----.

Options :

1. ✘ 1.3 cm^2/sec
2. ✘ 130 cm^2/sec
3. ✔ 13 cm^2/sec
4. ✘ 26 cm^2/sec

Question Number : 29 Question Id : 587587389 Display Question Number : Yes Is Question

Mandatory : No

Consider the MOSFET characteristic curves shown in Fig. The transconductance g_m (in mho) at $V_D = -1.0$ V is -----.

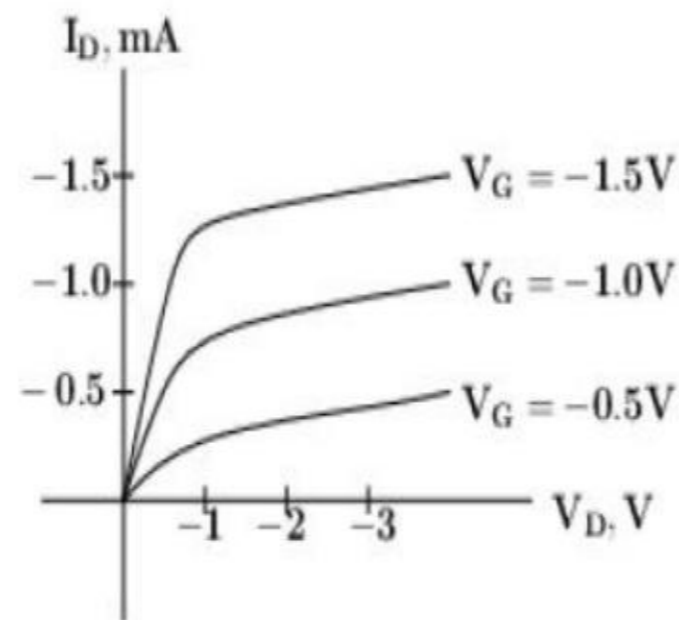

Options :

1. ✘ 0.5 millimho
2. ✔ 1 millimho
3. ✘ 1.5 millimho
4. ✘ 0.25 millimho

Question Number : 30 Question Id : 587587390 Display Question Number : Yes Is Question

Mandatory : No

Suppose that in the BJT characteristic curves $\Delta I_C = 5$ mA and $\Delta I_B = 0.1$ mA. The common emitter gain β is approximately equal to -----.

Options :

1. ✘ 100
2. ✔ 50
3. ✘ 150
4. ✘ 200

Question Number : 31 Question Id : 587587391 Display Question Number : Yes Is Question

Mandatory : No

Consider an open-circuited p-n junction diode at room temperature. Suppose that the donor ions concentration N_D is changed by a factor of 10000 and acceptor ions concentration N_A remains unchanged. The contact difference of potential V_0 is approximately equal to -----
--. (Use: $\ln 9 \approx 2.3$, $V_T = 0.026 V$.)

Options :

1. ✓ 0.24 V

2. ✗ 2.4 V

3. ✗ 24 mV

4. ✗ 1.2 V

Question Number : 32 Question Id : 587587392 Display Question Number : Yes Is Question

Mandatory : No

Consider a Si diode ($\eta = 2$) operating in the conducting region at room temperature. The approximate change in voltage for a tenfold increase in current is -----.

(Use: $I \approx I_0 e^{V/\eta V_T}$, $\ln 10 \approx 2.3$, $V_T = 0.026 V$.)

Options :

1. ✗ 0.24 V

2. ✗ 0.06 V

3. ✓ 0.12 V

4. ✗ 0.48 V

Question Number : 33 Question Id : 587587393 Display Question Number : Yes Is Question

Mandatory : No

Suppose that two p-n Si diodes ($\eta = 2$) are connected in series opposing. In it, the reverse saturation current is 10 nA. A 6 V battery is connected to this series arrangement. If the Zener (Avalanche) voltage is 10 V, the voltage across the reverse bias diode is -----.

(Use: $\ln 2 \approx 0.693, V_T = 0.026 V$.)

Options :

1. ✘ 0.036 V

2. ✔ 5.964 V

3. ✘ 6 V

4. ✘ 6.036 V

Question Number : 34 Question Id : 587587394 Display Question Number : Yes Is Question

Mandatory : No

Suppose that a Si p-n diode is in series with a 2 K Ω resistor and 10 V power supply. If the diode is forward biased, the approximate current in the circuit is -----.

(Assume $V_f = 0.6 V$.)

Options :

1. ✘ 0.35 mA

2. ✘ 5.65 mA

3. ✘ 0 mA

4. ✔ 4.65 mA

Question Number : 35 Question Id : 587587395 Display Question Number : Yes Is Question

Mandatory : No

A Si transistor with $h_{FE} = 100$ is used in the circuit shown. In it, $V_{CC} = 10\text{ V}$, $R_C = 4.9\text{ K}\Omega$, $V_{in} = 5\text{ V}$.

The maximum value of R_b for which the transistor remains in saturation is (Assume $V_{BE,sat} = 0.6\text{ V}$.)

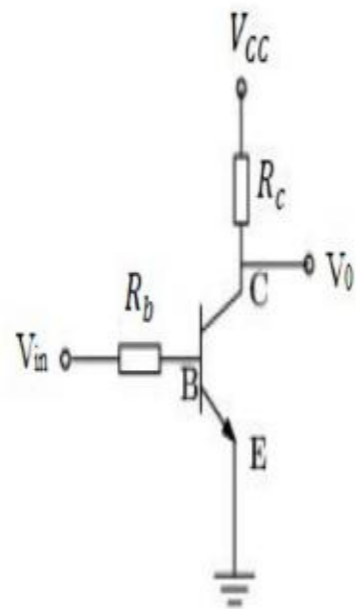

Options :

- 1. ✓ 210 K Ω
- 2. ✗ 21 K Ω
- 3. ✗ 2.1 K Ω
- 4. ✗ 2.1 M Ω

Question Number : 36 Question Id : 587587396 Display Question Number : Yes Is Question

Mandatory : No

Suppose that A BJT has $\alpha = 0.99$, $I_B = 10\ \mu\text{A}$, $I_{CBO} = 100\ \text{nA}$. The dc collector current is

Options :

- 1. ✗ 10.1 mA
- 2. ✓ 1.10 mA
- 3. ✗ 0.01 mA
- 4. ✗ 101 μA

Question Number : 37 Question Id : 587587397 Display Question Number : Yes Is Question

Mandatory : No

Consider a p-n diode whose internal resistance is $10\ \Omega$. This diode is to supply power to a $900\ \Omega$ load from a $\frac{100}{\sqrt{2}}$ (rms) power supply. The dc load current is approximately -----.

Options :

1. ✘ 320 mA
2. ✔ 32 mA
3. ✘ 16 mA
4. ✘ $0.32\ \mu\text{A}$

Question Number : 38 Question Id : 587587398 Display Question Number : Yes Is Question

Mandatory : No

Refer to the Op-Amp circuit diagram shown. The voltage gain is equal to -----.

(Given: open-loop gain = 99.)

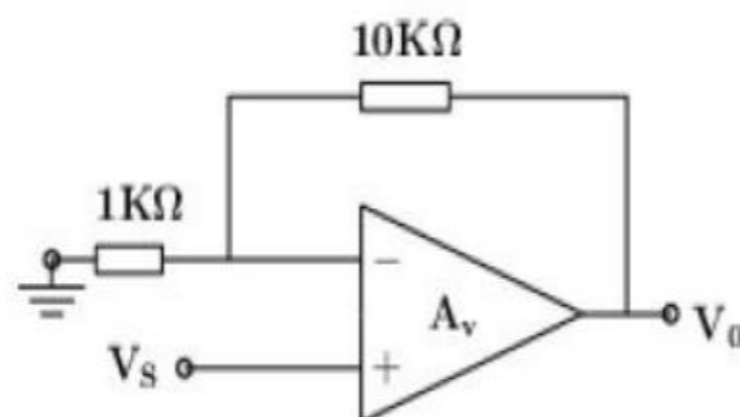

Options :

1. ✘ 99.9
2. ✘ 9
3. ✔ 9.9

4. ✘ 11

Question Number : 39 Question Id : 587587399 Display Question Number : Yes Is Question

Mandatory : No

For the circuit shown in Fig., let $v_1 = 10\text{ V}$, $v_2 = 0\text{ V}$. Suppose that the p-n diode cut-in voltage is 0.6 V and the voltage drop across the conducting diode is 0.7 V . Assuming an infinite resistance for a diode which is reverse biased, the output v_0 is approximately-----.

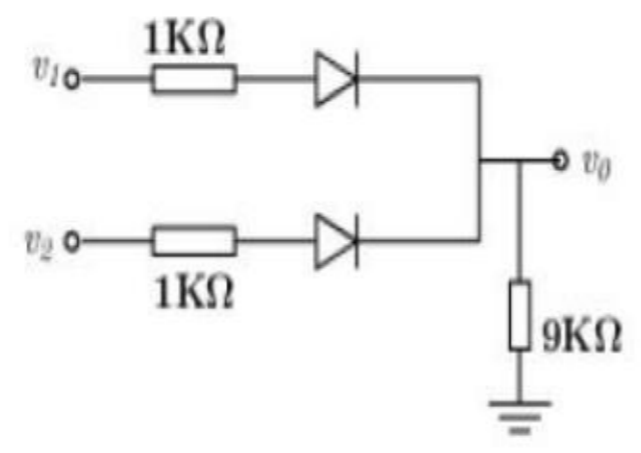

Options :

- 1. ✔ 8.4 V
- 2. ✘ 0.84 V
- 3. ✘ 9.6 V
- 4. ✘ 0.6 V

Question Number : 40 Question Id : 587587400 Display Question Number : Yes Is Question

Mandatory : No

Consider a power supply that has no load voltage of 21.4 V . The approximate full load voltage for 7% regulation is approximately -----.

Options :

- 1. ✘ 10 V
- 2. ✔ 20 V

3. ✘ 30 V

4. ✘ 15 V

Question Number : 41 Question Id : 587587401 Display Question Number : Yes Is Question Mandatory : No

Consider a BJT operating in saturation region. Suppose that $V_{CC} = 9\text{ V}$, $R_C = x\text{ K}\Omega$, $h_{FE} = 100$, $V_{CE,sat} = 0.3\text{ V}$. The collector current at saturation is 17.4 mA. The resistance R_C is -----

Options :

1. ✘ 1 K Ω

2. ✘ 2 K Ω

3. ✔ 0.5 K Ω

4. ✘ 3 K Ω

Question Number : 42 Question Id : 587587402 Display Question Number : Yes Is Question Mandatory : No

Suppose that a power amplifier has a power gain (in linear scale) of 128. The power gain in dB is approximately equal to -----.

Options :

1. ✘ 42 dB

2. ✔ 21 dB

3. ✘ 7 dB

4. ✘ 14 dB

Question Number : 43 Question Id : 587587403 Display Question Number : Yes Is Question

Mandatory : No

Consider FET Hartley oscillator with $C = 250 \text{ pF}$, $L_{eq} = 4 \text{ mH}$. The oscillation frequency is ----- . (Use: $\frac{1}{2\pi} \approx 0.16$.)

Options :

1. ✘ 16 KHz

2. ✘ 1.6 KHz

3. ✔ 160 KHz

4. ✘ 1.6 MHz

Question Number : 44 Question Id : 587587404 Display Question Number : Yes Is Question

Mandatory : No

For a JFET, g_{m0} denotes the transconductance at $V_{GS} = 0 \text{ V}$. Suppose that a JFET has $I_{DSS} = 12 \text{ mA}$, $V_p = -4 \text{ V}$. The g_{m0} is equal to ----- .

Options :

1. ✘ 3 millisiemen

2. ✘ 4 millisiemen

3. ✘ 1 millisiemen

4. ✔ 6 millisiemen

Question Number : 45 Question Id : 587587405 Display Question Number : Yes Is Question

Mandatory : No

Suppose that $I_{DSS} = 9 \text{ mA}$, $V_p = -4 \text{ V}$, $V_{GS} = -2 \text{ V}$. The drain current I_D is equal to -----.

Options :

1. ✘ 1.5 mA

2. ✘ 3 mA

3. ✔ 2.25 mA

4. ✘ 2 mA

Question Number : 46 Question Id : 587587406 Display Question Number : Yes Is Question

Mandatory : No

Consider 8085 microprocessor instruction set. The XRA instruction word size is equal to -----

Options :

1. ✘ 3 bytes

2. ✘ 2 bytes

3. ✘ 4 bytes

4. ✔ 1 byte

Question Number : 47 Question Id : 587587407 Display Question Number : Yes Is Question

Mandatory : No

Consider the following 8085 instruction set. The number of times the loop will be executed is

LXI B, 0009H

LOOP: DCX B

JNZ LOOP

Options :

1. ✘ 8

2. ✘ 9

3. ✘ 10

4. ✔ Infinite loop

Question Number : 48 Question Id : 587587408 Display Question Number : Yes Is Question

Mandatory : No

The number of address lines necessary to address two megabytes (i.e. 2048K) of memory is

Options :

1. ✘ 11

2. ✘ 10

3. ✔ 21

4. ✘ 12

Question Number : 49 Question Id : 587587409 Display Question Number : Yes Is Question

Mandatory : No

In 8085 microprocessors, if the clock frequency is 3 MHz, the time duration required to execute an instruction of 18 T-states is approximately -----.

Options :

1. ✘ $0.6\mu\text{s}$
2. ✔ $6\mu\text{s}$
3. ✘ $60\mu\text{s}$
4. ✘ $600\mu\text{s}$

Question Number : 50 Question Id : 587587410 Display Question Number : Yes Is Question Mandatory : No

Refer to the digital logic circuit diagram shown. It performs ----- gate operation.

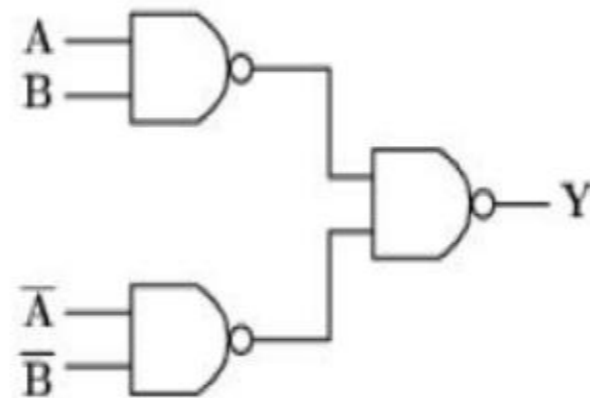

Options :

1. ✘ XNOR
2. ✔ XOR
3. ✘ NAND
4. ✘ NOR

Question Number : 51 Question Id : 587587411 Display Question Number : Yes Is Question Mandatory : No

The binary equivalent of 22.5 (decimal number system) is -----.

Options :

1. ✓ 10110.10

2. ✗ 10110.11

3. ✗ 10110.01

4. ✗ 10110.001

Question Number : 52 Question Id : 587587412 Display Question Number : Yes Is Question

Mandatory : No

Consider a ripple counter that operates at a maximum frequency of 10 MHz. Suppose that the propagation delay time of each flip-flop in the counter is 10 ns, and strobing time is 50 ns, the number of stages in the counter is -----.

Options :

1. ✗ 2

2. ✗ 3

3. ✓ 5

4. ✗ 7

Question Number : 53 Question Id : 587587413 Display Question Number : Yes Is Question

Mandatory : No

Consider a 256×8 – bit ROM using two-dimensional addressing with 8-to-1 selectors. The number of bits needed to address the ROM is -----.

Options :

1. ✗ 11

2. ✘ 9

3. ✘ 6

4. ✔ 8

Question Number : 54 Question Id : 587587414 Display Question Number : Yes Is Question

Mandatory : No

Suppose that we need to design a 25:1 asynchronous counter. The number of flip-flops required is -----

Options :

1. ✘ 4

2. ✔ 5

3. ✘ 6

4. ✘ 8

Question Number : 55 Question Id : 587587415 Display Question Number : Yes Is Question

Mandatory : No

Suppose that we need to design a multiplexer to generate the following combinational logic equation:

$$Y = \bar{D}\bar{C}\bar{B}\bar{A} + \bar{D}C\bar{B}\bar{A} + D\bar{C}\bar{B}\bar{A} + D\bar{C}B\bar{A} + \bar{D}\bar{C}B\bar{A} + DC\bar{B}\bar{A} + \bar{D}C\bar{B}A + DCBA$$

The number of data inputs required is -----.

Options :

1. ✘ 4

2. ✘ 16

3. ✓ 8

4. ✗ 32

Question Number : 56 Question Id : 587587416 Display Question Number : Yes Is Question Mandatory : No

Consider the following standard product of sums.

$$f(A, B, C) = (A + \bar{B} + C)(A + B + C)(A + \bar{B} + \bar{C}).$$

This can be simplified to -----.

Options :

1. ✗ $\bar{A} + B C$

2. ✓ $A + \bar{B} C$

3. ✗ $A + \bar{B} \bar{C}$

4. ✗ $\bar{A} + \bar{B} \bar{C}$

Question Number : 57 Question Id : 587587417 Display Question Number : Yes Is Question Mandatory : No

An 8-bit ADC is used to digitize an analog signal in the 0 to 5 V range. The maximum peak to peak ripple voltage that can be allowed in the dc supply voltage is approximately -----.

Options :

1. ✓ 20 mV

2. ✗ 10 mV

3. ✗ 5 mV

4. ✘ 40 mV

Question Number : 58 Question Id : 587587418 Display Question Number : Yes Is Question

Mandatory : No

An 8-bit DAC provides an analog output which has a peak value of 5.12 volt. The resolution of the DAC is -----.

Options :

1. ✘ 40 mV

2. ✘ 30 mV

3. ✘ 15 mV

4. ✔ 20 mV

Question Number : 59 Question Id : 587587419 Display Question Number : Yes Is Question

Mandatory : No

The figure of merit of digital IC logic family is the product of -----.

Options :

1. ✘ noise margin and power dissipation

2. ✘ bandwidth and gain

3. ✔ propagation delay and power dissipation

4. ✘ propagation delay and fan-in

Question Number : 60 Question Id : 587587420 Display Question Number : Yes Is Question

Mandatory : No

For the digital logic circuit shown, the expression for Y is given by -----.

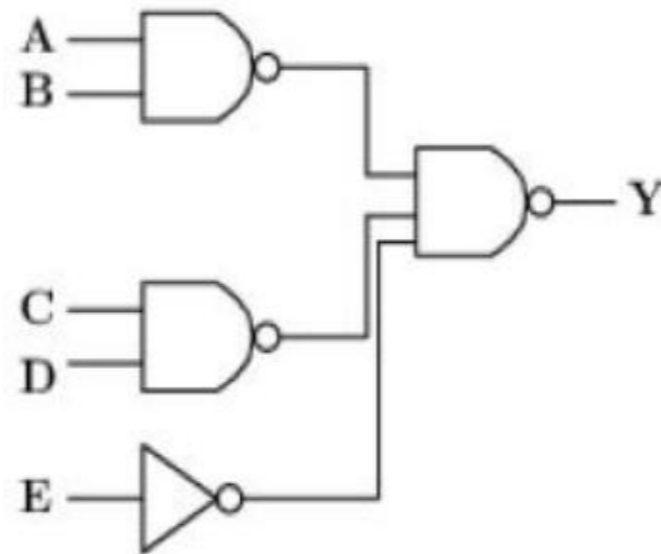

Options :

1. ✓ $AB + CD + E$

2. ✗ $AB + CD \bar{E}$

3. ✗ $\bar{A}\bar{B} + CD + \bar{E}$

4. ✗ $AB + \bar{C}\bar{D} + E$

Question Number : 61 Question Id : 587587421 Display Question Number : Yes Is Question

Mandatory : No

Let $g(t) = \sum_{k=-\infty}^{\infty} \delta(t - kT)$, a periodic delta function with period T. The Fourier transform of g(t) denoted by G(f) is -----.

Options :

1. ✗ $(1/T) \sum_{k=-\infty}^{\infty} \delta(f - kT)$

2. ✓ $(1/T) \sum_{k=-\infty}^{\infty} \delta(f - (k/T))$

3. ✗ $\sum_{k=-\infty}^{\infty} \delta(f - (k/T))$

4. ✘ $\sum_{k=-\infty}^{\infty} \delta(f - KT)$

Question Number : 62 Question Id : 587587422 Display Question Number : Yes Is Question

Mandatory : No

The transfer function of a system is given by $H(f) = -2j \operatorname{sgn}(f)$ where 'sgn' denotes the signum function. Its impulse response is given by -----.

Options :

1. ✘ $\frac{2}{t}$

2. ✔ $\frac{2}{\pi t}$

3. ✘ $2t$

4. ✘ πt

Question Number : 63 Question Id : 587587423 Display Question Number : Yes Is Question

Mandatory : No

The transfer function of a low pass filter in the interval $f \in (-0.5, 0.5)$ is given by

$$H(f) = \exp(-j \pi f).$$

What is the impulse response?

Options :

1. ✔ $\operatorname{sinc}(t-0.5)$

2. ✘ $\operatorname{sinc}(t+0.5)$

3. ✘ $\operatorname{sinc}(t-1)$

4. ✘ $\text{sinc}(t+1)$

Question Number : 64 Question Id : 587587424 Display Question Number : Yes Is Question

Mandatory : No

Two time-limited signals $g_1(t)$ and $g_2(t)$ are defined in the interval $[1, 3]$, and $[5, 7]$, respectively. Then, the convolution of the two signals is zero except for -----.

Options :

1. ✘ $1 < t < 7$

2. ✔ $6 < t < 10$

3. ✘ $5 < t < 7$

4. ✘ $3 < t < 5$

Question Number : 65 Question Id : 587587425 Display Question Number : Yes Is Question

Mandatory : No

Suppose that $g(t) = \delta(t)$. The pre-envelope of $g(t)$ is given by -----.

Options :

1. ✘ $\delta(t) + j\left(\frac{1}{t}\right)$

2. ✔ $\delta(t) + j\left(\frac{1}{\pi t}\right)$

3. ✘ $\delta(t) - j\left(\frac{1}{\pi t}\right)$

4. ✘ $\delta(t) - j\left(\frac{1}{t}\right)$

Question Number : 66 Question Id : 587587426 Display Question Number : Yes Is Question

Mandatory : No

Consider an exponentially damped sinusoidal signal $g(t) = \exp(-t)\sin t u(t)$, where $u(t)$ is the unit step function. The area under $g(t)$ is equal to -----.

Options :

1. ✘ 0.25

2. ✔ 0.5

3. ✘ 1

4. ✘ 0.75

Question Number : 67 Question Id : 587587427 Display Question Number : Yes Is Question

Mandatory : No

The following is/are true regarding autocorrelation function (ACF) $R(\tau)$ of a real-valued energy signal $g(t)$:

Options :

1. ✘ $R(\tau)$ is an even function of τ .

2. ✘ $R(\tau)$ at $\tau = 0$ denotes the area under the energy spectral density (ESD).

3. ✘ ACF and ESD form a Fourier transform pair.

All of the above options are true

4. ✔

Question Number : 68 Question Id : 587587428 Display Question Number : Yes Is Question

Mandatory : No

The Z-transform of $2^n u[n]$, where $u[n]$ is the unit step sequence, is given by -----.

Options :

1. ✘ $\frac{1}{1-2z^{-1}}, |z| < 2$

2. ✔ $\frac{1}{1-2z^{-1}}, |z| > 2$

3. ✘ $\frac{-1}{1-2z^{-1}}, |z| < 2$

4. ✘ $\frac{-1}{1-2z^{-1}}, |z| > 2$

Question Number : 69 Question Id : 587587429 Display Question Number : Yes Is Question

Mandatory : No

The Laplace transform of the two sided exponential decay $\exp(-|t|)$ is given by

Options :

1. ✔ $\frac{2}{1-s^2}, -1 < \text{Re}(s) < 1$

2. ✘ $\frac{2}{1+s^2}, -1 < \text{Re}(s) < 1$

3. ✘ $\frac{1}{1-s^2}, -1 < \text{Re}(s) < 1$

4. ✘ $\frac{1}{1+s^2}, -1 < \text{Re}(s) < 1$

Question Number : 70 Question Id : 587587430 Display Question Number : Yes Is Question

Mandatory : No

Consider the impulse responses $h_1(t) = \delta(t - 0.5)$ and $h_2(t) = \delta(t + 0.5)$ of two systems. Suppose that the systems are connected in cascade. The impulse response of the overall system is given by -----.

Options :

1. ✘ $h_{eq}(t) = \delta(t + 1)$

2. ✘ $h_{eq}(t) = \delta(t - 0.5)$

3. ✔ $h_{eq}(t) = \delta(t)$

4. ✘ $h_{eq}(t) = \delta(t - 1)$

Question Number : 71 Question Id : 587587431 Display Question Number : Yes Is Question

Mandatory : No

Integrating a unit step function twice results in a -----.

Options :

1. ✘ unit ramp function

2. ✘ unit delta function

3. ✔ unit parabolic function

4. ✘ unit doublet function

Question Number : 72 Question Id : 587587432 Display Question Number : Yes Is Question

Mandatory : No

A unity feedback system has transfer function $G(s) = 16/(s(s + 4))$. Its undamped natural frequency of oscillations is -----.

Options :

1. ✘ 16

2. ✔ 4

3. ✘ 2

4. ✘ 64

Question Number : 73 Question Id : 587587433 Display Question Number : Yes Is Question

Mandatory : No

The unit impulse response of a system is given by $0.25 \exp(-0.25t)$. Its transfer function is given by -----.

Options :

1. ✘ $1/(s+4)$

2. ✔ $1/(1+4s)$

3. ✘ $4/(4+s)$

4. ✘ $4/(1+4s)$

Question Number : 74 Question Id : 587587434 Display Question Number : Yes Is Question

Mandatory : No

The transfer function of a system is $9/(1+s)$. When operated as a unity feedback control system, the steady state error to a unit step input is equal to -----.

Options :

1. ✘ 0

2. ✘ Infinity

3. ✔ 0.1

4. ✘ $1/9$

Question Number : 75 Question Id : 587587435 Display Question Number : Yes Is Question

Mandatory : No

Consider the transfer function $GH = \frac{k(s+2)}{s^2(s+4)(s+9)}$. The bode gain is equal to -----.

Options :

1. ✘ k

2. ✔ k/18

3. ✘ 2 k

4. ✘ 18k

Question Number : 76 Question Id : 587587436 Display Question Number : Yes Is Question

Mandatory : No

Consider $GH = \frac{K}{s(s+2)^2}$. What value of K satisfies $|GH(j2)| = 2$?

Options :

1. ✔ $|K| = 32$

2. ✘ $|K| = 16$

3. ✘ $|K| = 8$

4. ✘ $|K| = 4$

Question Number : 77 Question Id : 587587437 Display Question Number : Yes Is Question

Mandatory : No

Suppose that $GH(j\omega) = \frac{2}{(j\omega+1)^3}$. The gain margin of the system is equal to -----.

Options :

1. ✘ 8

2. ✔ 4

3. ✘ 2

4. ✘ 16

Question Number : 78 Question Id : 587587438 Display Question Number : Yes Is Question

Mandatory : No

Suppose that $GH(j\omega) = \frac{1}{(j\omega+1)^3}$. The phase margin of the system is equal to -----.

Options :

1. ✘ 0 degree

2. ✔ 180 degrees

3. ✘ 90 degrees

4. ✘ 45 degrees

Question Number : 79 Question Id : 587587439 Display Question Number : Yes Is Question

Mandatory : No

Consider the transfer function $\frac{4}{5+2s+s^2}$. The resonant peak is equal to -----

Options :

1. ✔ 1

2. ✘ 1.25

3. ✘ 0.8

4. ✘ 0.25

Question Number : 80 Question Id : 587587440 Display Question Number : Yes Is Question Mandatory : No

Refer to the signal flow graph show. The transfer function is -----.

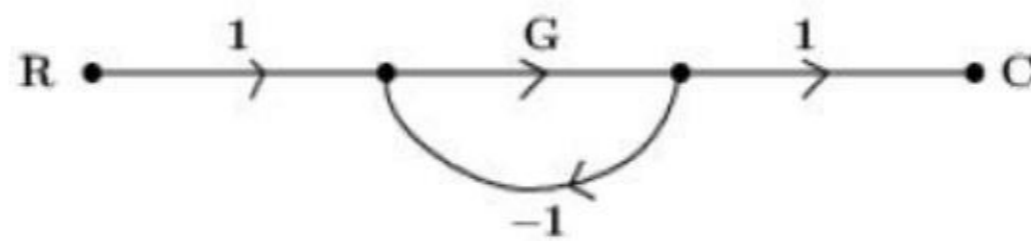

Options :

1. ✘ $1+G$

2. ✔ $\frac{1}{1+G}$

3. ✘ $1-G$

4. ✘ $\frac{1}{1-G}$

Question Number : 81 Question Id : 587587441 Display Question Number : Yes Is Question Mandatory : No

The unit of amplitude sensitivity K_a in amplitude modulation (AM) is -----.

Options :

1. ✘ volt

2. ✘ volt square

3. ✔ volt⁻¹

4. ✘ volt-ampere

Question Number : 82 Question Id : 587587442 Display Question Number : Yes Is Question

Mandatory : No

Consider amplitude modulation (AM). In an AM system, the maximum amplitude of the modulated signal is four times to its minimum amplitude. Then, the modulation index, is equal to -----.

Options :

1. ✘ 0.3

2. ✔ 0.6

3. ✘ 0.4

4. ✘ 0.5

Question Number : 83 Question Id : 587587443 Display Question Number : Yes Is Question

Mandatory : No

The range of carrier frequency in frequency modulation (FM) based radio broadcasting is -----

Options :

1. ✘ 535—1635 KHz

2. ✔ 88—108 MHz

3. ✘ 824—849 MHz

4. ✘ 2.4 — 5.8 GHz

Question Number : 84 Question Id : 587587444 Display Question Number : Yes Is Question

Mandatory : No

A superheterodyne receiver (SHRX) with an IF of 450 KHz is tuned to an incoming signal frequency 1200 KHz. The image frequency is -----.

Options :

1. ✘ 900 KHz

2. ✘ 750 KHz

3. ✘ 1650 KHz

4. ✔ 2100 KHz

Question Number : 85 Question Id : 587587445 Display Question Number : Yes Is Question

Mandatory : No

A tuned circuit resonates at 1 MHz. It has a quality factor of 100. Bandwidth between half-power points is -----.

Options :

1. ✔ 10 KHz

2. ✘ 100 KHz

3. ✘ 100 Hz

4. ✘ 1 MHz

Question Number : 86 Question Id : 587587446 Display Question Number : Yes Is Question

Mandatory : No

Which one of the following subsystem is NOT common in both FM and AM superheterodyne receivers?

Options :

1. ✘ RF amplifier
2. ✘ Mixer
3. ✘ IF amplifier
4. ✔ Slope detector

Question Number : 87 Question Id : 587587447 Display Question Number : Yes Is Question

Mandatory : No

A random variable (RV) Y has probability density function (pdf) given by $p_Y(y) = a \exp(-by), y \geq 0$, where a and b are constants. The relationship between a and b is -----.

Options :

1. ✘ $a = 2b$
2. ✔ $a = b$
3. ✘ $a = 0.5b$
4. ✘ $b = 0.25a$

Question Number : 88 Question Id : 587587448 Display Question Number : Yes Is Question

Mandatory : No

A WSS random process $X(t)$ whose mean value is 1, is applied to the input of an LTI system with impulse response $h(t) = \exp(-\pi t^2), t \in R$. The mean value of output $Y(t)$ of the system is equal to -----.

Options :

1. ✓ 1

2. ✗ 0.5

3. ✗ 2

4. ✗ 0.25

Question Number : 89 Question Id : 587587449 Display Question Number : Yes Is Question

Mandatory : No

Suppose that $R = 10^4 \Omega$, $T = 20^0 C$, and the bandwidth of observation is 1 MHz. What is the approximate value of root mean square (RMS) noise voltage?

(Note: Boltzmann's constant $K = 1.38 \times 10^{-23}$ joules per degree Kelvin.)

Options :

1. ✗ 127 microvolts

2. ✗ 12.7 millivolt

3. ✓ 12.7 microvolt

4. ✗ 12.7 nanovolt

Question Number : 90 Question Id : 587587450 Display Question Number : Yes Is Question

Mandatory : No

In a PCM system, uniform quantization is used. In it, each quantization level is encoded into 9 bits. The signal to quantization noise ratio is approximately equal to -----.

Options :

1. ✗ 24 dB

2. ✓ 56 dB

3. ✗ 48 dB

4. ✗ 512 dB

Question Number : 91 Question Id : 587587451 Display Question Number : Yes Is Question

Mandatory : No

Let $m(t) = bt$, where 'b' is a positive constant. The signal $m(t)$ is applied to a delta modulator with sampling duration T_s and step size δ . Slope-overload distortion occurs when -----.

Options :

1. ✓ $\delta < b T_s$

2. ✗ $\delta < b$

3. ✗ $\delta > b T_s$

4. ✗ $\delta > b$

Question Number : 92 Question Id : 587587452 Display Question Number : Yes Is Question

Mandatory : No

Four message signals each band-limited to 2.5 KHz are sampled at Nyquist rate. The resulting PAM samples are pulse code modulated and transmitted over a single channel after TDM. The number of quantization levels used is 512. The bit rate of the system is equal to -----.

Options :

1. ✗ 90 Kbps

2. ✓ 180 Kbps

3. ✘ 1 Mbps

4. ✘ 1.8 Mbps

Question Number : 93 Question Id : 587587453 Display Question Number : Yes Is Question

Mandatory : No

A continuous-time signal has voltage range -2 V to 2 V . The signal is sampled uniformly at Nyquist rate and uniformly quantized. If each quantization level is encoded to 8 bits per sample, the resulting signal have -----.

Options :

1. ✘ 256 levels of step size $1/128$

2. ✘ 128 levels of step size $1/64$

3. ✔ 256 levels of step size $1/64$

4. ✘ 256 levels of step size $1/256$

Question Number : 94 Question Id : 587587454 Display Question Number : Yes Is Question

Mandatory : No

Consider the transmission of binary PAM data over a baseband channel. The transmission bandwidth requirement is 72.0 KHz . Suppose that the transmitter uses raised cosine pulse shaping filter with roll-off factor β . Furthermore, the Nyquist bandwidth is equal to $\frac{1}{2T_b}$, where T_b denotes the bit duration. If the bit duration is 10 microseconds, β will be equal to -----.

Options :

1. ✘ 0.11

2. ✔ 0.44

3. ✘ 0.22

4. ✘ 0.88

Question Number : 95 Question Id : 587587455 Display Question Number : Yes Is Question

Mandatory : No

Consider a wideband FM receiver. When the modulation index is 5, the figure of merit of the FM receiver is equal to -----.

Options :

1. ✘ 3.75

2. ✔ 37.5

3. ✘ 1.5

4. ✘ 75

Question Number : 96 Question Id : 587587456 Display Question Number : Yes Is Question

Mandatory : No

Which of the following modulation scheme was used in the second generation narrowband digital cellular standard GSM?

Options :

1. ✘ Frequency shift keying

2. ✘ Phase shift keying

3. ✘ On-off keying

4. ✔ Gaussian minimum shift keying

Question Number : 97 Question Id : 587587457 Display Question Number : Yes Is Question

Mandatory : No

What is the approximate information capacity of the telephone channel when the received SNR is 30 dB and the channel bandwidth equal to 20 KHz? Assume AWGN channel.

Options :

1. ✓ 199 Kbps
2. ✗ 19.9 Kbps
3. ✗ 9.9 Kbps
4. ✗ 100 Kbps

Question Number : 98 Question Id : 587587458 Display Question Number : Yes Is Question

Mandatory : No

A communication system uses FSK transmitter (Tx) and coherent FSK receiver. The Tx transmits binary data at 2.5 Mbps using a sinusoidal carrier having amplitude 1 microvolt. Assuming AWGN channel with two-sided PSD equal to 10^{-20} W/Hz, the average probability of bit error is equal to -----, (Note: $erfc(\cdot)$ denotes the complementary function.)

Options :

1. ✓ $\frac{erfc(\sqrt{5})}{2}$
2. ✗ $\frac{erfc(\sqrt{10})}{2}$
3. ✗ $\frac{erfc(\sqrt{20})}{2}$
4. ✗ $\frac{erfc(5)}{2}$

Question Number : 99 Question Id : 587587459 Display Question Number : Yes Is Question

Mandatory : No

Suppose that a Direct sequence CDMA system has information bit rate of 1.8 Kbps and chip rate of 360 kbps. The processing gain in dB is approximately equal to -----.

(Use: $\log_{10}(2) = 0.3010$.)

Options :

1. ✘ 13 dB

2. ✔ 23 dB

3. ✘ 33 dB

4. ✘ 26 dB

Question Number : 100 Question Id : 587587460 Display Question Number : Yes Is Question

Mandatory : No

Consider the figure of merit (FoM) of single tone AM and wideband FM receivers. If the FoM of wideband FM is 72 times to the FoM of AM with 100% modulation, the modulation index of FM is -----.

Options :

1. ✘ 2

2. ✘ 4

3. ✘ 6

4. ✔ 8

Question Number : 101 Question Id : 587587461 Display Question Number : Yes Is Question

Mandatory : No

Consider a z- polarized electromagnetic wave propagation in vacuum, which is characterized by the following:

$$E = E_0 \exp\{j (\omega t - 30 x + 40 y)\} \hat{z}.$$

The wavelength of the wave is -----, (Assume SI units)

Options :

1. ✘ $\frac{\pi}{5}$

2. ✔ $\frac{\pi}{25}$

3. ✘ $\frac{\pi}{125}$

4. ✘ $\frac{\pi}{50}$

Question Number : 102 Question Id : 587587462 Display Question Number : Yes Is Question

Mandatory : No

Consider a 90 watt lamp. The intensity (in watt/m²) at a distance 1 meter is approximately -----,

(use: $\frac{1}{2\pi} \approx 0.16$.)

Options :

1. ✘ 72 watt/m²

2. ✘ 0.72 watt/m²

3. ✔ 7.2 watt/m²

4. ✘ 720 watt/m²

Question Number : 103 Question Id : 587587463 Display Question Number : Yes Is Question

Mandatory : No

For copper, assume conductivity of 60×10^6 mho/m and $\mu \approx \mu_0$. The skin depth at 0.1 GHz is approximately -----, (use: $\frac{1}{2\pi} \approx 0.16$ and $\frac{1}{\sqrt{6}} \approx 0.4$.)

Options :

1. ✘ $64 \mu m$
2. ✔ $6.4 \mu m$
3. ✘ $0.64 \mu m$
4. ✘ $0.064 \mu m$

Question Number : 104 Question Id : 587587464 Display Question Number : Yes Is Question

Mandatory : No

Suppose that for the glass-air interface, $n_1 = 1.5$, $n_2 = 1$. The critical angle (in degrees) is approximately-----.

Options :

1. ✘ 62°
2. ✘ 72°
3. ✘ 82°
4. ✔ 42°

Question Number : 105 Question Id : 587587465 Display Question Number : Yes Is Question

Mandatory : No

Suppose that a quarter-wave transformer has input impedance, denoted by Z_{in} . It has characteristic impedance of 150Ω . If the quarter-wave transformer is matching a $Z_{in} \Omega$ source with a 300Ω load, Z_{in} is -----.

Options :

1. ✘ 50Ω
2. ✔ 75Ω
3. ✘ 100Ω
4. ✘ 300Ω

Question Number : 106 Question Id : 587587466 Display Question Number : Yes Is Question

Mandatory : No

Suppose that the velocity of an electromagnetic wave in free space is 3×10^8 m/s. Further, the velocity in a medium with $\mu_r = 4$ is 3×10^8 m/s. The relative permittivity ϵ_r is equal to -----

Options :

1. ✘ 4.5
2. ✘ 4
3. ✔ 2.25
4. ✘ 2.5

Question Number : 107 Question Id : 587587467 Display Question Number : Yes Is Question

Mandatory : No

Suppose that VSWR is 1.25. Then, the magnitude of the reflection coefficient is -----.

Options :

1. ✘ $1/3$
2. ✔ $1/9$

3. ✘ $2/3$

4. ✘ $2/9$

Question Number : 108 Question Id : 587587468 Display Question Number : Yes Is Question

Mandatory : No

Suppose that the cutoff frequency of a rectangular waveguide in dominant mode is 4.5 GHz. The width of the waveguide is approximately -----.

Options :

1. ✘ 33.3 cm

2. ✔ 3.33 cm

3. ✘ 6.6 m

4. ✘ 0.66 m

Question Number : 109 Question Id : 587587469 Display Question Number : Yes Is Question

Mandatory : No

Consider the boundary between free space and glass. If a uniform plane wave with $E_m = 0.9$ volt/m and frequency 180 MHz is incident from free space normal to the glass ($\eta_2 \approx 0.5 \eta_1$), the reflection and transmission coefficients, respectively, are ----- . (Assume $\eta_1 = 120\pi \Omega$.)

Options :

1. ✘ $-1/9, 8/9$

2. ✘ $-1/6, 5/6$

3. ✔ $-1/3, 2/3$

4. ✘ $-2/3, 1/3$

Question Number : 110 Question Id : 587587470 Display Question Number : Yes Is Question

Mandatory : No

Consider a uniform plane wave of frequency 270 MHz travelling in an infinite, lossless medium having $\epsilon_r = 4.5$, $\mu_r = 2$, and $\sigma = 0$. The intrinsic impedance is -----.

Options :

1. ✘ 8π

2. ✔ 80π

3. ✘ 240π

4. ✘ 60π

Question Number : 111 Question Id : 587587471 Display Question Number : Yes Is Question

Mandatory : No

Let $A = \begin{bmatrix} -2 & 6 \\ -2 & 5 \end{bmatrix}$. The eigen values of $A^{-5} = (A^{-1})^5$ are

Options :

1. ✔ $1/32, 1$

2. ✘ $1/2, 2$

3. ✘ $32, 1$

4. ✘ $16, 4$

Question Number : 112 Question Id : 587587472 Display Question Number : Yes Is Question

Mandatory : No

The function $f(x, y) = x + y$ has absolute maximum on curve $x^2 + y^2 = 4, y \geq 0$ at

Options :

1. ✘ (2,0)
2. ✘ (-2,0)
3. ✘ (0,2)
4. ✔ $(\sqrt{2}, \sqrt{2})$

Question Number : 113 Question Id : 587587473 Display Question Number : Yes Is Question

Mandatory : No

Flux of $F = 4xz i - y^2 j + yz k$ outward through the surface of the cube from the first octant by the planes $x = 1, y = 1, z = 1$ is

Options :

1. ✘ 1
2. ✘ 0
3. ✔ 1.5
4. ✘ 4

Question Number : 114 Question Id : 587587474 Display Question Number : Yes Is Question

Mandatory : No

$\int_0^2 \int_{x^2}^{2x} f(x, y) dy dx$ is equal to

Options :

1. ✓ $\int_0^4 \int_{y/2}^{\sqrt{y}} f(x, y) dx dy$

2. ✗ $\int_0^4 \int_{\sqrt{y}}^{y/2} f(x, y) dx dy$

3. ✗ $\int_0^4 \int_{-\sqrt{y}}^{y/2} f(x, y) dx dy$

4. ✗ $\int_0^4 \int_{-\sqrt{y}}^y f(x, y) dx dy$

Question Number : 115 Question Id : 587587475 Display Question Number : Yes Is Question Mandatory : No

The solution of the initial value problem $4\frac{d^2y}{dx^2} - 8\frac{dy}{dx} + 3y = 0; y(0) = 2, \frac{dy}{dx}(0) = \frac{1}{2}$ is

Options :

1. ✓ $\frac{-1}{2}e^{\frac{3}{2}x} + \frac{5}{2}e^{\frac{1}{2}x}$

2. ✗ $\frac{1}{2}e^{\frac{3}{2}x} + \frac{5}{2}e^{\frac{1}{2}x}$

3. ✗ $\frac{1}{2}e^{\frac{3}{2}x} - \frac{5}{2}e^{\frac{1}{2}x}$

4. ✗ $-e^{\frac{3}{2}x} + e^{\frac{1}{2}x}$

Question Number : 116 Question Id : 587587476 Display Question Number : Yes Is Question Mandatory : No

The general solution of $\frac{dy}{dx} + \frac{2x+1}{x}y = e^{-2x}$ is

Options :

1. ✘ $\frac{1}{2}e^{-2x} + \frac{C}{x}e^{-2x}$

2. ✔ $\frac{1}{2}xe^{-2x} + \frac{C}{x}e^{-2x}$

3. ✘ $\frac{1}{2}e^{-2x}$

4. ✘ $\frac{1}{2} + \frac{C}{x}e^{-2x}$

Question Number : 117 Question Id : 587587477 Display Question Number : Yes Is Question

Mandatory : No

While watching IPL, you observe someone who is clearly supporting CSK (Chennai super kings) in the game. Assume that the probability that a randomly selected person in a typical local environment is born with in 150 km of Chennai is 0.05, and the chance that a person born with in 150 km of Chennai actually supports CSK is 0.7, the probability that a person not born with in 150 km of Chennai supports CSK with probability 0.1. Probability that supporters of CSK were actually born with in 150 km of Chennai is

Options :

1. ✘ $\frac{6}{26}$

2. ✘ $\frac{5}{26}$

3. ✘ $\frac{8}{26}$

4. ✔ $\frac{7}{26}$

Question Number : 118 Question Id : 587587478 Display Question Number : Yes Is Question

Mandatory : No

Let X be normal with $\mu = 5$ and $\sigma = 0.2$. The value of C such that $P[X \leq C] = 0.95$ is (use $\Phi(1.645) = 0.95$ from the cumulative distribution table for standard normal variable)

Options :

1. ✘ 4.25

2. ✘ 0.56

3. ✔ 5.329

4. ✘ 8.25

Question Number : 119 Question Id : 587587479 Display Question Number : Yes Is Question Mandatory : No

Let $f(z) = \frac{1}{z(z-2)^4}$ and $C: |z - 2| = 1$. The value of $\int_C f(z) dz$ is

Options :

1. ✘ $\frac{\pi i}{8}$

2. ✘ πi

3. ✘ $\frac{\pi i}{4}$

4. ✔ $-\frac{\pi i}{8}$

Question Number : 120 Question Id : 587587480 Display Question Number : Yes Is Question Mandatory : No

Consider $3 \frac{dy}{dx} + \sqrt{y} = e^{0.1x}$; $y(0.3) = 5$. The value of $y(0.6)$ using Euler's method with step size $h = 0.3$ is

Options :

1. ✖ 4.5605

2. ✔ 4.8794

3. ✖ 4.2501

4. ✖ 4.1464