

Q. 1 – Q. 5 carry one mark each.

Q.1 Out of the following four sentences, select the most suitable sentence with respect to grammar and usage.

- (A) I will not leave the place until the minister does not meet me.
- (B) I will not leave the place until the minister doesn't meet me.
- (C) I will not leave the place until the minister meet me.
- (D) I will not leave the place until the minister meets me.

Q.2 A rewording of something written or spoken is a _____.

- (A) paraphrase
- (B) paradox
- (C) paradigm
- (D) paraffin

Q.3 Archimedes said, "Give me a lever long enough and a fulcrum on which to place it, and I will move the world."

The sentence above is an example of a _____ statement.

- (A) figurative
- (B) collateral
- (C) literal
- (D) figurine

Q.4 If 'relftaga' means carefree, 'otaga' means careful and 'fertaga' means careless, which of the following could mean 'aftercare'?

- (A) zentaga
- (B) tagafer
- (C) tagazen
- (D) relffer

Q.5 A cube is built using 64 cubic blocks of side one unit. After it is built, one cubic block is removed from every corner of the cube. The resulting surface area of the body (in square units) after the removal is _____.

- (A) 56
- (B) 64
- (C) 72
- (D) 96

Q. 6 – Q. 10 carry two marks each.

- Q.6 A shaving set company sells 4 different types of razors, Elegance, Smooth, Soft and Executive. Elegance sells at Rs. 48, Smooth at Rs. 63, Soft at Rs. 78 and Executive at Rs. 173 per piece. The table below shows the numbers of each razor sold in each quarter of a year.

Quarter \ Product	Elegance	Smooth	Soft	Executive
Q1	27300	20009	17602	9999
Q2	25222	19392	18445	8942
Q3	28976	22429	19544	10234
Q4	21012	18229	16595	10109

Which product contributes the greatest fraction to the revenue of the company in that year?

- (A) Elegance (B) Executive (C) Smooth (D) Soft
- Q.7 Indian currency notes show the denomination indicated in at least seventeen languages. If this is not an indication of the nation's diversity, nothing else is.

Which of the following can be logically inferred from the above sentences?

- (A) India is a country of exactly seventeen languages.
 (B) Linguistic pluralism is the only indicator of a nation's diversity.
 (C) Indian currency notes have sufficient space for all the Indian languages.
 (D) Linguistic pluralism is strong evidence of India's diversity.
- Q.8 Consider the following statements relating to the level of poker play of four players **P**, **Q**, **R** and **S**.

- I. **P** always beats **Q**
 II. **R** always beats **S**
 III. **S** loses to **P** only sometimes
 IV. **R** always loses to **Q**

Which of the following can be logically inferred from the above statements?

- (i) **P** is likely to beat all the three other players
 (ii) **S** is the absolute worst player in the set
- (A) (i) only (B) (ii) only (C) (i) and (ii) (D) neither (i) nor (ii)
- Q.9 If $f(x) = 2x^7 + 3x - 5$, which of the following is a factor of $f(x)$?
- (A) (x^3+8) (B) $(x-1)$ (C) $(2x-5)$ (D) $(x+1)$

Q.10 In a process, the number of cycles to failure decreases exponentially with an increase in load. At a load of 80 units, it takes 100 cycles for failure. When the load is halved, it takes 10000 cycles for failure. The load for which the failure will happen in 5000 cycles is _____.

(A) 40.00

(B) 46.02

(C) 60.01

(D) 92.02

END OF THE QUESTION PAPER

Q. 1 – Q. 25 carry one mark each

- Q.1 Newton-Raphson method is to be used to find root of equation $3x - e^x + \sin x = 0$. If the initial trial value for the root is taken as 0.333, the next approximation for the root would be _____
(note: answer up to three decimal)
- Q.2 The type of partial differential equation $\frac{\partial^2 P}{\partial x^2} + \frac{\partial^2 P}{\partial y^2} + 3 \frac{\partial^2 P}{\partial x \partial y} + 2 \frac{\partial P}{\partial x} - \frac{\partial P}{\partial y} = 0$ is
(A) elliptic (B) parabolic (C) hyperbolic (D) none of these
- Q.3 If the entries in each column of a square matrix M add up to 1, then an eigenvalue of M is
(A) 4 (B) 3 (C) 2 (D) 1
- Q.4 Type II error in hypothesis testing is
(A) acceptance of the null hypothesis when it is false and should be rejected
(B) rejection of the null hypothesis when it is true and should be accepted
(C) rejection of the null hypothesis when it is false and should be rejected
(D) acceptance of the null hypothesis when it is true and should be accepted
- Q.5 The solution of the partial differential equation $\frac{\partial u}{\partial t} = \alpha \frac{\partial^2 u}{\partial x^2}$ is of the form
(A) $C \cos(kt) [C_1 e^{(\sqrt{k/\alpha})x} + C_2 e^{-(\sqrt{k/\alpha})x}]$
(B) $C e^{kt} [C_1 e^{(\sqrt{k/\alpha})x} + C_2 e^{-(\sqrt{k/\alpha})x}]$
(C) $C e^{kt} [C_1 \cos(\sqrt{k/\alpha}x) + C_2 \sin(-\sqrt{k/\alpha}x)]$
(D) $C \sin(kt) [C_1 \cos(\sqrt{k/\alpha}x) + C_2 \sin(-\sqrt{k/\alpha}x)]$

- Q.6 Consider the plane truss with load P as shown in the figure. Let the horizontal and vertical reactions at the joint B be H_B and V_B , respectively and V_C be the vertical reaction at the joint C .

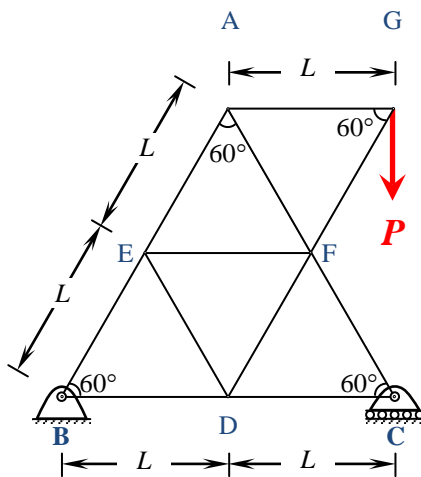

Which one of the following sets gives the correct values of V_B , H_B and V_C ?

- (A) $V_B = 0$; $H_B = 0$; $V_C = P$
- (B) $V_B = P/2$; $H_B = 0$; $V_C = P/2$
- (C) $V_B = P/2$; $H_B = P (\sin 60^\circ)$; $V_C = P/2$
- (D) $V_B = P$; $H_B = P (\cos 60^\circ)$; $V_C = 0$
- Q.7 In shear design of an RC beam, other than the allowable shear strength of concrete (τ_c), there is also an additional check suggested in IS 456-2000 with respect to the maximum permissible shear stress ($\tau_{c\max}$). The check for $\tau_{c\max}$ is required to take care of
- (A) additional shear resistance from reinforcing steel
- (B) additional shear stress that comes from accidental loading
- (C) possibility of failure of concrete by diagonal tension
- (D) possibility of crushing of concrete by diagonal compression
- Q.8 The semi-compact section of a laterally unsupported steel beam has an elastic section modulus, plastic section modulus and design bending compressive stress of 500 cm^3 , 650 cm^3 and 200 MPa , respectively. The design flexural capacity (expressed in kNm) of the section is _____
- Q.9 Bull's trench kiln is used in the manufacturing of
- (A) lime (B) cement (C) bricks (D) none of these
- Q.10 The compound which is largely responsible for initial setting and early strength gain of Ordinary Portland Cement is
- (A) C_3A (B) C_3S (C) C_2S (D) C_4AF

- Q.11 In the consolidated undrained triaxial test on a saturated soil sample, the pore water pressure is zero
- (A) during shearing stage only
 (B) at the end of consolidation stage only
 (C) both at the end of consolidation and during shearing stages
 (D) under none of the above conditions
- Q.12 A fine grained soil is found to be plastic in the water content range of 26-48%. As per Indian Standard Classification System, the soil is classified as
- (A) CL (B) CH (C) CL-ML (D) CI
- Q.13 A vertical cut is to be made in a soil mass having cohesion c , angle of internal friction ϕ , and unit weight γ . Considering K_a and K_p as the coefficients of active and passive earth pressures, respectively, the maximum depth of unsupported excavation is
- (A) $\frac{4c}{\gamma\sqrt{K_p}}$ (B) $\frac{2c\sqrt{K_p}}{\gamma}$ (C) $\frac{4c\sqrt{K_a}}{\gamma}$ (D) $\frac{4c}{\gamma\sqrt{K_a}}$
- Q.14 The direct runoff hydrograph in response to 5 cm rainfall excess in a catchment is shown in the figure. The area of the catchment (expressed in hectares) is _____

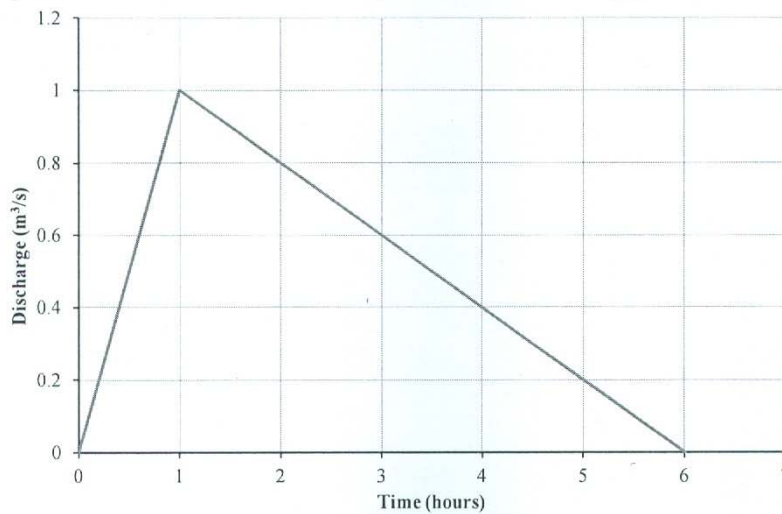

- Q.15 The type of flood routing (Group I) and the equation(s) used for the purpose (Group II) are given below.

Group I

- P Hydrologic flood routing
 Q Hydraulic flood routing

Group II

1. Continuity equation
 2. Momentum equation
 3. Energy equation

The correct match is

- (A) P - 1; Q - 1, 2 & 3
 (B) P - 1; Q - 1 & 2 only
 (C) P - 1 & 2; Q - 1 only
 (D) P - 1 & 2; Q - 1 & 2
- Q.16 The pre-jump Froude Number for a particular flow in a horizontal rectangular channel is 10. The ratio of sequent depths (i.e., post-jump depth to pre-jump depth) is _____

Q.17 Pre-cursors to photochemical oxidants are

- (A) NO_x, VOCs and sunlight
- (B) SO₂, CO₂ and sunlight
- (C) H₂S, CO and sunlight
- (D) SO₂, NH₃ and sunlight

Q.18 Crown corrosion in a reinforced concrete sewer is caused by:

- (A) H₂S
- (B) CO₂
- (C) CH₄
- (D) NH₃

Q.19 It was decided to construct a fabric filter, using bags of 0.45 m diameter and 7.5 m long, for removing industrial stack gas containing particulates. The expected rate of airflow into the filter is 10 m³/s. If the filtering velocity is 2.0 m/min, the minimum number of bags (rounded to nearest higher integer) required for continuous cleaning operation is

- (A) 27
- (B) 29
- (C) 31
- (D) 32

Q.20 Match the items in Group – I with those in Group – II and choose the right combination.

- | <u>Group - I</u> | <u>Group - II</u> |
|--------------------------------|--------------------------------|
| P. Activated sludge process | 1. Nitrifiers and denitrifiers |
| Q. Rising of sludge | 2. Autotrophic bacteria |
| R. Conventional nitrification | 3. Heterotrophic bacteria |
| S. Biological nitrogen removal | 4. Denitrifiers |

- (A) P-3, Q-4, R-2, S-1
- (B) P-2, Q-3, R-4, S-1
- (C) P-3, Q-2, R-4, S-1
- (D) P-1, Q-4, R-2, S-3

Q.21 During a forensic investigation of pavement failure, an engineer reconstructed the graphs P, Q, R and S, using partial and damaged old reports.

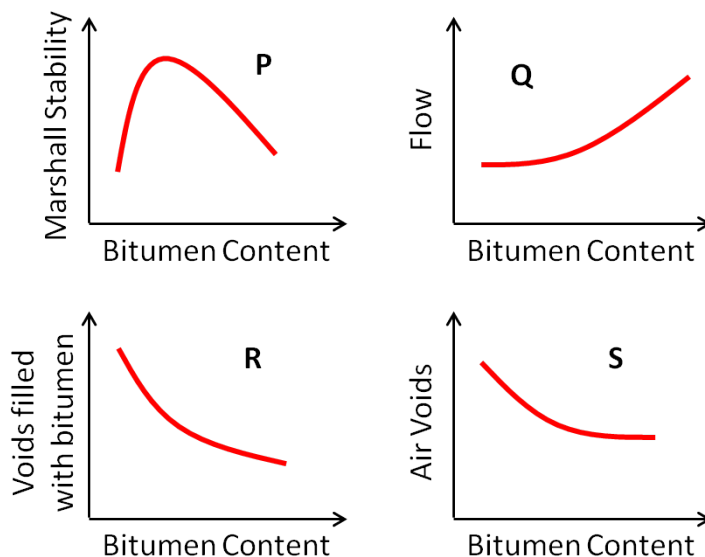

Theoretically plausible correct graphs according to the 'Marshall mixture design output' are

- (A) P, Q, R
- (B) P, Q, S
- (C) Q, R, S
- (D) R, S, P

Q.22 In a one-lane one-way homogeneous traffic stream, the observed average headway is 3.0 s. The flow (expressed in vehicles/hr) in this traffic stream is _____

- Q.23 The minimum number of satellites needed for a GPS to determine its position precisely is
- (A) 2 (B) 3 (C) 4 (D) 24
- Q.24 The system that uses the Sun as a source of electromagnetic energy and records the naturally radiated and reflected energy from the object is called
- (A) Geographical Information System
(B) Global Positioning System
(C) Passive Remote Sensing
(D) Active Remote Sensing
- Q.25 The staff reading taken on a workshop floor using a level is 0.645 m. The inverted staff reading taken to the bottom of a beam is 2.960 m. The reduced level of the floor is 40.500 m. The reduced level (expressed in m) of the bottom of the beam is
- (A) 44.105 (B) 43.460 (C) 42.815 (D) 41.145

Q. 26 – Q. 55 carry two marks each

- Q.26 Probability density function of a random variable X is given below

$$f(x) = \begin{cases} 0.25 & \text{if } 1 \leq x \leq 5 \\ 0 & \text{otherwise} \end{cases}$$

$P(X \leq 4)$ is

- (A) $\frac{3}{4}$ (B) $\frac{1}{2}$ (C) $\frac{1}{4}$ (D) $\frac{1}{8}$
- Q.27 The value of $\int_0^{\infty} \frac{1}{1+x^2} dx + \int_0^{\infty} \frac{\sin x}{x} dx$ is
- (A) $\frac{\pi}{2}$ (B) π (C) $\frac{3\pi}{2}$ (D) 1
- Q.28 The area of the region bounded by the parabola $y = x^2 + 1$ and the straight line $x + y = 3$ is
- (A) $\frac{59}{6}$ (B) $\frac{9}{2}$ (C) $\frac{10}{3}$ (D) $\frac{7}{6}$

- Q.29 The magnitudes of vectors **P**, **Q** and **R** are 100 kN, 250 kN and 150 kN, respectively as shown in the figure.

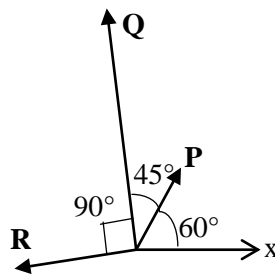

The respective values of the magnitude (in kN) and the direction (with respect to the x -axis) of the resultant vector are

- (A) 290.9 and 96.0° (B) 368.1 and 94.7° (C) 330.4 and 118.9° (D) 400.1 and 113.5°
- Q.30 The respective expressions for complimentary function and particular integral part of the solution of the differential equation $\frac{d^4 y}{dx^4} + 3\frac{d^2 y}{dx^2} = 108x^2$ are

- (A) $[c_1 + c_2 x + c_3 \sin \sqrt{3}x + c_4 \cos \sqrt{3}x]$ and $[3x^4 - 12x^2 + c]$
- (B) $[c_2 x + c_3 \sin \sqrt{3}x + c_4 \cos \sqrt{3}x]$ and $[5x^4 - 12x^2 + c]$
- (C) $[c_1 + c_3 \sin \sqrt{3}x + c_4 \cos \sqrt{3}x]$ and $[3x^4 - 12x^2 + c]$
- (D) $[c_1 + c_2 x + c_3 \sin \sqrt{3}x + c_4 \cos \sqrt{3}x]$ and $[5x^4 - 12x^2 + c]$

- Q.31 A 3 m long simply supported beam of uniform cross section is subjected to a uniformly distributed load of $w = 20$ kN/m in the central 1 m as shown in the figure.

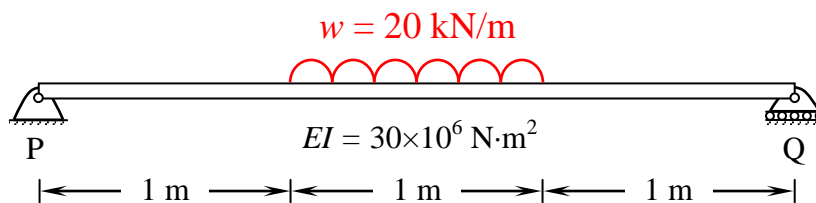

If the flexural rigidity (EI) of the beam is 30×10^6 N·m², the maximum slope (expressed in radians) of the deformed beam is

- (A) 0.681×10^{-7} (B) 0.943×10^{-7} (C) 4.310×10^{-7} (D) 5.910×10^{-7}

Q.32 Two beams PQ (fixed at P and with a roller support at Q, as shown in Figure I, which allows vertical movement) and XZ (with a hinge at Y) are shown in the Figures I and II respectively. The spans of PQ and XZ are L and 2L respectively. Both the beams are under the action of uniformly distributed load (W) and have the same flexural stiffness, EI (where, E and I respectively denote modulus of elasticity and moment of inertia about axis of bending). Let the maximum deflection and maximum rotation be $\delta_{\max 1}$ and $\theta_{\max 1}$, respectively, in the case of beam PQ and the corresponding quantities for the beam XZ be $\delta_{\max 2}$ and $\theta_{\max 2}$, respectively.

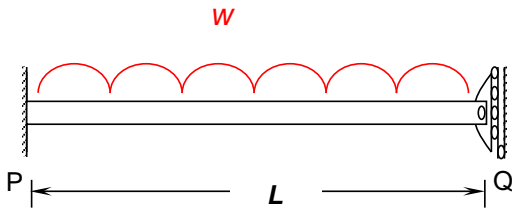

Figure I

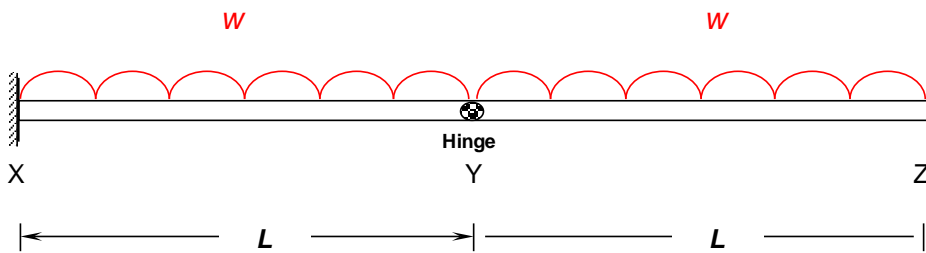
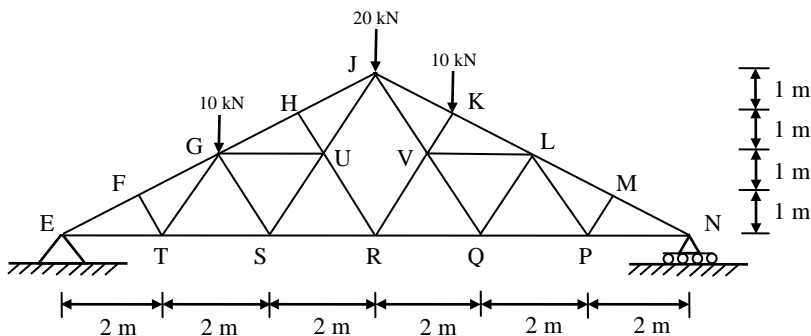

Figure II

Which one of the following relationships is true?

- (A) $\delta_{\max 1} \neq \delta_{\max 2}$ and $\theta_{\max 1} \neq \theta_{\max 2}$
- (B) $\delta_{\max 1} = \delta_{\max 2}$ and $\theta_{\max 1} \neq \theta_{\max 2}$
- (C) $\delta_{\max 1} \neq \delta_{\max 2}$ and $\theta_{\max 1} = \theta_{\max 2}$
- (D) $\delta_{\max 1} = \delta_{\max 2}$ and $\theta_{\max 1} = \theta_{\max 2}$

Q.33 A plane truss with applied loads is shown in the figure.



The members which do not carry any force are

- (A) FT, TG, HU, MP, PL
- (B) ET, GS, UR, VR, QL
- (C) FT, GS, HU, MP, QL
- (D) MP, PL, HU, FT, UR

- Q.34 A rigid member ACB is shown in the figure. The member is supported at A and B by pinned and guided roller supports, respectively. A force P acts at C as shown. Let R_{Ah} and R_{Bh} be the horizontal reactions at supports A and B, respectively, and R_{Av} be the vertical reaction at support A. Self-weight of the member may be ignored.

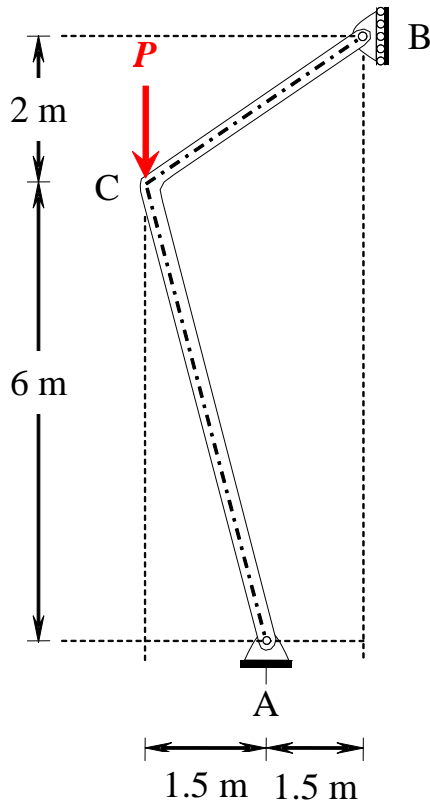

Which one of the following sets gives the correct magnitudes of R_{Av} , R_{Bh} and R_{Ah} ?

- (A) $R_{Av} = 0$; $R_{Bh} = \frac{1}{3}P$; and $R_{Ah} = \frac{2}{3}P$
- (B) $R_{Av} = 0$; $R_{Bh} = \frac{2}{3}P$; and $R_{Ah} = \frac{1}{3}P$
- (C) $R_{Av} = P$; $R_{Bh} = \frac{3}{8}P$; and $R_{Ah} = \frac{1.5}{8}P$
- (D) $R_{Av} = P$; $R_{Bh} = \frac{1.5}{8}P$; and $R_{Ah} = \frac{1.5}{8}P$
- Q.35 A reinforced concrete (RC) beam with width of 250 mm and effective depth of 400 mm is reinforced with Fe415 steel. As per the provisions of IS 456-2000, the minimum and maximum amount of tensile reinforcement (expressed in mm^2) for the section are, respectively
- (A) 250 and 3500 (B) 205 and 4000
- (C) 270 and 2000 (D) 300 and 2500
- Q.36 For M25 concrete with creep coefficient of 1.5, the long-term static modulus of elasticity (expressed in MPa) as per the provisions of IS:456-2000 is _____

Q.37 A propped cantilever of span L carries a vertical concentrated load at the mid-span. If the plastic moment capacity of the section is M_p , the magnitude of the collapse load is

- (A) $\frac{8M_p}{L}$ (B) $\frac{6M_p}{L}$ (C) $\frac{4M_p}{L}$ (D) $\frac{2M_p}{L}$

Q.38 Two plates are connected by fillet welds of size 10 mm and subjected to tension, as shown in the figure. The thickness of each plate is 12 mm. The yield stress and the ultimate tensile stress of steel are 250 MPa and 410 MPa, respectively. The welding is done in the workshop ($\gamma_{mw} = 1.25$).

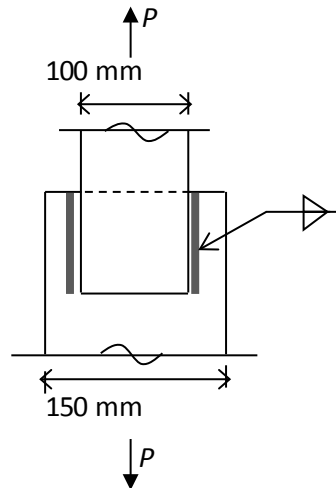

As per the Limit State Method of IS 800: 2007, the minimum length (rounded off to the nearest higher multiple of 5 mm) of each weld to transmit a force P equal to 270 kN (factored) is

- (A) 90 mm (B) 105 mm (C) 110 mm (D) 115 mm

Q.39 The Optimistic Time (O), Most likely Time (M) and Pessimistic Time (P) (in days) of the activities in the critical path are given below in the format O-M-P.

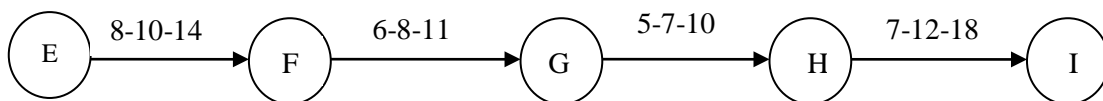

The expected completion time (in days) of the project is _____

Q.40 The porosity (n) and the degree of saturation (S) of a soil sample are 0.7 and 40%, respectively. In a 100 m^3 volume of the soil, the volume (expressed in m^3) of air is _____

- Q.41 A homogeneous gravity retaining wall supporting a cohesionless backfill is shown in the figure. The lateral active earth pressure at the bottom of the wall is 40 kPa.

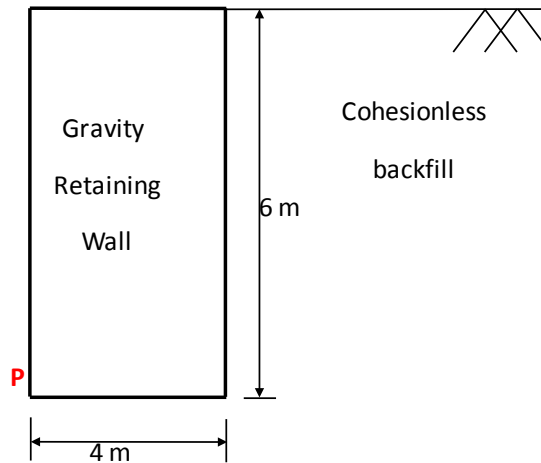

The minimum weight of the wall (expressed in kN per m length) required to prevent it from overturning about its toe (Point P) is

- (A) 120 (B) 180 (C) 240 (D) 360
- Q.42 An undisturbed soil sample was taken from the middle of a clay layer (i.e., 1.5 m below GL), as shown in figure. The water table was at the top of clay layer. Laboratory test results are as follows:

Natural water content of clay	:	25%
Preconsolidation pressure of clay	:	60 kPa
Compression index of clay	:	0.50
Recompression index of clay	:	0.05
Specific gravity of clay	:	2.70
Bulk unit weight of sand	:	17 kN/m ³

A compacted fill of 2.5 m height with unit weight of 20 kN/m³ is placed at the ground level.

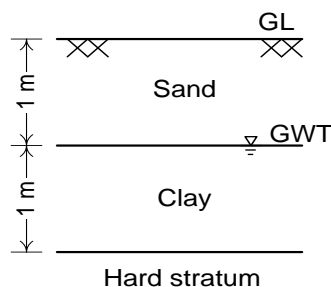

Assuming unit weight of water as 10 kN/m³, the ultimate consolidation settlement (expressed in mm) of the clay layer is _____

Q.43 A seepage flow condition is shown in the figure. The saturated unit weight of the soil $\gamma_{sat} = 18 \text{ kN/m}^3$. Using unit weight of water, $\gamma_w = 9.81 \text{ kN/m}^3$, the effective vertical stress (expressed in kN/m^2) on plane X-X is _____

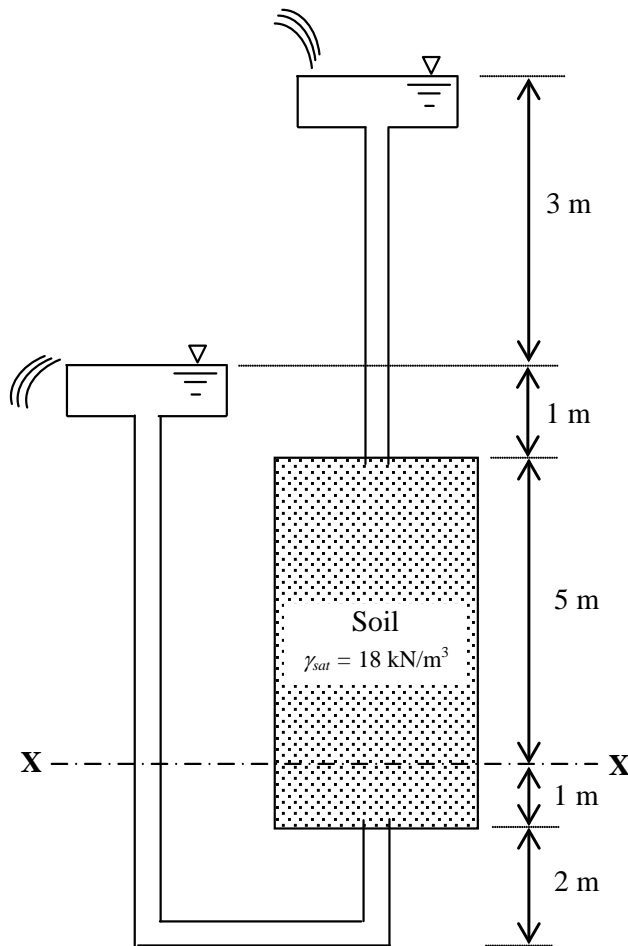

Q.44 A drained triaxial compression test on a saturated clay yielded the effective shear strength parameters as $c' = 15 \text{ kPa}$ and $\phi' = 22^\circ$. Consolidated Undrained triaxial test on an identical sample of this clay at a cell pressure of 200 kPa developed a pore water pressure of 150 kPa at failure. The deviator stress (expressed in kPa) at failure is _____

Q.45 A concrete gravity dam section is shown in the figure. Assuming unit weight of water as 10 kN/m^3 and unit weight of concrete as 24 kN/m^3 , the uplift force per unit length of the dam (expressed in kN/m) at **PQ** is _____

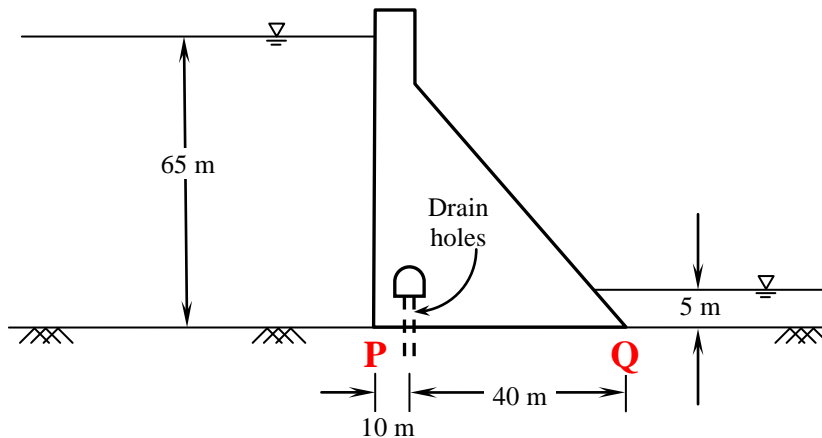

Q.46 Seepage is occurring through a porous media shown in the figure. The hydraulic conductivity values (k_1, k_2, k_3) are in m/day .

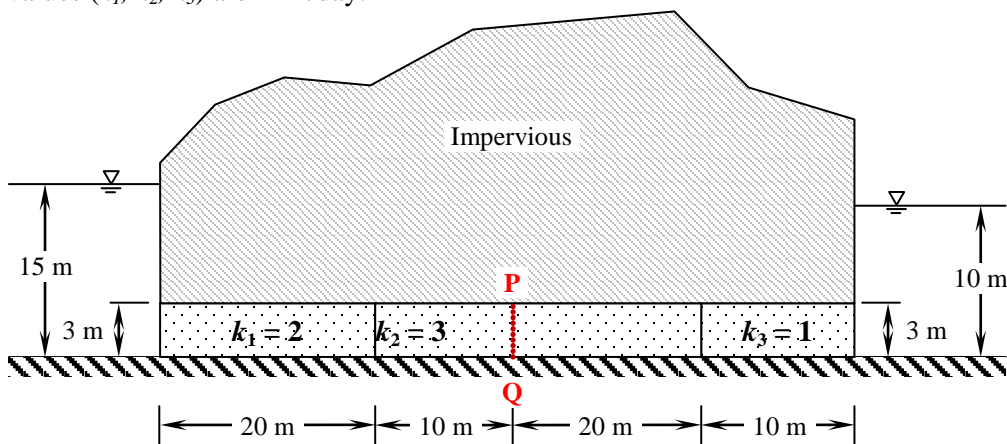

The seepage discharge (m^3/day per m) through the porous media at section **PQ** is

- (A) $\frac{7}{12}$ (B) $\frac{1}{2}$ (C) $\frac{9}{16}$ (D) $\frac{3}{4}$

Q.47 A 4 m wide rectangular channel, having bed slope of 0.001 carries a discharge of $16 \text{ m}^3/\text{s}$. Considering Manning's roughness coefficient = 0.012 and $g = 10 \text{ m/s}^2$, the category of the channel slope is

- (A) horizontal (B) mild (C) critical (D) steep

- Q.48 A sector gate is provided on a spillway as shown in the figure. Assuming $g = 10 \text{ m/s}^2$, the resultant force per meter length (expressed in kN/m) on the gate will be _____

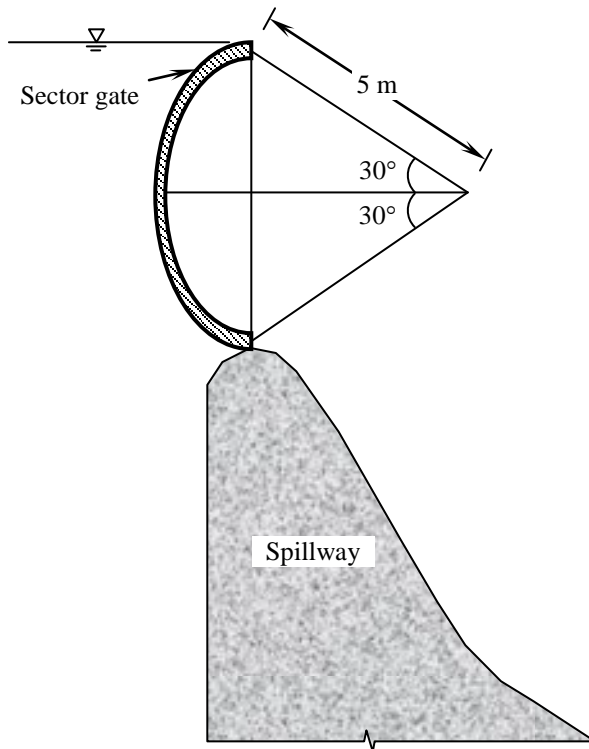

- Q.49 A hydraulically efficient trapezoidal channel section has a uniform flow depth of 2 m. The bed width (expressed in m) of the channel is _____
- Q.50 Effluent from an industry 'A' has a pH of 4.2. The effluent from another industry 'B' has double the hydroxyl (OH) ion concentration than the effluent from industry 'A'. pH of effluent from the industry 'B' will be _____
- Q.51 An electrostatic precipitator (ESP) with 5600 m^2 of collector plate area is 96 percent efficient in treating $185 \text{ m}^3/\text{s}$ of flue gas from a 200 MW thermal power plant. It was found that in order to achieve 97 percent efficiency, the collector plate area should be 6100 m^2 . In order to increase the efficiency to 99 percent, the ESP collector plate area (expressed in m^2) would be _____
- Q.52 The 2-day and 4-day BOD values of a sewage sample are 100 mg/L and 155 mg/L, respectively. The value of BOD rate constant (expressed in per day) is _____
- Q.53 A two lane, one-way road with radius of 50 m is predominantly carrying lorries with wheelbase of 5 m. The speed of lorries is restricted to be between 60 kmph and 80 kmph. The mechanical widening and psychological widening required at 60 kmph are designated as $w_{me,60}$ and $w_{ps,60}$, respectively. The mechanical widening and psychological widening required at 80 kmph are designated as $w_{me,80}$ and $w_{ps,80}$, respectively. The correct values of $w_{me,60}$, $w_{ps,60}$, $w_{me,80}$, $w_{ps,80}$, respectively are
- (A) 0.89 m, 0.50 m, 1.19 m, and 0.50 m (B) 0.50 m, 0.89 m, 0.50 m, and 1.19 m
 (C) 0.50 m, 1.19 m, 0.50 m, and 0.89 m (D) 1.19 m, 0.50 m, 0.89 m, and 0.50 m

- Q.54 While traveling along and against the traffic stream, a moving observer measured the relative flows as 50 vehicles/hr and 200 vehicles/hr, respectively. The average speeds of the moving observer while traveling along and against the stream are 20 km/hr and 30 km/hr, respectively. The density of the traffic stream (expressed in vehicles/km) is _____
- Q.55 The vertical angles subtended by the top of a tower T at two instrument stations set up at P and Q, are shown in the figure. The two stations are in line with the tower and spaced at a distance of 60 m. Readings taken from these two stations on a leveling staff placed at the benchmark (BM = 450.000 m) are also shown in the figure. The reduced level of the top of the tower T (expressed in m) is _____

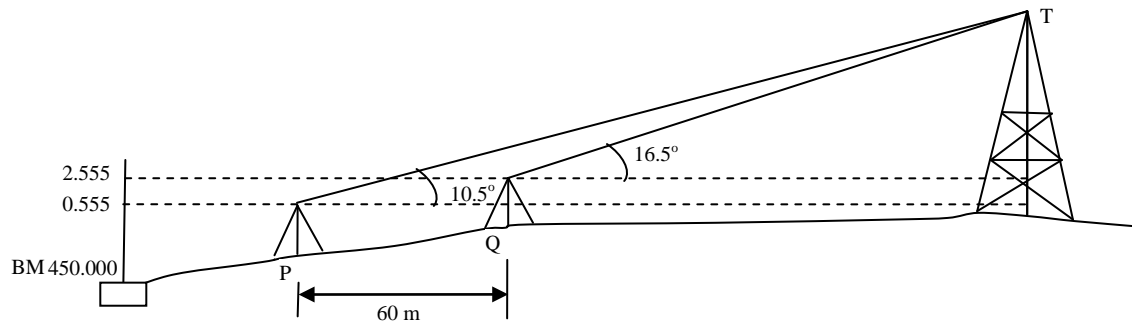

END OF THE QUESTION PAPER

Q. No	Type	Section	Key	Marks
1	MCQ	GA	D	1
2	MCQ	GA	A	1
3	MCQ	GA	A	1
4	MCQ	GA	C	1
5	MCQ	GA	D	1
6	MCQ	GA	B	2
7	MCQ	GA	D	2
8	MCQ	GA	D	2
9	MCQ	GA	B	2
10	MCQ	GA	B	2
1	NAT	CE-1	0.355 : 0.365	1
2	MCQ	CE-1	C	1
3	MCQ	CE-1	D	1
4	MCQ	CE-1	A	1
5	MCQ	CE-1	B	1
6	MCQ	CE-1	A	1
7	MCQ	CE-1	D	1
8	NAT	CE-1	99.9 : 100.1	1
9	MCQ	CE-1	C	1
10	MCQ	CE-1	B	1
11	MCQ	CE-1	B	1
12	MCQ	CE-1	D	1
13	MCQ	CE-1	D	1
14	NAT	CE-1	21.5 : 21.7	1
15	MCQ	CE-1	B	1
16	NAT	CE-1	13.6 : 13.7	1
17	MCQ	CE-1	A	1
18	MCQ	CE-1	A	1
19	MCQ	CE-1	B	1
20	MCQ	CE-1	A	1
21	MCQ	CE-1	B	1
22	NAT	CE-1	1199 : 1201	1
23	MCQ	CE-1	C	1
24	MCQ	CE-1	C	1
25	MCQ	CE-1	A	1
26	MCQ	CE-1	A	2
27	MCQ	CE-1	B	2
28	MCQ	CE-1	B	2
29	MCQ	CE-1	C	2
30	MCQ	CE-1	A	2
31	MCQ	CE-1	MTA	2
32	MCQ	CE-1	D	2
33	MCQ	CE-1	A	2
34	MCQ	CE-1	D	2
35	MCQ	CE-1	B	2
36	NAT	CE-1	9999 : 10001	2
37	MCQ	CE-1	B	2
38	MCQ	CE-1	B	2
39	NAT	CE-1	37 : 38	2

40	NAT	CE-1	41 : 43	2
41	MCQ	CE-1	A	2
42	NAT	CE-1	36 : 38	2
43	NAT	CE-1	65.3 : 65.6	2
44	NAT	CE-1	100 : 110	2
45	NAT	CE-1	10490 : 10510	2
46	MCQ	CE-1	B	2
47	MCQ	CE-1	B	2
48	NAT	CE-1	126 : 128	2
49	NAT	CE-1	2.29 : 2.32	2
50	NAT	CE-1	4.4 : 4.6	2
51	NAT	CE-1	8000 : 8040	2
52	NAT	CE-1	0.29 : 0.31	2
53	MCQ	CE-1	B	2
54	NAT	CE-1	2.9 : 3.1	2
55	NAT	CE-1	476.500 : 477.500	2