

**IN : INSTRUMENTATION ENGINEERING**

Duration : Three Hours

Maximum Marks : 100

**Read the following instructions carefully.**

1. This question paper contains **16** printed pages including pages for rough work. Please check all pages and report discrepancy, if any.
2. Write your registration number, your name and name of the examination centre at the specified locations on the right half of the **Optical Response Sheet (ORS)**
3. Using HB pencil, darken the appropriate bubble under each digit of your registration number and the letters corresponding to your paper code.
4. All questions in this paper are of objective type.
5. Questions must be answered on **Optical Response Sheet (ORS)** by darkening the appropriate bubble (marked A, B, C, D) using HB pencil against the question number on the left hand side of the ORS. **Each question has only one correct answer.** In case you wish to change an answer, erase the old answer completely. More than one answer bubbled against a question will be treated as an incorrect response.
6. There are a total of 60 questions carrying 100 marks. Questions 1 through 20 are 1-mark questions, questions 21 through 60 are 2-mark questions.
7. Questions 51 through 56 (3 pairs) are common data questions and question pairs (57, 58) and (59, 60) are linked answer questions. The answer to the second question of the above 2 pairs depends on the answer to the first question of the pair. If the first question in the linked pair is wrongly answered or is un-attempted, then the answer to the second question in the pair will not be evaluated.
8. Un-attempted questions will carry zero marks.
9. Wrong answers will carry **NEGATIVE** marks. For Q.1 to Q.20,  $\frac{1}{3}$  mark will be deducted for each wrong answer. For Q. 21 to Q. 56,  $\frac{2}{3}$  mark will be deducted for each wrong answer. The question pairs (Q.57, Q.58), and (Q.59, Q.60) are questions with linked answers. There will be negative marks only for wrong answer to the first question of the linked answer question pair i.e. for Q.57 and Q.59,  $\frac{2}{3}$  mark will be deducted for each wrong answer. There is no negative marking for Q.58 and Q.60.
10. Calculator (without data connectivity) is allowed in the examination hall.
11. Charts, graph sheets or tables are **NOT** allowed in the examination hall.
12. Rough work can be done on the question paper itself. Additionally, blank pages are given at the end of the question paper for rough work.



**Q. 1 – Q. 20 carry one mark each.**

- Q.1 If  $z = x + jy$ , where  $x$  and  $y$  are real, the value of  $|e^{jz}|$  is  
 (A) 1 (B)  $e^{\sqrt{x^2 + y^2}}$  (C)  $e^y$  (D)  $e^{-y}$
- Q.2 The value of  $\oint \frac{\sin z}{z} dz$ , where the contour of integration is a simple closed curve around the origin, is  
 (A) 0 (B)  $2\pi j$  (C)  $\infty$  (D)  $1/(2\pi j)$
- Q.3 Let  $\mathbf{P} \neq \mathbf{0}$  be a  $3 \times 3$  real matrix. There exist linearly independent vectors  $\mathbf{x}$  and  $\mathbf{y}$  such that  $\mathbf{P}\mathbf{x} = \mathbf{0}$  and  $\mathbf{P}\mathbf{y} = \mathbf{0}$ . The dimension of the range space of  $\mathbf{P}$  is  
 (A) 0 (B) 1 (C) 2 (D) 3
- Q.4 A sphere of unit radius is centered at the origin. The unit normal at a point  $(x, y, z)$  on the surface of the sphere is the vector  
 (A)  $(x, y, z)$  (B)  $(\frac{1}{\sqrt{3}}, \frac{1}{\sqrt{3}}, \frac{1}{\sqrt{3}})$  (C)  $(\frac{x}{\sqrt{3}}, \frac{y}{\sqrt{3}}, \frac{z}{\sqrt{3}})$  (D)  $(\frac{x}{\sqrt{2}}, \frac{y}{\sqrt{2}}, \frac{z}{\sqrt{2}})$
- Q.5 An LVDT is supplied with a sinusoidal voltage of amplitude 5 V and frequency 1 kHz. The output is connected to an ac voltmeter. The reading of the voltmeter is 1 V for a displacement of 1 mm from the null position. When the displacement is 1 mm in the opposite direction from the null position, the reading of the voltmeter is  
 (A)  $-1$  V (B)  $-0.2$  V (C) 1 V (D) 5 V
- Q.6 The circuit shown in the figure is

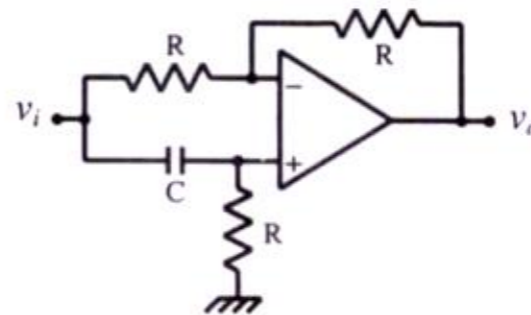

- (A) an all-pass filter (B) a bandpass filter  
 (C) a highpass filter (D) a lowpass filter

- Q.7 The diodes in the circuit shown are ideal. A voltage of 0 V represents logic 0 and +5 V represents logic 1. The logic function  $Z$  realized by the circuit for logic inputs  $X$  and  $Y$  is

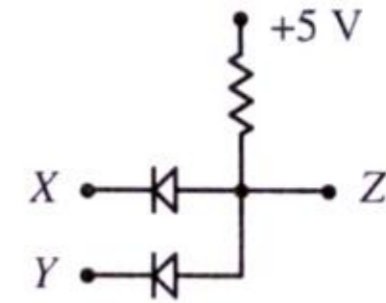

- (A)  $Z = X + Y$       (B)  $Z = X Y$       (C)  $Z = \overline{X + Y}$       (D)  $Z = \overline{X Y}$
- Q.8 The minimal sum-of-products expression for the logic function  $f$  represented by the given Karnaugh map is

	PQ	00	01	11	10
RS					
00		0	1	0	0
01		0	1	1	1
11		1	1	1	0
10		0	0	1	0

- (A)  $Q S + P \bar{R} S + P Q R + \bar{P} R S + \bar{P} Q \bar{R}$
- (B)  $\bar{Q} \bar{S} + \bar{P} R \bar{S} + \bar{P} \bar{Q} R + P \bar{R} \bar{S} + P \bar{Q} R$
- (C)  $\bar{P} R \bar{S} + \bar{P} \bar{Q} \bar{R} + P \bar{R} \bar{S} + P \bar{Q} R$
- (D)  $P \bar{R} S + P Q R + \bar{P} R S + \bar{P} Q \bar{R}$
- Q.9 In the figure shown, the initial state of  $Q$  is 0. The output is observed after the application of each clock pulse. The output sequence at  $Q$  is

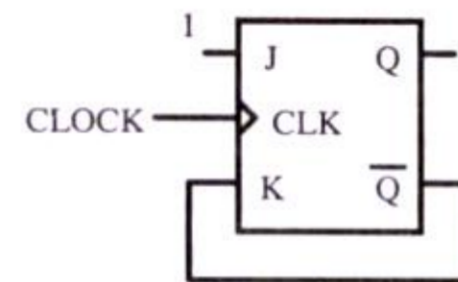

- (A) 0000...      (B) 1010...      (C) 1111...      (D) 1000...
- Q.10 The binary representation of the decimal number 1.375 is

- (A) 1.111      (B) 1.010
- (C) 1.011      (D) 1.001



- Q.11 Consider a system consisting of a microprocessor, memory, and peripheral devices connected by a common bus. During DMA data transfer, the microprocessor
- (A) only reads from the bus  
 (B) only writes to the bus  
 (C) both reads from and writes to the bus  
 (D) neither reads from nor writes to the bus
- Q.12 The fundamental period of  $x(t) = 2 \sin 2\pi t + 3 \sin 3\pi t$ , with  $t$  expressed in seconds, is
- (A) 1 s                      (B) 0.67 s                      (C) 2 s                      (D) 3 s
- Q.13 A linear time-invariant causal system has a frequency response given in polar form as  $\frac{1}{\sqrt{1+\omega^2}} \angle -\tan^{-1} \omega$ . For input  $x(t) = \sin t$ , the output is
- (A)  $\frac{1}{\sqrt{2}} \cos t$                       (B)  $\frac{1}{\sqrt{2}} \cos(t - \frac{\pi}{4})$                       (C)  $\frac{1}{\sqrt{2}} \sin t$                       (D)  $\frac{1}{\sqrt{2}} \sin(t - \frac{\pi}{4})$
- Q.14 A 50% duty cycle square wave with zero mean is used as a baseband signal in an ideal frequency modulator with a sinusoidal carrier of frequency  $\omega_c$ . The modulated signal is given as an input to an ideal phase demodulator (a circuit that produces an output proportional to the difference in phase of the modulated signal from that of the carrier). The output of the circuit is
- (A) a square wave  
 (B) a train of impulses with alternating signs  
 (C) a triangular wave  
 (D) a sinusoidal wave

- Q.15 The figure shows a periodic waveform to be displayed on a CRO. A trigger setting which ensures a stationary display is



- (A) level: 0.2 V, slope: - ve                      (B) level: 0.5 V, slope: - ve  
 (C) level: -0.2 V, slope: + ve                      (D) level: 1.8 V, slope: - ve

- Q.16 The input impedance of a CRO is equivalent to a  $1\text{ M}\Omega$  resistance in parallel with a  $45\text{ pF}$  capacitance. It is used with a compensated 10-to-1 attenuation probe. The effective input capacitance at the probe tip is
- (A)  $4.5\text{ pF}$  (B)  $5\text{ pF}$   
(C)  $45\text{ pF}$  (D)  $450\text{ pF}$
- Q.17 A galvanometer with internal resistance  $100\ \Omega$  and full-scale current  $1\text{ mA}$  is used to realize a dc voltmeter with a full scale range of  $1\text{ V}$ . The full scale range of this voltmeter can be extended to  $10\text{ V}$  by connecting an external resistance of value
- (A)  $9\text{ k}\Omega$  (B)  $9.9\text{ k}\Omega$   
(C)  $10\text{ k}\Omega$  (D)  $11\text{ k}\Omega$
- Q.18 A plant with a transfer function  $\frac{2}{s(s+3)}$  is controlled by a PI controller with  $K_p = 1$  and  $K_i \geq 0$  in a unity feedback configuration. The lowest value of  $K_i$  that ensures zero steady state error for a step change in the reference input is
- (A) 0 (B)  $1/3$   
(C)  $1/2$  (D) 1
- Q.19 A mass spectrometer is to be used to resolve peaks corresponding to  $\text{CO}^+$  and  $\text{N}_2^+$ . The atomic masses are  $^{12}\text{C} = 12.0000$ ,  $^{16}\text{O} = 15.9949$ , and  $^{14}\text{N} = 14.0031$  amu. The resolving power of the mass spectrometer should be at least
- (A) 250 (B) 350  
(C) 2500 (D) 3500
- Q.20 Assuming complete dissociation, the pH of a  $1\text{ mM}$  solution of  $\text{H}_2\text{SO}_4$  is closest to
- (A) 3 (B) 2.7  
(C) 2.4 (D) 2.1



**Q. 21 to Q. 60 carry two marks each.**

- Q.21 The eigenvalues of a  $(2 \times 2)$  matrix  $\mathbf{X}$  are  $-2$  and  $-3$ . The eigenvalues of the matrix  $(\mathbf{X} + \mathbf{I})^{-1}(\mathbf{X} + 5\mathbf{I})$  are  
 (A)  $-3, -4$  (B)  $-1, -2$  (C)  $-1, -3$  (D)  $-2, -4$
- Q.22 The matrix  $\mathbf{P} = \begin{bmatrix} 0 & 0 & 1 \\ 1 & 0 & 0 \\ 0 & 1 & 0 \end{bmatrix}$  rotates a vector about the axis  $\begin{bmatrix} 1 \\ 1 \\ 1 \end{bmatrix}$  by an angle of  
 (A)  $30^\circ$  (B)  $60^\circ$  (C)  $90^\circ$  (D)  $120^\circ$
- Q.23 A screening test is carried out to detect a certain disease. It is found that 12% of the positive reports and 15% of the negative reports are incorrect. Assuming that the probability of a person getting a positive report is 0.01, the probability that a person tested gets an incorrect report is  
 (A) 0.0027 (B) 0.0173 (C) 0.1497 (D) 0.2100
- Q.24 One of the roots of the equation  $x^3 = j$ , where  $j$  is the positive square root of  $-1$ , is  
 (A)  $j$  (B)  $\frac{\sqrt{3}}{2} + j\frac{1}{2}$  (C)  $\frac{\sqrt{3}}{2} - j\frac{1}{2}$  (D)  $-\frac{\sqrt{3}}{2} - j\frac{1}{2}$
- Q.25 The differential equation  $\frac{dx}{dt} = \frac{4-x}{\tau}$ , with  $x(0) = 0$ , and the constant  $\tau > 0$ , is to be numerically integrated using the forward Euler method with a constant integration time step  $T$ . The maximum value of  $T$  such that the numerical solution of  $x$  converges is  
 (A)  $\tau/4$  (B)  $\tau/2$  (C)  $\tau$  (D)  $2\tau$
- Q.26 A quantity  $x$  is calculated by using the formula  
 $x = (p - q)/r$ ,  
 The measured values are  $p = 9, q = 6, r = 0.5$ .  
 Assume that the measurement errors in  $p, q$  and  $r$  are independent. The absolute maximum error in the measurement of each of the three quantities is  $\epsilon$ . The absolute maximum error in the calculated value of  $x$  is  
 (A)  $\epsilon$  (B)  $2\epsilon$  (C)  $3\epsilon$  (D)  $16\epsilon$

Q.27 The response of a first order measurement system to a unit step input is  $1 - e^{-0.5t}$ , where  $t$  is in seconds. A ramp of 0.1 units per second is given as the input to this system. The error in the measured value after transients have died down is

- (A) 0.02 units      (B) 0.1 units      (C) 0.2 units      (D) 1 unit

Q.28 The source network S is connected to the load network L as shown by dashed lines.

The power transferred from S to L would be maximum when  $R_L$  is

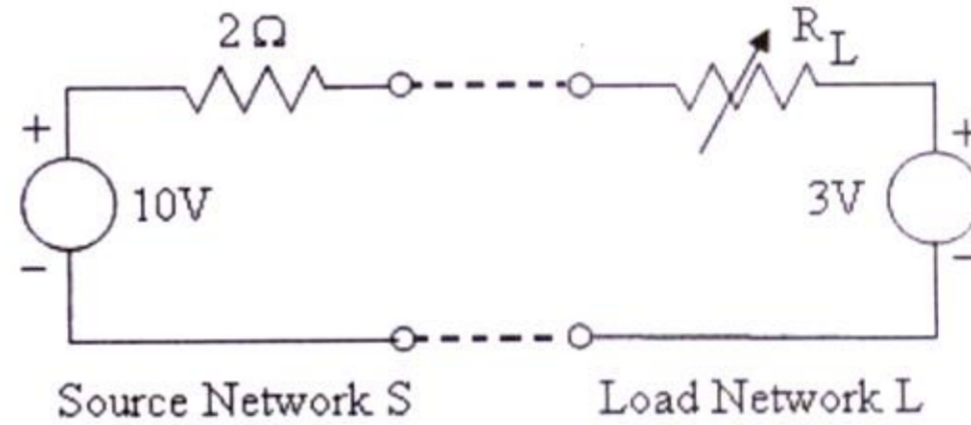

- (A)  $0 \Omega$       (B)  $0.6 \Omega$       (C)  $0.8 \Omega$       (D)  $2 \Omega$

Q.29 A stroboscopic system is used for measuring the speed of a rotating shaft. The shaft has one target mark on it. The maximum strobe rate at which synchronism is achieved is  $r_1$  flashes per minute. The next lower flash rate at which synchronism is achieved is  $r_2$  flashes per minute. The speed of the shaft in rpm is

- (A)  $\frac{r_1 r_2}{r_1 - r_2}$       (B)  $\frac{r_1 r_2}{r_1 + r_2}$       (C)  $\frac{r_2^2}{r_1 + r_2}$       (D)  $\frac{r_1^2}{r_1 + r_2}$

Q.30 The figure shows the cross-sectional diagram of an orifice flow meter with an orifice radius  $R$ . Point 'a' is  $30R$  upstream while points 'b' and 'c' are  $0.8R$  and  $30R$  downstream from the orifice respectively. The pressures at points a, b and c are  $P_a$ ,  $P_b$  and  $P_c$  respectively. Then

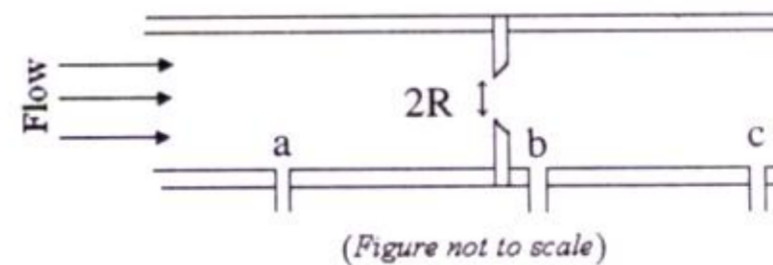

- (A)  $P_c > P_b > P_a$       (B)  $P_b > P_c > P_a$   
 (C)  $P_a > P_b > P_c$       (D)  $P_a > P_c > P_b$



Q.31 The values of the material constant  $\beta$  for thermistors P and Q are 4000 K and 3000 K, respectively. The resistance of each thermistor at 298 K is 2 k $\Omega$ . At 373 K the ratio of the resistance of thermistor P to that of thermistor Q will be closest to

- (A) 1.33 (B) 1.00  
(C) 0.75 (D) 0.50

Q.32 Four strain gauges are fixed on a cylindrical shaft to measure torque, as shown in the figure.

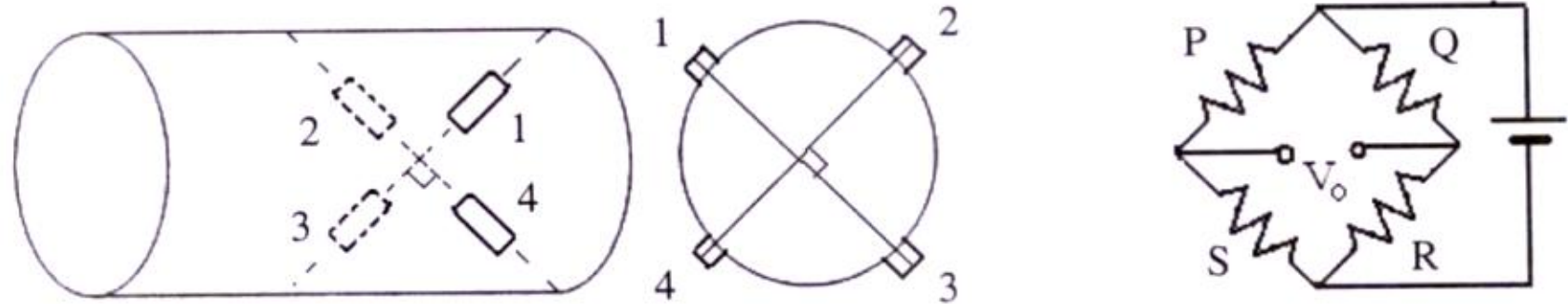

A correct way to place these gauges in the bridge is

- (A) P-1, Q-2, R-3, S-4 (B) P-1, Q-3, R-2, S-4  
(C) P-3, Q-1, R-2, S-4 (D) P-2, Q-1, R-3, S-4

Q.33 In the circuit shown, the Zener diode has ideal characteristics and a breakdown voltage of 3.2 V. The output voltage  $V_o$  for an input voltage  $V_i = +1$  V is closest to

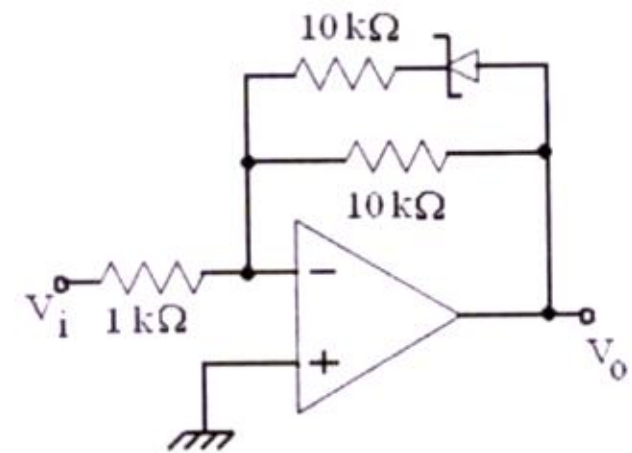

- (A) -10 V (B) -6.6 V  
(C) -5 V (D) -3.2 V

Q.34 The input resistance of the circuit shown in the figure, assuming an ideal op amp, is

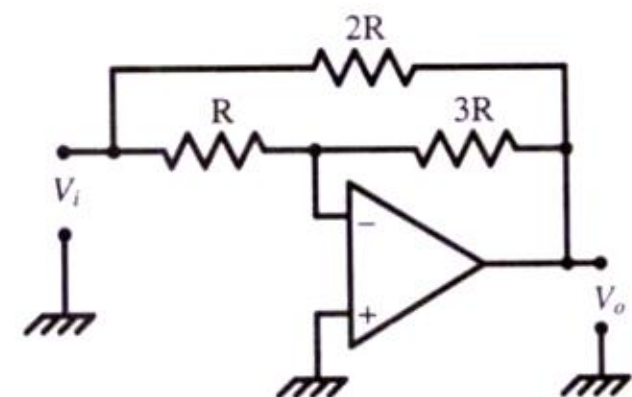

- (A)  $R/3$  (B)  $2R/3$   
(C)  $R$  (D)  $4R/3$



- Q.35 In the circuit shown in the figure, the switch S has been in Position 1 for a long time. It is then moved to Position 2. Assume the Zener diodes to be ideal. The time delay between the switch moving to Position 2 and the transition in the output voltage  $V_o$  is

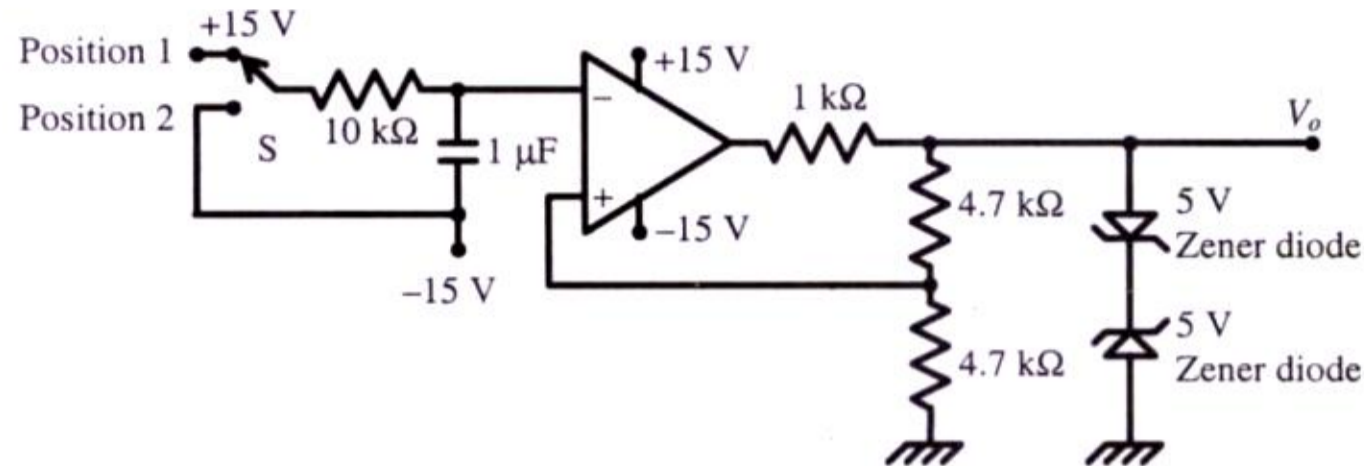

- (A) 5.00 ms      (B) 8.75 ms      (C) 10.00 ms      (D) 13.75 ms

Q.36

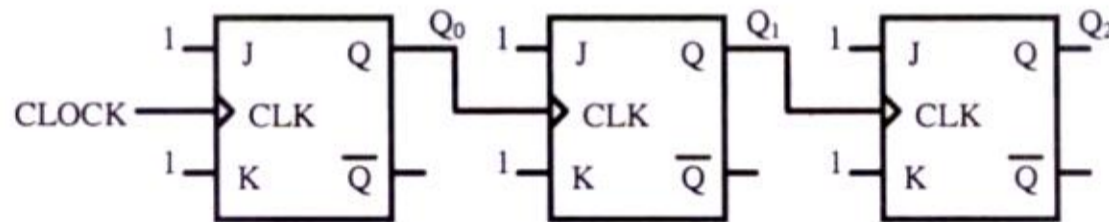

The figure above shows a 3-bit ripple counter, with  $Q_2$  as the MSB. The flip-flops are rising-edge triggered. The counting direction is

- (A) always down  
 (B) always up  
 (C) up or down depending on the initial state of  $Q_0$  only  
 (D) up or down depending on the initial states of  $Q_2$ ,  $Q_1$  and  $Q_0$
- Q.37 An 8-bit ADC, with 2's complement output, has a nominal input range of  $-2$  V to  $+2$  V. It generates a digital code of 00H for an analog input in the range  $-7.8125$  mV to  $+7.8125$  mV. An input of  $-1.5$  V will produce a digital output of
- (A) 90H      (B) 96H      (C) 9BH      (D) A0H

- Q.38 The following is an assembly language program for 8085 microprocessors :

Address	Instruction Code	Mnemonic
1000H	3E 06	MVI A, 06H
1002H	C6 70	ADI 70H
1004H	32 07 10	STA 1007H
1007H	AF	XRA A
1008H	76	HLT

When this program halts, the accumulator contains

- (A) 00H      (B) 06H      (C) 70H      (D) 76H

Q.39 For input  $x(t)$ , an ideal impulse sampling system produces the output

$$y(t) = \sum_{k=-\infty}^{\infty} x(kT)\delta(t - kT) \text{ where } \delta(t) \text{ is the Dirac delta function.}$$

The system is

- (A) nonlinear and time invariant
- (B) nonlinear and time varying
- (C) linear and time invariant
- (D) linear and time varying

Q.40 The root mean squared value of  $x(t) = 3 + 2 \sin(t) \cos(2t)$

- (A)  $\sqrt{3}$
- (B)  $\sqrt{8}$
- (C)  $\sqrt{10}$
- (D)  $\sqrt{11}$

Q.41 An analog signal is sampled at 9 kHz. The sequence so obtained is filtered by an FIR filter with transfer function  $H[z] = 1 - z^{-6}$ . One of the analog frequencies for which the magnitude response of the filter is zero is

- (A) 0.75 kHz
- (B) 1 kHz
- (C) 1.5 kHz
- (D) 2 kHz

Q.42 The transfer function  $H(z)$  of a fourth-order linear phase FIR system is given by

$$H(z) = (1 + 2z^{-1} + 3z^{-2})G(z).$$

Then  $G(z)$  is

- (A)  $3 + 2z^{-1} + z^{-2}$
- (B)  $1 + \frac{1}{2}z^{-1} + \frac{1}{3}z^{-2}$
- (C)  $\frac{1}{3} + 2z^{-1} + z^{-2}$
- (D)  $1 + 2z + 3z^2$

Q.43 The dc potentiometer shown in the figure has a working current of 10 mA with switch S open. Let  $R_g + R_1 = 100 \Omega$ . The galvanometer G can only detect currents greater than  $10 \mu\text{A}$ . The maximum percentage error in the measurement of the unknown emf  $E_x$  as calculated from the slider position shown is closest to

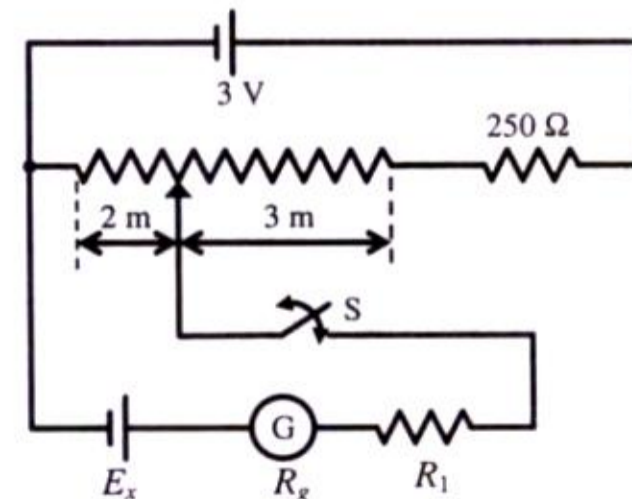

- (A) 0.3
- (B) 0.5
- (C) 0.6
- (D) 1.0



- Q.44 A filter is represented by the signal flow graph shown in the figure. Its input is  $x(t)$  and output is  $y(t)$ . The transfer function of the filter is

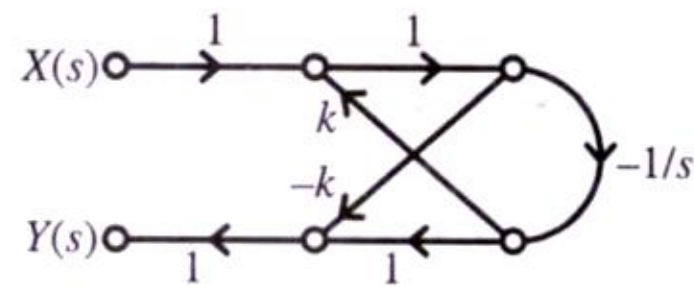

- (A)  $\frac{-(1+ks)}{s+k}$  (B)  $\frac{(1+ks)}{s+k}$   
 (C)  $\frac{-(1-ks)}{s+k}$  (D)  $\frac{(1-ks)}{s+k}$
- Q.45 A unity feedback control loop with an open loop transfer function of the form  $\frac{K}{s(s+a)}$  has a gain crossover frequency of 1 rad/s and a phase margin of  $60^\circ$ . If an element having a transfer function  $\frac{s-\sqrt{3}}{s+\sqrt{3}}$  is inserted into the loop, the phase margin will become

- (A)  $0^\circ$  (B)  $30^\circ$  (C)  $45^\circ$  (D)  $60^\circ$

- Q.46 A linear time-invariant single-input single-output system has a state space model given by

$$\frac{dx}{dt} = \mathbf{F} \mathbf{x} + \mathbf{G} u$$

$$y = \mathbf{H} \mathbf{x}$$

$$\text{where } \mathbf{F} = \begin{bmatrix} 0 & 1 \\ -4 & -2 \end{bmatrix}; \mathbf{G} = \begin{bmatrix} 0 \\ 1 \end{bmatrix}; \mathbf{H} = [1 \ 0].$$

Here  $\mathbf{x}$  is the state vector,  $u$  is the input, and  $y$  is the output.

The damping ratio of the system is

- (A) 0.25 (B) 0.5 (C) 1 (D) 2
- Q.47 A unity feedback system has the transfer function
- $$\frac{K(s+b)}{s^2(s+20)}$$
- The value of  $b$  for which the loci of all the three roots of the closed loop characteristic equation meet at a single point is
- (A)  $\frac{10}{9}$  (B)  $\frac{20}{9}$  (C)  $\frac{30}{9}$  (D)  $\frac{40}{9}$

- Q.48 A standard three-lead frontal plane ECG is taken of a person with a normal heart. The peak amplitude of the R-wave is
- (A) greatest in lead I  
 (B) greatest in lead II  
 (C) greatest in lead III  
 (D) equal in all the leads
- Q.49 The operating voltage of an X-ray tube is changed from 40 kV to 50 kV. The resulting change in the shortest wavelength generated is
- (A) +20 %                      (B) -20 %                      (C) +25 %                      (D) -36 %
- Q.50 In a pulsed ultrasound imaging system, a single 5 MHz crystal is used both as source and as detector. Bursts of at least 20 cycles are needed for acceptable image quality. The velocity of sound in the tissue being imaged is 1500 m/s. The minimum distance of the objects to be imaged should be
- (A) 12 mm                      (B) 6 mm                      (C) 3 mm                      (D) 1 mm

### Common Data Questions

#### Common Data for Questions 51 and 52 :

The figure shows a sample-and-hold circuit using a MOSFET as a switch. The threshold voltage of the MOSFET is +2 V. It has zero leakage current in the off state. Assume that the capacitor is ideal.

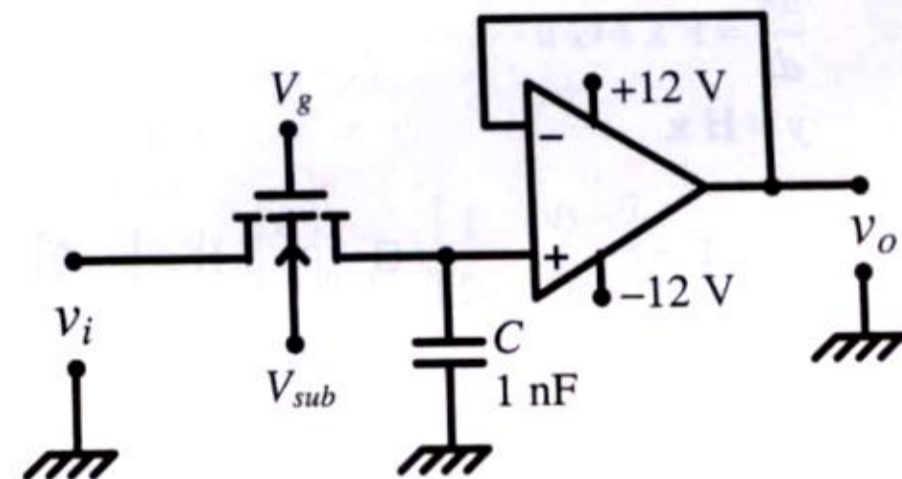

- Q.51 The input voltage  $V_i$  ranges from -5 V to +5 V. Appropriate values of  $V_{sub}$ , of  $V_g$  during sampling, and of  $V_g$  during hold are, respectively,
- (A) +12 V,  $\geq +7$  V, and  $\leq -3$  V                      (B) -12 V,  $\geq +3$  V, and  $\leq -7$  V  
 (C) +12 V,  $\geq +3$  V, and  $\leq -7$  V                      (D) -12 V,  $\geq +7$  V, and  $\leq -3$  V
- Q.52 The circuit is used at a sampling rate of 1 kHz, with an A/D converter having a conversion time of 200  $\mu$ s. The op amp has an input bias current of 10 nA. The maximum hold error is
- (A) 1 mV                      (B) 2 mV                      (C) 5 mV                      (D) 10 mV



**Common Data for Questions 53 and 54 :**

The circuit shown in the figure uses three identical transistors with  $V_{BE} = 0.7 \text{ V}$  and  $\beta = 100$ .

Given  $R_1 = R_2 = R_3 = 1 \text{ k}\Omega$ ,  $kT/q_e = 25 \text{ mV}$ . The collector current of transistor  $Q_3$  is  $2 \text{ mA}$ .

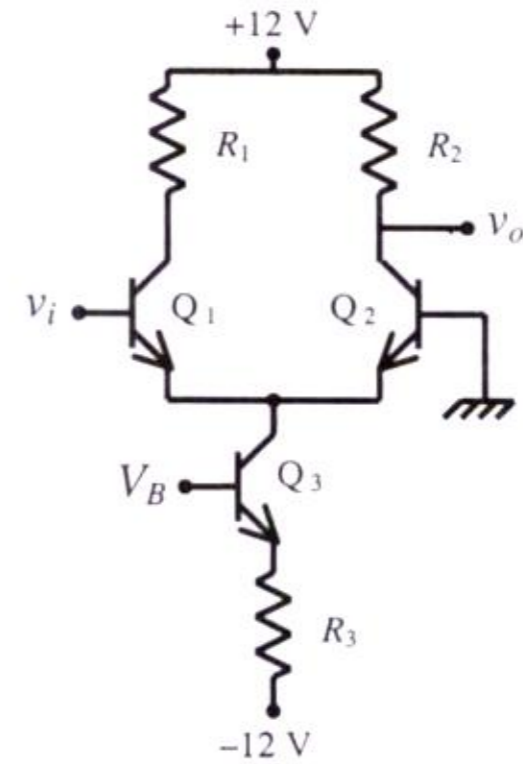

- Q.53 The bias voltage  $V_B$  at the base of the transistor  $Q_3$  is approximately  
 (A)  $-9.3 \text{ V}$  (B)  $-10.0 \text{ V}$  (C)  $-10.3 \text{ V}$  (D)  $-11.0 \text{ V}$
- Q.54 The small-signal voltage gain of the circuit is  
 (A)  $-20$  (B)  $-40$   
 (C)  $20$  (D)  $40$

**Common Data for Questions 55 and 56 :**

The figure shows an arrangement for measuring small angular displacements in a vertical plane. A non-conducting tube of length  $2l$  and rectangular cross section (width  $w$ , height  $d$ ) is bent along an arc of a circle with radius  $R \gg d$ , centered at P. Four electrode plates of length  $l$  and width  $w$  are placed to form two curved parallel plate capacitors  $C_1$  and  $C_2$  with a negligible gap between them. The tube contains water with an air bubble of rectangular cross section (width  $w$ , height  $d$ ) and length  $l/4$ . The capacitors are connected in a bridge circuit as shown in the figure, where the bridge has ac excitation  $v_i$ . Angular displacement  $\Delta\theta$  occurs about the point P.

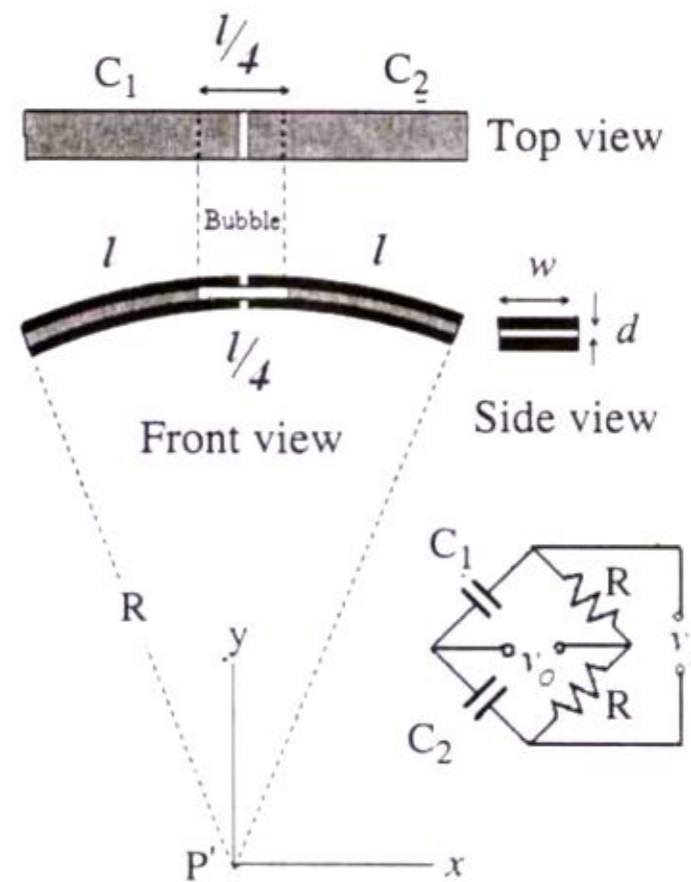

- Q.55 The range of angular displacement (in radians) this system can measure is  
 (A)  $-\frac{l}{8R}$  to  $+\frac{l}{8R}$  (B)  $-\frac{l}{4R}$  to  $+\frac{l}{4R}$   
 (C)  $-\frac{3l}{4R}$  to  $+\frac{l}{4R}$  (D)  $-\frac{l}{R}$  to  $+\frac{l}{R}$



- Q.56 The sensitivity  $\frac{v_o/v_i}{\Delta\theta}$  is
- (A) inversely proportional to  $R$  and  $l$   
 (B) inversely proportional to  $R$  and directly proportional to  $l$   
 (C) directly proportional to  $R$  and  $l$   
 (D) directly proportional to  $R$  and inversely proportional to  $l$

### Linked Answer Questions

#### Statement for Linked Answer Questions 57 and 58 :

A disturbance input  $d(t)$  is injected into the unity feedback control loop shown in the figure. Take the reference input  $r(t)$  to be a unit step.

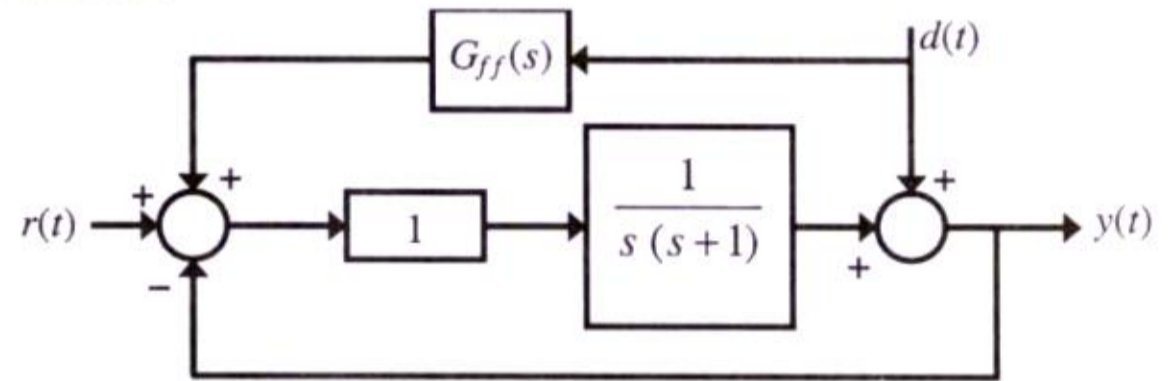

- Q.57 If the disturbance is measurable, its effect on the output can be minimized significantly using a feedforward controller  $G_{ff}(s)$ . To eliminate the component of the output due to  $d(t) = \sin t$ ,  $G_{ff}(j\omega)|_{\omega=1}$  should be
- (A)  $\frac{1}{\sqrt{2}} \angle -\frac{3\pi}{4}$       (B)  $\frac{1}{\sqrt{2}} \angle \frac{\pi}{4}$       (C)  $\sqrt{2} \angle \pi$       (D)  $\sqrt{2} \angle -\frac{\pi}{4}$
- Q.58 Let  $G_{ff}(s)$  be a PD controller. If  $d(t) = \sin 2t$ , the amplitude of the frequency component of  $y(t)$  due to  $d(t)$  is

- (A)  $\sqrt{\frac{5}{13}}$       (B)  $\sqrt{\frac{9}{13}}$       (C)  $\sqrt{\frac{17}{13}}$       (D)  $\sqrt{\frac{20}{13}}$

#### Statement for Linked Answer Questions 59 and 60 :

A Michelson interferometer illuminated with a source of central wavelength  $\lambda_0$  and spectral width  $\Delta\lambda$  is adjusted for equal path difference for the beams returning from the two mirrors. When one of the mirrors is moved by a distance of 0.1 mm from this position, 300 fringes move past the field of view. When the mirror is moved further, the fringes completely disappear when the mirror is approximately 4 cm from the initial position.

- Q.59 The central wavelength of the source is
- (A) 540 nm      (B) 632.8 nm      (C) 667 nm      (D) 720 nm
- Q.60 The spectral width of the source  $\Delta\lambda$  is approximately
- (A) 0.0056 nm      (B) 0.0100 nm      (C) 0.0500 nm      (D) 0.1000 nm

**END OF THE QUESTION PAPER**