

GATE-2000

CIVIL ENGINEERING

Duration : Three hours

Maximum marks : 150

SECTION A. (75 Marks)

1. This question consists of 27 (Twenty Seven) multiple-choice type sub-questions each carrying one mark. The answers to the multiple choice questions MUST be written only in the boxes corresponding to the question number by writing A, B, C or D in the answer book. (27 × 1=27)

1.1. If, A, B, C are square matrices of the same order, $(ABC)^{-1}$ is equal to

- (a) $C^{-1} A^{-1} B^{-1}$ (b) $C^{-1} B^{-1} A^{-1}$
 (c) $A^{-1} B^{-1} C^{-1}$ (d) $A^{-1} C^{-1} B^{-1}$

1.2. The following integral $\lim_{a \rightarrow \infty} \int_1^a x^{-3} dx$

- (a) Diverges (b) Converges to $\frac{1}{3}$
 (c) Converges to $-\frac{1}{a^3}$ (d) Converges to 0

1.3. A function with a period 2π is shown below

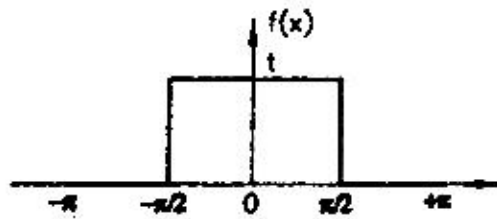

The Fourier series for this function is given by

- (a) $f(x) = \frac{1}{2} + \sum_{n=1}^{\infty} \frac{2}{n\pi} \sin \frac{n\pi}{2}$
 (b) $f(x) = \sum_{n=1}^{\infty} \frac{2}{n\pi} \sin \frac{n\pi}{2} \cos nx$
 (c) $f(x) = \frac{1}{2} + \sum_{n=1}^{\infty} \frac{2}{n\pi} \sin \frac{n\pi}{2}$
 (d) $f(x) = \sum_{n=1}^{\infty} \frac{2}{n\pi} \sin \frac{n\pi}{2} \sin nx$

1.4. Consider the following two statements :

- I. The maximum number of linearly independent column vectors of a matrix A is called the rank of A.
 II. If A is an $n \times n$ square matrix, it will be nonsingular if rank A = n.

With reference to the above statements, which of the following applies ?

- (a) Both the statements are false
 (b) Both the statements are true.
 (c) I is true but II is false.
 (d) I is false but II is true.

1.5. The dimensions for the flexural rigidity of a beam element in mass (M), length (L) and time (T) is given by

- (a) MT^{-2} (b) $ML^3 T^{-2}$
 (c) $ML^{-1} T^{-2}$ (d) $ML^{-1} T^2$

1.6. A two span beam with an internal hinge is shown below.

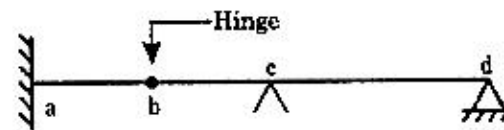

Conjugate beam corresponding to this beam is

- (a)
- (b)
- (c)
- (d)

1.7. Pick the incorrect statement from the following four statements :

- (a) On the plane which carries maximum normal stress, the shear stress is zero.
 (b) Principal planes are mutually orthogonal.
 (c) On the plane which carries maximum shear stress, the normal stress is zero.
 (d) The principal stress axes and principal strain axes coincide for an isotropic material.



- 1.16. If duty (D) is 1428 hectares/cumec and base period (B) is 120 days for an irrigated crop, then delta (Δ) in meters is given by
 (a) 102.8 (b) 0.73
 (c) 1.38 (d) 0.01
- 1.17. The relation that must hold for the flow to be irrotational is
 (a) $\frac{\partial u}{\partial y} - \frac{\partial v}{\partial x} = 0$ (b) $\frac{\partial u}{\partial x} = \frac{\partial v}{\partial y}$
 (c) $\frac{\partial^2 u}{\partial x^2} + \frac{\partial^2 v}{\partial y^2} = 0$ (d) $\frac{\partial u}{\partial y} = -\frac{\partial v}{\partial x}$
- 1.18. Cavitation is caused by
 (a) high velocity (b) low pressure
 (c) high pressure (d) high temperature
- 1.19. If the pump head is 75m, discharge is $0.464 \text{ m}^3/\text{s}$ and the motor speed is 1440 rpm at rated condition, the specific-speed of the pump is about
 (a) 4 (b) 26
 (c) 38 (d) 1440
- 1.20. The BOD removal efficiency, in percentage, during primary treatment, under normal conditions is about
 (a) 65% (b) 85%
 (c) 30% (d) Zero
- 1.21. Critical factors for the activated sludge treatment process are
 (a) maximum hourly flow rate.
 (b) maximum and minimum flow rate.
 (c) maximum hourly flow rate and maximum daily organic load.
 (d) minimum hourly flow rate and minimum daily organic load.
- 1.22. Use of coagulants such as alum
 (a) results in reduction of pH of the treated water.
 (b) results in increase of pH of the treated water.
 (c) results in no change in pH of the treated water.
 (d) may cause and increase or decrease of pH of the treated water.
- 1.23. The disinfection efficiency of chlorine in water treatment
 (a) is not dependent on pH value.
 (b) is increase by increased pH value.
 (c) remains constant at all pH value.
 (d) is reduced by increased pH value.
- 1.24. The standard plate size in a plate bearing test for finding modulus of subgrade reaction (k) value is
 (a) 100 cm diameter (b) 50 cm diameter
 (c) 75 cm diameter (d) 25 cm diameter
- 1.25. Width of carriage way for a single lane is recommended to be
 (a) 7.5 m (b) 7.0 m
 (c) 3.75 m (d) 5.5 m
- 1.26. Stopping sight distance is the minimum distance available on a highway which is the
 (a) distance of sufficient length to stop the vehicle without collision.
 (b) distance visible to a driver during night driving
 (c) height of the object above the road surface.
 (d) distance equal to the height of the driver's eye above the road surface.
- 1.27. Bituminous materials are commonly use in highway construction because of their good
 (a) tensile and compression properties.
 (b) binding and water proofing properties.
 (c) shear strength and tensile properties.
 (d) bond and tensile properties.
2. This question consists of 24 (Twenty Four) multiple-choice type sub-questions, each carrying TWO marks. (24 × 2 = 48)
- 2.1 If $f(x, y, z) = (x^2 + y^2 + z^2)^{-\frac{1}{2}}$
 $\frac{\partial^2 f}{\partial x^2} + \frac{\partial^2 f}{\partial y^2} + \frac{\partial^2 f}{\partial z^2}$ is equal to
 (a) Zero (b) 1
 (c) 2 (d) $-3(x^2 + y^2 + z^2)^{-\frac{3}{2}}$
- 2.2. The Taylor expansion of $\sin x$ about $x = \pi/6$ is given by
 (a) $\frac{1}{2} + \frac{\sqrt{3}}{2}\left(x - \frac{\pi}{6}\right) - \frac{1}{4}\left(x - \frac{\pi}{6}\right)^2 - \frac{\sqrt{3}}{12}\left(x - \frac{\pi}{6}\right)^3 + \dots$
 (b) $x - \frac{x^3}{3!} + \frac{x^5}{5!} - \frac{x^7}{7!} + \dots$
 (c) $\left(x - \frac{\pi}{6}\right) - \frac{\left(x - \frac{\pi}{6}\right)^3}{3!} + \frac{\left(x - \frac{\pi}{6}\right)^5}{5!} - \frac{\left(x - \frac{\pi}{6}\right)^7}{7!} + \dots$
 (d) $\frac{1}{2}$



2.3. Let $F(s) = \mathcal{L}\{f(t)\}$ denote the Laplace transform of the function $f(t)$. Which of the following statements is correct?

(a) $\mathcal{L}\left[\frac{df}{dt}\right] = \frac{1}{s}F(s); \quad \mathcal{L}\int_0^t f(\tau)d\tau = sF(s) - f(0)$

(b) $\mathcal{L}\left[\frac{df}{dt}\right] = sF(s) - F(0); \quad \mathcal{L}\int_0^t f(\tau)d\tau = -\frac{dF}{ds}$

(c) $\mathcal{L}\left[\frac{df}{dt}\right] = sF(s) - F(0); \quad \mathcal{L}\int_0^t f(\tau)d\tau = F(s-a)$

(d) $\mathcal{L}\left[\frac{df}{dt}\right] = sF(s) - F(0); \quad \mathcal{L}\int_0^t f(\tau)d\tau = \frac{1}{s}F(s)$

2.4. The limit of the function $f(x) = [1 - a^4/x^4]$ as $x \rightarrow \infty$ is given by

- (a) 1 (b) $\exp[-a^4]$
 (c) ∞ (d) Zero

2.5. The maxima and minima of the function $f(x) = 2x^3 - 15x^2 + 36x + 10$ occur, respectively, at

- (a) $x = 3$ and $x = 2$ (b) $x = 1$ and $x = 3$
 (c) $x = 2$ and $x = 3$ (d) $x = 3$ and $x = 4$

2.6. The four cross sections shown below are required to be ordered in the increasing order of their respective shape factors.

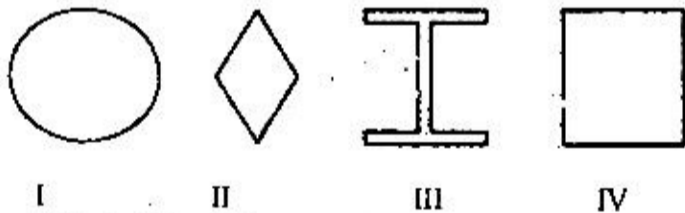

Which of the following order is correct?

- (a) III, I, IV, II (b) I, II, III, IV
 (c) III, IV, I, II (d) III, IV, II, I

2.7. A simply supported beam with an overhang is traversed by a unit concentrated moment from the left to the right as shown below:

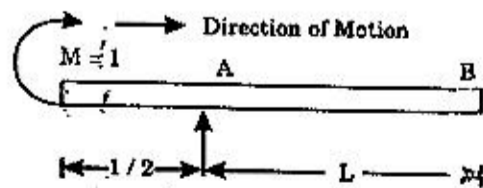

The influence line for reaction at B is given by

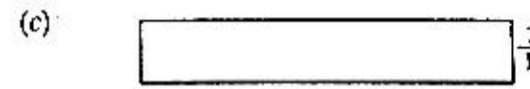
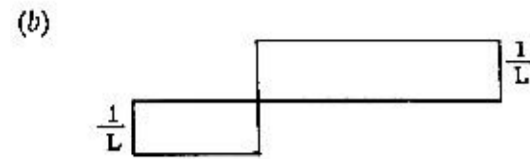

(d) zero everywhere

2.8. The following two statements are made with reference to the planar truss shown below:

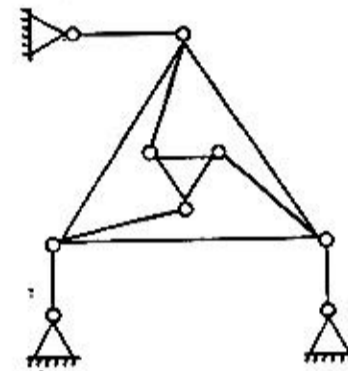

- I. The truss is statically determinate
 II. The truss is kinematically determinate

With reference to the above statements, which of the following applies?

- (a) Both statements are true.
 (b) Both statements are false.
 (c) II is true but I false.
 (d) I is true but II is false.

2.9. A cantilever beam of length L and a cross section with shape factor f supports a concentrated load P as shown below:

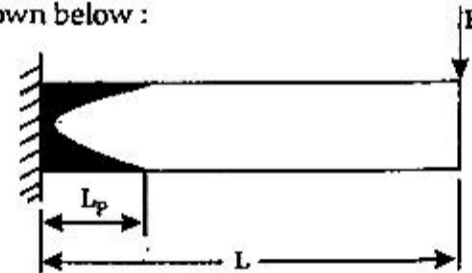

The length L_p of the plastic zone, when the maximum bending moment, equals the plastic moment M_p , given by

- (a) $\frac{L_p}{L} = \frac{1}{f}$ (b) $\frac{L_p}{L} = L(1-f)$
 (c) $\frac{L_p}{L} = 1 - \frac{1}{\sqrt{f}}$ (d) $\frac{L_p}{L} = 1 - \frac{1}{f}$



2.10. For the structure shown below, the vertical deflection at point A is given by

- (a) $\frac{PL^3}{81EI}$
 (b) $\frac{2PL^3}{81EI}$
 (c) Zero
 (d) $\frac{PL^3}{72EI}$

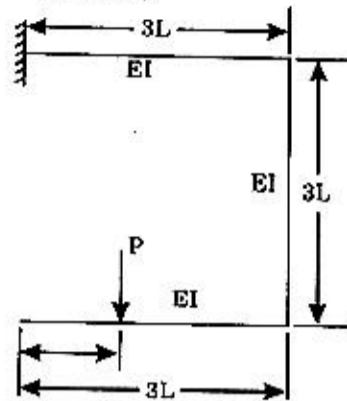

2.11. The ultimate bearing capacity of a soil is 300 kN/m^2 . The depth of foundation is 1 m and unit weight of soil is 20 kN/m^3 . Choosing a factor of safety of 2.5, the net safe bearing capacity is

- (a) 100 kN/m^2 (b) 112 kN/m^2
 (c) 80 kN/m^2 (d) 100.5 kN/m^2

2.12. A deep cut of 7 m has to be made in a clay with unit weight 16 kN/m^3 and a cohesion of 25 kN/m^2 . What will be the factor of safety if one has to have a slope angle of 30° ? Stability number is given to be 0.178 (from Taylor's chart) for a depth factor of 3.

- (a) 0.80 (b) 1.1
 (c) 1.25 (d) 1.0

2.13. In a drained triaxial compression test, a saturated specimen of a cohesionless sand fails under a deviatoric stress of 3 kgf/cm^2 when the cell pressure is 1 kgf/cm^2 . The effective angle of shearing resistance of sand is about

- (a) 37° (b) 45°
 (c) 53° (d) 20°

2.14. Two footings, one circular and the other square, and founded on the surface of a purely cohesionless soil. The diameter of the circular footing is same as that of the side of the square footing. The ratio of their ultimate bearing capacities is

- (a) $3/4$ (b) $4/3$
 (c) 1.0 (d) 1.3

2.15. To have zero active pressure intensity at the tip of a wall in cohesive soil, one should apply a uniform surcharge intensity of

- (a) $2c \tan \alpha$ (b) $2c \cot \alpha$
 (c) $-2c \tan \alpha$ (d) $-2c \cot \alpha$

2.16. Water flows at a depth of 0.1 m with a velocity of 6 m/s in a rectangular channel. The alternate depth is

- (a) 0.30 m (b) 0.40 m
 (c) 0.86 m (d) 0.81 m

2.17. In an area of 200 hectare, water table drops by 4 m . If the porosity is 0.35 and the specific retention is 0.15, change in volume of storage in the aquifer is

- (a) 160 m^3 (b) $1.6 \times 10^6 \text{ m}^3$
 (c) $8 \times 10^6 \text{ m}^3$ (d) $1.6 \times 10^3 \text{ m}^3$

2.18. A tube well having a capacity of $4 \text{ m}^3/\text{hour}$ operates for 20 hours each day during the irrigation season. How much area can be commanded if the irrigation interval is 20 days and depth of irrigation is 7 cm ?

- (a) $1.71 \times 10^4 \text{ m}^2$ (b) $1.14 \times 10^4 \text{ m}^2$
 (c) $22.9 \times 10^4 \text{ m}^2$ (d) $2.29 \times 10^4 \text{ m}^2$

2.19. The parameters in Horton's infiltration equation $[f(t) = f_c + (f_o - f_c)e^{-kt}]$ are given as, $f_o = 7.62 \text{ cm/hour}$, $f_c = 1.34 \text{ cm/hour}$ and $k = 4.182/\text{hour}$. For assumed continuous ponding the cumulative infiltration at the end of 2 hours is

- (a) 2.68 cm (b) 1.50 cm
 (c) 1.34 cm (d) 4.18 cm

2.20. Water flows at a rate of $10 \text{ m}^3/\text{s}$ in a rectangular channel 3 m wide. The critical depth of flow is

- (a) 1.13 m (b) 2 m
 (c) 1.45 m (d) 1.04 m

2.21. A circular sewer 2 m diameter has to carry a discharge of $2 \text{ m}^3/\text{s}$ when flowing nearly full. What is the minimum required slope to initiate the flow? Assume Manning's $n = 0.015$.

- (a) 0.00023 (b) 0.000036
 (c) 0.000091 (d) 0.000014

2.22. The following characteristics pertain to the sand filters used in water industry.

- I. Filtration rate is $1 \text{ to } 4 \text{ m}^3/(\text{m}^2 \text{ day})$.
- II. Typical duration of operation in one run is 24 to 72 hours.
- III. Operating cost is low.

Which of the above characteristics pertain to slow sand filters?

- (a) I, II and III (b) I and II
 (c) II and III (d) I and III

2.23. The ruling minimum radius of horizontal curve of a national highway in plain terrain for a ruling design speed of 100 km/hour with $e = 0.07$ and $f = 0.15$ is close to

- (a) 250 m (b) 360 m
 (c) 36 m (d) 300 m

2.24. Design rate of super elevation for horizontal highway curve of radius 450 m for a mixed traffic condition, having a speed of 125 km/hour is

- (a) 1.0 (b) 0.05
 (c) 0.07 (d) 0.154



SECTION B. (75 Marks)

This section consists of TWENTY questions of FIVE marks each. ANY FIFTEEN out of them have to be answered. Answers to each questions must be started on a fresh page. If more number of questions are attempted, score off the answers not to be evaluated, else only the first fifteen unscored answer will be considered strictly. (15 × 5 = 75)

3. Find the solution of the differential equation

$$\frac{d^2y}{dt^2} + \lambda^2y = \cos \omega t + k \text{ with initial conditions}$$

$y(0) = 0, \frac{dy}{dt}(0) = 0$. Here λ, ω and k are constants. Use either the method of undetermined coefficients

or the operator $\left(D = \frac{d}{dt}\right)$ based method.

4. A is a square matrix is given by

$$A = \begin{bmatrix} 2 & 0 \\ -1 & 2 \\ 0 & -1 & 2 \end{bmatrix}$$

One of the eigenvalues of A is given to be equal to 2. Determine the other eigenvalues. Express the eigenvector corresponding to the lowest eigenvalue in the form $[1 \ a \ b]^T$ and determine a and b.

5. A cantilever beam AB carries a concentrated force P and a moment $M = PL/3$ at its tip as shown below. Show using Castigliano's theorem that, if the angle of inclination α of the line of action of the force P is such that $\sin \alpha = 1/2$, then the displacement of the point B, due to bending will be in the direction of force P.

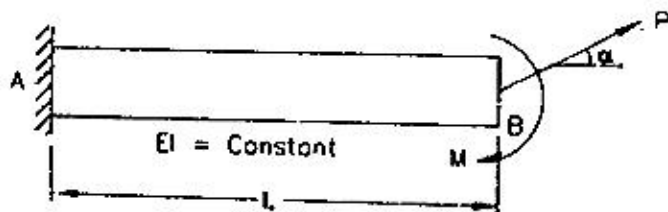

6. A beam AB is suspended from a wire CB as shown in figure below. The beam carries a central concentrated load P. It may be assumed that $E = 7 \times 10^{10} \text{ N/m}^2, I = 800 \text{ mm}^4, A = 1.2 \text{ mm}^2$, and $P = 300 \text{ N}$. Determine, using stiffness matrix approach, the deflection of point B. What would be this deflection if the load P were to be applied upwards, instead of downwards? The axial deformation of the beam AB may be ignored.

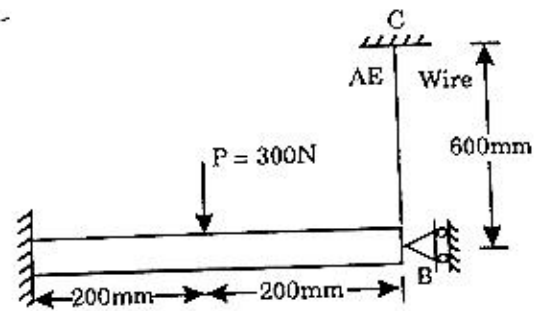

The stiffness matrix for a beam element is given to be as follows.

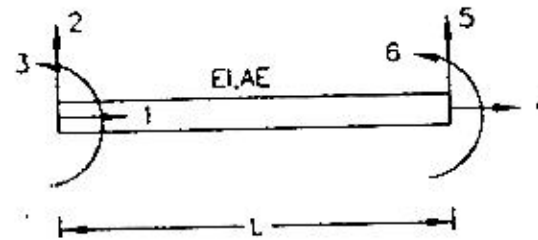

$$K = \frac{EL}{L^3} \begin{bmatrix} \frac{AL^2}{I} & & & & & \\ & \text{Symmetric} & & & & \\ & & 0 & 12 & & \\ & & 0 & 6L & 4L^2 & \\ -\frac{AL^2}{I} & & 0 & 0 & \frac{AL^2}{I} & \\ & & 0 & -12 & -6L & 0 & 12 & \vdots \\ & & 0 & 6L & -2L^2 & 0 & -6L & 4L^2 \end{bmatrix}$$

7. A simply supported rectangular prestressed concrete beam 200 mm wide and 400 mm deep has an effective span of 12 m. The prestressing cable has a triangular profile with zero eccentricity at ends and 70 mm at the midspan as shown in the figure below. The effective prestress is 800 kN after all losses. Determine the value of a point load, the beam can support at the midspan if the pressure line passes through the upper kern of the section. The weight density of the material of the beam can be taken to be 25 kN/m^3 .

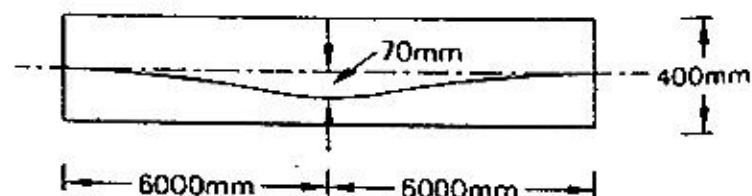

8. A two hinged parabolic arch carries two concentrated moments as shown in the figure below. The moment of inertia of the arch at any particular cross section is equal to the moment of inertia at the crown multiplied by the secant of the angle θ , where θ is the angle between the horizontal and the tangent to the arch axis at that particular section. Determine the support reactions.

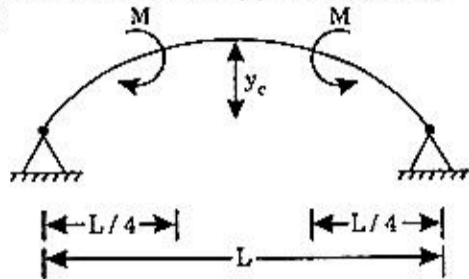

9. A continuous beam $250 \text{ mm} \times 450 \text{ mm}$ carries 6 numbers of 12 mm diameter longitudinal bars as shown. The factored shear force at the point of inflection is 200 kN . Check if the beam is safe in bond. Assume M15 mix with $\sigma_{s,ck} = 15 \text{ N/mm}^2$ and mild steel with $\sigma_y = 250 \text{ N/mm}^2$. A clear cover of 25 mm can be assumed. The design bond stress for mild steel bars in M15 concrete is specified to be 1.0 N/mm^2 .

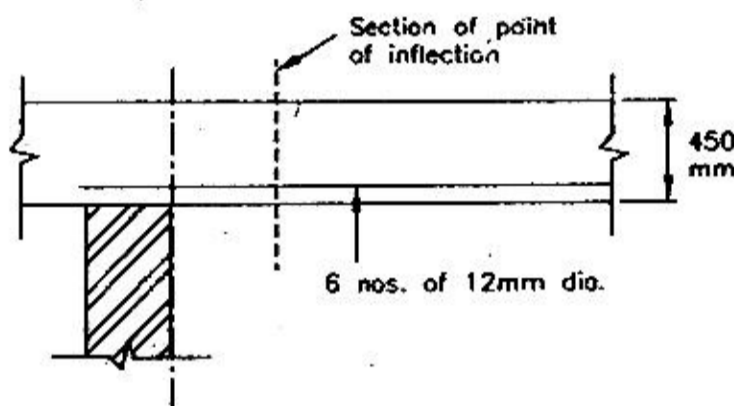

10. A 12 mm bracket plate is connected to a column flange as shown in the figure below. The bracket transmits a load of $W = 200 \text{ kN}$ to the column flange. A 10 mm fillet weld is provided along AB, BC and CD. If $e = 350 \text{ mm}$, $b = 200 \text{ mm}$ and $d = 650 \text{ mm}$, verify if the size of the weld provided is adequate. Allowable shearing stress in the fillet weld can be taken to be 108 MPa .

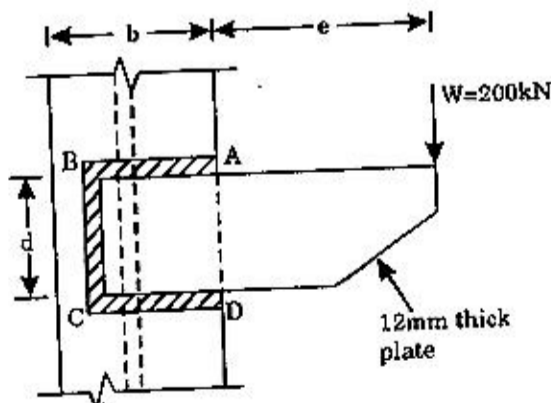

11. A 5 m thick clay layer lies between two layers of sand each 4 m thick, the top of the upper layer of sand being at ground level. The water table is 2 m below the piezometric surface being 4 m above ground level. The saturated unit weight of clay is 20 kN/m^3 and that of sand is 19 kN/m^3 . Above the water table unit weight of sand is 16.5 kN/m^3 . Calculate the effective vertical stresses at the top and bottom of the layer. Also draw the total vertical stress diagram in the given soil layers.

12. In an oedometer test, a specimen of saturated clay 19 mm thick reaches 50% consolidation in 20 minutes. How long it would take a layer of this clay 5 m thick to reach the same degree of consolidation under the same stress and drainage conditions? How long would it take for the clay layer to reach 30% consolidation?

13. A footing 3 m square carries a gross pressure of 350 kN/m^2 at a depth of 1.2 m in sand. The saturated unit weight of sand is 20 kN/m^3 and the unit weight above the water table is 17 kN/m^3 . The shear strength parameters are $c' = 0$ and $\phi' = 30^\circ$. (For $\phi' = 30^\circ$, $N_q = 22$ and $N_\gamma = 20$). Determine the factor of safety with respect of shear failure for the following cases:

- (a) water table is 5 m below ground level.
(b) water table is at 1.2 m below ground level.

14. For the retaining wall shown in the figure below assume that the wall can yield sufficiently to develop active stage. Use Rankine's active earth pressure theory and determine (a) active force per meter of the wall, and (b) the location of the resultant line of action.

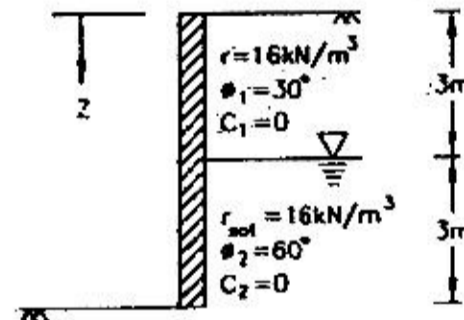

15. A pump is to deliver water at a rate of $1.4 \text{ m}^3/\text{s}$ from a sump to a reservoir which is 10 km away through a steel pipe 1200 mm in diameter for a length of 5 km and the remaining through a PSC pipe of diameter 1000 mm . The elevation difference between the full tank level of the delivery reservoir and the low water level of the sump is 50 m . What is the Break Horse Power (in kW) requirement of the motor? Assume a pump house loss of 3.75 m and minor losses to be 10% of the friction losses. Use Darcy-Weisbach friction factor (f) of 0.018 for steel pipe and 0.02 for PSC pipe with a pump efficiency of 80% .



16. A 1 : 49 scale model of a proposed dam is used to predict prototype flow conditions. The design flood discharge near the spillway is 15000 m³/s. Establish the relation between velocities in the model and prototype. What flow rate should be established in the model to simulate this flow ? If a velocity of 1.2 m/s is measured at a point in the model what is the velocity at a corresponding point in the prototype ?
17. An area of 1 hectare is irrigated through a stream of 0.03 m³/s. Depth of the root zone is 1 m and available moisture holding capacity is 16 cm/m. Irrigation water is supplied when 50% of the available moisture is depleted. Water application efficiency is 60% Determine the storage efficiency.
18. A 6 hour unit hydrograph of a watershed is given below. Calculate 18 hour unit hydrograph using S- curve method and tabulate the results.

Time(hour)	6hr unit hydrograph [m ³ /(cm)]
0	0
6	1.8
12	30.9
18	85.6
24	41.8
30	14.6
36	5.5
42	1.8

19. Consider a glucose solution (C₆H₁₂O₆) of molarity 1.75×10^{-3} that is completely oxidized to CO₂ and H₂O. Find the amount of oxygen required for this reaction. The chemical mass balance equation for the above reaction is given as

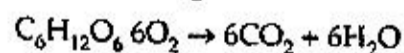

(Atomic weights are : C = 12; H = 1; O = 16).

20. The dissolved oxygen (DO) in an unseeded sample of diluted waste having an initial DO of 9.5 mg/l is measured to be 3.5 mg/l after 5 days. The dilution factor is 0.03 and the reaction rate constant, $k = 0.22/\text{day}$ (to the base 'e' in the decay curve at 20°C.) Estimate

- (a) The 5 day BOD of the waste at 20° C.
 (b) Ultimate carbonaceous BOD.
 (c) Remaining oxygen demand after 5 days.
 (d) The 5 day BOD of this waste at 25° C assuming a temperature coefficient of 1.047.
21. The load penetration data from a California Bearing Ratio (CBR) test is provided in the following table. Indicate whether any correction is required for the calculated CBR value. Find the CBR value of the soil from the data provided.

Table : Load penetration data

Penetration(in mm)	Load in kgf (kg force)
0	0
0.5	4
1.0	13
1.5	29
2.0	40
2.5	50
3.0	58
4.0	70
5.0	78
7.5	93
10	103
12.5	112

Area of plunger is given as 19.6 cm². Pressure for standard crushed stones at 2.5 mm and 5.0 mm are 70 kgf/cm² and 105 kgf/cm² respectively.

22. An ascending gradient of 1 in 45 meets a descending gradient of 1 in 60. A summit curve has to be designed for design speed of 80 km/h so as to provide a safe overtaking sight distance of 230 m. Estimate the length of the summit curve.

