

AIEEE-2010

IMPORTANT INSTRUCTIONS

1. Immediately fill in the particulars on this page of the Test Booklet with Blue/Black Ball Point Pen. Use of Pencil is strictly prohibited.
2. The Answer Sheet is kept inside the Test Booklet. When you are directed to open the Test Booklet, take out the Answer Sheet and fill in the particulars carefully.
3. The test is of **3 hours** duration.
4. The Test Booklet consists of **90** questions. The maximum marks are **432**.
5. There are **three** parts in the question paper. The distribution of marks subject wise in each part is as under for each correct response.
Part A - Chemistry (144 marks) - Questions No. 4 to 9 and 13 to 30 consist of **FOUR (4)** marks each and Questions No. 1 to 3 and 10 to 12 consist of **EIGHT (8)** marks each for each correct response.
Part B - Physics (144 marks) - Questions No. 33 to 49 and 54 to 60 consist of **FOUR (4)** marks each and Questions No. 31 to 32 and 50 to 53 consist of **EIGHT (8)** marks each for each correct response.
Part C - Mathematics (144 marks) - Questions No. 61 to 69, 73 to 81 and 85 to 90 consist of **FOUR (4)** marks each and Questions No. 70 to 72 and 82 to 84 consist of **EIGHT (8)** marks each for each correct response.
6. Candidates will be awarded marks as stated above in Instruction No. 5 for correct response of each question. $\frac{1}{4}$ (one fourth) marks will be deducted for indicating incorrect response of each question. No **deduction** from the total score will be made **if no response** is indicated for an item in the Answer Sheet.
7. Use **Blue/Black Ball Point Pen only** for writing particulars/markings responses on **Side-1** and **Side-2** of the Answer Sheet. **Use of pencil is strictly prohibited.**
8. No candidate is allowed to carry any textual material, printed or written, bits of papers, pager, mobile phone, any electronic device, etc., except the Admit Card inside the examination hall/room.
9. Rough work is to be done on the space provided for this purpose in the Test Booklet only. This space is given at the bottom of each page and in 4 pages (Pages 20 - 23) at the end of the booklet.
10. On completion of the test, the candidate must hand over the Answer Sheet to the Invigilator on duty in the Room/Hall. **However, the candidates are allowed to take away this Test Booklet with them.**
11. The CODE for this Booklet is **D**. Make sure that the CODE printed on **Side-2** of the Answer Sheet is the same as that on this booklet. In case of discrepancy, the candidate should immediately report the matter to the Invigilator for replacement of both the Test Booklet and the Answer Sheet.
12. **Do not fold or make any stray marks on the Answer Sheet.**

PART A: CHEMISTRY

1. The standard enthalpy of formation of NH_3 is $-46.0 \text{ kJ mol}^{-1}$. If the enthalpy of formation of H_2 from its atoms is -436 kJ mol^{-1} and that of N_2 is -712 kJ mol^{-1} , the average bond enthalpy of N-H bond in NH_3 is

(1) -964 kJ mol^{-1} (2) $+352 \text{ kJ mol}^{-1}$ (3) $+1056 \text{ kJ mol}^{-1}$ (4) $-1102 \text{ kJ mol}^{-1}$

1. (2)

Sol : Enthalpy of formation of $\text{NH}_3 = -46 \text{ kJ/mole}$



Bond breaking is endothermic and Bond formation is exothermic

Assuming 'x' is the bond energy of N-H bond (kJ mol^{-1})

$$\therefore 712 + (3 \times 436) - 6x = -46 \times 2$$

$$\therefore x = 352 \text{ kJ/mol}$$

2. The time for half life period of a certain reaction $\text{A} \rightarrow \text{products}$ is 1 hour. When the initial concentration of the reactant 'A', is 2.0 mol L^{-1} , how much time does it take for its concentration to come from 0.50 to 0.25 mol L^{-1} if it is a zero order reaction ?

(1) 4 h (2) 0.5 h (3) 0.25 h (4) 1 h

2. (3)

Sol : For a zero order reaction $k = \frac{x}{t} \rightarrow (1)$

Where $x = \text{amount decomposed}$

$k = \text{zero order rate constant}$

for a zero order reaction

$$k = \frac{[A]_0}{2t_{\frac{1}{2}}} \rightarrow (2)$$

Since $[A_0] = 2\text{M}$, $t_{1/2} = 1 \text{ hr}$; $k = 1$

\therefore from equation (1)

$$t = \frac{0.25}{1} = 0.25 \text{ hr}$$

3. A solution containing 2.675 g of $\text{CoCl}_3 \cdot 6\text{NH}_3$ (molar mass = 267.5 g mol^{-1}) is passed through a cation exchanger. The chloride ions obtained in solution were treated with excess of AgNO_3 to give 4.78 g of AgCl (molar mass = 143.5 g mol^{-1}). The formula of the complex is (At. Mass of $\text{Ag} = 108 \text{ u}$)

(1) $[\text{Co}(\text{NH}_3)_6]\text{Cl}_3$ (2) $[\text{CoCl}_2(\text{NH}_3)_4]\text{Cl}$ (3) $[\text{CoCl}_3(\text{NH}_3)_3]$ (4) $[\text{CoCl}(\text{NH}_3)_5]\text{Cl}_2$

3. (1)

Sol : $\text{CoCl}_3 \cdot 6\text{NH}_3 \rightarrow x\text{Cl}^- \xrightarrow{\text{AgNO}_3} x \text{AgCl} \downarrow$

$$n(\text{AgCl}) = x n(\text{CoCl}_3 \cdot 6\text{NH}_3)$$

$$\frac{4.78}{143.5} = x \frac{2.675}{267.5} \quad \therefore x = 3$$

\therefore The complex is $[\text{Co}(\text{NH}_3)_6]\text{Cl}_3$

4. Consider the reaction :

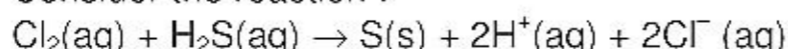

The rate equation for this reaction is $\text{rate} = k [\text{Cl}_2] [\text{H}_2\text{S}]$

Which of these mechanisms is/are consistent with this rate equation ?

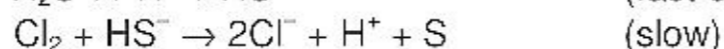
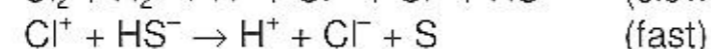
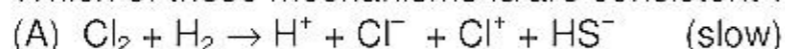

(1) B only (2) Both A and B (3) Neither A nor B (4) A only

4. (4)

Sol: Rate equation is to be derived wrt slow

Step \therefore from mechanism (A)

$$\text{Rate} = k[\text{Cl}_2][\text{H}_2\text{S}]$$

5. If 10^{-4} dm^3 of water is introduced into a 1.0 dm^3 flask to 300 K, how many moles of water are in the vapour phase when equilibrium is established ?

(Given : Vapour pressure of H_2O at 300 K is 3170 Pa ; $R = 8.314 \text{ J K}^{-1} \text{ mol}^{-1}$)

(1) $5.56 \times 10^{-3} \text{ mol}$ (2) $1.53 \times 10^{-2} \text{ mol}$ (3) $4.46 \times 10^{-2} \text{ mol}$ (4) $1.27 \times 10^{-3} \text{ mol}$

5. (4)

Sol : $n = \frac{PV}{RT} =$

$$= 128 \times 10^{-5} \text{ moles}$$

$$= \frac{3170 \times 10^{-5} \text{ atm} \times 1 \text{ L}}{0.0821 \text{ L atm K}^{-1} \text{ mol}^{-1} \times 300 \text{ K}} \approx 1.27 \times 10^{-3} \text{ mol}$$

6. One mole of a symmetrical alkene on ozonolysis gives two moles of an aldehyde having a molecular mass of 44 u. The alkene is

(1) propene (2) 1-butene (3) 2-butene (4) ethene

6. (3)

Sol : 2-butene is symmetrical alkene

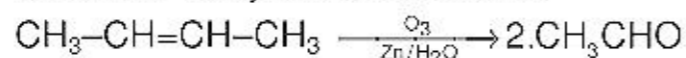

Molar mass of CH_3CHO is 44 u.

7. If sodium sulphate is considered to be completely dissociated into cations and anions in aqueous solution, the change in freezing point of water (ΔT_f), when 0.01 mol of sodium sulphate is dissolved in 1 kg of water, is ($K_f = 1.86 \text{ K kg mol}^{-1}$)

(1) 0.0372 K (2) 0.0558 K (3) 0.0744 K (4) 0.0186 K

7. (2)

Sol : Vant Hoff's factor (i) for $\text{Na}_2\text{SO}_4 = 3$

$$\therefore \Delta T_f = (i) k_f m$$

$$= 3 \times 1.86 \times \frac{0.01}{1} = 0.0558 \text{ K}$$

8. From amongst the following alcohols the one that would react fastest with conc. HCl and anhydrous ZnCl_2 , is

(1) 2-Butanol (2) 2-Methylpropan-2-ol (3) 2-Methylpropanol (4) 1-Butanol

8. (2)

Sol : 3° alcohols react fastest with $\text{ZnCl}_2/\text{conc. HCl}$ due to formation of 3° carbocation and

\therefore 2-methyl propan-2-ol is the only 3° alcohol

9. In the chemical reactions,

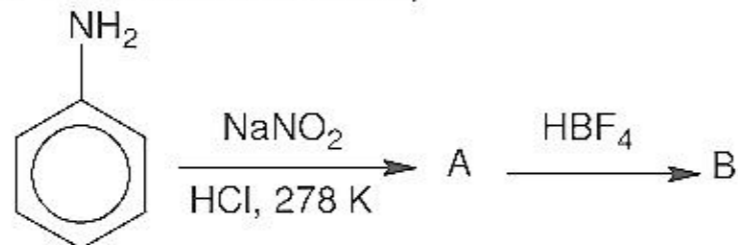

the compounds 'A' and 'B' respectively are

(1) nitrobenzene and fluorobenzene (2) phenol and benzene
(3) benzene diazonium chloride and fluorobenzene (4) nitrobenzene and chlorobenzene

9. (3)

Sol :

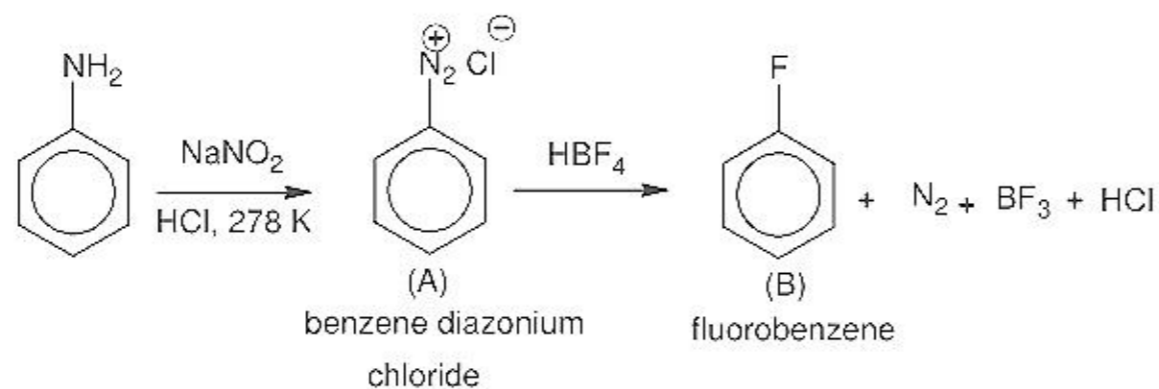

10. 29.5 mg of an organic compound containing nitrogen was digested according to Kjeldahl's method and the evolved ammonia was absorbed in 20 mL of 0.1 M HCl solution. The excess of the acid required 15 mL of 0.1 M NaOH solution for complete neutralization. The percentage of nitrogen in the compound is

(1) 59.0 (2) 47.4 (3) 23.7 (4) 29.5

10. (3)

Sol : Moles of HCl reacting with ammonia

$$= (\text{moles of HCl absorbed}) - (\text{moles of NaOH solution required})$$

$$= (20 \times 0.1 \times 10^{-3}) - (15 \times 0.1 \times 10^{-3})$$

$$= \text{moles of NH}_3 \text{ evolved.}$$

$$= \text{moles of nitrogen in organic compound}$$

$$\therefore \text{wt. of nitrogen in org. comp} = 0.5 \times 10^{-3} \times 14 = 7 \times 10^{-3} \text{ g}$$

$$\% \text{ wt} = \frac{7 \times 10^{-3}}{29.5 \times 10^{-3}} = 23.7\%$$

11. The energy required to break one mole of Cl-Cl bonds in Cl₂ is 242 kJ mol⁻¹. The longest wavelength of light capable of breaking a single Cl - Cl bond is

$$(c = 3 \times 10^8 \text{ ms}^{-1} \text{ and } N_A = 6.02 \times 10^{23} \text{ mol}^{-1})$$

(1) 594 nm (2) 640 nm (3) 700 nm (4) 494 nm

11. (4)

Sol : Energy required for 1 Cl₂ molecule = $\frac{242 \times 10^3}{N_A}$ Joules.

This energy is contained in photon of wavelength ' λ '.

$$\frac{hc}{\lambda} = E \Rightarrow \frac{6.626 \times 10^{-34} \times 3 \times 10^8}{\lambda} = \frac{242 \times 10^3}{6.022 \times 10^{23}}$$

$$\lambda = 4947 \text{ \AA} \approx 494 \text{ nm}$$

12. Ionisation energy of He⁺ is $19.6 \times 10^{-18} \text{ J atom}^{-1}$. The energy of the first stationary state ($n = 1$) of Li²⁺ is

(1) $4.41 \times 10^{-16} \text{ J atom}^{-1}$

(2) $-4.41 \times 10^{-17} \text{ J atom}^{-1}$

(3) $-2.2 \times 10^{-15} \text{ J atom}^{-1}$

(4) $8.82 \times 10^{-17} \text{ J atom}^{-1}$

12. (2)

Sol : $IE_{\text{He}^+} = 13.6 Z_{\text{He}^+}^2 \left[\frac{1}{1^2} - \frac{1}{\infty^2} \right] = 13.6 Z_{\text{He}^+}^2$ where ($Z_{\text{He}^+} = 2$)

$$\text{Hence } 13.6 \times Z_{\text{He}^+}^2 = 19.6 \times 10^{-18} \text{ J atom}^{-1}.$$

$$(E_1)_{\text{Li}^{2+}} = -13.6 Z_{\text{Li}^{2+}}^2 \times \frac{1}{1^2} = -13.6 Z_{\text{He}^+}^2 \times \left[\frac{Z_{\text{Li}^{2+}}^2}{Z_{\text{He}^+}^2} \right] = -19.6 \times 10^{-18} \times \frac{9}{4} = -4.41 \times 10^{-17} \text{ J/atom}$$

13. Consider the following bromides :

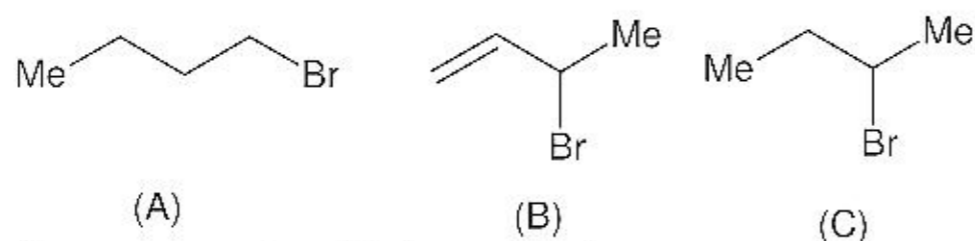

The correct order of S_N1 reactivity is

- (1) $B > C > A$ (2) $B > A > C$ (3) $C > B > A$ (4) $A > B > C$

13. (1)

Sol : S_N1 proceeds via carbocation intermediate, the most stable one forming the product faster. Hence reactivity order for A, B, C depends on stability of carbocation created.

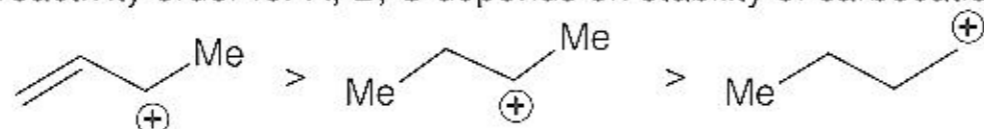

14. Which one of the following has an optical isomer ?

- (1) $[Zn(en)(NH_3)_2]^{2+}$ (2) $[Co(en)_3]^{3+}$ (3) $[Co(H_2O)_4(en)]^{3+}$ (4) $[Zn(en)_2]^{2+}$

(en = ethylenediamine)

14. (2)

Sol : Only option (2) is having non-super imposable mirror image & hence one optical isomer.

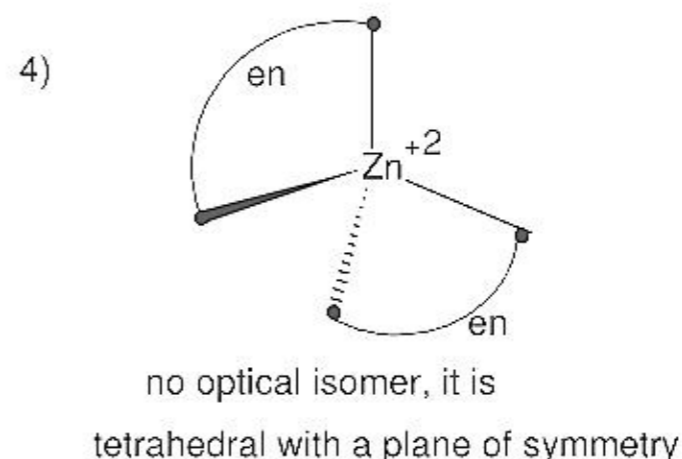
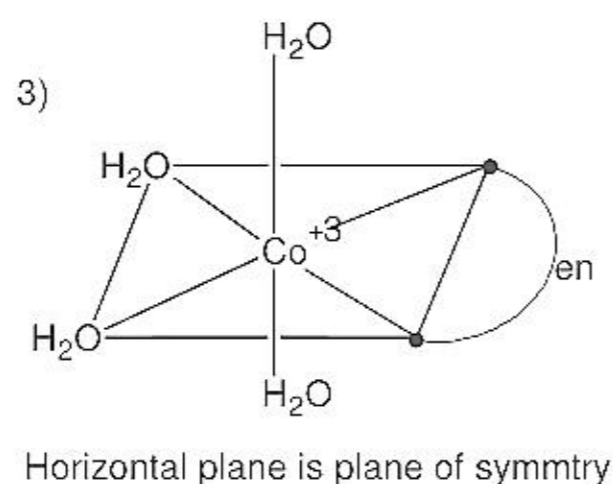
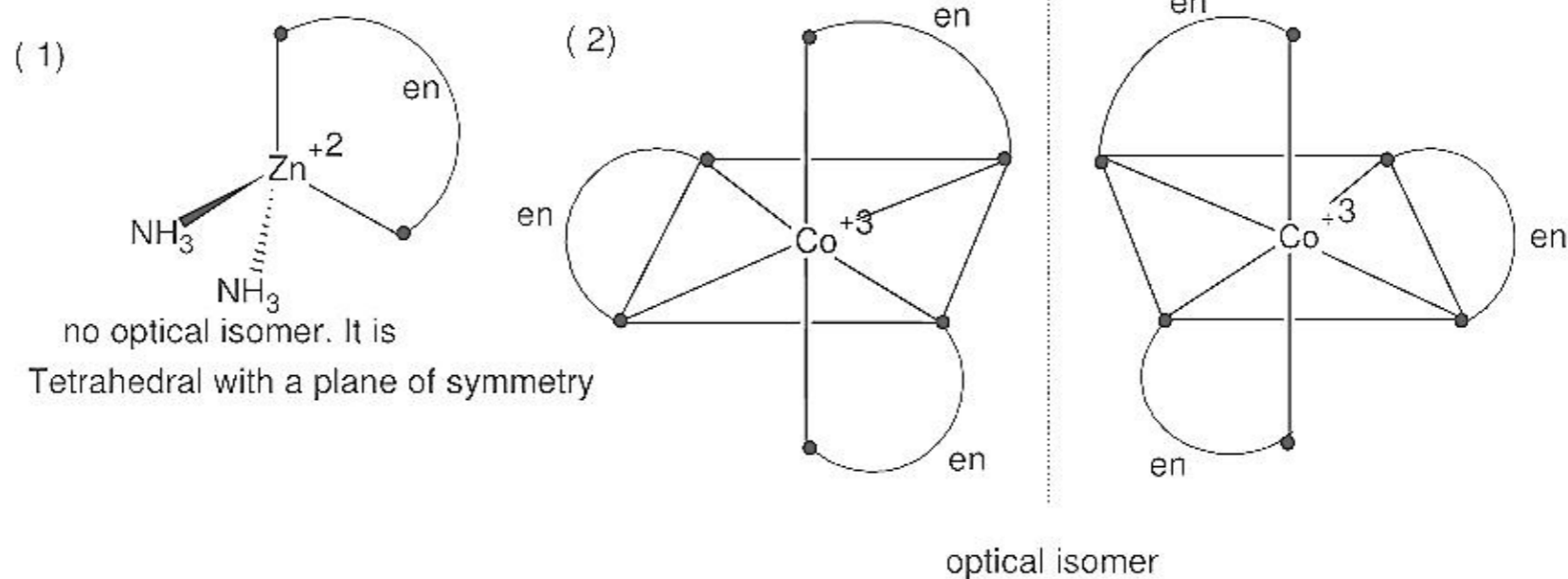

15. On mixing, heptane and octane form an ideal solution. At 373 K, the vapour pressures of the two liquid components (heptane and octane) are 105 kPa and 45 kPa respectively. Vapour pressure of the solution obtained by mixing 25.0g of heptane and 35 g of octane will be (molar mass of heptane = 100 g mol^{-1} and of octane = 114 g mol^{-1}).

- (1) 72.0 kPa (2) 36.1 kPa (3) 96.2 kPa (4) 144.5 kPa

15. (1)

Sol : Mole fraction of Heptane = $\frac{25/100}{\frac{25}{100} + \frac{35}{114}} = \frac{0.25}{0.557} = 0.45$

$$X_{\text{Heptane}} = 0.45$$

$$\therefore \text{Mole fraction of octane} = 0.55 = X_{\text{octane}}$$

$$\begin{aligned} \text{Total pressure} &= \sum X_i P_i^0 \\ &= (105 \times 0.45) + (45 \times 0.55) \text{ kPa} \\ &= 72.0 \text{ kPa} \end{aligned}$$

16. The main product of the following reaction is $\text{C}_6\text{H}_5\text{CH}_2\text{CH}(\text{OH})\text{CH}(\text{CH}_3)_2 \xrightarrow{\text{conc. H}_2\text{SO}_4} ?$

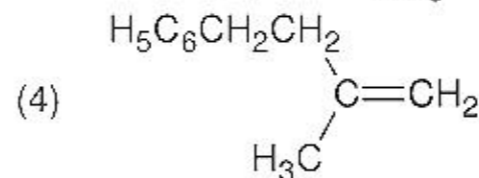
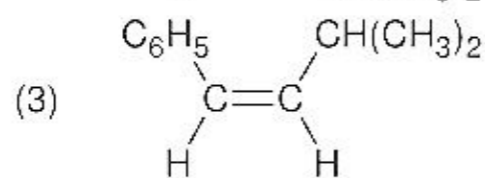
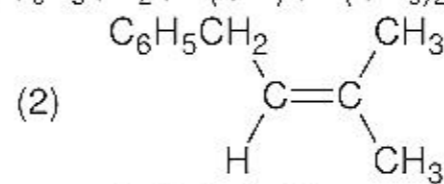
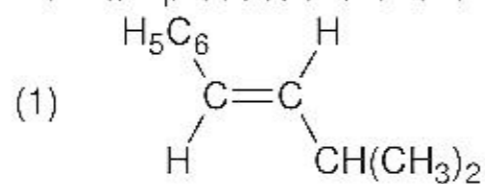

16. (1)
Sol :

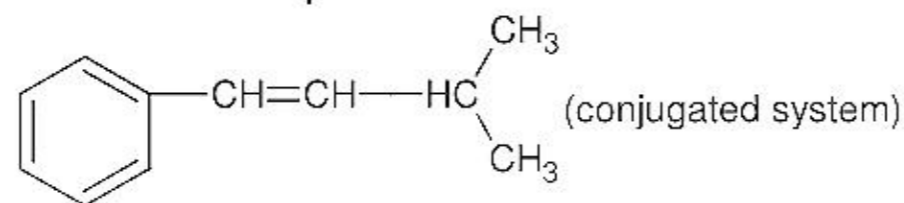
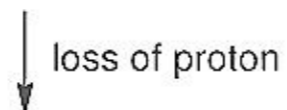
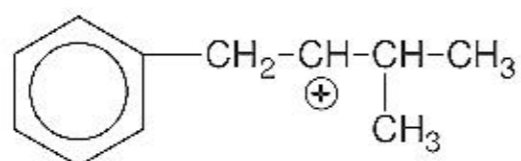
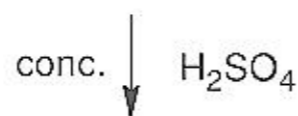
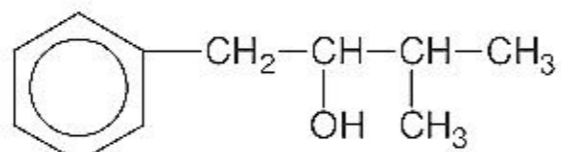

Trans isomer is more stable & main product here

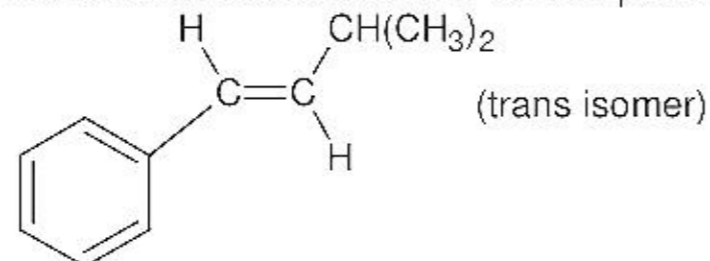

17. Three reactions involving H_2PO_4^- are given below :

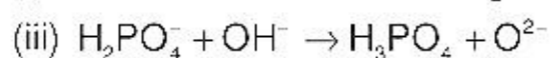
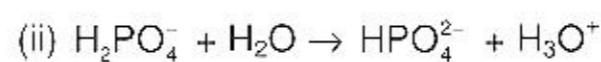
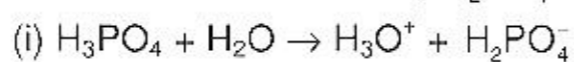

In which of the above does H_2PO_4^- act as an acid ?

17. (1) (ii) only (2) (i) and (ii) (3) (iii) only (4) (i) only
 (1)
 Sol : (i) $\text{H}_3\text{PO}_4 + \text{H}_2 \rightarrow \text{H}_3\text{O}^+ + \text{H}_2\text{PO}_4^-$
acid conjugate base

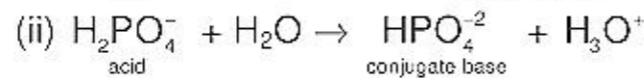

Only in reaction (ii) H_2PO_4^- acts as 'acid'.

18. In aqueous solution the ionization constants for carbonic acid are
 $K_1 = 4.2 \times 10^{-7}$ and $K_2 = 4.8 \times 10^{-11}$
 Select the correct statement for a saturated 0.034 M solution of the carbonic acid.
 (1) The concentration of CO_3^{2-} is 0.034 M.
 (2) The concentration of CO_3^{2-} is greater than that of HCO_3^- .
 (3) The concentration of H^+ and HCO_3^- are approximately equal.
 (4) The concentration of H^+ is double that of CO_3^{2-} .

18. (3)
 Sol : A $\rightarrow \text{H}_2\text{CO}_3 \rightleftharpoons \text{H}^+ + \text{HCO}_3^- \quad K_1 = 4.2 \times 10^{-7}$
 B $\rightarrow \text{HCO}_3^- \rightleftharpoons \text{H}^+ + \text{CO}_3^{2-} \quad K_2 = 4.8 \times 10^{-11}$

As $K_2 \ll K_1$

$$\text{All major } [\text{H}^+]_{\text{total}} \approx [\text{H}^+]_{\text{A}}$$

$$\text{and from I equilibrium, } [\text{H}^+]_{\text{A}} \approx [\text{HCO}_3^-] \approx [\text{H}^+]_{\text{total}}$$

$$[\text{CO}_3^{2-}] \text{ is negligible compared to } [\text{HCO}_3^-] \text{ or } [\text{H}^+]_{\text{total}}$$

19. The edge length of a face centered cubic cell of an ionic substance is 508 pm. If the radius of the cation is 110 pm, the radius of the anion is
 (1) 288 pm (2) 398 pm (3) 618 pm (4) 144 pm
 19. (4)

- Sol : For an ionic substance in FCC arrangement,
 $2(r^+ + r^-) = \text{edge length}$
 $2(110 + r^-) = 508$
 $r^- = 144 \text{ pm}$

20. The correct order of increasing basicity of the given conjugate bases ($R = \text{CH}_3$) is
 (1) $\text{RCOO}^- < \text{HC} \equiv \text{C}^- < \bar{\text{R}} < \bar{\text{NH}}_2$ (2) $\bar{\text{R}} < \text{HC} \equiv \text{C}^- < \text{RCOO}^- < \bar{\text{NH}}_2$
 (3) $\text{RCOO}^- < \bar{\text{NH}}_2 < \text{HC} \equiv \text{C}^- < \bar{\text{R}}$ (4) $\text{RCOO}^- < \text{HC} \equiv \text{C}^- < \bar{\text{NH}}_2 < \bar{\text{R}}$

20. (4)
 Sol : Correct order of increasing basic strength is
 $R-\text{COO}^{(-)} < \text{CH} \equiv \text{C}^{(-)} < \text{NH}_2^{(-)} < R^{(-)}$

21. The correct sequence which shows decreasing order of the ionic radii of the elements is
 (1) $\text{Al}^{3+} > \text{Mg}^{2+} > \text{Na}^+ > \text{F}^- > \text{O}^{2-}$ (2) $\text{Na}^+ > \text{Mg}^{2+} > \text{Al}^{3+} > \text{O}^{2-} > \text{F}^-$
 (3) $\text{Na}^+ > \text{F}^- > \text{Mg}^{2+} > \text{O}^{2-} > \text{Al}^{3+}$ (4) $\text{O}^{2-} > \text{F}^- > \text{Na}^+ > \text{Mg}^{2+} > \text{Al}^{3+}$

21. (4)
 Sol : For isoelectronic species higher the $\frac{Z}{e}$ ratio, smaller the ionic radius

$$\frac{z}{e} \text{ for } O^{2-} = \frac{8}{10} = 0.8$$

$$F^- = \frac{9}{10} = 0.9$$

$$Na^+ = \frac{11}{10} = 1.1$$

$$Mg^{2+} = \frac{12}{10} = 1.2$$

$$Al^{3+} = \frac{13}{10} = 1.3$$

22. Solubility product of silver bromide is 5.0×10^{-13} . The quantity of potassium bromide (molar mass taken as $120 \text{ g of mol}^{-1}$) to be added to 1 litre of 0.05 M solution of silver nitrate to start the precipitation of AgBr is

(1) $1.2 \times 10^{-10} \text{ g}$ (2) $1.2 \times 10^{-9} \text{ g}$ (3) $6.2 \times 10^{-5} \text{ g}$ (4) $5.0 \times 10^{-8} \text{ g}$

22. (2)



Precipitation starts when ionic product just exceeds solubility product

$$K_{sp} = [Ag^+][Br^-]$$

$$[Br^-] = \frac{K_{sp}}{[Ag^+]} = \frac{5 \times 10^{-13}}{0.05} = 10^{-11}$$

i.e., precipitation just starts when 10^{-11} moles of KBr is added to 1L of $AgNO_3$ solution.

No. of moles of KBr to be added = 10^{-11}

\therefore weight of KBr to be added = $10^{-11} \times 120$
= $1.2 \times 10^{-9} \text{ g}$

23. The Gibbs energy for the decomposition of Al_2O_3 at $500^\circ C$ is as follows :

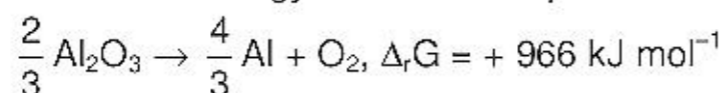

The potential difference needed for electrolytic reduction of Al_2O_3 at $500^\circ C$ is at least

(1) 4.5 V (2) 3.0 V (3) 2.5 V (4) 5.0 V

23. (3)

Sol : $\Delta G = -nFE \Rightarrow E = \frac{-\Delta G}{nF}$

$$E = -\frac{966 \times 10^3}{4 \times 96500}$$

$$= -2.5 \text{ V}$$

\therefore The potential difference needed for the reduction = 2.5 V

24. At $25^\circ C$, the solubility product of $Mg(OH)_2$ is 1.0×10^{-11} . At which pH, will Mg^{2+} ions start precipitating in the form of $Mg(OH)_2$ from a solution of 0.001 M Mg^{2+} ions ?

(1) 9 (2) 10 (3) 11 (4) 8

24. (2)

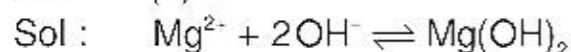

$$K_{sp} = [Mg^{2+}][OH^-]^2$$

$$[OH^-] = \sqrt{\frac{K_{sp}}{[Mg^{2+}]}} = 10^{-4}$$

$\therefore p^{OH} = 4$ and $p^H = 10$

25. Percentage of free space in cubic close packed structure and in body centred packed structure are respectively

- (1) 30% and 26% (2) 26% and 32% (3) 32% and 48% (4) 48% and 26%

25. (2)

Sol : packing fraction of cubic close packing and body centred packing are 0.74 and 0.68 respectively.

26. Out of the following, the alkene that exhibits optical isomerism is

- (1) 3-methyl-2-pentene (2) 4-methyl-1-pentene
(3) 3-methyl-1-pentene (4) 2-methyl-2-pentene

26. (3)

Sol :

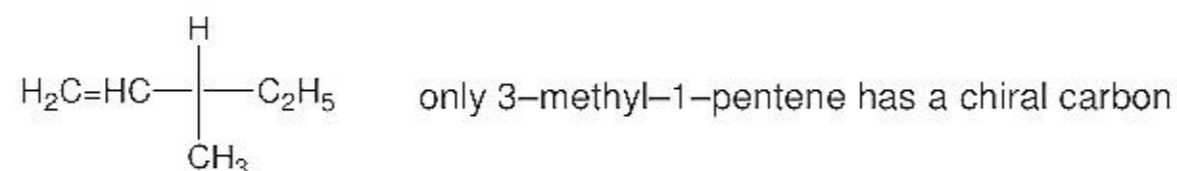

27. Biuret test is not given by

- (1) carbohydrates (2) polypeptides (3) urea (4) proteins

27. (1)

Sol : It is a test characteristic of amide linkage. Urea also has amide linkage like proteins.

28. The correct order of $E_{M^{2+}/M}^0$ values with negative sign for the four successive elements Cr, Mn, Fe and Co is

- (1) Mn > Cr > Fe > Co (2) Cr > Fe > Mn > Co (3) Fe > Mn > Cr > Co (4) Cr > Mn > Fe > Co

28. (1)

29. The polymer containing strong intermolecular forces e.g. hydrogen bonding, is

- (1) teflon (2) nylon 6,6 (3) polystyrene (4) natural rubber

29. (2)

Sol : nylon 6,6 is a polymer of adipic acid and hexamethylene diamine

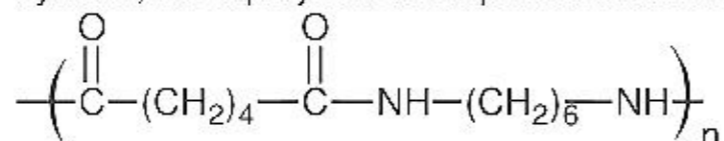

30. For a particular reversible reaction at temperature T, ΔH and ΔS were found to be both +ve. If T_e is the temperature at equilibrium, the reaction would be spontaneous when

- (1) $T_e > T$ (2) $T > T_e$ (3) T_e is 5 times T (4) $T = T_e$

30. (2)

Sol : $\Delta G = \Delta H - T\Delta S$

at equilibrium, $\Delta G = 0$

for a reaction to be spontaneous ΔG should be negative

$\therefore T > T_e$

PART B: PHYSICS

31. A rectangular loop has a sliding connector PQ of length ℓ and resistance $R \Omega$ and it is moving with a speed v as shown. The set-up is placed in a uniform magnetic field going into the plane of the paper. The three currents I_1 , I_2 and I are

- (1) $I_1 = -I_2 = \frac{B\ell v}{R}, I = \frac{2B\ell v}{R}$
 (2) $I_1 = I_2 = \frac{B\ell v}{3R}, I = \frac{2B\ell v}{3R}$
 (3) $I_1 = I_2 = I = \frac{B\ell v}{R}$
 (4) $I_1 = I_2 = \frac{B\ell v}{6R}, I = \frac{B\ell v}{3R}$

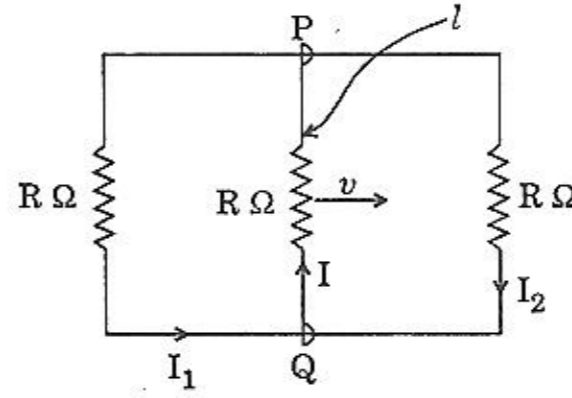

31. 2

Sol. A moving conductor is equivalent to a battery of emf = $vB\ell$ (motion emf)
 Equivalent circuit

$$I = I_1 + I_2$$

applying Kirchoff's law

$$I_1 R + IR - vB\ell = 0 \quad \dots\dots\dots(1)$$

$$I_2 R + IR - vB\ell = 0 \quad \dots\dots\dots(2)$$

adding (1) & (2)

$$2IR + IR = 2vB\ell$$

$$I = \frac{2vB\ell}{3R}$$

$$I_1 = I_2 = \frac{vB\ell}{3R}$$

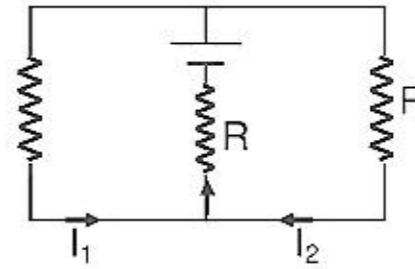

32. Let C be the capacitance of a capacitor discharging through a resistor R. Suppose t_1 is the time taken for the energy stored in the capacitor to reduce to half its initial value and t_2 is the time taken for the charge to reduce to one-fourth its initial value. Then the ratio t_1/t_2 will be

- (1) 1 (2) $\frac{1}{2}$ (3) $\frac{1}{4}$ (4) 2

32. 3

Sol. $U = \frac{1}{2} \frac{q^2}{C} = \frac{1}{2C} (q_0 e^{-t/T})^2 = \frac{q_0^2}{2C} e^{-2t/T}$ (where $\tau = CR$)

$$U = U_1 e^{-2t_1/T}$$

$$\frac{1}{2} U_1 = U_1 e^{-2t_1/T}$$

$$\frac{1}{2} = e^{-2t_1/T} \Rightarrow t_1 = \frac{T}{2} \ln 2$$

Now $q = q_0 e^{-t/T}$

$$\frac{1}{4} q_0 = q_0 e^{-t_2/T}$$

$$t_2 = T \ln 4 = 2T \ln 2$$

$$\therefore \frac{t_1}{t_2} = \frac{1}{4}$$

Directions: Questions number 33 – 34 contain Statement-1 and Statement-2. Of the four choices given after the statements, choose the one that best describes the two statements.

33. **Statement-1** : Two particles moving in the same direction do not lose all their energy in a completely inelastic collision.
Statement-2 : Principle of conservation of momentum holds true for all kinds of collisions.

- (1) Statement-1 is true, Statement-2 is true; Statement-2 is the correct explanation of Statement-1.
 (2) Statement-1 is true, Statement-2 is true; Statement-2 is not the correct explanation of Statement-1.
 (3) Statement-1 is false, Statement-2 is true.
 (4) Statement-1 is true, Statement-2 is false.

33.
Sol.



If it is a completely inelastic collision then

$$m_1 v_1 + m_2 v_2 = (m_1 + m_2) v$$

$$v = \frac{m_1 v_1 + m_2 v_2}{m_1 + m_2}$$

$$\text{K.E} = \frac{p_1^2}{2m_1} + \frac{p_2^2}{2m_2}$$

as \bar{p}_1 and \bar{p}_2 both simultaneously cannot be zero
 therefore total KE cannot be lost.

34. **Statement-1** : When ultraviolet light is incident on a photocell, its stopping potential is V_0 and the maximum kinetic energy of the photoelectrons is K_{max} . When the ultraviolet light is replaced by X-rays, both V_0 and K_{max} increase.

Statement-2 : Photoelectrons are emitted with speeds ranging from zero to a maximum value because of the range of frequencies present in the incident light.

- (1) Statement-1 is true, Statement-2 is true; Statement-2 is the correct explanation of Statement-1.
 (2) Statement-1 is true, Statement-2 is true; Statement-2 is not the correct explanation of Statement-1.
 (3) Statement-1 is false, Statement-2 is true.
 (4) Statement-1 is true, Statement-2 is false.

34.
Sol.

Since the frequency of ultraviolet light is less than the frequency of X-rays, the energy of each incident photon will be more for X-rays

$$\text{K.E}_{\text{photoelectron}} = h\nu - \phi$$

Stopping potential is to stop the fastest photoelectron

$$V_0 = \frac{h\nu}{e} - \frac{\phi}{e}$$

so, $K.E_{\text{max}}$ and V_0 both increases.

But K.E ranges from zero to $K.E_{\text{max}}$ because of loss of energy due to subsequent collisions before getting ejected and not due to range of frequencies in the incident light.

35. A ball is made of a material of density ρ where $\rho_{\text{oil}} < \rho < \rho_{\text{water}}$ with ρ_{oil} and ρ_{water} representing the densities of oil and water, respectively. The oil and water are immiscible. If the above ball is in equilibrium in a mixture of this oil and water, which of the following pictures represents its equilibrium position ?

(1)

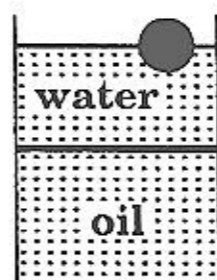

(2)

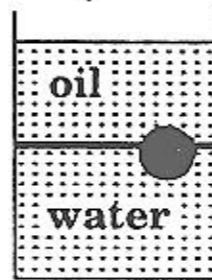

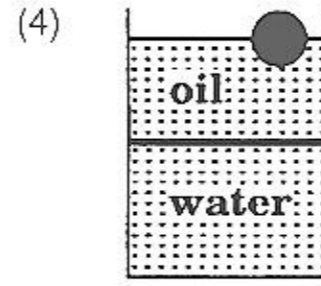
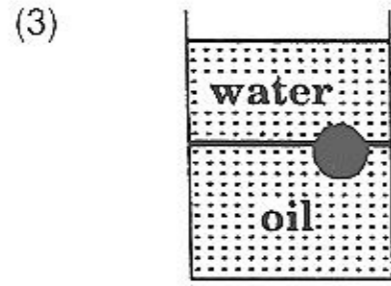

35. 2

Sol. $\rho_{oil} < \rho < \rho_{water}$

Oil is the least dense of them so it should settle at the top with water at the base. Now the ball is denser than oil but less denser than water. So, it will sink through oil but will not sink in water. So it will stay at the oil-water interface.

36. A particle is moving with velocity $\vec{v} = K(y\hat{i} + x\hat{j})$, where K is a constant. The general equation for its path is

- (1) $y = x^2 + \text{constant}$ (2) $y^2 = x + \text{constant}$ (3) $xy = \text{constant}$ (4) $y^2 = x^2 + \text{constant}$

36. 4

Sol. $\vec{v} = Ky\hat{i} + Kx\hat{j}$

$$\frac{dx}{dt} = Ky, \quad \frac{dy}{dt} = Kx$$

$$\frac{dy}{dx} = \frac{dy}{dt} \times \frac{dt}{dx} = \frac{Kx}{Ky}$$

$$y dy = x dx$$

$$y^2 = x^2 + c.$$

37. Two long parallel wires are at a distance $2d$ apart. They carry steady equal current flowing out of the plane of the paper as shown. The variation of the magnetic field along the line XX' is given by

(1)

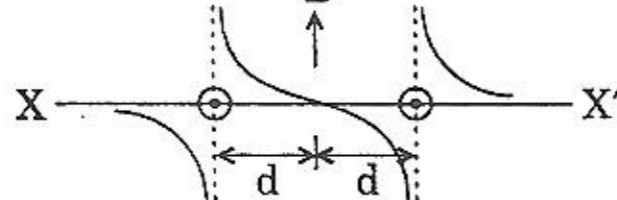

(2)

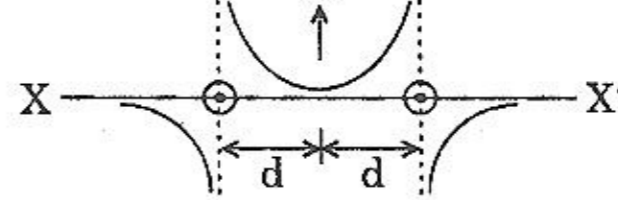

(3)

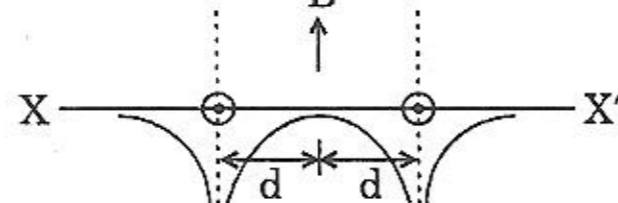

(4)

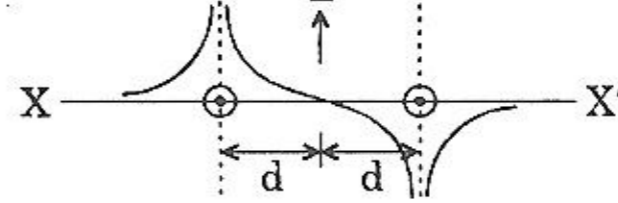

37. 1

Sol. The magnetic field in between because of each will be in opposite direction

$$B_{in\ between} = \frac{\mu_0 i}{2\pi x} \hat{j} - \frac{\mu_0 i}{2\pi(2d-x)} (-\hat{j})$$

$$= \frac{\mu_0 i}{2\pi} \left[\frac{1}{x} + \frac{1}{2d-x} \right] (\hat{j})$$

at $x = d$, $B_{in\ between} = 0$

for $x < d$, $B_{in\ between} = (\hat{j})$

for $x > d$, $B_{in\ between} = (-\hat{j})$

towards x net magnetic field will add up and direction will be $(-\hat{j})$

towards x' net magnetic field will add up and direction will be (\hat{j})

38. In the circuit shown below, the key K is closed at $t = 0$. The current through the battery is

- (1) $\frac{VR_1R_2}{\sqrt{R_1^2 + R_2^2}}$ at $t = 0$ and $\frac{V}{R_2}$ at $t = \infty$
- (2) $\frac{V}{R_2}$ at $t = 0$ and $\frac{V(R_1 + R_2)}{R_1R_2}$ at $t = \infty$
- (3) $\frac{V}{R_2}$ at $t = 0$ and $\frac{VR_1R_2}{\sqrt{R_1^2 + R_2^2}}$ at $t = \infty$
- (4) $\frac{V(R_1 + R_2)}{R_1R_2}$ at $t = 0$ and $\frac{V}{R_2}$ at $t = \infty$

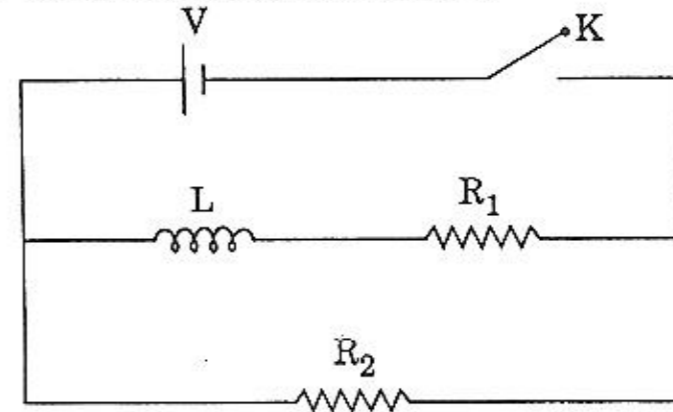

38. 2
Sol. At $t = 0$, inductor behaves like an infinite resistance

So at $t = 0$, $i = \frac{V}{R_2}$

and at $t = \infty$, inductor behaves like a conducting wire

$$i = \frac{V}{R_{eq}} = \frac{V(R_1 + R_2)}{R_1R_2}$$

39. The figure shows the position – time ($x - t$) graph of one-dimensional motion of a body of mass 0.4 kg. The magnitude of each impulse is

- (1) 0.4 Ns
- (2) 0.8 Ns
- (3) 1.6 Ns
- (4) 0.2 Ns

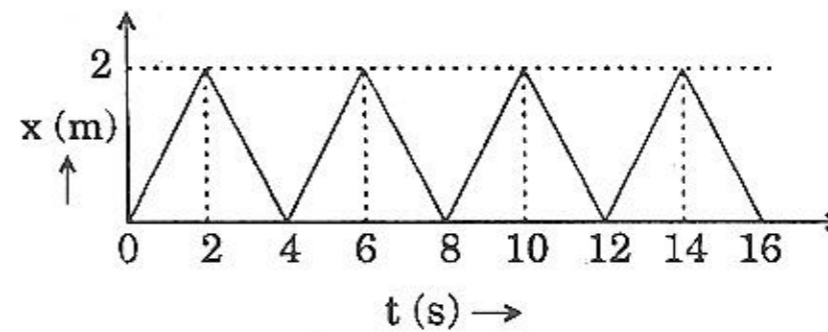

39. 2
Sol. From the graph, it is a straight line so, uniform motion. Because of impulse direction of velocity changes as can be seen from the slope of the graph.

Initial velocity = $\frac{2}{2} = 1 \text{ m/s}$

Final velocity = $-\frac{2}{2} = -1 \text{ m/s}$

$$\bar{P}_i = 0.4 \text{ N-s}$$

$$\bar{P}_f = -0.4 \text{ N-s}$$

$$\bar{J} = \bar{P}_f - \bar{P}_i = -0.4 - 0.4 = -0.8 \text{ N-s} \quad (\bar{J} = \text{impulse})$$

$$|\bar{J}| = 0.8 \text{ N-s}$$

Directions : Questions number 40 – 41 are based on the following paragraph.

A nucleus of mass $M + \Delta m$ is at rest and decays into two daughter nuclei of equal mass $\frac{M}{2}$ each.

Speed of light is c .

40. The binding energy per nucleon for the parent nucleus is E_1 and that for the daughter nuclei is E_2 . Then
 (1) $E_2 = 2E_1$ (2) $E_1 > E_2$ (3) $E_2 > E_1$ (4) $E_1 = 2E_2$

40. 3
Sol. After decay, the daughter nuclei will be more stable hence binding energy per nucleon will be more than that of their parent nucleus.

41. The speed of daughter nuclei is
 (1) $c \frac{\Delta m}{M + \Delta m}$ (2) $c \sqrt{\frac{2\Delta m}{M}}$ (3) $c \sqrt{\frac{\Delta m}{M}}$ (4) $c \sqrt{\frac{\Delta m}{M + \Delta m}}$

41. 2
Sol. Conserving the momentum

$$0 = \frac{M}{2} V_1 - \frac{M}{2} V_2$$

$$V_1 = V_2 \quad \dots\dots\dots(1)$$

$$\Delta mc^2 = \frac{1}{2} \cdot \frac{M}{2} V_1^2 + \frac{1}{2} \cdot \frac{M}{2} V_2^2 \quad \dots\dots\dots(2)$$

$$\Delta mc^2 = \frac{M}{2} V_1^2$$

$$\frac{2\Delta mc^2}{M} = V_1^2$$

$$V_1 = c \sqrt{\frac{2\Delta m}{M}}$$

42. A radioactive nucleus (initial mass number A and atomic number Z) emits 3 α -particles and 2 positrons. The ratio of number of neutrons to that of protons in the final nucleus will be
 (1) $\frac{A-Z-8}{Z-4}$ (2) $\frac{A-Z-4}{Z-8}$ (3) $\frac{A-Z-12}{Z-4}$ (4) $\frac{A-Z-4}{Z-2}$

42. 2
Sol. In positive beta decay a proton is transformed into a neutron and a positron is emitted.

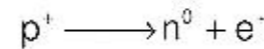

no. of neutrons initially was $A - Z$
 no. of neutrons after decay $(A - Z) - 3 \times 2$ (due to alpha particles) + 2×1 (due to positive beta decay)
 The no. of proton will reduce by 8. [as 3×2 (due to alpha particles) + 2 (due to positive beta decay)]
 Hence atomic number reduces by 8.

43. A thin semi-circular ring of radius r has a positive charge q distributed uniformly over it. The net field \vec{E} at the centre O is

- (1) $\frac{q}{4\pi^2 \epsilon_0 r^2} \hat{j}$ (2) $-\frac{q}{4\pi^2 \epsilon_0 r^2} \hat{j}$
 (3) $-\frac{q}{2\pi^2 \epsilon_0 r^2} \hat{j}$ (4) $\frac{q}{2\pi^2 \epsilon_0 r^2} \hat{j}$

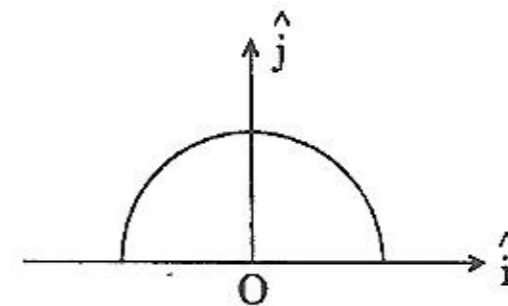

43. 3
Sol. Linear charge density $\lambda = \left(\frac{q}{\pi r}\right)$

$$E = \int dE \sin \theta (-\hat{j}) = \int \frac{K \cdot dq}{r^2} \sin \theta (-\hat{j})$$

$$E = \frac{K}{r^2} \int \frac{qr}{\pi r} d\theta \sin \theta (-\hat{j})$$

$$= \frac{K q}{r^2} \int_0^\pi \sin \theta (-\hat{j})$$

$$= \frac{q}{2\pi^2 \epsilon_0 r^2} (-\hat{j})$$

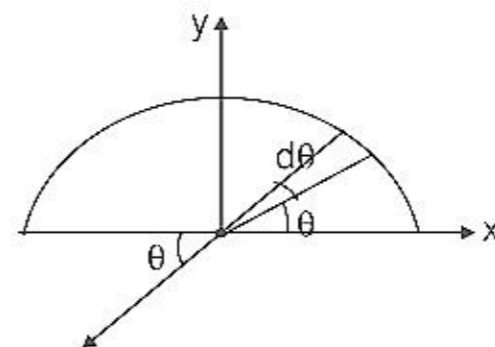

44. The combination of gates shown below yields
 (1) OR gate (2) NOT gate
 (3) XOR gate (4) NAND gate

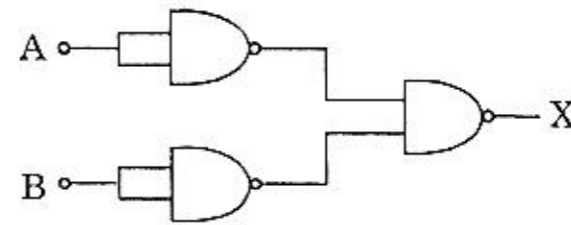

44. 1
Sol. Truth table for given combination is

A	B	X
0	0	0
0	1	1
1	0	1
1	1	1

This comes out to be truth table of OR gate

45. A diatomic ideal gas is used in a Car engine as the working substance. If during the adiabatic expansion part of the cycle, volume of the gas increases from V to $32V$ the efficiency of the engine is
 (1) 0.5 (2) 0.75 (3) 0.99 (4) 0.25

45. 2
Sol. The efficiency of cycle is

$$\eta = 1 - \frac{T_2}{T_1}$$

for adiabatic process

$$TV^{\gamma-1} = \text{constant}$$

For diatomic gas $\gamma = \frac{7}{5}$

$$T_1 V_1^{\gamma-1} = T_2 V_2^{\gamma-1}$$

$$T_1 = T_2 \left(\frac{V_2}{V_1} \right)^{\gamma-1}$$

$$T_1 = T_2 (32)^{\frac{7}{5}-1}$$

$$= T_2 (2^5)^{\frac{2}{5}}$$

$$= T_2 \times 4$$

$$T_1 = 4T_2$$

$$\eta = \left(1 - \frac{1}{4} \right) = \frac{3}{4} = 0.75$$

46. If a source of power 4 kW produces 10^{20} photons/second, the radiation belong to a part of the spectrum called
 (1) X-rays (2) ultraviolet rays (3) microwaves (4) γ -rays

46. 1
Sol. $4 \times 10^3 = 10^{20} \times hf$

$$f = \frac{4 \times 10^3}{10^{20} \times 6.023 \times 10^{-34}}$$

$$f = 6.03 \times 10^{16} \text{ Hz}$$

The obtained frequency lies in the band of X-rays.

47. The respective number of significant figures for the numbers 23.023, 0.0003 and 2.1×10^{-3} are
 (1) 5, 1, 2 (2) 5, 1, 5 (3) 5, 5, 2 (4) 4, 4, 2

47. 1

48. In a series LCR circuit $R = 200 \Omega$ and the voltage and the frequency of the main supply is 220 V and 50 Hz respectively. On taking out the capacitance from the circuit the current lags behind the voltage by 30° . On taking out the inductor from the circuit the current leads the voltage by 30° . The power dissipated in the LCR circuit is
 (1) 305 W (2) 210 W (3) Zero W (4) 242 W

48. 4
Sol. The given circuit is under resonance as $X_L = X_C$
 Hence power dissipated in the circuit is

$$P = \frac{V^2}{R} = 242 \text{ W}$$

49. Let there be a spherically symmetric charge distribution with charge density varying as $\rho(r) = \rho_0 \left(\frac{5}{4} - \frac{r}{R} \right)$ upto $r = R$, and $\rho(r) = 0$ for $r > R$, where r is the distance from the origin. The electric field at a distance $r (r < R)$ from the origin is given by

- (1) $\frac{4\pi\rho_0 r}{3\epsilon_0} \left(\frac{5}{3} - \frac{r}{R} \right)$ (2) $\frac{\rho_0 r}{4\epsilon_0} \left(\frac{5}{3} - \frac{r}{R} \right)$ (3) $\frac{4\rho_0 r}{3\epsilon_0} \left(\frac{5}{4} - \frac{r}{R} \right)$ (4) $\frac{\rho_0 r}{3\epsilon_0} \left(\frac{5}{4} - \frac{r}{R} \right)$

49. 2
Sol. Apply shell theorem the total charge upto distance r can be calculated as followed

$$\begin{aligned} dq &= 4\pi r^2 \cdot dr \cdot \rho \\ &= 4\pi r^2 \cdot dr \cdot \rho_0 \left[\frac{5}{4} - \frac{r}{R} \right] \\ &= 4\pi\rho_0 \left[\frac{5}{4} r^2 dr - \frac{r^3}{R} dr \right] \\ \int dq = q &= 4\pi\rho_0 \int_0^r \left(\frac{5}{4} r^2 dr - \frac{r^3}{R} dr \right) \\ &= 4\pi\rho_0 \left[\frac{5}{4} \frac{r^3}{3} - \frac{1}{R} \frac{r^4}{4} \right] \end{aligned}$$

$$\begin{aligned} E &= \frac{kq}{r^2} \\ &= \frac{1}{4\pi\epsilon_0} \frac{1}{r^2} \cdot 4\pi\rho_0 \left[\frac{5}{4} \left(\frac{r^3}{3} \right) - \frac{r^4}{4R} \right] \\ E &= \frac{\rho_0 r}{4\epsilon_0} \left[\frac{5}{3} - \frac{r}{R} \right] \end{aligned}$$

50. The potential energy function for the force between two atoms in a diatomic molecule is approximately given by $U(x) = \frac{a}{x^{12}} - \frac{b}{x^6}$, where a and b are constants and x is the distance between the atoms. If the dissociation energy of the molecule is $D = [U(x = \infty) - U_{\text{at equilibrium}}]$, D is

- (1) $\frac{b^2}{2a}$ (2) $\frac{b^2}{12a}$ (3) $\frac{b^2}{4a}$ (4) $\frac{b^2}{6a}$

50. 3
Sol. $U(x) = \frac{a}{x^{12}} - \frac{b}{x^6}$

$$\begin{aligned} U(x = \infty) &= 0 \\ \text{as, } F &= -\frac{dU}{dx} = -\left[\frac{12a}{x^{13}} + \frac{6b}{x^7} \right] \\ \text{at equilibrium, } F &= 0 \end{aligned}$$

$$\therefore x^6 = \frac{2a}{b}$$

$$\therefore U_{\text{at equilibrium}} = \frac{a}{\left(\frac{2a}{b}\right)^2} - \frac{b}{\left(\frac{2a}{b}\right)} = \frac{-b^2}{4a}$$

$$\therefore D = [U(x = \infty) - U_{\text{at equilibrium}}] = \frac{b^2}{4a}$$

51. Two identical charged spheres are suspended by strings of equal lengths. The strings make an angle of 30° with each other. When suspended in a liquid of density 0.8 g cm^{-3} , the angle remains the same. If density of the material of the sphere is 16 g cm^{-3} , the dielectric constant of the liquid is
 (1) 4 (2) 3 (3) 2 (4) 1

51. 3
Sol.

From F.B.D of sphere, using Lami's theorem

$$\frac{F}{mg} = \tan \theta \quad \dots\dots\dots(i)$$

when suspended in liquid, as θ remains same,

$$\therefore \frac{F'}{mg\left(1 - \frac{\rho}{d}\right)} = \tan \theta \quad \dots\dots\dots(ii)$$

using (i) and (ii)

$$\frac{F}{mg} = \frac{F'}{mg\left(1 - \frac{\rho}{d}\right)} \text{ where, } F' = \frac{F}{K}$$

$$\therefore \frac{F}{mg} = \frac{F'}{mg K\left(1 - \frac{\rho}{d}\right)}$$

$$\text{or } K = \frac{1}{1 - \frac{\rho}{d}} = 2$$

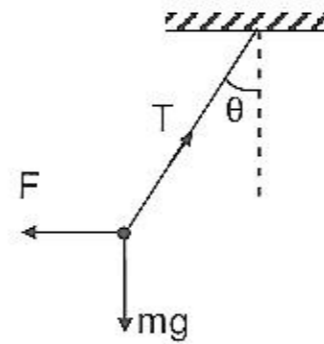

52. Two conductors have the same resistance at 0°C but their temperature coefficients of resistance are α_1 and α_2 . The respective temperature coefficients of their series and parallel combinations are nearly

- (1) $\frac{\alpha_1 + \alpha_2}{2}, \alpha_1 + \alpha_2$ (2) $\alpha_1 + \alpha_2, \frac{\alpha_1 + \alpha_2}{2}$ (3) $\alpha_1 + \alpha_2, \frac{\alpha_1 \alpha_2}{\alpha_1 + \alpha_2}$ (4) $\frac{\alpha_1 + \alpha_2}{2}, \frac{\alpha_1 + \alpha_2}{2}$

52. 4
Sol.

Let R_0 be the initial resistance of both conductors

$$\therefore \text{At temperature } \theta \text{ their resistance will be, } R_1 = R_0(1 + \alpha_1\theta) \text{ and } R_2 = R_0(1 + \alpha_2\theta)$$

$$\text{for, series combination, } R_s = R_1 + R_2$$

$$R_{s0}(1 + \alpha_s\theta) = R_0(1 + \alpha_1\theta) + R_0(1 + \alpha_2\theta)$$

$$\text{where } R_{s0} = R_0 + R_0 = 2R_0$$

$$\therefore 2R_0(1 + \alpha_s\theta) = 2R_0 + R_0\theta(\alpha_1 + \alpha_2)$$

$$\text{or } \alpha_s = \frac{\alpha_1 + \alpha_2}{2}$$

$$\text{for parallel combination, } R_p = \frac{R_1 R_2}{R_1 + R_2}$$

$$R_{p0}(1 + \alpha_p \theta) = \frac{R_0(1 + \alpha_1 \theta)R_0(1 + \alpha_2 \theta)}{R_0(1 + \alpha_1 \theta) + R_0(1 + \alpha_2 \theta)}$$

where, $R_{p0} = \frac{R_0 R_0}{R_0 + R_0} = \frac{R_0}{2}$

$$\therefore \frac{R_0}{2}(1 + \alpha_p \theta) = \frac{R_0^2(1 + \alpha_1 \theta + \alpha_2 \theta + \alpha_1 \alpha_2 \theta)}{R_0(2 + \alpha_1 \theta + \alpha_2 \theta)}$$

as α_1 and α_2 are small quantities

$\therefore \alpha_1 \alpha_2$ is negligible

$$\text{or } \alpha_p = \frac{\alpha_1 + \alpha_2}{2 + (\alpha_1 + \alpha_2)\theta} = \frac{\alpha_1 + \alpha_2}{2} [1 - (\alpha_1 + \alpha_2)\theta]$$

as $(\alpha_1 + \alpha_2)^2$ is negligible

$$\therefore \alpha_p = \frac{\alpha_1 + \alpha_2}{2}$$

53. A point P moves in counter-clockwise direction on a circular path as shown in the figure. The movement of 'P' is such that it sweeps out a length $s = t^3 + 5$, where s is in metres and t is in seconds. The radius of the path is 20 m. The acceleration of 'P' when $t = 2$ s is nearly

- (1) 13 m/s^2 (2) 12 m/s^2
 (3) 7.2 m/s^2 (4) 14 m/s^2

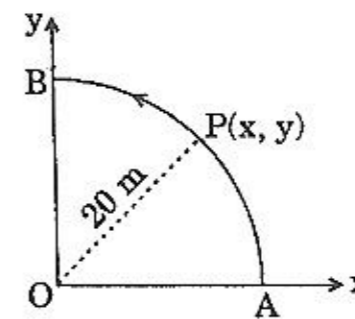

53. 4
Sol. $S = t^3 + 5$

$$\therefore \text{speed, } v = \frac{ds}{dt} = 3t^2$$

and rate of change of speed $= \frac{dv}{dt} = 6t$

\therefore tangential acceleration at $t = 2$ s, $a_t = 6 \times 2 = 12 \text{ m/s}^2$
 at $t = 2$ s, $v = 3(2)^2 = 12 \text{ m/s}$

\therefore centripetal acceleration, $a_c = \frac{v^2}{R} = \frac{144}{20} \text{ m/s}^2$

\therefore net acceleration $= \sqrt{a_t^2 + a_c^2}$
 $\approx 14 \text{ m/s}^2$

54. Two fixed frictionless inclined plane making an angle 30° and 60° with the vertical are shown in the figure. Two block A and B are placed on the two planes. What is the relative vertical acceleration of A with respect to B ?

- (1) 4.9 ms^{-2} in horizontal direction
 (2) 9.8 ms^{-2} in vertical direction
 (3) zero
 (4) 4.9 ms^{-2} in vertical direction

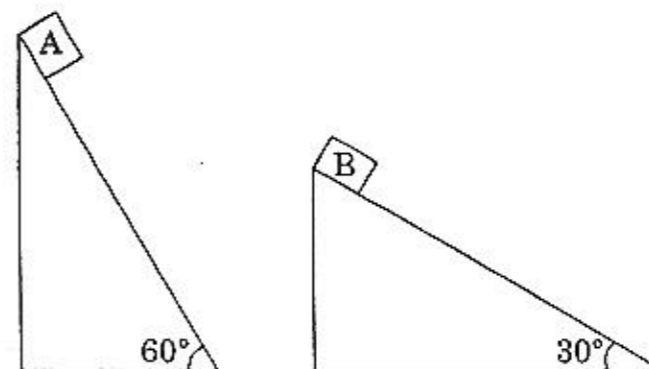

54. 4
Sol. $mg \sin \theta = ma$

$$\therefore a = g \sin \theta$$

where a is along the inclined plane

\therefore vertical component of acceleration is $g \sin^2 \theta$

\therefore relative vertical acceleration of A with respect to B is

$$g[\sin^2 60 - \sin^2 30] = \frac{g}{2} = 4.9 \text{ m/s}^2 \text{ in vertical direction.}$$

55. For a particle in uniform circular motion the acceleration \vec{a} at a point P(R, θ) on the circle of radius R is (here θ is measured from the x-axis)

- (1) $-\frac{v^2}{R} \cos\theta \hat{i} + \frac{v^2}{R} \sin\theta \hat{j}$ (2) $-\frac{v^2}{R} \sin\theta \hat{i} + \frac{v^2}{R} \cos\theta \hat{j}$
 (3) $-\frac{v^2}{R} \cos\theta \hat{i} - \frac{v^2}{R} \sin\theta \hat{j}$ (4) $\frac{v^2}{R} \hat{i} + \frac{v^2}{R} \hat{j}$

55. 3
Sol. For a particle in uniform circular motion,

$$\vec{a} = \frac{v^2}{R} \text{ towards centre of circle}$$

$$\therefore \vec{a} = \frac{v^2}{R} (-\cos\theta \hat{i} - \sin\theta \hat{j})$$

$$\text{or } \vec{a} = -\frac{v^2}{R} \cos\theta \hat{i} - \frac{v^2}{R} \sin\theta \hat{j}$$

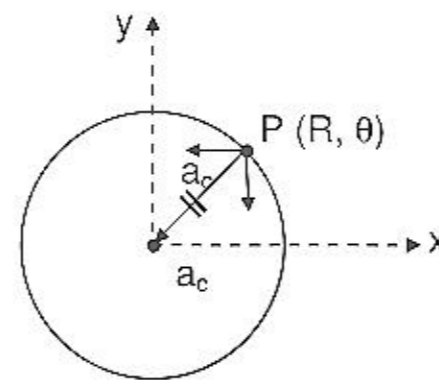

Directions: Questions number 56 – 58 are based on the following paragraph.

An initially parallel cylindrical beam travels in a medium of refractive index $\mu(l) = \mu_0 + \mu_2 l$, where μ_0 and μ_2 are positive constants and l is the intensity of the light beam. The intensity of the beam is decreasing with increasing radius.

56. As the beam enters the medium, it will
 (1) diverge
 (2) converge
 (3) diverge near the axis and converge near the periphery
 (4) travel as a cylindrical beam

56. 2
Sol. As intensity is maximum at axis,
 $\therefore \mu$ will be maximum and speed will be minimum on the axis of the beam.
 \therefore beam will converge.

57. The initial shape of the wave front of the beam is
 (1) convex
 (2) concave
 (3) convex near the axis and concave near the periphery
 (4) planar

57. 4
Sol. For a parallel cylindrical beam, wavefront will be planar.

58. The speed of light in the medium is
 (1) minimum on the axis of the beam (2) the same everywhere in the beam
 (3) directly proportional to the intensity l (4) maximum on the axis of the beam

58. 1

59. A small particle of mass m is projected at an angle θ with the x -axis with an initial velocity v_0 in the x - y plane as shown in the figure. At a time $t < \frac{v_0 \sin \theta}{g}$, the angular momentum of the particle is

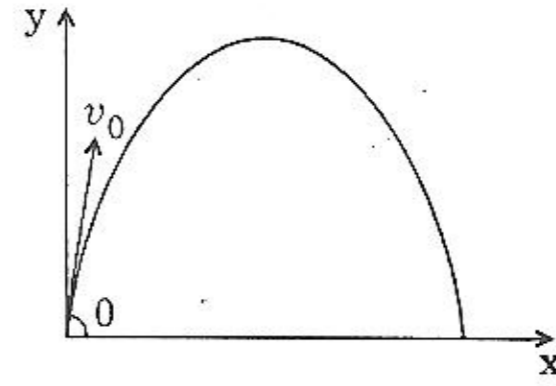

- (1) $-mgv_0 t^2 \cos \theta \hat{j}$ (2) $mgv_0 t \cos \theta \hat{k}$
 (3) $-\frac{1}{2}mgv_0 t^2 \cos \theta \hat{k}$ (4) $\frac{1}{2}mgv_0 t^2 \cos \theta \hat{i}$

where \hat{i} , \hat{j} and \hat{k} are unit vectors along x , y and z -axis respectively.

59. 3

Sol. $\vec{L} = m(\vec{r} \times \vec{v})$

$$\begin{aligned} \vec{L} &= m \left[v_0 \cos \theta \hat{i} + (v_0 \sin \theta - \frac{1}{2}gt^2) \hat{j} \right] \times \left[v_0 \cos \theta \hat{i} + (v_0 \sin \theta - gt) \hat{j} \right] \\ &= mv_0 \cos \theta \left[-\frac{1}{2}gt \right] \hat{k} \\ &= -\frac{1}{2}mgv_0 t^2 \cos \theta \hat{k} \end{aligned}$$

60. The equation of a wave on a string of linear mass density 0.04 kg m^{-1} is given by $y = 0.02(m) \sin \left[2\pi \left(\frac{t}{0.04(s)} - \frac{x}{0.50(m)} \right) \right]$. The tension in the string is

- (1) 4.0 N (2) 12.5 N (3) 0.5 N (4) 6.25 N

60. 4

Sol. $T = \mu v^2 = \mu \frac{\omega^2}{k^2} = 0.04 \frac{(2\pi/0.004)^2}{(2\pi/0.50)^2} = 6.25 \text{ N}$

PART C: MATHEMATICS

61. Let $\cos(\alpha + \beta) = \frac{4}{5}$ and let $\sin(\alpha - \beta) = \frac{5}{13}$, where $0 \leq \alpha, \beta \leq \frac{\pi}{4}$, then $\tan 2\alpha =$

- (1) $\frac{56}{33}$ (2) $\frac{19}{12}$ (3) $\frac{20}{7}$ (4) $\frac{25}{16}$

61. 1

$$\begin{aligned} \cos(\alpha + \beta) = \frac{4}{5} &\quad \Rightarrow \tan(\alpha + \beta) = \frac{3}{4} \\ \sin(\alpha - \beta) = \frac{5}{13} &\quad \Rightarrow \tan(\alpha - \beta) = \frac{5}{12} \\ \tan 2\alpha = \tan(\alpha + \beta + \alpha - \beta) &= \frac{\frac{3}{4} + \frac{5}{12}}{1 - \frac{3}{4} \cdot \frac{5}{12}} = \frac{56}{33} \end{aligned}$$

62. Let S be a non-empty subset of \mathbb{R} . Consider the following statement:

P: There is a rational number $x \in S$ such that $x > 0$.

Which of the following statements is the negation of the statement P ?

- (1) There is no rational number $x \in S$ such that $x \leq 0$
 (2) Every rational number $x \in S$ satisfies $x \leq 0$

- (3) $x \in S$ and $x \leq 0 \Rightarrow x$ is not rational
 (4) There is a rational number $x \in S$ such that $x \leq 0$
 62. **2**

P: there is a rational number $x \in S$ such that $x > 0$
 $\sim P$: Every rational number $x \in S$ satisfies $x \leq 0$

63. Let $\vec{a} = \hat{j} - \hat{k}$ and $\vec{c} = \hat{i} - \hat{j} - \hat{k}$. Then vector \vec{b} satisfying $\vec{a} \times \vec{b} + \vec{c} = \vec{0}$ and $\vec{a} \cdot \vec{b} = 3$ is
 (1) $2\hat{i} - \hat{j} + 2\hat{k}$ (2) $\hat{i} - \hat{j} - 2\hat{k}$ (3) $\hat{i} + \hat{j} - 2\hat{k}$ (4) $-\hat{i} + \hat{j} - 2\hat{k}$

63. **4**
 $\vec{c} = \vec{b} \times \vec{a}$
 $\Rightarrow \vec{b} \cdot \vec{c} = 0$
 $\Rightarrow (b_1\hat{i} + b_2\hat{j} + b_3\hat{k}) \cdot (\hat{i} - \hat{j} - \hat{k}) = 0$
 $b_1 - b_2 - b_3 = 0$
 and $\vec{a} \cdot \vec{b} = 3$
 $\Rightarrow b_2 - b_3 = 3$
 $b_1 = b_2 + b_3 = 3 + 2b_3$
 $\vec{b} = (3 + 2b_3)\hat{i} + (3 + b_3)\hat{j} + b_3\hat{k}$.

64. The equation of the tangent to the curve $y = x + \frac{4}{x^2}$, that is parallel to the x-axis, is
 (1) $y = 1$ (2) $y = 2$ (3) $y = 3$ (4) $y = 0$

64. **3**
 Parallel to x-axis $\Rightarrow \frac{dy}{dx} = 0 \Rightarrow 1 - \frac{8}{x^3} = 0$
 $\Rightarrow x = 2 \Rightarrow y = 3$
 Equation of tangent is $y - 3 = 0(x - 2) \Rightarrow y - 3 = 0$

65. Solution of the differential equation $\cos x \, dy = y(\sin x - y) \, dx$, $0 < x < \frac{\pi}{2}$ is
 (1) $y \sec x = \tan x + c$ (2) $y \tan x = \sec x + c$ (3) $\tan x = (\sec x + c)y$ (4) $\sec x = (\tan x + c)y$

65. **4**
 $\cos x \, dy = y(\sin x - y) \, dx$
 $\frac{dy}{dx} = y \tan x - y^2 \sec x$
 $\frac{1}{y^2} \frac{dy}{dx} - \frac{1}{y} \tan x = -\sec x$
 Let $\frac{1}{y} = t$
 $-\frac{1}{y^2} \frac{dy}{dx} = \frac{dt}{dx}$
 $-\frac{dy}{dx} - t \tan x = -\sec x \Rightarrow \frac{dt}{dx} + (\tan x) t = \sec x$
 I.F. = $e^{\int \tan x \, dx} = \sec x$
 Solution is $t(\text{I.F.}) = \int (\text{I.F.}) \sec x \, dx$

$$\frac{1}{y} \sec x = \tan x + c$$

66. The area bounded by the curves $y = \cos x$ and $y = \sin x$ between the ordinates $x = 0$ and $x = \frac{3\pi}{2}$ is
 (1) $4\sqrt{2} + 2$ (2) $4\sqrt{2} - 1$ (3) $4\sqrt{2} + 1$ (4) $4\sqrt{2} - 2$

66. **4**

$$\int_0^{\frac{\pi}{4}} (\cos x - \sin x) dx + \int_{\frac{\pi}{4}}^{\frac{5\pi}{4}} (\sin x - \cos x) dx + \int_{\frac{5\pi}{4}}^{\frac{3\pi}{2}} (\cos x - \sin x) dx = 4\sqrt{2} - 2$$

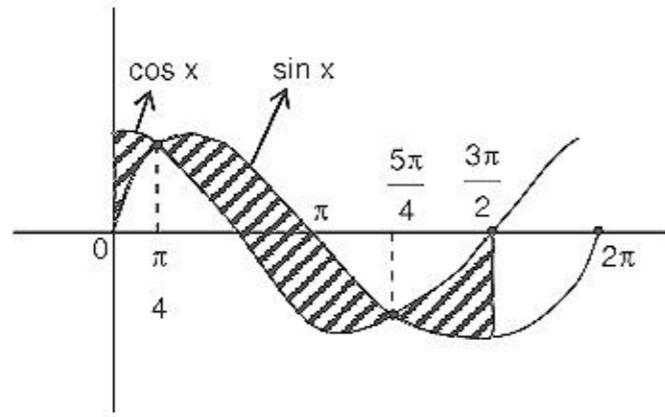

67. If two tangents drawn from a point P to the parabola $y^2 = 4x$ are at right angles, then the locus of P is
 (1) $2x + 1 = 0$ (2) $x = -1$ (3) $2x - 1 = 0$ (4) $x = 1$

67. **2**

The locus of perpendicular tangents is directrix
 i.e. $x = -a$; $x = -1$

68. If the vectors $\vec{a} = \hat{i} - \hat{j} + 2\hat{k}$, $\vec{b} = 2\hat{i} + 4\hat{j} + \hat{k}$ and $\vec{c} = \lambda\hat{i} + \hat{j} + \mu\hat{k}$ are mutually orthogonal, then $(\lambda, \mu) =$
 (1) $(2, -3)$ (2) $(-2, 3)$ (3) $(3, -2)$ (4) $(-3, 2)$

68. **4**

$$\vec{a} \cdot \vec{b} = 0, \quad \vec{b} \cdot \vec{c} = 0, \quad \vec{c} \cdot \vec{a} = 0$$

$$\Rightarrow 2\lambda + 4 + \mu = 0 \quad \lambda - 1 + 2\mu = 0$$

Solving we get: $\lambda = -3, \mu = 2$

69. Consider the following relations:

$R = \{(x, y) \mid x, y \text{ are real numbers and } x = wy \text{ for some rational number } w\};$

$S = \left\{ \left(\frac{m}{n}, \frac{p}{q} \right) \mid m, n, p \text{ and } q \text{ are integers such that } n, q \neq 0 \text{ and } qm = pn \right\}$. Then

- (1) neither R nor S is an equivalence relation
 (2) S is an equivalence relation but R is not an equivalence relation
 (3) R and S both are equivalence relations
 (4) R is an equivalence relation but S is not an equivalence relation

69. **2**

xRy need not implies yRx

$$S: \frac{m}{n} s \frac{p}{q} \Leftrightarrow qm = pn$$

$$\frac{m}{n} s \frac{m}{n} \text{ reflexive}$$

$$\frac{m}{n} S \frac{p}{q} \Rightarrow \frac{p}{q} S \frac{m}{n} \text{ symmetric}$$

$$\frac{m}{n} S \frac{p}{q}, \frac{p}{q} S \frac{r}{s} \Rightarrow qm = pn, ps = rq \Rightarrow ms = rn \text{ transitive.}$$

S is an equivalence relation.

70. Let $f: \mathbb{R} \rightarrow \mathbb{R}$ be defined by $f(x) = \begin{cases} k - 2x, & \text{if } x \leq -1 \\ 2x + 3, & \text{if } x > -1 \end{cases}$. If f has a local minimum at $x = -1$, then a possible value of k is
- (1) 0 (2) $-\frac{1}{2}$ (3) -1 (4) 1

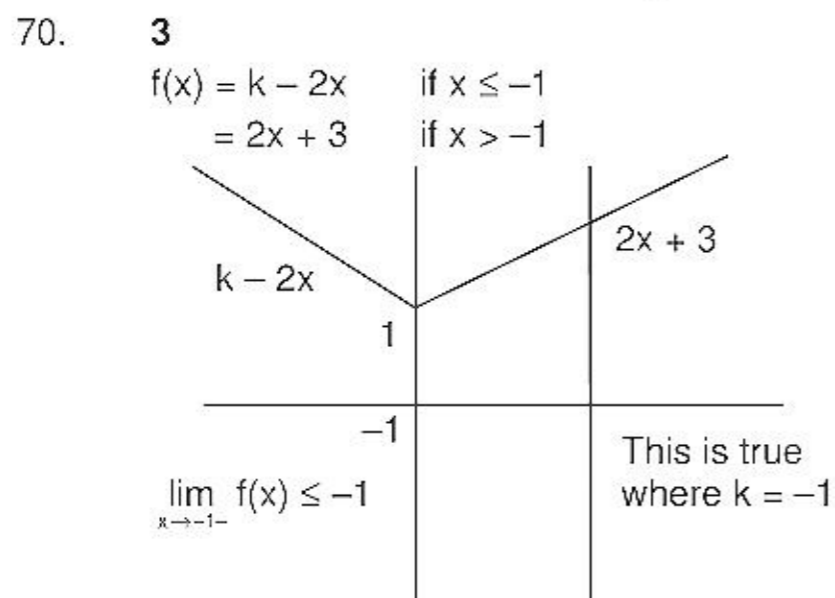

71. The number of 3×3 non-singular matrices, with four entries as 1 and all other entries as 0, is
- (1) 5 (2) 6 (3) at least 7 (4) less than 4

71. **3**

First row with exactly one zero; total number of cases = 6
 First row 2 zeros we get more cases
 Total we get more than 7.

Directions: Questions Number 72 to 76 are Assertion – Reason type questions. Each of these questions contains two statements.

Statement-1: (Assertion) and Statement-2: (Reason)

Each of these questions also has four alternative choices, only one of which is the correct answer. You have to select the correct choice.

72. Four numbers are chosen at random (without replacement) from the set $\{1, 2, 3, \dots, 20\}$.
- Statement-1:** The probability that the chosen numbers when arranged in some order will form an AP is $\frac{1}{85}$.
- Statement-2:** If the four chosen numbers form an AP, then the set of all possible values of common difference is $\{\pm 1, \pm 2, \pm 3, \pm 4, \pm 5\}$.
- (1) Statement-1 is true, Statement-2 is true; Statement-2 is not the correct explanation for Statement-1
 (2) Statement-1 is true, Statement-2 is false
 (3) Statement-1 is false, Statement-2 is true
 (4) Statement-1 is true, Statement-2 is true; Statement-2 is the correct explanation for Statement-1
72. **2**

$$N(S) = {}^{20}C_4$$

Statement-1: common difference is 1; total number of cases = 17
 common difference is 2; total number of cases = 14
 common difference is 3; total number of cases = 11
 common difference is 4; total number of cases = 8
 common difference is 5; total number of cases = 5
 common difference is 6; total number of cases = 2

$$\text{Prob.} = \frac{17+14+11+8+5+2}{{}^{20}C_4} = \frac{1}{85}$$

73. **Statement-1:** The point A(3, 1, 6) is the mirror image of the point B(1, 3, 4) in the plane $x - y + z = 5$.
Statement-2: The plane $x - y + z = 5$ bisects the line segment joining A(3, 1, 6) and B(1, 3, 4).
 (1) Statement-1 is true, Statement-2 is true; Statement-2 is not the correct explanation for Statement-1
 (2) Statement-1 is true, Statement-2 is false
 (3) Statement-1 is false, Statement-2 is true
 (4) Statement-1 is true, Statement-2 is true; Statement-2 is the correct explanation for Statement-1

73. **1**
 A(3, 1, 6); B = (1, 3, 4)
 Mid-point of AB = (2, 2, 5) lies on the plane.
 and d.r's of AB = (2, -2, 2)
 d.r's Of normal to plane = (1, -1, 1).
 AB is perpendicular bisector
 \therefore A is image of B
 Statement-2 is correct but it is not correct explanation.

74. Let $S_1 = \sum_{j=1}^{10} j(j-1) {}^{10}C_j$, $S_2 = \sum_{j=1}^{10} j {}^{10}C_j$ and $S_3 = \sum_{j=1}^{10} j^2 {}^{10}C_j$.
Statement-1: $S_3 = 55 \times 2^9$
Statement-2: $S_1 = 90 \times 2^8$ and $S_2 = 10 \times 2^8$.
 (1) Statement-1 is true, Statement-2 is true; Statement-2 is not the correct explanation for Statement-1
 (2) Statement-1 is true, Statement-2 is false
 (3) Statement-1 is false, Statement-2 is true
 (4) Statement-1 is true, Statement-2 is true; Statement-2 is the correct explanation for Statement-1

74. **2**

$$S_1 = \sum_{j=1}^{10} j(j-1) \frac{10!}{j(j-1)(j-2)!(10-j)!} = 90 \sum_{j=2}^{10} \frac{8!}{(j-2)!(8-(j-2))!} = 90 \cdot 2^8$$

$$S_2 = \sum_{j=1}^{10} j \frac{10!}{j(j-1)!(9-(j-1))!} = 10 \sum_{j=1}^{10} \frac{9!}{(j-1)!(9-(j-1))!} = 10 \cdot 2^9$$

$$S_3 = \sum_{j=1}^{10} [j(j-1) + j] \frac{10!}{j!(10-j)!} = \sum_{j=1}^{10} j(j-1) {}^{10}C_j + \sum_{j=1}^{10} j {}^{10}C_j = 90 \cdot 2^8 + 10 \cdot 2^9$$

$$= 90 \cdot 2^8 + 20 \cdot 2^8 = 110 \cdot 2^8 = 55 \cdot 2^9$$

75. Let A be a 2×2 matrix with non-zero entries and let $A^2 = I$, where I is 2×2 identity matrix. Define $\text{Tr}(A)$ = sum of diagonal elements of A and $|A|$ = determinant of matrix A.
Statement-1: $\text{Tr}(A) = 0$
Statement-2: $|A| = 1$
 (1) Statement-1 is true, Statement-2 is true; Statement-2 is not the correct explanation for Statement-1
 (2) Statement-1 is true, Statement-2 is false

- (3) Statement-1 is false, Statement-2 is true
 (4) Statement-1 is true, Statement-2 is true; Statement-2 is the correct explanation for Statement-1

75.

2

$$\text{Let } A = \begin{pmatrix} a & b \\ c & d \end{pmatrix}, abcd \neq 0$$

$$A^2 = \begin{pmatrix} a & b \\ c & d \end{pmatrix} \cdot \begin{pmatrix} a & b \\ c & d \end{pmatrix}$$

$$\Rightarrow A^2 = \begin{pmatrix} a^2 + bc & ab + bd \\ ac + cd & bc + d^2 \end{pmatrix}$$

$$\Rightarrow a^2 + bc = 1, bc + d^2 = 1$$

$$ab + bd = ac + cd = 0$$

$$c \neq 0 \text{ and } b \neq 0 \Rightarrow a + d = 0$$

$$\text{Trace } A = a + d = 0$$

$$|A| = ad - bc = -a^2 - bc = -1.$$

76. Let $f: \mathbb{R} \rightarrow \mathbb{R}$ be a continuous function defined by $f(x) = \frac{1}{e^x + 2e^{-x}}$.

Statement-1: $f(c) = \frac{1}{3}$, for some $c \in \mathbb{R}$.

Statement-2: $0 < f(x) \leq \frac{1}{2\sqrt{2}}$, for all $x \in \mathbb{R}$

- (1) Statement-1 is true, Statement-2 is true; Statement-2 is not the correct explanation for Statement-1
 (2) Statement-1 is true, Statement-2 is false
 (3) Statement-1 is false, Statement-2 is true
 (4) Statement-1 is true, Statement-2 is true; Statement-2 is the correct explanation for Statement-1

76.

4

$$f(x) = \frac{1}{e^x + 2e^{-x}} = \frac{e^x}{e^{2x} + 2}$$

$$f'(x) = \frac{(e^{2x} + 2)e^x - 2e^{2x} \cdot e^x}{(e^{2x} + 2)^2}$$

$$f'(x) = 0 \Rightarrow e^{2x} + 2 = 2e^{2x}$$

$$e^{2x} = 2 \Rightarrow e^x = \sqrt{2}$$

$$\text{maximum } f(x) = \frac{\sqrt{2}}{4} = \frac{1}{2\sqrt{2}}$$

$$0 < f(x) \leq \frac{1}{2\sqrt{2}} \quad \forall x \in \mathbb{R}$$

$$\text{Since } 0 < \frac{1}{3} < \frac{1}{2\sqrt{2}} \Rightarrow \text{for some } c \in \mathbb{R}$$

$$f(c) = \frac{1}{3}$$

77. For a regular polygon, let r and R be the radii of the inscribed and the circumscribed circles. A false statement among the following is

- (1) There is a regular polygon with $\frac{r}{R} = \frac{1}{\sqrt{2}}$ (2) There is a regular polygon with $\frac{r}{R} = \frac{2}{3}$

- (3) There is a regular polygon with $\frac{r}{R} = \frac{\sqrt{3}}{2}$ (4) There is a regular polygon with $\frac{r}{R} = \frac{1}{2}$

77. **2**

$$r = \frac{a}{2} \cot \frac{\pi}{n}$$

'a' is side of polygon.

$$R = \frac{a}{2} \operatorname{cosec} \frac{\pi}{n}$$

$$\frac{r}{R} = \frac{\cot \frac{\pi}{n}}{\operatorname{cosec} \frac{\pi}{n}} = \cos \frac{\pi}{n}$$

$$\cos \frac{\pi}{n} \neq \frac{2}{3} \text{ for any } n \in \mathbb{N}.$$

78. If α and β are the roots of the equation $x^2 - x + 1 = 0$, then $\alpha^{2009} + \beta^{2009} =$
 (1) -1 (2) 1 (3) 2 (4) -2

78. **2**

$$x^2 - x + 1 = 0 \quad \Rightarrow x = \frac{1 \pm \sqrt{1-4}}{2}$$

$$x = \frac{1 \pm \sqrt{3}i}{2}$$

$$\alpha = \frac{1}{2} + i \frac{\sqrt{3}}{2}, \quad \beta = \frac{1}{2} - i \frac{\sqrt{3}}{2}$$

$$\alpha = \cos \frac{\pi}{3} + i \sin \frac{\pi}{3}, \quad \beta = \cos \frac{\pi}{3} - i \sin \frac{\pi}{3}$$

$$\alpha^{2009} + \beta^{2009} = 2 \cos 2009 \left(\frac{\pi}{3} \right)$$

$$= 2 \cos \left[668\pi + \pi + \frac{2\pi}{3} \right] = 2 \cos \left(\pi + \frac{2\pi}{3} \right)$$

$$= -2 \cos \frac{2\pi}{3} = -2 \left(-\frac{1}{2} \right) = 1$$

79. The number of complex numbers z such that $|z - 1| = |z + 1| = |z - i|$ equals
 (1) 1 (2) 2 (3) ∞ (4) 0

79. **1**

Let $z = x + iy$

$$|z - 1| = |z + 1| \quad \Rightarrow \operatorname{Re} z = 0 \quad \Rightarrow x = 0$$

$$|z - 1| = |z - i| \quad \Rightarrow x = y$$

$$|z + 1| = |z - i| \quad \Rightarrow y = -x$$

Only (0, 0) will satisfy all conditions.

\Rightarrow Number of complex number $z = 1$

80. A line AB in three-dimensional space makes angles 45° and 120° with the positive x-axis and the positive y-axis respectively. If AB makes an acute angle θ with the positive z-axis, then θ equals

- (1) 45° (2) 60° (3) 75° (4) 30°

80. **2**

$$l = \cos 45^\circ = \frac{1}{\sqrt{2}}$$

$$m = \cos 120^\circ = -\frac{1}{2}$$

$$n = \cos \theta$$

where θ is the angle which line makes with positive z-axis.

$$\text{Now } l^2 + m^2 + n^2 = 1$$

$$\Rightarrow \frac{1}{2} + \frac{1}{4} + \cos^2 \theta = 1$$

$$\cos^2 \theta = \frac{1}{4}$$

$$\Rightarrow \cos \theta = \frac{1}{2} \quad (\theta \text{ Being acute})$$

$$\Rightarrow \theta = \frac{\pi}{3}$$

81. The line L given by $\frac{x}{5} + \frac{y}{b} = 1$ passes through the point (13, 32). The line K is parallel to L and has

the equation $\frac{x}{c} + \frac{y}{3} = 1$. Then the distance between L and K is

- (1) $\sqrt{17}$ (2) $\frac{17}{\sqrt{15}}$ (3) $\frac{23}{\sqrt{17}}$ (4) $\frac{23}{\sqrt{15}}$

81. **3**

$$\text{Slope of line L} = -\frac{b}{5}$$

$$\text{Slope of line K} = -\frac{3}{c}$$

Line L is parallel to line k.

$$\Rightarrow \frac{b}{5} = \frac{3}{c} \quad \Rightarrow bc = 15$$

(13, 32) is a point on L.

$$\Rightarrow \frac{13}{5} + \frac{32}{b} = 1 \quad \Rightarrow \frac{32}{b} = -\frac{8}{5}$$

$$\Rightarrow b = -20 \quad \Rightarrow c = -\frac{3}{4}$$

Equation of K: $y - 4x = 3$

$$\text{Distance between L and K} = \frac{|52 - 32 + 3|}{\sqrt{17}} = \frac{23}{\sqrt{17}}$$

82. A person is to count 4500 currency notes. Let a_n denote the number of notes he counts in the n^{th} minute. If $a_1 = a_2 = \dots = a_{10} = 150$ and a_{10}, a_{11}, \dots are in A.P. with common difference -2 , then the time taken by him to count all notes is

- (1) 34 minutes (2) 125 minutes (3) 135 minutes (4) 24 minutes

82. **1**

Till 10^{th} minute number of counted notes = 1500

$$3000 = \frac{n}{2} [2 \times 148 + (n-1)(-2)] = n[148 - n + 1]$$

$$n^2 - 149n + 3000 = 0$$

$$n = 125, 24$$

$n = 125$ is not possible.
Total time = $24 + 10 = 34$ minutes.

83. Let $f: \mathbb{R} \rightarrow \mathbb{R}$ be a positive increasing function with $\lim_{x \rightarrow \infty} \frac{f(3x)}{f(x)} = 1$. Then $\lim_{x \rightarrow \infty} \frac{f(2x)}{f(x)} =$
- (1) $\frac{2}{3}$ (2) $\frac{3}{2}$ (3) 3 (4) 1

83. **4**

$f(x)$ is a positive increasing function
 $\Rightarrow 0 < f(x) < f(2x) < f(3x)$
 $\Rightarrow 0 < 1 < \frac{f(2x)}{f(x)} < \frac{f(3x)}{f(x)}$
 $\Rightarrow \lim_{x \rightarrow \infty} 1 \leq \lim_{x \rightarrow \infty} \frac{f(2x)}{f(x)} \leq \lim_{x \rightarrow \infty} \frac{f(3x)}{f(x)}$
 By sandwich theorem.
 $\Rightarrow \lim_{x \rightarrow \infty} \frac{f(2x)}{f(x)} = 1$

84. Let $p(x)$ be a function defined on \mathbb{R} such that $p'(x) = p'(1 - x)$, for all $x \in [0, 1]$, $p(0) = 1$ and $p(1) = 41$.
 Then $\int_0^1 p(x) dx$ equals
- (1) 21 (2) 41 (3) 42 (4) $\sqrt{41}$

84. **1**

$p'(x) = p'(1 - x)$
 $\Rightarrow p(x) = -p(1 - x) + c$
 at $x = 0$
 $p(0) = -p(1) + c \Rightarrow 42 = c$
 now $p(x) = -p(1 - x) + 42$
 $\Rightarrow p(x) + p(1 - x) = 42$
 $I = \int_0^1 p(x) dx = \int_0^1 p(1 - x) dx$
 $2I = \int_0^1 (42) dx \Rightarrow I = 21$.

85. Let $f: (-1, 1) \rightarrow \mathbb{R}$ be a differentiable function with $f(0) = -1$ and $f'(0) = 1$. Let $g(x) = [f(2f(x) + 2)]^2$.
 Then $g'(0) =$
- (1) -4 (2) 0 (3) -2 (4) 4

85. **1**

$g'(x) = 2(f(2f(x) + 2)) \left(\frac{d}{dx} (f(2f(x) + 2)) \right) = 2f(2f(x) + 2) f'(2f(x) + 2) \cdot (2f'(x))$
 $\Rightarrow g'(0) = 2f(2f(0) + 2) \cdot f'(2f(0) + 2) \cdot 2(f'(0)) = 4f(0) f'(0)$
 $= 4(-1) (1) = -4$

86. There are two urns. Urn A has 3 distinct red balls and urn B has 9 distinct blue balls. From each urn two balls are taken out at random and then transferred to the other. The number of ways in which this can be done is

(1) 36 (2) 66 (3) 108 (4) 3

86. **3**

$$\begin{aligned} \text{Total number of ways} &= {}^3C_2 \times {}^9C_2 \\ &= 3 \times \frac{9 \times 8}{2} = 3 \times 36 = 108 \end{aligned}$$

87. Consider the system of linear equations:

$$x_1 + 2x_2 + x_3 = 3$$

$$2x_1 + 3x_2 + x_3 = 3$$

$$3x_1 + 5x_2 + 2x_3 = 1$$

The system has

(1) exactly 3 solutions

(2) a unique solution

(3) no solution

(4) infinite number of solutions

87. **3**

$$D = \begin{vmatrix} 1 & 2 & 1 \\ 2 & 3 & 1 \\ 3 & 5 & 2 \end{vmatrix} = 0$$

$$D_1 = \begin{vmatrix} 3 & 2 & 1 \\ 3 & 3 & 1 \\ 1 & 5 & 2 \end{vmatrix} \neq 0$$

⇒ Given system, does not have any solution.

⇒ No solution.

88. An urn contains nine balls of which three are red, four are blue and two are green. Three balls are drawn at random without replacement from the urn. The probability that the three balls have different colour is

(1) $\frac{2}{7}$ (2) $\frac{1}{21}$ (3) $\frac{2}{23}$ (4) $\frac{1}{3}$

88. **1**

$$n(S) = {}^9C_3$$

$$n(E) = {}^3C_1 \times {}^4C_1 \times {}^2C_1$$

$$\text{Probability} = \frac{3 \times 4 \times 2}{{}^9C_3} = \frac{24 \times 3!}{9!} \times 6! = \frac{24 \times 6}{9 \times 8 \times 7} = \frac{2}{7}$$

89. For two data sets, each of size 5, the variances are given to be 4 and 5 and the corresponding means are given to be 2 and 4, respectively. The variance of the combined data set is

(1) $\frac{11}{2}$ (2) 6 (3) $\frac{13}{2}$ (4) $\frac{5}{2}$

89. **1**

$$\sigma_x^2 = 4$$

$$\sigma_y^2 = 5$$

$$\bar{x} = 2$$

$$\bar{y} = 4$$

$$\frac{\sum x_i}{5} = 2 \quad \sum x_i = 10; \sum y_i = 20$$

$$\sigma_x^2 = \left(\frac{1}{2} \sum x_i^2 \right) - (\bar{x})^2 = \frac{1}{5} (\sum y_i^2) - 16$$

$$\sum x_i^2 = 40$$

$$\sum y_i^2 = 105$$

$$\sigma_z^2 = \frac{1}{10} (\sum x_i^2 + \sum y_i^2) - \left(\frac{\bar{x} + \bar{y}}{2} \right)^2 = \frac{1}{10} (40 + 105) - 9 = \frac{145 - 90}{10} = \frac{55}{10} = \frac{11}{2}$$

90. The circle $x^2 + y^2 = 4x + 8y + 5$ intersects the line $3x - 4y = m$ at two distinct points if
 (1) $-35 < m < 15$ (2) $15 < m < 65$ (3) $35 < m < 85$ (4) $-85 < m < -35$

90.

1

$$\text{Circle } x^2 + y^2 - 4x - 8y - 5 = 0$$

$$\text{Centre} = (2, 4), \text{Radius} = \sqrt{4 + 16 + 5} = 5$$

If circle is intersecting line $3x - 4y = m$

at two distinct points.

\Rightarrow length of perpendicular from centre $<$ radius

$$\Rightarrow \frac{|6 - 16 - m|}{5} < 5$$

$$\Rightarrow |10 + m| < 25$$

$$\Rightarrow -25 < m + 10 < 25$$

$$\Rightarrow -35 < m < 15.$$

* * *

READ THE FOLLOWING INSTRUCTIONS CAREFULLY:

1. The candidates should fill in the required particulars on the Test Booklet and Answer Sheet (**Side-1**) with **Blue/Black Ball Point Pen**.
2. For writing/marketing particulars on **Side-2** of the Answer Sheet, use **Blue/Black Ball Point Pen only**.
3. The candidates should not write their Roll Numbers anywhere else (except in the specified space) on the Test Booklet/Answer Sheet.
4. Out of the four options given for each question, only one option is the correct answer.
5. For each **incorrect response**, **one-fourth** (1/4) of the total marks allotted to the question would be deducted from the total score. **No deduction** from the total score, however, will be made **if no response** is indicated for an item in the Answer Sheet.
6. Handle the Test Booklet and Answer Sheet with care, as under no circumstances (except for discrepancy in Test Booklet Code and Answer Sheet Code), will another set be provided.
7. The candidates are not allowed to do any rough work or writing work on the Answer Sheet. All calculations/writing work are to be done in the space provided for this purpose in the Test Booklet itself, marked 'Space for Rough Work'. This space is given at the bottom of each page and in 4 pages (Pages 20 - 23) at the end of the booklet.
8. On completion of the test, the candidates must hand over the Answer Sheet to the Invigilator on duty in the Room/Hall. **However, the candidates are allowed to take away this Test Booklet with them.**
9. Each candidate must show on demand his/her Admit Card to the Invigilator.
10. No candidate, without special permission of the Superintendent or Invigilator, should leave his/her seat.
11. The candidates should not leave the Examination Hall without handing over their Answer Sheet to the Invigilator on duty and sign the Attendance Sheet again. Cases where a candidate has not signed the Attendance Sheet a second time will be deemed not to have handed over the Answer Sheet and dealt with as an unfair means case. **The candidates are also required to put their left hand THUMB impression in the space provided in the Attendance Sheet.**
12. Use of Electronic/Manual Calculator and any Electronic Item like mobile phone, pager etc. is prohibited.
13. The candidates are governed by all Rules and Regulations of the Board with regard to their conduct in the Examination Hall. All cases of unfair means will be dealt with as per Rules and Regulations of the Board.
14. No part of the Test Booklet and Answer Sheet shall be detached under any circumstances.
15. **Candidates are not allowed to carry any textual material, printed or written, bits of papers, pager, mobile phone, electronic device or any other material except the Admit Card inside the examination hall/room.**