

National Testing Agency

Question Paper Name: Paper I EHG 12th April 2019 Shift 2
Subject Name: Paper I EHG
Creation Date: 2019-04-12 19:35:39
Duration: 180
Total Marks: 360
Display Marks: Yes

Paper I

Group Number : 1
Group Id : 416529161
Group Maximum Duration : 0
Group Minimum Duration : 180
Revisit allowed for view? : No
Revisit allowed for edit? : No
Break time: 0
Group Marks: 360

Physics

Section Id : 416529277
Section Number : 1
Section type : Online
Mandatory or Optional: Mandatory
Number of Questions: 30
Number of Questions to be attempted: 30
Section Marks: 120
Display Number Panel: Yes
Group All Questions: No

Sub-Section Number: 1
Sub-Section Id: 416529417
Question Shuffling Allowed : Yes

Question Number : 1 Question Type : MCQ Option Shuffling : Yes Display Question Number : Yes Single Line Question Option : No Option Orientation : Vertical

Correct Marks : 4 Wrong Marks : 1

The number density of molecules of a gas depends on their distance r from the origin as, $n(r) = n_0 e^{-\alpha r^4}$. Then the total number of molecules is proportional to :

Options :

1. $n_0 \alpha^{-3}$

2. $\sqrt{n_0} \alpha^{1/2}$

3. $n_0 \alpha^{-3/4}$

4. $n_0 \alpha^{1/4}$

Question Number : 1 Question Type : MCQ Option Shuffling : Yes Display Question Number : Yes Single Line Question Option : No Option Orientation : Vertical

Correct Marks : 4 Wrong Marks : 1

एक गैस के अणुओं का संख्या घनत्व मूल बिन्दु से दूरी r पर निम्न ढंग से निर्भर है, $n(r) = n_0 e^{-\alpha r^4}$ । तो इस गैस के अणुओं की कुल संख्या किसके समानुपाती होगी ?

Options :

1. $n_0 \alpha^{-3}$

2. $\sqrt{n_0} \alpha^{1/2}$

3. $n_0 \alpha^{-3/4}$

4. $n_0 \alpha^{1/4}$

Question Number : 1 Question Type : MCQ Option Shuffling : Yes Display Question Number : Yes Single Line Question Option : No Option Orientation : Vertical

Correct Marks : 4 Wrong Marks : 1

वायु अणुओं की संख्या घनत्व, उद्गमथी तेमना अंतर पर $n(r) = n_0 e^{-\alpha r^4}$ मुळ आधार राखे छे. तो कुल अणुओं की संख्या _____ ना समप्रमाणां छे.

Options :

1. $n_0 \alpha^{-3}$

2. $\sqrt{n_0} \alpha^{1/2}$

3. $n_0 \alpha^{-3/4}$

4. $n_0 \alpha^{1/4}$

Question Number : 2 Question Type : MCQ Option Shuffling : Yes Display Question Number : Yes Single Line Question Option : No Option Orientation : Vertical

Correct Marks : 4 Wrong Marks : 1

A particle is moving with speed $v = b\sqrt{x}$ along positive x -axis. Calculate the speed of the particle at time $t = \tau$ (assume that the particle is at origin at $t = 0$).

Options :

1. $\frac{b^2\tau}{4}$

2. $\frac{b^2\tau}{\sqrt{2}}$

3. $\frac{b^2\tau}{2}$

4. $b^2\tau$

Question Number : 2 Question Type : MCQ Option Shuffling : Yes Display Question Number : Yes Single Line Question Option : No Option Orientation : Vertical

Correct Marks : 4 Wrong Marks : 1

एक कण चाल $v = b\sqrt{x}$ से धनात्मक x -अक्ष की दिशा में चल रहा है। समय $t = \tau$ पर कण की चाल होगी :
(माना कि $t = 0$ पर कण मूल बिन्दु पर है।)

Options :

1. $\frac{b^2\tau}{4}$

2. $\frac{b^2\tau}{\sqrt{2}}$

3. $\frac{b^2\tau}{2}$

4. $b^2\tau$

Question Number : 2 Question Type : MCQ Option Shuffling : Yes Display Question Number : Yes Single Line Question Option : No Option Orientation : Vertical

Correct Marks : 4 Wrong Marks : 1

એક કણ $v = b\sqrt{x}$ જેટલા વેગથી ધન x -અક્ષની દિશામાં ગતિ કરે છે. કણનો $t = \tau$ સમયે વેગ ગણો (ધારો કે કણ $t = 0$ સમયે ઉગમબિંદુ પર છે)

Options :

1. $\frac{b^2\tau}{4}$

2. $\frac{b^2\tau}{\sqrt{2}}$

3. $\frac{b^2\tau}{2}$

4. $b^2\tau$

Question Number : 3 Question Type : MCQ Option Shuffling : Yes Display Question Number : Yes Single Line Question Option : No Option Orientation : Vertical

Correct Marks : 4 Wrong Marks : 1

Two particles are projected from the same point with the same speed u such that they have the same range R , but different maximum heights, h_1 and h_2 . Which of the following is correct ?

Options :

1. $R^2 = 16 h_1 h_2$

2. $R^2 = 4 h_1 h_2$

3. $R^2 = 2 h_1 h_2$

4. $R^2 = h_1 h_2$

Question Number : 3 Question Type : MCQ Option Shuffling : Yes Display Question Number : Yes Single Line Question Option : No Option Orientation : Vertical

Correct Marks : 4 Wrong Marks : 1

दो कणों को एक ही बिन्दु से एक ही चाल u से प्रक्षेपित किया जाता है जिससे उनकी परास R बराबर हैं किन्तु अधिकतम ऊँचाइयाँ h_1 तथा h_2 भिन्न हैं। निम्न में सत्य कथन चुनिये।

Options :

1. $R^2 = 16 h_1 h_2$

2. $R^2 = 4 h_1 h_2$

3. $R^2 = 2 h_1 h_2$

4. $R^2 = h_1 h_2$

Question Number : 3 Question Type : MCQ Option Shuffling : Yes Display Question Number : Yes Single Line Question Option : No Option Orientation : Vertical

Correct Marks : 4 Wrong Marks : 1

બે કણોને સમાન બિંદુથી સમાન ઝડપ u સાથે એવી રીતે પ્રક્ષિપ્ત કરવામાં આવે છે કે જેથી તેમની અવધિ R સમાન હોય પરંતુ મહત્તમ ઉંચાઈ h_1 અને h_2 જેટલી જૂદી-જૂદી હોય તો નીચેનામાંથી કયું સાચું છે?

Options :

1. $R^2 = 16 h_1 h_2$

2. $R^2 = 4 h_1 h_2$

3. $R^2 = 2 h_1 h_2$

4. $R^2 = h_1 h_2$

Question Number : 4 Question Type : MCQ Option Shuffling : Yes Display Question Number : Yes Single Line Question Option : No Option Orientation : Vertical

Correct Marks : 4 Wrong Marks : 1

A block of mass 5 kg is (i) pushed in case (A) and (ii) pulled in case (B), by a force $F = 20$ N, making an angle of 30° with the horizontal, as shown in the figures. The coefficient of friction between the block and floor is $\mu = 0.2$. The difference between the accelerations of the block, in case (B) and case (A) will be : ($g = 10 \text{ ms}^{-2}$)

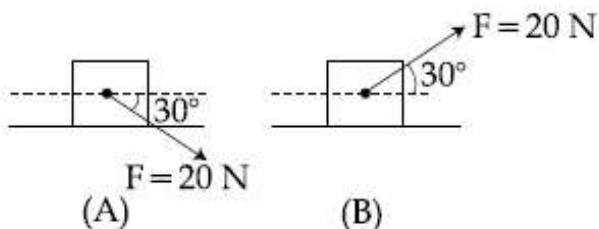

Options :

1. 0 ms^{-2}
2. 3.2 ms^{-2}
3. 0.4 ms^{-2}
4. 0.8 ms^{-2}

Question Number : 4 Question Type : MCQ Option Shuffling : Yes Display Question Number : Yes Single Line Question Option : No Option Orientation : Vertical

Correct Marks : 4 Wrong Marks : 1

5 kg के एक गुटके को क्षैतिज से 30° कोण पर बल $F = 20 \text{ N}$ से चित्रानुसार (i) दशा (A) में धकेलते हैं तथा (ii) दशा (B) में खींचते हैं। गुटके तथा समतल के बीच घर्षण गुणांक $\mu = 0.2$ है। इन दो दशाओं (A) तथा (B), में गुटके के त्वरणों के अन्तर का मान होगा : ($g = 10 \text{ ms}^{-2}$)

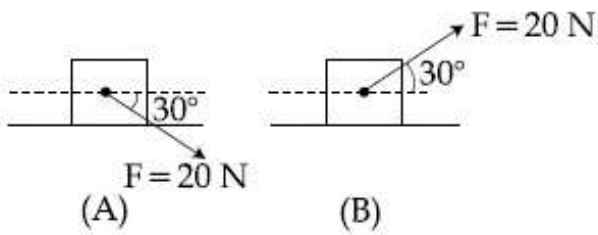

Options :

1. 0 ms^{-2}
2. 3.2 ms^{-2}
3. 0.4 ms^{-2}
4. 0.8 ms^{-2}

Question Number : 4 Question Type : MCQ Option Shuffling : Yes Display Question Number : Yes Single Line Question Option : No Option Orientation : Vertical

Correct Marks : 4 Wrong Marks : 1

આકૃતિમાં દર્શાવ્યા મુજબ, 5 kg દળવાળા એક ચોસલા ને સમક્ષિતિજ સાથે 30° ના કોણે લાગતા $F = 20$ N જેટલા બળ વડે, કિસ્સા (A) મુજબ ઘક્કો અને કિસ્સા (B) મુજબ ખેંચવામાં આવે છે. ચોસલા અને જમીન વચ્ચે ધર્ષણાંક $\mu = 0.2$ છે. કિસ્સા (B) અને કિસ્સા (A) માટે સપાટી પર ચોસલાના પ્રવેગોમાં તફાવત _____ . ($g = 10 \text{ ms}^{-2}$)

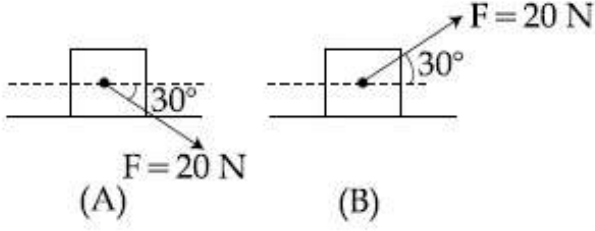

Options :

1. 0 ms^{-2}
2. 3.2 ms^{-2}
3. 0.4 ms^{-2}
4. 0.8 ms^{-2}

Question Number : 5 Question Type : MCQ Option Shuffling : Yes Display Question Number : Yes Single Line Question Option : No Option Orientation : Vertical

Correct Marks : 4 Wrong Marks : 1

A spring whose unstretched length is l has a force constant k . The spring is cut into two pieces of unstretched lengths l_1 and l_2 where, $l_1 = nl_2$ and n is an integer. The ratio k_1/k_2 of the corresponding force constants, k_1 and k_2 will be :

Options :

1. n
2. $\frac{1}{n}$
3. n^2
4. $\frac{1}{n^2}$

Question Number : 5 Question Type : MCQ Option Shuffling : Yes Display Question Number : Yes Single Line Question Option : No Option Orientation : Vertical

Correct Marks : 4 Wrong Marks : 1

एक स्प्रिंग की स्वतंत्र लम्बाई l तथा बल नियतांक k है। इसे काटकर l_1 तथा l_2 स्वतंत्र लम्बाई की दो स्प्रिंगों में बाँटते हैं। $l_1 = nl_2$ है, जहाँ n एक पूर्णांक है। इनसे सम्बद्ध बल नियतांकों k_1 तथा k_2 का अनुपात, k_1/k_2 होगा :

Options :

1. n
2. $\frac{1}{n}$
3. n^2
4. $\frac{1}{n^2}$

Question Number : 5 Question Type : MCQ Option Shuffling : Yes Display Question Number : Yes Single Line Question Option : No Option Orientation : Vertical

Correct Marks : 4 Wrong Marks : 1

એક સ્પ્રિંગ કે જેની ખેંચાણ મુક્ત સ્થિતિમાં લંબાઈ l છે તેનો બળ અચળાંક k છે. આ સ્પ્રિંગને ખેંચાણ રહિત l_1 અને l_2 લંબાઈના, જ્યાં $l_1 = nl_2$ અને n એ પૂર્ણાંક, એવા બે ભાગમાં કાપવામાં આવે છે. આનુષંગિક બળ અચળાંકો k_1 અને k_2 નો ગુણોત્તર :

Options :

1. n
2. $\frac{1}{n}$
3. n^2
4. $\frac{1}{n^2}$

Question Number : 6 Question Type : MCQ Option Shuffling : Yes Display Question Number : Yes Single Line Question Option : No Option Orientation : Vertical

Correct Marks : 4 Wrong Marks : 1

A smooth wire of length $2\pi r$ is bent into a circle and kept in a vertical plane. A bead can slide smoothly on the wire. When the circle is rotating with angular speed ω about the vertical diameter AB, as shown in figure, the bead is at rest with respect to the circular ring at position P as shown. Then the value of ω^2 is equal to :

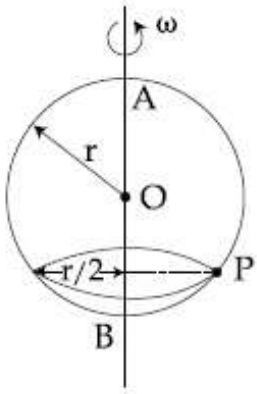

Options :

1. $2g/r$
2. $\frac{\sqrt{3}g}{2r}$
3. $(g\sqrt{3})/r$
4. $2g/(r\sqrt{3})$

Question Number : 6 Question Type : MCQ Option Shuffling : Yes Display Question Number : Yes Single Line Question Option : No Option Orientation : Vertical

Correct Marks : 4 Wrong Marks : 1

$2\pi r$ लम्बाई के एक घर्षण रहित तार को वृत्त बनाकर ऊर्ध्वाधर समतल में रखा है। एक मणिका (bead) इस तार पर फिसलती है। वृत्त को एक ऊर्ध्वाधर अक्ष AB के परितः चित्रानुसार कोणीय वेग ω से घुमाया जाता है तो वृत्त के सापेक्ष मणिका चित्रानुसार बिन्दु P पर स्थिर पायी जाती है। ω^2 का मान होगा :

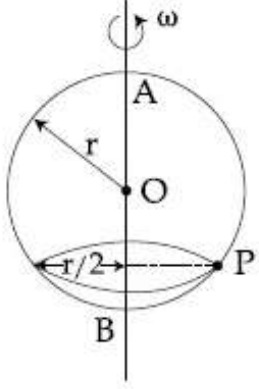

Options :

1. $2g/r$
2. $\frac{\sqrt{3}g}{2r}$
3. $(g\sqrt{3})/r$
4. $2g/(r\sqrt{3})$

Question Number : 6 Question Type : MCQ Option Shuffling : Yes Display Question Number : Yes Single Line Question Option : No Option Orientation : Vertical

Correct Marks : 4 Wrong Marks : 1

2πr લંબાઈના એક ઘર્ષણરહિત તારને વર્તુળાકાર આકારમાં વાળીને ઉર્ધ્વ સમતલમાં રાખવામાં આવેલ છે. એક મણકો તાર પર સરળતાથી સરકી સકે છે. આકૃતિમાં દર્શાવ્યા મુજબ, જ્યારે વર્તુળના AB વ્યાસને ફરતે ω જેટલી કોણીય ઝડપથી પરિભ્રમણ કરાવવામાં આવે છે, ત્યારે મણકો દર્શાવ્યા મુજબ P સ્થાને વર્તુળાકાર રિંગને સાપેક્ષે સ્થિર છે. તો ω² નું મૂલ્ય _____ ને બરાબર થશે.

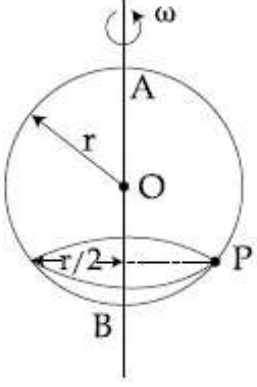

Options :

1. $2g/r$
2. $\frac{\sqrt{3}g}{2r}$
3. $(g\sqrt{3})/r$
4. $2g/(r\sqrt{3})$

Question Number : 7 Question Type : MCQ Option Shuffling : Yes Display Question Number : Yes Single Line Question Option : No Option Orientation : Vertical

Correct Marks : 4 Wrong Marks : 1

Three particles of masses 50 g, 100 g and 150 g are placed at the vertices of an equilateral triangle of side 1 m (as shown in the figure). The (x, y) coordinates of the centre of mass will be :

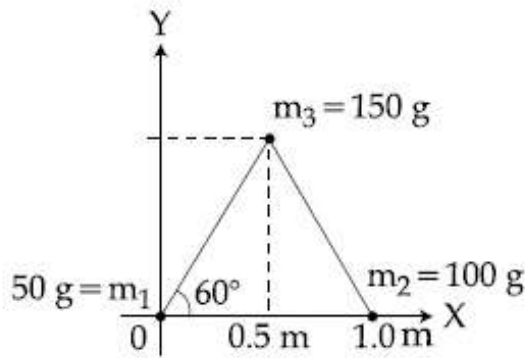

Options :

1. $\left(\frac{7}{12} \text{ m}, \frac{\sqrt{3}}{8} \text{ m}\right)$

2. $\left(\frac{7}{12} \text{ m}, \frac{\sqrt{3}}{4} \text{ m}\right)$

3. $\left(\frac{\sqrt{3}}{4} \text{ m}, \frac{5}{12} \text{ m}\right)$

4. $\left(\frac{\sqrt{3}}{8} \text{ m}, \frac{7}{12} \text{ m}\right)$

Question Number : 7 Question Type : MCQ Option Shuffling : Yes Display Question Number : Yes Single Line Question Option : No Option Orientation : Vertical

Correct Marks : 4 Wrong Marks : 1

50 g, 100 g तथा 150 g के तीन कणों को चित्रानुसार 1 m भुजा वाले एक समबाहु त्रिभुज के कोनों पर रखा है। इस निकाय के द्रव्यमान केन्द्र (x तथा y) के निर्देशांक होंगे :

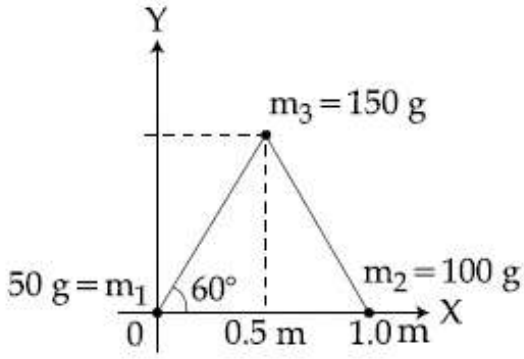

Options :

1. $\left(\frac{7}{12} \text{ m}, \frac{\sqrt{3}}{8} \text{ m}\right)$

2. $\left(\frac{7}{12} \text{ m}, \frac{\sqrt{3}}{4} \text{ m}\right)$

3. $\left(\frac{\sqrt{3}}{4} \text{ m}, \frac{5}{12} \text{ m}\right)$

4. $\left(\frac{\sqrt{3}}{8} \text{ m}, \frac{7}{12} \text{ m}\right)$

Question Number : 7 Question Type : MCQ Option Shuffling : Yes Display Question Number : Yes Single Line Question Option : No Option Orientation : Vertical

Correct Marks : 4 Wrong Marks : 1

50 g, 100 g અને 150 g દળ ધરાવતા ત્રણ કણોને 1 m લંબાઈ ધરાવતા સમબાજુ ત્રિકોણના શિરોબિંદુઓ પર મુકવામાં આવેલ છે. દ્રવ્યમાન કેન્દ્રના (x, y) યામો _____ હશે.

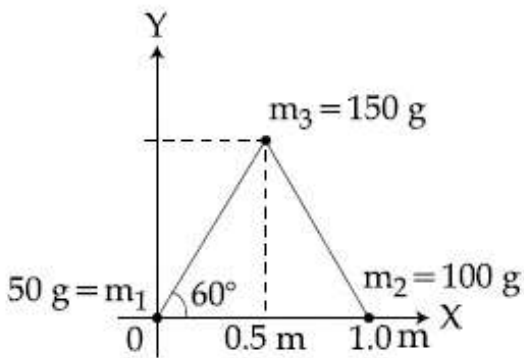

Options :

1. $\left(\frac{7}{12}m, \frac{\sqrt{3}}{8}m\right)$

2. $\left(\frac{7}{12}m, \frac{\sqrt{3}}{4}m\right)$

3. $\left(\frac{\sqrt{3}}{4}m, \frac{5}{12}m\right)$

4. $\left(\frac{\sqrt{3}}{8}m, \frac{7}{12}m\right)$

Question Number : 8 Question Type : MCQ Option Shuffling : Yes Display Question Number : Yes Single Line Question Option : No Option Orientation : Vertical

Correct Marks : 4 Wrong Marks : 1

The ratio of the weights of a body on the Earth's surface to that on the surface of a

planet is 9 : 4. The mass of the planet is $\frac{1}{9}$ th

of that of the Earth. If 'R' is the radius of the Earth, what is the radius of the planet ?

(Take the planets to have the same mass density)

Options :

1. $\frac{R}{2}$

2. $\frac{R}{3}$

3. $\frac{R}{9}$

4. $\frac{R}{4}$

Question Number : 8 Question Type : MCQ Option Shuffling : Yes Display Question Number : Yes Single Line Question Option : No Option Orientation : Vertical

Correct Marks : 4 Wrong Marks : 1

एक पिण्ड के पृथ्वी तथा एक दूसरे ग्रह की सतह पर भारों का अनुपात 9 : 4 हैं। दूसरे ग्रह का द्रव्यमान पृथ्वी के द्रव्यमान का $\frac{1}{9}$ है। यदि पृथ्वी की त्रिज्या 'R' है तो ग्रह की त्रिज्या क्या होगी? (माना कि दोनों ग्रहों का द्रव्यमान घनत्व समान है।)

Options :

1. $\frac{R}{2}$

2. $\frac{R}{3}$

3. $\frac{R}{9}$

4. $\frac{R}{4}$

Question Number : 8 Question Type : MCQ Option Shuffling : Yes Display Question Number : Yes Single Line Question Option : No Option Orientation : Vertical

Correct Marks : 4 Wrong Marks : 1

એક પદાર્થના વજનોનો પૃથ્વીની સપાટી પર અને એક ગ્રહની સપાટી પરનો ગુણોત્તર 9 : 4 છે. ગ્રહનું દળ પૃથ્વીના દળ કરતા $\frac{1}{9}$ માં ભાગનું છે. જો પૃથ્વીની ત્રિજ્યા R હોય તો ગ્રહની ત્રિજ્યા કેટલી હશે? (ગ્રહો માટે સમાન દળ ઘનતા લો)

Options :

1. $\frac{R}{2}$

2. $\frac{R}{3}$

3. $\frac{R}{9}$

4. $\frac{R}{4}$

Question Number : 9 Question Type : MCQ Option Shuffling : Yes Display Question Number : Yes Single Line Question Option : No Option Orientation : Vertical

Correct Marks : 4 Wrong Marks : 1

A uniform cylindrical rod of length L and radius r , is made from a material whose Young's modulus of Elasticity equals Y . When this rod is heated by temperature T and simultaneously subjected to a net longitudinal compressional force F , its length remains unchanged. The coefficient of volume expansion, of the material of the rod, is (nearly) equal to :

Options :

1. $6F/(\pi r^2 Y T)$
2. $9F/(\pi r^2 Y T)$
3. $3F/(\pi r^2 Y T)$
4. $F/(3\pi r^2 Y T)$

Question Number : 9 Question Type : MCQ Option Shuffling : Yes Display Question Number : Yes Single Line Question Option : No Option Orientation : Vertical

Correct Marks : 4 Wrong Marks : 1

लम्बाई L तथा त्रिज्या r की एक एकसमान बेलनाकार छड़ का यंग प्रत्यास्थता गुणांक Y है। जब इस छड़ का तापमान T से बढ़ाते हैं तथा उस पर कुल अनुदैर्घ्य संपीड़न बल F लगाते हैं, तो उसकी लम्बाई अपरिवर्तित रहती है। छड़ के पदार्थ के आयतन प्रसार गुणांक का लगभग मान होगा :

Options :

1. $6F/(\pi r^2 Y T)$
2. $9F/(\pi r^2 Y T)$
3. $3F/(\pi r^2 Y T)$
4. $F/(3\pi r^2 Y T)$

Question Number : 9 Question Type : MCQ Option Shuffling : Yes Display Question Number : Yes Single Line Question Option : No Option Orientation : Vertical

Correct Marks : 4 Wrong Marks : 1

જેનો યંગનો સ્થિતિ સ્થાપકતા અંક Y હોય તેવા દ્રવ્યમાંથી બનેલો L લંબાઈનો અને r ત્રિજ્યા ધરાવતો એક સમાંગી નળાકાર સળિયો છે. જ્યારે સળિયાને T તાપમાને ગરમ કરવામાં આવે છે તેજ સમયે તેના પર પ્રતાન (સંગત) દાબનીય બળ F પણ લગાડવામાં આવે છે, ત્યારે તેની લંબાઈમાં ફેરફાર થતો નથી. સળિયાના દ્રવ્યનો કદ પ્રસરણાંક _____ ની નજીકનો થશે.

Options :

1. $6F/(\pi r^2 Y T)$
2. $9F/(\pi r^2 Y T)$
3. $3F/(\pi r^2 Y T)$
4. $F/(3\pi r^2 Y T)$

Question Number : 10 Question Type : MCQ Option Shuffling : Yes Display Question Number : Yes Single Line Question Option : No Option Orientation : Vertical

Correct Marks : 4 Wrong Marks : 1

A solid sphere, of radius R acquires a terminal velocity v_1 when falling (due to gravity) through a viscous fluid having a coefficient of viscosity η . The sphere is broken into 27 identical solid spheres. If each of these spheres acquires a terminal velocity, v_2 , when falling through the same fluid, the ratio (v_1/v_2) equals :

Options :

1. 9
2. $1/9$
3. 27
4. $1/27$

Question Number : 10 Question Type : MCQ Option Shuffling : Yes Display Question Number : Yes Single Line Question Option : No Option Orientation : Vertical

Correct Marks : 4 Wrong Marks : 1

त्रिज्या R के एक ठोस गोले का, श्यानता गुणांक η के एक द्रव में (गुरुत्वीय बल के कारण) सीमान्त वेग v_1 है। यदि इस ठोस गोले को बराबर त्रिज्या के 27 गोलों में बाँटा जाये तो प्रत्येक गोले का सीमान्त वेग इसी द्रव में v_2 पाया जाता है, तो v_1/v_2 का मान होगा :

Options :

1. 9
2. 1/9
3. 27
4. 1/27

Question Number : 10 Question Type : MCQ Option Shuffling : Yes Display Question Number : Yes Single Line Question Option : No Option Orientation : Vertical

Correct Marks : 4 Wrong Marks : 1

η જેટલો શ્યાનતાગુણાંક (સ્નિગ્ધતા અંક) ધરાવતા એક સ્નિગ્ધ પ્રવાહીના કદમાં, એક R ત્રિજ્યા ધરાવતા ઘન ગોળાને (ગુરુત્વાકર્ષણને કારણે) પતન કરાવતા તે v_1 જેટલો ટર્મિનલ (અંતિમ) વેગ પ્રાપ્ત કરે છે. આ ગોળો એકસમાન 27 ઘન ગોળામાં તૂટે છે. જ્યારે આ તેઓને અભિનમન (બે બાજુથી બાંધેલા) પ્રવાહીમાં પતન કરાવવામાં આવે છે ત્યારે આ દરેક ગોળાઓ v_2 જેટલો અંતિમ વેગ ધારણ કરે છે, તો ગુણોત્તર v_1/v_2 _____ બરાબર થશે.

Options :

1. 9
2. 1/9
3. 27
4. 1/27

Question Number : 11 Question Type : MCQ Option Shuffling : Yes Display Question Number : Yes Single Line Question Option : No Option Orientation : Vertical

Correct Marks : 4 Wrong Marks : 1

A Carnot engine has an efficiency of $1/6$. When the temperature of the sink is reduced by 62°C , its efficiency is doubled. The temperatures of the source and the sink are, respectively,

Options :

1. 99°C , 37°C
2. 124°C , 62°C
3. 37°C , 99°C
4. 62°C , 124°C

Question Number : 11 Question Type : MCQ Option Shuffling : Yes Display Question Number : Yes Single Line Question Option : No Option Orientation : Vertical

Correct Marks : 4 Wrong Marks : 1

एक कार्नो इंजन की क्षमता $1/6$ है। जब ऊष्मा कुण्ड (sink) का तापमान 62°C कम किया जाता है तो क्षमता दोगुनी हो जाती है। ऊष्मा स्रोत तथा कुण्ड के, क्रमशः, तापमान होंगे :

Options :

1. 99°C , 37°C
2. 124°C , 62°C
3. 37°C , 99°C
4. 62°C , 124°C

Question Number : 11 Question Type : MCQ Option Shuffling : Yes Display Question Number : Yes Single Line Question Option : No Option Orientation : Vertical

Correct Marks : 4 Wrong Marks : 1

એક કાર્નો એન્જિનની કાર્યક્ષમતા $1/6$ છે. જ્યારે ઠારણનું તાપમાન 62°C જેટલું ઘટાડવામાં આવે છે ત્યારે તેની કાર્યક્ષમતા બમણી થાય છે. ઊષ્માપ્રાપ્તિ સ્થાન અને ઠારણના પ્રારંભિક તાપમાનો, અનુક્રમે _____.

Options :

1. 99°C , 37°C

2. $124^{\circ}\text{C}, 62^{\circ}\text{C}$
3. $37^{\circ}\text{C}, 99^{\circ}\text{C}$
4. $62^{\circ}\text{C}, 124^{\circ}\text{C}$

Question Number : 12 Question Type : MCQ Option Shuffling : Yes Display Question Number : Yes Single Line Question Option : No Option Orientation : Vertical

Correct Marks : 4 Wrong Marks : 1

A diatomic gas with rigid molecules does 10 J of work when expanded at constant pressure. What would be the heat energy absorbed by the gas, in this process ?

Options :

1. 25 J
2. 30 J
3. 35 J
4. 40 J

Question Number : 12 Question Type : MCQ Option Shuffling : Yes Display Question Number : Yes Single Line Question Option : No Option Orientation : Vertical

Correct Marks : 4 Wrong Marks : 1

एक दृढ़ अणुओं वाली द्विपरमाणुक गैस का जब नियत दाब पर प्रसार होता है तो वह 10 J कार्य करती है। इस प्रक्रम में गैस द्वारा अवशोषित ऊष्मा का मान होगा :

Options :

1. 25 J
2. 30 J
3. 35 J
4. 40 J

Question Number : 12 Question Type : MCQ Option Shuffling : Yes Display Question Number : Yes Single Line Question Option : No Option Orientation : Vertical

Correct Marks : 4 Wrong Marks : 1

એક દ્વિપરમાણુક વાયુનું અચળ દબાણે વિસ્તરણ કરતા 10 J જેટલું કાર્ય કરે છે. આ પ્રક્રિયામાં વાયુ દ્વારા શોષાતી ગ્રીન્હાઉર્ન કેટલી હશે ?

Options :

1. 25 J
2. 30 J
3. 35 J
4. 40 J

Question Number : 13 Question Type : MCQ Option Shuffling : Yes Display Question Number : Yes Single Line Question Option : No Option Orientation : Vertical

Correct Marks : 4 Wrong Marks : 1

A small speaker delivers 2 W of audio output. At what distance from the speaker will one detect 120 dB intensity sound ?
[Given reference intensity of sound as 10^{-12} W/m^2]

Options :

1. 10 cm
2. 20 cm
3. 30 cm
4. 40 cm

Question Number : 13 Question Type : MCQ Option Shuffling : Yes Display Question Number : Yes Single Line Question Option : No Option Orientation : Vertical

Correct Marks : 4 Wrong Marks : 1

એક ઢોટે સ્પીકર સે 2 W શક્તિ કી ઢ્વનિ નિકલતી હૈ ।
ઇસ સ્પીકર સે કિતની દૂરી પર ઢ્વનિ તીવ્રતા 120 dB હોગી ? [દિયા હૈ : ઢ્વનિ કી નિર્દેશ (reference) તીવ્રતા = 10^{-12} W/m^2]

Options :

1. 10 cm
2. 20 cm

3. 30 cm

4. 40 cm

Question Number : 13 Question Type : MCQ Option Shuffling : Yes Display Question Number : Yes Single Line Question Option : No Option Orientation : Vertical

Correct Marks : 4 Wrong Marks : 1

એક નાનું સ્પીકર 2 W જેટલો શ્રાવ્ય (audio) આઉટપુટ આપે છે. સ્પીકરથી કેટલા અંતરે 120 dB જેટલી ધ્વનિ તીવ્રતા નોંધી શકાય?

[ધ્વનિની આપેલ સંદર્ભ તીવ્રતા 10^{-12} W/m^2 છે]

Options :

1. 10 cm

2. 20 cm

3. 30 cm

4. 40 cm

Question Number : 14 Question Type : MCQ Option Shuffling : Yes Display Question Number : Yes Single Line Question Option : No Option Orientation : Vertical

Correct Marks : 4 Wrong Marks : 1

Two sources of sound S_1 and S_2 produce sound waves of same frequency 660 Hz. A listener is moving from source S_1 towards S_2 with a constant speed u m/s and he hears 10 beats/s. The velocity of sound is 330 m/s. Then, u equals :

Options :

1. 2.5 m/s

2. 5.5 m/s

3. 10.0 m/s

4. 15.0 m/s

Question Number : 14 Question Type : MCQ Option Shuffling : Yes Display Question Number : Yes Single Line Question Option : No Option Orientation : Vertical

Correct Marks : 4 Wrong Marks : 1

दो ध्वनि स्रोत, S_1 तथा S_2 , एक ही आवृत्ति 660 Hz की ध्वनि उत्पन्न करते हैं। एक श्रोता S_1 से S_2 की तरफ स्थिर गति u से जाते हुये प्रति सेकण्ड 10 विस्पंद सुनता है। यदि ध्वनि की गति 330 m/s है, तो u का मान होगा :

Options :

1. 2.5 m/s
2. 5.5 m/s
3. 10.0 m/s
4. 15.0 m/s

Question Number : 14 Question Type : MCQ Option Shuffling : Yes Display Question Number : Yes Single Line Question Option : No Option Orientation : Vertical

Correct Marks : 4 Wrong Marks : 1

બે ધ્વનિ ઉદ્ગમો S_1 અને S_2 સમાન 660 Hz આવૃત્તિના ધ્વનિ તરંગો ઉત્પન્ન કરે છે. એક શ્રોતા u જેટલા અચળ ઝડપથી ઉદ્ગમ S_1 થી S_2 તરફ ગતિ કરે છે. અને તે 10 સ્પંદ/સેકન્ડ સાંભળે છે. ધ્વનિનો વેગ 330 m/s છે. તો u _____ છે.

Options :

1. 2.5 m/s
2. 5.5 m/s
3. 10.0 m/s
4. 15.0 m/s

Question Number : 15 Question Type : MCQ Option Shuffling : Yes Display Question Number : Yes Single Line Question Option : No Option Orientation : Vertical

Correct Marks : 4 Wrong Marks : 1

Let a total charge $2Q$ be distributed in a sphere of radius R , with the charge density given by $\rho(r) = kr$, where r is the distance from the centre. Two charges A and B , of $-Q$ each, are placed on diametrically opposite points, at equal distance, a , from the centre. If A and B do not experience any force, then :

Options :

1. $a = 8^{-1/4} R$

2. $a = 2^{-1/4} R$

3. $a = R/\sqrt{3}$

4. $a = \frac{3R}{2^{1/4}}$

Question Number : 15 Question Type : MCQ Option Shuffling : Yes Display Question Number : Yes Single Line Question Option : No Option Orientation : Vertical

Correct Marks : 4 Wrong Marks : 1

कुल आवेश $2Q$ को त्रिज्या R के गोले में इस प्रकार वितरित करते हैं कि आवेश घनत्व सम्बन्ध $\rho(r) = kr$ से दिया जाता है जहाँ r , केन्द्र से दूरी है। दो बराबर $-Q$ आवेशों A तथा B को केन्द्र से a दूरी पर व्यासीय विपरीत बिन्दुओं पर रखा गया है। यदि A और B कोई बल अनुभव नहीं करते हैं, तो :

Options :

1. $a = 8^{-1/4} R$

2. $a = 2^{-1/4} R$

3. $a = R/\sqrt{3}$

4. $a = \frac{3R}{2^{1/4}}$

Question Number : 15 Question Type : MCQ Option Shuffling : Yes Display Question Number : Yes Single Line Question Option : No Option Orientation : Vertical

Correct Marks : 4 Wrong Marks : 1

ધારોકે $2Q$ જેટલો કુલ વિદ્યુતભાર R ત્રિજ્યાના ગોળાની અંદરના ભાગમાં $\rho(r) = kr$ સુત્ર અનુસાર જેટલી વિદ્યુતભાર ઘનતા મુજબ વહેંચાયેલ છે. જ્યાં r એ કેન્દ્રથી અંતર છે દરેક $-Q$ જેટલા બે વિદ્યુતભારો A અને B ને કેન્દ્રથી a જેટલા સમાન અંતરે અને વિરુદ્ધ વ્યાસાંતે રહેલા બિંદુઓ પર મૂકવામાં આવે છે. જો A અને B કોઈપણ બળ અનુભવતા ના હોય, તો _____.

Options :

1. $a = 8^{-1/4} R$

2. $a = 2^{-1/4} R$

3. $a = R/\sqrt{3}$

4. $a = \frac{3R}{2^{1/4}}$

Question Number : 16 Question Type : MCQ Option Shuffling : Yes Display Question Number : Yes Single Line Question Option : No Option Orientation : Vertical

Correct Marks : 4 Wrong Marks : 1

In the given circuit, the charge on $4 \mu F$ capacitor will be :

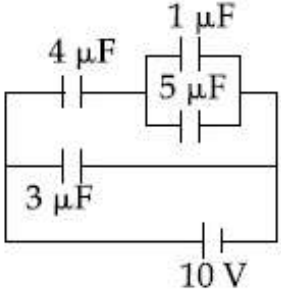

Options :

1. $9.6 \mu C$

2. $24 \mu C$

3. $5.4 \mu C$

4. $13.4 \mu C$

Question Number : 16 Question Type : MCQ Option Shuffling : Yes Display Question Number : Yes Single Line Question Option : No Option Orientation : Vertical

Correct Marks : 4 Wrong Marks : 1

दिये गये परिपथ में $4\ \mu\text{F}$ धारिता के संधारित्र पर आवेश का मान होगा :

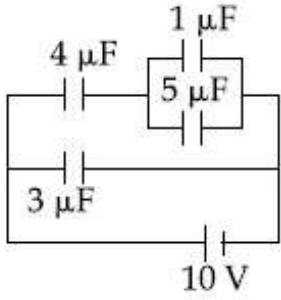

Options :

1. $9.6\ \mu\text{C}$
2. $24\ \mu\text{C}$
3. $5.4\ \mu\text{C}$
4. $13.4\ \mu\text{C}$

Question Number : 16 Question Type : MCQ Option Shuffling : Yes Display Question Number : Yes Single Line Question Option : No Option Orientation : Vertical

Correct Marks : 4 Wrong Marks : 1

આપેલ પરિપથમાં $4\ \mu\text{F}$ કેપેસિટર પરનો વિદ્યુતભાર

_____.

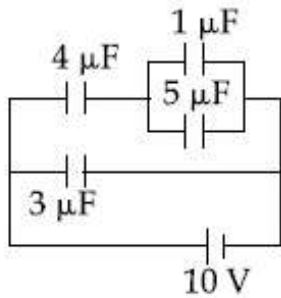

Options :

1. $9.6\ \mu\text{C}$
2. $24\ \mu\text{C}$
3. $5.4\ \mu\text{C}$
4. $13.4\ \mu\text{C}$

Question Number : 17 Question Type : MCQ Option Shuffling : Yes Display Question Number : Yes Single Line Question Option : No Option Orientation : Vertical

Correct Marks : 4 Wrong Marks : 1

One kg of water, at 20°C , is heated in an electric kettle whose heating element has a mean (temperature averaged) resistance of $20\ \Omega$. The rms voltage in the mains is $200\ \text{V}$. Ignoring heat loss from the kettle, time taken for water to evaporate fully, is close to :

[Specific heat of water = $4200\ \text{J}/(\text{kg}\ ^{\circ}\text{C})$,
Latent heat of water = $2260\ \text{kJ}/\text{kg}$]

Options :

1. 3 minutes
2. 10 minutes
3. 22 minutes
4. 16 minutes

Question Number : 17 Question Type : MCQ Option Shuffling : Yes Display Question Number : Yes Single Line Question Option : No Option Orientation : Vertical

Correct Marks : 4 Wrong Marks : 1

माध्य प्रतिरोध (तापमान औसत) $20\ \Omega$ की एक विद्युत केतली में 20°C के $1\ \text{kg}$ पानी को उबालते हैं। विद्युत आपूर्ति की rms वोल्टता $200\ \text{V}$ है। केतली से ऊष्मा हानि को नगण्य मानते हुए, पानी को पूर्णतया वाष्पित होने में लगभग समय लगेगा :

[पानी की विशिष्ट ऊष्मा = $4200\ \text{J}/(\text{kg}\ ^{\circ}\text{C})$,
पानी की गुप्त ऊष्मा = $2260\ \text{kJ}/\text{kg}$]

Options :

1. 3 मिनट
2. 10 मिनट
3. 22 मिनट
4. 16 मिनट

Question Number : 17 Question Type : MCQ Option Shuffling : Yes Display Question Number : Yes Single Line Question Option : No Option Orientation : Vertical

Correct Marks : 4 Wrong Marks : 1

20°C તાપમાન રહેલ 1 kg દળ ધરાવતા પાણીને ઇલેક્ટ્રિક કીટલી વડે ગરમ કરવામાં આવે છે કે જેના (ગરમ કરવાના) તારનો (ફિલામેન્ટનો) (તાપમાન-સરેરાશ) સરેરાશ અવરોધ 20 Ω છે. મેઇન્સનો rms વોલ્ટેજ 200 V છે. ઊષ્મીય વ્યય અવગણતા, સંપૂર્ણ પાણીનું બાષ્પીભવન થતા લાગતો સમય _____ ની નજીકનો છે.

[પાણીની વિશિષ્ટ ઉષ્મા = 4200 J/(kg °C), પાણીની ગલન ગુપ્ત ઊષ્મા = 2260 kJ/kg]

Options :

1. 3 મિનિટ
2. 10 મિનિટ
3. 22 મિનિટ
4. 16 મિનિટ

Question Number : 18 Question Type : MCQ Option Shuffling : Yes Display Question Number : Yes Single Line Question Option : No Option Orientation : Vertical

Correct Marks : 4 Wrong Marks : 1

An electron, moving along the x -axis with an initial energy of 100 eV, enters a region

of magnetic field $\vec{B} = (1.5 \times 10^{-3} \text{T}) \hat{k}$ at S (See figure). The field extends between $x=0$ and $x=2$ cm. The electron is detected at the point Q on a screen placed 8 cm away from the point S. The distance d between P and Q (on the screen) is :

(electron's charge = $1.6 \times 10^{-19} \text{C}$, mass of electron = $9.1 \times 10^{-31} \text{kg}$)

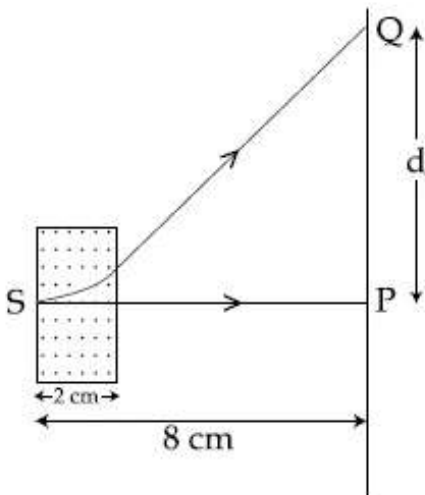

Options :

1. 1.22 cm
2. 12.87 cm
3. 11.65 cm
4. 2.25 cm

Question Number : 18 Question Type : MCQ Option Shuffling : Yes Display Question Number : Yes Single Line Question Option : No Option Orientation : Vertical

Correct Marks : 4 Wrong Marks : 1

100 eV ऊर्जा का एक इलेक्ट्रॉन जो x -अक्ष के अनुदिश

गतिमान है, $\vec{B} = (1.5 \times 10^{-3} \text{T}) \hat{k}$ के चुम्बकीय क्षेत्र में बिन्दु S पर प्रवेश करता है (चित्र देखिये)। चुम्बकीय क्षेत्र $x=0$ से $x=2 \text{ cm}$ तक विस्तृत है। बिन्दु S से 8 cm दूरी पर स्थित पर्दे पर इलेक्ट्रॉन का संसूचन बिन्दु Q पर होता है। बिन्दु P तथा Q के बीच की दूरी d (पर्दे पर) का मान होगा :

(इलेक्ट्रॉन का आवेश $= 1.6 \times 10^{-19} \text{C}$, इलेक्ट्रॉन का द्रव्यमान $= 9.1 \times 10^{-31} \text{kg}$)

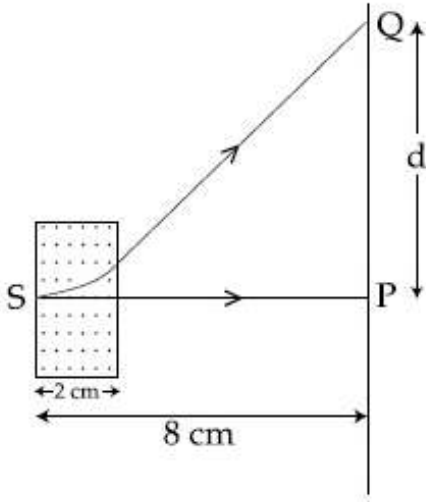

Options :

1. 1.22 cm
2. 12.87 cm
3. 11.65 cm
4. 2.25 cm

Question Number : 18 Question Type : MCQ Option Shuffling : Yes Display Question Number : Yes Single Line Question Option : No Option Orientation : Vertical

Correct Marks : 4 Wrong Marks : 1

100 eV જેટલી પ્રારંભિક ઊર્જા ધરાવતો એક ઇલેક્ટ્રોન

x - અક્ષની દિશામાં ગતિ કરતા, $\vec{B} = (1.5 \times 10^{-3} \text{T}) \hat{k}$ જેટલા ચુંબકીય ક્ષેત્ર ધરાવતા વિસ્તારમાં S આગળ (આકૃતિ જુઓ) દાખલ થાય છે. આ ક્ષેત્ર $x=0$ અને $x=2 \text{ cm}$ વચ્ચે પ્રસરેલું છે. આ ઇલેક્ટ્રોન, S થી 8 cm અંતરે રહેલા પડદા પરના Q બિંદુ આગળ નોંધાય છે. (પડદા પર) બિંદુ P અને Q વચ્ચેનું અંતર d :

(ઇલેક્ટ્રોનનો વિદ્યુતભાર $= 1.6 \times 10^{-19} \text{C}$, ઇલેક્ટ્રોનનું દળ $= 9.1 \times 10^{-31} \text{ kg}$)

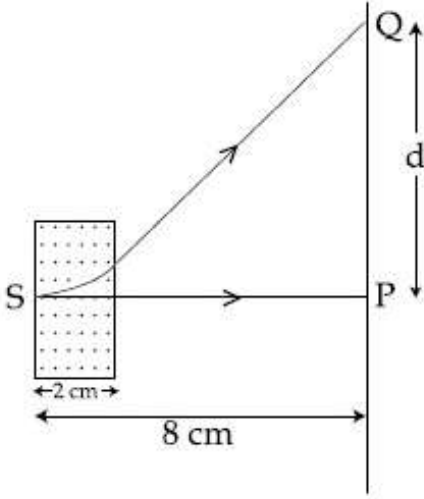

Options :

1. 1.22 cm
2. 12.87 cm
3. 11.65 cm
4. 2.25 cm

Question Number : 19 Question Type : MCQ Option Shuffling : Yes Display Question Number : Yes Single Line Question Option : No Option Orientation : Vertical

Correct Marks : 4 Wrong Marks : 1

Find the magnetic field at point P due to a straight line segment AB of length 6 cm carrying a current of 5 A. (See figure)

$$(\mu_0 = 4\pi \times 10^{-7} \text{ N-A}^{-2})$$

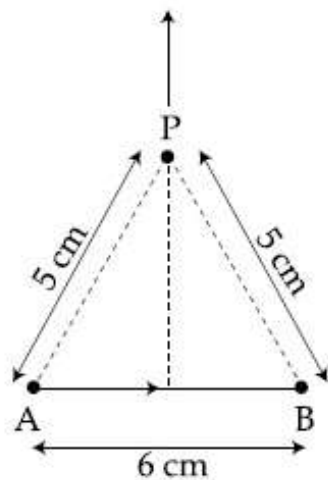

Options :

1. $1.5 \times 10^{-5} \text{ T}$
2. $2.0 \times 10^{-5} \text{ T}$
3. $2.5 \times 10^{-5} \text{ T}$
4. $3.0 \times 10^{-5} \text{ T}$

Question Number : 19 Question Type : MCQ Option Shuffling : Yes Display Question Number : Yes Single Line Question Option : No Option Orientation : Vertical

Correct Marks : 4 Wrong Marks : 1

5 A धारा के एक सीधे तार के 6 cm लम्बे खण्ड AB के कारण, (चित्रानुसार), बिन्दु P पर चुम्बकीय क्षेत्र ज्ञात कीजिए।

$$(\mu_0 = 4\pi \times 10^{-7} \text{ N-A}^{-2})$$

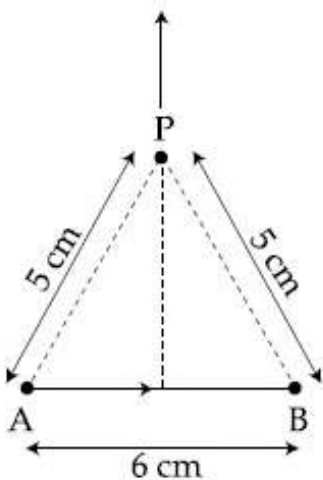

Options :

1. $1.5 \times 10^{-5} \text{ T}$
2. $2.0 \times 10^{-5} \text{ T}$
3. $2.5 \times 10^{-5} \text{ T}$
4. $3.0 \times 10^{-5} \text{ T}$

Question Number : 19 Question Type : MCQ Option Shuffling : Yes Display Question Number : Yes Single Line Question Option : No Option Orientation : Vertical

Correct Marks : 4 Wrong Marks : 1

आकृतिमां दृशाव्या अनुसार, 6cm लंबाई धरावता सीधा प्रवाह धारित (5 A) अंश AB थी बिंदु P आगण चुंबकीय क्षेत्र शोधो?

$$(\mu_0 = 4\pi \times 10^{-7} \text{ N-A}^{-2})$$

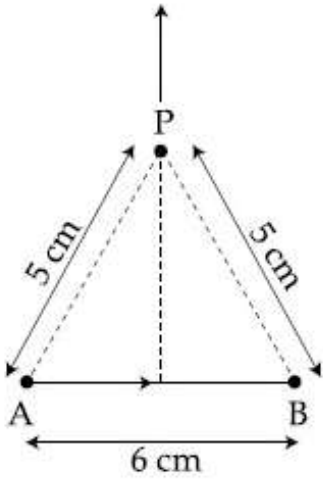

Options :

1. $1.5 \times 10^{-5} \text{ T}$
2. $2.0 \times 10^{-5} \text{ T}$
3. $2.5 \times 10^{-5} \text{ T}$
4. $3.0 \times 10^{-5} \text{ T}$

Question Number : 20 Question Type : MCQ Option Shuffling : Yes Display Question Number : Yes Single Line Question Option : No Option Orientation : Vertical

Correct Marks : 4 Wrong Marks : 1

Consider the LR circuit shown in the figure.
If the switch S is closed at $t=0$ then the amount of charge that passes through the

battery between $t=0$ and $t=\frac{L}{R}$ is :

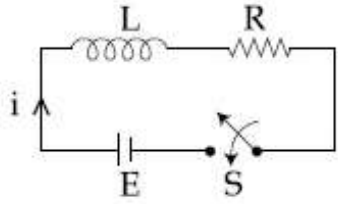

Options :

1. $\frac{7.3 EL}{R^2}$

2. $\frac{2.7 EL}{R^2}$

3. $\frac{EL}{2.7R^2}$

4. $\frac{EL}{7.3R^2}$

Question Number : 20 Question Type : MCQ Option Shuffling : Yes Display Question Number : Yes Single Line Question Option : No Option Orientation : Vertical

Correct Marks : 4 Wrong Marks : 1

चित्र में एक LR परिपथ दर्शाया है। यदि $t=0$ पर कुँजी S को बन्द करते हैं, तो सेल से निकलने वाले

आवेश का मान समयान्तराल $t=0$ से $t=\frac{L}{R}$ के बीच

होगा :

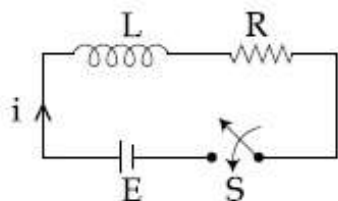

Options :

1. $\frac{7.3 EL}{R^2}$

2. $\frac{2.7 EL}{R^2}$

3. $\frac{EL}{2.7R^2}$

4. $\frac{EL}{7.3R^2}$

Question Number : 20 Question Type : MCQ Option Shuffling : Yes Display Question Number : Yes Single Line Question Option : No Option Orientation : Vertical

Correct Marks : 4 Wrong Marks : 1

આકૃતિમાં દર્શાવેલ LR પરિપથ ધ્યાનમાં લો. જો $t=0$

સમયે કળ બંધ હોય તો બેટરીમાંથી $t=0$ અને $t=\frac{L}{R}$

વચ્ચે પસાર થતો વિદ્યુતભાર :

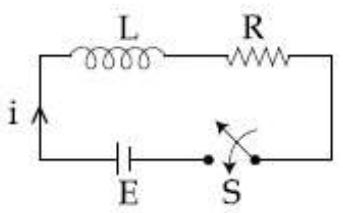

Options :

1. $\frac{7.3 EL}{R^2}$

2. $\frac{2.7 EL}{R^2}$

3. $\frac{EL}{2.7R^2}$

4. $\frac{EL}{7.3R^2}$

Question Number : 21 Question Type : MCQ Option Shuffling : Yes Display Question Number : Yes Single Line Question Option : No Option Orientation : Vertical

Correct Marks : 4 Wrong Marks : 1

A plane electromagnetic wave having a frequency $\nu = 23.9$ GHz propagates along the positive z -direction in free space. The peak value of the Electric Field is 60 V/m. Which among the following is the acceptable magnetic field component in the electromagnetic wave ?

Options :

1. $\vec{B} = 60 \sin(0.5 \times 10^3 x + 1.5 \times 10^{11} t) \hat{k}$

2. $\vec{B} = 2 \times 10^{-7} \sin(0.5 \times 10^3 z - 1.5 \times 10^{11} t) \hat{i}$

3. $\vec{B} = 2 \times 10^7 \sin(0.5 \times 10^3 z + 1.5 \times 10^{11} t) \hat{i}$

4. $\vec{B} = 2 \times 10^{-7} \sin(1.5 \times 10^2 x + 0.5 \times 10^{11} t) \hat{j}$

Question Number : 21 Question Type : MCQ Option Shuffling : Yes Display Question Number : Yes Single Line Question Option : No Option Orientation : Vertical

Correct Marks : 4 Wrong Marks : 1

मुक्त आकाश में $\nu = 23.9$ GHz की एक समतल विद्युत चुम्बकीय तरंग धनात्मक z -अक्ष की दिशा में संचरण कर रही है। इसमें विद्युत क्षेत्र का अधिकतम मान 60 V/m है। निम्न में से कौन सा विकल्प इस तरंग के चुम्बकीय क्षेत्र के लिये स्वीकार्य है ?

Options :

1. $\vec{B} = 60 \sin(0.5 \times 10^3 x + 1.5 \times 10^{11} t) \hat{k}$

2. $\vec{B} = 2 \times 10^{-7} \sin(0.5 \times 10^3 z - 1.5 \times 10^{11} t) \hat{i}$

3. $\vec{B} = 2 \times 10^7 \sin(0.5 \times 10^3 z + 1.5 \times 10^{11} t) \hat{i}$

4. $\vec{B} = 2 \times 10^{-7} \sin(1.5 \times 10^2 x + 0.5 \times 10^{11} t) \hat{j}$

Question Number : 21 Question Type : MCQ Option Shuffling : Yes Display Question Number : Yes Single Line Question Option : No Option Orientation : Vertical

Correct Marks : 4 Wrong Marks : 1

$v = 23.9 \text{ GHz}$ આવૃત્તિ ધરાવતું એક સમતલ વિદ્યુતચુંબકીય તરંગ મુક્ત અવકાશમાં ધન z -દિશામાં ગતિ કરે છે. વિદ્યુતક્ષેત્રનું મહત્તમ મૂલ્ય 60 V/m છે. વિદ્યુતચુંબકીય તરંગમાં સ્વીકાર્ય હોય તેવા ચુંબકીય ક્ષેત્રનો નીચેનામાંથી કયો ઘટક સ્વીકાર્ય હશે?

Options :

1. $\vec{B} = 60 \sin(0.5 \times 10^3 x + 1.5 \times 10^{11} t) \hat{k}$

2. $\vec{B} = 2 \times 10^{-7} \sin(0.5 \times 10^3 z - 1.5 \times 10^{11} t) \hat{i}$

3. $\vec{B} = 2 \times 10^7 \sin(0.5 \times 10^3 z + 1.5 \times 10^{11} t) \hat{i}$

4. $\vec{B} = 2 \times 10^{-7} \sin(1.5 \times 10^2 x + 0.5 \times 10^{11} t) \hat{j}$

Question Number : 22 Question Type : MCQ Option Shuffling : Yes Display Question Number : Yes Single Line Question Option : No Option Orientation : Vertical

Correct Marks : 4 Wrong Marks : 1

A transparent cube of side d , made of a material of refractive index μ_2 , is immersed in a liquid of refractive index μ_1 ($\mu_1 < \mu_2$). A ray is incident on the face AB at an angle θ (shown in the figure). Total internal reflection takes place at point E on the face BC.

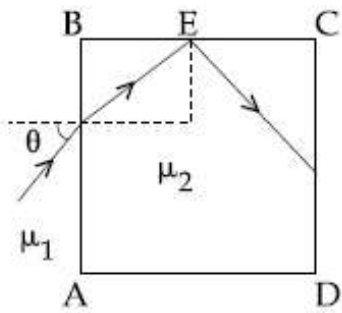

Then θ must satisfy :

Options :

1. $\theta < \sin^{-1} \sqrt{\frac{\mu_2}{\mu_1} - 1}$

2. $\theta > \sin^{-1} \sqrt{\frac{\mu_2}{\mu_1} - 1}$

3. $\theta > \sin^{-1} \frac{\mu_1}{\mu_2}$

4. $\theta < \sin^{-1} \frac{\mu_1}{\mu_2}$

Question Number : 22 Question Type : MCQ Option Shuffling : Yes Display Question Number : Yes Single Line Question Option : No Option Orientation : Vertical

Correct Marks : 4 Wrong Marks : 1

अपवर्तनांक μ_1 के एक द्रव में अपवर्तनांक $\mu_2 (\mu_1 < \mu_2)$ के पारदर्शी गुटके को डुबाया जाता है। प्रकाश की एक किरण इस गुटके के पृष्ठ AB पर द्रव से, चित्रानुसार, θ कोण पर आपतित होती है। पृष्ठ BC के बिन्दु E पर पूर्ण आन्तरिक परावर्तन होने के लिये, θ का मान कौन सा सम्बन्ध संतुष्ट करेगा ?

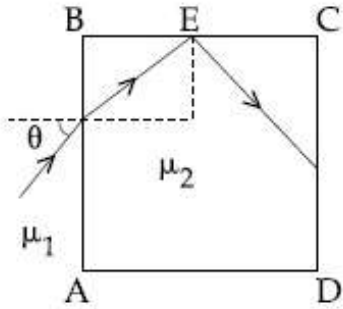

Options :

1. $\theta < \sin^{-1} \sqrt{\frac{\mu_2^2}{\mu_1^2} - 1}$

2. $\theta > \sin^{-1} \sqrt{\frac{\mu_2^2}{\mu_1^2} - 1}$

3. $\theta > \sin^{-1} \frac{\mu_1}{\mu_2}$

4. $\theta < \sin^{-1} \frac{\mu_1}{\mu_2}$

Question Number : 22 Question Type : MCQ Option Shuffling : Yes Display Question Number : Yes Single Line Question Option : No Option Orientation : Vertical

Correct Marks : 4 Wrong Marks : 1

દ જેટલી બાજુ ધરાવતો અને μ_2 જેટલો વક્રીભવનાંક ધરાવતા માધ્યમમાંથી બનેલા એક પારદર્શક સમઘનને μ_1 જેટલો વક્રીભવનાંક ધરાવતા પ્રવાહીમાં ડુબાડવામાં આવે છે ($\mu_1 < \mu_2$). AB બાજુ પર θ કોણે (આકૃતિમાં દર્શાવ્યા અનુસાર) એક કિરણ આપાત કરવામાં આવે છે. બાજુ BC પર બિંદુ E આગળ પૂર્ણઆંતરિક પરાવર્તન અનુભવાય છે.

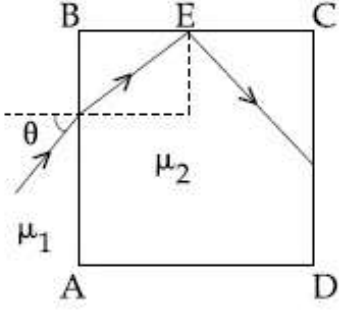

θ નું મૂલ્ય _____ અનુસરતું હોવું જ જોઈએ.

Options :

1. $\theta < \sin^{-1} \sqrt{\frac{\mu_2^2}{\mu_1^2} - 1}$

2. $\theta > \sin^{-1} \sqrt{\frac{\mu_2^2}{\mu_1^2} - 1}$

3. $\theta > \sin^{-1} \frac{\mu_1}{\mu_2}$

4. $\theta < \sin^{-1} \frac{\mu_1}{\mu_2}$

Question Number : 23 Question Type : MCQ Option Shuffling : Yes Display Question Number : Yes Single Line Question Option : No Option Orientation : Vertical

Correct Marks : 4 Wrong Marks : 1

A system of three polarizers P_1, P_2, P_3 is set up such that the pass axis of P_3 is crossed with respect to that of P_1 . The pass axis of P_2 is inclined at 60° to the pass axis of P_3 . When a beam of unpolarized light of intensity I_0 is incident on P_1 , the intensity of light transmitted by the three polarizers is I . The ratio (I_0/I) equals (nearly) :

Options :

1. 1.80
2. 5.33
3. 10.67
4. 16.00

Question Number : 23 Question Type : MCQ Option Shuffling : Yes Display Question Number : Yes Single Line Question Option : No Option Orientation : Vertical

Correct Marks : 4 Wrong Marks : 1

तीन ध्रुवकों P_1 , P_2 तथा P_3 को इस तरह रखते हैं कि P_3 की पास-अक्ष P_1 की पास-अक्ष से क्रॉसित है। P_2 की पास-अक्ष P_3 की पास-अक्ष से 60° कोण पर है। जब एक I_0 तीव्रता का अध्रुवित प्रकाश किरण पुंज P_1 पर आपतित होता है तो इस तीन ध्रुवकों के समायोजन से I तीव्रता का प्रकाश किरण पुंज निर्गत होता है। अनुपात (I_0/I) का निकटतम मान होगा :

Options :

1. 1.80
2. 5.33
3. 10.67
4. 16.00

Question Number : 23 Question Type : MCQ Option Shuffling : Yes Display Question Number : Yes Single Line Question Option : No Option Orientation : Vertical

Correct Marks : 4 Wrong Marks : 1

ત્રણ ધ્રુવક (પોલરાઇઝર) P_1 , P_2 અને P_3 નું એક તંત્ર એવી રીતે રચવામાં આવે છે કે બેથી પોલરાઇઝર P_3 ની દક્ષ-અક્ષ P_1 ની દક્ષ-અક્ષ ને લંબ રૂપે રહે. પોલરાઇઝર P_2 ની દક્ષ-અક્ષ, P_3 ની દક્ષ-અક્ષને 60° કોણે નમેલી છે. જ્યારે I_0 તીવ્રતા ધરાવતો અધ્રુવીભૂત પ્રકાશ પોલરાઇઝર P_1 પર આપાત કરવામાં આવે છે, ત્યારે તંત્રમાંથી નિર્ગમન પામતી તીવ્રતા I મળે છે. (I_0/I) ગુણોત્તર _____ ની નજીકનો હશે.

Options :

1. 1.80

2. 5.33
3. 10.67
4. 16.00

Question Number : 24 Question Type : MCQ Option Shuffling : Yes Display Question Number : Yes Single Line Question Option : No Option Orientation : Vertical

Correct Marks : 4 Wrong Marks : 1

Consider an electron in a hydrogen atom, revolving in its second excited state (having radius 4.65 \AA). The de-Broglie wavelength of this electron is :

Options :

1. 3.5 \AA
2. 6.6 \AA
3. 9.7 \AA
4. 12.9 \AA

Question Number : 24 Question Type : MCQ Option Shuffling : Yes Display Question Number : Yes Single Line Question Option : No Option Orientation : Vertical

Correct Marks : 4 Wrong Marks : 1

एक हाइड्रोजन परमाणु में इलेक्ट्रॉन दूसरी उत्तेजित कक्षा में घूम रहा है। (इस कक्षा की त्रिज्या 4.65 \AA है।) इस इलेक्ट्रॉन की डि-ब्रॉग्ली तरंगदैर्घ्य होगी :

Options :

1. 3.5 \AA
2. 6.6 \AA
3. 9.7 \AA
4. 12.9 \AA

Question Number : 24 Question Type : MCQ Option Shuffling : Yes Display Question Number : Yes Single Line Question Option : No Option Orientation : Vertical

Correct Marks : 4 Wrong Marks : 1

હાઇડ્રોજન પરમાણુમાંના ઇલેક્ટ્રોનને ધ્યાનમાં લો કે જે તેની દ્વિતીય ઉત્તેજિત અવસ્થા (4.65\AA જેટલી ત્રિજ્યા) માં ભ્રમણ કરે છે. આ ઇલેક્ટ્રોન સાથે સંકળાયેલ ડી-બ્રોગ્લી તરંગલંબાઈ _____.

Options :

1. 3.5\AA
2. 6.6\AA
3. 9.7\AA
4. 12.9\AA

Question Number : 25 Question Type : MCQ Option Shuffling : Yes Display Question Number : Yes Single Line Question Option : No Option Orientation : Vertical

Correct Marks : 4 Wrong Marks : 1

The electron in a hydrogen atom first jumps from the third excited state to the second excited state and subsequently to the first excited state. The ratio of the respective wavelengths, λ_1/λ_2 , of the photons emitted in this process is :

Options :

1. $27/5$
2. $7/5$
3. $9/7$
4. $20/7$

Question Number : 25 Question Type : MCQ Option Shuffling : Yes Display Question Number : Yes Single Line Question Option : No Option Orientation : Vertical

Correct Marks : 4 Wrong Marks : 1

एक हाइड्रोजन परमाणु में इलेक्ट्रॉन पहले तीसरी उत्तेजित अवस्था से दूसरी उत्तेजित अवस्था में और तत्पश्चात् दूसरी से प्रथम उत्तेजित अवस्था में जाता है। इन दो संक्रमणों में उत्सर्जित फोटॉनों के संगत तरंगदैर्घ्यों का अनुपात λ_1/λ_2 होगा :

Options :

1. 27/5
2. 7/5
3. 9/7
4. 20/7

Question Number : 25 Question Type : MCQ Option Shuffling : Yes Display Question Number : Yes Single Line Question Option : No Option Orientation : Vertical

Correct Marks : 4 Wrong Marks : 1

એક ઉત્તેજિત અવસ્થામાં રહેલા હાઇડ્રોજન પરમાણુમાં એક ઇલેક્ટ્રોન પ્રથમ તૃતીય ઉત્તેજિત અવસ્થામાંથી દ્વિતીય ઉત્તેજિત અવસ્થામાં અને પછી પ્રથમ ઉત્તેજિત અવસ્થામાં સંક્રાંતિ કરે છે. આ પ્રક્રિયા દરમિયાન અનુક્રમે ઉત્સર્જિત વિકિરણની તરંગલંબાઈઓનો ગુણોત્તર λ_1/λ_2 :

Options :

1. 27/5
2. 7/5
3. 9/7
4. 20/7

Question Number : 26 Question Type : MCQ Option Shuffling : Yes Display Question Number : Yes Single Line Question Option : No Option Orientation : Vertical

Correct Marks : 4 Wrong Marks : 1

Half lives of two radioactive nuclei A and B are 10 minutes and 20 minutes, respectively. If, initially a sample has equal number of nuclei, then after 60 minutes, the ratio of decayed numbers of nuclei A and B will be :

Options :

1. 1 : 8
2. 9 : 8
3. 8 : 1

4. 3 : 8

Question Number : 26 Question Type : MCQ Option Shuffling : Yes Display Question Number : Yes Single Line Question Option : No Option Orientation : Vertical

Correct Marks : 4 Wrong Marks : 1

दो रेडियोधर्मी नाभिकों, A तथा B, की अर्धआयु, क्रमशः, 10 minutes तथा 20 minutes है। यदि एक नमूने में आरम्भ में दोनों नाभिकों की संख्या बराबर है तो 60 minutes पश्चात् A तथा B के क्षयित नाभिकों की संख्या का अनुपात होगा :

Options :

1. 1 : 8
2. 9 : 8
3. 8 : 1
4. 3 : 8

Question Number : 26 Question Type : MCQ Option Shuffling : Yes Display Question Number : Yes Single Line Question Option : No Option Orientation : Vertical

Correct Marks : 4 Wrong Marks : 1

બે રેડિઓએક્ટિવ ન્યૂક્લિયસો A અને B નો અર્ધઆયુ અનુક્રમે 10 મિનિટ અને 20 મિનિટ છે. પ્રારંભમાં, નમૂનાઓમાં સમાન સંખ્યાના ન્યૂક્લિયસોની સંખ્યા ધારતા, 60 મિનિટ બાદ, A અને B ન્યૂક્લિયસોમાંથી ક્ષયપામતા ન્યૂક્લિયસોનો ગુણોત્તર _____ થશે.

Options :

1. 1 : 8
2. 9 : 8
3. 8 : 1
4. 3 : 8

Question Number : 27 Question Type : MCQ Option Shuffling : Yes Display Question Number : Yes Single Line Question Option : No Option Orientation : Vertical

Correct Marks : 4 Wrong Marks : 1

Figure shows a DC voltage regulator circuit, with a Zener diode of breakdown voltage = 6V. If the unregulated input voltage varies between 10 V to 16 V, then what is the maximum Zener current ?

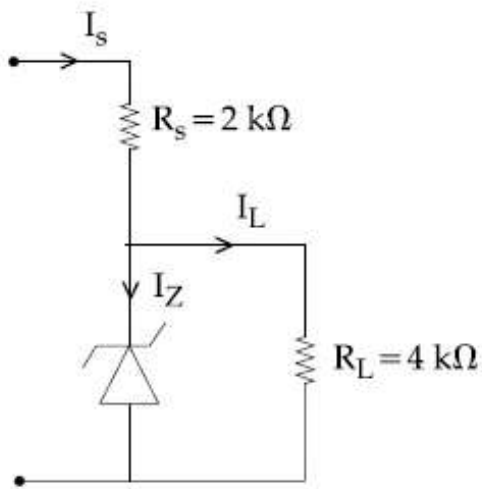

Options :

1. 7.5 mA
2. 1.5 mA
3. 2.5 mA
4. 3.5 mA

Question Number : 27 Question Type : MCQ Option Shuffling : Yes Display Question Number : Yes Single Line Question Option : No Option Orientation : Vertical

Correct Marks : 4 Wrong Marks : 1

चित्र में भंजन वोल्टता = 6V के जेनर डायोड से बनाया विद्युत नियंत्रक परिपथ दिखाया है। यदि अनियंत्रित निवेशित विभव 10 V तथा 16 V के बीच बदलता है तो जेनर डायोड में अधिकतम धारा का मान होगा :

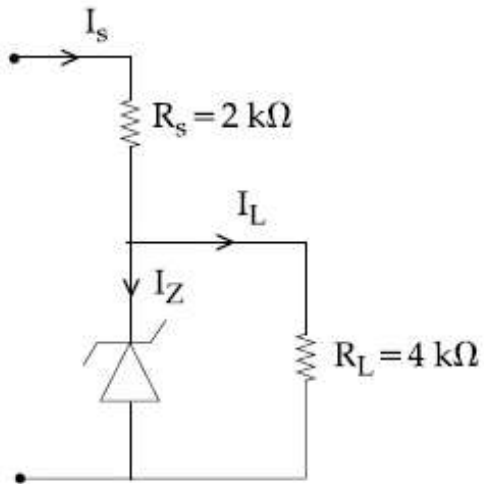

Options :

1. 7.5 mA
2. 1.5 mA
3. 2.5 mA
4. 3.5 mA

Question Number : 27 Question Type : MCQ Option Shuffling : Yes Display Question Number : Yes Single Line Question Option : No Option Orientation : Vertical

Correct Marks : 4 Wrong Marks : 1

6V જેટલો પ્રેકડાઉન વોલ્ટેજ ધરાવતા ઝેનર ડાયોડથી બનેલો એક DC વોલ્ટેજ રેગ્યુલેટર (નિયામક) પરિપથ આકૃતિમાં દર્શાવેલ છે. જો unregulated (અનિયામક) ઇનપુટ વોલ્ટેજ 10 V અને 16 V ની વચ્ચે બદલાતો હોય તો મહત્તમ ઝેનર પ્રવાહ કેટલો હશે?

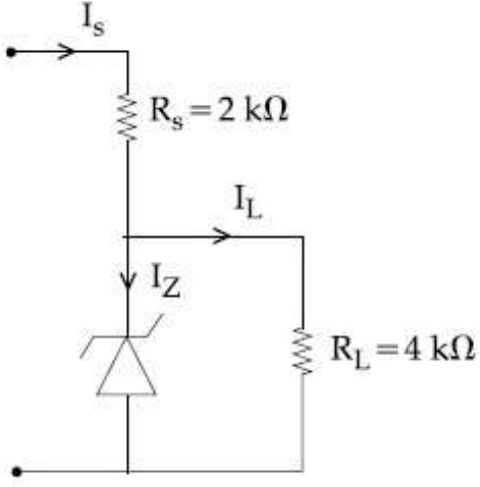

Options :

1. 7.5 mA
2. 1.5 mA
3. 2.5 mA
4. 3.5 mA

Question Number : 28 Question Type : MCQ Option Shuffling : Yes Display Question Number : Yes Single Line Question Option : No Option Orientation : Vertical

Correct Marks : 4 Wrong Marks : 1

In an amplitude modulator circuit, the carrier wave is given by,

$C(t) = 4 \sin(20000 \pi t)$ while modulating signal is given by, $m(t) = 2 \sin(2000 \pi t)$. The values of modulation index and lower side band frequency are :

Options :

1. 0.3 and 9 kHz
2. 0.4 and 10 kHz
3. 0.5 and 10 kHz

4. 0.5 and 9 kHz

Question Number : 28 Question Type : MCQ Option Shuffling : Yes Display Question Number : Yes Single Line Question Option : No Option Orientation : Vertical

Correct Marks : 4 Wrong Marks : 1

एक आयामी मॉड्युलन परिपथ में निवेशी वाहक तरंग $C(t) = 4 \sin(20000 \pi t)$ है, जबकि मॉड्युलन सिग्नल $m(t) = 2 \sin(2000 \pi t)$ है। मॉड्युलन सूचकांक तथा निचली पार्श्व बैंड आवृत्ति के मान होंगे :

Options :

1. 0.3 तथा 9 kHz
2. 0.4 तथा 10 kHz
3. 0.5 तथा 10 kHz
4. 0.5 तथा 9 kHz

Question Number : 28 Question Type : MCQ Option Shuffling : Yes Display Question Number : Yes Single Line Question Option : No Option Orientation : Vertical

Correct Marks : 4 Wrong Marks : 1

એક એમ્પ્લિટ્યૂડ (કંપવિસ્તાર) માડ્યુલેટર પરિપથમાં, કેરિયર તરંગ $C(t) = 4 \sin(20000 \pi t)$ વડે જ્યારે માડ્યુલેટિંગ સિગ્નલ $m(t) = 2 \sin(2000 \pi t)$ વડે આપવામાં આવે છે. માડ્યુલેશન અંક અને નિમ્ન (lower) સાઇડબેન્ડ ની આવૃત્તિ :

Options :

1. 0.3 અને 9 kHz
2. 0.4 અને 10 kHz
3. 0.5 અને 10 kHz
4. 0.5 અને 9 kHz

Question Number : 29 Question Type : MCQ Option Shuffling : Yes Display Question Number : Yes Single Line Question Option : No Option Orientation : Vertical

Correct Marks : 4 Wrong Marks : 1

A tuning fork of frequency 480 Hz is used in an experiment for measuring speed of sound (v) in air by resonance tube method. Resonance is observed to occur at two successive lengths of the air column, $l_1 = 30$ cm and $l_2 = 70$ cm. Then, v is equal to :

Options :

1. 338 ms^{-1}
2. 379 ms^{-1}
3. 384 ms^{-1}
4. 332 ms^{-1}

Question Number : 29 Question Type : MCQ Option Shuffling : Yes Display Question Number : Yes Single Line Question Option : No Option Orientation : Vertical

Correct Marks : 4 Wrong Marks : 1

अनुनाद नली विधि द्वारा वायु में ध्वनि की चाल (v) ज्ञात करने के लिये एक प्रयोग में 480 Hz आवृत्ति के स्वरित्र का उपयोग करते हैं। वायु स्तम्भ की दो उत्तरोत्तर लम्बाइयों $l_1 = 30$ cm तथा $l_2 = 70$ cm के लिये अनुनाद प्राप्त होते हैं। तब v का मान है :

Options :

1. 338 ms^{-1}
2. 379 ms^{-1}
3. 384 ms^{-1}
4. 332 ms^{-1}

Question Number : 29 Question Type : MCQ Option Shuffling : Yes Display Question Number : Yes Single Line Question Option : No Option Orientation : Vertical

Correct Marks : 4 Wrong Marks : 1

अनुनाद नली-रीतथी लवामां ध्वनिनी ञऽप (v) मापवानां अेक प्रयोगमां वापरवामां आवेल ध्वनि थीपीयानी आवृत्ति 480 Hz ऐ. ँे कृमिक आवत्ता $l_1 = 30$ cm अने $l_2 = 70$ cm संभाईना लवाना स्तंभोमाटे अनुनाद जेवा मजे ऐ. तो v _____ थशे.

Options :

1. 338 ms^{-1}
2. 379 ms^{-1}
3. 384 ms^{-1}
4. 332 ms^{-1}

Question Number : 30 Question Type : MCQ Option Shuffling : Yes Display Question Number : Yes Single Line Question Option : No Option Orientation : Vertical

Correct Marks : 4 Wrong Marks : 1

A moving coil galvanometer, having a resistance G , produces full scale deflection when a current I_g flows through it. This galvanometer can be converted into (i) an ammeter of range 0 to I_0 ($I_0 > I_g$) by connecting a shunt resistance R_A to it and (ii) into a voltmeter of range 0 to V ($V = GI_0$) by connecting a series resistance R_V to it. Then,

Options :

1. $R_A R_V = G^2$ and $\frac{R_A}{R_V} = \left(\frac{I_g}{I_0 - I_g} \right)^2$

2. $R_A R_V = G^2$ and $\frac{R_A}{R_V} = \frac{I_g}{(I_0 - I_g)}$

3. $R_A R_V = G^2 \left(\frac{I_g}{I_0 - I_g} \right)$ and

3. $\frac{R_A}{R_V} = \left(\frac{I_0 - I_g}{I_g} \right)^2$

4. $R_A R_V = G^2 \left(\frac{I_0 - I_g}{I_g} \right)$ and

4. $\frac{R_A}{R_V} = \left(\frac{I_g}{(I_0 - I_g)} \right)^2$

Correct Marks : 4 Wrong Marks : 1

પ્રતિરોધ G કે એક ચલ કુંડલી ધારામાપી મેં ધારા I_g પર પૂર્ણ વિક્ષેપ પાયા જાતા હૈ। ઇસ ધારામાપી કો પરાસ 0 સે I_0 ($I_0 > I_g$) ધારા કે અમીટર મેં એક શંટ પ્રતિરોધ R_A લગાકર પરિવર્તિત કર સકતે હૈ। ઇસી ધારામાપી કો પરાસ 0 સે V ($V = GI_0$) કે વોલ્ટમીટર મેં એક શ્રેણી પ્રતિરોધ R_V લગાકર પરિવર્તિત કર સકતે હૈ। તો :

Options :

1. $R_A R_V = G^2$ તથા $\frac{R_A}{R_V} = \left(\frac{I_g}{I_0 - I_g} \right)^2$

2. $R_A R_V = G^2$ તથા $\frac{R_A}{R_V} = \frac{I_g}{(I_0 - I_g)}$

3. $R_A R_V = G^2 \left(\frac{I_g}{I_0 - I_g} \right)$ તથા

3. $\frac{R_A}{R_V} = \left(\frac{I_0 - I_g}{I_g} \right)^2$

4. $R_A R_V = G^2 \left(\frac{I_0 - I_g}{I_g} \right)$ તથા

4. $\frac{R_A}{R_V} = \left(\frac{I_g}{(I_0 - I_g)} \right)^2$

Correct Marks : 4 Wrong Marks : 1

G જેટલો અવરોધ ધરાવતા એક ચલિત ગૂંચળાવાળા ગેલ્વેનોમીટરમાં I_g જેટલો પ્રવાહ પસાર કરતા પૂર્ણ સ્કેલ આવર્તન આપે છે. આ ગેલ્વેનોમીટરને (i) R_A જેટલો શંટ (લઘુ અવરોધ) જોડી 0 થી I_0 ($I_0 > I_g$) અવધી (રેંજ) ધરાવતા એમીટરમાં અને (ii) R_V જેટલો શ્રેણી અવરોધ જોડી 0 થી V ($V = GI_0$) રેંજ ધરાવતા વોલ્ટમીટરમાં રૂપાંતરિત કરી શકાય છે. તો _____.

Options :

1. $R_A R_V = G^2 \Rightarrow \frac{R_A}{R_V} = \left(\frac{I_g}{I_0 - I_g} \right)^2$

2. $R_A R_V = G^2 \Rightarrow \frac{R_A}{R_V} = \frac{I_g}{(I_0 - I_g)}$

$R_A R_V = G^2 \left(\frac{I_g}{I_0 - I_g} \right) \Rightarrow$

3. $\frac{R_A}{R_V} = \left(\frac{I_0 - I_g}{I_g} \right)^2$

$R_A R_V = G^2 \left(\frac{I_0 - I_g}{I_g} \right) \Rightarrow$

4. $\frac{R_A}{R_V} = \left(\frac{I_g}{(I_0 - I_g)} \right)^2$

Section Id :	Chemistry
Section Number :	416529278
Section type :	2
Mandatory or Optional:	Online
Number of Questions:	Mandatory
Number of Questions to be attempted:	30
Section Marks:	30
Display Number Panel:	120
Group All Questions:	Yes
	No

Sub-Section Number:	1
Sub-Section Id:	416529418
Question Shuffling Allowed :	Yes

Question Number : 31 Question Type : MCQ Option Shuffling : Yes Display Question Number : Yes Single Line Question Option : No Option Orientation : Vertical Correct Marks : 4 Wrong Marks : 1

In the following skew conformation of ethane, $H' - C - C - H''$ dihedral angle is :

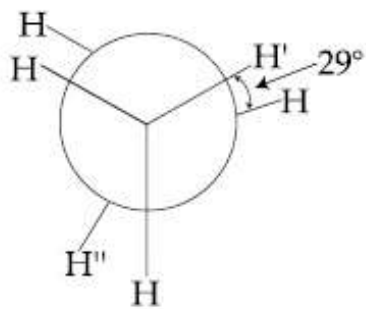

Options :

1. 58°
2. 151°
3. 149°
4. 120°

Question Number : 31 Question Type : MCQ Option Shuffling : Yes Display Question Number : Yes Single Line Question Option : No Option Orientation : Vertical

Correct Marks : 4 Wrong Marks : 1

एथेन के निम्न विषमतलीय संरूपण में,
 $H' - C - C - H''$ द्वितल कोण है :

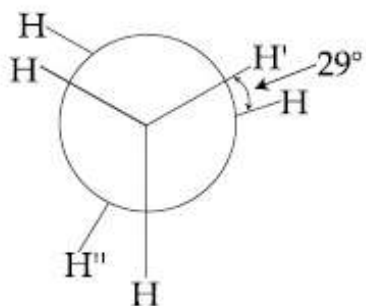

Options :

1. 58°
2. 151°
3. 149°
4. 120°

Question Number : 31 Question Type : MCQ Option Shuffling : Yes Display Question Number : Yes Single Line Question Option : No Option Orientation : Vertical

Correct Marks : 4 Wrong Marks : 1

ઈથેનના નીચે આપેલા સક્યુ સંરૂપી માટે,
 $H-C-C-H$ દ્વિતલ (ગ્રઈહાઈડ્રલ) કોણ છે :

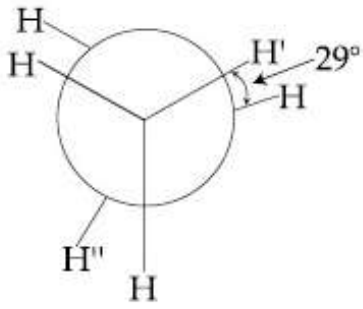

Options :

1. 58°
2. 151°
3. 149°
4. 120°

Question Number : 32 Question Type : MCQ Option Shuffling : Yes Display Question Number : Yes Single Line Question Option : No Option Orientation : Vertical

Correct Marks : 4 Wrong Marks : 1

The IUPAC name for the following compound is :

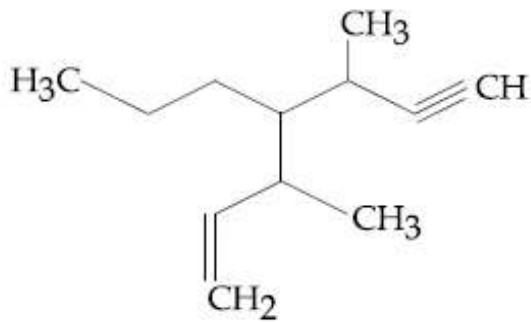

Options :

1. 3,5-dimethyl-4-propylhept-6-en-1-yne
2. 3-methyl-4-(3-methylprop-1-enyl)-1-heptyne
3. 3,5-dimethyl-4-propylhept-1-en-6-yne

4. 3-methyl-4-(1-methylprop-2-ynyl)-1-heptene

Question Number : 32 Question Type : MCQ Option Shuffling : Yes Display Question Number : Yes Single Line Question Option : No Option Orientation : Vertical

Correct Marks : 4 Wrong Marks : 1

निम्न यौगिक के लिए IUPAC नाम है :

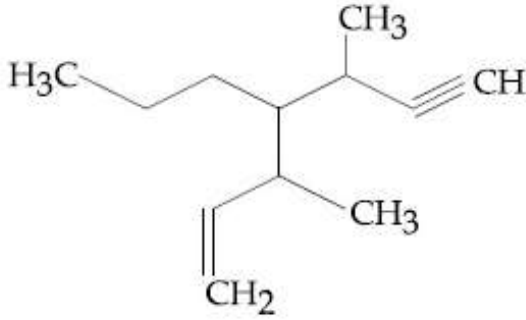

Options :

1. 3,5-डाइमेथिल-4-प्रोपिलहेप्ट-6-ईन-1-आइन
2. 3-मेथिल-4-(3-मेथिलप्रोप-1-इनिल)-1-हेप्टाइन
3. 3,5-डाइमेथिल-4-प्रोपिलहेप्ट-1-ईन-6-आइन
4. 3-मेथिल-4-(1-मेथिलप्रोप-2-आयनिल)-1-हेप्टीन

Question Number : 32 Question Type : MCQ Option Shuffling : Yes Display Question Number : Yes Single Line Question Option : No Option Orientation : Vertical

Correct Marks : 4 Wrong Marks : 1

નીચે આપેલા સંયોજનનું IUPAC નામ છે :

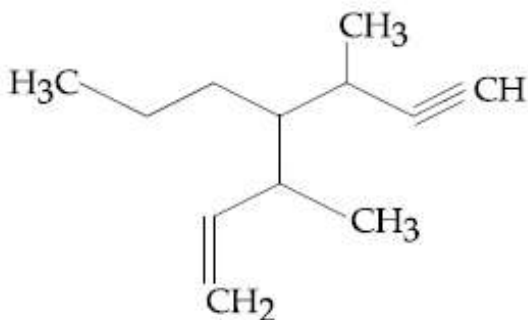

Options :

3,5-ડાઈમિથાઈલ-4-પ્રોપાઈલહેપ્ટ-6-ઈન-1-

1. આઈન

3-મિથાઈલ-4-(3-મિથાઈલપ્રોપ-1-ઈનાઈલ)-

2. 1-હેપ્ટાઈન

3,5-ડાઈમિથાઈલ-4-પ્રોપીલહેપ્ટ-1-ઈન-6-

3. આઈન

3-મિથાઈલ-4-(1-મિથાઈલપ્રોપ-2-

4. વાયનાઈલ)-1-હેપ્ટીન

Question Number : 33 Question Type : MCQ Option Shuffling : Yes Display Question Number : Yes Single Line Question Option : No Option Orientation : Vertical

Correct Marks : 4 Wrong Marks : 1

Consider the following reactions :

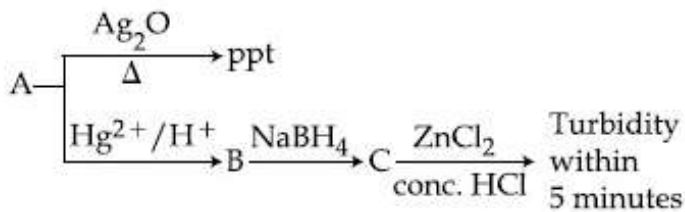

'A' is :

Options :

1. $\text{CH} \equiv \text{CH}$

2. $\text{CH}_3 - \text{C} \equiv \text{CH}$

3. $\text{CH}_3 - \text{C} \equiv \text{C} - \text{CH}_3$

4. $\text{CH}_2 = \text{CH}_2$

Question Number : 33 Question Type : MCQ Option Shuffling : Yes Display Question Number : Yes Single Line Question Option : No Option Orientation : Vertical

Correct Marks : 4 Wrong Marks : 1

निम्न अभिक्रियाओं पर विचार कीजिए :

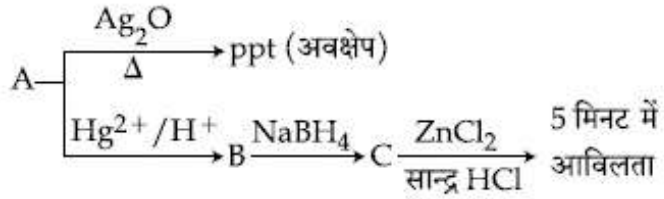

'A' है :

Options :

1. $\text{CH} \equiv \text{CH}$
2. $\text{CH}_3 - \text{C} \equiv \text{CH}$
3. $\text{CH}_3 - \text{C} \equiv \text{C} - \text{CH}_3$
4. $\text{CH}_2 = \text{CH}_2$

Question Number : 33 Question Type : MCQ Option Shuffling : Yes Display Question Number : Yes Single Line Question Option : No Option Orientation : Vertical

Correct Marks : 4 Wrong Marks : 1

નીચેની પ્રક્રિયાને ધ્યાનમાં લો :

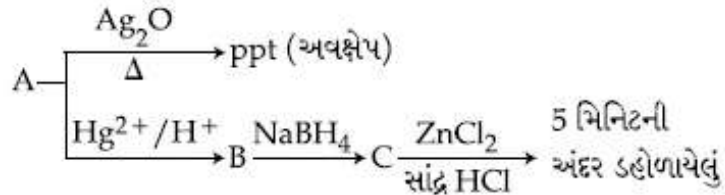

'A' છે :

Options :

1. $\text{CH} \equiv \text{CH}$
2. $\text{CH}_3 - \text{C} \equiv \text{CH}$
3. $\text{CH}_3 - \text{C} \equiv \text{C} - \text{CH}_3$
4. $\text{CH}_2 = \text{CH}_2$

Question Number : 34 Question Type : MCQ Option Shuffling : Yes Display Question Number : Yes Single Line Question Option : No Option Orientation : Vertical

Correct Marks : 4 Wrong Marks : 1

Which of the given statements is INCORRECT about glycogen ?

Options :

1. It is present in animal cells.
2. It is a straight chain polymer similar to amylose.
3. It is present in some yeast and fungi.
4. Only α -linkages are present in the molecule.

Question Number : 34 Question Type : MCQ Option Shuffling : Yes Display Question Number : Yes Single Line Question Option : No Option Orientation : Vertical

Correct Marks : 4 Wrong Marks : 1

ग्लायकोजेन के सम्बन्ध में दिये गये कथनों में से कौन सा सही नहीं है?

Options :

1. यह प्राणी-कोषिकाओं में उपस्थित है।
2. एमिलोज की तरह यह एक ऋजुशृंखल बहुलक है।
3. यह कुछ यीस्ट (खमीर) तथा कवकों में उपस्थित है।
4. अणुओं में मात्र α -बंधनें उपस्थित हैं।

Question Number : 34 Question Type : MCQ Option Shuffling : Yes Display Question Number : Yes Single Line Question Option : No Option Orientation : Vertical

Correct Marks : 4 Wrong Marks : 1

ग्लायकोजन माटे आपेला विधानो पैकी क्यु सायु नथी?

Options :

1. એ પ્રાણીના કોષમાં હાજર છે.
2. એ એમાયલોજના જેવો એક સીધી શૃંખલા ધરાવતો બહુલક છે.
3. તે અમુક યીસ્ટ અને ફુગમાં હાજર છે.
4. આણુમાં ફક્ત α -કડીઓ હાજર છે.

Question Number : 35 Question Type : MCQ Option Shuffling : Yes Display Question Number : Yes Single Line Question Option : No Option Orientation : Vertical

Correct Marks : 4 Wrong Marks : 1

The correct name of the following polymer is :

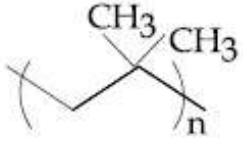

Options :

1. Polyisobutane
2. Polyisobutylene
3. Polytert-butylene
4. Polyisoprene

Question Number : 35 Question Type : MCQ Option Shuffling : Yes Display Question Number : Yes Single Line Question Option : No Option Orientation : Vertical

Correct Marks : 4 Wrong Marks : 1

निम्न बहुलक का सही नाम है :

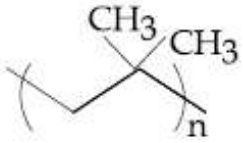

Options :

1. पालीआइसोब्यूटेन
2. पालीआइसोब्यूटाइलीन
3. पालीटर्ट-ब्यूटाइलीन
4. पालीआइसोप्रीन

Question Number : 35 Question Type : MCQ Option Shuffling : Yes Display Question Number : Yes Single Line Question Option : No Option Orientation : Vertical

Correct Marks : 4 Wrong Marks : 1

નીચેના બહુલકનું સાચું નામ છે :

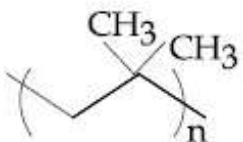

Options :

1. पोलीआइसोप्युटेन
2. पोलीआइसोप्युटीलीन
3. पोलीटैट-प्युटीलीन
4. पोलीआइसोप्रीन

Question Number : 36 Question Type : MCQ Option Shuffling : Yes Display Question Number : Yes Single Line Question Option : No Option Orientation : Vertical

Correct Marks : 4 Wrong Marks : 1

Benzene diazonium chloride on reaction with aniline in the presence of dilute hydrochloric acid gives :

Options :

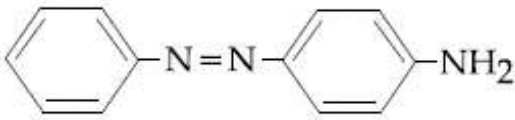
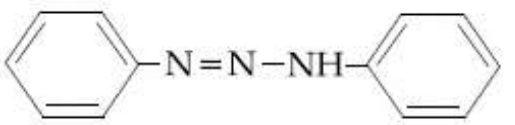
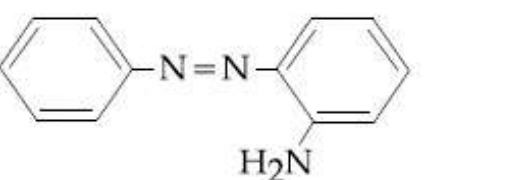
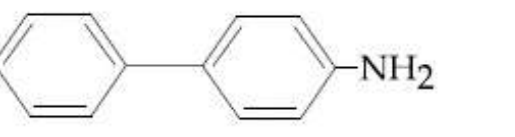
1. 
2. 
3. 
4. 

Question Number : 36 Question Type : MCQ Option Shuffling : Yes Display Question Number : Yes Single Line Question Option : No Option Orientation : Vertical

Correct Marks : 4 Wrong Marks : 1

तनु हाइड्रोक्लोरिक अम्ल की उपस्थिति में बेंजीन डाइजोनियम क्लोराइड, एनिलीन के साथ अभिक्रिया करके देता है :

Options :

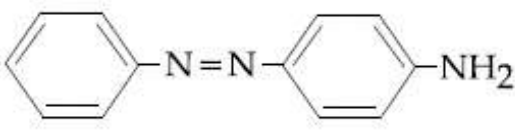
1. 

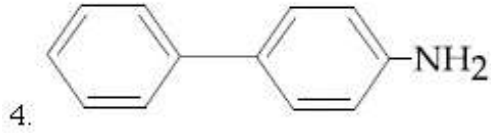
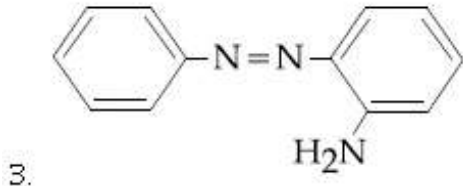
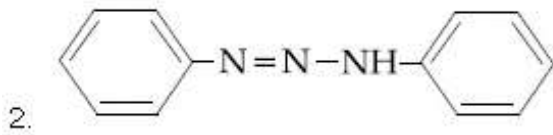

Question Number : 36 Question Type : MCQ Option Shuffling : Yes Display Question Number : Yes Single Line Question Option : No Option Orientation : Vertical

Correct Marks : 4 Wrong Marks : 1

મંદ હાઇડ્રોકલોરીક એસિડની હાજરીમાં બેન્ઝિન ડાઇએઝોનિયમ ક્લોરાઇડની એનીલીન સાથે પ્રક્રિયા કરતા મળે છે.

Options :

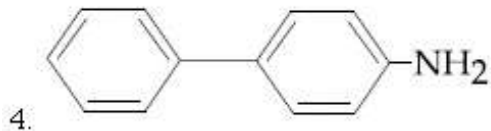
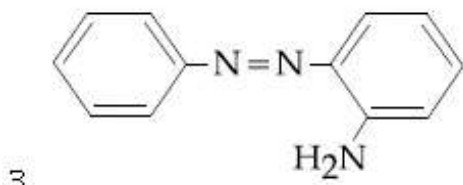
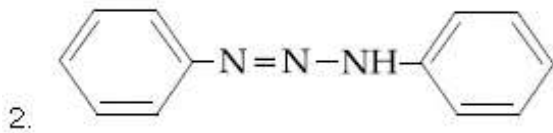
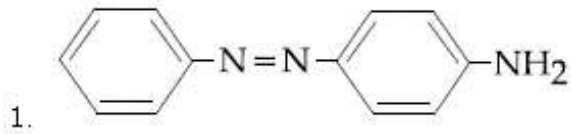

Question Number : 37 Question Type : MCQ Option Shuffling : Yes Display Question Number : Yes Single Line Question Option : No Option Orientation : Vertical

Correct Marks : 4 Wrong Marks : 1

Heating of 2-chloro-1-phenylbutane with EtOK/EtOH gives X as the major product. Reaction of X with $\text{Hg}(\text{OAc})_2/\text{H}_2\text{O}$ followed by NaBH_4 gives Y as the major product. Y is :

Options :

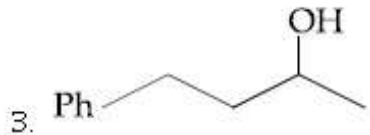
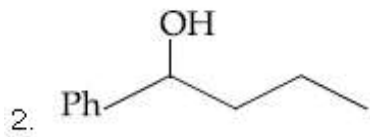
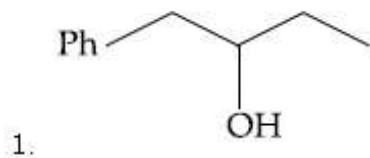

Question Number : 37 Question Type : MCQ Option Shuffling : Yes Display Question Number : Yes Single Line Question Option : No Option Orientation : Vertical

Correct Marks : 4 Wrong Marks : 1

2-क्लोरो-1-फेनिलब्यूटेन को EtOK/EtOH के साथ गरम करने पर X मुख्य उत्पाद के रूप में प्राप्त होता है। Hg(OAc)₂/H₂O के साथ X की अभिक्रिया तत्पश्चात् NaBH₄ के साथ अभिक्रिया से प्राप्त Y मुख्य उत्पाद है। Y है :

Options :

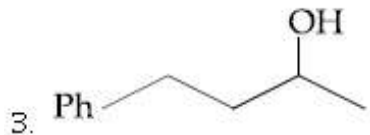
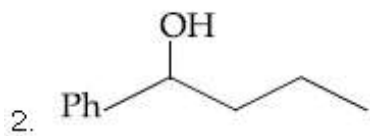
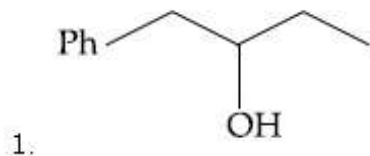

Question Number : 37 Question Type : MCQ Option Shuffling : Yes Display Question Number : Yes Single Line Question Option : No Option Orientation : Vertical

Correct Marks : 4 Wrong Marks : 1

2-ક્લોરો-1-ફિનાઇલબ્યુટેનને EtOK/EtOH ની સાથે ગરમ કરતા મળતી મુખ્ય નીપજ X છે. X ની Hg(OAc)₂/H₂O સાથે પ્રક્રિયા કર્યા બાદ NaBH₄ સાથે પ્રક્રિયા કરતા Y મુખ્ય નીપજ આપે છે તો Y એ :

Options :

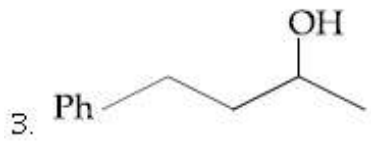
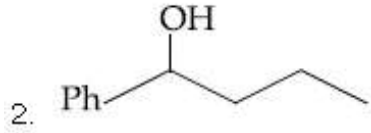
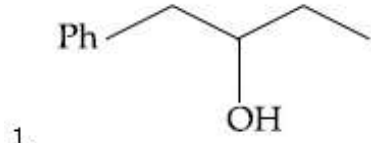

Question Number : 38 Question Type : MCQ Option Shuffling : Yes Display Question Number : Yes Single Line Question Option : No Option Orientation : Vertical

Correct Marks : 4 Wrong Marks : 1

What will be the major product when m-cresol is reacted with propargyl bromide (HC≡C-CH₂Br) in presence of K₂CO₃ in acetone ?

Options :

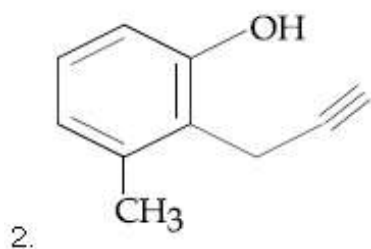
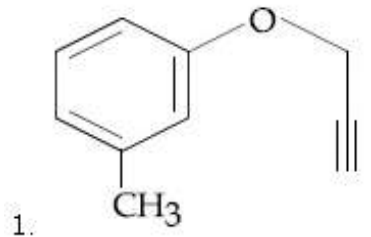

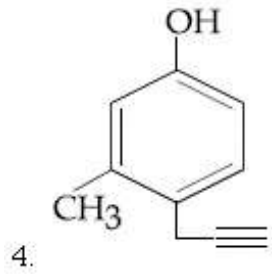
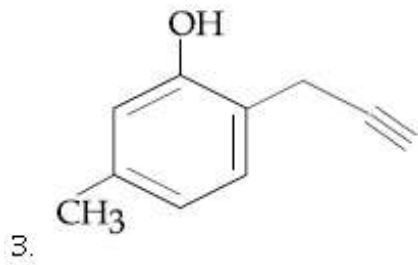

Question Number : 38 Question Type : MCQ Option Shuffling : Yes Display Question Number : Yes Single Line Question Option : No Option Orientation : Vertical

Correct Marks : 4 Wrong Marks : 1

मुख्य उत्पाद क्या होगा जब m-क्रिसॉल को एसीटोन में K_2CO_3 की उपस्थिति में प्रोपर्जिल ब्रोमाइड ($HC \equiv C-CH_2Br$) के साथ अभिकृत किया जाता है?

Options :

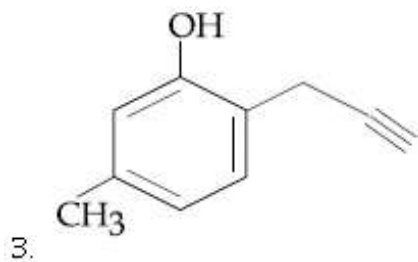
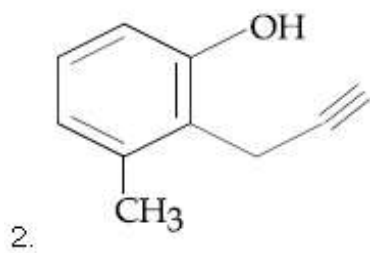
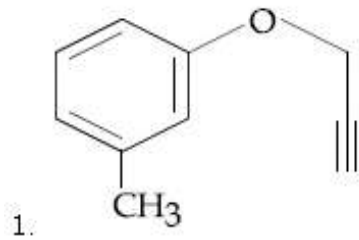

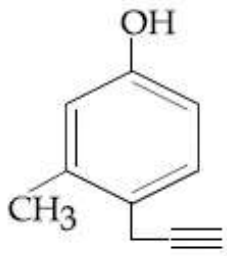

Question Number : 38 Question Type : MCQ Option Shuffling : Yes Display Question Number : Yes Single Line Question Option : No Option Orientation : Vertical

Correct Marks : 4 Wrong Marks : 1

એસિટોનમાં K_2CO_3 ની હાજરીમાં m-કેસોલની પ્રોપેગાઇલ બ્રોમાઇડ ($HC \equiv C-CH_2Br$) ની સાથે પ્રક્રિયા કરતા મુખ્ય નીપજ શું હશે?

Options :

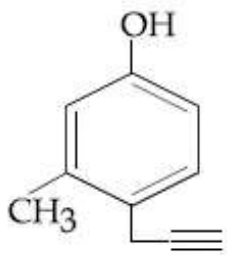
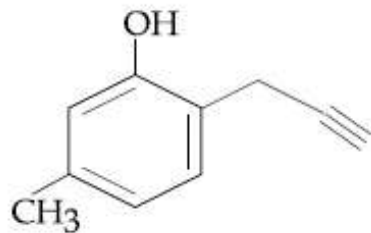
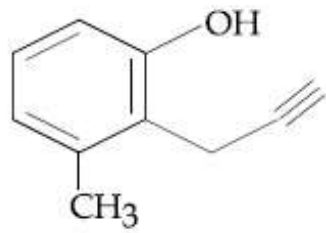
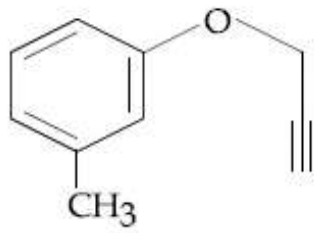

Question Number : 39 Question Type : MCQ Option Shuffling : Yes Display Question Number : Yes Single Line Question Option : No Option Orientation : Vertical

Correct Marks : 4 Wrong Marks : 1

An 'Assertion' and a 'Reason' are given below. Choose the correct answer from the following options :

Assertion (A): Vinyl halides do not undergo nucleophilic substitution easily.

Reason (R): Even though the intermediate carbocation is stabilized by loosely held π -electrons, the cleavage is difficult because of strong bonding.

Options :

1. Both (A) and (R) are correct statements and (R) is the correct explanation of (A).
2. Both (A) and (R) are correct statements but (R) is not the correct explanation of (A).
3. (A) is a correct statement but (R) is a wrong statement.
4. Both (A) and (R) are wrong statements.

Question Number : 39 Question Type : MCQ Option Shuffling : Yes Display Question Number : Yes Single Line Question Option : No Option Orientation : Vertical

Correct Marks : 4 Wrong Marks : 1

एक 'कथन' तथा एक 'कारण' नीचे दिया गया है।

निम्न विकल्पों में से सही उत्तर का चुनाव कीजिए :

कथन (A) : विनाइल हैलाइड का नाभिकरागी प्रतिस्थापन आसानी से नहीं होता।

कारण (R) : अदृढ़ π -इलेक्ट्रॉनों द्वारा मध्यवर्ती कार्बोकैटायन के स्थायित्व के बावजूद भी, प्रबल आबंधन के कारण विदलन कठिन है।

Options :

1. (A) तथा (R) दोनों सही हैं तथा (R), (A) की सही व्याख्या है।
2. (A) तथा (R) दोनों सही हैं परन्तु (R), (A) की सही व्याख्या नहीं है।

3. (A) सही है परन्तु (R) गलत है।

4. (A) तथा (R) दोनों ही गलत हैं।

Question Number : 39 Question Type : MCQ Option Shuffling : Yes Display Question Number : Yes Single Line Question Option : No Option Orientation : Vertical

Correct Marks : 4 Wrong Marks : 1

નીચે 'અભિધારણા' અને 'કારણ' આપેલા છે નીચે આપેલા વિકલ્પો પૈકી સાચો જવાબ પસંદ કરો.

અભિધારણા (A) : વિનાઇલ હેલાઈડો કેન્દ્ર સ્નેહી પ્રતિસ્થાપન અભિક્રિયા સહેલાય થી કરતા નથી.

કારણ (R) : માધ્યમિક સંયોજન કાર્બોકેટાયન નિર્બળ રીતે જોડાયેલા π ઇલેક્ટ્રોન્સથી સ્થાયી હોવા છતા મજબૂત બંધાણના કારણે વિદલન (cleavage) મુશ્કેલ છે.

Options :

1. (A) અને (R) બંને સાચા વિધાનો છે અને (R) એ (A) ની સાચી સમજૂતી છે.

2. (A) અને (R) બંને સાચા વિધાનો છે અને (R) એ (A) ની સાચી સમજૂતી નથી.

3. વિધાન (A) સાચુ છે, પણ (R) ખોટું છે.

4. (A) અને (R) બંને ખોટા વિધાનો છે.

Question Number : 40 Question Type : MCQ Option Shuffling : Yes Display Question Number : Yes Single Line Question Option : No Option Orientation : Vertical

Correct Marks : 4 Wrong Marks : 1

Which one of the following is likely to give a precipitate with AgNO_3 solution ?

Options :

1. CCl_4

2. CHCl_3

3. $(\text{CH}_3)_3\text{CCl}$

4. $\text{CH}_2=\text{CH}-\text{Cl}$

Question Number : 40 Question Type : MCQ Option Shuffling : Yes Display Question Number : Yes Single Line Question Option : No Option Orientation : Vertical

Correct Marks : 4 Wrong Marks : 1

निम्न में से किसकी AgNO_3 विलयन के साथ अवक्षेप देने की संभावना है?

Options :

1. CCl_4
2. CHCl_3
3. $(\text{CH}_3)_3\text{CCl}$
4. $\text{CH}_2=\text{CH}-\text{Cl}$

Question Number : 40 Question Type : MCQ Option Shuffling : Yes Display Question Number : Yes Single Line Question Option : No Option Orientation : Vertical

Correct Marks : 4 Wrong Marks : 1

AgNO_3 ना द्रावणनी साथे नीचेना पैकी क्युं अक अवक्षेप आपी शके?

Options :

1. CCl_4
2. CHCl_3
3. $(\text{CH}_3)_3\text{CCl}$
4. $\text{CH}_2=\text{CH}-\text{Cl}$

Question Number : 41 Question Type : MCQ Option Shuffling : Yes Display Question Number : Yes Single Line Question Option : No Option Orientation : Vertical

Correct Marks : 4 Wrong Marks : 1

In comparison to boron, beryllium has :

Options :

1. greater nuclear charge and greater first ionisation enthalpy.
2. lesser nuclear charge and greater first ionisation enthalpy.
3. lesser nuclear charge and lesser first ionisation enthalpy.

greater nuclear charge and lesser first
ionisation enthalpy.

4.

Question Number : 41 Question Type : MCQ Option Shuffling : Yes Display Question Number : Yes Single Line Question Option :
No Option Orientation : Vertical

Correct Marks : 4 Wrong Marks : 1

बोरान की तुलना में बेरीलियम रखता है :

Options :

1. उच्चतर नाभिकीय आवेश तथा उच्चतर प्रथम आयनन एन्थैल्पी।
2. निम्नतर नाभिकीय आवेश तथा उच्चतर प्रथम आयनन एन्थैल्पी।
3. निम्नतर नाभिकीय आवेश तथा निम्नतर प्रथम आयनन एन्थैल्पी।
4. उच्चतर नाभिकीय आवेश तथा निम्नतर प्रथम आयनन एन्थैल्पी।

Question Number : 41 Question Type : MCQ Option Shuffling : Yes Display Question Number : Yes Single Line Question Option :
No Option Orientation : Vertical

Correct Marks : 4 Wrong Marks : 1

બોરોન ની સરખામણીમાં બેરીલિયમ પાસે, :

Options :

1. વધુ ન્યુક્લીયર ભાર અને વધુ પ્રથમ આયનીકરણ એન્થાલ્પી
2. ઓછો ન્યુક્લીયર ભાર અને વધુ પ્રથમ આયનીકરણ એન્થાલ્પી
3. ઓછો ન્યુક્લીયર ભાર અને ઓછી પ્રથમ આયનીકરણ એન્થાલ્પી
4. વધુ ન્યુક્લીયર ભાર અને ઓછી પ્રથમ આયનીકરણ એન્થાલ્પી

Question Number : 42 Question Type : MCQ Option Shuffling : Yes Display Question Number : Yes Single Line Question Option :
No Option Orientation : Vertical

Correct Marks : 4 Wrong Marks : 1

The correct statement is :

Options :

1. the blistered appearance of copper during the metallurgical process is due to the evolution of CO_2 .

2. pig iron is obtained from cast iron.

3. leaching of bauxite using concentrated NaOH solution gives sodium aluminate and sodium silicate.

4. the Hall-Heroult process is used for the production of aluminium and iron.

Question Number : 42 Question Type : MCQ Option Shuffling : Yes Display Question Number : Yes Single Line Question Option : No Option Orientation : Vertical

Correct Marks : 4 Wrong Marks : 1

सही कथन है :

Options :

1. धात्विक प्रक्रम के बीच कॉपर का ब्लिस्टर्ड रूप CO_2 के निर्गमन के कारण होता है।

2. कास्ट आयरन (ढलवालोहा) से पिग आयरन(कच्चा लोहा) प्राप्त किया जाता है।

3. सान्द्र NaOH विलयन का प्रयोग करते हुये बाक्साइट का निक्षालन सोडियम एलुमीनेट तथा सोडियम सिलीकेट देता है।

4. एलुमीनियम तथा आयरन के उत्पादन के लिए हाल-हेराल्ट प्रक्रम प्रयुक्त होता है।

Question Number : 42 Question Type : MCQ Option Shuffling : Yes Display Question Number : Yes Single Line Question Option : No Option Orientation : Vertical

Correct Marks : 4 Wrong Marks : 1

સાચું વિધાન છે :

Options :

1. ધાત્વીક્રીય પદ્ધતિમાં તાંબાનો ઉત્સર્જોટિતીય દેખાવ CO_2 ઉત્પન્ન થવાના સિધે છે.

2. કચુ લોખંડ એ ઢાળેલા લોખંડમાંથી મળે છે.

બોક્સાઇટનું સાન્દ્ર NaOH માં દ્રાવણ વડે પ્રવાહીત નિક્ષાલન કરતા સોડિયમ એલ્યુમિનેટ અને સોડિયમ સિલીકેટ આપે છે.

4. હોલ-હેરાલ્ડ પદ્ધતી એલ્યુમિનિયમ અને લોખંડના ઉત્પાદનમાં વપરાય છે.

Question Number : 43 Question Type : MCQ Option Shuffling : Yes Display Question Number : Yes Single Line Question Option : No Option Orientation : Vertical

Correct Marks : 4 Wrong Marks : 1

The temporary hardness of a water sample is due to compound X. Boiling this sample converts X to compound Y. X and Y, respectively, are :

Options :

1. $Mg(HCO_3)_2$ and $Mg(OH)_2$
2. $Mg(HCO_3)_2$ and $MgCO_3$
3. $Ca(HCO_3)_2$ and $Ca(OH)_2$
4. $Ca(HCO_3)_2$ and CaO

Question Number : 43 Question Type : MCQ Option Shuffling : Yes Display Question Number : Yes Single Line Question Option : No Option Orientation : Vertical

Correct Marks : 4 Wrong Marks : 1

जल प्रतिदर्श की अस्थायी कठोरता यौगिक X के कारण है। इस प्रतिदर्श को उबालने पर X बदलकर यौगिक Y हो जाता है। X तथा Y, क्रमशः, हैं :

Options :

1. $Mg(HCO_3)_2$ तथा $Mg(OH)_2$
2. $Mg(HCO_3)_2$ तथा $MgCO_3$
3. $Ca(HCO_3)_2$ तथा $Ca(OH)_2$
4. $Ca(HCO_3)_2$ तथा CaO

Question Number : 43 Question Type : MCQ Option Shuffling : Yes Display Question Number : Yes Single Line Question Option : No Option Orientation : Vertical

Correct Marks : 4 Wrong Marks : 1

પાણીના નમૂનાની અસ્થાયી કઠીનતા સંયોજન X ના કારણે છે. આ નમૂનાને ઉકાળતા X નું સંયોજન Y માં રૂપાંતર થાય છે. X અને Y અનુક્રમે છે :

Options :

1. $Mg(HCO_3)_2$ અને $Mg(OH)_2$
2. $Mg(HCO_3)_2$ અને $MgCO_3$
3. $Ca(HCO_3)_2$ અને $Ca(OH)_2$
4. $Ca(HCO_3)_2$ અને CaO

Question Number : 44 Question Type : MCQ Option Shuffling : Yes Display Question Number : Yes Single Line Question Option : No Option Orientation : Vertical

Correct Marks : 4 Wrong Marks : 1

The INCORRECT statement is :

Options :

1. $LiNO_3$ decomposes on heating to give $LiNO_2$ and O_2 .
2. Lithium is the strongest reducing agent among the alkali metals.
3. Lithium is least reactive with water among the alkali metals.
4. $LiCl$ crystallises from aqueous solution as $LiCl \cdot 2H_2O$.

Question Number : 44 Question Type : MCQ Option Shuffling : Yes Display Question Number : Yes Single Line Question Option : No Option Orientation : Vertical

Correct Marks : 4 Wrong Marks : 1

गलत कथन है :

Options :

1. $LiNO_3$ गरम करने पर अपघटित होकर $LiNO_2$ तथा O_2 देता है।

2. क्षार धातुओं में लीथियम प्रबलतम अपचायी कर्मक है।
3. क्षार धातुओं में लीथियम जल के साथ सबसे कम अभिक्रियाशील है।
4. LiCl जलीय विलयन से LiCl·2H₂O के रूप में क्रिस्टलित होता है।

Question Number : 44 Question Type : MCQ Option Shuffling : Yes Display Question Number : Yes Single Line Question Option : No Option Orientation : Vertical

Correct Marks : 4 Wrong Marks : 1

સાચું વિધાન નથી તે :

Options :

1. LiNO₃ ને ગરમ કરતા વિઘટન પામી LiNO₂ અને O₂ આપે છે.
2. આલ્કલીય ધાતુઓમાં લીથીયમ સૌથી પ્રબળ રિડેક્શનકર્તા છે.
3. આલ્કલીય ધાતુઓમાં લીથીયમ પાણી સાથે સૌથી ઓછો સક્રીય છે.
4. જલીય દ્રાવણમાંથી LiCl નું સ્ફટીકીકરણ LiCl·2H₂O રૂપે થાય છે.

Question Number : 45 Question Type : MCQ Option Shuffling : Yes Display Question Number : Yes Single Line Question Option : No Option Orientation : Vertical

Correct Marks : 4 Wrong Marks : 1

The C – C bond length is maximum in :

Options :

1. C₆₀
2. graphite
3. diamond
4. C₇₀

Question Number : 45 Question Type : MCQ Option Shuffling : Yes Display Question Number : Yes Single Line Question Option : No Option Orientation : Vertical

Correct Marks : 4 Wrong Marks : 1

निम्न में से किसमें C-C आबन्ध लम्बाई अधिकतम है?

Options :

1. C_{60}
2. ग्रेफाइट
3. हीरा (डायमंड)
4. C_{70}

Question Number : 45 Question Type : MCQ Option Shuffling : Yes Display Question Number : Yes Single Line Question Option : No Option Orientation : Vertical

Correct Marks : 4 Wrong Marks : 1

C-C बंध लंबाई महत्तम श्रेणी में है?

Options :

1. C_{60}
2. ग्रेफाइट
3. हीरा
4. C_{70}

Question Number : 46 Question Type : MCQ Option Shuffling : Yes Display Question Number : Yes Single Line Question Option : No Option Orientation : Vertical

Correct Marks : 4 Wrong Marks : 1

Thermal decomposition of a Mn compound (X) at 513 K results in compound Y, MnO_2 and a gaseous product. MnO_2 reacts with NaCl and concentrated H_2SO_4 to give a pungent gas Z. X, Y, and Z, respectively, are :

Options :

1. K_2MnO_4 , $KMnO_4$ and SO_2
2. $KMnO_4$, K_2MnO_4 and Cl_2

3. K_2MnO_4 , $KMnO_4$ and Cl_2

4. K_3MnO_4 , K_2MnO_4 and Cl_2

Question Number : 46 Question Type : MCQ Option Shuffling : Yes Display Question Number : Yes Single Line Question Option : No Option Orientation : Vertical

Correct Marks : 4 Wrong Marks : 1

513 K પર, એક Mn યૌગિક (X) કે તાપીય અપઘટન સે યૌગિક Y, MnO_2 તથા એક ગૈસીય ઉત્પાદ પ્રાપ્ત હોતા હૈ। $NaCl$ તથા સાન્દ્ર H_2SO_4 સે MnO_2 અભિક્રિયા કરકે એક તીઁખી ગૈસ Z દેતા હૈ। X, Y તથા Z ક્રમશઃ હૈ :

Options :

1. K_2MnO_4 , $KMnO_4$ તથા SO_2

2. $KMnO_4$, K_2MnO_4 તથા Cl_2

3. K_2MnO_4 , $KMnO_4$ તથા Cl_2

4. K_3MnO_4 , K_2MnO_4 તથા Cl_2

Question Number : 46 Question Type : MCQ Option Shuffling : Yes Display Question Number : Yes Single Line Question Option : No Option Orientation : Vertical

Correct Marks : 4 Wrong Marks : 1

513 K, Mn સંયોજન (X) નું ઉષ્મીય વિઘટન થતા સંયોજન Y, MnO_2 અને વાયુમયી પેદાશ નીપજે છે. MnO_2 એ $NaCl$ અને સાન્દ્ર H_2SO_4 સાથે પ્રક્રિયા કરી ગંધ મારતો વાયુ Z આપે છે. X, Y અને Z અનુક્રમે છે :

Options :

1. K_2MnO_4 , $KMnO_4$ અને SO_2

2. $KMnO_4$, K_2MnO_4 અને Cl_2

3. K_2MnO_4 , $KMnO_4$ અને Cl_2

4. K_3MnO_4 , K_2MnO_4 અને Cl_2

Question Number : 47 Question Type : MCQ Option Shuffling : Yes Display Question Number : Yes Single Line Question Option : No Option Orientation : Vertical

Correct Marks : 4 Wrong Marks : 1

The pair that has similar atomic radii is :

Options :

1. Ti and Hf
2. Mn and Re
3. Sc and Ni
4. Mo and W

Question Number : 47 Question Type : MCQ Option Shuffling : Yes Display Question Number : Yes Single Line Question Option : No Option Orientation : Vertical

Correct Marks : 4 Wrong Marks : 1

वह युग्म जिसकी परमाण्विक त्रिज्यायें एक जैसी हैं, होगा :

Options :

1. Ti तथा Hf
2. Mn तथा Re
3. Sc तथा Ni
4. Mo तथा W

Question Number : 47 Question Type : MCQ Option Shuffling : Yes Display Question Number : Yes Single Line Question Option : No Option Orientation : Vertical

Correct Marks : 4 Wrong Marks : 1

બેડ કે બેની સરખી પરમાણ્વીય ત્રિજ્યા છે તે :

Options :

1. Ti અને Hf
2. Mn અને Re
3. Sc અને Ni
4. Mo અને W

Question Number : 48 Question Type : MCQ Option Shuffling : Yes Display Question Number : Yes Single Line Question Option : No Option Orientation : Vertical

Correct Marks : 4 Wrong Marks : 1

The compound used in the treatment of lead poisoning is :

Options :

1. D-penicillamine
2. EDTA
3. Cis-platin
4. desferrioxime B

Question Number : 48 Question Type : MCQ Option Shuffling : Yes Display Question Number : Yes Single Line Question Option : No Option Orientation : Vertical

Correct Marks : 4 Wrong Marks : 1

लेड विषकृता के उपचार में प्रयुक्त यौगिक है :

Options :

1. D-पेनीसिलामाइन
2. EDTA
3. सिस-प्लेटिन
4. डेसफेरीआक्साइम B

Question Number : 48 Question Type : MCQ Option Shuffling : Yes Display Question Number : Yes Single Line Question Option : No Option Orientation : Vertical

Correct Marks : 4 Wrong Marks : 1

लेड विषकृता उपचार माटे वपरातुं संयोजन छे :

Options :

1. D-पेनीसिलेमाइन
2. EDTA
3. सिस-प्लेटिन
4. डेसफेरीआक्साइम B

Question Number : 49 Question Type : MCQ Option Shuffling : Yes Display Question Number : Yes Single Line Question Option : No Option Orientation : Vertical

Correct Marks : 4 Wrong Marks : 1

The coordination numbers of Co and Al in $[\text{Co}(\text{Cl})(\text{en})_2]\text{Cl}$ and $\text{K}_3[\text{Al}(\text{C}_2\text{O}_4)_3]$, respectively, are :

(en = ethane-1, 2-diamine)

Options :

1. 6 and 6
2. 3 and 3
3. 5 and 6
4. 5 and 3

Question Number : 49 Question Type : MCQ Option Shuffling : Yes Display Question Number : Yes Single Line Question Option : No Option Orientation : Vertical

Correct Marks : 4 Wrong Marks : 1

$[\text{Co}(\text{Cl})(\text{en})_2]\text{Cl}$ तथा $\text{K}_3[\text{Al}(\text{C}_2\text{O}_4)_3]$ में Co तथा Al की उपसहसंयोजन संख्यायें, क्रमशः, हैं :

(en = एथेन-1, 2-डाइऐमीन)

Options :

1. 6 तथा 6
2. 3 तथा 3
3. 5 तथा 6
4. 5 तथा 3

Question Number : 49 Question Type : MCQ Option Shuffling : Yes Display Question Number : Yes Single Line Question Option : No Option Orientation : Vertical

Correct Marks : 4 Wrong Marks : 1

$[\text{Co}(\text{Cl})(\text{en})_2]\text{Cl}$ અને $\text{K}_3[\text{Al}(\text{C}_2\text{O}_4)_3]$ માં Co અને Al નો સર્વળ આક અનુક્રમે છે :

(en = ઈથેન-1, 2-ડાઈએમાઈન)

Options :

1. 6 અને 6
2. 3 અને 3
3. 5 અને 6

4. 5 અને 3

Question Number : 50 Question Type : MCQ Option Shuffling : Yes Display Question Number : Yes Single Line Question Option : No Option Orientation : Vertical

Correct Marks : 4 Wrong Marks : 1

The primary pollutant that leads to photochemical smog is :

Options :

1. ozone
2. sulphur dioxide
3. acrolein
4. nitrogen oxides

Question Number : 50 Question Type : MCQ Option Shuffling : Yes Display Question Number : Yes Single Line Question Option : No Option Orientation : Vertical

Correct Marks : 4 Wrong Marks : 1

પ્રાથમિક પ્રદૂષક જો પ્રકાશરાસાયનિક ધૂમકુહા પૈદા કરતા હૈ, હૈ :

Options :

1. ઓઝોન
2. સલ્ફર ડાઇઑક્સાઇડ
3. ઍક્રોલીન
4. નાઇટ્રોજન ઑક્સાઇડે

Question Number : 50 Question Type : MCQ Option Shuffling : Yes Display Question Number : Yes Single Line Question Option : No Option Orientation : Vertical

Correct Marks : 4 Wrong Marks : 1

પ્રાથમિક પ્રદૂષકો કે જે પ્રકાશ રાસાયણિક ધુમ-ધુમ્મસમાં દોરી જાય છે તે :

Options :

1. ઓઝોન
2. સલ્ફર ડાઇઑક્સાઇડ

3. એકોલીન

4. નાઇટ્રોજન ઓક્સાઇડ્સ

Question Number : 51 Question Type : MCQ Option Shuffling : Yes Display Question Number : Yes Single Line Question Option : No Option Orientation : Vertical

Correct Marks : 4 Wrong Marks : 1

25 g of an unknown hydrocarbon upon burning produces 88 g of CO_2 and 9 g of H_2O . This unknown hydrocarbon contains :

Options :

1. 20 g of carbon and 5 g of hydrogen
2. 24 g of carbon and 1 g of hydrogen
3. 22 g of carbon and 3 g of hydrogen
4. 18 g of carbon and 7 g of hydrogen

Question Number : 51 Question Type : MCQ Option Shuffling : Yes Display Question Number : Yes Single Line Question Option : No Option Orientation : Vertical

Correct Marks : 4 Wrong Marks : 1

एक अज्ञात हाइड्रोकार्बन के 25 g को जलाने पर 88 g CO_2 तथा 9 g H_2O उत्पन्न होते हैं। इस अज्ञात हाइड्रोकार्बन में ये सन्निहित हैं,

Options :

1. 20 g कार्बन तथा 5 g हाइड्रोजन
2. 24 g कार्बन तथा 1 g हाइड्रोजन
3. 22 g कार्बન तथा 3 g हाइड्रोजन
4. 18 g कार्बन तथा 7 g हाइड्रोजन

Question Number : 51 Question Type : MCQ Option Shuffling : Yes Display Question Number : Yes Single Line Question Option : No Option Orientation : Vertical

Correct Marks : 4 Wrong Marks : 1

25 g અજ્ઞાત હાઇડ્રોકાર્બને સળગાવતા 88 g CO_2 અને 9 g પાણી ઉત્પન્ન થાય છે. અજ્ઞાત હાઇડ્રોકાર્બન ધરાવે છે.

Options :

1. 20 g કાર્બન અને 5 g હાઇડ્રોજન
2. 24 g કાર્બન અને 1 g હાઇડ્રોજન
3. 22 g કાર્બન અને 3 g હાઇડ્રોજન
4. 18 g કાર્બન અને 7 g હાઇડ્રોજન

Question Number : 52 Question Type : MCQ Option Shuffling : Yes Display Question Number : Yes Single Line Question Option : No Option Orientation : Vertical

Correct Marks : 4 Wrong Marks : 1

The ratio of number of atoms present in a simple cubic, body centered cubic and face centered cubic structure are, respectively :

Options :

1. 8:1:6
2. 1:2:4
3. 4:2:3
4. 4:2:1

Question Number : 52 Question Type : MCQ Option Shuffling : Yes Display Question Number : Yes Single Line Question Option : No Option Orientation : Vertical

Correct Marks : 4 Wrong Marks : 1

सरल घनीय, अंतःकेन्द्रित घनीय तथा फलक केन्द्रित घनीय संरचना में उपस्थित परमाणुओं की संख्या का अनुपात क्रमशः, होगा :

Options :

1. 8:1:6
2. 1:2:4
3. 4:2:3
4. 4:2:1

Question Number : 52 Question Type : MCQ Option Shuffling : Yes Display Question Number : Yes Single Line Question Option : No Option Orientation : Vertical

Correct Marks : 4 Wrong Marks : 1

સાદા ઘન, અંતઃ કેન્દ્રીત ઘન અને ફલક કેન્દ્રીત ઘન બંધારણમાં રહેતા પરમાણુઓની સંખ્યાનો ગુણોત્તર અનુક્રમે છે.

Options :

1. 8:1:6
2. 1:2:4
3. 4:2:3
4. 4:2:1

Question Number : 53 Question Type : MCQ Option Shuffling : Yes Display Question Number : Yes Single Line Question Option : No Option Orientation : Vertical

Correct Marks : 4 Wrong Marks : 1

Among the following, the energy of 2s orbital is lowest in :

Options :

1. H
2. K
3. Na
4. Li

Question Number : 53 Question Type : MCQ Option Shuffling : Yes Display Question Number : Yes Single Line Question Option : No Option Orientation : Vertical

Correct Marks : 4 Wrong Marks : 1

निम्न में, 2s कक्षक की ऊर्जा किसमें निम्नतम है?

Options :

1. H
2. K
3. Na
4. Li

Question Number : 53 Question Type : MCQ Option Shuffling : Yes Display Question Number : Yes Single Line Question Option : No Option Orientation : Vertical

Correct Marks : 4 Wrong Marks : 1

નીચેના પૈકી કોની 2s કક્ષકની શક્તિ સૌથી ઓછી છે ?

Options :

1. H
2. K
3. Na
4. Li

Question Number : 54 Question Type : MCQ Option Shuffling : Yes Display Question Number : Yes Single Line Question Option : No Option Orientation : Vertical

Correct Marks : 4 Wrong Marks : 1

The INCORRECT match in the following is :

Options :

1. $\Delta G^0 < 0, K > 1$
2. $\Delta G^0 < 0, K < 1$
3. $\Delta G^0 > 0, K < 1$
4. $\Delta G^0 = 0, K = 1$

Question Number : 54 Question Type : MCQ Option Shuffling : Yes Display Question Number : Yes Single Line Question Option : No Option Orientation : Vertical

Correct Marks : 4 Wrong Marks : 1

निम्न में गलत मिलान किसमें है ?

Options :

1. $\Delta G^0 < 0, K > 1$
2. $\Delta G^0 < 0, K < 1$
3. $\Delta G^0 > 0, K < 1$
4. $\Delta G^0 = 0, K = 1$

Question Number : 54 Question Type : MCQ Option Shuffling : Yes Display Question Number : Yes Single Line Question Option : No Option Orientation : Vertical

Correct Marks : 4 Wrong Marks : 1

नीचेना पैकी जोडकुं जे सायुं नथी ते :

Options :

1. $\Delta G^0 < 0, K > 1$
2. $\Delta G^0 < 0, K < 1$
3. $\Delta G^0 > 0, K < 1$
4. $\Delta G^0 = 0, K = 1$

Question Number : 55 Question Type : MCQ Option Shuffling : Yes Display Question Number : Yes Single Line Question Option : No Option Orientation : Vertical

Correct Marks : 4 Wrong Marks : 1

A solution is prepared by dissolving 0.6 g of urea (molar mass = 60 g mol^{-1}) and 1.8 g of glucose (molar mass = 180 g mol^{-1}) in 100 mL of water at 27°C . The osmotic pressure of the solution is :

($R = 0.08206 \text{ L atm K}^{-1} \text{ mol}^{-1}$)

Options :

1. 4.92 atm
2. 2.46 atm
3. 1.64 atm
4. 8.2 atm

Question Number : 55 Question Type : MCQ Option Shuffling : Yes Display Question Number : Yes Single Line Question Option : No Option Orientation : Vertical

Correct Marks : 4 Wrong Marks : 1

27°C पर, एक विलयन को 100 mL जल में 0.6 g यूरिया (मोलर द्रव्यमान = 60 g mol^{-1}) तथा 1.8 g ग्लूकोज (मोलर द्रव्यमान = 180 g mol^{-1}) घोलकर तैयार किया गया। विलयन का परासरण दाब होगा :

($R = 0.08206 \text{ L atm K}^{-1} \text{ mol}^{-1}$)

Options :

1. 4.92 atm

2. 2.46 atm
3. 1.64 atm
4. 8.2 atm

Question Number : 55 Question Type : MCQ Option Shuffling : Yes Display Question Number : Yes Single Line Question Option : No Option Orientation : Vertical

Correct Marks : 4 Wrong Marks : 1

27°C એ 0.6 g યુરિયા (મોલર દળ = 60 g mol⁻¹) અને 1.8 g સુક્રોઝનું (મોલર દળ = 180 g mol⁻¹) 100 mL પાણીમાં ઓગાળીને દ્રાવણ બનવવામાં આવ્યું. દ્રાવણનું (પરાસરણ) અભિસારણ દબાણ છે : (R = 0.08206 L atm K⁻¹ mol⁻¹)

Options :

1. 4.92 atm
2. 2.46 atm
3. 1.64 atm
4. 8.2 atm

Question Number : 56 Question Type : MCQ Option Shuffling : Yes Display Question Number : Yes Single Line Question Option : No Option Orientation : Vertical

Correct Marks : 4 Wrong Marks : 1

In which one of the following equilibria,

$$K_p \neq K_c ?$$

Options :

1. $\text{NO}_2(\text{g}) + \text{SO}_2(\text{g}) = \text{NO}(\text{g}) + \text{SO}_3(\text{g})$
2. $2 \text{HI}(\text{g}) = \text{H}_2(\text{g}) + \text{I}_2(\text{g})$
3. $2 \text{C}(\text{s}) + \text{O}_2(\text{g}) = 2 \text{CO}(\text{g})$
4. $2 \text{NO}(\text{g}) = \text{N}_2(\text{g}) + \text{O}_2(\text{g})$

Question Number : 56 Question Type : MCQ Option Shuffling : Yes Display Question Number : Yes Single Line Question Option : No Option Orientation : Vertical

Correct Marks : 4 Wrong Marks : 1

निम्न किस एक साम्य में $K_p \neq K_c$ है?

Options :

1. $\text{NO}_2(\text{g}) + \text{SO}_2(\text{g}) = \text{NO}(\text{g}) + \text{SO}_3(\text{g})$
2. $2\text{HI}(\text{g}) = \text{H}_2(\text{g}) + \text{I}_2(\text{g})$
3. $2\text{C}(\text{s}) + \text{O}_2(\text{g}) = 2\text{CO}(\text{g})$
4. $2\text{NO}(\text{g}) = \text{N}_2(\text{g}) + \text{O}_2(\text{g})$

Question Number : 56 Question Type : MCQ Option Shuffling : Yes Display Question Number : Yes Single Line Question Option : No Option Orientation : Vertical

Correct Marks : 4 Wrong Marks : 1

नीचेना पैकी कया अके संतुलनने $K_p \neq K_c$ थरी?

Options :

1. $\text{NO}_2(\text{g}) + \text{SO}_2(\text{g}) = \text{NO}(\text{g}) + \text{SO}_3(\text{g})$
2. $2\text{HI}(\text{g}) = \text{H}_2(\text{g}) + \text{I}_2(\text{g})$
3. $2\text{C}(\text{s}) + \text{O}_2(\text{g}) = 2\text{CO}(\text{g})$
4. $2\text{NO}(\text{g}) = \text{N}_2(\text{g}) + \text{O}_2(\text{g})$

Question Number : 57 Question Type : MCQ Option Shuffling : Yes Display Question Number : Yes Single Line Question Option : No Option Orientation : Vertical

Correct Marks : 4 Wrong Marks : 1

The molar solubility of $\text{Cd}(\text{OH})_2$ is 1.84×10^{-5} M in water. The expected solubility of $\text{Cd}(\text{OH})_2$ in a buffer solution of $\text{pH} = 12$ is :

Options :

1. 6.23×10^{-11} M
2. 2.49×10^{-10} M
3. $\frac{2.49}{1.84} \times 10^{-9}$ M

4. $1.84 \times 10^{-9} \text{ M}$

Question Number : 57 Question Type : MCQ Option Shuffling : Yes Display Question Number : Yes Single Line Question Option : No Option Orientation : Vertical

Correct Marks : 4 Wrong Marks : 1

जल में $\text{Cd}(\text{OH})_2$ की मोलर विलेयता $1.84 \times 10^{-5} \text{ M}$ है। $\text{pH} = 12$ के एक बफर विलयन में $\text{Cd}(\text{OH})_2$ की सम्भावित विलेयता होगी :

Options :

1. $6.23 \times 10^{-11} \text{ M}$

2. $2.49 \times 10^{-10} \text{ M}$

3. $\frac{2.49}{1.84} \times 10^{-9} \text{ M}$

4. $1.84 \times 10^{-9} \text{ M}$

Question Number : 57 Question Type : MCQ Option Shuffling : Yes Display Question Number : Yes Single Line Question Option : No Option Orientation : Vertical

Correct Marks : 4 Wrong Marks : 1

$\text{Cd}(\text{OH})_2$ ની પાણીમાં મોલર દ્રાવ્યતા $1.84 \times 10^{-5} \text{ M}$ છે. $\text{pH} = 12$ બફર દ્રાવણમાં $\text{Cd}(\text{OH})_2$ ને આપેક્ષિત દ્રાવ્યતા છે :

Options :

1. $6.23 \times 10^{-11} \text{ M}$

2. $2.49 \times 10^{-10} \text{ M}$

3. $\frac{2.49}{1.84} \times 10^{-9} \text{ M}$

4. $1.84 \times 10^{-9} \text{ M}$

Question Number : 58 Question Type : MCQ Option Shuffling : Yes Display Question Number : Yes Single Line Question Option : No Option Orientation : Vertical

Correct Marks : 4 Wrong Marks : 1

The decreasing order of electrical conductivity of the following aqueous solutions is :

0.1 M Formic acid (A),

0.1 M Acetic acid (B),

0.1 M Benzoic acid (C).

Options :

1. $A > B > C$

2. $C > A > B$

3. $C > B > A$

4. $A > C > B$

Question Number : 58 Question Type : MCQ Option Shuffling : Yes Display Question Number : Yes Single Line Question Option : No Option Orientation : Vertical

Correct Marks : 4 Wrong Marks : 1

निम्न जलीय विलयनों की विद्युतीय चालकता का घटता क्रम है,

0.1 M फार्मिक एसिड (A),

0.1 M एसिटिक एसिड (B),

0.1 M बेन्जोइक एसिड (C).

Options :

1. $A > B > C$

2. $C > A > B$

3. $C > B > A$

4. $A > C > B$

Question Number : 58 Question Type : MCQ Option Shuffling : Yes Display Question Number : Yes Single Line Question Option : No Option Orientation : Vertical

Correct Marks : 4 Wrong Marks : 1

નીચેના જલીય દ્રાવણની વિદ્યુત વાહકતાનો ઘટતો ક્રમ છે :

0.1 M ફાર્મિક એસિડ (A),

0.1 M એસિટિક એસિડ (B),

0.1 M બેન્ઝોઇક એસિડ (C)

Options :

1. $A > B > C$

2. $C > A > B$

3. $C > B > A$

4. $A > C > B$

Question Number : 59 Question Type : MCQ Option Shuffling : Yes Display Question Number : Yes Single Line Question Option : No Option Orientation : Vertical

Correct Marks : 4 Wrong Marks : 1

NO_2 required for a reaction is produced by the decomposition of N_2O_5 in CCl_4 as per the equation,



The initial concentration of N_2O_5 is 3.00 mol L^{-1} and it is 2.75 mol L^{-1} after 30 minutes. The rate of formation of NO_2 is :

Options :

1. $4.167 \times 10^{-3} \text{ mol L}^{-1} \text{ min}^{-1}$

2. $8.333 \times 10^{-3} \text{ mol L}^{-1} \text{ min}^{-1}$

3. $2.083 \times 10^{-3} \text{ mol L}^{-1} \text{ min}^{-1}$

4. $1.667 \times 10^{-2} \text{ mol L}^{-1} \text{ min}^{-1}$

Question Number : 59 Question Type : MCQ Option Shuffling : Yes Display Question Number : Yes Single Line Question Option : No Option Orientation : Vertical

Correct Marks : 4 Wrong Marks : 1

एक अभिक्रिया के लिए आवश्यक NO_2 को CCl_4 में N_2O_5 के अपघटन द्वारा उत्पन्न करते हैं, जैसा कि नीचे समीकरण में है,



N_2O_5 की प्रारम्भिक सांद्रता 3.00 mol L^{-1} तथा 30 मिनट के बाद की सांद्रता 2.75 mol L^{-1} है। NO_2 के सम्भवन की दर होगी :

Options :

1. $4.167 \times 10^{-3} \text{ mol L}^{-1} \text{ min}^{-1}$
2. $8.333 \times 10^{-3} \text{ mol L}^{-1} \text{ min}^{-1}$
3. $2.083 \times 10^{-3} \text{ mol L}^{-1} \text{ min}^{-1}$
4. $1.667 \times 10^{-2} \text{ mol L}^{-1} \text{ min}^{-1}$

Question Number : 59 Question Type : MCQ Option Shuffling : Yes Display Question Number : Yes Single Line Question Option : No Option Orientation : Vertical

Correct Marks : 4 Wrong Marks : 1

N_2O_5 નું CCl_4 માં આપેલ સમીકરણ મુજબ વિઘટન કરી એક પ્રક્રિયામાટે જરૂરી NO_2 નું ઉત્પાદન થાય છે.



N_2O_5 ની શરૂઆતની સાંદ્રતા 3.00 mol L^{-1} અને 30 મિનિટ પછી 2.75 mol L^{-1} છે. તો NO_2 ની બનાવટનો દર શોધો :

Options :

1. $4.167 \times 10^{-3} \text{ mol L}^{-1} \text{ min}^{-1}$
2. $8.333 \times 10^{-3} \text{ mol L}^{-1} \text{ min}^{-1}$
3. $2.083 \times 10^{-3} \text{ mol L}^{-1} \text{ min}^{-1}$
4. $1.667 \times 10^{-2} \text{ mol L}^{-1} \text{ min}^{-1}$

Question Number : 60 Question Type : MCQ Option Shuffling : Yes Display Question Number : Yes Single Line Question Option : No Option Orientation : Vertical

Correct Marks : 4 Wrong Marks : 1

Among the following, the INCORRECT statement about colloids is :

Options :

1. The range of diameters of colloidal particles is between 1 and 1000 nm.
2. They can scatter light.

3. The osmotic pressure of a colloidal solution is of higher order than the true solution at the same concentration.

4. They are larger than small molecules and have high molar mass.

Question Number : 60 Question Type : MCQ Option Shuffling : Yes Display Question Number : Yes Single Line Question Option : No Option Orientation : Vertical

Correct Marks : 4 Wrong Marks : 1

कोलाइड्स के सम्बन्ध में निम्न कथनों में से कौन सा गलत है ?

Options :

1. कोलाइडी कणों के व्यास का परास 1 तथा 1000 nm के बीच होता है।
2. ये प्रकाश को प्रकीर्ण कर सकते हैं।
3. एक ही सांद्रता पर, कोलाइडी विलयन का परासरण दाब, वास्तविक विलयन के दाब की तुलना में उच्चतर मान का होता है।
4. ये छोटे अणुओं की तुलना में बड़े होते हैं और उनका मोलर द्रव्यमान उच्च होता है।

Question Number : 60 Question Type : MCQ Option Shuffling : Yes Display Question Number : Yes Single Line Question Option : No Option Orientation : Vertical

Correct Marks : 4 Wrong Marks : 1

नीचेना पैकी क्युं विधान कलिलो भाटे सायुं नथी?

Options :

1. कलिल कणोना व्यासनो विस्तार 1 अने 1000 nm नी वच्ये होय छे.
2. तेओ प्रकाशनुं प्रकीर्णन करी शके छे.

3. સરખી સાંદ્રતાએ કલીલ દ્રાવણનું અભિસરણ દબાણ સાથા દ્રાવણ કરતા ઉંચા કમનું છે.

4. તેઓ નાના આણુઓ કરતા મોટા છે અને ઉંચું મોલર દળ ધરાવે છે.

Mathematics

Section Id :	416529279
Section Number :	3
Section type :	Online
Mandatory or Optional:	Mandatory
Number of Questions:	30
Number of Questions to be attempted:	30
Section Marks:	120
Display Number Panel:	Yes
Group All Questions:	No

Sub-Section Number:	1
Sub-Section Id:	416529419
Question Shuffling Allowed :	Yes

Question Number : 61 Question Type : MCQ Option Shuffling : Yes Display Question Number : Yes Single Line Question Option : No Option Orientation : Vertical

Correct Marks : 4 Wrong Marks : 1

Let A, B and C be sets such that $\phi \neq A \cap B \subseteq C$. Then which of the following statements is not true ?

Options :

1. $B \cap C \neq \phi$
2. $(C \cup A) \cap (C \cup B) = C$
3. If $(A - B) \subseteq C$, then $A \subseteq C$
4. If $(A - C) \subseteq B$, then $A \subseteq B$

Question Number : 61 Question Type : MCQ Option Shuffling : Yes Display Question Number : Yes Single Line Question Option : No Option Orientation : Vertical

Correct Marks : 4 Wrong Marks : 1

माना समुच्चय A, B तथा C इस प्रकार हैं कि $\phi \neq A \cap B \subseteq C$, तो निम्न में से कौन सा कथन सत्य नहीं है?

Options :

1. $B \cap C \neq \phi$
2. $(C \cup A) \cap (C \cup B) = C$
3. यदि $(A - B) \subseteq C$, तो $A \subseteq C$
4. यदि $(A - C) \subseteq B$, तो $A \subseteq B$

Question Number : 61 Question Type : MCQ Option Shuffling : Yes Display Question Number : Yes Single Line Question Option : No Option Orientation : Vertical

Correct Marks : 4 Wrong Marks : 1

ધારો કે ગણ A, B અને C માટે $\phi \neq A \cap B \subseteq C$ તો નીચેના પૈકી કયું વિધાન સાચું નથી?

Options :

1. $B \cap C \neq \phi$
2. $(C \cup A) \cap (C \cup B) = C$
3. જો $(A - B) \subseteq C$, તો $A \subseteq C$
4. જો $(A - C) \subseteq B$, તો $A \subseteq B$

Question Number : 62 Question Type : MCQ Option Shuffling : Yes Display Question Number : Yes Single Line Question Option : No Option Orientation : Vertical

Correct Marks : 4 Wrong Marks : 1

Let $z \in \mathbb{C}$ with $\text{Im}(z) = 10$ and it satisfies

$$\frac{2z - n}{2z + n} = 2i - 1 \text{ for some natural number}$$

n. Then :

Options :

1. $n = 20$ and $\text{Re}(z) = 10$
2. $n = 20$ and $\text{Re}(z) = -10$
3. $n = 40$ and $\text{Re}(z) = 10$
4. $n = 40$ and $\text{Re}(z) = -10$

Question Number : 62 Question Type : MCQ Option Shuffling : Yes Display Question Number : Yes Single Line Question Option : No Option Orientation : Vertical

Correct Marks : 4 Wrong Marks : 1

माना $z \in \mathbb{C}$ जिसके लिए $\text{Im}(z) = 10$ तथा किसी प्राकृत

संख्या n के लिए यह $\frac{2z - n}{2z + n} = 2i - 1$ को संतुष्ट

करता है, तो :

Options :

1. $n = 20$ तथा $\text{Re}(z) = 10$
2. $n = 20$ तथा $\text{Re}(z) = -10$
3. $n = 40$ तथा $\text{Re}(z) = 10$
4. $n = 40$ तथा $\text{Re}(z) = -10$

Question Number : 62 Question Type : MCQ Option Shuffling : Yes Display Question Number : Yes Single Line Question Option : No Option Orientation : Vertical

Correct Marks : 4 Wrong Marks : 1

ધારો કે $z \in \mathbb{C}$ માટે $\text{Im}(z) = 10$ છે અને કોઈક પ્રાકૃતિક

સંખ્યા n માટે તે $\frac{2z - n}{2z + n} = 2i - 1$ નું સમાધાન કરે

છે. તો :

Options :

1. $n = 20$ અને $\text{Re}(z) = 10$
2. $n = 20$ અને $\text{Re}(z) = -10$
3. $n = 40$ અને $\text{Re}(z) = 10$
4. $n = 40$ અને $\text{Re}(z) = -10$

Question Number : 63 Question Type : MCQ Option Shuffling : Yes Display Question Number : Yes Single Line Question Option : No Option Orientation : Vertical

Correct Marks : 4 Wrong Marks : 1

If α , β and γ are three consecutive terms of a non-constant G.P. such that the equations $\alpha x^2 + 2\beta x + \gamma = 0$ and $x^2 + x - 1 = 0$ have a common root, then $\alpha(\beta + \gamma)$ is equal to :

Options :

1. $\beta\gamma$

2. $\alpha\beta$

3. $\alpha\gamma$

4. 0

Question Number : 63 Question Type : MCQ Option Shuffling : Yes Display Question Number : Yes Single Line Question Option : No Option Orientation : Vertical

Correct Marks : 4 Wrong Marks : 1

यदि एक भिन्न पदों वाली गुणोत्तर श्रेणी के तीन क्रमागत पद α , β तथा γ इस प्रकार हैं कि समीकरणों $\alpha x^2 + 2\beta x + \gamma = 0$ तथा $x^2 + x - 1 = 0$ का एक मूल समान है, तो $\alpha(\beta + \gamma)$ बराबर है :

Options :

1. $\beta\gamma$

2. $\alpha\beta$

3. $\alpha\gamma$

4. 0

Question Number : 63 Question Type : MCQ Option Shuffling : Yes Display Question Number : Yes Single Line Question Option : No Option Orientation : Vertical

Correct Marks : 4 Wrong Marks : 1

જો α , β અને γ એ અચળ ન હોય તેવી સમગુણોત્તર શ્રેણી (G.P.) ના એવા ત્રણ ક્રમિક પદો હોય કે જેથી $\alpha x^2 + 2\beta x + \gamma = 0$ અને $x^2 + x - 1 = 0$ ને સામાન્ય બીજ હોય તો $\alpha(\beta + \gamma)$ બરાબર _____ છે.

Options :

1. $\beta\gamma$

2. $\alpha\beta$

3. $\alpha\gamma$

4. 0

Question Number : 64 Question Type : MCQ Option Shuffling : Yes Display Question Number : Yes Single Line Question Option : No Option Orientation : Vertical

Correct Marks : 4 Wrong Marks : 1

A value of $\theta \in (0, \pi/3)$, for which

$$\begin{vmatrix} 1 + \cos^2\theta & \sin^2\theta & 4 \cos 6\theta \\ \cos^2\theta & 1 + \sin^2\theta & 4 \cos 6\theta \\ \cos^2\theta & \sin^2\theta & 1 + 4 \cos 6\theta \end{vmatrix} = 0, \text{ is :}$$

Options :

1. $\frac{\pi}{18}$

2. $\frac{\pi}{9}$

3. $\frac{7\pi}{24}$

4. $\frac{7\pi}{36}$

Question Number : 64 Question Type : MCQ Option Shuffling : Yes Display Question Number : Yes Single Line Question Option : No Option Orientation : Vertical

Correct Marks : 4 Wrong Marks : 1

$\theta \in (0, \pi/3)$ का एक मान, जिसके लिए

$$\begin{vmatrix} 1 + \cos^2\theta & \sin^2\theta & 4 \cos 6\theta \\ \cos^2\theta & 1 + \sin^2\theta & 4 \cos 6\theta \\ \cos^2\theta & \sin^2\theta & 1 + 4 \cos 6\theta \end{vmatrix} = 0 \text{ है, है:}$$

Options :

1. $\frac{\pi}{18}$

2. $\frac{\pi}{9}$

3. $\frac{7\pi}{24}$

4. $\frac{7\pi}{36}$

Question Number : 64 Question Type : MCQ Option Shuffling : Yes Display Question Number : Yes Single Line Question Option : No Option Orientation : Vertical

Correct Marks : 4 Wrong Marks : 1

$$\begin{vmatrix} 1 + \cos^2 \theta & \sin^2 \theta & 4 \cos 6\theta \\ \cos^2 \theta & 1 + \sin^2 \theta & 4 \cos 6\theta \\ \cos^2 \theta & \sin^2 \theta & 1 + 4 \cos 6\theta \end{vmatrix} = 0 \text{ થાય}$$

તે માટે $\theta \in (0, \pi/3)$ ની એક કિંમત _____ છે.

Options :

1. $\frac{\pi}{18}$

2. $\frac{\pi}{9}$

3. $\frac{7\pi}{24}$

4. $\frac{7\pi}{36}$

Question Number : 65 Question Type : MCQ Option Shuffling : Yes Display Question Number : Yes Single Line Question Option : No Option Orientation : Vertical

Correct Marks : 4 Wrong Marks : 1

If $[x]$ denotes the greatest integer $\leq x$, then the system of linear equations $[\sin\theta]x + [-\cos\theta]y = 0$ $[\cot\theta]x + y = 0$

Options :

has a unique solution if

1. $\theta \in \left(\frac{\pi}{2}, \frac{2\pi}{3}\right) \cup \left(\pi, \frac{7\pi}{6}\right)$.

have infinitely many solutions if

2. $\theta \in \left(\frac{\pi}{2}, \frac{2\pi}{3}\right) \cup \left(\pi, \frac{7\pi}{6}\right)$.

has a unique solution if $\theta \in \left(\frac{\pi}{2}, \frac{2\pi}{3}\right)$

and have infinitely many solutions if

$$\theta \in \left(\pi, \frac{7\pi}{6}\right).$$

3.

have infinitely many solutions if

$$\theta \in \left(\frac{\pi}{2}, \frac{2\pi}{3}\right) \text{ and has a unique}$$

$$\text{solution if } \theta \in \left(\pi, \frac{7\pi}{6}\right).$$

4.

Question Number : 65 Question Type : MCQ Option Shuffling : Yes Display Question Number : Yes Single Line Question Option : No Option Orientation : Vertical

Correct Marks : 4 Wrong Marks : 1

यदि $[x]$ महत्तम पूर्णांक $\leq x$ है, तो रेखिक समीकरण
निकाय

$$[\sin\theta]x + [-\cos\theta]y = 0$$

$$[\cot\theta]x + y = 0$$

Options :

का मात्र एक हल है यदि

$$\theta \in \left(\frac{\pi}{2}, \frac{2\pi}{3}\right) \cup \left(\pi, \frac{7\pi}{6}\right).$$

1.

के अनन्त हल हैं यदि

$$\theta \in \left(\frac{\pi}{2}, \frac{2\pi}{3}\right) \cup \left(\pi, \frac{7\pi}{6}\right).$$

2.

का मात्र एक हल है यदि $\theta \in \left(\frac{\pi}{2}, \frac{2\pi}{3}\right)$ तथा

$$\text{अनन्त हल हैं यदि } \theta \in \left(\pi, \frac{7\pi}{6}\right).$$

3.

के अनन्त हल हैं यदि $\theta \in \left(\frac{\pi}{2}, \frac{2\pi}{3}\right)$ तथा मात्र

$$\text{एक हल है यदि } \theta \in \left(\pi, \frac{7\pi}{6}\right).$$

4.

Question Number : 65 Question Type : MCQ Option Shuffling : Yes Display Question Number : Yes Single Line Question Option : No Option Orientation : Vertical

Correct Marks : 4 Wrong Marks : 1

જો $[x]$ એ x થી નાના અથવા x ને સમાન તમામ પૂર્ણાંકોમાં સૌથી મોટો પૂર્ણાંક દર્શાવે, તો સુરેખ સમીકરણ સંહિત

$$[\sin\theta]x + [-\cos\theta]y = 0$$

$$[\cot\theta]x + y = 0 \quad \text{ને :$$

Options :

અનન્ય ઉકેલ છે જો

$$\theta \in \left(\frac{\pi}{2}, \frac{2\pi}{3}\right) \cup \left(\pi, \frac{7\pi}{6}\right).$$

1.

અનંત ઉકેલો છે જો

$$\theta \in \left(\frac{\pi}{2}, \frac{2\pi}{3}\right) \cup \left(\pi, \frac{7\pi}{6}\right).$$

2.

અનન્ય ઉકેલ છે જો $\theta \in \left(\frac{\pi}{2}, \frac{2\pi}{3}\right)$ અને અનંત

$$\text{ઉકેલો છે જો } \theta \in \left(\pi, \frac{7\pi}{6}\right).$$

3.

અનંત ઉકેલો છે જો $\theta \in \left(\frac{\pi}{2}, \frac{2\pi}{3}\right)$ અને અનન્ય

$$\text{ઉકેલ છે જો } \theta \in \left(\pi, \frac{7\pi}{6}\right).$$

4.

Question Number : 66 Question Type : MCQ Option Shuffling : Yes Display Question Number : Yes Single Line Question Option : No Option Orientation : Vertical

Correct Marks : 4 Wrong Marks : 1

A group of students comprises of 5 boys and n girls. If the number of ways, in which a team of 3 students can randomly be selected from this group such that there is at least one boy and at least one girl in each team, is 1750, then n is equal to :

Options :

24

1.

2. 25
3. 27
4. 28

Question Number : 66 Question Type : MCQ Option Shuffling : Yes Display Question Number : Yes Single Line Question Option : No Option Orientation : Vertical

Correct Marks : 4 Wrong Marks : 1

विद्यार्थियों के एक समूह में 5 लड़के तथा n लड़कियाँ हैं। यदि इस समूह में से तीन विद्यार्थियों की टीम यादृच्छिक इस प्रकार चुनने के तरीके, कि प्रत्येक टीम में कम से कम एक लड़का तथा कम से कम एक लड़की हो, 1750 हैं, तो n बराबर है :

Options :

1. 24
2. 25
3. 27
4. 28

Question Number : 66 Question Type : MCQ Option Shuffling : Yes Display Question Number : Yes Single Line Question Option : No Option Orientation : Vertical

Correct Marks : 4 Wrong Marks : 1

विद्यार्थियोंનો એક સમૂહ 5 છોકરાઓ અને n છોકરીઓ દ્વારા રચાયેલ છે. જો આ સમૂહમાંથી, ઓછામાં ઓછો એક છોકરો હોય અને ઓછામાં ઓછી એક છોકરી હોય તેવી ત્રણ વિધાર્થીઓની એક ટુકડી, યાદચ્છિક રીતે પસંદ કરવાની રીતોની સંખ્યા 1750 હોય તો n બરાબર _____ છે.

Options :

1. 24
2. 25
3. 27
4. 28

Question Number : 67 Question Type : MCQ Option Shuffling : Yes Display Question Number : Yes Single Line Question Option : No Option Orientation : Vertical

Correct Marks : 4 Wrong Marks : 1

The term independent of x in the expansion

of $\left(\frac{1}{60} - \frac{x^8}{81}\right) \cdot \left(2x^2 - \frac{3}{x^2}\right)^6$ is equal to :

Options :

1. -108
2. -72
3. -36
4. 36

Question Number : 67 Question Type : MCQ Option Shuffling : Yes Display Question Number : Yes Single Line Question Option : No Option Orientation : Vertical

Correct Marks : 4 Wrong Marks : 1

$\left(\frac{1}{60} - \frac{x^8}{81}\right) \cdot \left(2x^2 - \frac{3}{x^2}\right)^6$ के प्रसार में x से

स्वतंत्र पद है :

Options :

1. -108
2. -72
3. -36
4. 36

Question Number : 67 Question Type : MCQ Option Shuffling : Yes Display Question Number : Yes Single Line Question Option : No Option Orientation : Vertical

Correct Marks : 4 Wrong Marks : 1

$\left(\frac{1}{60} - \frac{x^8}{81}\right) \cdot \left(2x^2 - \frac{3}{x^2}\right)^6$ ना विस्तारणामां x

थी स्वतंत्र पद _____ छे.

Options :

1. -108

2. -72

3. -36

4. 36

Question Number : 68 Question Type : MCQ Option Shuffling : Yes Display Question Number : Yes Single Line Question Option : No Option Orientation : Vertical

Correct Marks : 4 Wrong Marks : 1

If a_1, a_2, a_3, \dots are in A.P. such that $a_1 + a_7 + a_{16} = 40$, then the sum of the first 15 terms of this A.P. is :

Options :

1. 150

2. 120

3. 280

4. 200

Question Number : 68 Question Type : MCQ Option Shuffling : Yes Display Question Number : Yes Single Line Question Option : No Option Orientation : Vertical

Correct Marks : 4 Wrong Marks : 1

यदि a_1, a_2, a_3, \dots एक समान्तर श्रेणी में इस प्रकार हैं कि $a_1 + a_7 + a_{16} = 40$ है, तो इस समान्तर श्रेणी के प्रथम 15 पदों का योगफल है :

Options :

1. 150

2. 120

3. 280

4. 200

Question Number : 68 Question Type : MCQ Option Shuffling : Yes Display Question Number : Yes Single Line Question Option : No Option Orientation : Vertical

Correct Marks : 4 Wrong Marks : 1

જો a_1, a_2, a_3, \dots એવી સમાન્તર શ્રેણી (A.P.) હોય જેથી $a_1 + a_7 + a_{16} = 40$ તો આ A.P. ના પ્રથમ 15 પદોનો સરવાળો _____ છે.

Options :

1. 150
2. 120
3. 280
4. 200

Question Number : 69 Question Type : MCQ Option Shuffling : Yes Display Question Number : Yes Single Line Question Option : No Option Orientation : Vertical

Correct Marks : 4 Wrong Marks : 1

If ${}^{20}C_1 + (2^2) {}^{20}C_2 + (3^2) {}^{20}C_3 + \dots + (20^2) {}^{20}C_{20} = A(2^\beta)$, then the ordered pair (A, β) is equal to :

Options :

1. (380, 18)
2. (380, 19)
3. (420, 18)
4. (420, 19)

Question Number : 69 Question Type : MCQ Option Shuffling : Yes Display Question Number : Yes Single Line Question Option : No Option Orientation : Vertical

Correct Marks : 4 Wrong Marks : 1

यदि ${}^{20}C_1 + (2^2) {}^{20}C_2 + (3^2) {}^{20}C_3 + \dots + (20^2) {}^{20}C_{20} = A(2^\beta)$, तो क्रमित युग्म (A, β) बराबर है :

Options :

1. (380, 18)
2. (380, 19)
3. (420, 18)

4. (420, 19)

Question Number : 69 Question Type : MCQ Option Shuffling : Yes Display Question Number : Yes Single Line Question Option : No Option Orientation : Vertical

Correct Marks : 4 Wrong Marks : 1

જો ${}^{20}C_1 + (2^2) {}^{20}C_2 + (3^2) {}^{20}C_3 + \dots + (20^2) {}^{20}C_{20} = A(2^\beta)$ તો કમચુકત જોડ (A, β) બરાબર _____ છે.

Options :

1. (380, 18)

2. (380, 19)

3. (420, 18)

4. (420, 19)

Question Number : 70 Question Type : MCQ Option Shuffling : Yes Display Question Number : Yes Single Line Question Option : No Option Orientation : Vertical

Correct Marks : 4 Wrong Marks : 1

$\lim_{x \rightarrow 0} \frac{x + 2\sin x}{\sqrt{x^2 + 2\sin x + 1} - \sqrt{\sin^2 x - x + 1}}$

is :

Options :

1. 1

2. 2

3. 3

4. 6

Question Number : 70 Question Type : MCQ Option Shuffling : Yes Display Question Number : Yes Single Line Question Option : No Option Orientation : Vertical

Correct Marks : 4 Wrong Marks : 1

$\lim_{x \rightarrow 0} \frac{x + 2\sin x}{\sqrt{x^2 + 2\sin x + 1} - \sqrt{\sin^2 x - x + 1}}$

બરાબર છે :

Options :

1. 1

2. 2

3. 3

4. 6

Question Number : 70 Question Type : MCQ Option Shuffling : Yes Display Question Number : Yes Single Line Question Option : No Option Orientation : Vertical

Correct Marks : 4 Wrong Marks : 1

$$\lim_{x \rightarrow 0} \frac{x + 2 \sin x}{\sqrt{x^2 + 2 \sin x + 1} - \sqrt{\sin^2 x - x + 1}}$$

ଉତ୍ତର _____ ଓ.

Options :

1. 1

2. 2

3. 3

4. 6

Question Number : 71 Question Type : MCQ Option Shuffling : Yes Display Question Number : Yes Single Line Question Option : No Option Orientation : Vertical

Correct Marks : 4 Wrong Marks : 1

The derivative of $\tan^{-1}\left(\frac{\sin x - \cos x}{\sin x + \cos x}\right)$,

with respect to $\frac{x}{2}$, where $\left(x \in \left(0, \frac{\pi}{2}\right)\right)$ is:

Options :

1. 1

2. $\frac{1}{2}$

3. 2

4. $\frac{2}{3}$

Question Number : 71 Question Type : MCQ Option Shuffling : Yes Display Question Number : Yes Single Line Question Option : No Option Orientation : Vertical

Correct Marks : 4 Wrong Marks : 1

$\frac{x}{2}$ के सापेक्ष $\tan^{-1}\left(\frac{\sin x - \cos x}{\sin x + \cos x}\right)$, जहाँ

$\left(x \in \left(0, \frac{\pi}{2}\right)\right)$ का अवकलज है :

Options :

1. 1

2. $\frac{1}{2}$

3. 2

4. $\frac{2}{3}$

Question Number : 71 Question Type : MCQ Option Shuffling : Yes Display Question Number : Yes Single Line Question Option : No Option Orientation : Vertical

Correct Marks : 4 Wrong Marks : 1

$\tan^{-1}\left(\frac{\sin x - \cos x}{\sin x + \cos x}\right)$, $\frac{x}{2}$ की सापेक्ष विकलन

_____ है, अर्थात् $\left(x \in \left(0, \frac{\pi}{2}\right)\right)$.

Options :

1. 1

2. $\frac{1}{2}$

3. 2

4. $\frac{2}{3}$

Question Number : 72 Question Type : MCQ Option Shuffling : Yes Display Question Number : Yes Single Line Question Option : No Option Orientation : Vertical

Correct Marks : 4 Wrong Marks : 1

The tangents to the curve $y = (x - 2)^2 - 1$ at its points of intersection with the line $x - y = 3$, intersect at the point :

Options :

1. $\left(\frac{5}{2}, -1\right)$

2. $\left(-\frac{5}{2}, -1\right)$

3. $\left(\frac{5}{2}, 1\right)$

4. $\left(-\frac{5}{2}, 1\right)$

Question Number : 72 Question Type : MCQ Option Shuffling : Yes Display Question Number : Yes Single Line Question Option : No Option Orientation : Vertical

Correct Marks : 4 Wrong Marks : 1

વક્ર $y = (x-2)^2 - 1$ કે રેખા $x - y = 3$ સે પ્રતિચ્છેદન બિન્દુઓ પર વક્ર કી સ્પર્શરેખાએ નિમ્ન મેં સે કિસ બિન્દુ પર મિલતી હૈં?

Options :

1. $\left(\frac{5}{2}, -1\right)$

2. $\left(-\frac{5}{2}, -1\right)$

3. $\left(\frac{5}{2}, 1\right)$

4. $\left(-\frac{5}{2}, 1\right)$

Question Number : 72 Question Type : MCQ Option Shuffling : Yes Display Question Number : Yes Single Line Question Option : No Option Orientation : Vertical

Correct Marks : 4 Wrong Marks : 1

વક્ર $y = (x-2)^2 - 1$ ના રેખા $x - y = 3$ સાથેના છેદબિંદુઓ આગળના સ્પર્શકો, _____ બિંદુમાં છેદે છે.

Options :

1. $\left(\frac{5}{2}, -1\right)$

2. $\left(-\frac{5}{2}, -1\right)$

3. $\left(\frac{5}{2}, 1\right)$

4. $\left(-\frac{5}{2}, 1\right)$

Question Number : 73 Question Type : MCQ Option Shuffling : Yes Display Question Number : Yes Single Line Question Option : No Option Orientation : Vertical

Correct Marks : 4 Wrong Marks : 1

Let $f(x) = 5 - |x - 2|$ and $g(x) = |x + 1|$,
 $x \in \mathbb{R}$. If $f(x)$ attains maximum value at α
and $g(x)$ attains minimum value at β , then

$\lim_{x \rightarrow -\alpha\beta} \frac{(x-1)(x^2 - 5x + 6)}{x^2 - 6x + 8}$ is equal to :

Options :

1. $1/2$

2. $-1/2$

3. $3/2$

4. $-3/2$

Question Number : 73 Question Type : MCQ Option Shuffling : Yes Display Question Number : Yes Single Line Question Option : No Option Orientation : Vertical

Correct Marks : 4 Wrong Marks : 1

माना $f(x) = 5 - |x - 2|$ तथा $g(x) = |x + 1|$,
 $x \in \mathbb{R}$. यदि $f(x)$ का अधिकतम मान α पर है तथा $g(x)$
का न्यूनतम मान β पर है, तो

$\lim_{x \rightarrow -\alpha\beta} \frac{(x-1)(x^2 - 5x + 6)}{x^2 - 6x + 8}$ बराबर है :

Options :

1. $1/2$

2. $-1/2$

3. $3/2$

4. $-3/2$

Question Number : 73 Question Type : MCQ Option Shuffling : Yes Display Question Number : Yes Single Line Question Option : No Option Orientation : Vertical

Correct Marks : 4 Wrong Marks : 1

ધારો કે $f(x) = 5 - |x - 2|$ અને $g(x) = |x + 1|$,
 $x \in \mathbb{R}$ છે. જો $f(x)$ એ α આગળ મહત્તમ કિંમત મેળવે
અને $g(x)$ એ β આગળ ન્યૂનતમ કિંમત મેળવે તો

$$\lim_{x \rightarrow -\alpha\beta} \frac{(x-1)(x^2 - 5x + 6)}{x^2 - 6x + 8} = \underline{\hspace{2cm}}$$

છે.

Options :

1. $1/2$

2. $-1/2$

3. $3/2$

4. $-3/2$

Question Number : 74 Question Type : MCQ Option Shuffling : Yes Display Question Number : Yes Single Line Question Option : No Option Orientation : Vertical

Correct Marks : 4 Wrong Marks : 1

Let $\alpha \in (0, \pi/2)$ be fixed. If the integral

$$\int \frac{\tan x + \tan \alpha}{\tan x - \tan \alpha} dx =$$

$A(x) \cos 2\alpha + B(x) \sin 2\alpha + C$, where C is a
constant of integration, then the functions
 $A(x)$ and $B(x)$ are respectively :

Options :

1. $x - \alpha$ and $\log_e |\sin(x - \alpha)|$

2. $x + \alpha$ and $\log_e |\sin(x - \alpha)|$

3. $x - \alpha$ and $\log_e |\cos(x - \alpha)|$

4. $x + \alpha$ and $\log_e |\sin(x + \alpha)|$

Note: For this question, ambiguity is found in question/answer. Candidate will get full marks for this question if any of the correct options are chosen.

Question Number : 74 Question Type : MCQ Option Shuffling : Yes Display Question Number : Yes Single Line Question Option : No Option Orientation : Vertical

Correct Marks : 4 Wrong Marks : 1

माना $\alpha \in (0, \pi/2)$ दिया है। यदि समाकल

$$\int \frac{\tan x + \tan \alpha}{\tan x - \tan \alpha} dx =$$

$A(x) \cos 2\alpha + B(x) \sin 2\alpha + C$, जहाँ C एक समाकलन अचर है, तो फलन $A(x)$ तथा $B(x)$ क्रमशः हैं :

Options :

1. $x - \alpha$ और $\log_e |\sin(x - \alpha)|$

2. $x + \alpha$ और $\log_e |\sin(x - \alpha)|$

3. $x - \alpha$ और $\log_e |\cos(x - \alpha)|$

4. $x + \alpha$ और $\log_e |\sin(x + \alpha)|$

Note: For this question, ambiguity is found in question/answer. Candidate will get full marks for this question if any of the correct options are chosen.

Question Number : 74 Question Type : MCQ Option Shuffling : Yes Display Question Number : Yes Single Line Question Option : No Option Orientation : Vertical

Correct Marks : 4 Wrong Marks : 1

ધારો કે $\alpha \in (0, \pi/2)$ નિશ્ચિત કરવામાં આવે છે. જો

$$\text{સંકલિત } \int \frac{\tan x + \tan \alpha}{\tan x - \tan \alpha} dx =$$

$A(x) \cos 2\alpha + B(x) \sin 2\alpha + C$, જ્યાં C એ સંકલનનો અચળાંક છે, તો વિધેયો $A(x)$ અને $B(x)$ અનુક્રમે _____ છે.

Options :

1. $x - \alpha$ અને $\log_e |\sin(x - \alpha)|$

2. $x + \alpha$ અને $\log_e |\sin(x - \alpha)|$

3. $x - \alpha$ અને $\log_e |\cos(x - \alpha)|$

4. $x + \alpha$ અને $\log_e |\sin(x + \alpha)|$

Note: For this question, ambiguity is found in question/answer. Candidate will get full marks for this question if any of the correct options are chosen.

Question Number : 75 Question Type : MCQ Option Shuffling : Yes Display Question Number : Yes Single Line Question Option : No Option Orientation : Vertical

Correct Marks : 4 Wrong Marks : 1

A value of α such that

$$\int_{\alpha}^{\alpha+1} \frac{dx}{(x+\alpha)(x+\alpha+1)} = \log_e \left(\frac{9}{8} \right) \text{ is :}$$

Options :

1. $\frac{1}{2}$
2. 2
3. -2
4. $-\frac{1}{2}$

Question Number : 75 Question Type : MCQ Option Shuffling : Yes Display Question Number : Yes Single Line Question Option : No Option Orientation : Vertical

Correct Marks : 4 Wrong Marks : 1

α का एक मान, जिसके लिए

$$\int_{\alpha}^{\alpha+1} \frac{dx}{(x+\alpha)(x+\alpha+1)} = \log_e \left(\frac{9}{8} \right) \text{ है, है :}$$

Options :

1. $\frac{1}{2}$
2. 2
3. -2
4. $-\frac{1}{2}$

Question Number : 75 Question Type : MCQ Option Shuffling : Yes Display Question Number : Yes Single Line Question Option : No Option Orientation : Vertical

Correct Marks : 4 Wrong Marks : 1

α नी कर्क किमत मारे

$$\int_{\alpha}^{\alpha+1} \frac{dx}{(x+\alpha)(x+\alpha+1)} = \log_e \left(\frac{9}{8} \right) \text{ थय ?}$$

Options :

1. $\frac{1}{2}$
2. 2
3. -2
4. $-\frac{1}{2}$

Question Number : 76 Question Type : MCQ Option Shuffling : Yes Display Question Number : Yes Single Line Question Option : No Option Orientation : Vertical

Correct Marks : 4 Wrong Marks : 1

If the area (in sq. units) bounded by the parabola $y^2 = 4\lambda x$ and the line $y = \lambda x$,

$\lambda > 0$, is $\frac{1}{9}$, then λ is equal to :

Options :

1. $4\sqrt{3}$
2. $2\sqrt{6}$
3. 24
4. 48

Question Number : 76 Question Type : MCQ Option Shuffling : Yes Display Question Number : Yes Single Line Question Option : No Option Orientation : Vertical

Correct Marks : 4 Wrong Marks : 1

यदि परवलय $y^2 = 4\lambda x$ तथा रेखा $y = \lambda x$,

$\lambda > 0$, से घिरे क्षेत्र का क्षेत्रफल (वर्ग इकाइयों में) $\frac{1}{9}$

है, तो λ बराबर है :

Options :

1. $4\sqrt{3}$

2. $2\sqrt{6}$

3. 24

4. 48

Question Number : 76 Question Type : MCQ Option Shuffling : Yes Display Question Number : Yes Single Line Question Option : No Option Orientation : Vertical

Correct Marks : 4 Wrong Marks : 1

જો પરવલય $y^2 = 4\lambda x$ અને રેખા $y = \lambda x$,

$\lambda > 0$, દ્વારા ઘેરાયેલ પ્રદેશનું ક્ષેત્રફળ (ચો.એકમમાં) $\frac{1}{9}$

હોય તો λ બરાબર _____ છે.

Options :

1. $4\sqrt{3}$

2. $2\sqrt{6}$

3. 24

4. 48

Question Number : 77 Question Type : MCQ Option Shuffling : Yes Display Question Number : Yes Single Line Question Option : No Option Orientation : Vertical

Correct Marks : 4 Wrong Marks : 1

The general solution of the differential equation $(y^2 - x^3) dx - xy dy = 0$ ($x \neq 0$) is :

(where c is a constant of integration)

Options :

1. $y^2 + 2x^2 + cx^3 = 0$

2. $y^2 - 2x^3 + cx^2 = 0$

3. $y^2 + 2x^3 + cx^2 = 0$

4. $y^2 - 2x^2 + cx^3 = 0$

Question Number : 77 Question Type : MCQ Option Shuffling : Yes Display Question Number : Yes Single Line Question Option : No Option Orientation : Vertical

Correct Marks : 4 Wrong Marks : 1

अवकल समीकरण $(y^2 - x^3) dx - xy dy = 0$

$(x \neq 0)$ का व्यापक हल है :

(जहाँ c एक समाकलन अचर है)

Options :

1. $y^2 + 2x^2 + cx^3 = 0$

2. $y^2 - 2x^3 + cx^2 = 0$

3. $y^2 + 2x^3 + cx^2 = 0$

4. $y^2 - 2x^2 + cx^3 = 0$

Question Number : 77 Question Type : MCQ Option Shuffling : Yes Display Question Number : Yes Single Line Question Option : No Option Orientation : Vertical

Correct Marks : 4 Wrong Marks : 1

विकल समीकरण $(y^2 - x^3) dx - xy dy = 0$ ($x \neq 0$)

નો વ્યાપક ઉકલ _____ છે.

(જ્યાં c એ સંકલનનો અચળાંક છે)

Options :

1. $y^2 + 2x^2 + cx^3 = 0$

2. $y^2 - 2x^3 + cx^2 = 0$

3. $y^2 + 2x^3 + cx^2 = 0$

4. $y^2 - 2x^2 + cx^3 = 0$

Question Number : 78 Question Type : MCQ Option Shuffling : Yes Display Question Number : Yes Single Line Question Option : No Option Orientation : Vertical

Correct Marks : 4 Wrong Marks : 1

A straight line L at a distance of 4 units from the origin makes positive intercepts on the coordinate axes and the perpendicular from the origin to this line makes an angle of 60° with the line $x + y = 0$. Then an equation of the line L is :

Options :

1. $(\sqrt{3} + 1)x + (\sqrt{3} - 1)y = 8\sqrt{2}$

2. $(\sqrt{3} - 1)x + (\sqrt{3} + 1)y = 8\sqrt{2}$

3. $\sqrt{3}x + y = 8$

4. $x + \sqrt{3}y = 8$

Note: For this question, ambiguity is found in question/answer. Candidate will get full marks for this question if any of the correct options are chosen.

Question Number : 78 Question Type : MCQ Option Shuffling : Yes Display Question Number : Yes Single Line Question Option : No Option Orientation : Vertical

Correct Marks : 4 Wrong Marks : 1

मूलबिन्दु से 4 इकाई की दूरी पर एक सरल रेखा L निर्देशांक अक्षों पर धनात्मक अंतःखण्ड बनाती है तथा मूलबिन्दु से इस रेखा पर लंब, रेखा $x + y = 0$ के साथ 60° का कोण बनाता है। तो रेखा L का एक समीकरण है :

Options :

1. $(\sqrt{3} + 1)x + (\sqrt{3} - 1)y = 8\sqrt{2}$

2. $(\sqrt{3} - 1)x + (\sqrt{3} + 1)y = 8\sqrt{2}$

3. $\sqrt{3}x + y = 8$

4. $x + \sqrt{3}y = 8$

Note: For this question, ambiguity is found in question/answer. Candidate will get full marks for this question if any of the correct options are chosen.

Question Number : 78 Question Type : MCQ Option Shuffling : Yes Display Question Number : Yes Single Line Question Option : No Option Orientation : Vertical

Correct Marks : 4 Wrong Marks : 1

ઊગમબિંદુથી 4 એકમના અંતરે આવેલી એક રેખા L, યામાક્ષો પર ધન અંતઃખંડો બનાવે છે અને ઊગમબિંદુથી આ રેખા પરનો લંબ, રેખા $x + y = 0$ સાથે 60° નો ખૂણો બનાવે છે. તો રેખા L નું એક સમીકરણ _____ છે.

Options :

1. $(\sqrt{3} + 1)x + (\sqrt{3} - 1)y = 8\sqrt{2}$

2. $(\sqrt{3} - 1)x + (\sqrt{3} + 1)y = 8\sqrt{2}$

3. $\sqrt{3}x + y = 8$

4. $x + \sqrt{3}y = 8$

Note: For this question, ambiguity is found in question/answer. Candidate will get full marks for this question if any of the correct options are chosen.

Question Number : 79 Question Type : MCQ Option Shuffling : Yes Display Question Number : Yes Single Line Question Option : No Option Orientation : Vertical

Correct Marks : 4 Wrong Marks : 1

A triangle has a vertex at $(1, 2)$ and the mid points of the two sides through it are $(-1, 1)$ and $(2, 3)$. Then the centroid of this triangle is :

Options :

1. $\left(\frac{1}{3}, 1\right)$

2. $\left(\frac{1}{3}, 2\right)$

3. $\left(1, \frac{7}{3}\right)$

4. $\left(\frac{1}{3}, \frac{5}{3}\right)$

Question Number : 79 Question Type : MCQ Option Shuffling : Yes Display Question Number : Yes Single Line Question Option : No Option Orientation : Vertical

Correct Marks : 4 Wrong Marks : 1

एक त्रिभुज का एक शीर्ष $(1, 2)$ पर है तथा इससे होकर जाने वाली दो भुजाओं के मध्य-बिन्दु $(-1, 1)$ और $(2, 3)$ हैं। तो इस त्रिभुज का केन्द्रक है :

Options :

1. $\left(\frac{1}{3}, 1\right)$

2. $\left(\frac{1}{3}, 2\right)$

3. $\left(1, \frac{7}{3}\right)$

4. $\left(\frac{1}{3}, \frac{5}{3}\right)$

Question Number : 79 Question Type : MCQ Option Shuffling : Yes Display Question Number : Yes Single Line Question Option : No Option Orientation : Vertical

Correct Marks : 4 Wrong Marks : 1

કોઈ ત્રિકોણનું એક શિરોબિંદુ $(1, 2)$ આગળ છે અને તેમાંથી પસાર થતી બે બાજુઓના મધ્યબિંદુઓ $(-1, 1)$ અને $(2, 3)$ છે. તો આ ત્રિકોણનું મધ્યકેન્દ્ર _____ છે.

Options :

1. $\left(\frac{1}{3}, 1\right)$

2. $\left(\frac{1}{3}, 2\right)$

3. $\left(1, \frac{7}{3}\right)$

4. $\left(\frac{1}{3}, \frac{5}{3}\right)$

Question Number : 80 Question Type : MCQ Option Shuffling : Yes Display Question Number : Yes Single Line Question Option : No Option Orientation : Vertical

Correct Marks : 4 Wrong Marks : 1

A circle touching the x -axis at $(3, 0)$ and making an intercept of length 8 on the y -axis passes through the point :

Options :

1. $(3, 10)$

2. $(3, 5)$

3. $(1, 5)$

4. $(2, 3)$

Question Number : 80 Question Type : MCQ Option Shuffling : Yes Display Question Number : Yes Single Line Question Option : No Option Orientation : Vertical

Correct Marks : 4 Wrong Marks : 1

x -अक्ष को $(3, 0)$ पर स्पर्श करता हुआ तथा y -अक्ष पर 8 लम्बाई का अंतःखण्ड (intercept) बनाता हुआ एक वृत्त निम्न में से किस बिन्दु से होकर जाता है?

Options :

1. $(3, 10)$
2. $(3, 5)$
3. $(1, 5)$
4. $(2, 3)$

Question Number : 80 Question Type : MCQ Option Shuffling : Yes Display Question Number : Yes Single Line Question Option : No Option Orientation : Vertical

Correct Marks : 4 Wrong Marks : 1

x -अक्षने $(3, 0)$ अगण स्पर्शतुं अने y -अक्ष पर 8 लंबाईनो अंतःखंड बनावतुं वरतुण _____ बिंदुमांथी पसार थरो.

Options :

1. $(3, 10)$
2. $(3, 5)$
3. $(1, 5)$
4. $(2, 3)$

Question Number : 81 Question Type : MCQ Option Shuffling : Yes Display Question Number : Yes Single Line Question Option : No Option Orientation : Vertical

Correct Marks : 4 Wrong Marks : 1

The equation of a common tangent to the curves, $y^2 = 16x$ and $xy = -4$, is :

Options :

1. $x - 2y + 16 = 0$
2. $x + y + 4 = 0$
3. $2x - y + 2 = 0$
4. $x - y + 4 = 0$

Question Number : 81 Question Type : MCQ Option Shuffling : Yes Display Question Number : Yes Single Line Question Option : No Option Orientation : Vertical

Correct Marks : 4 Wrong Marks : 1

वक्रों $y^2 = 16x$ तथा $xy = -4$ की एक उभयनिष्ठ स्पर्शरेखा का समीकरण है :

Options :

1. $x - 2y + 16 = 0$
2. $x + y + 4 = 0$
3. $2x - y + 2 = 0$
4. $x - y + 4 = 0$

Question Number : 81 Question Type : MCQ Option Shuffling : Yes Display Question Number : Yes Single Line Question Option : No Option Orientation : Vertical

Correct Marks : 4 Wrong Marks : 1

वक्रों $y^2 = 16x$ અને $xy = -4$ ના સામાન્ય સ્પર્શકનું સમીકરણ _____ છે.

Options :

1. $x - 2y + 16 = 0$
2. $x + y + 4 = 0$
3. $2x - y + 2 = 0$
4. $x - y + 4 = 0$

Question Number : 82 Question Type : MCQ Option Shuffling : Yes Display Question Number : Yes Single Line Question Option : No Option Orientation : Vertical

Correct Marks : 4 Wrong Marks : 1

An ellipse, with foci at $(0, 2)$ and $(0, -2)$ and minor axis of length 4, passes through which of the following points ?

Options :

1. $(2, \sqrt{2})$
2. $(1, 2\sqrt{2})$

3. $(\sqrt{2}, 2)$

4. $(2, 2\sqrt{2})$

Question Number : 82 Question Type : MCQ Option Shuffling : Yes Display Question Number : Yes Single Line Question Option : No Option Orientation : Vertical

Correct Marks : 4 Wrong Marks : 1

एक दीर्घवृत्त, जिसकी नाभियाँ $(0, 2)$ तथा $(0, -2)$ पर हैं तथा जिसके लघु अक्ष की लम्बाई 4 है, निम्न में से किस बिन्दु से होकर जाता है?

Options :

1. $(2, \sqrt{2})$

2. $(1, 2\sqrt{2})$

3. $(\sqrt{2}, 2)$

4. $(2, 2\sqrt{2})$

Question Number : 82 Question Type : MCQ Option Shuffling : Yes Display Question Number : Yes Single Line Question Option : No Option Orientation : Vertical

Correct Marks : 4 Wrong Marks : 1

$(0, 2)$ અને $(0, -2)$ આગળ નાભિઓ અને ગોણ અક્ષની લંબાઈ 4 વાળો ઉપવલય નીચેના પૈકી કયા બિંદુમાંથી પસાર થશે?

Options :

1. $(2, \sqrt{2})$

2. $(1, 2\sqrt{2})$

3. $(\sqrt{2}, 2)$

4. $(2, 2\sqrt{2})$

Question Number : 83 Question Type : MCQ Option Shuffling : Yes Display Question Number : Yes Single Line Question Option : No Option Orientation : Vertical

Correct Marks : 4 Wrong Marks : 1

A plane which bisects the angle between the two given planes $2x - y + 2z - 4 = 0$ and $x + 2y + 2z - 2 = 0$, passes through the point :

Options :

1. $(1, -4, 1)$
2. $(2, 4, 1)$
3. $(2, -4, 1)$
4. $(1, 4, -1)$

Question Number : 83 Question Type : MCQ Option Shuffling : Yes Display Question Number : Yes Single Line Question Option : No Option Orientation : Vertical

Correct Marks : 4 Wrong Marks : 1

दो दिए गए समतलों $2x - y + 2z - 4 = 0$ तथा $x + 2y + 2z - 2 = 0$ के बीच के कोण को समद्विभाजित करता एक समतल, निम्न में से किस बिन्दु से होकर जाता है?

Options :

1. $(1, -4, 1)$
2. $(2, 4, 1)$
3. $(2, -4, 1)$
4. $(1, 4, -1)$

Question Number : 83 Question Type : MCQ Option Shuffling : Yes Display Question Number : Yes Single Line Question Option : No Option Orientation : Vertical

Correct Marks : 4 Wrong Marks : 1

आपेला ढे समतलो $2x - y + 2z - 4 = 0$ अने $x + 2y + 2z - 2 = 0$ वर्येना भूषाने दुभागतुं समतल _____ बिंदुमांथी पसार थरो.

Options :

1. $(1, -4, 1)$
2. $(2, 4, 1)$

3. $(2, -4, 1)$

4. $(1, 4, -1)$

Question Number : 84 Question Type : MCQ Option Shuffling : Yes Display Question Number : Yes Single Line Question Option : No Option Orientation : Vertical

Correct Marks : 4 Wrong Marks : 1

The length of the perpendicular drawn from the point $(2, 1, 4)$ to the plane containing the lines

$$\vec{r} = (\hat{i} + \hat{j}) + \lambda(\hat{i} + 2\hat{j} - \hat{k}) \quad \text{and}$$

$$\vec{r} = (\hat{i} + \hat{j}) + \mu(-\hat{i} + \hat{j} - 2\hat{k}) \text{ is :}$$

Options :

1. 3

2. $\sqrt{3}$

3. $\frac{1}{3}$

4. $\frac{1}{\sqrt{3}}$

Question Number : 84 Question Type : MCQ Option Shuffling : Yes Display Question Number : Yes Single Line Question Option : No Option Orientation : Vertical

Correct Marks : 4 Wrong Marks : 1

रेखाओं $\vec{r} = (\hat{i} + \hat{j}) + \lambda(\hat{i} + 2\hat{j} - \hat{k})$ तथा

$\vec{r} = (\hat{i} + \hat{j}) + \mu(-\hat{i} + \hat{j} - 2\hat{k})$ को अंतर्विष्ट

करते समतल पर बिन्दु $(2, 1, 4)$ से डाले गये लम्ब की लम्बाई है :

Options :

1. 3

2. $\sqrt{3}$

3. $\frac{1}{3}$

4. $\frac{1}{\sqrt{3}}$

Question Number : 84 Question Type : MCQ Option Shuffling : Yes Display Question Number : Yes Single Line Question Option : No Option Orientation : Vertical

Correct Marks : 4 Wrong Marks : 1

રેખાઓ $\vec{r} = (\hat{i} + \hat{j}) + \lambda(\hat{i} + 2\hat{j} - \hat{k})$ અને

$\vec{r} = (\hat{i} + \hat{j}) + \mu(-\hat{i} + \hat{j} - 2\hat{k})$ ને સમાવતા સમતલ પર બિંદુ $(2, 1, 4)$ થી દોરેલ લંબની લંબાઈ _____ છે.

Options :

1. 3
2. $\sqrt{3}$
3. $\frac{1}{3}$
4. $\frac{1}{\sqrt{3}}$

Question Number : 85 Question Type : MCQ Option Shuffling : Yes Display Question Number : Yes Single Line Question Option : No Option Orientation : Vertical

Correct Marks : 4 Wrong Marks : 1

Let $\alpha \in \mathbb{R}$ and the three vectors

$$\vec{a} = \alpha\hat{i} + \hat{j} + 3\hat{k}, \quad \vec{b} = 2\hat{i} + \hat{j} - \alpha\hat{k}$$

and $\vec{c} = \alpha\hat{i} - 2\hat{j} + 3\hat{k}$. Then the set

$$S = \{\alpha : \vec{a}, \vec{b} \text{ and } \vec{c} \text{ are coplanar}\}$$

Options :

1. is empty
2. is singleton
3. contains exactly two positive numbers

contains exactly two numbers only
one of which is positive

4.

Question Number : 85 Question Type : MCQ Option Shuffling : Yes Display Question Number : Yes Single Line Question Option : No Option Orientation : Vertical

Correct Marks : 4 Wrong Marks : 1

માના $\alpha \in \mathbb{R}$ તથા ત્રીણ સદિશ $\vec{a} = \alpha \hat{i} + \hat{j} + 3\hat{k}$,

$\vec{b} = 2\hat{i} + \hat{j} - \alpha\hat{k}$ ઓર

$\vec{c} = \alpha\hat{i} - 2\hat{j} + 3\hat{k}$ હૈં । તો સમુચ્ચય

$S = \{\alpha : \vec{a}, \vec{b} \text{ ઓર } \vec{c} \text{ સમતલીય હૈં}\}$

Options :

1. રિક્ત હૈં ।
2. ઁકલ હૈં ।
3. મૈં તથ્યતઃ (exactly) ઢો ઢનાત્મક સંખ્યાયૈં હૈં ।
4. મૈં તથ્યતઃ ઢો સંખ્યાયૈં હૈં જિનમૈં સે કેવલ ઁક ઢનાત્મક હૈં ।

Question Number : 85 Question Type : MCQ Option Shuffling : Yes Display Question Number : Yes Single Line Question Option : No Option Orientation : Vertical

Correct Marks : 4 Wrong Marks : 1

ઢારો કે $\alpha \in \mathbb{R}$ છે તથા $\vec{a} = \alpha \hat{i} + \hat{j} + 3\hat{k}$,

$\vec{b} = 2\hat{i} + \hat{j} - \alpha\hat{k}$ ઁને

$\vec{c} = \alpha\hat{i} - 2\hat{j} + 3\hat{k}$ ત્રણ સદિશો છે. તો ગણ

$S = \{\alpha : \vec{a}, \vec{b} \text{ ઁને } \vec{c} \text{ સમતલીય છે}\}$

Options :

1. ખાલી ગણ છે.
2. ઁકઢકી છે.
3. ફક્ત બે ઢન સંખ્યાઓ ઢરાવે છે.

ફક્ત બે સંખ્યાઓ ધરાવે છે જેમાંની એક જ ધન

4. છે.

Question Number : 86 Question Type : MCQ Option Shuffling : Yes Display Question Number : Yes Single Line Question Option : No Option Orientation : Vertical

Correct Marks : 4 Wrong Marks : 1

A person throws two fair dice. He wins Rs. 15 for throwing a doublet (same numbers on the two dice), wins Rs. 12 when the throw results in the sum of 9, and loses Rs. 6 for any other outcome on the throw. Then the expected gain/loss (in Rs.) of the person is :

Options :

1. 2 gain

2. $\frac{1}{2}$ loss

3. $\frac{1}{2}$ gain

4. $\frac{1}{4}$ loss

Question Number : 86 Question Type : MCQ Option Shuffling : Yes Display Question Number : Yes Single Line Question Option : No Option Orientation : Vertical

Correct Marks : 4 Wrong Marks : 1

एक व्यक्ति दो न्याय्य (fair) पासे उछालता है। एक द्विक (दोनों पासों पर एक ही संख्या) आने पर वह रु. 15 जीतता है, दोनों पासों पर आए अंकों का योग 9 होने पर रु. 12 जीतता है तथा किसी अन्य परिणाम (outcome) पर रु. 6 हारता है। तो उस व्यक्ति का प्रत्याशित (expected) लाभ/हानि (रु.में) है :

Options :

1. लाभ 2

2. हानि $\frac{1}{2}$

3. લાભ $\frac{1}{2}$

4. હાનિ $\frac{1}{4}$

Question Number : 86 Question Type : MCQ Option Shuffling : Yes Display Question Number : Yes Single Line Question Option : No Option Orientation : Vertical

Correct Marks : 4 Wrong Marks : 1

એક વ્યક્તિ બે સમતોલ પાસાને ઉછાળે છે. બંને પાસા પર સમાન અંક આવે તો તે 15 રૂપિયા જીતે, અંકોનો સરવાળો 9 આવે ત્યારે 12 રૂપિયા જીતે અને અન્ય પરિણામ આવે તો 6 રૂપિયા હારે છે. તો આ વ્યક્તિનો અપેક્ષિત નફો/ખોટ (રૂપિયામાં) _____ છે.

Options :

1. 2 નફો

2. $\frac{1}{2}$ ખોટ

3. $\frac{1}{2}$ નફો

4. $\frac{1}{4}$ ખોટ

Question Number : 87 Question Type : MCQ Option Shuffling : Yes Display Question Number : Yes Single Line Question Option : No Option Orientation : Vertical

Correct Marks : 4 Wrong Marks : 1

For an initial screening of an admission test, a candidate is given fifty problems to solve. If the probability that the candidate can solve any problem is $\frac{4}{5}$, then the probability that he is unable to solve less than two problems is :

Options :

1. $\frac{201}{5} \left(\frac{1}{5}\right)^{49}$

2. $\frac{54}{5} \left(\frac{4}{5}\right)^{49}$

3. $\frac{316}{25} \left(\frac{4}{5}\right)^{48}$

4. $\frac{164}{25} \left(\frac{1}{5}\right)^{48}$

Question Number : 87 Question Type : MCQ Option Shuffling : Yes Display Question Number : Yes Single Line Question Option : No Option Orientation : Vertical

Correct Marks : 4 Wrong Marks : 1

प्रारंभिक जाँच के लिए एक प्रवेश परीक्षा में एक परीक्षार्थी को पचास प्रश्न हल करने के लिए दिए गए हैं। यदि परीक्षार्थी के किसी एक प्रश्न को हल कर सकने की प्रायिकता $\frac{4}{5}$ है, तो उसके दो से कम प्रश्नों को हल करने में असमर्थ होने की प्रायिकता है :

Options :

1. $\frac{201}{5} \left(\frac{1}{5}\right)^{49}$

2. $\frac{54}{5} \left(\frac{4}{5}\right)^{49}$

3. $\frac{316}{25} \left(\frac{4}{5}\right)^{48}$

4. $\frac{164}{25} \left(\frac{1}{5}\right)^{48}$

Question Number : 87 Question Type : MCQ Option Shuffling : Yes Display Question Number : Yes Single Line Question Option : No Option Orientation : Vertical

Correct Marks : 4 Wrong Marks : 1

कोईक प्रवेश परीक्षानी प्राथमिक पसंदगी माटे उभेदवारने पचास प्रश्नो उकेलवा माटे आपेल छे. जे उभेदवार कोई अेक प्रश्न उकेली शके तेनी संभावना $\frac{4}{5}$ होय तो ते बेथी ओछा प्रश्नो उकेलवामां असमर्थ रहे तेनी संभावना केटली?

Options :

1. $\frac{201}{5} \left(\frac{1}{5}\right)^{49}$

2. $\frac{54}{5} \left(\frac{4}{5}\right)^{49}$

3. $\frac{316}{25} \left(\frac{4}{5}\right)^{48}$

4. $\frac{164}{25} \left(\frac{1}{5}\right)^{48}$

Question Number : 88 Question Type : MCQ Option Shuffling : Yes Display Question Number : Yes Single Line Question Option : No Option Orientation : Vertical

Correct Marks : 4 Wrong Marks : 1

Let S be the set of all $\alpha \in \mathbb{R}$ such that the equation, $\cos 2x + \alpha \sin x = 2\alpha - 7$ has a solution. Then S is equal to :

Options :

1. \mathbb{R}
2. $[2, 6]$
3. $[1, 4]$
4. $[3, 7]$

Question Number : 88 Question Type : MCQ Option Shuffling : Yes Display Question Number : Yes Single Line Question Option : No Option Orientation : Vertical

Correct Marks : 4 Wrong Marks : 1

माना सभी $\alpha \in \mathbb{R}$, जिसके लिए समीकरण $\cos 2x + \alpha \sin x = 2\alpha - 7$ का एक हल है, का समुच्चय S है। तो S बराबर है :

Options :

1. \mathbb{R}
2. $[2, 6]$
3. $[1, 4]$

4. [3, 7]

Question Number : 88 Question Type : MCQ Option Shuffling : Yes Display Question Number : Yes Single Line Question Option : No Option Orientation : Vertical

Correct Marks : 4 Wrong Marks : 1

ધારો કે S એ એવા તમામ $\alpha \in \mathbb{R}$ નો ગણ છે કે જેથી સમીકરણ $\cos 2x + \alpha \sin x = 2\alpha - 7$ ને ઉકેલ હોય, તો S બરાબર _____ છે.

Options :

1. \mathbb{R}
2. [2, 6]
3. [1, 4]
4. [3, 7]

Question Number : 89 Question Type : MCQ Option Shuffling : Yes Display Question Number : Yes Single Line Question Option : No Option Orientation : Vertical

Correct Marks : 4 Wrong Marks : 1

The angle of elevation of the top of a vertical tower standing on a horizontal plane is observed to be 45° from a point A on the plane. Let B be the point 30 m vertically above the point A. If the angle of elevation of the top of the tower from B be 30° , then the distance (in m) of the foot of the tower from the point A is :

Options :

1. $15(3 - \sqrt{3})$
2. $15(3 + \sqrt{3})$
3. $15(1 + \sqrt{3})$
4. $15(5 - \sqrt{3})$

Question Number : 89 Question Type : MCQ Option Shuffling : Yes Display Question Number : Yes Single Line Question Option : No Option Orientation : Vertical

Correct Marks : 4 Wrong Marks : 1

क्षैतिज तल पर खड़ी एक उर्ध्वाधर मीनार के शिखर का तल पर एक बिन्दु A से उन्नयन कोण 45° है। माना बिन्दु A से 30 मीटर उर्ध्वाधर ऊपर बिन्दु B है। यदि B से मीनार के शिखर का उन्नयन कोण 30° है, तो मीनार के पाद की बिन्दु A से दूरी (मीटर में) है :

Options :

1. $15(3 - \sqrt{3})$
2. $15(3 + \sqrt{3})$
3. $15(1 + \sqrt{3})$
4. $15(5 - \sqrt{3})$

Question Number : 89 Question Type : MCQ Option Shuffling : Yes Display Question Number : Yes Single Line Question Option : No Option Orientation : Vertical

Correct Marks : 4 Wrong Marks : 1

समक्षितिज समतल पर उभेला एक शिरोलंब टावरनी टोचनो उत्सेधकोण आ समतल परना बिंदु A थी 45° बणाय छे. धारो के B अे बिंदु A नी उपर शिरोलंब दिशाभां 30 मीटर उंचाईअे आवेलुं बिंदु छे. जे B थी टावरना टोचनो उत्सेधकोण 30° होय, तो बिंदु A थी टावरना तणियानुं अंतर (मीटर भां) _____ छे.

Options :

1. $15(3 - \sqrt{3})$
2. $15(3 + \sqrt{3})$
3. $15(1 + \sqrt{3})$
4. $15(5 - \sqrt{3})$

Question Number : 90 Question Type : MCQ Option Shuffling : Yes Display Question Number : Yes Single Line Question Option : No Option Orientation : Vertical

Correct Marks : 4 Wrong Marks : 1

The Boolean expression $\sim(p \Rightarrow (\sim q))$ is equivalent to :

Options :

1. $(\sim p) \Rightarrow q$

2. $q \Rightarrow \sim p$

3. $p \wedge q$

4. $p \vee q$

Question Number : 90 Question Type : MCQ Option Shuffling : Yes Display Question Number : Yes Single Line Question Option : No Option Orientation : Vertical

Correct Marks : 4 Wrong Marks : 1

बूले का व्यंजक $\sim(p \Rightarrow (\sim q))$ निम्न में से किसके समतुल्य है?

Options :

1. $(\sim p) \Rightarrow q$

2. $q \Rightarrow \sim p$

3. $p \wedge q$

4. $p \vee q$

Question Number : 90 Question Type : MCQ Option Shuffling : Yes Display Question Number : Yes Single Line Question Option : No Option Orientation : Vertical

Correct Marks : 4 Wrong Marks : 1

बुलीयन निरूपण $\sim(p \Rightarrow (\sim q))$ એ _____ ને સમકક્ષ છે.

Options :

1. $(\sim p) \Rightarrow q$

2. $q \Rightarrow \sim p$

3. $p \wedge q$

4. $p \vee q$