

SESSION - 3

Graduate Aptitude Test in Engineering

Notations :

- Options shown in green color and with ✓ icon are correct.
- Options shown in red color and with ✗ icon are incorrect.

Question Paper Name: ME: MECHANICAL ENGINEERING 1st Feb shift2
Number of Questions: 65
Total Marks: 100.0

Wrong answer for MCQ will result in negative marks, (-1/3) for 1 mark Questions and (-2/3) for 2 marks Questions.

General Aptitude

Number of Questions: 10
Section Marks: 15.0

Q.1 to Q.5 carry 1 mark each & Q.6 to Q.10 carry 2 marks each.

Question Number : 1 Question Type : MCQ

Choose the appropriate word/phrase, out of the four options given below, to complete the following sentence:

Apparent lifelessness _____ dormant life.

- (A) harbours (B) leads to (C) supports (D) affects

Options :

- ✓ A
- ✗ B
- ✗ C
- ✗ D

Question Number : 2 Question Type : MCQ

Fill in the blank with the correct idiom/phrase.

That boy from the town was a _____ in the sleepy village.

- (A) dog out of herd (B) sheep from the heap
(C) fish out of water (D) bird from the flock

Options :

- ✗ A
- ✗ B
- ✓ C
- ✗ D

Question Number : 3 Question Type : MCQ

Choose the statement where underlined word is used correctly.

- (A) When the teacher eludes to different authors, he is being elusive.
- (B) When the thief keeps eluding the police, he is being elusive.
- (C) Matters that are difficult to understand, identify or remember are allusive.
- (D) Mirages can be allusive, but a better way to express them is illusory.

Options :

- 1. ✘ A
- 2. ✔ B
- 3. ✘ C
- 4. ✘ D

Question Number : 4 Question Type : MCQ

Tanya is older than Eric.

Cliff is older than Tanya.

Eric is older than Cliff.

If the first two statements are true, then the third statement is:

- (A) True
- (B) False
- (C) Uncertain
- (D) Data insufficient

Options :

- 1. ✘ A
- 2. ✔ B
- 3. ✘ C
- 4. ✘ D

Question Number : 5 Question Type : MCQ

Five teams have to compete in a league, with every team playing every other team exactly once, before going to the next round. How many matches will have to be held to complete the league round of matches?

- (A) 20
- (B) 10
- (C) 8
- (D) 5

Options :

- 1. ✘ A
- 2. ✔ B
- 3. ✘ C
- 4. ✘ D

Question Number : 6 Question Type : MCQ

Select the appropriate option in place of underlined part of the sentence.

Increased productivity necessary reflects greater efforts made by the employees.

- (A) Increase in productivity necessary
- (B) Increase productivity is necessary
- (C) Increase in productivity necessarily
- (D) No improvement required

Options :

- 1. ✘ A
- 2. ✘ B
- 3. ✔ C
- 4. ✘ D

Question Number : 7 Question Type : MCQ

Given below are two statements followed by two conclusions. Assuming these statements to be true, decide which one logically follows.

Statements:

- I. No manager is a leader.
- II. All leaders are executives.

Conclusions:

- I. No manager is an executive.
- II. No executive is a manager.

- (A) Only conclusion I follows.
- (B) Only conclusion II follows.
- (C) Neither conclusion I nor II follows.
- (D) Both conclusions I and II follow.

Options :

- 1. ✘ A
- 2. ✘ B
- 3. ✔ C
- 4. ✘ D

Question Number : 8 Question Type : NAT

In the given figure angle Q is a right angle, $PS:QS = 3:1$, $RT:QT = 5:2$ and $PU:UR = 1:1$. If area of triangle QTS is 20 cm^2 , then the area of triangle PQR in cm^2 is _____.

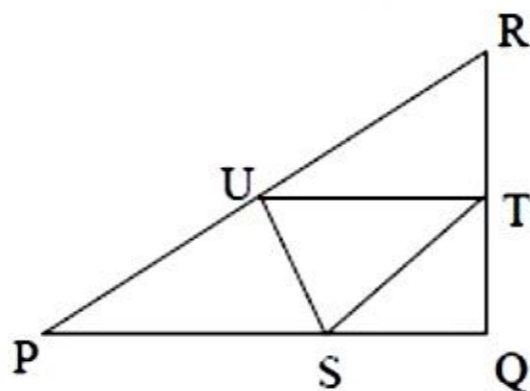

Correct Answer :

280

Question Number : 9 Question Type : MCQ

Right triangle PQR is to be constructed in the xy - plane so that the right angle is at P and line PR is parallel to the x -axis. The x and y coordinates of P, Q, and R are to be integers that satisfy the inequalities: $-4 \leq x \leq 5$ and $6 \leq y \leq 16$. How many different triangles could be constructed with these properties?

- (A) 110 (B) 1,100 (C) 9,900 (D) 10,000

Options :

1. ✘ A
2. ✘ B
3. ✔ C
4. ✘ D

Question Number : 10 Question Type : MCQ

A coin is tossed thrice. Let X be the event that head occurs in each of the first two tosses. Let Y be the event that a tail occurs on the third toss. Let Z be the event that two tails occur in three tosses. Based on the above information, which one of the following statements is TRUE?

- (A) X and Y are not independent (B) Y and Z are dependent
(C) Y and Z are independent (D) X and Z are independent

Options :

1. ✘ A
2. ✔ B
3. ✘ C
4. ✘ D

Mechanical Engineering

Number of Questions: 55
Section Marks: 85.0

Q.11 to Q.35 carry 1 mark each & Q.36 to Q.65 carry 2 marks each.

Question Number : 11 Question Type : MCQ

For the given fluctuating fatigue load, the values of stress amplitude and stress ratio are respectively

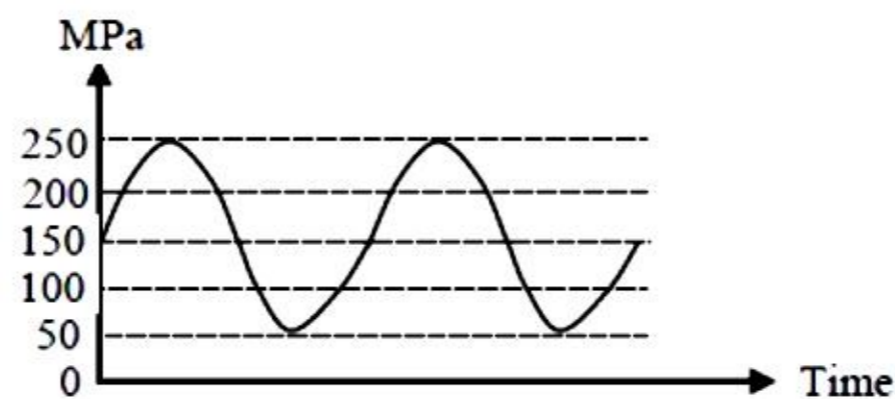

- (A) 100 MPa and 5 (B) 250 MPa and 5
(C) 100 MPa and 0.20 (D) 250 MPa and 0.20

Options :

1. ✘ A
2. ✘ B
3. ✔ C
4. ✘ D

Question Number : 12 Question Type : MCQ

For the same material and the mass, which of the following configurations of flywheel will have maximum mass moment of inertia about the axis of rotation OO' passing through the center of gravity.

(A) Solid Cylinder

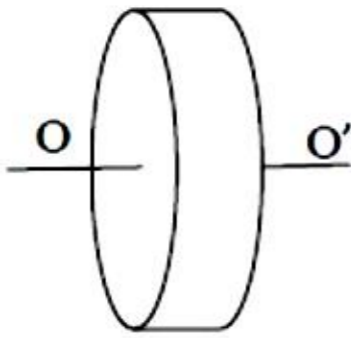

(B) Rimmed wheel

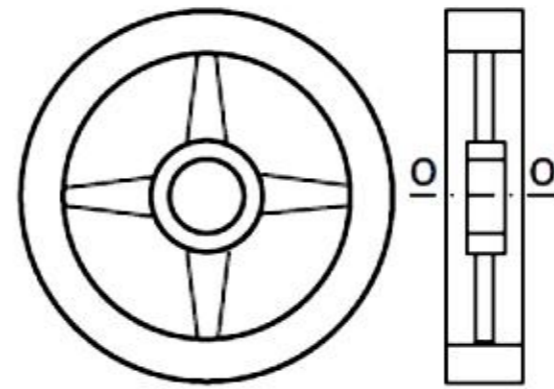

(C) Solid sphere

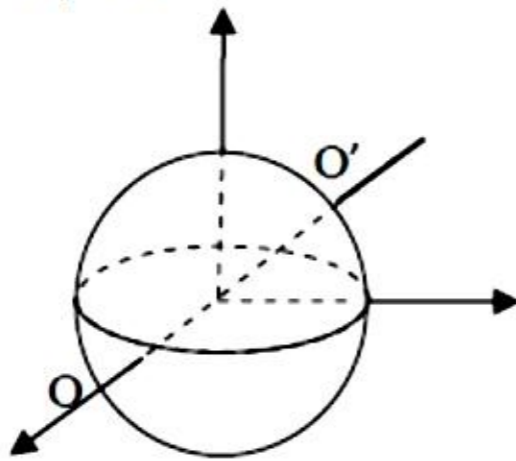

(D) Solid cube

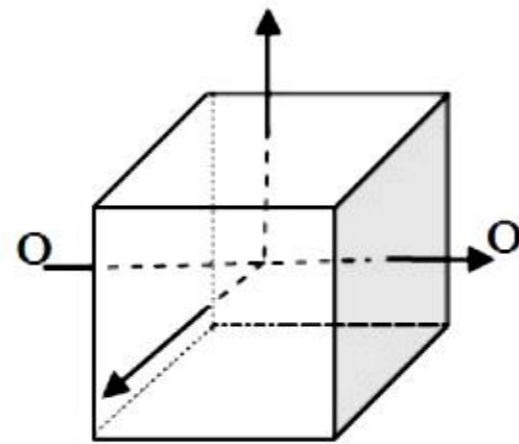

Options :

1. ✘ A
2. ✔ B
3. ✘ C
4. ✘ D

Question Number : 13 Question Type : MCQ

A gear train is made up of five spur gears as shown in the figure. Gear 2 is driver and gear 6 is driven member. N_2 , N_3 , N_4 , N_5 and N_6 represent number of teeth on gears 2, 3, 4, 5, and 6 respectively. The gear(s) which act(s) as idler(s) is/are

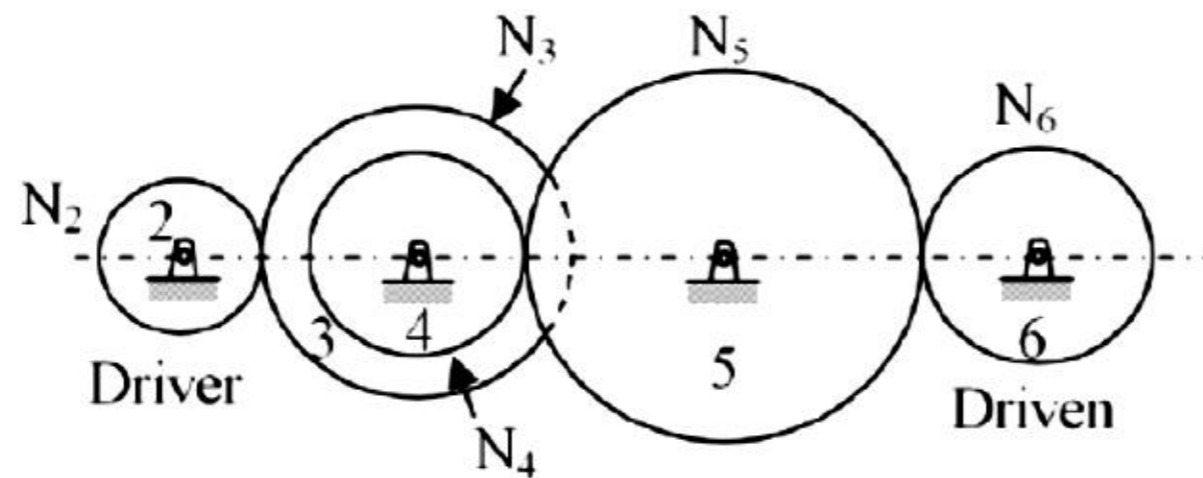

- (A) Only 3 (B) Only 4 (C) Only 5 (D) Both 3 and 5

Options :

1. ✘ A
2. ✘ B
3. ✔ C
4. ✘ D

Question Number : 14 Question Type : MCQ

In the figure, link 2 rotates with constant angular velocity ω_2 . A slider link 3 moves outwards with a constant relative velocity V_{QP} , where Q is a point on slider 3 and P is a point on link 2. The magnitude and direction of Coriolis component of acceleration is given by

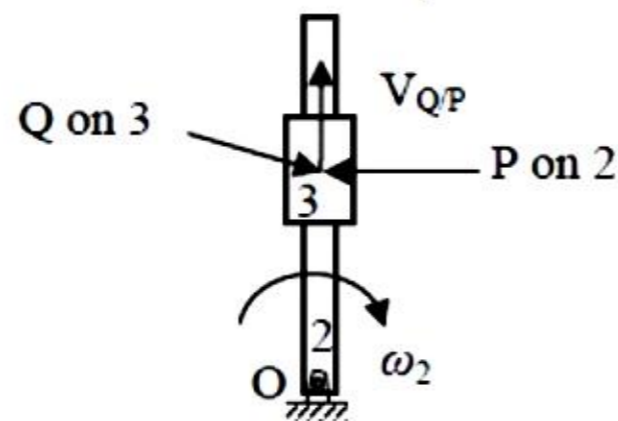

- (A) $2 \omega_2 V_{QP}$; direction of V_{QP} rotated by 90° in the direction of ω_2
 (B) $\omega_2 V_{QP}$; direction of V_{QP} rotated by 90° in the direction of ω_2
 (C) $2 \omega_2 V_{QP}$; direction of V_{QP} rotated by 90° opposite to the direction of ω_2
 (D) $\omega_2 V_{QP}$; direction of V_{QP} rotated by 90° opposite to the direction of ω_2

Options :

1. ✔ A
2. ✘ B
3. ✘ C
4. ✘ D

Question Number : 15 Question Type : MCQ

The strain hardening exponent n of stainless steel SS 304 with distinct yield and UTS values undergoing plastic deformation is

- (A) $n < 0$ (B) $n = 0$ (C) $0 < n < 1$ (D) $n = 1$

Options :

1. ✘ A
2. ✘ B
3. ✔ C
4. ✘ D

Question Number : 16 Question Type : MCQ

In a machining operation, if the generatrix and directrix both are straight lines, the surface obtained is

- (A) cylindrical (B) helical (C) plane (D) surface of revolution

Options :

1. ✘ A
2. ✘ B
3. ✔ C
4. ✘ D

Question Number : 17 Question Type : MCQ

In full mould (cavity-less) casting process, the pattern is made of

- (A) expanded polystyrene (B) wax
(C) epoxy (D) plaster of Paris

Options :

1. ✔ A
2. ✘ B
3. ✘ C
4. ✘ D

Question Number : 18 Question Type : MCQ

In the notation $(a/b/c) : (d/e/f)$ for summarizing the characteristics of queueing situation, the letters 'b' and 'd' stand respectively for

- (A) service time distribution and queue discipline
(B) number of servers and size of calling source
(C) number of servers and queue discipline
(D) service time distribution and maximum number allowed in system

Options :

1. ✔ A
2. ✘ B

3. ✖ C

4. ✖ D

Question Number : 19 Question Type : MCQ

Couette flow is characterized by

- (A) steady, incompressible, laminar flow through a straight circular pipe
- (B) fully developed turbulent flow through a straight circular pipe
- (C) steady, incompressible, laminar flow between two fixed parallel plates
- (D) steady, incompressible, laminar flow between one fixed plate and the other moving with a constant velocity

Options :

1. ✖ A

2. ✖ B

3. ✖ C

4. ✔ D

Question Number : 20 Question Type : MCQ

The thermodynamic cycle shown in figure ($T-s$ diagram) indicates

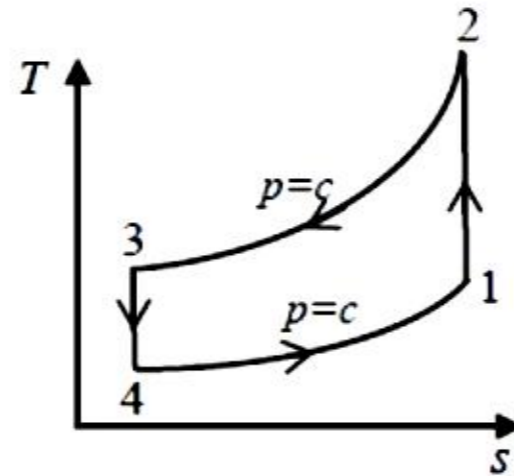

- (A) reversed Carnot cycle
- (B) reversed Brayton cycle
- (C) vapor compression cycle
- (D) vapor absorption cycle

Options :

1. ✖ A

2. ✔ B

3. ✖ C

4. ✖ D

Question Number : 21 Question Type : MCQ

The ratio of momentum diffusivity (ν) to thermal diffusivity (α), is called

- (A) Prandtl number
- (B) Nusselt number
- (C) Biot number
- (D) Lewis number

Options :

1. ✓ A
2. ✗ B
3. ✗ C
4. ✗ D

Question Number : 22 Question Type : MCQ

Saturated vapor is condensed to saturated liquid in a condenser. The heat capacity ratio is $C_r = \frac{C_{min}}{C_{max}}$. The effectiveness (ϵ) of the condenser is

- (A) $\frac{1 - \exp[-NTU(1+C_r)]}{1+C_r}$ (B) $\frac{1 - \exp[-NTU(1-C_r)]}{1-C_r \exp[-NTU(1-C_r)]}$
- (C) $\frac{NTU}{1+NTU}$ (D) $1 - \exp(-NTU)$

Options :

1. ✗ A
2. ✗ B
3. ✗ C
4. ✓ D

Question Number : 23 Question Type : NAT

Using a unit step size, the value of integral $\int_1^2 x \ln x \, dx$ by trapezoidal rule is _____

Correct Answer :

0.68 to 0.70

Question Number : 24 Question Type : MCQ

If $P(X) = 1/4$, $P(Y) = 1/3$, and $P(X \cap Y) = 1/12$, the value of $P(Y/X)$ is

- (A) $\frac{1}{4}$ (B) $\frac{4}{25}$ (C) $\frac{1}{3}$ (D) $\frac{29}{50}$

Options :

1. ✗ A
2. ✗ B
3. ✓ C
4. ✗ D

Question Number : 25 Question Type : NAT

The lowest eigenvalue of the 2×2 matrix $\begin{bmatrix} 4 & 2 \\ 1 & 3 \end{bmatrix}$ is _____

Correct Answer:

2

Question Number : 26 Question Type : NAT

The value of $\lim_{x \rightarrow 0} \left(\frac{-\sin x}{2 \sin x + x \cos x} \right)$ is _____

Correct Answer :

-0.35 to -0.30

Question Number : 27 Question Type : NAT

A cylindrical tank with closed ends is filled with compressed air at a pressure of 500 kPa. The inner radius of the tank is 2 m, and it has wall thickness of 10 mm. The magnitude of maximum in-plane shear stress (in MPa) is _____

Correct Answer :

25

Question Number : 28 Question Type : MCQ

A weight of 500 N is supported by two metallic ropes as shown in the figure. The values of tensions T_1 and T_2 are respectively

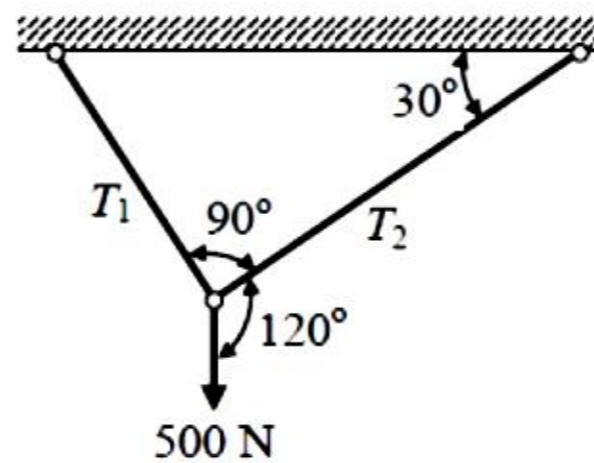

- (A) 433 N and 250 N
(C) 353.5 N and 250 N

- (B) 250 N and 433 N
(D) 250 N and 353.5 N

Options :

1. ✓ A
2. ✗ B
3. ✗ C
4. ✗ D

Question Number : 29 Question Type : MCQ

Which of the following statements are **TRUE** for damped vibrations?

- P. For a system having critical damping, the value of damping ratio is unity and system does not undergo a vibratory motion.
- Q. Logarithmic decrement method is used to determine the amount of damping in a physical system.
- R. In case of damping due to dry friction between moving surfaces resisting force of constant magnitude acts opposite to the relative motion.
- S. For the case of viscous damping, drag force is directly proportional to the square of relative velocity.

- (A) P and Q only
- (C) P, Q and R only

- (B) P and S only
- (D) Q and S only

Options :

- 1. ✘ A
- 2. ✘ B
- 3. ✔ C
- 4. ✘ D

Question Number : 30 Question Type : MCQ

A drill is positioned at point P and it has to proceed to point Q. The coordinates of point Q in the incremental system of defining position of a point in CNC part program will be

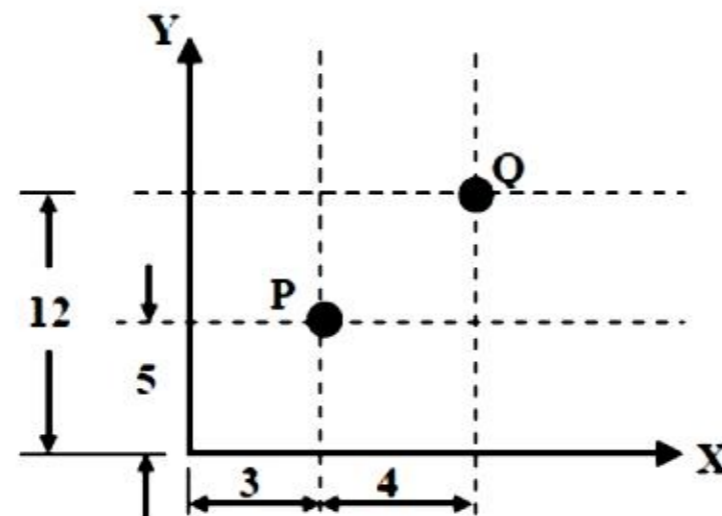

(A) (3, 12)

(B) (5, 7)

(C) (7, 12)

(D) (4, 7)

Options :

- 1. ✘ A
- 2. ✘ B
- 3. ✘ C
- 4. ✔ D

Question Number : 31 Question Type : MCQ

Which two of the following joining processes are autogeneous?

- (i) Diffusion welding
- (ii) Electroslag welding
- (iii) Tungsten inert gas welding
- (iv) Friction welding

(A) (i) and (iv) (B) (ii) and (iii) (C) (ii) and (iv) (D) (i) and (iii)

Options :

- 1. ✓ A
- 2. ✗ B
- 3. ✗ C
- 4. ✗ D

Question Number : 32 Question Type : MCQ

Three parallel pipes connected at the two ends have flow-rates Q_1 , Q_2 and Q_3 respectively, and the corresponding frictional head losses are h_{L1} , h_{L2} and h_{L3} respectively. The correct expressions for total flow rate (Q) and frictional head loss across the two ends (h_L) are

- (A) $Q = Q_1 + Q_2 + Q_3$; $h_L = h_{L1} + h_{L2} + h_{L3}$
- (B) $Q = Q_1 + Q_2 + Q_3$; $h_L = h_{L1} = h_{L2} = h_{L3}$
- (C) $Q = Q_1 = Q_2 = Q_3$; $h_L = h_{L1} + h_{L2} + h_{L3}$
- (D) $Q = Q_1 = Q_2 = Q_3$; $h_L = h_{L1} = h_{L2} = h_{L3}$

Options :

- 1. ✗ A
- 2. ✓ B
- 3. ✗ C
- 4. ✗ D

Question Number : 33 Question Type : MCQ

A rigid container of volume 0.5 m^3 contains 1.0 kg of water at 120°C ($v_f = 0.00106 \text{ m}^3/\text{kg}$, $v_g = 0.8908 \text{ m}^3/\text{kg}$). The state of water is

- (A) compressed liquid
- (B) saturated liquid
- (C) a mixture of saturated liquid and saturated vapor
- (D) superheated vapor

Options :

- 1. ✗ A
- 2. ✗ B
- 3. ✓ C
- 4. ✗ D

Question Number : 34 Question Type : MCQ

Let ϕ be an arbitrary smooth real valued scalar function and \vec{V} be an arbitrary smooth vector valued function in a three-dimensional space. Which one of the following is an identity?

(A) $\text{Curl}(\phi\vec{V}) = \nabla(\phi \text{Div}\vec{V})$

(B) $\text{Div}\vec{V} = 0$

(C) $\text{Div Curl}\vec{V} = 0$

(D) $\text{Div}(\phi\vec{V}) = \phi \text{Div}\vec{V}$

Options :

1. ✘ A

2. ✘ B

3. ✔ C

4. ✘ D

Question Number : 35 Question Type : MCQ

An air-standard Diesel cycle consists of the following processes:

1-2: Air is compressed isentropically.

2-3: Heat is added at constant pressure.

3-4: Air expands isentropically to the original volume.

4-1: Heat is rejected at constant volume.

If γ and T denote the specific heat ratio and temperature, respectively, the efficiency of the cycle is

(A) $1 - \frac{T_4 - T_1}{T_3 - T_2}$

(B) $1 - \frac{T_4 - T_1}{\gamma(T_3 - T_2)}$

(C) $1 - \frac{\gamma(T_4 - T_1)}{T_3 - T_2}$

(D) $1 - \frac{T_4 - T_1}{(\gamma - 1)(T_3 - T_2)}$

Options :

1. ✘ A

2. ✔ B

3. ✘ C

4. ✘ D

Question Number : 36 Question Type : MCQ

The value of moment of inertia of the section shown in the figure about the axis-XX is

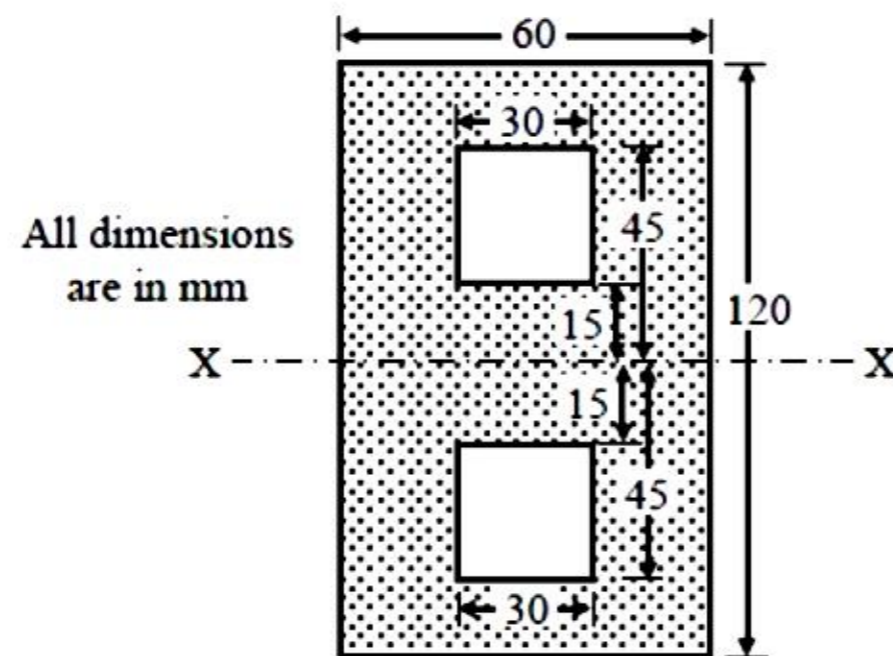

(A) $8.5050 \times 10^6 \text{ mm}^4$
 (C) $7.7625 \times 10^6 \text{ mm}^4$

(B) $6.8850 \times 10^6 \text{ mm}^4$
 (D) $8.5725 \times 10^6 \text{ mm}^4$

Options :

1. ✘ A
2. ✔ B
3. ✘ C
4. ✘ D

Question Number : 37 Question Type : NAT

Figure shows a wheel rotating about O_2 . Two points A and B located along the radius of wheel have speeds of 80 m/s and 140 m/s respectively. The distance between the points A and B is 300 mm. The diameter of the wheel (in mm) is _____

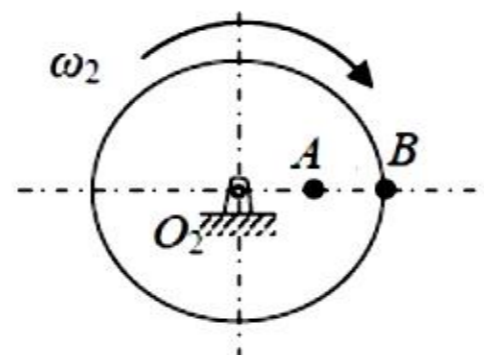

Correct Answer :

1390 to 1410

Question Number : 38 Question Type : MCQ

Figure shows a single degree of freedom system. The system consists of a massless rigid bar OP hinged at O and a mass m at end P. The natural frequency of vibration of the system is

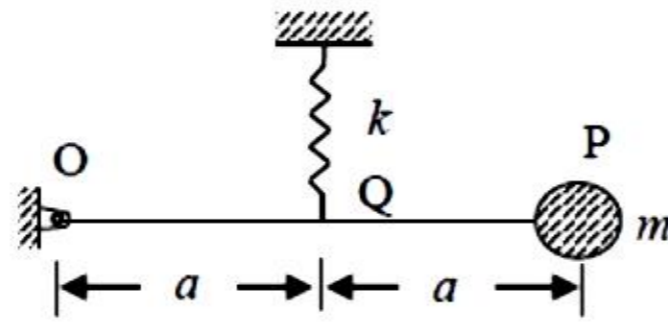

(A) $f_n = \frac{1}{2\pi} \sqrt{\frac{k}{4m}}$

(B) $f_n = \frac{1}{2\pi} \sqrt{\frac{k}{2m}}$

(C) $f_n = \frac{1}{2\pi} \sqrt{\frac{k}{m}}$

(D) $f_n = \frac{1}{2\pi} \sqrt{\frac{2k}{m}}$

Options :

1. ✓ A
2. ✗ B
3. ✗ C
4. ✗ D

Question Number : 39 Question Type : MCQ

The number of degrees of freedom of the linkage shown in the figure is

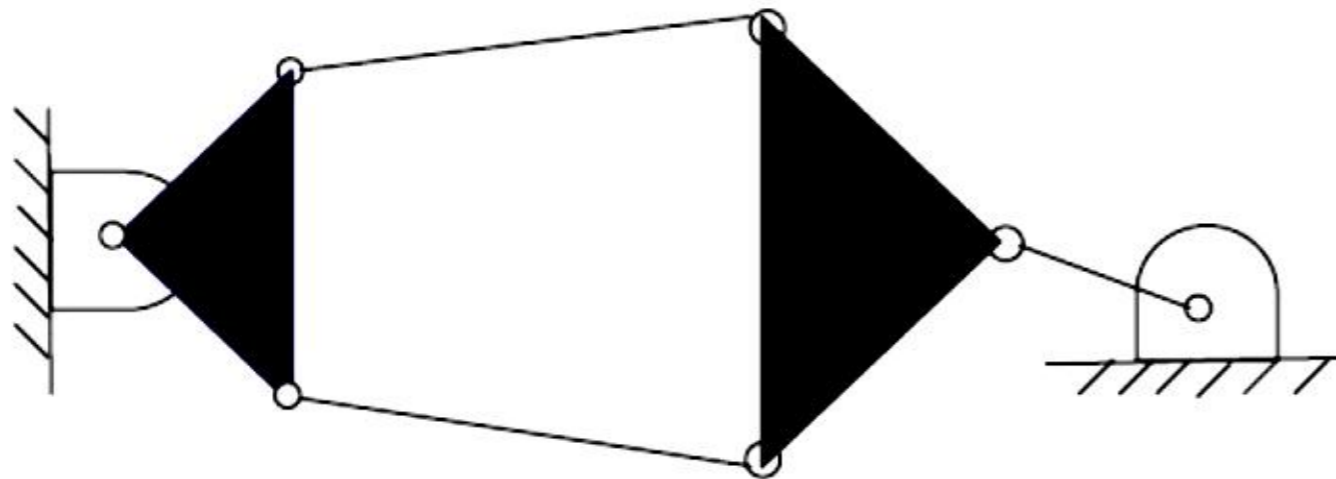

(A) -3

(B) 0

(C) 1

(D) 2

Options :

1. ✗ A
2. ✗ B
3. ✓ C
4. ✗ D

Question Number : 40 Question Type : NAT

For ball bearings, the fatigue life L measured in number of revolutions and the radial load F are related by $FL^{1/3} = K$, where K is a constant. It withstands a radial load of 2 kN for a life of 540 million revolutions. The load (in kN) for a life of one million revolutions is _____

Correct Answer:

15 to 17

Question Number : 41 Question Type : NAT

In a rolling operation using rolls of diameter 500 mm, if a 25 mm thick plate cannot be reduced to less than 20 mm in one pass, the coefficient of friction between the roll and the plate is _____

Correct Answer :

0.10 to 0.15

Question Number : 42 Question Type : NAT

Ratio of solidification time of a cylindrical casting (height = radius) to that of a cubic casting of side two times the height of cylindrical casting is _____

Correct Answer :

0.5 to 0.6

Question Number : 43 Question Type : NAT

The annual requirement of rivets at a ship manufacturing company is 2000 kg. The rivets are supplied in units of 1 kg costing Rs. 25 each. If it costs Rs. 100 to place an order and the annual cost of carrying one unit is 9% of its purchase cost, the cycle length of the order (in days) will be _____

Correct Answer :

76 to 78

Question Number : 44 Question Type : MCQ

Orthogonal turning of a mild steel tube with a tool of rake angle 10° is carried out at a feed of 0.14 mm/rev. If the thickness of the chip produced is 0.28 mm, the values of shear angle and shear strain will be respectively

- (A) $28^\circ 20'$ and 2.19 (B) $22^\circ 20'$ and 3.53 (C) $24^\circ 30'$ and 4.19 (D) $37^\circ 20'$ and 5.19

Options :

1. ✓ A
2. ✗ B
3. ✗ C
4. ✗ D

Question Number : 45 Question Type : MCQ

In a CNC milling operation, the tool has to machine the circular arc from point (20, 20) to (10, 10) at sequence number 5 of the CNC part program. If the center of the arc is at (20, 10) and the machine has incremental mode of defining position coordinates, the correct tool path command is

- (A) N 05 G90 G01 X-10 Y-10 R10
(B) N 05 G91 G03 X-10 Y-10 R10
(C) N 05 G90 G03 X20 Y20 R10
(D) N 05 G91 G02 X20 Y20 R10

Options :

1. ✗ A
2. ✓ B
3. ✗ C
4. ✗ D

Question Number : 46 Question Type : NAT

A Prandtl tube (Pitot-static tube with $C=1$) is used to measure the velocity of water. The differential manometer reading is 10 mm of liquid column with a relative density of 10. Assuming $g = 9.8 \text{ m/s}^2$, the velocity of water (in m/s) is _____

Correct Answer :

1.30 to 1.34

Question Number : 47 Question Type : NAT

Refrigerant vapor enters into the compressor of a standard vapor compression cycle at -10°C ($h = 402 \text{ kJ/kg}$) and leaves the compressor at 50°C ($h = 432 \text{ kJ/kg}$). It leaves the condenser at 30°C ($h = 237 \text{ kJ/kg}$). The COP of the cycle is _____

Correct Answer:

5.5

Question Number : 48 Question Type : NAT

Steam enters a turbine at 30 bar, 300°C ($u = 2750$ kJ/kg, $h = 2993$ kJ/kg) and exits the turbine as saturated liquid at 15 kPa ($u = 225$ kJ/kg, $h = 226$ kJ/kg). Heat loss to the surrounding is 50 kJ/kg of steam flowing through the turbine. Neglecting changes in kinetic energy and potential energy, the work output of the turbine (in kJ/kg of steam) is _____

Correct Answer :

2717

Question Number : 49 Question Type : NAT

Air in a room is at 35°C and 60% relative humidity (RH). The pressure in the room is 0.1 MPa. The saturation pressure of water at 35°C is 5.63 kPa. The humidity ratio of the air (in gram/kg of dry air) is _____

Correct Answer :

21.7 to 21.9

Question Number : 50 Question Type : MCQ

A solid sphere 1 of radius ' r ' is placed inside a hollow, closed hemispherical surface 2 of radius ' $4r$ '. The shape factor $F_{2,1}$ is

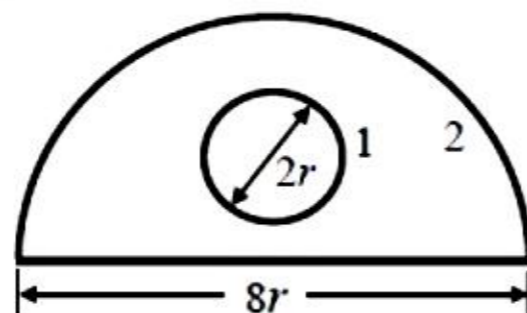

(A) 1/12

(B) 1/2

(C) 2

(D) 12

Options :

1. ✓ A

2. ✗ B

3. ✗ C

4. ✗ D

Question Number : 51 Question Type : NAT

The value of

$\int_C [(3x - 8y^2)dx + (4y - 6xy)dy]$, (where C is the boundary of the region bounded by $x = 0$, $y = 0$ and $x + y = 1$) is _____

Correct Answer :

1.60 to 1.70

Question Number : 52 Question Type : MCQ

For a given matrix $P = \begin{bmatrix} 4 + 3i & -i \\ i & 4 - 3i \end{bmatrix}$, where $i = \sqrt{-1}$, the inverse of matrix P is

- (A) $\frac{1}{24} \begin{bmatrix} 4 - 3i & i \\ -i & 4 + 3i \end{bmatrix}$ (B) $\frac{1}{25} \begin{bmatrix} i & 4 - 3i \\ 4 + 3i & -i \end{bmatrix}$
- (C) $\frac{1}{24} \begin{bmatrix} 4 + 3i & -i \\ i & 4 - 3i \end{bmatrix}$ (D) $\frac{1}{25} \begin{bmatrix} 4 + 3i & -i \\ i & 4 - 3i \end{bmatrix}$

Options :

1. ✓ A
2. ✗ B
3. ✗ C
4. ✗ D

Question Number : 53 Question Type : NAT

Newton-Raphson method is used to find the roots of the equation, $x^3 + 2x^2 + 3x - 1 = 0$. If the initial guess is $x_0 = 1$, then the value of x after 2nd iteration is _____

Correct Answer :

0.29 to 0.31

Question Number : 54 Question Type : MCQ

Laplace transform of the function $f(t)$ is given by $F(s) = L\{f(t)\} = \int_0^{\infty} f(t)e^{-st} dt$.

Laplace transform of the function shown below is given by

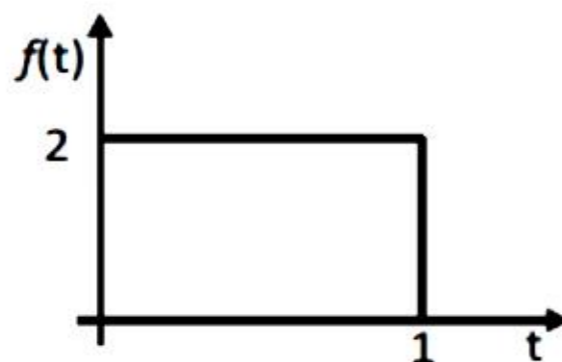

- (A) $\frac{1 - e^{-2s}}{s}$ (B) $\frac{1 - e^{-s}}{2s}$ (C) $\frac{2 - 2e^{-s}}{s}$ (D) $\frac{1 - 2e^{-s}}{s}$

Options :

1. ✗ A

- 2. ✘ B
- 3. ✔ C
- 4. ✘ D

Question Number : 55 Question Type : NAT

A bullet spins as the shot is fired from a gun. For this purpose, two helical slots as shown in the figure are cut in the barrel. Projections A and B on the bullet engage in each of the slots.

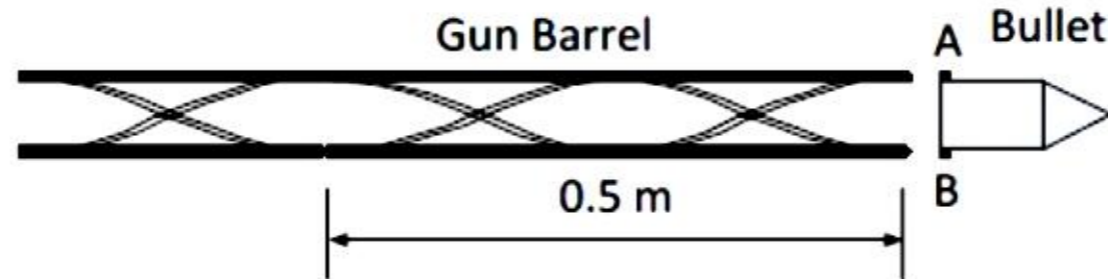

Helical slots are such that one turn of helix is completed over a distance of 0.5 m. If velocity of bullet when it exits the barrel is 20 m/s, its spinning speed in rad/s is _____

Correct Answer:

251 to 252

Question Number : 56 Question Type : NAT

For the overhanging beam shown in figure, the magnitude of maximum bending moment (in kN-m) is _____

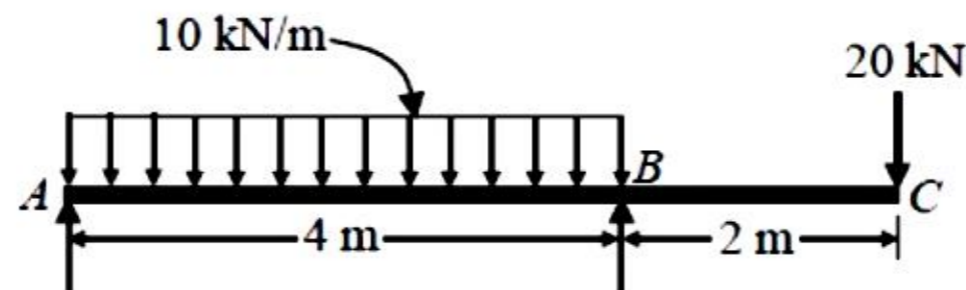

Correct Answer:

40

Question Number : 57 Question Type : NAT

The torque (in N-m) exerted on the crank shaft of a two stroke engine can be described as $T = 10000 + 1000 \sin 2\theta - 1200 \cos 2\theta$, where θ is the crank angle as measured from inner dead center position. Assuming the resisting torque to be constant, the power (in kW) developed by the engine at 100 rpm is _____

Correct Answer:

Question Number : 58 Question Type : NAT

A cantilever bracket is bolted to a column using three M12×1.75 bolts P, Q and R. The value of maximum shear stress developed in the bolt P (in MPa) is _____

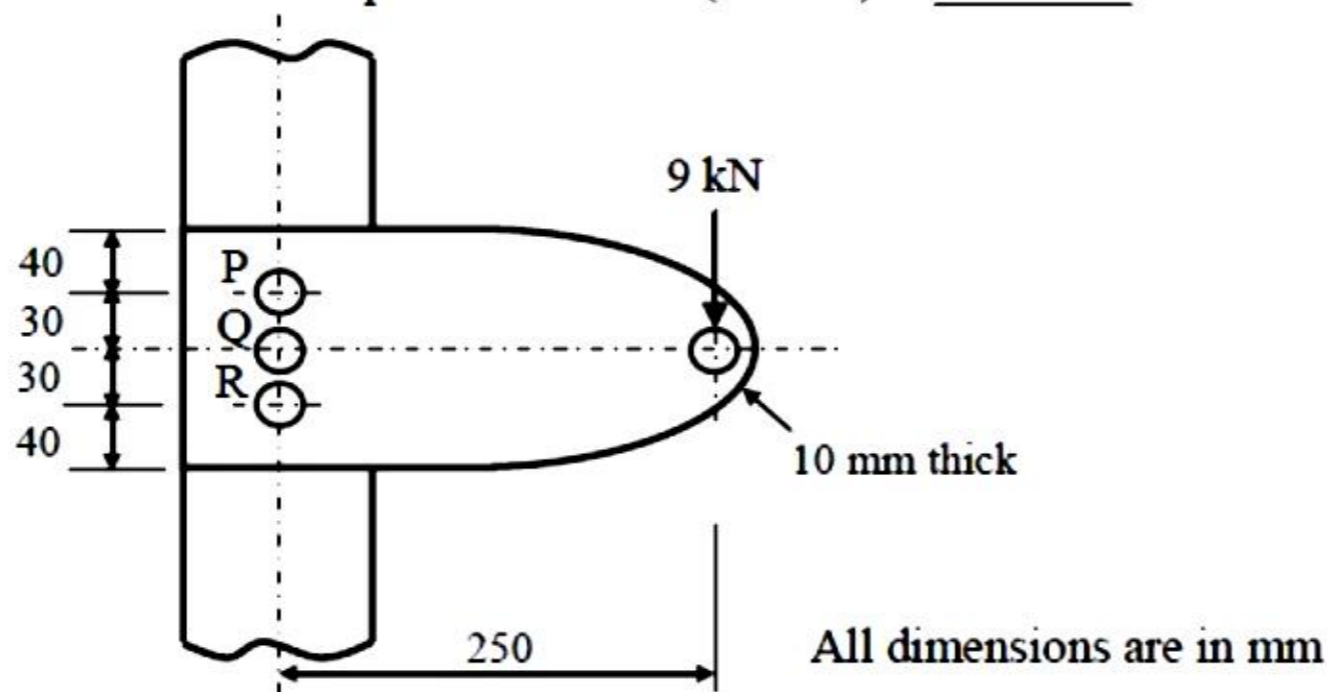

Correct Answer:

332 to 494

Question Number : 59 Question Type : MCQ

A shaft of length 90 mm has a tapered portion of length 55 mm. The diameter of the taper is 80 mm at one end and 65 mm at the other. If the taper is made by tailstock set over method, the taper angle and the set over respectively are

- (A) $15^{\circ}32'$ and 12.16 mm (B) $18^{\circ}32'$ and 15.66 mm
 (C) $11^{\circ}22'$ and 10.26 mm (D) $10^{\circ}32'$ and 14.46 mm

Options :

1. ✓ A
 2. ✗ B
 3. ✗ C
 4. ✗ D

Question Number : 60 Question Type : NAT

The dimensions of a cylindrical side riser (height = diameter) for a 25 cm × 15 cm × 5 cm steel casting are to be determined. For the tabulated shape factor values given below, the diameter of the riser (in cm) is _____

Shape factor	2	4	6	8	10	12
Riser volume/ Casting volume	1.0	0.70	0.55	0.50	0.40	0.35

Correct Answer:

10.5 to 10.7

Question Number : 61 Question Type : MCQ

For the linear programming problem:

$$\text{Maximize } Z = 3X_1 + 2X_2$$

Subject to

$$-2X_1 + 3X_2 \leq 9$$

$$X_1 - 5X_2 \geq -20$$

$$X_1, X_2 \geq 0$$

The above problem has

(A) unbounded solution

(B) infeasible solution

(C) alternative optimum solution

(D) degenerate solution

Options :

1. ✓ A

2. ✗ B

3. ✗ C

4. ✗ D

Question Number : 62 Question Type : MCQ

Which of the following statements are **TRUE**, when the cavitation parameter $\sigma = 0$?

(i) the local pressure is reduced to vapor pressure

(ii) cavitation starts

(iii) boiling of liquid starts

(iv) cavitation stops

(A) (i), (ii) and (iv)

(B) only (ii) and (iii)

(C) only (i) and (iii)

(D) (i), (ii) and (iii)

Options :

1. ✗ A

2. ✗ B

3. ✗ C

4. ✓ D

Question Number : 63 Question Type : NAT

One side of a wall is maintained at 400 K and the other at 300 K. The rate of heat transfer through the wall is 1000 W and the surrounding temperature is 25°C. Assuming no generation of heat within the wall, the irreversibility (in W) due to heat transfer through the wall is _____

Correct Answer:

247 to 249

Question Number : 64 Question Type : MCQ

A brick wall ($k = 0.9 \frac{W}{m.K}$) of thickness 0.18 m separates the warm air in a room from the cold ambient air. On a particular winter day, the outside air temperature is -5°C and the room needs to be maintained at 27°C . The heat transfer coefficient associated with outside air is $20 \frac{W}{m^2.K}$. Neglecting the convective resistance of the air inside the room, the heat loss, in ($\frac{W}{m^2}$), is

- (A) 88 (B) 110 (C) 128 (D) 160

Options :

1. ✘ A
2. ✘ B
3. ✔ C
4. ✘ D

Question Number : 65 Question Type : NAT

A mixture of ideal gases has the following composition by mass:

N_2	O_2	CO_2
60%	30%	10%

If the universal gas constant is 8314 J/kmol-K , the characteristic gas constant of the mixture (in J/kg-K) is _____

Correct Answer :

274 to 276