

Question Paper Name: Electronics and Communication Engineering 11th May 2017 Shift I
Subject Name: Electronics and Communication Engineering
Duration: 120

Electronics and Communication Engineering

Display Number Panel: Yes
Group All Questions: No

Question Number : 1 Question Id : 871112361 Display Question Number : Yes Single Line Question Option : No Option Orientation : Vertical

If $\lambda = a + ib$ is an eigenvalue of a Hermitian matrix, then

Options :

1. $b = 0$
2. $a = 0$
3. $|a + ib| = 1$
4. $ab \neq 0$

Question Number : 2 Question Id : 871112362 Display Question Number : Yes Single Line Question Option : No Option Orientation : Vertical

The length of one loop of the curve $6y^2 = x(x - 2)^2$ is

Options :

1. $\frac{8}{\sqrt{3}}$
2. $\frac{4}{\sqrt{3}}$
3. $\frac{\sqrt{3}}{8}$
4. $\frac{\sqrt{3}}{4}$

Question Number : 3 Question Id : 871112363 Display Question Number : Yes Single Line Question Option : No Option Orientation : Vertical

The maximum value of xyz^2 subject to $x^2 + y^2 + z^2 = 1$ is

Options :

2. $\frac{1}{4}$
3. $\frac{1}{2}$
4. $\frac{1}{16}$

Question Number : 4 Question Id : 871112364 Display Question Number : Yes Single Line Question Option : No Option Orientation : Vertical

The solution of differential equation $dx - (x + y + 1)dy = 0$ is

Options :

1. $(x + y + 2)e^y = c$
2. $(x - y - 2)e^y = c$
3. $(x + y + 2)e^{-y} = c$
4. $(x - y + 2)e^y = c$

Question Number : 5 Question Id : 871112365 Display Question Number : Yes Single Line Question Option : No Option Orientation : Vertical

If the rate of disintegration of uranium is proportional to its mass with λ as the constant of proportionality then the half-life of uranium is

Options :

1. $\frac{1}{\lambda} \ln 2$
2. $\lambda \ln 2$
3. $\frac{\lambda}{\ln 2}$
4. $\frac{1}{\lambda \ln 2}$

Question Number : 6 Question Id : 871112366 Display Question Number : Yes Single Line Question Option : No Option Orientation : Vertical

An example of a nowhere analytic function is

Options :

1. $e^x(\cos y + i \sin y)$
2. $(x - y)^2 + 2i(x + y)$

Question Number : 7 Question Id : 871112367 Display Question Number : Yes Single Line Question Option : No Option Orientation : Vertical

In a family of four children, the probability that at least one child is a girl, is

Options :

1. $\frac{15}{16}$
2. $\frac{3}{4}$
3. $\frac{1}{4}$
4. $\frac{1}{16}$

Question Number : 8 Question Id : 871112368 Display Question Number : Yes Single Line Question Option : No Option Orientation : Vertical

In a college 60% are girls and 40% are boys; 25% of boys and 10% of girls study mathematics. If a student is chosen at random then the probability that he/she studies mathematics is

Options :

1. $\frac{4}{25}$
2. $\frac{3}{8}$
3. $\frac{5}{8}$
4. $\frac{21}{25}$

Question Number : 9 Question Id : 871112369 Display Question Number : Yes Single Line Question Option : No Option Orientation : Vertical

From the table given below

x	0	1	2	3	4
$f(x)$	1	1.5	3	5.5	9

The value of $\int_0^4 f(x)dx$ by Simpson's rule, is

Options :

1. 12.00

4. 15.00

Question Number : 10 Question Id : 871112370 Display Question Number : Yes Single Line Question Option : No Option Orientation : Vertical

The value of $y(0.2)$, by Euler's method, if $y(0) = 1, h = 0.2, f(x_0, y_0) = 1$, is

Options :

1. 1.02
2. 0.98
3. 1.2
4. 0.99

Question Number : 11 Question Id : 871112371 Display Question Number : Yes Single Line Question Option : No Option Orientation : Vertical

The magnitude of the frequency response of a second order closed loop system with transfer function $\frac{C(S)}{R(S)} = \frac{8}{S^2+S+4}$ is shown below.

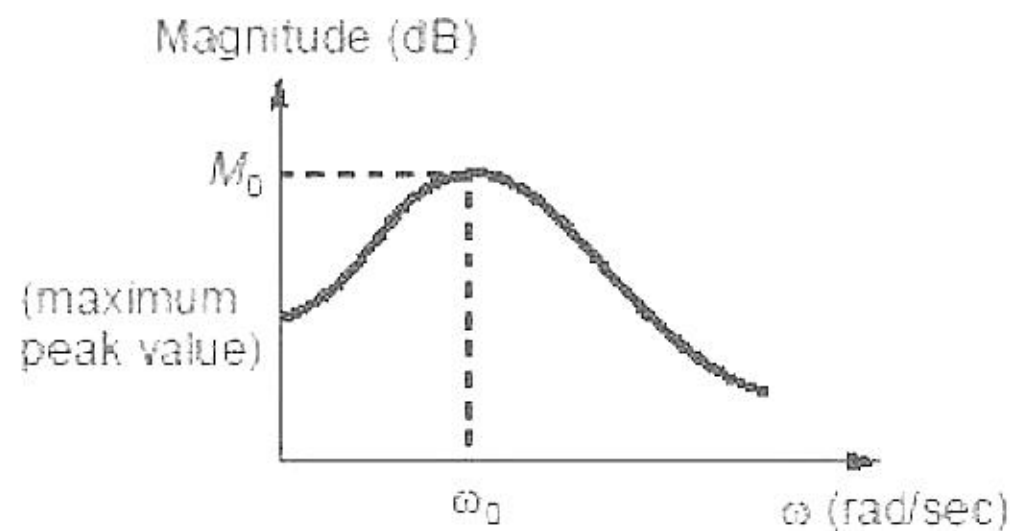

The resonant frequency ω_0 and the resonant peak M_0 are

Options :

1. $\omega_0 = 0.66$ rad/sec, $M_0 = 6.30$ dB
2. $\omega_0 = 0.66$ rad/sec, $M_0 = 12.30$ dB
3. $\omega_0 = 1.87$ rad/sec, $M_0 = 12.30$ dB
4. $\omega_0 = 1.87$ rad/sec, $M_0 = 6.30$ dB

Question Number : 12 Question Id : 871112372 Display Question Number : Yes Single Line Question Option : No Option Orientation : Vertical

A source of angular frequency 1 rad/sec has a source impedance consisting of 1 Ω resistance in series with 1 H inductance. The load that will obtain the maximum power transfer is

2. *
3. 1Ω resistance in series with a 1 F capacitor.
4. 1Ω resistance in parallel with a 1 F capacitor.

Question Number : 13 Question Id : 871112373 Display Question Number : Yes Single Line Question Option : No Option Orientation : Vertical

Which of the following cannot be connected in series unless they are identical?

Options :

1. Voltage sources
2. Current sources
3. Voltage sources and Current sources
4. Resistances

Question Number : 14 Question Id : 871112374 Display Question Number : Yes Single Line Question Option : No Option Orientation : Vertical

A series RLC circuit has $R = 80 \Omega$, $L = 240 \text{ mH}$ and $C = 5 \text{ mF}$. If the input voltage is $v(t) = 10 \cos(2t) \text{ V}$ then current flowing through the circuit is

Options :

1. $29.61 \cos(2t - 51.2^\circ) \text{ mA}$
2. $29.61 \cos(2t + 51.2^\circ) \text{ mA}$
3. $78.32 \cos(2t - 51.2^\circ) \text{ mA}$
4. $78.32 \cos(2t + 51.2^\circ) \text{ mA}$

Question Number : 15 Question Id : 871112375 Display Question Number : Yes Single Line Question Option : No Option Orientation : Vertical

Reactance curve is a graph drawn between _____ and _____ .

Options :

1. Reactance, Frequency
2. Reactance, Phase
3. Frequency, Amplitude
4. Phase, Time period

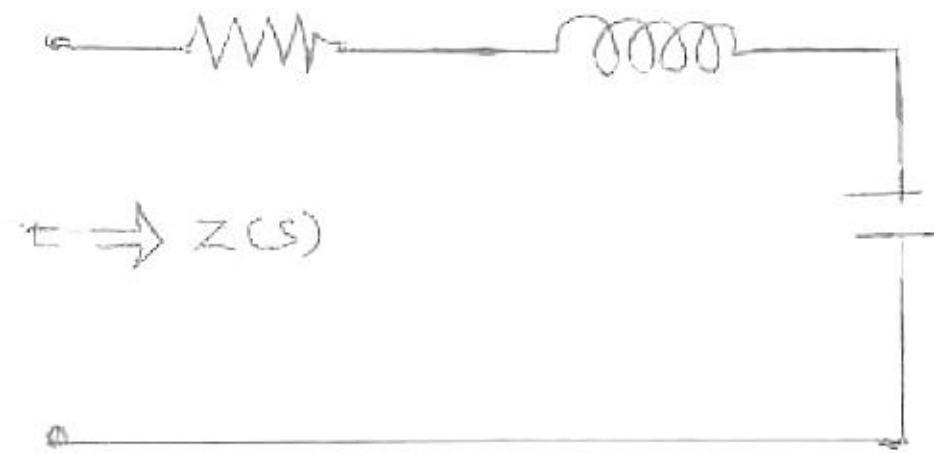

Options :

1. poles at $s = 0, s = \infty$
2. poles at $s = 0$ and zero at $s = \infty$
3. no poles at $s = 0$
4. no poles at $s = \infty$

Question Number : 17 Question Id : 871112377 Display Question Number : Yes Single Line Question Option : No Option Orientation : Vertical

A series RLC circuit has resonance frequency of 1 kHz and a quality factor $Q = 100$. If each of R, L and C is doubled from its original value, the new Q of the circuit is

Options :

1. 25
2. 50
3. 100
4. 200

Question Number : 18 Question Id : 871112378 Display Question Number : Yes Single Line Question Option : No Option Orientation : Vertical

Calculate the current (I) in the following network.

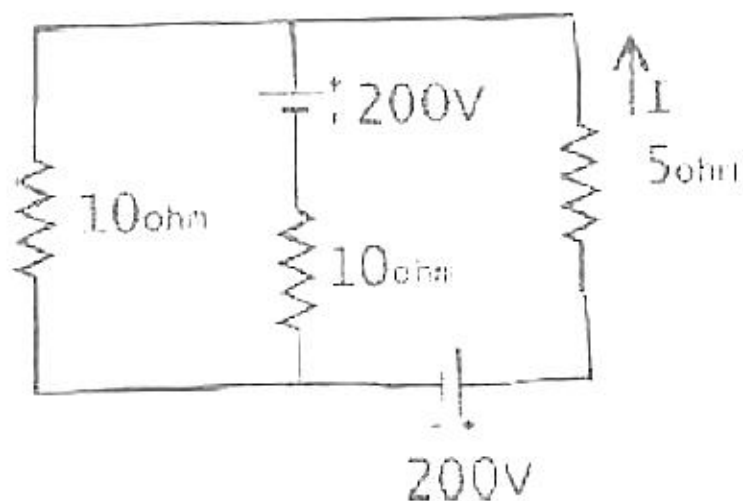

Options :

3. 5A
4. -5A

Question Number : 19 Question Id : 871112379 Display Question Number : Yes Single Line Question Option : No Option Orientation : Vertical

The switch S in the circuit shown has been closed for a long time. It is opened at time $t = 0$ and remains open after that. Assume that the diode has zero reverse current and zero forward voltage drop. The steady state magnitude of the capacitor voltage V_c (in volts) is

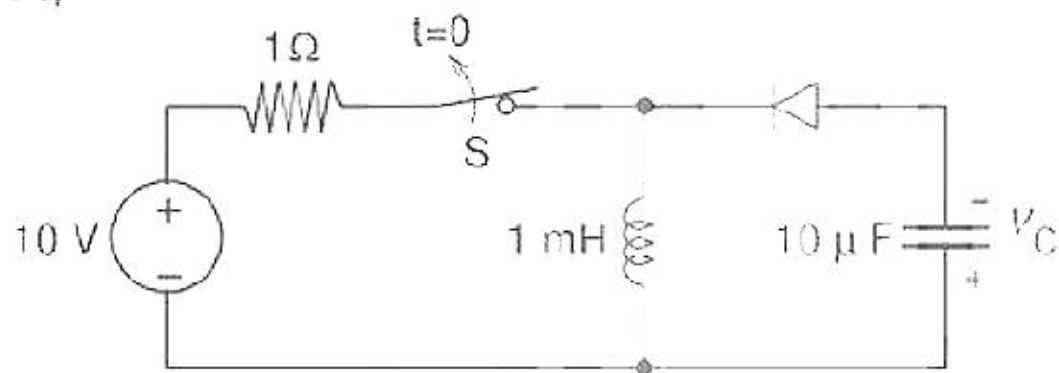

Options :

1. 100
2. 105
3. 110
4. 115

Question Number : 20 Question Id : 871112380 Display Question Number : Yes Single Line Question Option : No Option Orientation : Vertical

A two port network is defined by the relations: $I_1 = 2V_1 + V_2$ and $I_2 = 2V_1 + 3V_2$ then Z_{12} is

Options :

1. 2Ω
2. 1Ω
3. 0.5Ω
4. 0.25Ω

Question Number : 21 Question Id : 871112381 Display Question Number : Yes Single Line Question Option : No Option Orientation : Vertical

Two coupled coils of $L_1 = 0.8 \text{ H}$ and $L_2 = 0.2 \text{ H}$ are having a coupling coefficient $K = 0.9$. The mutual inductance M is

Options :

1. 0.144 H

3.

0.43 H

4.

Question Number : 22 Question Id : 871112382 Display Question Number : Yes Single Line Question Option : No Option Orientation : Vertical

The Y-Parameters of a two port network is $Y = \begin{bmatrix} 0 & \frac{-1}{2} \\ \frac{1}{2} & \frac{1}{2} \end{bmatrix} \Omega$ then the Network is

Options :

1. Asymmetrical, Reciprocal and Passive
2. Asymmetrical, Non-Reciprocal and Active
3. Symmetrical, Non-Reciprocal and Active
4. Symmetrical, Reciprocal and Passive

Question Number : 23 Question Id : 871112383 Display Question Number : Yes Single Line Question Option : No Option Orientation : Vertical

Tunnel diode is used as

Options :

1. High speed switch
2. Clipper
3. Low gain amplifier
4. Low frequency oscillator

Question Number : 24 Question Id : 871112384 Display Question Number : Yes Single Line Question Option : No Option Orientation : Vertical

At 300 K, a Si diode has a saturation current of 10 nA. If the current through diode is 5 mA, then voltage across the diode is

Options :

1. 0.28 V
2. 0.96 V
3. 0.68 V
4. 0.79 V

Options :

1. direction of electron flow
2. direction of holes flow
3. direction of the flow of conventional current
4. collector current flow

Question Number : 26 Question Id : 871112386 Display Question Number : Yes Single Line Question Option : No Option Orientation : Vertical

A BJT can ideally be used as

Options :

1. Current Controlled Current Source
2. Voltage Controlled Voltage Source
3. Current Controlled Voltage Source
4. Voltage Controlled Current Source

Question Number : 27 Question Id : 871112387 Display Question Number : Yes Single Line Question Option : No Option Orientation : Vertical

A MOSFET in saturation has a drain current of 1mA for $V_{ds} = 0.5$ V. If the channel length modulation coefficient is 0.05 V^{-1} , the output resistance(in k Ω)of the MOSFET is

Options :

1. 10
2. 20
3. 30
4. 40

Question Number : 28 Question Id : 871112388 Display Question Number : Yes Single Line Question Option : No Option Orientation : Vertical

An increase in the base recombination of a BJT will increase

Options :

1. The common emitter dc current gain β
2. The break down voltage BV_{CE0}
3. The unity gain cut off frequency f_T

Orientation : Vertical

The constant current area of a FET lies in between

Options :

1. Cutoff and saturation
2. Cutoff and pinchoff
3. Pinchoff and breakdown
4. 0 and I_{DSS}

Question Number : 30 Question Id : 871112390 Display Question Number : Yes Single Line Question Option : No Option Orientation : Vertical

If $\alpha = 0.98$, $I_{CO} = 6 \mu A$ and $I_B = 100 \mu A$ for a transistor then value of I_C will be

Options :

1. 6.2 mA
2. 5.4 mA
3. 5.2 mA
4. 4.6 mA

Question Number : 31 Question Id : 871112391 Display Question Number : Yes Single Line Question Option : No Option Orientation : Vertical

MOSFET is a

Options :

1. Three terminal device
2. Four terminal device
3. Two terminal device
4. Five terminal device

Question Number : 32 Question Id : 871112392 Display Question Number : Yes Single Line Question Option : No Option Orientation : Vertical

Under low level injection assumption, the injected minority carrier current for an extrinsic semiconductor is essentially the

Options :

1. Diffusion current
2. Drift current

Question Number : 33 Question Id : 871112393 Display Question Number : Yes Single Line Question Option : No Option Orientation : Vertical

An LED is connected to a supply voltage of 15 V through a 2.2 k Ω resistor. The voltage across LED is 2 V. The current through the LED is

Options :

1. 6.8 mA
2. 13 mA
3. 5.91 mA
4. 3.9 mA

Question Number : 34 Question Id : 871112394 Display Question Number : Yes Single Line Question Option : No Option Orientation : Vertical

For MOSFET to work as an amplifier, it should be biased in

Options :

1. Saturation region
2. Linear region
3. Cutoff region
4. Unsaturation region

Question Number : 35 Question Id : 871112395 Display Question Number : Yes Single Line Question Option : No Option Orientation : Vertical

The Ebers-Moll model of a BJT is valid

Options :

1. only in active mode
2. only in active and saturation modes
3. only in active and cut-off modes
4. in active, saturation and cut-off modes

Question Number : 36 Question Id : 871112396 Display Question Number : Yes Single Line Question Option : No Option Orientation : Vertical

Which of the following is a characteristic of positive photoresister?

Options :

1. Unexposed areas are removed during development

4. Finer resolution not achieved

Question Number : 37 Question Id : 871112397 Display Question Number : Yes Single Line Question Option : No Option Orientation : Vertical

The configuration of a cascade amplifier is

Options :

1. CE-CE
2. CE-CB
3. CC-CB
4. CC-CC

Question Number : 38 Question Id : 871112398 Display Question Number : Yes Single Line Question Option : No Option Orientation : Vertical

For a BJT, the common-base current gain $\alpha=0.98$ and the collector base junction reverse bias saturation current $I_{CO} = 0.6 \mu\text{A}$. This BJT is connected in the common emitter mode and operated in the active region with a base drive current $I_B = 20 \mu\text{A}$. The collector current I_c for this mode of operation is

Options :

1. 0.98 mA
2. 0.99 mA
3. 1.0 mA
4. 1.01 mA

Question Number : 39 Question Id : 871112399 Display Question Number : Yes Single Line Question Option : No Option Orientation : Vertical

An instrumentation amplifier has a high

Options :

1. output impedance
2. power gain
3. CMRR
4. supply voltage

Question Number : 40 Question Id : 871112400 Display Question Number : Yes Single Line Question Option : No Option Orientation : Vertical

1. reduces gain
2. increases frequency and phase distortions
3. reduces bandwidth
4. increases noise

Question Number : 41 Question Id : 871112401 Display Question Number : Yes Single Line Question Option : No Option Orientation : Vertical

The action of a JFET in its equivalent circuit can best be represented as a

Options :

1. Current controlled current source
2. Current controlled voltage source
3. Voltage controlled voltage source
4. Voltage controlled current source

Question Number : 42 Question Id : 871112402 Display Question Number : Yes Single Line Question Option : No Option Orientation : Vertical

An NPN transistor has a beta cut-off frequency f_{β} of 1 MHz and Common Emitter short circuit low frequency current gain β_0 of 200 at unity gain frequency f_T and the alpha cut-off frequency f_{α} respectively are

Options :

1. 200 MHz, 201 MHz
2. 200 MHz, 199 MHz
3. 199 MHz, 200 MHz
4. 201 MHz, 200 MHz

Question Number : 43 Question Id : 871112403 Display Question Number : Yes Single Line Question Option : No Option Orientation : Vertical

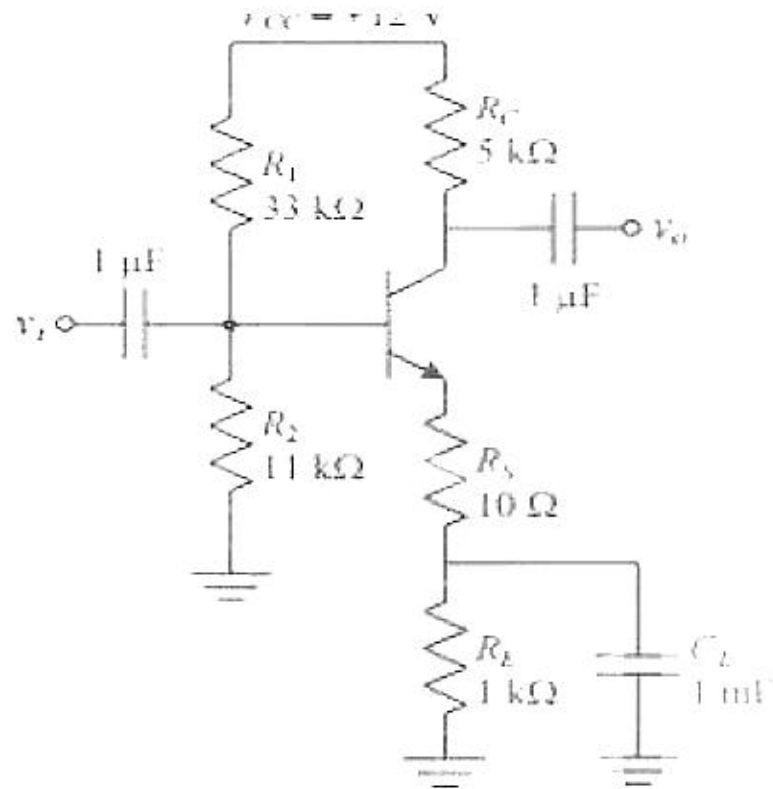

Options :

1. -240 to -230
2. -230 to -220
3. -220 to -210
4. -210 to -200

Question Number : 44 Question Id : 871112404 Display Question Number : Yes Single Line Question Option : No Option Orientation : Vertical

Which of the following configurations has inherent bias stability?

Options :

1. Common Emitter Amplifier
2. Common Base Amplifier
3. Common Source Amplifier
4. Common Emitter with Emitter Degeneration

Question Number : 45 Question Id : 871112405 Display Question Number : Yes Single Line Question Option : No Option Orientation : Vertical

A transistor has $h_{fe} = 160$ and at frequency 50 MHz the magnitude of short circuit current gain is 8. The 3 dB bandwidth of the transistor is

Options :

1. 1.5 MHz
2. 2.5 MHz
3. 3.5 MHz

Question Number : 46 Question Id : 871112406 Display Question Number : Yes Single Line Question Option : No Option Orientation : Vertical

An amplifier has an open-loop gain of 100, an input impedance of 1 k Ω and an output impedance of 100 Ω . A feedback network with a feedback factor of 0.99 is connected to the amplifier in a voltage series feedback mode. The new input and output impedance respectively are

Options :

1. 10 Ω and 1 Ω
2. 10 Ω and 10 Ω
3. 100 k Ω and 1 Ω
4. 100 k Ω and 1 k Ω

Question Number : 47 Question Id : 871112407 Display Question Number : Yes Single Line Question Option : No Option Orientation : Vertical

If a feedback resistor R is connected between positive terminal and output of a non-inverting op-amp having a gain of 2, then the input resistance with respect to ground is

Options :

1. R
2. R/2
3. -R/2
4. -R

Question Number : 48 Question Id : 871112408 Display Question Number : Yes Single Line Question Option : No Option Orientation : Vertical

The final stage of a multistage amplifier uses

Options :

1. RC coupling
2. Transformer coupling
3. Direct coupling
4. Impedance coupling

Question Number : 49 Question Id : 871112409 Display Question Number : Yes Single Line Question Option : No Option Orientation : Vertical

The voltage gain of an amplifier in an oscillator is 50. The attenuation of the feedback circuit must be

3. 1
4. 10

Question Number : 50 Question Id : 871112410 Display Question Number : Yes Single Line Question Option : No Option Orientation : Vertical

CMRR of an op-amp is given as 80db and A_d is 20000. Value of A_{cm} will be

Options :

1. 4
2. 8
3. 2
4. 1

Question Number : 51 Question Id : 871112411 Display Question Number : Yes Single Line Question Option : No Option Orientation : Vertical

The K-map for a Boolean function is shown in the following figure. The number of essential prime implicants for this function are

		AB			
		00	01	11	10
CD	00	1	1	0	1
	01	0	0	0	1
	11	1	0	0	0
	10	1	0	0	1

Options :

1. 4
2. 5
3. 6
4. 8

Question Number : 52 Question Id : 871112412 Display Question Number : Yes Single Line Question Option : No Option Orientation : Vertical

The number of comparators in a 4-bit flash A/D converter is

Options :

1. 4
2. 5
3. 15

Orientation : Vertical

Consider the following logic families:

- A) MOS
- B) DTL
- C) RTL
- D) ECL

The sequence of these logic families in the order of their increasing noise margin is

Options :

- 1. C, D, A, B
- 2. C, D, B, A
- 3. D, C, A, B
- 4. D, C, B, A

Question Number : 54 Question Id : 871112414 Display Question Number : Yes Single Line Question Option : No Option Orientation : Vertical

The Boolean function $Y = AB + CD$ is to be realized using only 2-input gates. The minimum number of gates required is

Options :

- 1. 2
- 2. 3
- 3. 4
- 4. 5

Question Number : 55 Question Id : 871112415 Display Question Number : Yes Single Line Question Option : No Option Orientation : Vertical

Commercially available ECL gates use two ground lines and one negative supply in order to

Options :

- 1. Reduce power dissipation
- 2. Increase fan-out
- 3. Reduce loading effect
- 4. Eliminate the effect of power line glitches on the biasing circuit

Question Number : 56 Question Id : 871112416 Display Question Number : Yes Single Line Question Option : No Option Orientation : Vertical

Options :

1. $10 \mu\text{s}$
2. $20 \mu\text{s}$
3. $40 \mu\text{s}$
4. $50 \mu\text{s}$

Question Number : 57 Question Id : 871112417 Display Question Number : Yes Single Line Question Option : No Option Orientation : Vertical

Consider the following circuits (Assume all gates to have a finite propagation delay):

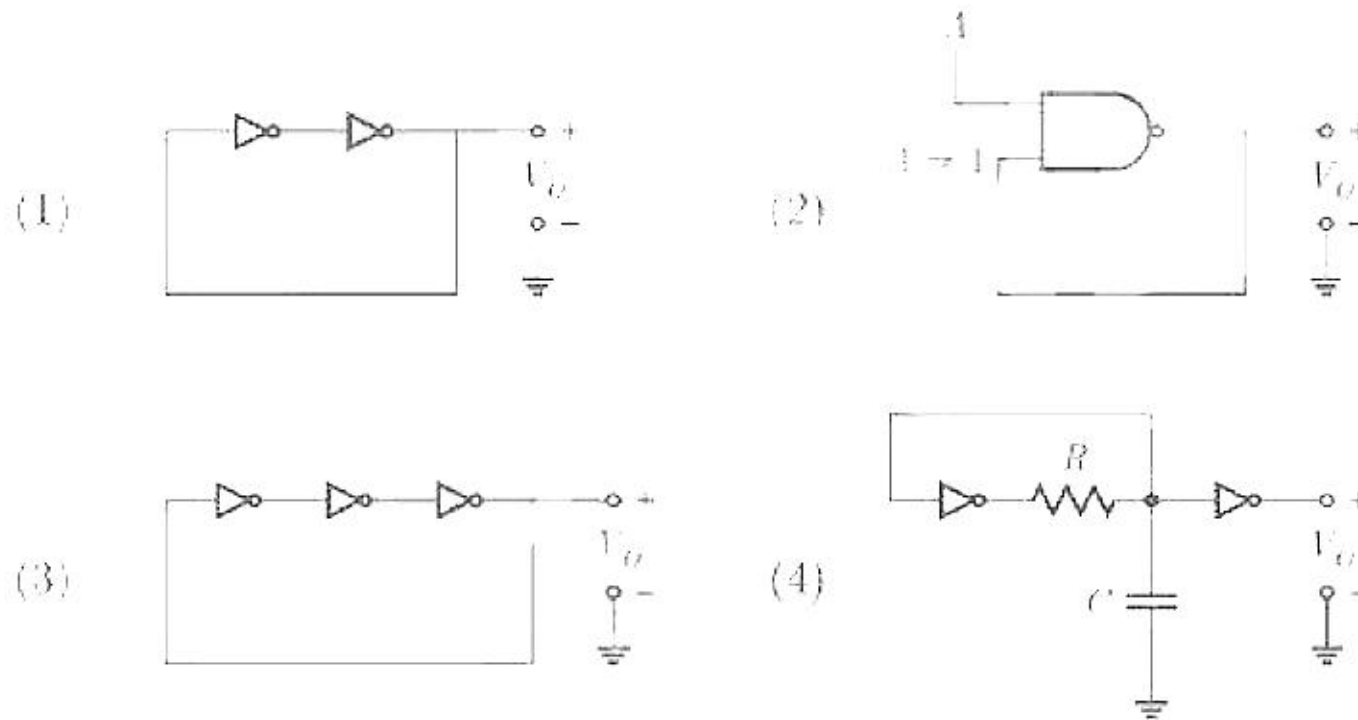

Which of these circuits generate a periodic square wave output?

Options :

1. 1 and 2 only
2. 3 and 4 only
3. 2, 3 and 4 only
4. 1, 2, 3 and 4

Question Number : 58 Question Id : 871112418 Display Question Number : Yes Single Line Question Option : No Option Orientation : Vertical

In an 8085 microprocessor, the registers which store the result of an addition and the carry bit are, respectively

Options :

1. B and F
2. A and F

4. 16.095 ms

Question Number : 62 Question Id : 871112422 Display Question Number : Yes Single Line Question Option : No Option Orientation : Vertical

The 2's complement representation of -17 is

Options :

1. 01110
2. 01111
3. 11110
4. 10001

Question Number : 63 Question Id : 871112423 Display Question Number : Yes Single Line Question Option : No Option Orientation : Vertical

A 4-bit modulo-16 ripple counter uses JK-flip-flops. If the propagation delay of each flip flop is 50 ns, the maximum clock frequency that can be used is equal to

Options :

1. 20 MHz
2. 10 MHz
3. 5 MHz
4. 4 MHz

Question Number : 64 Question Id : 871112424 Display Question Number : Yes Single Line Question Option : No Option Orientation : Vertical

A digital system is required to amplify a binary-encoded audio signal. The user should be able to control the gain of the amplifier from a minimum to a maximum in 100 increments. The minimum number of bits required to encode, in straight binary is

Options :

1. 8
2. 6
3. 5
4. 7

Question Number : 65 Question Id : 871112425 Display Question Number : Yes Single Line Question Option : No Option Orientation : Vertical

The most commonly used amplifier in sample and hold circuit is

Options :

3. An inverting amplifier with a gain of 10
4. An inverting amplifier with a gain of 100

Question Number : 66 Question Id : 871112426 Display Question Number : Yes Single Line Question Option : No Option Orientation : Vertical

Programmable ICs with AND-OR-NOT gates and fuses for AND and OR gates are designated as

Options :

1. PAL
2. PLA
3. ASIC
4. PROM

Question Number : 67 Question Id : 871112427 Display Question Number : Yes Single Line Question Option : No Option Orientation : Vertical

The area under the curve $\int_{-\infty}^{\infty} \delta(t) dt$ is

Options :

1. Infinite
2. Unity
3. Zero
4. Undefined

Question Number : 68 Question Id : 871112428 Display Question Number : Yes Single Line Question Option : No Option Orientation : Vertical

Convolution is used to find

Options :

1. the impulse response of an LTI system
2. the frequency response of the system
3. the time response of an LTI system
4. the phase response of the system

Question Number : 69 Question Id : 871112429 Display Question Number : Yes Single Line Question Option : No Option Orientation : Vertical

Options :

1. Fourier series
2. Discrete Cosine transform
3. Discrete Fourier transform
4. Hilbert transform

Question Number : 70 Question Id : 871112430 Display Question Number : Yes Single Line Question Option : No Option Orientation : Vertical

Fourier transform of a DC signal with unity strength is

Options :

1. Zero
2. 1
3. $2\pi\delta(\omega)$
4. $2\delta(\omega)$

Question Number : 71 Question Id : 871112431 Display Question Number : Yes Single Line Question Option : No Option Orientation : Vertical

The relationship between Laplace transform and frequency response is

Options :

1. Laplace transform and frequency response are unrelated
2. Frequency response is a special case of Laplace transform that is restricted to the imaginary axis of the s-plane
3. Frequency response is the logarithm of Laplace transform
4. Frequency response is the integral of Laplace transform

Question Number : 72 Question Id : 871112432 Display Question Number : Yes Single Line Question Option : No Option Orientation : Vertical

The result of the convolution $x(-t) * \delta(-t - t_0)$ is

Options :

1. $x(t + t_0)$
2. $x(t - t_0)$

Question Number : 73 Question Id : 871112433 Display Question Number : Yes Single Line Question Option : No Option Orientation : Vertical

The Discrete Fourier Transform (DFT) of the 4-point sequence is

$$x[n] = \{x[0], x[1], x[2], x[3]\} = \{3, 2, 3, 4\} \text{ is}$$

$$X[k] = \{X[0], X[1], X[2], X[3]\} = \{12, 2j, 0, -2j\}.$$

If $X_1[k]$ is the DFT of the 12-point sequence $x_1[n] = \{3, 0, 0, 2, 0, 0, 3, 0, 0, 4, 0, 0\}$, the value of $|X_1[8] / X_1[11]|$ is

Options :

1. 6
2. 12
3. 18
4. 24

Question Number : 74 Question Id : 871112434 Display Question Number : Yes Single Line Question Option : No Option Orientation : Vertical

A system is described by the following differential equation, where $u(t)$ is the input to the system and $y(t)$ is the output of the system.

$$y'(t) + 5y(t) = u(t)$$

When $y(0) = 1$ and $u(t)$ is a unit step function, $y(t)$ is

Options :

1. $0.2 - 0.8e^{-5t}$
2. $0.2 - 0.2e^{-5t}$
3. $0.8 - 0.2e^{-5t}$
4. $0.8 - 0.8e^{-5t}$

Question Number : 75 Question Id : 871112435 Display Question Number : Yes Single Line Question Option : No Option Orientation : Vertical

Which of the following statements is true?

- (A) In a system, if the input is bounded then the output is always bounded
- (B) An LTI system is stable only if the integral of the impulse is finite
- (C) An LTI system is always stable
- (D) In a system, even if the input is unbounded the output can be bounded

Options :

1. A only

4. B and D only

Question Number : 76 Question Id : 871112436 Display Question Number : Yes Single Line Question Option : No Option Orientation : Vertical

If $X(Z)$ is z-transform of $x[n]$, then z-transform of $\{a^{-n}x[n]\}$ will be

Options :

1. $X(az)$
2. $X(z/a)$
3. $X(a/z)$
4. $X(1/az)$

Question Number : 77 Question Id : 871112437 Display Question Number : Yes Single Line Question Option : No Option Orientation : Vertical

The Fourier transform of auto-correlation function is equal to

Options :

1. Energy Spectral Density
2. Power Spectral Density
3. Energy Spectral Density and Power Spectral Density
4. Current Spectral Density

Question Number : 78 Question Id : 871112438 Display Question Number : Yes Single Line Question Option : No Option Orientation : Vertical

A system with an input $x(t)$ and an output $y(t)$ is described by the relation: $y(t) = tx(t)$. This system is

Options :

1. Linear and time-invariant
2. Linear and time varying
3. Non-linear and time in-variant
4. Non-linear and time-varying

Question Number : 79 Question Id : 871112439 Display Question Number : Yes Single Line Question Option : No Option Orientation : Vertical

1. E
2. E/2
3. 2E
4. 4E

Question Number : 80 Question Id : 871112440 Display Question Number : Yes Single Line Question Option : No Option Orientation : Vertical

The Laplace transform of $\frac{\sin \pi t}{\pi t} u(t)$ is

Options :

1. $\frac{2\pi}{(s^2 + \pi^2)^2}$
2. $\frac{1}{\pi} \cot^{-1} \frac{s}{\pi}$
3. $\frac{1}{\pi} \tan^{-1} \frac{s}{\pi}$
4. $2\pi(s^2 + \pi^2)$

Question Number : 81 Question Id : 871112441 Display Question Number : Yes Single Line Question Option : No Option Orientation : Vertical

The gain margin of a system is 0 dB. It represents a

Options :

1. Stable system
2. Unstable system
3. Conditionally stable system
4. Marginally stable system

Question Number : 82 Question Id : 871112442 Display Question Number : Yes Single Line Question Option : No Option Orientation : Vertical

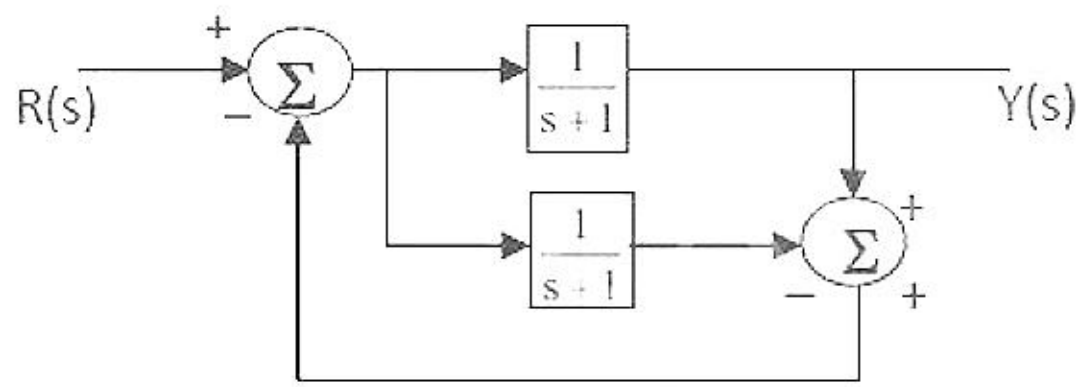

Options :

1. 0
2. $\frac{1}{s+1}$
3. $\frac{1}{s+2}$
4. $\frac{2}{s+3}$

Question Number : 83 Question Id : 871112443 Display Question Number : Yes Single Line Question Option : No Option Orientation : Vertical

If the characteristic equation of a closed-loop system is $s^2 + 2s + 2 = 0$ then the system is

Options :

1. Overdamped
2. Criticallydamped
3. Underdamped
4. Undamped

Question Number : 84 Question Id : 871112444 Display Question Number : Yes Single Line Question Option : No Option Orientation : Vertical

A polynomial $f(x) = a_4 x^4 + a_3 x^3 + a_2 x^2 + a_1 x - a_0$ with all coefficients positive has

Options :

1. No real roots
2. No negative real root
3. Odd number of real roots

Dominant stable closed-loop poles are those

Options :

1. That are close to the imaginary axis of the left s-plane
2. That are far away from the imaginary axis of the left s-plane
3. They are close to the real axis of the s-plane
4. They are far away from the real axis of the s-plane

Question Number : 86 Question Id : 871112446 Display Question Number : Yes Single Line Question Option : No Option Orientation : Vertical

A unity feedback system has the open loop transfer function $G(S) = \frac{1}{(S-1)(S+2)(S+3)}$. The Nyquist plot of G encircles the origin

Options :

1. never
2. once
3. twice
4. thrice

Question Number : 87 Question Id : 871112447 Display Question Number : Yes Single Line Question Option : No Option Orientation : Vertical

Consider the signal flow graph of a control plant shown below. The relationship between b_1 and b_2 to make system uncontrollable is

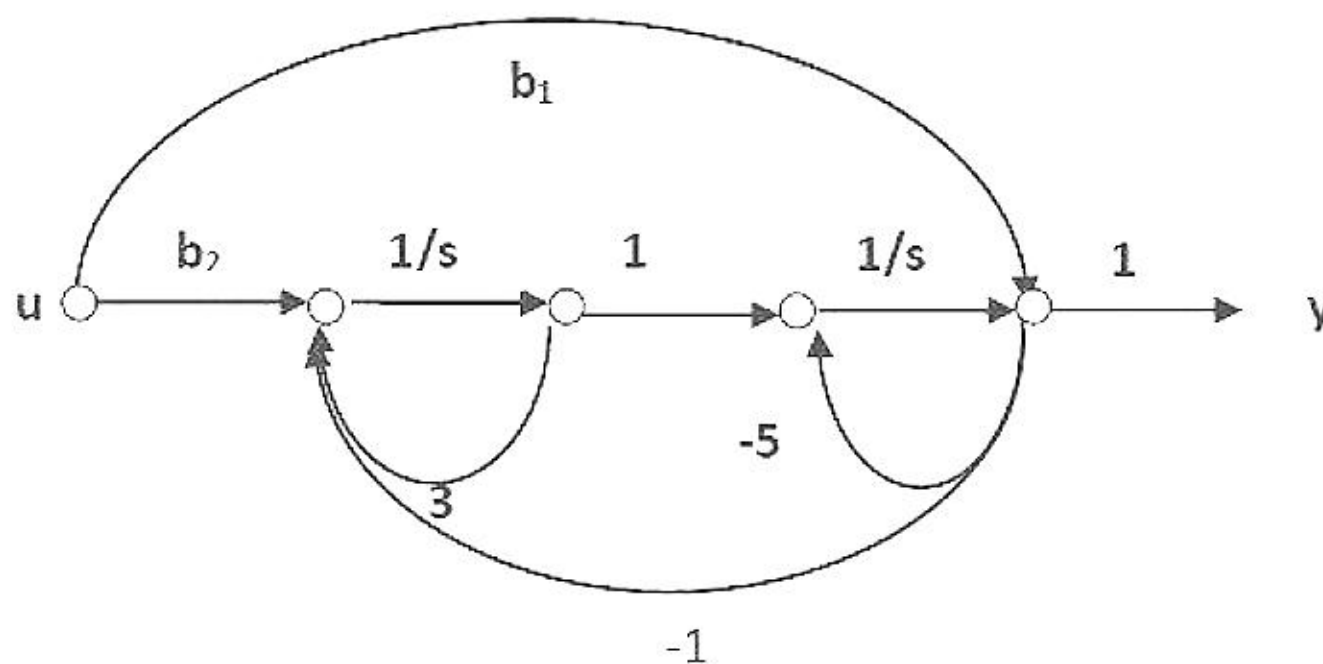

Options :

1. $b_2 = b_1/2$

3.

$$b_2 = 0, b_1 = \infty$$

4.

Question Number : 88 Question Id : 871112448 Display Question Number : Yes Single Line Question Option : No Option Orientation : Vertical

The characteristic equation of a system is $q(s) = s^5 + s^4 - s^3 + s - 1$. The system is

Options :

1. Stable

2. Marginally Stable

3. Unstable

4. Oscillatory

Question Number : 89 Question Id : 871112449 Display Question Number : Yes Single Line Question Option : No Option Orientation : Vertical

For the Bode plot shown in figure, the transfer function is,

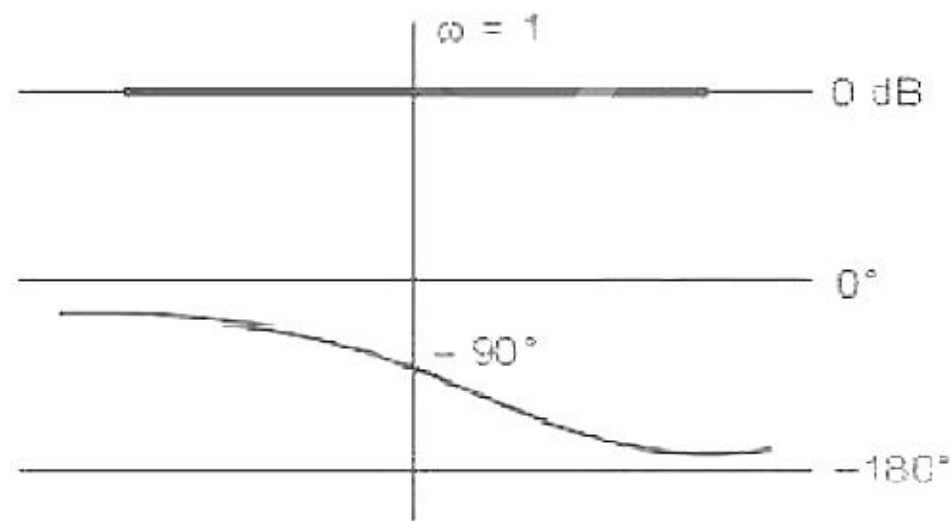

Options :

1. $\frac{1-s}{1+s}$

2. $\frac{1}{s^2}$

3. $\frac{1}{(1+s)^2}$

4. $\frac{1}{s(s+1)}$

Question Number : 90 Question Id : 871112450 Display Question Number : Yes Single Line Question Option : No Option Orientation : Vertical

A unity feedback system has open loop transfer function $G(S)$. The steady state error is zero for

Options :

3. step input and type-0 G(S)
4. ramp input and type-0 G(S)

Question Number : 91 Question Id : 871112451 Display Question Number : Yes Single Line Question Option : No Option Orientation : Vertical

A certain linear time invariant system has the state and the output equations as given below:

$$\begin{bmatrix} \dot{x}_1 \\ \dot{x}_2 \end{bmatrix} = \begin{bmatrix} 1 & -1 \\ 0 & 1 \end{bmatrix} \begin{bmatrix} x_1 \\ x_2 \end{bmatrix} + \begin{bmatrix} 0 \\ 1 \end{bmatrix} u$$

$$y = [1 \quad 1] \begin{bmatrix} x_1 \\ x_2 \end{bmatrix}$$

if $x_1(0) = 1, x_2(0) = -1, u(0) = 0$, then $\left. \frac{dy}{dt} \right|_{t=0}$ is _____.

Options :

1. 0.5
2. 0.75
3. 1
4. 1.25

Question Number : 92 Question Id : 871112452 Display Question Number : Yes Single Line Question Option : No Option Orientation : Vertical

ASK, FSK and PSK are examples of which of the following encoding?

Options :

1. Analog to digital
2. Digital to digital
3. Analog to analog
4. Digital to analog

Question Number : 93 Question Id : 871112453 Display Question Number : Yes Single Line Question Option : No Option Orientation : Vertical

A component used to connect a balance line to an unbalanced line is called a

Options :

3. Balun
4. Waveguide

Question Number : 94 Question Id : 871112454 Display Question Number : Yes Single Line Question Option : No Option Orientation : Vertical

The de-emphasis filter in a FM receiver increases the output SNR because

Options :

1. The de-emphasis filter decreases the output noise power
2. The de-emphasis filter enhances the signal quality
3. The de-emphasis filter increases the bandwidth of the transmitted signal
4. The de-emphasis filter increases the output noise power

Question Number : 95 Question Id : 871112455 Display Question Number : Yes Single Line Question Option : No Option Orientation : Vertical

Choose the correct one from among the alternatives A, B, C, D after matching an item in group 1 with the most appropriate item in group 2.

Group 1

- P. Ring modulator
- Q. VCO
- R. Foster-Seely
- S. Mixer

Group2

1. Clock recovery
2. Demodulation of FM
3. Frequency Discriminator Conversion
4. Summing the two inputs
5. Generation of FM
6. Generation of DSB-SC

Options :

1. P-1 Q-6 R- 6 S-5
2. P-3 Q-5 R- 2 S-6
3. P-2 Q-2 R- 3 S-1
4. P-4 Q- 3 R-2 S-3

Question Number : 96 Question Id : 871112456 Display Question Number : Yes Single Line Question Option : No Option Orientation : Vertical

The bit rate of digital communication system is R Kbits/s. The modulation used is 16 QAM. The minimum bandwidth required for ISI free transmission is?

2. $R/4$ Hz
3. $R/4$ kHz
4. $R/4$ Hz

Question Number : 97 Question Id : 871112457 Display Question Number : Yes Single Line Question Option : No Option Orientation : Vertical

For a bit rate of 8 Kbps, the best possible values of transmitted frequencies in a coherent binary FSK 4

Options :

1. 16 kHz and 20 kHz
2. 20 kHz and 32 kHz
3. 20 kHz and 40 kHz
4. 40 kHz and 32 kHz

Question Number : 98 Question Id : 871112458 Display Question Number : Yes Single Line Question Option : No Option Orientation : Vertical

Which of the following statements of matched filter is incorrect?

Options :

1. It maximizes the SNR at the detected instant
2. It minimizes the error at the output
3. It produces ISI
4. It's impulse response depends on the signal shape

Question Number : 99 Question Id : 871112459 Display Question Number : Yes Single Line Question Option : No Option Orientation : Vertical

The image channel rejection in a super heterodyne receiver comes from

Options :

1. Detector, RF and IF stages
2. Detector and RF stage only
3. RF stage only
4. IF stage only

Options :

1. SDMA
2. FDMA
3. CDMA
4. TDMA

Question Number : 101 Question Id : 871112461 Display Question Number : Yes Single Line Question Option : No Option Orientation : Vertical

The Nyquist sampling rate for a signal

$$s(t) = \frac{\sin(500\pi t)}{\pi t} \times \frac{\sin(700\pi t)}{\pi t} \text{ is given by}$$

Options :

1. 400 Hz
2. 600 Hz
3. 1200 Hz
4. 1400 Hz

Question Number : 102 Question Id : 871112462 Display Question Number : Yes Single Line Question Option : No Option Orientation : Vertical

Compression in PCM refers to relative compression of

Options :

1. higher signal amplitudes
2. lower signal amplitudes
3. lower signal frequencies
4. higher signal frequencies

Question Number : 103 Question Id : 871112463 Display Question Number : Yes Single Line Question Option : No Option Orientation : Vertical

A 400 W carrier is amplitude modulated with $m = 0.75$. The total power in AM is

Options :

1. 400 W
2. 512.5 W

Question Number : 104 Question Id : 871112464 Display Question Number : Yes Single Line Question Option : No Option Orientation : Vertical

Which of the following is the indirect way of FM generation?

Options :

1. Reactance bipolar transistor modulator
2. Armstrong modulator
3. Varactor diode modulator
4. Reactance FM modulator

Question Number : 105 Question Id : 871112465 Display Question Number : Yes Single Line Question Option : No Option Orientation : Vertical

In commercial TV transmission in India, picture and speech signals are modulated respectively as

Options :

1. VSB and VSB
2. VSB and SSB
3. VSB and FM
4. FM and VSB

Question Number : 106 Question Id : 871112466 Display Question Number : Yes Single Line Question Option : No Option Orientation : Vertical

In a PCM system, if we increase the quantization levels from 2 to 8, how do the relative bandwidth requirements vary?

Options :

1. Get doubled
2. Get tripled
3. Remains same
4. Become eight times

Question Number : 107 Question Id : 871112467 Display Question Number : Yes Single Line Question Option : No Option Orientation : Vertical

A time varying magnetic field creates

Options :

3. Electric field that is conservative.
4. Electric field that is non-conservative.

Question Number : 108 Question Id : 871112468 Display Question Number : Yes Single Line Question Option : No Option Orientation : Vertical

For a rectangular waveguide with $a = 2$ cm and $b = 1$ cm. the cut-off wavelength for TE_{10} mode will be

Options :

1. 2 cm
2. 1 cm
3. 4 cm
4. 3 cm

Question Number : 109 Question Id : 871112469 Display Question Number : Yes Single Line Question Option : No Option Orientation : Vertical

Which one of the following modes does not exist in waveguides?

Options :

1. TE_{10} mode
2. TE_{11} mode
3. TEM mode
4. TE_{01} mode

Question Number : 110 Question Id : 871112470 Display Question Number : Yes Single Line Question Option : No Option Orientation : Vertical

The dominant mode in a rectangular waveguide is TE_{10} . because this mode has

Options :

1. No attenuation
2. No cut-off
3. No magnetic field component
4. The highest cut-off wavelength

Options :

1. a decrease in the value of reactance
2. an increase in the value of reactance
3. no change in the reactance value
4. no change in the impedance value

Question Number : 112 Question Id : 871112472 Display Question Number : Yes Single Line Question Option : No Option Orientation : Vertical

The unit of $\nabla \times H$ is

Options :

1. Ampere
2. Ampere /meter
3. Ampere / m²
4. Ampere-meter

Question Number : 113 Question Id : 871112473 Display Question Number : Yes Single Line Question Option : No Option Orientation : Vertical

The propagation constant of a lossy transmission line is $(2 + j5) \text{ m}^{-1}$ and its characteristic impedance is $(50 - j0) \Omega$ at $\omega = 106 \text{ rad s}^{-1}$. The values of the line constants L, C, R, G are

Options :

1. $L = 200 \mu\text{H/m}$, $C = 0.1 \mu\text{F/m}$, $R = 50 \Omega/\text{m}$, $G = 0.02 \text{ S/m}$
2. $L = 250 \mu\text{H/m}$, $C = 0.1 \mu\text{F/m}$, $R = 100 \Omega/\text{m}$, $G = 0.04 \text{ S/m}$
3. $L = 200 \mu\text{H/m}$, $C = 0.2 \mu\text{F/m}$, $R = 100 \Omega/\text{m}$, $G = 0.02 \text{ S/m}$
4. $L = 250 \mu\text{H/m}$, $C = 0.2 \mu\text{F/m}$, $R = 50 \Omega/\text{m}$, $G = 0.04 \text{ S/m}$

Question Number : 114 Question Id : 871112474 Display Question Number : Yes Single Line Question Option : No Option Orientation : Vertical

A broadside array consisting of 200 cm wavelength with 10 half-wave dipole spacing 10 cm. And if each array element feeding with 1 Amp current and operating at same frequency, then what is the half power beam width?

Options :

3. 10°
4. 15°

Question Number : 115 Question Id : 871112475 Display Question Number : Yes Single Line Question Option : No Option Orientation : Vertical

Degenerate modes in a waveguide are characterized by

Options :

1. same cut off frequencies but with different field distributions
2. same cut off frequencies but with same field distributions
3. different cut off frequencies but with same field distributions
4. different cut off frequencies but with different field distributions

Question Number : 116 Question Id : 871112476 Display Question Number : Yes Single Line Question Option : No Option Orientation : Vertical

If a plane electromagnetic wave satisfies the equation $\frac{\partial^2 E_x}{\partial z^2} = C^2 \frac{\partial^2 E_x}{\partial t^2}$. The wave propagates in the

Options :

1. X-direction
2. Z-direction
3. Y-direction
4. XZ plane at an angle of 45° between the X and Z direction

Question Number : 117 Question Id : 871112477 Display Question Number : Yes Single Line Question Option : No Option Orientation : Vertical

The magnitudes of the open circuit and short circuit input impedances of a transmission line are 100Ω and 25Ω respectively. The characteristic impedance of the line is

Options :

1. 25Ω
2. 50Ω
3. 75Ω
4. 100Ω

Options :

1. $\frac{j\omega\mu}{\sigma}$
2. $\frac{j\omega\epsilon}{\mu}$
3. $\sqrt{\frac{j\omega\mu}{(\sigma+j\omega\epsilon)}}$
4. $\sqrt{\frac{\mu}{\epsilon}}$

Question Number : 119 Question Id : 871112479 Display Question Number : Yes Single Line Question Option : No Option Orientation : Vertical

The reflection co-efficient on a line is $0.2-45^\circ$. The SWR of the line is

Options :

1. 0.8
2. 1.5
3. 1.2
4. 1.3

Question Number : 120 Question Id : 871112480 Display Question Number : Yes Single Line Question Option : No Option Orientation : Vertical

A helical antenna is used for satellite tracking because of its

Options :

1. Circular polarization
2. Maneuverability
3. Broad bandwidth
4. Good front to back ratio