

SECTION - A

1. In questions 1.1 to 1.7 below, one or more of the alternatives are correct. Write the code letter(s) a, b, c, d corresponding to the correct alternative(s) in the answer book. Marks will be given only if all the correct alternatives have been selected and no incorrect alternative is picked up.

- 1.1 The eigen vector(s) of the matrix

$$\begin{pmatrix} 0 & 0 & \alpha \\ 0 & 0 & 0 \\ 0 & 0 & 0 \end{pmatrix}, \alpha \neq 0 \text{ is (are)}$$

- (a) $(0, 0, \alpha)$ (b) $(\alpha, 0, 0)$ (c) $(0, 0, 1)$ (d) $(0, \alpha, 0)$

- 1.2 The differential equation

$$\frac{d^2y}{dx^2} + \frac{dy}{dx} + \sin y = 0 \text{ is:}$$

- (a) linear (b) non-linear (c) homogeneous (d) of degree two

- 1.3 Simpson's rule for integration gives exact result when $f(x)$ is a polynomial of degree

- (a) 1 (b) 2 (c) 3 (d) 4

- 1.4 Which of the following is (are) valid FORTRAN 77 statement(s)?

- (a) DO 13 I = 1 (b) A = DIM ***7
(c) READ = 15.0 (d) GO TO 3 = 10

- 1.5 Fourier series of the periodic function (period 2π) defined by

$$f(x) = \begin{cases} 0, & -p < x < 0 \\ x, & 0 < x < p \end{cases} \text{ is}$$

$$\frac{p}{4} + \sum \left[\frac{1}{\pi n^2} (\cos n\pi - 1) \cos nx - \frac{1}{n} \cos n\pi \sin nx \right]$$

But putting $x = \pi$, we get the sum of the series.

$$1 + \frac{1}{3^2} + \frac{1}{5^2} + \frac{1}{7^2} + \dots \text{ is}$$

- (a) $\frac{\pi^2}{4}$ (b) $\frac{\pi^2}{6}$ (c) $\frac{\pi^2}{8}$ (d) $\frac{\pi^2}{12}$

- 1.6 Which of the following improper integrals is (are) convergent?

$$(a) \int_0^1 \frac{\sin x}{1 - \cos x} dx \quad (b) \int_0^\infty \frac{\cos x}{1+x} dx \quad (c) \int_0^\infty \frac{x}{1+x^2} dx \quad (d) \int_0^1 \frac{1 - \cos x}{x^5} dx$$

1.7 The function $f(x, y) = x^2y - 3xy + 2y + x$ has

- (a) no local extremum
- (b) one local minimum but no local maximum
- (c) one local maximum but no local minimum
- (d) one local minimum and one local maximum

2. In questions 2.1 to 2.10 below, each blank (_____) is to be suitably filled in. In the answer book write the question number and the answer only. Do not copy the question. Also, no explanations for the answers are to be given.

2.1 $\lim_{x \rightarrow 0} \frac{x(e^x - 1) + 2(\cos x - 1)}{x(1 - \cos x)}$ is _____

2.2 The radius of convergence of the power series

$$\sum_{m=0}^{\infty} \frac{(3m)!}{(m!)^3} x^{3m} \text{ is: } \underline{\hspace{2cm}}$$

2.3 If the linear velocity \vec{V} is given by

$$\vec{V} = x^2yi + xyz\hat{j} - yz^2k,$$

The angular velocity $\vec{\omega}$ at the point (1, 1, -1) is _____

2.4 Given the differential equation, $y' = x - y$ with the initial condition $y(0) = 0$. The value of $y(0.1)$ calculated numerically upto the third place of decimal by the second order Runge-Kutta method with step size $h = 0.1$ is _____

2.5 For $X = 4.0$, the value of I in the FORTRAN 77 statement $I = -2 ** 2 + \frac{5.0 * X}{X * 3} + \frac{3}{4}$ is _____

2.6 The value of the double integral $\int_0^1 \int_0^1 \frac{x}{1+y^2} dx dy$ is _____

2.7 If $A = \begin{pmatrix} 1 & 0 & 0 & 1 \\ 0 & -1 & 0 & -1 \\ 0 & 0 & i & i \\ 0 & 0 & 0 & -i \end{pmatrix}$ the matrix A^{-1} , calculated by the use of Cayley-Hamilton theorem or otherwise, is _____

2.8 Given $\vec{V} = x \cos^2 y \hat{i} + x^2 e^z \hat{j} + z \sin^2 y \hat{k}$ and S the surface of a unit cube with one corner at the origin and edges parallel to the coordinate axes, the value of integral

$$\int \int \int_S \vec{V} \cdot \hat{n} dS \text{ is } \underline{\hspace{2cm}}$$

2.9 The differential equation $y'' + y = 0$ is subjected to the boundary conditions.

$$y(0) = 0 \qquad y(\lambda) = 0$$

In order that the equation has non-trivial solution(s), the general value of λ is _____

2.10 The Laplace transform of the periodic function $f(t)$ described by the curve below, i.e.,

$$f(t) = \begin{cases} \sin t & \text{if } (2n-1)\pi \leq t \leq 2n\pi \quad (n = 1, 2, 3, \dots) \\ 0 & \text{otherwise} \end{cases}$$

is _____

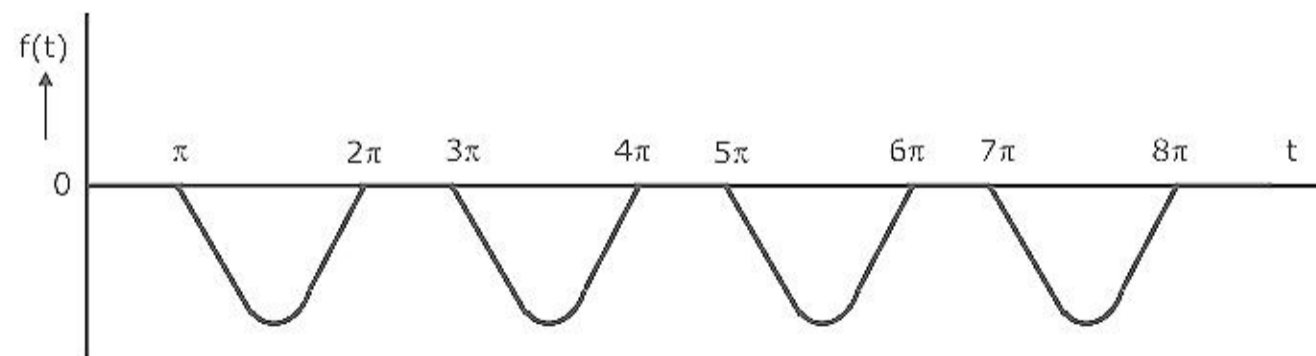

SECTION II – A

INSTRUCTIONS: There are THREE questions in this Section. Question 6 has 8 parts, 7 has 10 parts, and 8 has 7 parts. Each part of a question carries 2 marks. There may be more than one correct alternative the multiple-choice questions. Credit will be given if only all the correct alternatives have been indicated.

6.

6.1. Identify the logic function performed by the circuit shown in figure.

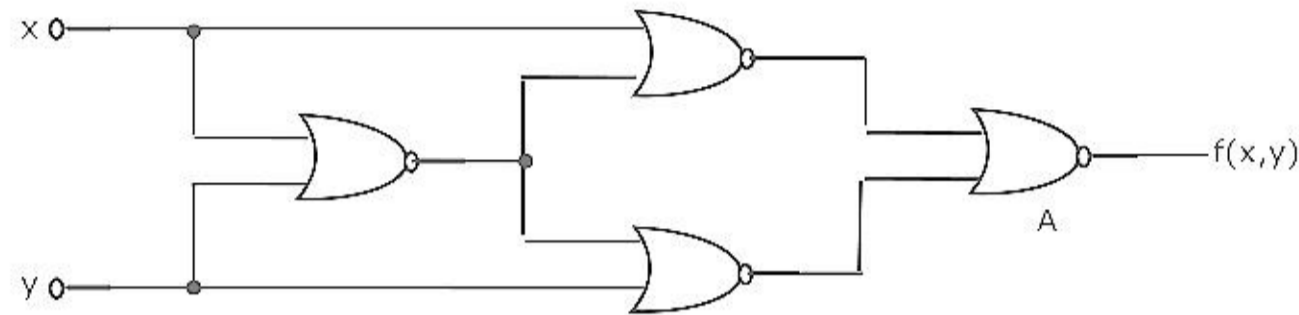

- (a) exclusive OR (b) exclusive NOR (c) NAND
 (d) NOR (e) None of the above

6.2. If the state machine described in figure, should have a stable state, the restriction on the inputs is given by

- (a) $a.b = 1$ (b) $a + b = 1$ (c) $\bar{a} + \bar{b} = 0$ (d) $\bar{a}.b = 1$
 (e) $\overline{a + b} = 1$

6.3. For the initial state of 000, the function performed by the arrangement of the J-K flip-flops in figure is:

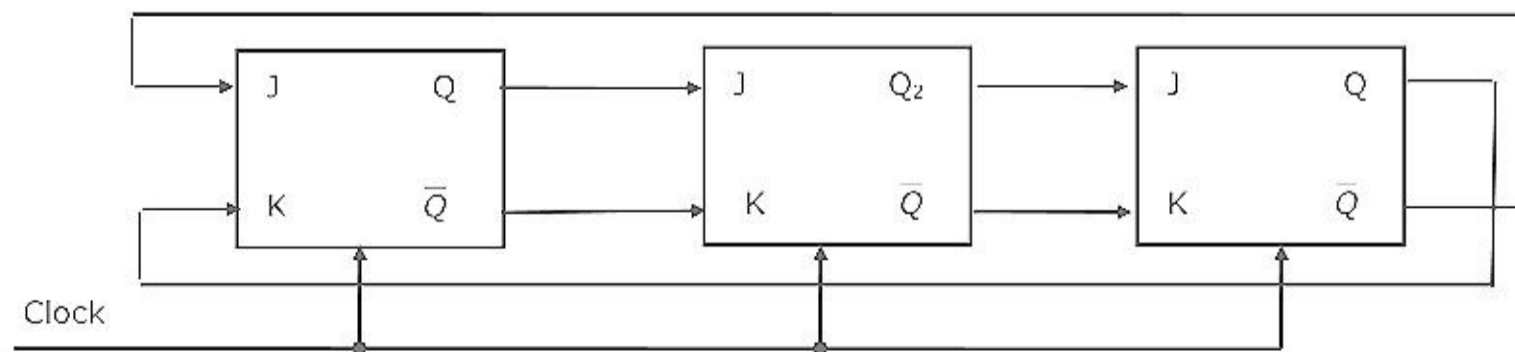

- (a) Shift Register (b) Mod-3 Counter (c) Mod-6 Counter
 (d) Mod-2 Counter (e) None of the above

- 6.4. Assume that each character code consists of 8 bits. The number of characters that can be transmitted per second through an asynchronous serial line at 2400 baud rate, and with two stop bits, is
- (a) 109 (b) 216 (c) 218 (d) 219
 (e) 240
- 6.5. Convert the following numbers in the given bases into their equivalents in the desired bases.
- (a) $110.101_2 = x_{10}$
 (b) $1118_{10} = y_H$
- 6.6. A ROM is used to store the Truth table for a binary multiple unit that will multiply two 4-bit numbers. The size of the ROM (number of words \times number of bits) that is required to accommodate the Truth table is M words \times N bits. Write the values of M and N.
- 6.7. A certain moving arm disk storage, with one head, has the following specifications.
- Number of tracks/recording surface = 200
 Disk rotation speed = 2400 rpm
 Track storage capacity = 62,500 bits
 The average latency of this device is P msec and the data transfer rate is Q bits/sec.
 Write the value of P and Q.
- 6.8. The details of an interrupt cycle are shown in figure.

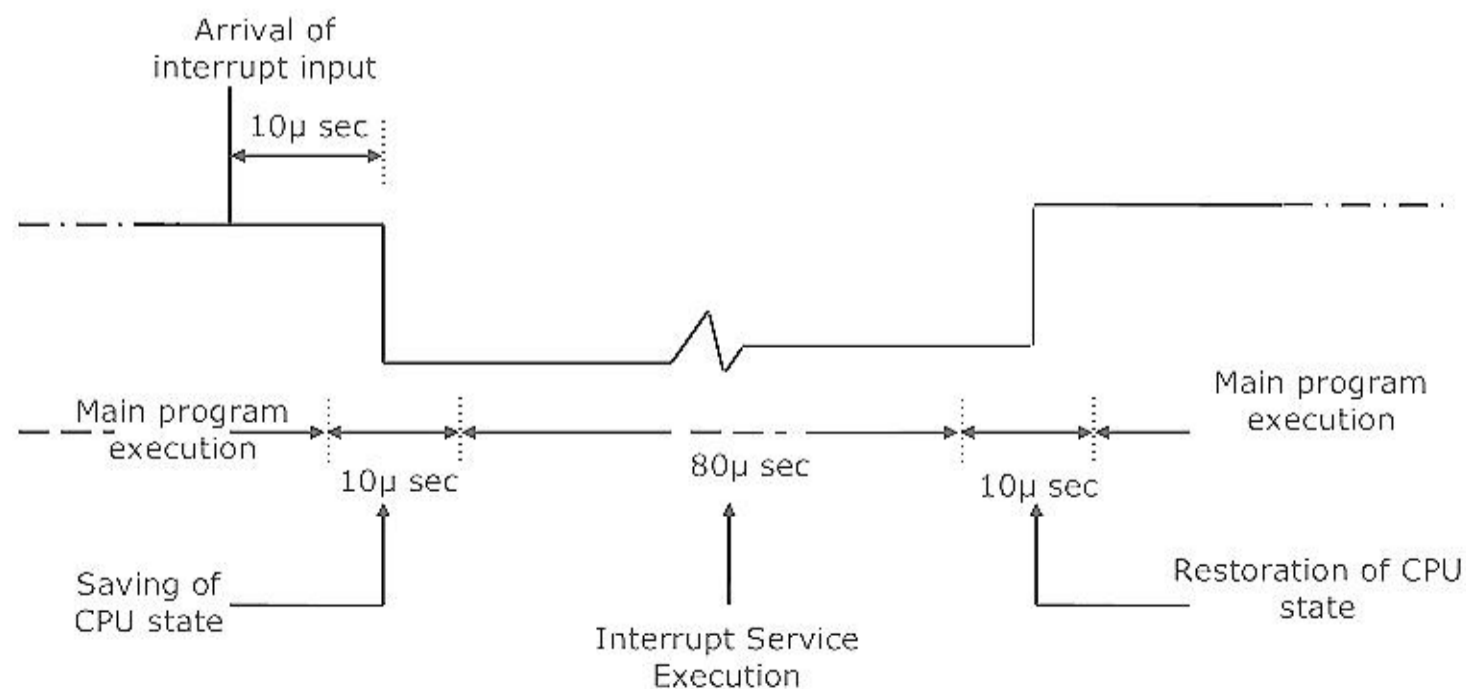

Given that an interrupt input arrives every 1 msec, what is the percentage of the total time that the CPU devotes for the main program execution.

7. **Note:** For sub-questions 7.1 to 7.3, refer to the PASCAL program shown below.

```
Program PARAM (input, output);
var m, n : integer;
procedure P (var, x, y : integer);
    var m : integer;
    begin
        m := 1;
        x := y + 1
    end;
procedure Q (x:integer; vary : integer);
    begin
        x:=y+1;
    end;
begin
    m:=0; P(m,m); write (m);
    n:=0; Q(n*1,n); write (n)
end
```

7.1. The value of m, output by the program PARAM is:

- (a) 1, because m is a local variable in P
- (b) 0, because m is the actual parameter that corresponds to the formal parameter in p
- (c) 0, because both x and y are just reference to m, and y has the value 0
- (d) 1, because both x and y are just references to m which gets modified in procedure P
- (e) none of the above

7.2. The value of n, output by the program PARAM is:

- (a) 0, because n is the actual parameter corresponding to x in procedure Q.
- (b) 0, because n is the actual parameter to y in procedure Q.
- (c) 1, because n is the actual parameter corresponding to x in procedure Q.
- (d) 1, because n is the actual parameter corresponding to y in procedure Q.
- (e) none of the above

7.3. What is the scope of m declared in the main program?

- (a) PARAM, P, Q (b) PARAM, P (c) PARAM, Q
- (d) P, Q (e) none of the above

7.4. What does the following code do?

```
var a, b : integer;  
begin  
    a:=a+b;  
    b:=a-b;  
    a:=a-b  
end;
```

- (a) exchanges a and b
- (b) doubles a and stores in b
- (c) doubles b and stores in a
- (d) leaves a and b unchanged
- (e) none of the above

7.5. For the program segment given below, which of the following are true?

```
program main (output);  
type link = ^data;  
    data = record  
        d : real;  
        n : link  
    end;  
var ptr : link;  
begin  
    new (ptr);  
    ptr:=nil;  
    .ptr^.d:=5.2;  
    write ln(ptr)  
end.
```

- (a) The program leads to compile time error
- (b) The program leads to run time error
- (c) The program outputs 5.2
- (d) The program produces error relating to nil pointer dereferencing
- (e) None of the above

7.6. A simple two-pass assembler does the following in the first pass:

- (a) It allocates space for the literals.
- (b) It computes the total length of the program
- (c) It builds the symbol table for the symbols and their values.
- (d) It generates code for all the load and store register instructions.
- (e) None of the above.

- 7.7. A part of the system software, which under all circumstances must reside in the main memory, is:
 (a) text editor (b) assembler (c) linker (d) loader
 (e) none of the above
- 7.8. The root directory of a disk should be placed
 (a) at a fixed address in main memory (b) at a fixed location on the disk
 (c) anywhere on the disk
 (d) at a fixed location on the system disk (e) anywhere on the system disk
- 7.9. Consider a system having m resources of the same type. These resources are shared by 3 processes A, B and C, which have peak demands of 3, 4 and 6 respectively. For what value of m deadlock will not occur?
 (a) 7 (b) 9 (c) 10 (d) 13
 (e) 15
- 7.10. Assume that the following jobs are to be executed on a single processor system

Job Id	CPU Burst time
p	4
q	1
r	8
s	1
t	2

The jobs are assumed to have arrived at time 0^+ and in the order p, q, r, s, t. calculate the departure time (completion time) for job p if scheduling is round robin with time slice 1.

- (a) 4 (b) 10 (c) 11 (d) 12
 (e) None of the above
- 8.**
- 8.1. Consider a simple connected graph G with n vertices and n -edges ($n > 2$). Then, which of the following statements are true?
 (a) G has no cycles.
 (b) The graph obtained by removing any edge from G is not connected.
 (c) G has at least one cycle.
 (d) The graph obtained by removing any two edges from G is not connected.
 (e) None of the above.

- 8.2. The proposition $P \wedge (\sim p \vee q)$ is:
- (a) a tautology (b) logically equivalent to $p \wedge q$
(c) logically equivalent to $p \vee q$ (d) a contradiction
(e) none of the above
- 8.3. Let S be an infinite set and S_1, \dots, S_n be sets such that $S_1 \cup S_2 \cup \dots \cup S_n = S$. Then,
- (a) at least one of the set S_i is a finite set
(b) not more than one of the set S_i can be finite
(c) at least one of the sets S_i is an infinite set
(d) not more than one of the sets S_i can be infinite
(e) None of the above
- 8.4. Let A be a finite set of size n . The number of elements in the power set of $A \times A$ is:
- (a) 2^{2^n} (b) 2^{n^2} (c) $(2^n)^2$ (d) $(2^2)^n$
(e) None of the above
- 8.5. The less-than relation, $<$, on reals is
- (a) a partial ordering since it is asymmetric and reflexive
(b) a partial ordering since it is antisymmetric and reflexive
(c) not a partial ordering because it is not asymmetric and not reflexive
(d) not a partial ordering because it is not antisymmetric and reflexive
(e) none of the above
- 8.6. Let A and B be sets with cardinalities m and n respectively. The number of one-one mappings (injections) from A to B , when $m < n$, is:
- (a) m^n (b) ${}^n P_m$ (c) ${}^m C_n$ (d) ${}^n C_m$
(e) ${}^m P_n$
- 8.7. $\sum_{1 \leq k \leq n} O(n)$, where $O(n)$ stands for order n is:
- (a) $O(n)$ (b) $O(n^2)$ (c) $O(n^3)$ (d) $O(3n^2)$
(e) $O(1.5n^2)$

SECTION II - B

INSTRUCTIONS: There are TEN questions in this section. Each question carries 5 marks. Attempt all questions.

9. Assume that only half adders are available in your laboratory. Show that any binary Boolean function can be implemented using half adders only.
10. The instruction format of a CPU is:

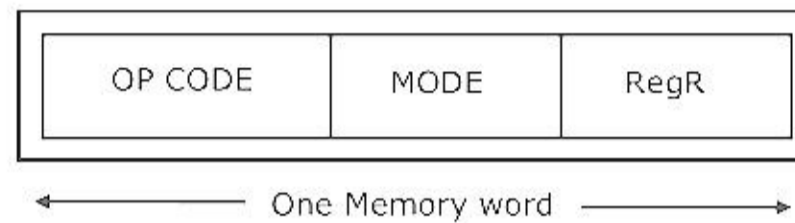

Mode and RegR together specify the operand. RegR specifies a CPU register and Mode specifies an addressing mode. In particular, Mode = 2 specifies that 'the register RegR contains the address of the operand, after fetching the operand, the contents of RegR are incremented by 1'.

An instruction at memory location 2000 specifies Mode = 2 and the RegR refers to program counter (PC).

- (a) What is the address of the operand?
- (b) Assuming that this is a non-jump instruction, what are the contents of PC after the execution of this instruction?
11. In the three-level memory hierarchy shown in the following table, p_i denotes the probability that an access request will refer to M_i .

Hierarchy Level (M_i)	Access Time (t_i)	Probability of access (p_i)	Page Transfer time (T_i)
M_1	10^{-6}	0.99000	0.001 sec
M_2	10^{-5}	0.00998	0.1 sec
M_3	10^{-4}	0.00002	--

If a miss occurs at level M_i , a page transfer occurs from M_{i-1} to M_i and the average time required for such a page swap is T_i . Calculate the average time t_A required for a processor to read one word from this memory system.

12. The following Pascal program segments finds the largest number in a two-dimensional integer array $A[0 \dots n-1, 0 \dots n-1]$ using a single loop. Fill up the boxes to complete the program and write against \boxed{A} , \boxed{B} , \boxed{C} and \boxed{D} in your answer book. Assume that max is a variable to store the largest value and i,j are the indices to the array.

```

begin
    max:=  $\boxed{A}$ , i:=0,j:=0;
    while  $\boxed{B}$  do
        begin
            if A[i,j]>max then max:=A[i,j]
            if  $\boxed{C}$  then j:=j+1
            else begin
                j:=0;
                i:=  $\boxed{D}$ 
            end
        end
    end
end.

```

13. Consider a singly linked list having n nodes. The data items d_1, d_2, \dots, d_n are stored in these n nodes. Let X be a pointer to the j-th node ($1 \leq j \leq n$) in which d_j is stored. A new data item d stored in node with address Y is to be inserted. Give an algorithm to insert d into the list to obtain a list having items $d_1, d_2, \dots, d_{j-1}, d, d_j, \dots, d_n$ in the order without using the header.

14. An ISAM (indexed sequential) file consists of records of size 64 bytes each, including key field of size 14 bytes. An address of a disk block takes 2 bytes. If the disk block size is 512 bytes and there are 16 K records, compute the size of the data and index areas in terms of number of blocks. How many levels of tree do you have for the index?

15. Consider the recursive algorithm given below:

```

procedure bubblersort (n);
var i,j: index; temp : item;
begin
    for i:=1 to n-1 do
        if A[i] > A [i+1] then
begin
    temp : A[i];
    A[i]:=A[i+1];

```

```

    A[i+1]:=temp
  end;
  bubblesort (n -1 )
end

```

Let a_n be the number of times the 'if...then...' Statement gets executed when the algorithm is run with value n. Set up the recurrence relation by defining a_n in terms of a_{n-1} . Solve for a_n .

16. Prove by the principal of mathematical induction that for any binary tree, in which every non-leaf node has 2 descendants, the number of leaves in the tree is one more than the number of non-leaf nodes.
17. Out of a group of 21 persons, 9 eat vegetables, 10 eat fish and 7 eat eggs : 5 persons eat all three. How many persons eat at least two out the three dishes?
18. Show that proposition C is a logical consequence of the formula

$$A \wedge (A \rightarrow (B \vee C)) \wedge (B \rightarrow \sim A)$$
 Using truth tables.

SECTION: II - C

INSTRUCTIONS: There are TEN questions in this section. Each question carries 5 marks. Attempt any FIVE questions. In case more than five questions are attempted, the first five answers alone will be evaluated.

19. A control algorithm is implemented by the NAND – gate circuitry given in figure below, which A and B are state variable implemented by D flip-flops, and P is control input. Develop the state transition table for this controller.

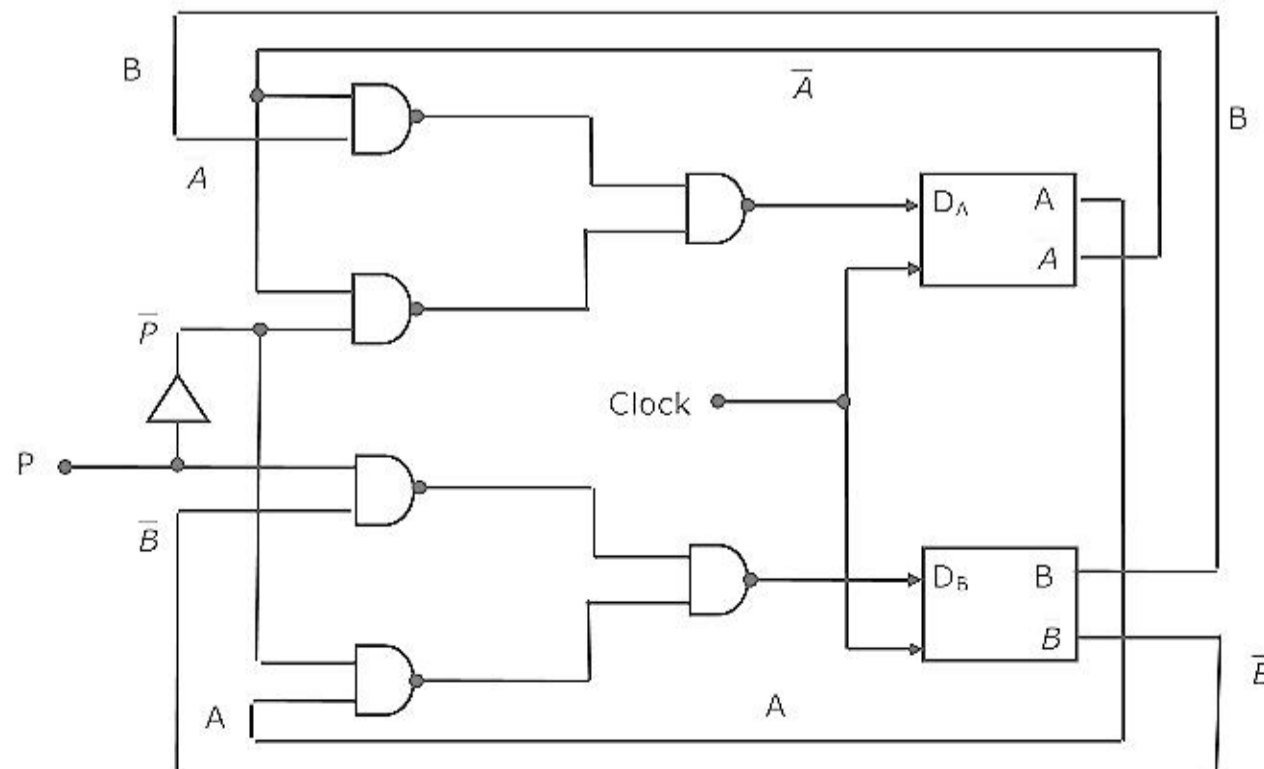

20. Given that the following is an 8085 program segment:
- (a) Identify the function performed by it, and
- (b) List the roles of the registers used and the address referred to by it.

	LHLD	5000
	MVI	B, 5
GET:	IN	20
	MOV	M, A
	INX	H
	DCR	B
	JNZ	GET

21. The following page addresses, in the given sequence, were generated by a program:

1 2 3 4 1 3 5 2 1 5 4 3 2 3

This program is run on a demand paged virtual memory system, with main memory size equal to 4 pages. Indicate the page references for which page faults occurs for the following page replacement algorithms.

- (a) LRU
- (b) FIFO

Assume that the main memory is empty initially.

22. Write a concurrent program using parbegin-parend and semaphores to represent the precedence constraints of the statements S_1 to S_6 , as shown in figure below.

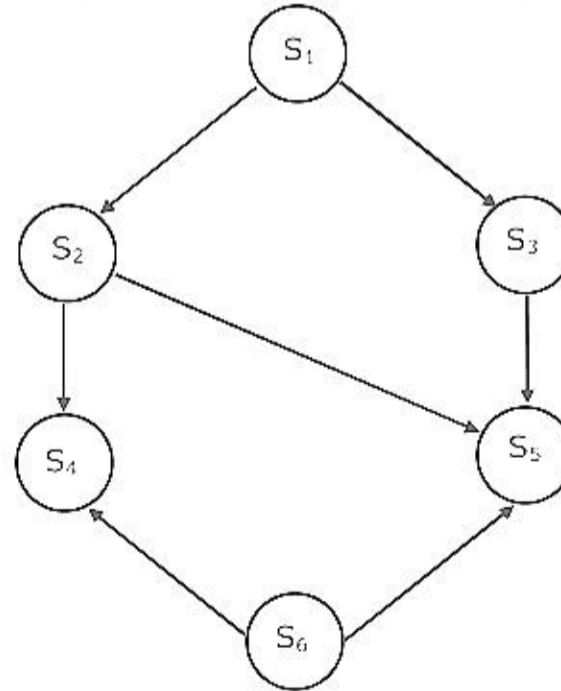

For questions 23 and 24:

The following relations are used to store data about students, courses, enrollment of students in courses and teachers of courses. Attributes for primary key in each relation are marked by '*'.

Students (rollno*, sname, saddr)
courses (cno*, cname)
enroll(rollno*, cno*, grade)
teach(tno*, tname, cao*)

(cno is course number, cname is course name, tno is teacher number, tname is teacher name, sname is student name, etc.)

23. Write a SQL query for retrieving roll number and name of students who got A grade in at least one course taught by teacher named Ramesh for the above relational database.
24. For the relational database given above, the following functional dependencies hold:
- | | |
|-----------------------------------|---------------------------------|
| rollno \rightarrow sname, saddr | cno \rightarrow cname |
| tno \rightarrow tname | rollno, cno \rightarrow grade |
- (a) Is the database in 3rd normal form (3NF)?
(b) If yes, prove that it is in 3 NF. If not, normalize, the relations so that they are in 3 NF (without proving).
25. A simple Pascal like language has only three statements.
- (i) assignment statement e.g. x:=expression
 - (ii) loop construct e.g. for i:=expression to expression do statement.
 - (iii) sequencing e.g. begin statement ;...; statement end
- (a) Write a context-free grammar (CFG) for statements in the above language. Assume that expression has already been defined. Do not use optional parentheses and * operator in CFG.
(b) Show the parse tree for the following statement:
- ```
for j:=2 to 10 do
 begin x:=expr1;
 y:=expr2
 end
```
26. A stack is used to pass parameters to procedures in a procedure call.
- (a) If a procedure P has two parameters as described in procedure definition:  
procedure P (var x :integer; y: integer);  
and if P is called by ; P(a,b)  
State precisely in a sentence what is pushed on stack for parameters a and b.
- (b) In the generated code for the body of procedure P, how will the addressing of formal parameters x and y differ?

27. Draw the state transition of a deterministic finite state automaton which accepts all strings from the alphabet  $\{a, b\}$ , such that no string has 3 consecutive occurrences of the letter b.
28. Let  $(\{p, q\}, *)$  be a semigroup where  $p * p = q$ . Show that:
- (a)  $p * q = q * p$  and
  - (b)  $q * q = q$