

Total Questions (54)

1. A person wear normal spectacles in which the distance of glasses and eyes is approximately 2 cm, then power required is $-5D$. If he wears contact lens, then the required power is :

एक व्यक्ति साधारण चश्मा पहनता है जिसमें कॉचों तथा आंखों के मध्य की दूरी लगभग 2 cm है, तब आवश्यक शक्ति $-5D$ है। यदि वह सम्पर्क लेन्स पहनता है तो आवश्यक शक्ति है—

- (1) $-5.2 D$ (2) $-4.54 D$ (3) $+5.2 D$ (4) $+4.7 D$

Ans. (2)

Sol. Contact lens is more effective, so its required power is less

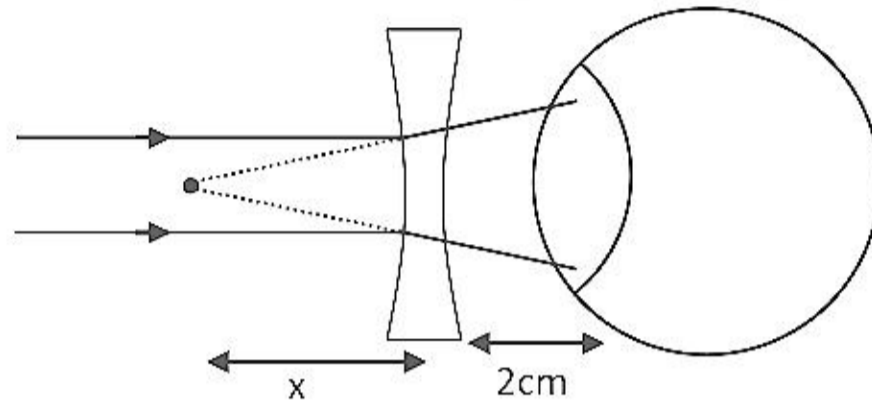

For glasses :-

$$\frac{1}{v} - \frac{1}{u} = \frac{1}{f} \Rightarrow \frac{1}{-\infty} - \frac{1}{-x} = \frac{1}{f}$$

$$f = -x \text{ cm} = -\frac{x}{100}$$

$$\text{power} = \frac{1}{f} = -\frac{100}{x} = -5 \Rightarrow x = 20 \text{ cm}$$

If he used contact lens.

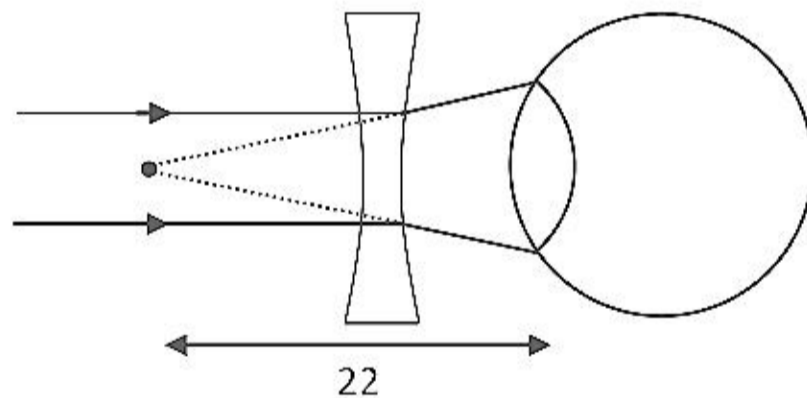

$$v = -\infty, u = -22 \text{ cm}$$

$$\frac{1}{v} - \frac{1}{u} = \frac{1}{f} \Rightarrow \frac{1}{-\infty} - \frac{1}{-22} = \frac{1}{f}$$

$$f = -22, p' = -\frac{100}{22} D = -4.54 D$$

2. If radius of the earth is 6347 km, then what will be difference between acceleration of free fall and acceleration due to gravity near the earth's surface?

यदि पृथ्वी की त्रिज्या 6347 km है तो पृथ्वी सतह के पास मुक्त रूप से गिरने के त्वरण तथा गुरुत्व के कारण त्वरण के बीच क्या अन्तर होगा—

- (1) 0.3400 (2) 0.0340 (3) 0.0034 (4) 0.24

Ans. (1)

Sol. $g = \frac{GM}{R^2} = 9.8$

$$g_{\text{free fall}} = \frac{GM}{R^2} - \omega^2 R = 9.8 - \omega^2 R$$

$$g - g_{\text{free fall}} = \omega^2 R = \left(\frac{2\pi}{T}\right)^2 R$$

$$= \frac{4\pi^2}{(24 \times 60 \times 60)^2} \times 634 \times 10^4 = 0.3401$$

3. A semi circular arc of radius r and a straight wire along the diameter, both are carrying same current i . Find out magnetic force per unit length at point P.

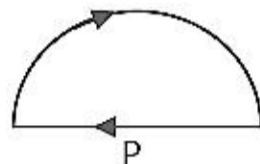

(1*) $\left(\frac{\mu_0 i^2}{4r}\right)$

(2) $\left(\frac{\mu_0 i^2}{2r}\right)$

(3) $\left(\frac{\mu_0 i^2}{r}\right)$

(4) $\left(\frac{2\mu_0 i^2}{r}\right)$

Ans. (1)

Sol. $F = Bi\ell$

$$\frac{F}{\ell} = Bi = \left(\frac{\mu_0 i^2}{4r}\right)$$

4. Find the charge in steady state of the capacitor.

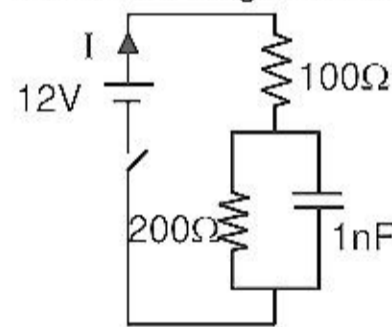

(1) 10 nC

(2) 20 nC

(3) 30 nC

(4) 40 nC

Ans. Option not match.

Sol. Capacitor is in parallel to 100Ω resistance of volt will be

$$V = IR$$

$$\left[\frac{12}{300}\right] 200 = 8V$$

$$q = cV = 8 \text{ nC}$$

Option not match.

5. A current of 10 amp is passing through a metallic wire of cross sectional area $4 \times 10^{-6} \text{ m}^2$. If the density of the aluminum conductor is 2.7 gm/cc considering aluminum gives 1 electrons per atom for conduction find the drift speed of the electrons if molecular weight of aluminum is 27 gm .

(1) $1.6 \times 10^{-4} \text{ m/s}$

(2) $3.6 \times 10^{-4} \text{ m/s}$

(3) $2.6 \times 10^{-4} \text{ m/s}$

(4) $1.5 \times 10^{-4} \text{ m/s}$

Ans. (3)

Sol. $i = neAv_d$

$$n = \frac{N_A}{V} \times \frac{M}{m_w} = \frac{N_A \rho}{m_w} = \frac{6 \times 10^{23} \times 2.7 \times 10^3}{27 \times 10^{-3}} = 6 \times 10^{28}$$

$$v_d = \frac{i}{nA \times e}$$

$$= \frac{10 \times 10^{19}}{6 \times 10^{28} \times 4 \times 10^{-6} \times 1.6} = \frac{100 \times 10^{-4}}{6 \times 4 \times 1.6}$$

$$= \frac{100 \times 10^{-4}}{9.6 \times 4} = 2.6 \times 10^{-4} \text{ m/s}$$

6. If speed of sound in air is 330 m/s then find the number of tones present in an open organ pipe of length 1 m whose frequency is ≤ 1000 .

(1) 2 (2) 4 (3) 8 (4) 6

Ans. (4)

Sol. fundamental frequency $f = \frac{v}{2\ell} = \frac{330}{2 \times 1} = 165 \text{ Hz}$

$$\therefore \text{number of overtones allowed} = \frac{1000}{165} = 6$$

7. An electron is revolving in $n = 3$ orbit. What will be the magnetic field at the centre of hydrogen atom.

(1) 0.1 T (2) 5 T (3) 0.5 T (4) 0.05 T

Ans. (4)

Sol. $B = \frac{\mu_0 i}{2r}$

$$= \frac{\mu_0}{2r} \times \frac{eV}{2\pi r} = \frac{\mu_0 eV}{4\pi r^2}$$

$$V = 2.18 \times 10^6 \times \frac{1}{3} = 0.73 \times 10^6 = 7.3 \times 10^5 \text{ m/s}$$

$$r = 0.529 \text{ \AA} \times \frac{3^2}{1} = 4.761 \text{ \AA}$$

$$B = \frac{10^{-7} \times 1.6 \times 10^{-19} \times 7.3 \times 10^5}{4.761 \times 4.761 \times 10^{-20}} = 0.0515 \text{ T}$$

8. A light of wavelength 500 nm is incident on a young's double slit. The distance between slits and screen is $D = 1.8$ m and distance between slits is $d = 0.4$ mm. If screen moves with a speed 4 m/s, with what speed first maxima will move?

(1*) 5 mm/s (2) 4 mm/s (3) 3 mm/s (4) 2 mm/s

Ans. (1)

Sol. $\beta = \frac{\lambda D}{d}$

Differentiate both sides

$$\frac{d\beta}{dt} = \frac{\lambda}{d} \frac{dD}{dt}$$

$$V_B = \frac{500 \times 10^{-9}}{4 \times 10^{-4}} \times 4$$

$$= 5 \times 10^{-3} \text{ m/s} = 5 \text{ mm/s}$$

9. A electron collides elastically with H-like atom and excites it from ground state to $n = 3$. Find out the energy transfer to H-like atom
 (1) 12.1 eV (2) 10.2 eV (3) 12.75 eV (4) 10 eV

Ans. (1)

10. A transformer with turns ratio $\frac{N_1}{N_2} = \frac{50}{1}$ is connected to a 120 volt AC supply. If primary and secondary circuit resistance are 1.5 k Ω and 1 Ω respectively then find out power out put
 (1) 5.76 W (2) 11.4 W (3) 2.89 W (4) 7.56 W

Ans. (1)

Sol.
$$\frac{V_2}{V_1} = \frac{N_2}{N_1}$$

$$\frac{V_2}{120} = \frac{1}{50}$$

$$V_2 = \frac{12}{5}$$

Let transformer ideal

$$P_{in} = P_{out}$$

$$P_{out} = \frac{V_2^2}{R_2} = \frac{(12/5)^2}{10} = \frac{144}{25 \times 1}$$

$$= \frac{144}{25} = 5.76W$$

11. Modern treatment method P.E.T. is based on !
 (1) proton emission (2*) positron emission
 (3) β^- emission (4) particle emission

Ans. (2)

Sol. P.E.T. = positron emission tomography is a nuclear medicine functional imaging technique used to observe metabolic processes to diagnosis of disease
 $F^{18} \rightarrow$ positron + γ rays, used to detect cancer, heart prob. brain dis-order

12. A gun applies a force F on a bullet which is given by $F = (100 - 0.5 \times 10^5 t)N$. The bullet emerges out with speed 400 m/s. Then find out the impulse exerted till force on bullet becomes zero:
 (1) 0.2 N-s (2) 0.3 N-s (3) 0.1 N-s (4) 0.4 N-s

Ans. (3)

Sol. $F = (100 - 0.5 \times 10^5 t)N$

Given $F = 0$

$$100 - 0.5 \times 10^5 t = 0$$

$$100 = 0.5 \times 10^5 t$$

$$T = 2 \times 10^{-3} \text{ sec}$$

$$I = \int F dt$$

$$I = \int_0^{2 \times 10^{-3}} (100 - 0.5 \times 10^5 t) dt$$

$$I = \left[100t - \frac{10^5 t^2}{2} \right]_0^{2 \times 10^{-3}}$$

$$I = \left[100 \times 2 \times 10^{-3} - \frac{10^5}{4} \times 4 \times 10^{-6} \right]$$

$$I = [2 \times 10^{-1} - 10^{-1}]$$

$$I = 10^{-1} = 0.1 \text{ N-s}$$

13. A proton is projected with velocity $\vec{V} = 2\hat{i}$ in a region where magnetic field $\vec{B} = (\hat{i} + 3\hat{j} + 4\hat{k})\mu\text{T}$ and electric field $\vec{E} = 10\hat{i}\mu\text{V/m}$. Then find out the net acceleration of proton:
 (1) 1400 m/s² (2) 700 m/s² (3) 1000 m/s² (4) 800 m/s²

Ans. (1)

Sol. $\vec{F} = Q\vec{E} + Q(\vec{V} \times \vec{B})$

$$\vec{F} = 1.6 \times 10^{-19} \times 10\hat{i} \times 10^{-6} + 1.6 \times 10^{-19} [(2\hat{i}) \times (\hat{i} + 3\hat{j} + 4\hat{k})] \times 10^{-6}$$

$$\vec{F} = 1.6 \times 10^{-19} [10\hat{i} + 6\hat{k} - 8\hat{j}] \times 10^{-6}$$

$$\vec{F} = 1.6 \times 10^{-19} [10\hat{i} - 8\hat{j} + 6\hat{k}] \times 10^{-6} \text{ N}$$

$$\vec{a} = 1.6 \times 10^{-19} [10\hat{i} - 8\hat{j} + 6\hat{k}] \times 10^{-6} / 1.6 \times 10^{-27} \text{ m/s}^2$$

$$1400 \text{ m/s}^2$$

14. For the system given below, find time period of oscillation?

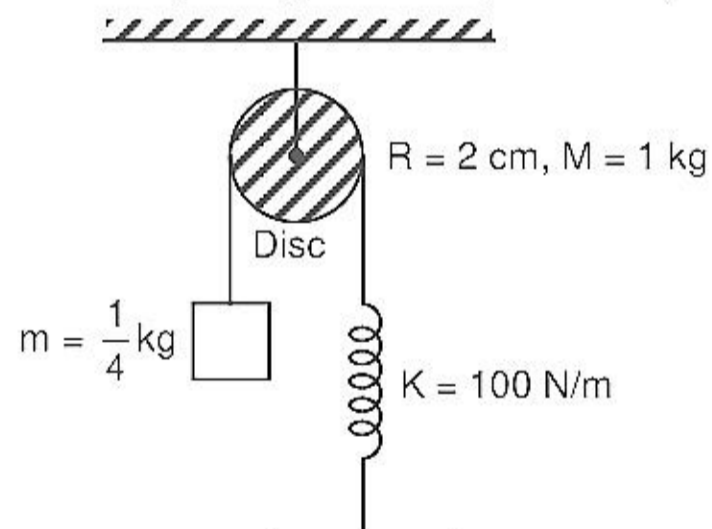

- (1) $\frac{10}{\sqrt{3}}$ (2) $10\sqrt{3}$ (3) $\frac{20}{\sqrt{3}}$ (4) $20\sqrt{3}$

Ans. (3)

Sol. By energy method

$$\frac{1}{2}Kx^2 + \frac{1}{2}mv^2 + \frac{1}{2}I\omega^2 = C$$

$$\frac{1}{2} \cdot K \cdot 2x \cdot \frac{dx}{dt} + \frac{1}{2} \cdot m \cdot 2v \cdot \frac{dv}{dt} + \frac{1}{2} I \cdot \frac{2v}{r^2} \frac{dv}{dt} = 0$$

$$Kxv + \frac{M}{4}va + \frac{M}{2}a \cdot v = 0$$

$$-Kx = \frac{3Ma}{4}$$

$$a = -\frac{4K}{3M} \cdot x = -\omega^2 x$$

$$\omega^2 = \frac{4K}{3M}$$

$$\omega = \sqrt{\frac{4K}{3M}} = \sqrt{\frac{4 \times 100}{3 \times 1}} = \frac{20}{\sqrt{3}} \text{ sec}$$

15. For a telescope, focal length of objective lens is 15 cm and focal length of eye piece is 10 mm. If tube length is 16 cm, then find the magnification:

- (1) 150 (2) 15 (3) 1.5 (4) 10

Ans. (2)

Sol. $m = \frac{f_o}{f_e} = \frac{15}{1} = 15$

16. If sink and source temperature of a refrigerator are 4°C and 15°C respectively. Then efficiency of refrigerator is:

- (1) 0.076 (2) 0.0382 (3) 0.019 (4) 1

Ans. (2)

Sol. $\eta = \left(1 - \frac{T_2}{T_1}\right) = \left(1 - \frac{277}{288}\right) = \frac{11}{288} = 0.0382$

17. In an isothermal process 2 water drops of radius 1 mm are combined to form a bigger drop. Find the energy change in this process if $T = 0.1 \text{ N/m}$

- (1) 1 μJ (2) 0.5 μJ (3) 0.25 μJ (4) 0.75 μJ

Ans. (2)

Sol. $\Delta U = T\Delta A$

By volume conservation

$$2 \times \frac{4}{3} \pi (1 \text{ mm})^3 = \frac{4}{3} \pi R^3 \Rightarrow R = 2^{1/3} \text{ mm}$$

$$\begin{aligned} \Delta U &= 0.1 \text{ N/m} \times 4\pi [2 \times (1 \text{ mm})^2 - (2^{1/3} \text{ mm})^2] \\ &= 0.4 \pi \times [2 - 2^{2/3}] \times 10^{-6} \text{ J} \\ &= 0.4 \pi \times 0.41 \times 10^{-6} \text{ J} = 0.52 \mu\text{J} \end{aligned}$$

18. The given transistor operates in saturation region then what should the be value of V_{BB} : ($R_{out} = 200 \Omega$, $R_{in} = 100 \text{ K}\Omega$, $V_{CC} = 3 \text{ volt}$, $V_{BE} = 0.7 \text{ volt}$, $V_{CE} = 0$, $\beta = 200$)

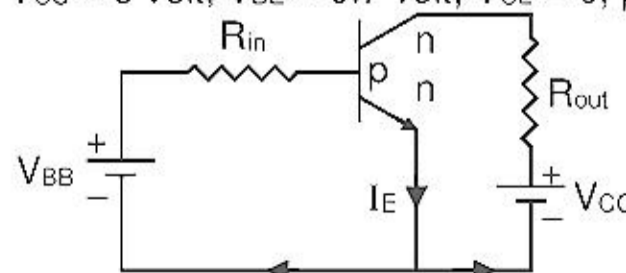

- (1) 4.1 volt (2) 7.5 volt (3) 8.2 volt (4) 6.8 volt

Ans. (3)

Sol. $V_{CE} = V_{CC} - I_C R_O \Rightarrow 0 = 3 - I_C \times 200$

$$I_C = \frac{3}{200} = 15 \text{ mA}$$

$$\beta = 200 = \frac{I_C}{I_B} \Rightarrow I_B = \frac{I_C}{\beta} = \frac{15 \text{ mA}}{200} = 75 \mu\text{A}$$

$$V_{BE} = V_{BB} - I_B R_{in}$$

$$V_{BB} = 0.7 + 75 \times 10^{-6} \times 100 \times 10^3$$

$$= 0.7 + 7.5 = 8.2 \text{ volt}$$

- 19.** Body A of mass 4 m moving with speed u collides with another body B of mass 2 m at rest the collision is head on and elastic in nature. After the collision the fraction of energy lost by colliding body A is :
 चाल u से गतिमान 4 m द्रव्यमान का कोई पिण्ड A विराम में स्थित 2 m द्रव्यमान के किसी पिण्ड B से आमने सामने सीधे प्रत्यास्थ प्रकृति का संघट्ट करता है। संघट्ट के पश्चात् संघट्ट करने वाले पिण्ड A की क्षयित ऊर्जा का भाग है:

[XI_Centre of Mass]

- (1) $\frac{5}{9}$ (2) $\frac{1}{9}$ (3) $\frac{8}{9}$ (4) $\frac{4}{9}$

Ans. (3)

Sol. Energy transferred to B initial energy of B = zero

Final velocity of

$$V_B = \left(\frac{M_2 - M_1}{M_1 + M_2} \right) u_2 + \frac{2M_1 u_1}{M_1 + M_2}$$

$$M_1 = 4M \quad u_1 = u$$

$$M_2 = 2M \quad u_2 = 0$$

$$V_B = \frac{2(4M)u}{6M} = \frac{4}{3}u$$

$$\frac{\frac{1}{2} M_2 V_B^2}{\frac{1}{2} M_1 u_1^2} = \frac{\frac{1}{2} 2M \left(\frac{4}{3} \right)^2 u^2}{\frac{1}{2} 4M u^2}$$

$$\text{Fraction of energy lost} = \frac{8}{9}$$

- 20.** A disc of radius 20 cm and mass half kg is rolling on an inclined plane. Find out friction force so that disc performs pure rolling.

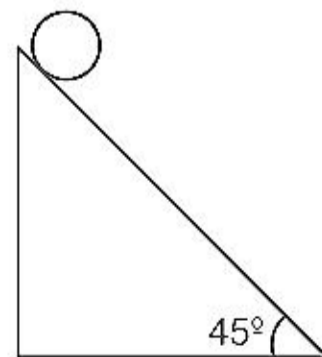

- (1) $\frac{5\sqrt{2}}{3} \text{ N}$ (2) $\frac{5}{3\sqrt{2}} \text{ N}$ (3) $\frac{5}{\sqrt{2}} \text{ N}$ (4) $\frac{5}{2\sqrt{3}} \text{ N}$

Ans. (2)

Sol.

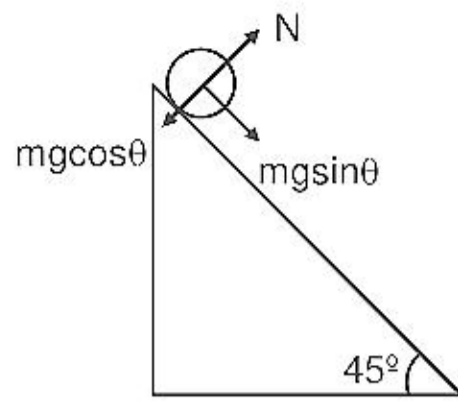

$$Mg \sin \theta - f = ma_{cm} \quad \dots(i)$$

$$\tau_{cm} = I_{cm} \cdot \alpha$$

$$fR = \frac{MR^2}{2} \left(\frac{a_{cm}}{R} \right)$$

$$f = \frac{Ma_{cm}}{2}$$

$$\text{or } a_{cm} = \frac{2f}{M}$$

$$\text{so } mg \sin \theta - f = M \left(\frac{2f}{M} \right)$$

$$f = \frac{mg \sin \theta}{3}$$

$$f = \frac{1}{2} \times \frac{10}{3} \times \frac{1}{\sqrt{2}} = \frac{5}{3\sqrt{2}} \text{ Newton}$$

21. If temperature of Sun = 6000K, radius of Sun is 7.2×10^5 Km, radius of Earth = 6000 Km & distance between earth and Sun = 15×10^7 Km. Find intensity of light on Earth.

- (1) 19.2×10^{16} (2) 12.2×10^{16} (3) 18.3×10^{16} (4) 9.2×10^{16}

Ans. (1)

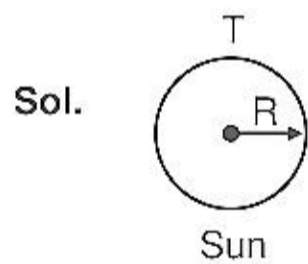

$$\text{Total energy emitted by Sun} = \sigma T^4 \times 4\pi R^2$$

$$\text{Energy received by earth} = \frac{\sigma T^4 4\pi R_s^2}{4\pi d^2} \times \pi (R_e)^2$$

$$= \frac{\sigma T^4 R_s^2}{d^2} \times \pi R_e^2$$

$$= \frac{5.67 \times 10^{-8} \times (6000)^4 \times (7.2 \times 10^8)^2 \times 3.14 \times (6000 \times 10^3)^2}{(1.5 \times 10^{11})^2}$$

$$= \frac{5.67 \times 36 \times 36 \times 7.2 \times 7.2 \times 36 \times 3.14}{2.25} \times 10^{10} = 19.2 \times 10^{16}$$

22. If radius of O_2 molecule = 40 \AA , $T = 27^\circ\text{C}$ and $P = 1 \text{ atm}$. Find the time of relaxation.

- (1) 10^{-10} sec (2) 10^{-12} sec (3) 10^{-14} sec (4) 10^{-8} sec

Ans. (2)

Sol. $\tau = \frac{\lambda}{V_{rms}} = \frac{1}{\sqrt{2\pi n d^2}} \frac{\sqrt{m_0}}{\sqrt{3RT}}$

Now $n = \frac{N}{V} = \frac{\mu N_a}{V}$

$PV = \mu RT$

$\frac{\mu}{V} = \frac{P}{RT}$

So $n = \frac{P}{RT} \times N_a$

$\tau = \frac{\sqrt{m_0} RT}{\sqrt{2\pi P N_a d^2} \sqrt{3RT}}$

$\tau = \frac{\sqrt{m_0} RT}{\sqrt{6 \times 3.14 \times 10^5 \times 6.02 \times 10^{23} \times (40 \times 10^{-10})^2}}$

$= \frac{\sqrt{32 \times 3 \times 8.3 \times 10^{-1}}}{\sqrt{6 \times 3.14 \times 10^5 \times 6.02 \times 10^{23} \times 16 \times 10^{-18}}}$

$= \frac{\sqrt{96 \times 0.83}}{\sqrt{6 \times 3.14 \times 6.02 \times 16 \times 10^{10}}}$

$= \frac{4 \times \sqrt{0.83}}{3.14 \times 6.02 \times 16 \times 10^{10}}$

$= \frac{0.9}{3.14 \times 6 \times 4 \times 10^{10}}$

$= 0.01 \times 10^{-10}$

$= 10^{-12} \text{ sec}$

23. Frequency of L-C circuit is f_1 . If a resistance R is also added to it, the frequency becomes f_2 . The ratio of $\frac{f_2}{f_1}$ will be:

- (1) $\sqrt{1 + \frac{R^2 C}{4L}}$ (2) $\sqrt{1 - \frac{R^2 C}{4L}}$ (3) $\sqrt{1 + \frac{R^2 C}{L}}$ (4) $\sqrt{1 - \frac{R^2 C}{L}}$

Ans. (2)

Sol. $\omega_1 = \frac{1}{\sqrt{LC}}$

$\omega_2 = \sqrt{\left(\frac{1}{\sqrt{LC}}\right)^2 - \left(\frac{R}{2L}\right)^2}$

$\frac{\omega_2}{\omega_1} = \frac{\sqrt{\frac{1}{LC} - \frac{R^2}{4L^2}}}{\frac{1}{\sqrt{LC}}} = \sqrt{1 - \frac{R^2 C}{4L}}$

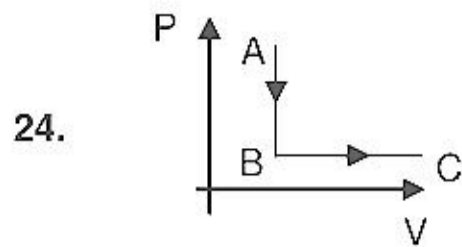

If one mole of an ideal gas goes through the process $A \rightarrow B$ and $B \rightarrow C$. Given that $T_A = 400$ K, and $T_C = 400$ K. If $\frac{P_A}{P_B} = \frac{1}{5}$, then find the heat supplied to the gas.

- (1) 2059.2 J (2) 3659.2 J (3) 2225.2 J (4) 2659.2 J

Ans. (4)

Sol. $\Delta Q = nC_V\Delta T + nC_P\Delta T$
 $= n\Delta T (C_P - C_V)$
 $= 1 \times 8.31 \times \left(400 - \frac{400}{5}\right)$
 $= 8.31 \times \frac{400}{5} \times 4$
 $= 2659.2$ J

25. A capacitor of capacitance 9nF having dielectric slab of $\epsilon_r = 2.4$ dielectric strength 20 MV/m and P.D. = 20V calculate area of plates.

- (1) $2.1 \times 10^{-4} \text{ m}^2$ (2*) $4.2 \times 10^{-4} \text{ m}^2$ (3) $1.4 \times 10^{-4} \text{ m}^2$ (4) $2.4 \times 10^{-4} \text{ m}^2$

Ans. (2)

Sol. $C = 9\text{nF}$, $\epsilon_r = 2.4$, $V = 20$ volt
 Dielectric strength = 20MV/m
 Let separation between plates = d

$$E = \frac{V}{d}$$

$$20 \times 10^6 = \frac{20}{d}$$

$$d = 10^{-6} \text{ m}$$

Now,

$$C = \frac{\epsilon_0 A \epsilon_r}{d}$$

$$9 \times 10^{-9} = \frac{8.85 \times 10^{-12} \times A \times 2.4}{10^{-6}}$$

$$A = \frac{9 \times 10^{-9} \times 10^6}{8.85 \times 2.4 \times 10^{-12}}$$

$$A = 0.42 \times 10^{-3}$$

$$A = 4.2 \times 10^{-4} \text{ m}^2$$

26. In figure two parallel infinitely long current carrying wires are shown. If resultant magnetic field at point A is zero. Then determine current I.

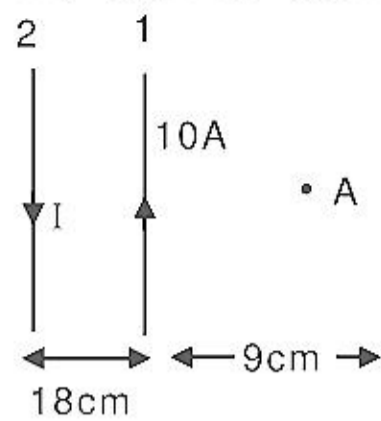

- (1) 50 A (2) 15 A (3) 30 A (4) 25 A

Ans. (3)

Sol.

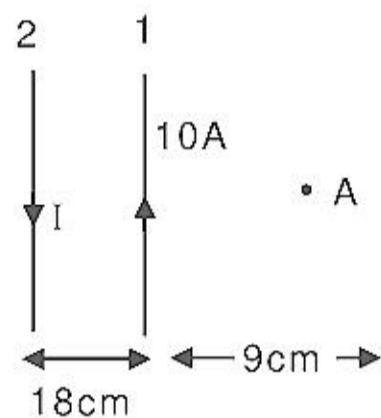

at A $B_1 + B_2 = 0$

$$\frac{\mu_0 i_1}{2\pi r_1} = \frac{\mu_0 i_2}{2\pi r_2}$$

$$\frac{i_1}{27} = \frac{10}{9}$$

$$I = 30A$$

27. A liquid enter at point A₁ with speed 3.5 m/s and leaves at point A₂. Then find out the height attained by the liquid above point A₂.

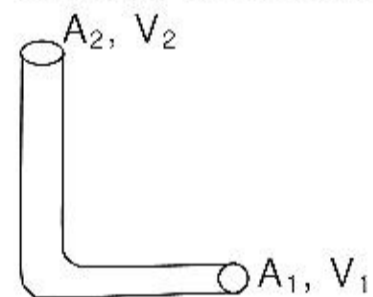

- (1*) 61.25 cm (2) 51.25 cm (3) 41.25 cm (4) 71.25 cm

Ans. (1)

Sol.

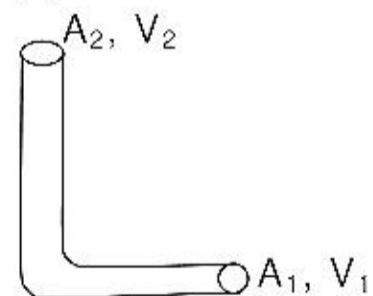

$$A_1 V_1 = A_2 V_2$$

$$A_1 = A_2 \quad \Rightarrow \quad V_1 = V_2 = 3.5 \text{ m/s}$$

Maximum height achieved

Using Bernoulli theorem

$$P_{\text{atm}} + \frac{1}{2}\rho(3.5)^2 + \rho g \cdot 0 = P_{\text{atm}} + \frac{1}{2}(\rho)(0)^2 + \rho g h$$

$$H = \frac{v^2}{2g} = \frac{3.5 \times 3.5}{20} = \frac{12.25}{20} = 0.6125 \text{ m} = 61.25 \text{ cm}$$

28. If potential energy is given by $U = \frac{a}{r^2} - \frac{b}{r}$. Then find out maximum force. (given $a = 2$, $b = 4$)

(1) $-\frac{16}{27} \text{ N}$ (2) $-\frac{32}{27} \text{ N}$ (3) $+\frac{32}{27} \text{ N}$ (4) $+\frac{16}{27} \text{ N}$

Ans. (1)

Sol. $F = -\frac{du}{dr} = -\left[-\frac{2a}{r^3} + \frac{b}{r^2}\right]$

$$= \frac{2a}{r^3} - \frac{b}{r^2}$$

$$\frac{dF}{dr} = -\frac{6a}{r^4} + \frac{2b}{r^3} = 0$$

$$\Rightarrow \frac{6a}{r} = 2b$$

$$\Rightarrow F_{\max} = \frac{2 \times 2}{(3/2)^3} - \frac{4}{(3/2)^2}$$

$$= \frac{4 \times 8}{27} - \frac{4 \times 4}{9} = \frac{32 - 16 \times 3}{27} = -\frac{16}{27}$$

29. Find γ for the mixture of 11 gm CO_2 and 14 gm N_2 ?

(1) $\gamma_{\text{mix}} = \frac{7}{5}$ (2) $\gamma_{\text{mix}} = \frac{10}{5}$ (3) $\gamma_{\text{mix}} = \frac{11}{8}$ (4) $\gamma_{\text{mix}} = \frac{4}{3}$

Ans. (1)

30. The De-broglie wavelength of electron in 3rd orbit of He^{+1} ion is approximately

(1) $2A^\circ$ (2) $3A^\circ$ (3) $4A^\circ$ (4) $5A^\circ$

Ans. (4)

Sol. $2\pi r = n\lambda$

$$\lambda = \frac{2\pi r}{n} = \frac{2\pi \times (0.529A^\circ) \frac{n^2}{Z}}{n}$$

$$\lambda = (0.529A^\circ) \frac{n^2}{Z} = 2\pi \times (0.529A^\circ) \frac{3}{2}$$

$$\lambda = 3\pi \times 0.529A^\circ \approx 5A^\circ$$

31. Find ratio of acceleration and angular acceleration of com? If for the above diagram $m = 2\text{kg}$ and $r = 10 \text{ cm}$

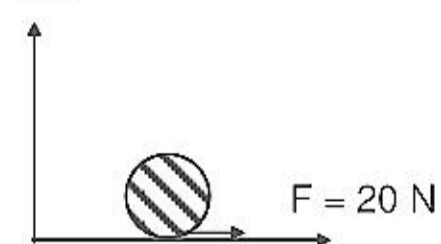

(1) $\frac{1}{5}$ (2) $\frac{1}{10}$ (3) $\frac{1}{15}$ (4) $\frac{1}{20}$

Ans. (4)

Sol. $a = \frac{F}{m} = \frac{20}{2} = 10$

$\tau = I \propto$

$20 \times \frac{1}{10} = \frac{1}{z} \times 2 \times (0.1)^2 \times \propto$

$\propto = 200$

$\frac{a}{\propto} = \frac{10}{200} = \frac{1}{20}$ **Ans.**

32. Energy of electron (in eV) in 2nd orbit of He⁺ ion ?

- (1) - 10.6 eV (2) - 13.6 eV (3) - 15.6 eV (4) - 25.6 eV

Ans. (3)

Sol. $E = -13.6 \text{ eV} \frac{z^2}{n^2}$

$= -13.6 \text{ eV} \frac{z^2}{z^2} = -13.6 \text{ eV}$

33. A toroid having average diameter 2.5 m, number A turns 400, current = 2A and magnetic field has 10 T what will be induced magnetic field (in amp/m)

- (1) $\frac{10^5}{4\pi}$ (2) $\frac{10^8}{4\pi}$ (3) $\frac{10^8}{2\pi}$ (4) $\frac{10^2}{2\pi}$

Ans. (2)

Sol. $H =$

$B = \mu_0 (H + I)$

$10 = \mu_0 \left(\frac{N}{2\pi r} \times i + I \right)$

$I = \frac{10}{4\pi \times 10^{-7}} - \frac{400 \times 2 \times 2}{2\pi \times 2.5} = \frac{10^8}{4\pi}$

34. Find magnification for lens.

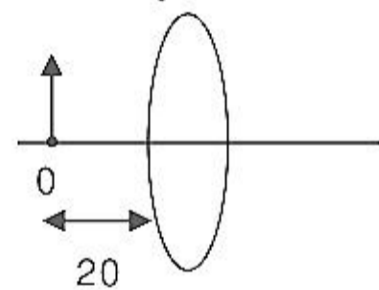

- (1) 2 (2) 5 (3) 7 (4) 12

Ans. (2)

Sol. $u = -20$

$f = 25$

$\frac{1}{v} - \frac{1}{20} = \frac{1}{25}$

$\frac{1}{v} = \frac{1}{25} + \frac{1}{20} = \frac{4-5}{100}$

$v = -100$

$M = \frac{v}{u} = \frac{-100}{-20} = 5$ **Ans.**

35. Calculate radiation power for sphere whose temperature is 227°C and radius 2 m and emissivity 0.8.
 (1) 1425W (2) 1500 W (3) 1255 W (4) 1575W

Ans. (1)

Sol. $P = \sigma A e T^4$

36. Determine efficiency of carnot cycle if in adiabatic expansion volume 3 times of initial value and $r = 1.5$

- (1) $1 - \frac{1}{\sqrt{2}}$ (2) $1 - \frac{1}{\sqrt{3}}$ (3) $1 + \frac{1}{\sqrt{2}}$ (4) $1 + \frac{1}{\sqrt{3}}$

Ans. (2)

Sol. $T_1 V_1^{r-1} = T_2 V_2^{r-1}$

$$\frac{T_2}{T_1} = \left(\frac{V_1}{V_2}\right)^{r-1} = \left(\frac{1}{3}\right)^{1.5-1} = \frac{1}{\sqrt{3}} \Rightarrow \eta = 1 - \frac{T_2}{T_1} = 1 - \frac{1}{\sqrt{3}} \text{ Ans.}$$

37. Maximum amplitude of SHM so block A will not slip on block B, $K = 100 \text{ N/m}$

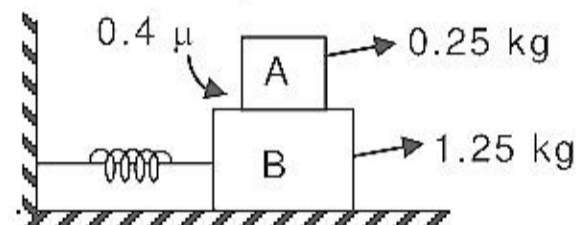

- (1) 2 (2) 4 (3) 6 (4) 8

Ans. (3)

Sol. $F = mw^2A = \mu mg$

$$A = \frac{\mu g}{\omega^2}, \quad \omega = \sqrt{\frac{K}{m}}$$

$$\omega = \sqrt{\frac{100}{1.5}}$$

$$A = 6 \text{ cm}$$

38. The temperature of food material in refrigerator is 4°C and temperature of environment is 15°C . If carnot cycle is used in its working gas, then find its carnot efficiency.

- (1) 0.038 (2) 0.028 (3) 0.053 (4) 0.072

Ans. (1)

Sol. $\eta = 1 - \frac{T_2}{T_1}$

$$= 1 - \frac{273 + 4}{273 + 15}$$

$$= 0.038$$

39. The graph between velocity and position for a damped oscillation will be :-

- (1) straight line (2) Circle (3) Ellipse (4) Spiral

Ans. (4)

Sol. In damped oscillation, the amplitude will decrease so the graph of V v/s x will be :-

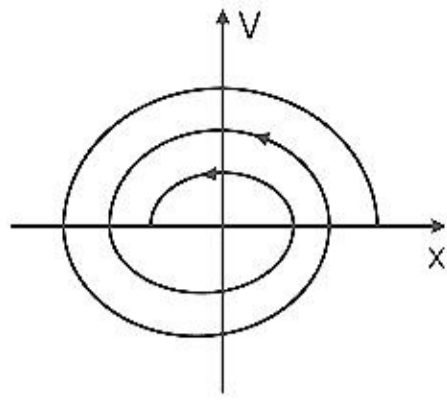

40. **Assertion:** In U_{235} fission reaction neutrons are required to be slowed down.

Reason: The probability of capture of slow moving neutrons is high for U_{235} .

- (1) If both assertion and reason are true and reason is the correct explanation of assertion.
- (2) If both assertion and reason are true but reason is not the correct explanation of assertion.
- (3) If assertion is true but reason is false.
- (4) If both assertion and reason are false.

Ans. (1)

41. **Assertion:** P v/s $\frac{1}{V}$ graph is straight line for adiabatic process

Reason: $PV = \text{constant}$ for adiabatic process

- (1) If both assertion and reason are true and reason is the correct explanation of assertion.
- (2) If both assertion and reason are true but reason is not the correct explanation of assertion.
- (3) If assertion is true but reason is false.
- (4) If both assertion and reason are false.

Ans. (4)

Sol. P v/s $\frac{1}{V^{\gamma}}$ is straight line process equation for adiabatic is $PV^{\gamma} = \text{constant}$.

42. **Assertion:** Electron moving perpendicular to \vec{B} will perform circular motion

Reason: Force by magnetic field is perpendicular to velocity

- (1) If both assertion and reason are true and reason is the correct explanation of assertion.
- (2) If both assertion and reason are true but reason is not the correct explanation of assertion.
- (3) If assertion is true but reason is false.
- (4) If both assertion and reason are false.

Ans. (2)

Sol. If $\vec{F} \perp \vec{V}$ at all instants then motion will be circular

43. **Assertion:** A glass ball is dropped on concrete floor can easily get broken compared if it is dropped on wooden floor

Reason: On concrete floor glass ball will take less time to come to rest

- (1) If both assertion and reason are true and reason is the correct explanation of assertion.
- (2) If both assertion and reason are true but reason is not the correct explanation of assertion.
- (3) If assertion is true but reason is false.
- (4) If both assertion and reason are false.

Ans. (1)

Sol. Force exerted by concrete floor is more because change in momentum is fast.

44. **Assertion:** Distance between position of bright and dark fringe remain same in YDSE

Reason: fringe width $\beta = \frac{\lambda D}{d}$

- (1) If both assertion and reason are true and reason is the correct explanation of assertion.
- (2) If both assertion and reason are true but reason is not the correct explanation of assertion.
- (3) If assertion is true but reason is false.
- (4) If both assertion and reason are false.

Ans. (1)

Sol. Distance between consecutive fringe is independent of its number.

45. **Assertion:** Paramagnetic substances get poorly attracted in magnetic field.

Reason: Because magnetic dipoles are aligned along external magnetic field weakly

- (1) If both assertion and reason are true and reason is the correct explanation of assertion.
- (2) If both assertion and reason are true but reason is not the correct explanation of assertion.
- (3) If assertion is true but reason is false.
- (4) If both assertion and reason are false.

Ans. (1)

46. **Assertion:** Heavy water is used to slow down neutron in nuclear reactor

Reason: It does not react with slow speed neutron and mass of deuterium is comparable to the neutron

- (1) If both assertion and reason are true and reason is the correct explanation of assertion.
- (2) If both assertion and reason are true but reason is not the correct explanation of assertion.
- (3) If assertion is true but reason is false.
- (4) If both assertion and reason are false

Ans. (1)

47. **Assertion:** Collision between two billiard's ball are inelastic

Reason: Momentum remains conserve during the collision

- (1) If both assertion and reason are true and reason is the correct explanation of assertion.
- (2) If both assertion and reason are true but reason is not the correct explanation of assertion.
- (3) If assertion is true but reason is false.
- (4) If both assertion and reason are false.

Ans. (2)

Sol. billiard's ball are not perfect elastic body. Some part of initial kinetic energy is lost in form of deformation energy and momentum remain conserved during every collision.

48. **Assertion :** Rayleigh scattering can be considered as elastic collisions of photons with massive particles.

Reason: In Rayleigh scattering, the energy of incident and scattered is same

- (1) If both assertion and reason are true and reason is the correct explanation of assertion.
- (2) If both assertion and reason are true but reason is not the correct explanation of assertion.
- (3) If assertion is true but reason is false.
- (4) If both assertion and reason are false.

Ans. (1)

Sol. In Rayleigh scattering, when a photon (of momentum P) collide with a very massive particles (of mass m) (distant particles,..... etc.) then the momentum transferred will be P or 2P

so energy transferred is $\frac{P^2}{2m}$ or $\frac{(P^2)}{2m}$ which will be very small.

49. **Assertion:** FM broadcast is better than AM broadcast.
Reason: Noise change is maximum in amplitude of AM waves.
 (1) If both assertion and reason are true and reason is the correct explanation of assertion.
 (2) If both assertion and reason are true but reason is not the correct explanation of assertion.
 (3) If assertion is true but reason is false.
 (4) If both assertion and reason are false.
Ans. (1)
Sol. FM broadcast is better than AM broadcast because in AM broadcast electric signals superimpose with main signal.
50. **Assertion:** In adiabatic process work is independent of path.
Reason: In adiabatic process work done is equal to negative of change in internal energy.
 (1) If both assertion and reason are true and reason is the correct explanation of assertion.
 (2) If both assertion and reason are true but reason is not the correct explanation of assertion.
 (3) If assertion is true but reason is false.
 (4) If both assertion and reason are false.
Ans. (1)
Sol. For adiabatic process $Q = 0 = \Delta U + W$
 $W = -\Delta U$
51. **Assertion:** Water drops take spherical shape when falling freely.
Reason: Water has minimum surface tension among all liquids.
 (1) If both assertion and reason are true and reason is the correct explanation of assertion.
 (2) If both assertion and reason are true but reason is not the correct explanation of assertion.
 (3) If assertion is true but reason is false.
 (4) If both assertion and reason are false.
Ans. (4)
Sol. Water drops take oval shape when falling freely. Surface tension of water is not minimum among all liquids.
52. **Assertion :** In ionospheric reflection, phase change does not occurs with the light wave.
Reason : The ionosphere reflection is similar to the total internal reflection is similar to the total internal reflection in miraj
 (1) If both assertion and reason are true and reason is the correct explanation of assertion.
 (2) If both assertion and reason are true but reason is not the correct explanation of assertion.
 (3) If assertion is true but reason is false.
 (4) If both assertion and reason are false.
Ans. (1)
Sol. In TIR, the reflection occurs from a rarer medium, so the reflected ray does not get inverted in phase.
53. **Assertion :** There is no loss in energy in elastic collision
Reason : Linear momentum is conserved in elastic collision
 (1) If both assertion and reason are true and reason is the correct explanation of assertion.
 (2) If both assertion and reason are true but reason is not the correct explanation of assertion.
 (3) If assertion is true but reason is false.
 (4) If both assertion and reason are false.
Ans. (2)
54. **Assertion :** In both radio activity and photoelectric effect electrons may be ejected.
Reason : In photoelectric effect and radio activity emission occurs only of unstable elements.
 (1) If both assertion and reason are true and reason is the correct explanation of assertion.
 (2) If both assertion and reason are true but reason is not the correct explanation of assertion.
 (3) If assertion is true but reason is false.
 (4) If both assertion and reason are false.
Sol. (3)

PART - B (CHEMISTRY)

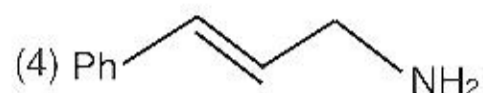
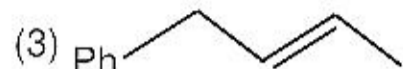
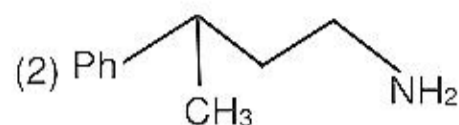
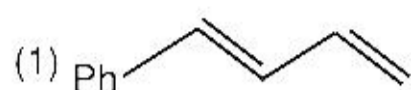
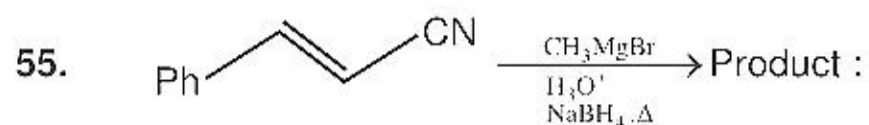

Ans. (2)

56. Match the following column

Polymer

- (i) Buna-S
- (ii) ethylene glycol
- (iii) elastomer

Monomer

- (P) Styrene
- (Q) terylene
- (R) chloroprene

Correct set of answer :

(1) (i) – (P) (ii) – (Q) (iii) – (R)

(2) (i) – (R) (ii) – (P) (iii) – (Q)

(3) (i) – (Q) (ii) – (R) (iii) – (P)

(4) (i) – (P) (ii) – (R) (iii) – (Q)

Ans. (1)

57. Find the end product of reaction

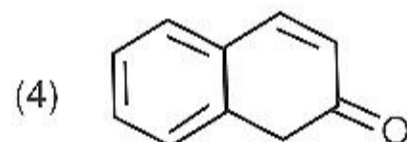
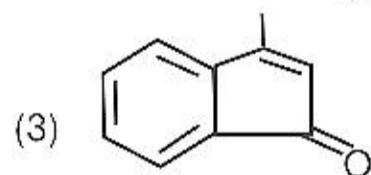
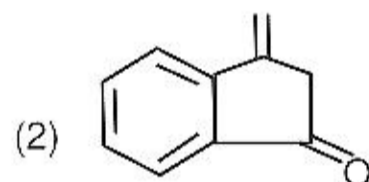
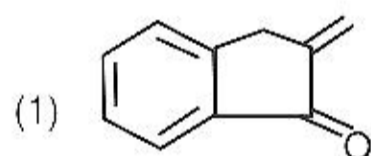
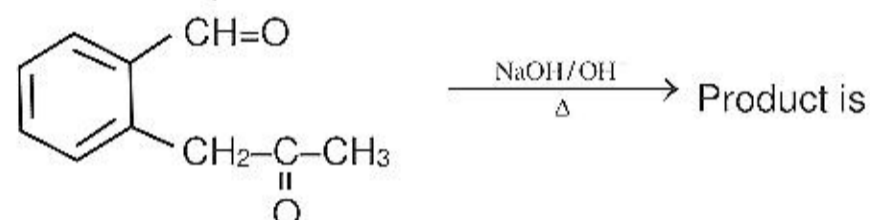

Ans. (4)

58. Compare stability of free radicals

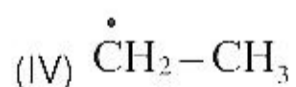
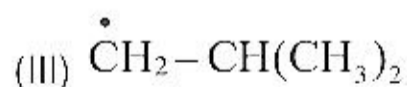
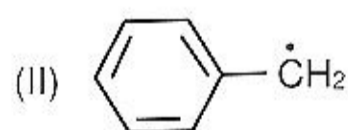
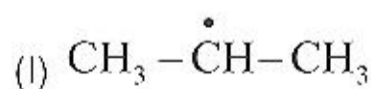

(1) II > I > III > IV

(2) II > I > IV > III

(3) I > II > III > IV

(4) IV > III > I > II

Ans. (2)

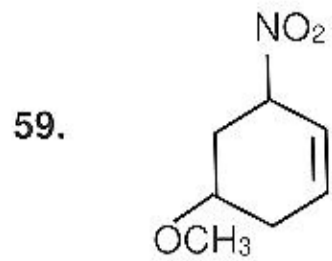

Write IUPAC name of following compound

(1) 4-Methoxy-6-Nitro cyclohexene

(2) 5-Methoxy-3-Nitro cyclohexene

(3) 3-Nitro-1-Methoxy cyclohex-4-ene

(4) 3-Nitro-5-Methoxy cyclohexene

Ans. (2)



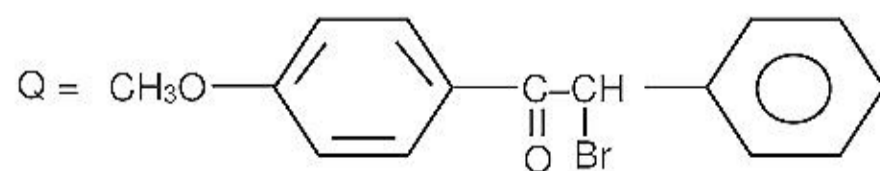
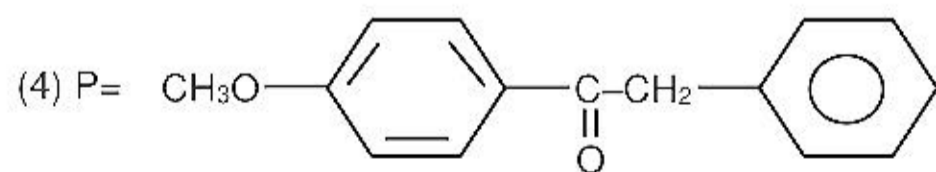
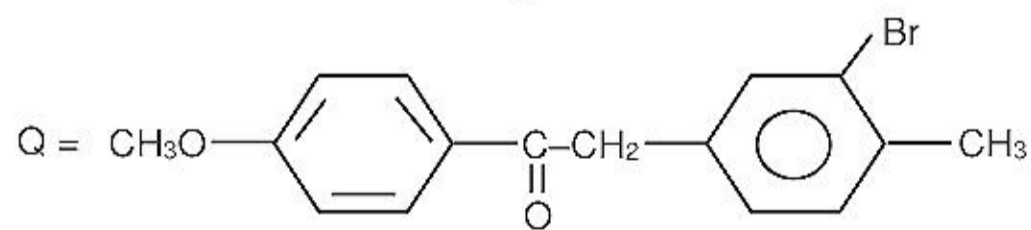
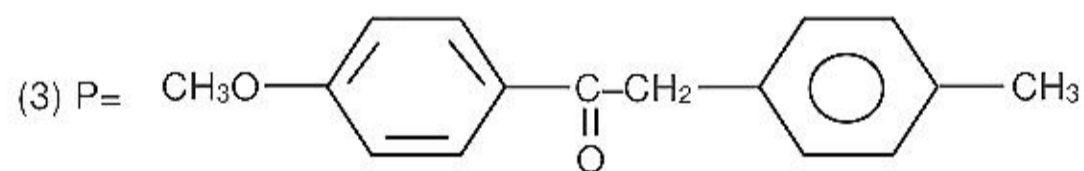
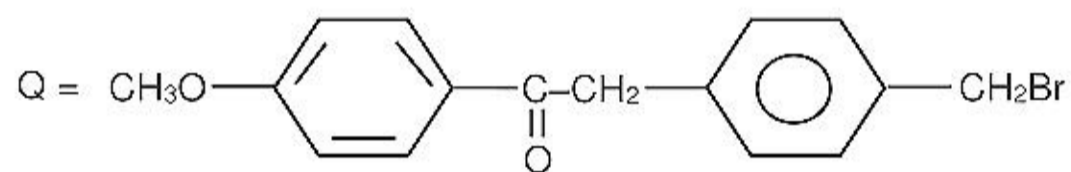
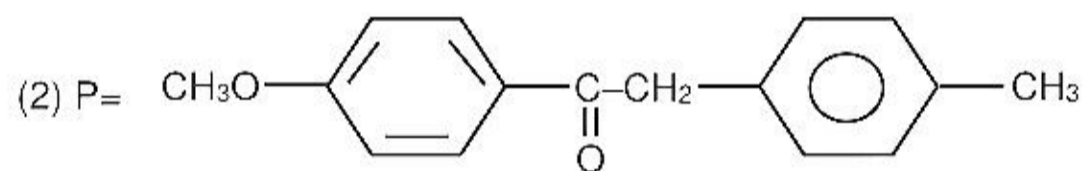
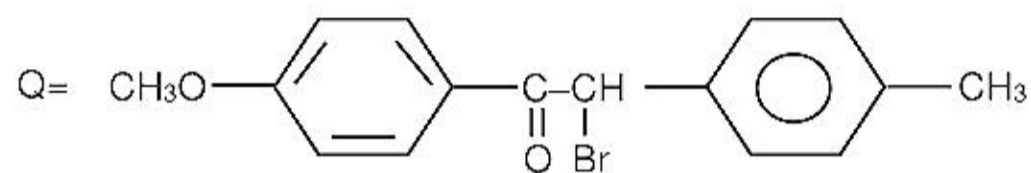
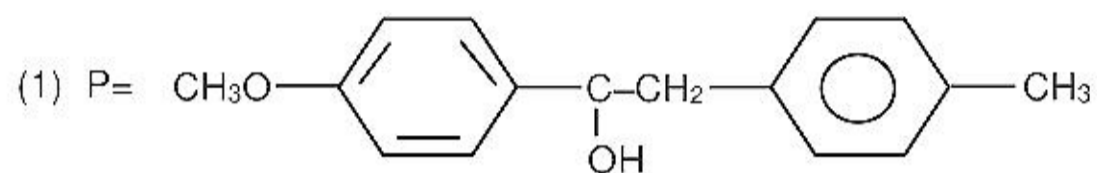

Identify structure of 'P' and 'Q'



Ans. (3)

61. Which is incorrect for paper chromatography
 (1) It is a part of partition chromatography
 (2) It is a stationary phase
 (3) R_f value decrease when rate of adsorption increase
 (4) None of these

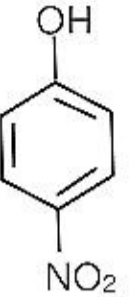
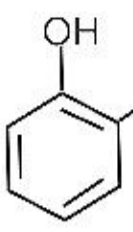
Ans. (2)

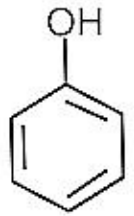
62. Order of acidic nature (a) , (b) , (c)  and (d) 
- (1) $a > c > d > b$ (2) $a > b > d > c$ (3) $a > b > c > d$ (4) $d > c > b > a$

Ans. (2)

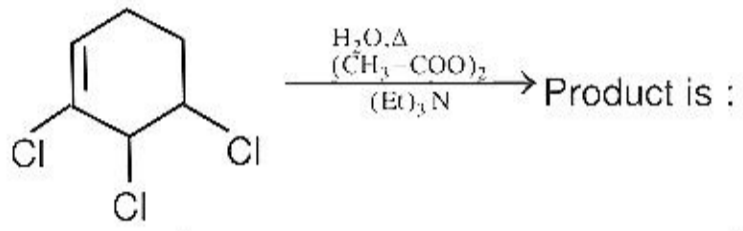
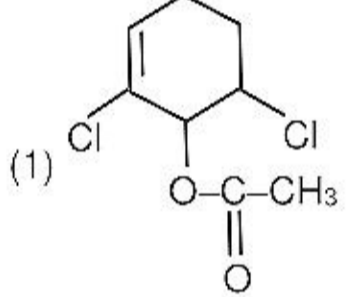
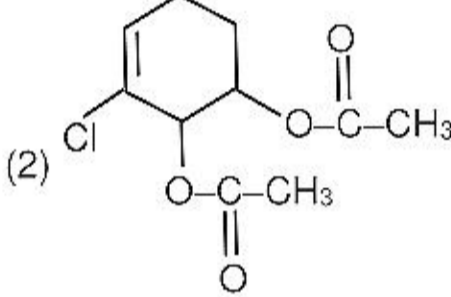
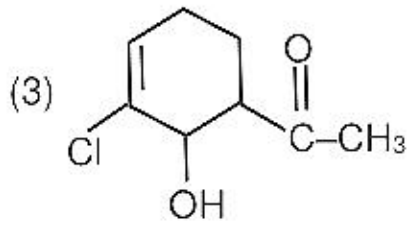
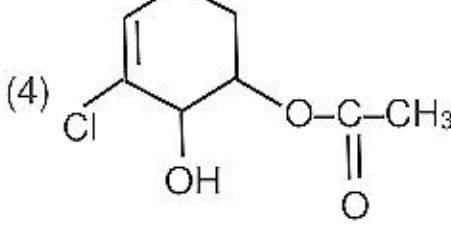
63.  Product is :
- (1)  (2) 
 (3)  (4) 

Ans. (1)

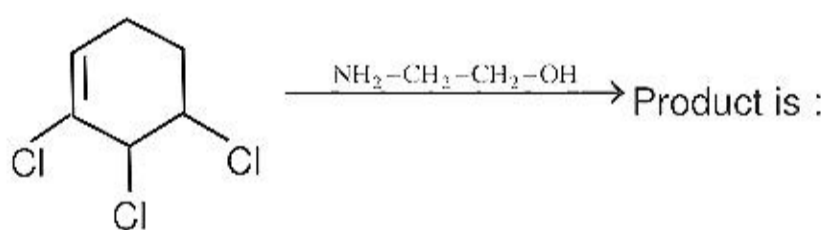
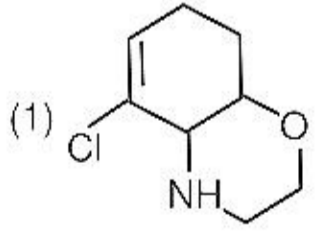
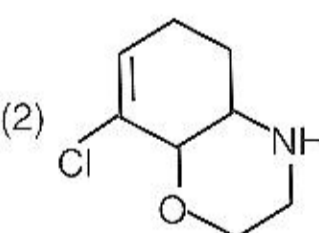
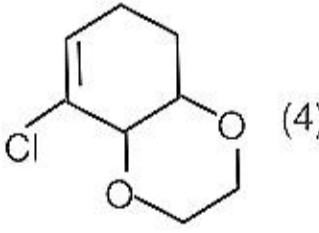
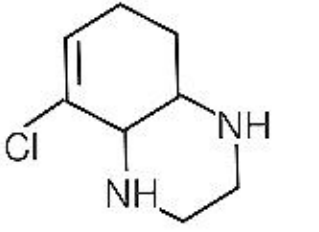
64.  Product is :
- (1)  (2) 
 (3)  (4) 

Ans. (1)

65. **Assertion** : Glucose does not gives 2,4-DNP test
Reason : Glucose exists in cyclic hemiacetal form

Ans. (1)

66. **Assertion** : Phenol reacts with CH_3I in presence of NaOH to form methoxybenzene.
Reason : Phenoxide is better nucleophile than phenol

Ans. (1)

67. **Assertion** : Bromoacetic acid reacts with conc. NaOH to form α -ethoxy acetic acid

Reason : It is S_N1 mechanism

Ans. (4)

68. **Assertion** : $(C_2H_5)_3N$ is less basic than trimethylamine $(CH_3)_3N$

Reason : Due to hyperconjugation of C_2H_5 is less than methyl.

Ans. (3)

69. Which of the following number of lone pair at central atom zero

XeO_3 , XeO_2F_2 , XeO_4 , XeO_3F_2 , Ba_2XeF_4

(1) 2 (2) 3 (3) 4 (4) Zero

Ans. (1)

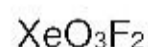

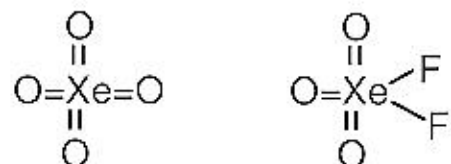
Sol.  \Rightarrow both does not have lone pair of electrons

70. Which of the following does not give ppt with CrO_4^{-2}

(1) Ca^{+2} (2) Sr^{+2} (3) Pb^{+2} (4) Ba^{+2}

Ans. (1)

Sol. In vth group cation Ca^{+2} does not give ppt with CrO_4^{-2} has its solubility is high.

Order of $K_{sp} \Rightarrow BaCrO_4 < SrCrO_4 < CaCrO_4$

71. Calculate emf of cell at $25^\circ C$

Cell notation



If value of E_{cell}^0 is 4 volt (Given $\frac{RT}{F}$ in 10 = 0.06)

(1) 3.94 Volt (2) 4.06 Volt (3) 2.03 Volt (4) 8.18 Volt

Ans. (1)

Sol.
$$E = E^0 - \frac{0.059}{2} \log \frac{10^{-4}}{10^{-2}}$$

$$E = 4 - 0.03 \log 10^{-2}$$
$$4 - 0.06 = 3.94$$

72. Find out time period of 1st order reaction. When reaction complete $\frac{2}{3}$ rd. If the value of rate constant is

4.3×10^{-4}

(1) 0.0025×10^3 sec (2) 0.25×10^3 sec (3) 0.025×10^3 sec (4) 2.5×10^3 sec

Ans. (4)

Sol. $R \rightarrow P$

a

$$a - x \quad x = \frac{2}{3}a$$

$$a - \frac{2}{3}a = \frac{1}{3}a$$

$$t = \frac{2.3}{4.3 \times 10^{-4}} \log \frac{a}{\frac{a}{3}}$$

$$= 2.5 \times 10^3$$

73. The vapour pressure of pure CHCl_3 and CH_2Cl_2 are 200 and 41.5 atm respectively. The weight of CHCl_3 and CH_2Cl_2 are respectively 11.9 g and 17 gm. The vapour pressure of solution will be

- (1) 80.5 (2) 79.5 (3) 94.3 (4) 105.5

Ans. (3)

Sol. $P_{\text{CHCl}_3}^0 = 200 \text{ atm}$ $P_{\text{CH}_2\text{Cl}_2}^0 = 41.5 \text{ atm}$

$$n = \frac{11.9}{119} \qquad n = \frac{17}{85}$$

$$= .1 \qquad = .2$$

$$P_T = P_A^0 X_A + P_B^0 X_B$$

$$= 200 \times \frac{0.1}{.3} + \frac{41.5 \times 0.2}{.3}$$

$$= 94.33$$

74. If $n = 2$ for He^+ ion than find out the wave length

- (1) 3.33 Å (2) 6.42 Å (3) 1.47 Å (4) 2.37 Å

Ans. (1)

Sol. $2\pi r = n\lambda$

$$2\pi \times 0.529 \times \frac{n^2}{Z} = n\lambda$$

$$\lambda = \frac{2\pi \times 0.529 \times n^2}{n \times Z}$$

$$\lambda = \frac{2 \times 3.14 \times 0.529 \times 2^2}{2 \times 2}$$

$$\lambda = 3.33 \text{ \AA}$$

75. Second group anions reacts with

- (1) dil H_2SO_4 (2) Conc. H_2SO_4 (3) dil HCl (4) CH_3COOH

Ans. (2)

Sol. Conc. H_2SO_4 is group reagent for IInd group

76. Correct order of bond dissociation energy

- (1) $\text{Br}_2 > \text{Cl}_2$ (2) $\text{F}_2 > \text{Cl}_2$ (3) $\text{I}_2 > \text{F}_2$ (4) $\text{F}_2 > \text{I}_2$

Ans. (4)

Sol. Bond dissociation energy order $\text{Cl}_2 > \text{Br}_2 > \text{F}_2 > \text{I}_2$

77. When Ag^+ reacts with excess of sodium-thio sulphate then he obtained species having charge & geometry respectively :

- (1) -3, Linear
 (2) -2, tetrahedral
 (3) -1, square planer
 (4) -3, square planar

Ans. (1)

Sol. $\text{AgBr} + 2\text{Na}_2\text{S}_2\text{O}_3 \rightarrow \text{Na}_3 [\text{Ag}(\text{S}_2\text{O}_3)_2] + \text{NaBr}$

Coordination number of Ag^+ is 2 so it has sp hybridization and has linear shape

78. The correct relation is :

- (1) $\Delta G = -RT \ln K/Q$ (2) $\Delta G = +RT \ln K$
 (3) $\Delta G = -RT \ln Q/K$ (4) $\Delta G = +RT \ln Q$

Ans. (1)

Sol. $\Delta G = \Delta G^\circ + RT \ln Q$

$$\Delta G = -RT \ln \frac{K}{Q}$$

79. Which of the following has max. solubility at low pH?

- (1) NH_4Cl (2) NaCl (3) Na_3PO_4 (4) $\text{Sr}(\text{OH})_2$

Ans. (4)

Sol. max solubility at low PH means in acidic solution so

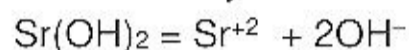

get dissolve in high amount as OH^- get neutralize by H^+

80. Which of the following is correct order of packing efficiency ?

- (1) $\text{HCP} = \text{FCC} > \text{BCC} > \text{SC}$ (2) $\text{SC} > \text{BCC} > \text{HCP} = \text{FCC}$
 (3) $\text{BCC} > \text{SC} > \text{HCP} < \text{FCC}$ (4) $\text{FCC} = \text{HCP} > \text{SC} > \text{BCC}$

Ans. (1)

Sol. packing HCP 74 %

efficiency = FCC 74 %

Sc = 52 %

BCC = 68 %

81. Find empirical formula of the compound if M = 68%

(Atomic mass = 34) and remaining 32% oxygen:

- (1) MO (2) M_2O (3) MO_2 (4) M_2O_3

Ans. (1)

Sol.

Element	% mass	mole
M	68 %	$68/34 = 2$
O	32 %	$32/16 = 2$

Empirical formula = MO

82. Which of the following is a formula of methanides :

- (a) Be_2C (b) CaC_2 (c) Mg_2C_3 (d) SiC
 (1) only a, d (2) only a, b (3) only c, d (4) only b, d

Ans. (1)

Sol. $\text{Be}_2\text{C} + 4\text{H}_2\text{O} \longrightarrow 2\text{Be}(\text{OH})_2 + \text{CH}_4$

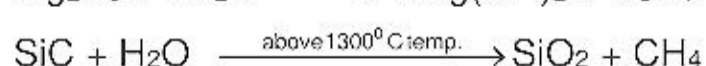
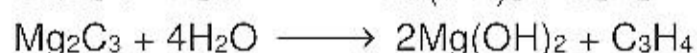
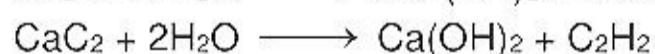

83. Which of the following inert gas participate in chemical reaction.

- (1) Xe (2) He (3) Ne (4) None

Ans. (1)

Sol. Because IP of Xe and oxygen are almost same and atomic size Xe is large.

89. **Assertion** : ZnO becomes yellow when it is heated.

Reason : The anionic sites occupied by unpaired electrons (due to F-centres)

Ans. (1)

Sol. Zinc oxides white in colour at room temperature. On heating it loses oxygen and turns yellow.

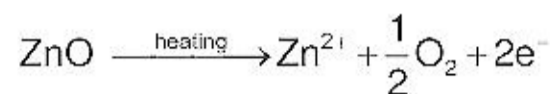

(metal deficiency effect due to presence of extra cations at interstitial sites :)

90. **Assertion** : The graph between P V/s $\frac{1}{V}$ is a straight line.

Reason : For adiabatic process $P \propto \frac{1}{V}$

Ans. (3)

91. **Assertion** : Yb⁺² is more stable in compare to Gd⁺²

Reason : The electronic configuration of Gd is [Xe] 4f⁷ 5d¹ 6s² .

Ans. (3)

Sol. Yb⁺² = [Xe]4f¹⁴, 5d⁰, 6s⁰

Gd⁺² = [Xe]4f⁷, 5d¹, 6s⁰

so Yb⁺² is more stable than Gd⁺²

92. **Assertion** : The chemical properties of different isotope are same.

Reason : Isotopes having same number of neutron.

Ans. (3)

Sol. Isotopes have different number of neutrons

93. Which metals upon heating in presence of air followed by hydrolysis gives Ammonia.

(1) Li, K (2) Rb, Mg (3) Li, Mg (4) Ca, K

Ans. (3)

Sol. $6\text{Li} + \text{N}_2 \rightarrow 2\text{Li}_3\text{N}$

$\text{Li}_3\text{N} + 3\text{H}_2\text{O} \rightarrow 3\text{LiOH} + \text{NH}_3$

$3\text{Mg} + \text{N}_2 \rightarrow \text{Mg}_3\text{N}_2$

$\text{Mg}_3\text{N}_2 + 6\text{H}_2\text{O} \rightarrow 3\text{Mg}(\text{OH})_2 + 2\text{NH}_3$

94. At 25°C 1 mole of butane is heated then CO₂ and H₂O liquid is formed work done is :

(1) 75.6 L atm

(2) 85.6 L atm

(3) 50.3 L atm

(4) None of these

Ans. (2)

Sol. $\text{C}_4\text{H}_{10} + \frac{13}{2}\text{O}_2 \rightarrow 4\text{CO}_2 + 5\text{H}_2\text{O}$

$$\Delta n_g = 4 - \left(1 + \frac{13}{2}\right)$$

$$= -\frac{7}{2}$$

$w = -\Delta n_g RT$

$$= -\left(-\frac{7}{2} \times 0.0821 \times 298\right)$$

$$= 85.6$$

PART - C (BIOLOGY)

95. Identify the diagram.

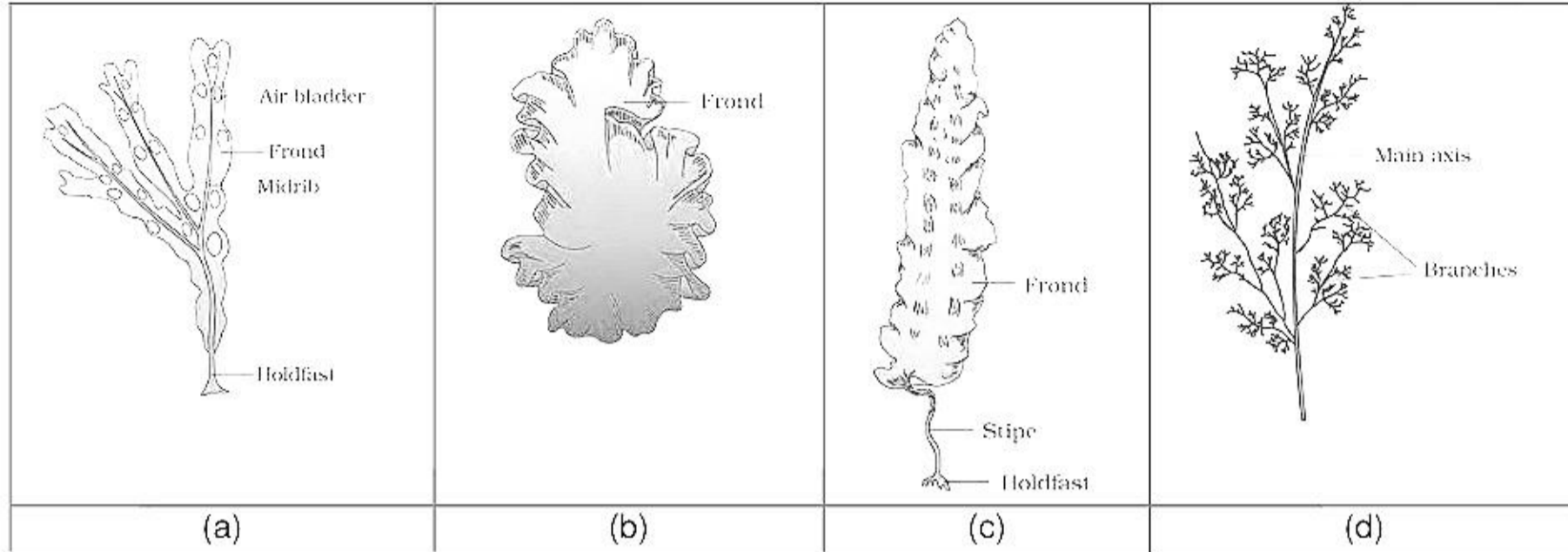

- (1) (a) - Laminaria, (b) - Porphyra, (c) - Fucus (d) - Polysiphonia
 (2) (a) - Polysiphonia, (b) Laminaria -, (c) - Porphyra (d) - Fucus
 (3) (a) -Fucus, (b) - Porphyra, (c) - Laminaria (d) - Polysiphonia
 (4) (a) -Fucus, (b) - Laminaria, (c) - Porphyra (d) - Polysiphonia

Ans (3)

96. Select the correct diagram.

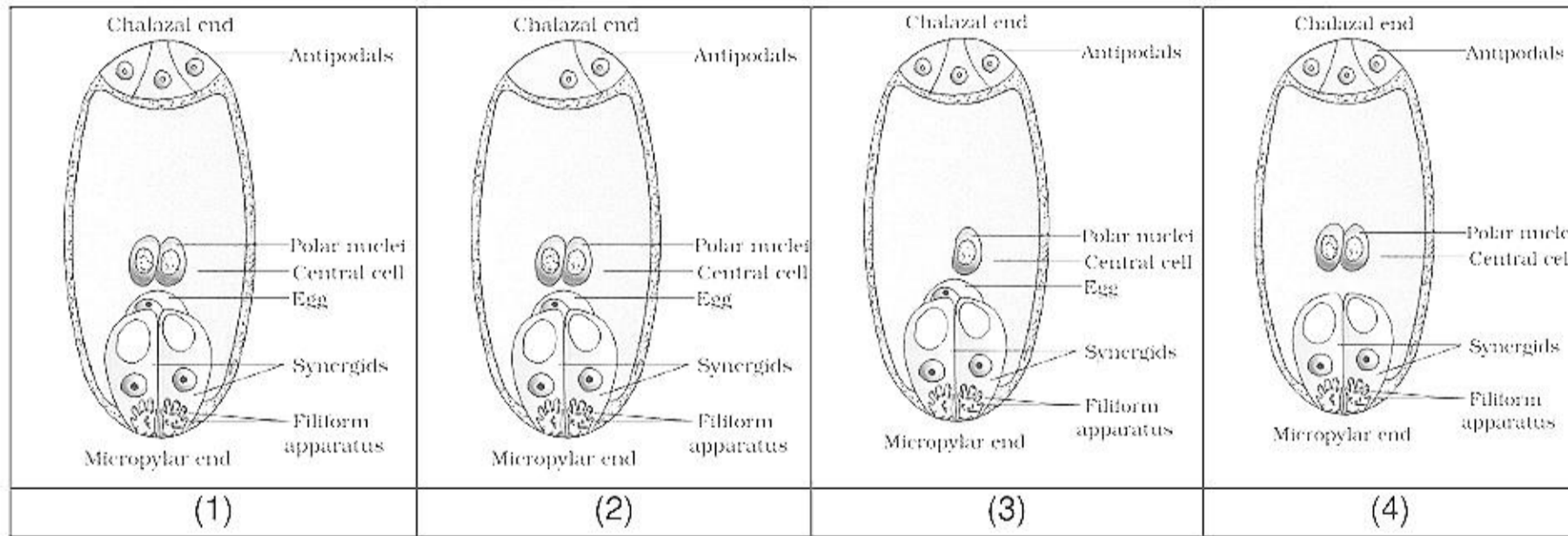

Ans (1)

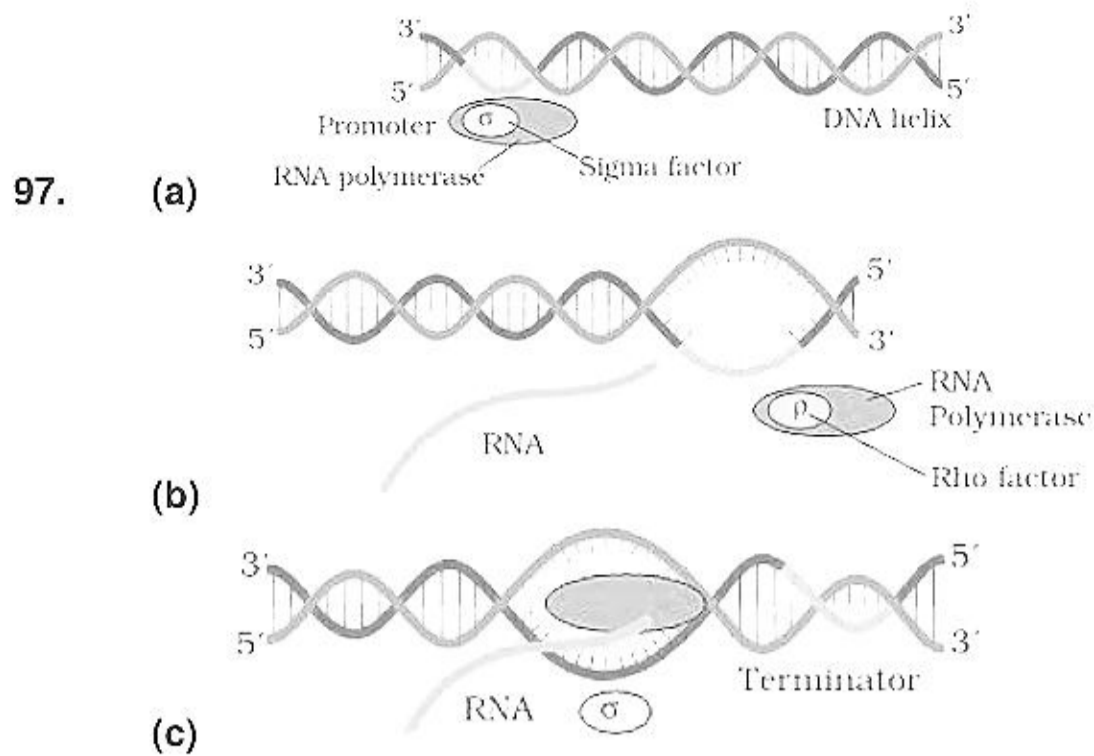

Identify a, b and c

- (1) (a) Elongation, (b) Termination, (c) Initiation
- (2) (a) Initiation, (b) Termination, (c) Elongation
- (3) (a) Initiation, (b) Elongation, (c) Termination
- (4) (a) Termination, (b) Elongation, (c) Initiation

Ans (2)

98. Match the column I and II

	Column-I		Column-II
(a)	Parasitism	(i)	++
(b)	Commensalism	(ii)	+ -
(c)	Amensalism	(iii)	0 +
(d)	Mutualism	(iv)	0 -

- (1) (a) - iii, (b) - ii, (c) - iv, (d) - i
- (2) (a) - i, (b) - ii, (c) - iii, (d) - iv
- (3) (a) - ii, (b) - iii, (c) - i, (d) - iv
- (4) (a) - ii, (b) - iii, (c) - iv, (d) - i

Ans (4)

99. Genes on same chromosome can be

- (1) Linked
- (2) Homologous
- (3) Autosomes
- (4) Identical alleles

Ans (1)

100. Match the Column I with II

Column I

- (1) Pusa Shubhra
- (2) Pusa swarnim
- (3) Pusa sadabahar
- (4) Himgiri

Column II

- (a) Leaf and stripe rust
- (b) Curl blight black rot
- (c) Chilly mosaic virus
- (d) White rust

- (1) 1- a, 2-c, 3-d, 4-b
- (2) 1- b, 2-d, 3-c, 4-a
- (3) 1- d, 2-c, 3-b, 4-a
- (4) 1- a, 2-b, 3-d, 4-c

Ans (2)

- 101.** Which of the following is correct about symplast?
 (1) Living continuum (2) Cell wall and intercellular space
 (3) Non-Living continuum (4) None of these
Ans (1)
- 102.** Match the Column I and II
 (i) Elaioplast (a) Storage of Starch
 (ii) Aleuroplast (b) Storage of fat
 (iii) Amyloplast (c) Storage of protein
 (iv) Chromoplast (d) Colored pigments
 (1) i- a, ii-c, iii-d, iv-b (2) i- d, ii-d, iii-c, iv-a
 (3) i- d, ii-c, iii-d, iv-a (4) i- b, ii-c, iii-a, iv-d
Ans (4)
- 103.** Virus free plants can be formed by
 (1) Meristem culture (2) Callus culture
 (3) Somatic cell culture (4) Protoplast fusion
Ans (1)
- 104.** Which of the following is correct set of macronutrients?
 (1) K, B, C, H (2) K, H, Mn, N (3) C, Zn, H, N (4) C, H, Mg, N
Ans (4)
- 105.** Percentage of (G + C) is
 (1) $\frac{G+C}{(A+G+T+C)} \times 100$
 (2) $\frac{100}{A+T} \times G+C$
 (3) $\frac{G+C}{A+T+G+C}$
 (4) $\frac{(G+C) \times (A+T)}{100}$
Ans. (1)
- 106.** Arrange them on the basis of increasing size:
 (1) Nucleotide, chromosome, gene, genome (2) Genome, chromosome, Nucleotide gene
 (3) Nucleotide, genome, gene, chromosome (4) Nucleotide, gene, chromosome, genome
Ans. (4)
- 107.** Which of the following is microelement?
 (1) Ca (2) Mg (3) Mn (4) S
Ans. (3)
- 108.** The genetic code of proline are :
 (1) CCC CCG CCU (2) CUU UCA CUG
 (3) GUU GUC GUG (4) GGU GUC GGA
Ans. (1)

109. The coding strand of DNA is :
 $5' \text{AATTCAAATTAGG} 3'$
 What is the sequence of mRNA?
 (1) $3' \text{TTAAGTTTAATCC} 5'$ (2) $5' \text{AAUUCAAAUUAGG} 3'$
 (3) $3' \text{AAUUCAAAUUAGG} 5'$ (4) $5' \text{TTAAGTTTAATCC} 3'$

Ans. (2)

110. Match the following :

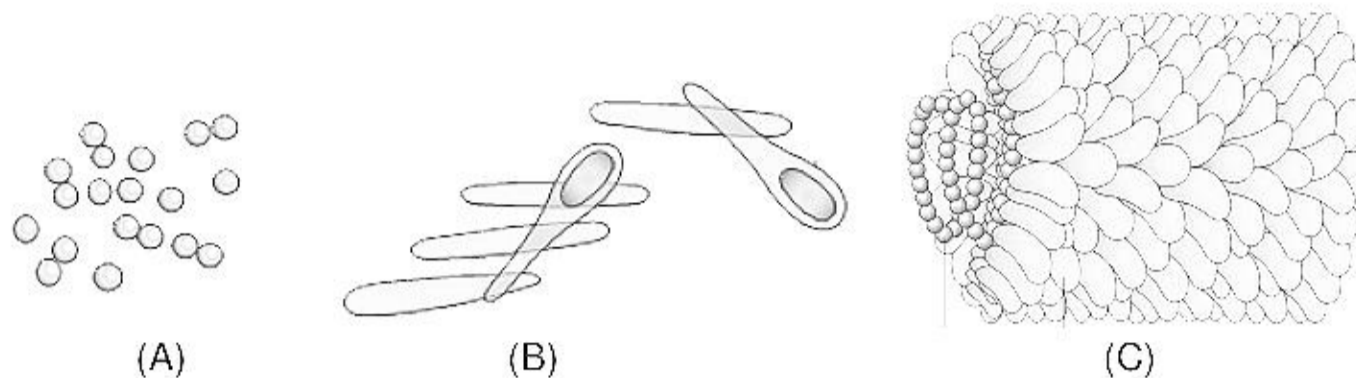

- (1) A– Tobacco mosaic virus, B– Coccus, C– Bacillus
 (2) A–Coccus, B–Bacillus, C–Tobacco mosaic virus
 (3) A– Bacillus, B– Coccus, C– Tobacco mosaic virus
 (4) A– Coccus, B– Tobacco mosaic virus, C– Bacillus

Ans. (2)

111. Synthesis of lipid is function of:
 (1) SER (2) RER
 (3) Golgi body (4) Mitochondria

Ans. (1)

112. DNA polymerase links nucleotide by forming which type of bond:
 (1) Phosphodiester bond (2) Hydrogen bond
 (3) Glycosidic bond (4) Ester bond

Ans. (1)

113. Match the following:
 (a) Siliqua (i) *Lycopersicum esculentum*
 (b) Caryopsis (ii) *Triticum aestivum*
 (c) Berry (iii) *Helianthus annuus*
 (d) Cypsela (iv) *Brassica campestris*

- (1) a-ii, b-i, c-iii, d-iv
 (2) a-i, b-ii, c-iii, d-iv
 (3) a-iv, b-ii, c-i, d-iii
 (4) a-iii, b-ii, c-i, d-iv

Ans. (3)

114. Select the wrong statement:
 (1) The human genome contains 3164.7 million nucleotide bases
 (2) Less than 10% of the genome codes for protein
 (3) Repeated sequences make up very large portion of the human genome
 (4) Chromosome 1 has most genes (2968) and Y has the fewest (231)

Ans. (2)

115. Homologous chromosomes can be defined as:
- (1) Chromatids of same chromosome
 - (2) Same chromosome, same gene, different allele in different order
 - (3) Same chromosome, different gene, same allele
 - (4) Same chromosome, same gene, different allele in same order

Ans. (4)

116. Match the column I and II

	Column-I		Column-II
(a)	Pleiotropic gene	(i)	Both allele express equally
(b)	Co-dominance	(ii)	Change in nucleotide
(c)	Epistasis	(iii)	One gene shows multiple phenotypic expression
(d)	Mutation	(iv)	Non - allelic gene inheritance

- (1) (a) - i, (b) - ii, (c) - iii, (d) - iv
- (2) (a) - ii, (b) - iii, (c) - iv, (d) - i
- (3) (a) - iii, (b) - i, (c) - iv, (d) - ii
- (4) (a) - i, (b) - ii, (c) - iv, (d) - ii

Ans (3)

117. Match the column I and II

	Column-I		Column-II
(a)	K.C. Mehta	(i)	Fluid mosaic model
(b)	P. Maheshwari	(ii)	First recombinant plasmid.
(c)	Cohen and Boyer	(iii)	Haploid culture
(d)	Singer and Nicolson	(iv)	Rust disease

- (1) (a) - i, (b) - iii, (c) - ii, (d) - iv
- (2) (a) - iv, (b) - iii, (c) - ii, (d) - i
- (3) (a) - i, (b) - ii, (c) - iii, (d) - iv
- (4) (a) - ii, (b) - iii, (c) - iv, (d) - i

Ans (2)

118. Choose the correct statement.

- (1) Transcription and translation occur in same compartment for prokaryotes
- (2) Monocistronic RNA-more than one structural genes under single promoter
- (3) Introns and exons both code for protein synthesis
- (4) In prokaryotes, splicing and tailing occurs before translation.

Ans (1)

119. **Assertion :** In eukaryotes, both intron and exon are transcribed to form hnRNA

Reason : Splicing is required in prokaryotes

- (1) If both assertion and reason are true and reason is the correct explanation of assertion.
- (2) If both assertion and reason are true but reason is not the correct explanation of assertion.
- (3) If assertion is true but reason is false.
- (4) If both assertion and reason are false.

Ans (3)

120. **Assertion :** Parthenocarpy involves formation of seedless fruit.

Reason : Apomixis occurs without fertilization.

- (1) If both assertion and reason are true and reason is the correct explanation of assertion.
- (2) If both assertion and reason are true but reason is not the correct explanation of assertion.
- (3) If assertion is true but reason is false.
- (4) If both assertion and reason are false.

Ans (2)

121. **Assertion:** Somaclonal variations produce slight differences in plant.
Reason: They are produced while performing tissue culture.
(1) If both assertion and reason are true and reason is the correct explanation of assertion.
(2) If both assertion and reason are true but reason is not the correct explanation of assertion.
(3) If assertion is true but reason is false.
(4) If both assertion and reason are false.
Ans (2)
122. **Assertion:** In eukaryotes, transcription occurs in nucleus
Reason : In bacteria, transcription and translation occurs in cytoplasm.
(1) If both assertion and reason are true and reason is the correct explanation of assertion.
(2) If both assertion and reason are true but reason is not the correct explanation of assertion.
(3) If assertion is true but reason is false.
(4) If both assertion and reason are false.
Ans (2)
123. **Assertion:** Fig and wasp cannot complete their life cycle without each other.
Reason: It is mutualistic relationship
(1) If both assertion and reason are true and reason is the correct explanation of assertion.
(2) If both assertion and reason are true but reason is not the correct explanation of assertion.
(3) If assertion is true but reason is false.
(4) If both assertion and reason are false.
Ans (1)
124. **Assertion:** Biofortification is used to increase nutrient value of crops
Reason: Meristem culture is used to obtain virus resistant plants
(1) If both assertion and reason are true and reason is the correct explanation of assertion.
(2) If both assertion and reason are true but reason is not the correct explanation of assertion.
(3) If assertion is true but reason is false.
(4) If both assertion and reason are false.
Ans (3)
125. **Assertion:** Isolated protoplasts are used for somatic hybridisation
Reason: Callus culture does not allow variation
(1) If both assertion and reason are true and reason is the correct explanation of assertion.
(2) If both assertion and reason are true but reason is not the correct explanation of assertion.
(3) If assertion is true but reason is false.
(4) If both assertion and reason are false.
Ans (2)
126. **Assertion:** In C_3 cycle, the first stable compound is $3C$ compound
Reason: In C_4 plants Calvin cycle is absent
(1) If both assertion and reason are true and reason is the correct explanation of assertion.
(2) If both assertion and reason are true but reason is not the correct explanation of assertion.
(3) If assertion is true but reason is false.
(4) If both assertion and reason are false.
Ans (3)
127. **Assertion:** In vernalization, flowering is induced by low temperature
Reason: ABA is growth inhibiting hormone
(1) If both assertion and reason are true and reason is the correct explanation of assertion.
(2) If both assertion and reason are true but reason is not the correct explanation of assertion.
(3) If assertion is true but reason is false.
(4) If both assertion and reason are false.
Ans (2)

128. **Assertion:** In commensalism, one organism is benefitted and other is unaffected

Reason: Cattle egret bird and cattle is an example of commensalism

- (1) If both assertion and reason are true and reason is the correct explanation of assertion.
- (2) If both assertion and reason are true but reason is not the correct explanation of assertion.
- (3) If assertion is true but reason is false.
- (4) If both assertion and reason are false.

Ans (2)

129. Identify the given diagram of tissue performing secretion and absorption -

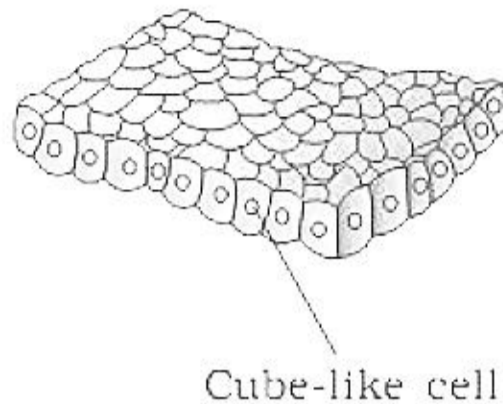

- (1) Simple cuboidal epithelium
- (2) Simple columnar epithelium
- (3) Stratified cuboidal epithelium
- (4) Stratified columnar epithelium

Ans. (1)

130. Cervical vertebrae differ from other vertebra in having -

- (1) Spinous process
- (2) Centrum
- (3) Transverse process
- (4) Transverse foramen

Ans. (4)

131. Protein on reaction with which yields Ruhemann's purple?

- (1) Ninhydrin
- (2) Cu^{2+}
- (3) H_2O_2
- (4) Benedict's solution

Ans. (1)

132. Which maintains static equilibrium -

- (1) Cerebrum
- (2) Utricle & Saccule
- (3) Cerebellum
- (4) Semicircular canal

Ans. (2)

133. Which of the following is correct about biogas –

- (1) Methane gas is produced along with ethyl alcohol by methanogen
- (2) Methanogens acts on cellulose and release biogas
- (3) Biogas is produced by thunder and lightening
- (4) Maximum gas found in biogas is CO_2

Ans. (2)

134. Blood group of the father is A and blood group of mother is B. Then predict the blood group of the progeny -

- (1) A, AB
- (2) A, B, AB, O
- (3) B, AB
- (4) O, A, B

Ans. (2)

135. Skeletal muscles are controlled by -
 (1) Sympathetic nervous system (2) Parasympathetic nervous system
 (3) Somatic nervous system (4) Sympathetic and parasympathetic both
Ans. (3)
136. Hardy Weinberg equilibrium is affected by-
 (1) Natural selection (2) New mutation
 (3) Genetic drift (4) All of the above
Ans. (4)
137. Mark the incorrect statement for inbreeding
 (1) Inbreeding depression increases productivity
 (2) Inbreeding depression can be overcome by outcrossing
 (3) Produces purelines
 (4) Increases homozygosity
Ans (1)
138. Mark the correct one
 (1) Labeo – Internal fertilization (2) Frog – Internal fertilization
 (3) Birds – external fertilization (4) Balaenoptera – internal fertilization
Ans (4)
139. Mark the correct statement regarding earthworm
 (1) One pair of female genital pores are present in 14th segment
 (2) Four pairs of spermathecae are situated on ventro lateral sides of the intersegmental grooves i.e. 5th segments
 (3) Clitellum is present in 13-15 segments
 (4) Four pairs of spermathecae are located in 6th-9th segments
Ans (4)
140. Mark the correct statement
 (1) **Saheli** is once a week oral contraceptive
 (2) Progestasert releases estrogen
 (3) Cu-T is a barrier method
 (4) Vasectomy and tubectomy are temporary methods of contraception
Ans (1)
141. Choose the correct statement for *Periplaneta americana*
 (1) It has 6 muscular hearts
 (2) It has 10 thoracic segments
 (3) Anal style is present in both male and female
 (4) It is nocturnal and present in damp places
Ans (4)
142. Animal of which phylum have hooks and suckers and are endoparasite on other animals
 (1) Platyhelminthes (2) Annelida (3) Ascheminthes (4) Arthropoda
Ans (1)

143. Nucleoside is :

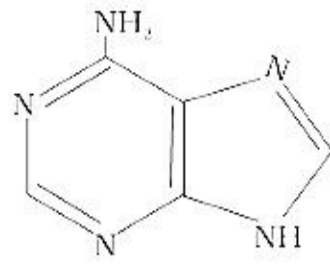

(A)

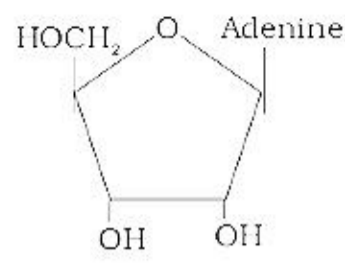

(B)

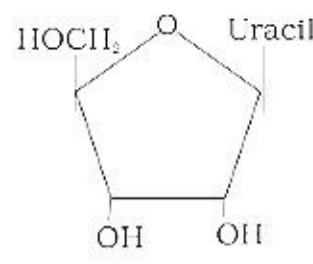

(C)

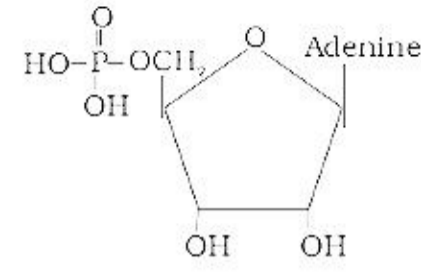

(D)

(1) A and B

(2) B and C

(3) C and D

(4) D and A

Ans. (2)

144. Acoelomate animals with flame cells are :

(1) Platyhelminthes

(2) Annelida

(3) Ascheminthes

(4) Arthropoda

Ans (1)

145. Gene cloning is:

(1) Gene is isolated and inserted in same organism

(2) Gene is isolated and inserted in different organism

(3) Gene is isolated and inserted in plasmid of other organism

(4) Gene is isolated and inserted in chromosomal DNA

Ans. (2)

146. **Assertion:** Amoxicillin is a broad spectrum antibiotic.

Reason: It is derived from penicilin G.

(1) If both assertion and reason are true and reason is the correct explanation of assertion.

(2) If both assertion and reason are true but reason is not the correct explanation of assertion.

(3) If assertion is true but reason is false.

(4) If both assertion and reason are false.

Ans. (3)

147. **Assertion:** 100 ml of blood delivers 5 ml O₂ to tissues in normal conditions

Reason : One molecule of Hb can bind with 4 molecules of O₂

(1) If both assertion and reason are true and reason is the correct explanation of assertion.

(2) If both assertion and reason are true but reason is not the correct explanation of assertion.

(3) If assertion is true but reason is false.

(4) If both assertion and reason are false.

Ans. (2)

148. **Assertion :** Protooncogenes are present in normal cells

Reason : Protooncogenes may causes malignant tumour in animals, if activated.

(1) If both assertion and reason are true and reason is the correct explanation of assertion.

(2) If both assertion and reason are true but reason is not the correct explanation of assertion.

(3) If assertion is true but reason is false.

(4) If both assertion and reason are false.

Ans (2)

149. **Assertion :** Na and K ions are necessary for muscle contraction.
Reason : Na and K concentration changes across the muscle cell membrane resulting in development of potential difference.
(1) If both assertion and reason are true and reason is the correct explanation of assertion.
(2) If both assertion and reason are true but reason is not the correct explanation of assertion.
(3) If assertion is true but reason is false.
(4) If both assertion and reason are false.
Ans (1)
150. **Assertion :** Malpighian tubules are excretory organs in most of the insects.
Reason : These help in excretion of urea and creatinine.
(1) If both assertion and reason are true and reason is the correct explanation of assertion.
(2) If both assertion and reason are true but reason is not the correct explanation of assertion.
(3) If assertion is true but reason is false.
(4) If both assertion and reason are false.
Ans (3)
151. **Assertion :** Opioids are used as drugs of abuse.
Reason : These slow down metabolism and produce hallucinations.
(1) If both assertion and reason are true and reason is the correct explanation of assertion.
(2) If both assertion and reason are true but reason is not the correct explanation of assertion.
(3) If assertion is true but reason is false.
(4) If both assertion and reason are false.
Ans (3)
152. **Assertion :** Amount of cyanocobalamine required daily is 3 mcg.
Reason : Its deficiency causes pernicious anaemia
(1) If both assertion and reason are true and reason is the correct explanation of assertion.
(2) If both assertion and reason are true but reason is not the correct explanation of assertion.
(3) If assertion is true but reason is false.
(4) If both assertion and reason are false.
Ans (2)

PART - D (GENERAL KNOWLEDGE) & (APTITUDE & LOGICAL THINKING)

153. Arrange the following states in decreasing order of their LOK SABHA seats.

- (1) Madhya Pradesh > Maharashtra > Bihar > West Bengal
- (2) Maharashtra > Bihar > West Bengal > Madhya Pradesh
- (3) Madhya Pradesh > Maharashtra > Bihar > West Bengal
- (4) Maharashtra > West Bengal > Bihar > Madhya Pradesh

Ans. **4. Maharashtra > West Bengal > Bihar > Madhya Pradesh**

154. Loksabha Elections 2019 have been conducted in how many phases?

Ans. **7**

155. Rafale fighter aircraft is designed & built by which company?

Ans. **Dassault Aviation**

156. In a Shopping Plaza, 20% discount is being offered on a product of Rs. 2000/-. If the Shop Owner offers 10% additional discount on the actual/initial price at the time of billing, what will the final price of the product?

- (1) 1800
- (2) 1600
- (3) 1440
- (4) 1400

Ans. **1400**

157. There are 2 Blue, 2 Green & 2 Red balls in a Bag. If 3 of these balls are taken out of the bag, what is the probability that there is One ball of each color in these three.

Ans. **2/5**

158.

2	1
1	5

2	1
3	7

3	1
1	?

Ans.

159. WikiLeaks founder Julian Assange was arrested recently from the embassy of

- (1) France
- (2) Italy
- (3) Ecuador
- (4) Dubai

Ans. **(3) Ecuador**

160. What will be the next number in the series 1, 2, 4, 7, 11, ?

Ans. **16**

161. My Sister is half of my age. After 10 Years, She will be $\frac{3}{4}$ th of my age. How old is she now ?

Ans. **5 Years**

162. There are 3 bells. Bell 1 rings after every 3 minutes, bell 2 after every 6 minutes & bell 3 after every 15 minutes. After how many minutes will they ring together?

Ans. **30 Minutes**

163. Among the following rivers, Which river has a different direction of flow?

- (1) Godavari
- (2) Kaveri
- (3) Narmada
- (4) Krishna

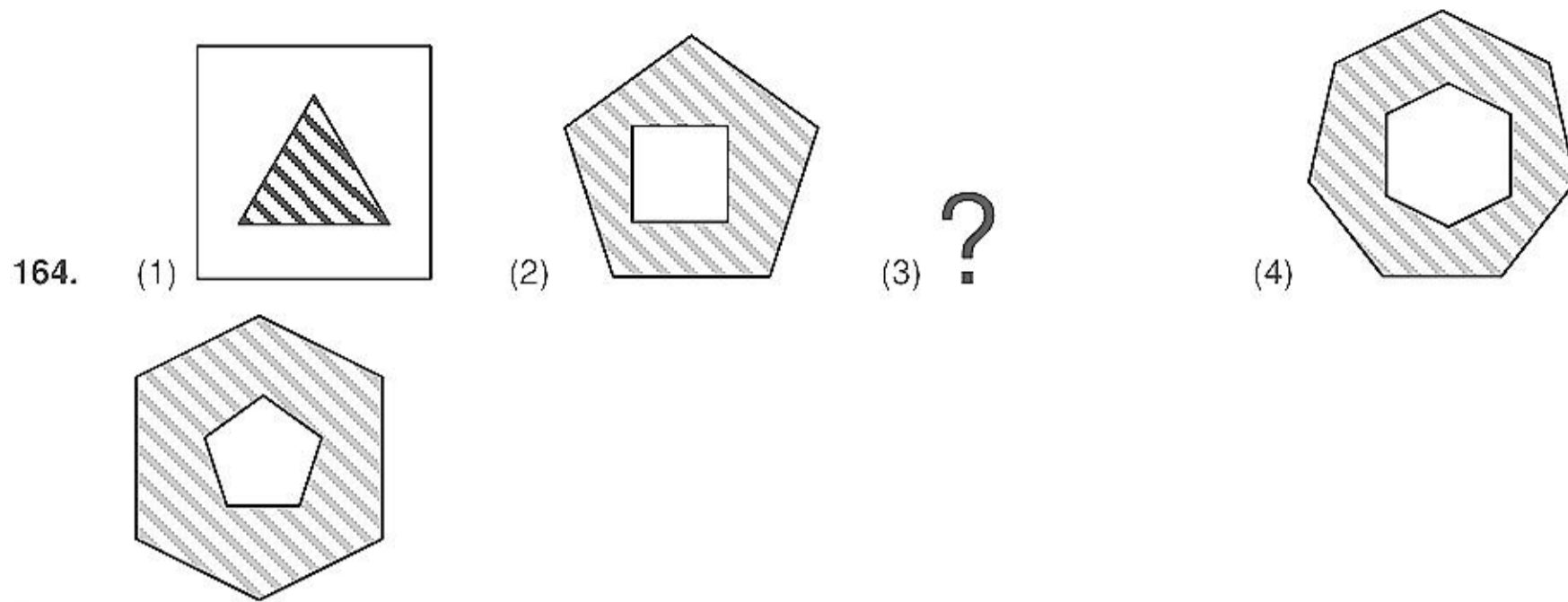

Ans.

165. 80 students can speak English, 60 French and 50 German. 40 students speak English and French. 30 students speak French and German, 25 students speak English and German and 10 students speak all 3 languages.

How many students can speak only 2 language?

Ans.

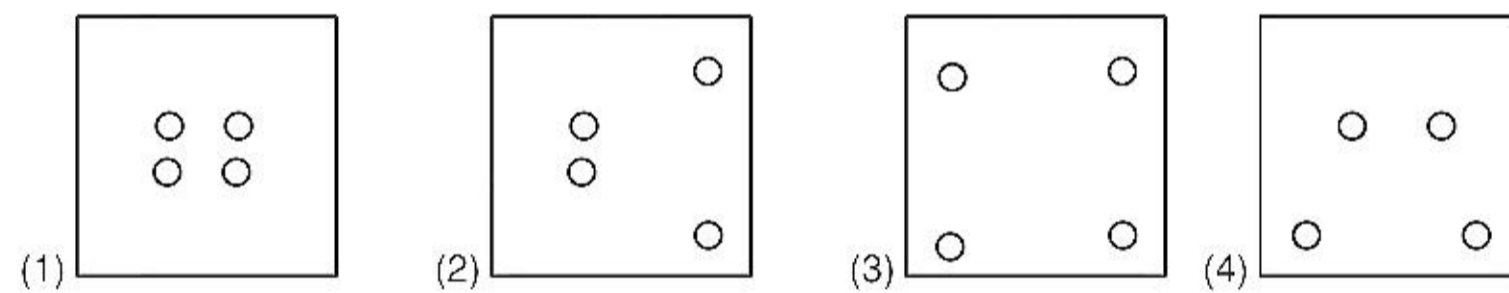
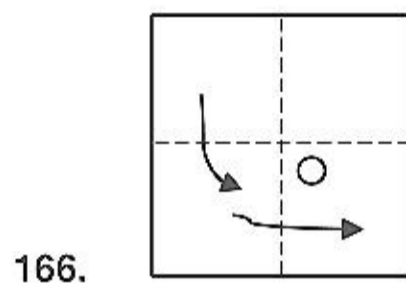

Ans. (1)

167. India : C :: UK : ?

Ans. £