

# National Testing Agency

<b>Question Paper Name :</b>	B TECH EM 18th March 2021 Shift 1
<b>Subject Name :</b>	B TECH EM
<b>Creation Date :</b>	2021-03-18 14:10:31
<b>Duration :</b>	180
<b>Number of Questions :</b>	90
<b>Total Marks :</b>	300
<b>Display Marks:</b>	Yes

## B TECH EM

<b>Group Number :</b>	1
<b>Group Id :</b>	86435159
<b>Group Maximum Duration :</b>	0
<b>Group Minimum Duration :</b>	180
<b>Show Attended Group? :</b>	No
<b>Edit Attended Group? :</b>	No
<b>Break time :</b>	0
<b>Group Marks :</b>	300
<b>Is this Group for Examiner? :</b>	No

## Physics Section A

<b>Section Id :</b>	864351349
<b>Section Number :</b>	1
<b>Section type :</b>	Online
<b>Mandatory or Optional :</b>	Mandatory
<b>Number of Questions :</b>	20
<b>Number of Questions to be attempted :</b>	20
<b>Section Marks :</b>	80
<b>Mark As Answered Required? :</b>	Yes
<b>Sub-Section Number :</b>	1
<b>Sub-Section Id :</b>	864351349
<b>Question Shuffling Allowed :</b>	Yes

**Question Number : 1 Question Id : 8643515221 Question Type : MCQ Option Shuffling : Yes Is Question Mandatory : No Correct Marks : 4 Wrong Marks : 1**

An oil drop of radius 2 mm with a density  $3 \text{ g cm}^{-3}$  is held stationary under a constant electric field  $3.55 \times 10^5 \text{ V m}^{-1}$  in the Millikan's oil drop experiment. What is the number of excess electrons that the oil drop will possess ?

Consider  $g = 9.81 \text{ m/s}^2$

**Options :**

86435115661.  $17.3 \times 10^{10}$

86435115662.  $1.73 \times 10^{10}$

86435115663.  $1.73 \times 10^{12}$

86435115664.  $48.8 \times 10^{11}$

**Question Number : 1 Question Id : 8643515221 Question Type : MCQ Option Shuffling : Yes Is Question Mandatory : No**

**Correct Marks : 4 Wrong Marks : 1**

मिलीकन तेल थेंबाच्या प्रयोगात, 2 mm त्रिज्येचा व  $3 \text{ g cm}^{-3}$  घनतेचा तेलाचा थेंब  $3.55 \times 10^5 \text{ V m}^{-1}$  स्थिर विद्युत क्षेत्रात स्थिर ठेवला आहे. तेलाच्या थेंबात किती जास्त इलेक्ट्रॉनाची संख्या आहे ?

$g = 9.81 \text{ m/s}^2$  विचारात घ्या.

**Options :**

86435115661.  $17.3 \times 10^{10}$

86435115662.  $1.73 \times 10^{10}$

86435115663.  $1.73 \times 10^{12}$

86435115664.  $48.8 \times 10^{11}$

**Question Number : 2 Question Id : 8643515222 Question Type : MCQ Option Shuffling : Yes Is Question Mandatory : No**

**Correct Marks : 4 Wrong Marks : 1**

A constant power delivering machine has towed a box, which was initially at rest, along a horizontal straight line. The distance moved by the box in time 't' is proportional to :

**Options :**

86435115665.  $t^{3/2}$

86435115666.  $t^{1/2}$ 86435115667.  $t^{2/3}$ 86435115668.  $t$ 

**Question Number : 2 Question Id : 8643515222 Question Type : MCQ Option Shuffling : Yes Is Question Mandatory : No**

**Correct Marks : 4 Wrong Marks : 1**

एका स्थिर शक्ती देणाऱ्या अभियंत्राने सुरुवातीस स्थिर असलेले खोके क्षितिजसमांतर सरळ रेषेत ओढून नेले. खोक्याने पार केलेले अंतर 't' वेळात \_\_\_\_\_ ला समानुपाती आहे.

**Options :**

86435115665.  $t^{3/2}$ 86435115666.  $t^{1/2}$ 86435115667.  $t^{2/3}$ 86435115668.  $t$ 

**Question Number : 3 Question Id : 8643515223 Question Type : MCQ Option Shuffling : Yes Is Question Mandatory : No**

**Correct Marks : 4 Wrong Marks : 1**

Four identical long solenoids A, B, C and D are connected to each other as shown in the figure. If the magnetic field at the center of A is 3 T, the field at the center of C would be : (Assume that the magnetic field is confined within the volume of respective solenoid).

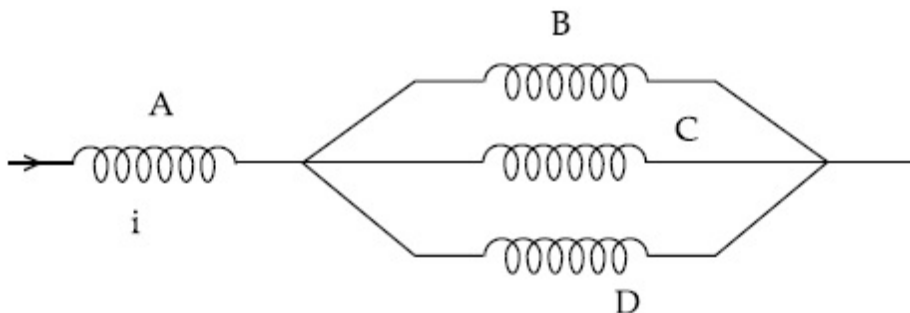

**Options :**

86435115669. 1 T

86435115670. 9 T

86435115671. 6 T

86435115672. 12 T

**Question Number : 3 Question Id : 8643515223 Question Type : MCQ Option Shuffling : Yes Is Question Mandatory : No**

**Correct Marks : 4 Wrong Marks : 1**

आकृतीत दाखविल्याप्रमाणे चार एकसारखे A, B, C व D हे लांब सोलेनॉइड एकमेकास जोडले आहेत. जर A च्या मध्यभागी चुंबकीय क्षेत्र 3 T आहे, C च्या मध्यभागी क्षेत्र \_\_\_\_\_ असू शकेल.

(असे माना कि चुंबकीय क्षेत्र सोलेनॉइडच्या आकारमानात बंदिस्त आहे.)

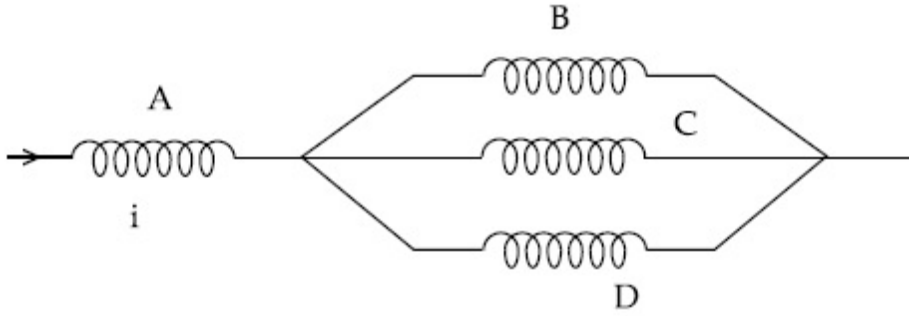

**Options :**

86435115669. 1 T

86435115670. 9 T

86435115671. 6 T

86435115672. 12 T

**Question Number : 4 Question Id : 8643515224 Question Type : MCQ Option Shuffling : Yes Is Question Mandatory : No**

**Correct Marks : 4 Wrong Marks : 1**

The P-V diagram of a diatomic ideal gas system going under cyclic process as shown in figure. The work done during an adiabatic process CD is (use  $\gamma = 1.4$ ) :

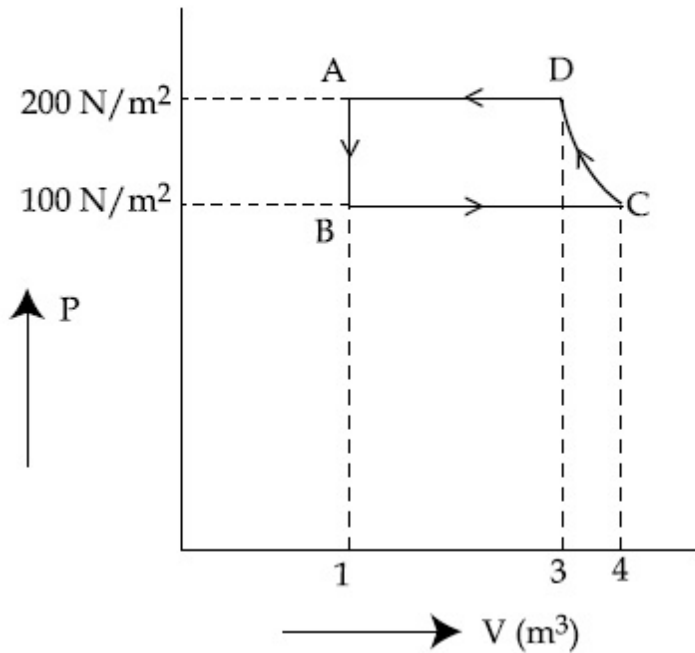

Options :

86435115673. 400 J

86435115674. -500 J

86435115675. 200 J

86435115676. -400 J

Question Number : 4 Question Id : 8643515224 Question Type : MCQ Option Shuffling : Yes Is Question Mandatory : No Correct Marks : 4 Wrong Marks : 1

आकृतीत चक्रीय पद्धतीत असणाऱ्या द्विअण्विक आदर्श वायू संहतीसाठी P-V आकृती दाखविली आहे. समोष्ण पद्धती CD मध्ये केलेले कार्य \_\_\_\_\_ आहे.

( $\gamma = 1.4$  वापरा)

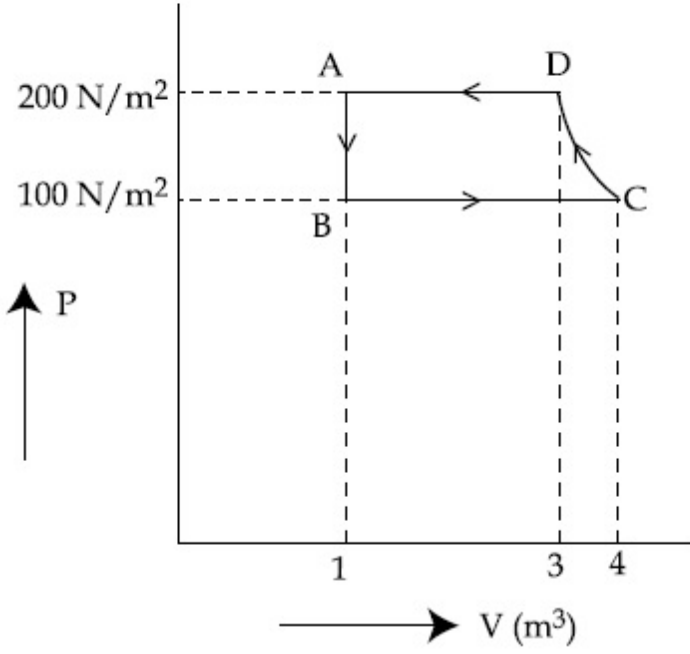

Options :

86435115673. 400 J

86435115674. -500 J

86435115675. 200 J

86435115676. -400 J

Question Number : 5 Question Id : 8643515225 Question Type : MCQ Option Shuffling : Yes Is Question Mandatory : No

Correct Marks : 4 Wrong Marks : 1

The position, velocity and acceleration of a particle moving with a constant acceleration can be represented by :

Options :

86435115677.

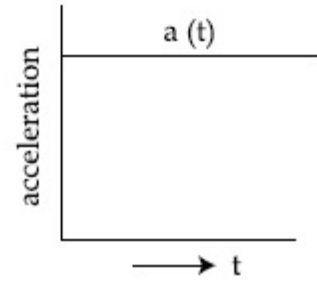
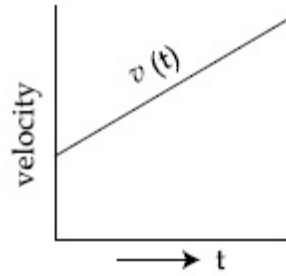
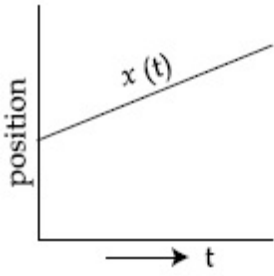

86435115678.

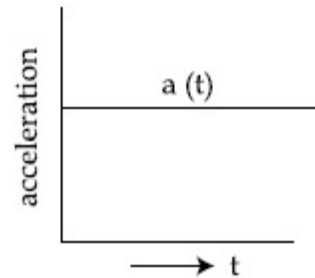
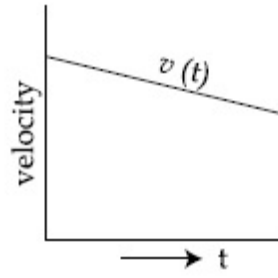
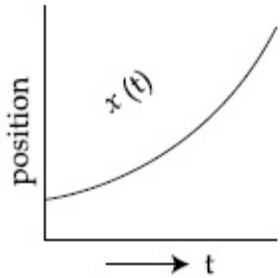

86435115679.

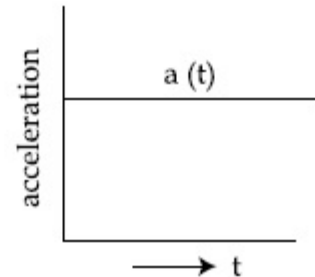
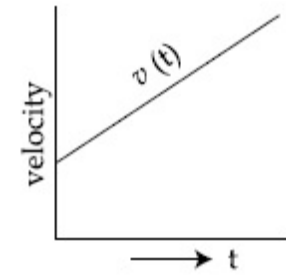
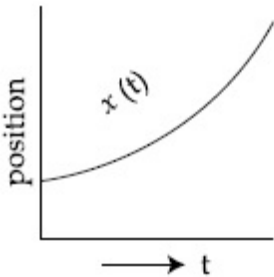

86435115680.

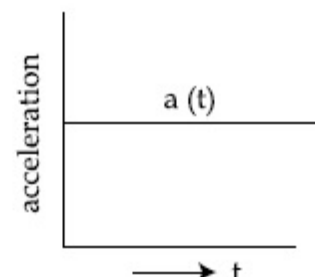
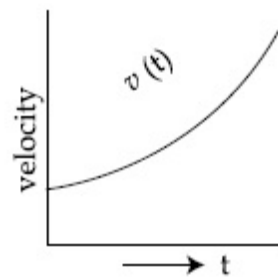
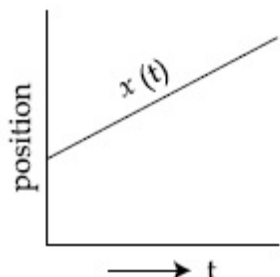

**Question Number : 5 Question Id : 8643515225 Question Type : MCQ Option Shuffling : Yes Is Question Mandatory : No**

**Correct Marks : 4 Wrong Marks : 1**

स्थिर त्वरणाने जाणाऱ्या एका कणासाठी, स्थिती, वेग व त्वरण \_\_\_\_\_ असे दाखविले आहे.

**Options :**

86435115677.

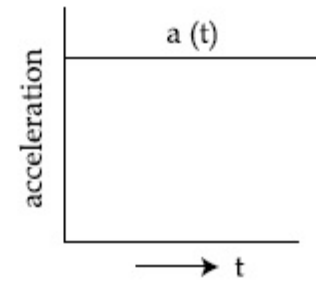
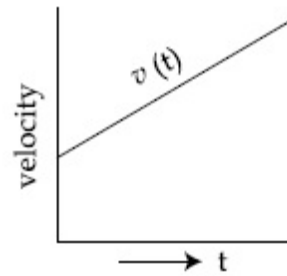
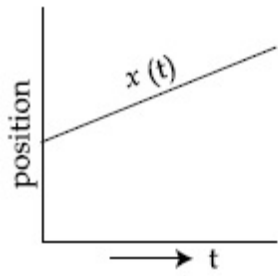

86435115678.

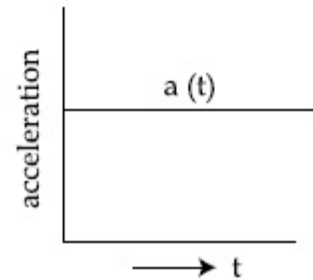
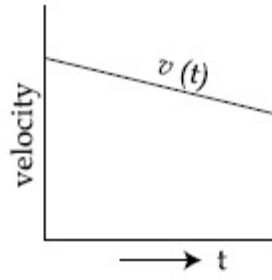
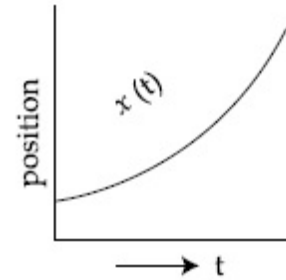

86435115679.

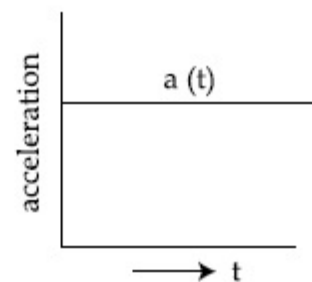
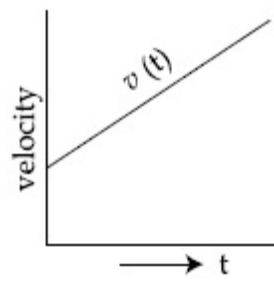
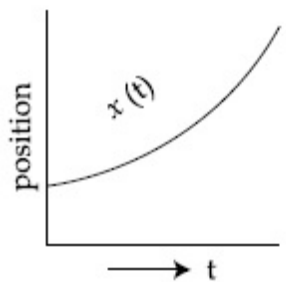

86435115680.

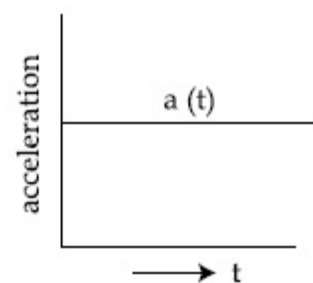
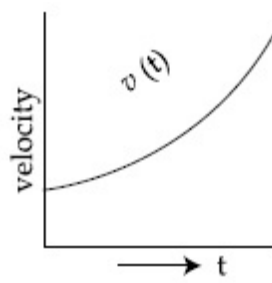
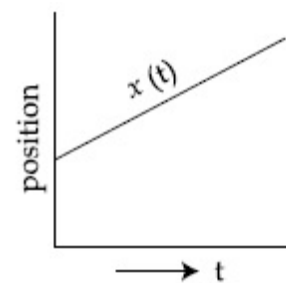

Question Number : 6 Question Id : 8643515226 Question Type : MCQ Option Shuffling : Yes Is Question Mandatory : No

Correct Marks : 4 Wrong Marks : 1

An AC source rated 220 V, 50 Hz is connected to a resistor. The time taken by the current to change from its maximum to the rms value is :

Options :

86435115681. 2.5 ms



86435115682. 25 ms

86435115683. 0.25 ms

86435115684. 2.5 s

**Question Number : 6 Question Id : 8643515226 Question Type : MCQ Option Shuffling : Yes Is Question Mandatory : No**

**Correct Marks : 4 Wrong Marks : 1**

220 V, 50 Hz चा प्रत्यावर्ती धारा उद्गम रोधास जोडलेला आहे. धारेने महत्तम पासून वर्गमाध्य वर्गमूळ मूल्यापर्यंत बदलण्यासाठी घेतलेला वेळ \_\_\_\_\_ आहे.

**Options :**

86435115681. 2.5 ms

86435115682. 25 ms

86435115683. 0.25 ms

86435115684. 2.5 s

**Question Number : 7 Question Id : 8643515227 Question Type : MCQ Option Shuffling : Yes Is Question Mandatory : No**

**Correct Marks : 4 Wrong Marks : 1**

In Young's double slit arrangement, slits are separated by a gap of 0.5 mm, and the screen is placed at a distance of 0.5 m from them. The distance between the first and the third bright fringe formed when the slits are illuminated by a monochromatic light of 5890 Å is :

**Options :**

86435115685.  $1178 \times 10^{-12}$  m

86435115686.  $5890 \times 10^{-7}$  m

86435115687.  $1178 \times 10^{-9}$  m

86435115688.  $1178 \times 10^{-6}$  m

**Question Number : 7 Question Id : 8643515227 Question Type : MCQ Option Shuffling : Yes Is Question Mandatory : No**

**Correct Marks : 4 Wrong Marks : 1**

यंगच्या दोन फटींच्या मांडणीत, फटी 0.5 mm अंतरालाने बाजूला आहे व त्यापासून पडदा 0.5 m वर ठेवला आहे. जेव्हा 5890 Å चा एकवर्णी प्रकाशाने फटी दिप्त झाल्या तेव्हा पहिल्या आणि तिसऱ्या झल्लरींमधील रुंदी \_\_\_\_\_ आहे.

**Options :**

86435115685.  $1178 \times 10^{-12}$  m

86435115686.  $5890 \times 10^{-7}$  m

86435115687.  $1178 \times 10^{-9}$  m

86435115688.  $1178 \times 10^{-6}$  m

**Question Number : 8 Question Id : 8643515228 Question Type : MCQ Option Shuffling : Yes Is Question Mandatory : No**

**Correct Marks : 4 Wrong Marks : 1**

A particle is travelling 4 times as fast as an electron. Assuming the ratio of de-Broglie wavelength of a particle to that of electron is 2 : 1, the mass of the particle is :

**Options :**

86435115689. 8 times the mass of  $e^-$

86435115690.  $\frac{1}{16}$  times the mass of  $e^-$

86435115691. 16 times the mass of  $e^-$

86435115692.  $\frac{1}{8}$  times the mass of  $e^-$

**Question Number : 8 Question Id : 8643515228 Question Type : MCQ Option Shuffling : Yes Is Question Mandatory : No**

**Correct Marks : 4 Wrong Marks : 1**

एक कण इलेक्ट्रॉनच्या चारपट वेगाने जात आहे. कणाच्या डि-ब्रोगीली तरंगलांबीचे इलेक्ट्रॉन बरोबरचे गुणोत्तर 2 : 1 आहे, कणाचे वस्तुमान \_\_\_\_\_ आहे.

**Options :**

86435115689. 8 पट इलेक्ट्रॉनच्या वस्तुमानाच्या

86435115690.  $\frac{1}{16}$  पट इलेक्ट्रॉनच्या वस्तुमानाच्या

86435115691. 16 पट इलेक्ट्रॉनच्या वस्तुमानाच्या

86435115692.  $\frac{1}{8}$  पट इलेक्ट्रॉनच्या वस्तुमानाच्या

**Question Number : 9 Question Id : 8643515229 Question Type : MCQ Option Shuffling : Yes Is Question Mandatory : No**

**Correct Marks : 4 Wrong Marks : 1**

The time period of a simple pendulum is given by  $T = 2\pi\sqrt{\frac{l}{g}}$ . The measured value of the length of pendulum is 10 cm known to a 1 mm accuracy. The time for 200 oscillations of the pendulum is found to be 100 second using a clock of 1 s resolution. The percentage accuracy in the determination of 'g' using this pendulum is 'x'. The value of 'x' to the nearest integer is,

**Options :**

86435115693. 2%

86435115694. 3%

86435115695. 4%

86435115696. 5%

**Question Number : 9 Question Id : 8643515229 Question Type : MCQ Option Shuffling : Yes Is Question Mandatory : No**

**Correct Marks : 4 Wrong Marks : 1**

साध्या दोलकाचा काल  $T = 2\pi\sqrt{\frac{l}{g}}$  असा दिला आहे. दोलकाच्या मोजलेल्या लांबीचे मूल्य 10 cm असून अचुकता 1 mm आहे. दोलकाच्या 200 दोलनांसाठी लागलेला वेळ 100 सेकंद आहे, 1 सेकंद वियोजन असलेले घड्याळ वापरून. हा दोलक वापरून 'g' मोजण्यासाठी टक्केवारीतील अचुकता 'x' आहे. 'x' चे मूल्य जवळच्या पूर्णांकापर्यंत \_\_\_\_\_ आहे.

**Options :**

86435115693. 2%

86435115694. 3%

86435115695. 4%

86435115696. 5%

**Question Number : 10 Question Id : 8643515230 Question Type : MCQ Option Shuffling : Yes Is Question Mandatory : No**

**Correct Marks : 4 Wrong Marks : 1**

Imagine that the electron in a hydrogen atom is replaced by a muon ( $\mu$ ). The mass of muon particle is 207 times that of an electron and charge is equal to the charge of an electron. The ionization potential of this hydrogen atom will be :

**Options :**

86435115697. 13.6 eV

86435115698. 27.2 eV

86435115699. 331.2 eV

86435115700. 2815.2 eV

**Question Number : 10 Question Id : 8643515230 Question Type : MCQ Option Shuffling : Yes Is Question Mandatory : No**

**Correct Marks : 4 Wrong Marks : 1**

अशी कल्पना करा कि हायड्रोजन अणूमधील इलेक्ट्रॉन म्युऑन ( $\mu$ ) ने प्रतिस्थापीत केला. म्युऑन कणाचे वस्तुमान इलेक्ट्रॉनच्या 207 पट आहे व प्रभार इलेक्ट्रॉन एवढा आहे. ह्या हायड्रोजन अणुचे आयनन विभव \_\_\_\_\_ असेल.

**Options :**

86435115697. 13.6 eV

86435115698. 27.2 eV

86435115699. 331.2 eV

86435115700. 2815.2 eV

**Question Number : 11 Question Id : 8643515231 Question Type : MCQ Option Shuffling : Yes Is Question Mandatory : No**

**Correct Marks : 4 Wrong Marks : 1**

A radioactive sample disintegrates via two independent decay processes having half lives

$T_{1/2}^{(1)}$  and  $T_{1/2}^{(2)}$  respectively. The effective half-life,  $T_{1/2}$  of the nuclei is :

**Options :**

86435115701. 
$$T_{1/2} = \frac{T_{1/2}^{(1)} T_{1/2}^{(2)}}{T_{1/2}^{(1)} + T_{1/2}^{(2)}}$$

86435115702. 
$$T_{1/2} = T_{1/2}^{(1)} + T_{1/2}^{(2)}$$

86435115703. 
$$T_{1/2} = \frac{T_{1/2}^{(1)} + T_{1/2}^{(2)}}{T_{1/2}^{(1)} - T_{1/2}^{(2)}}$$

86435115704. None of the above

**Question Number : 11 Question Id : 8643515231 Question Type : MCQ Option Shuffling : Yes Is Question Mandatory : No**

**Correct Marks : 4 Wrong Marks : 1**

एका किरणोत्सारी नमुन्याचे दोन वेगवेगळ्या पद्धतीने न्हास होऊन विघटन होते व त्यांचा अर्ध आयुकाल अनुक्रमे  $T_{1/2}^{(1)}$  व  $T_{1/2}^{(2)}$  आहे. परिणामी केंद्रकाचा अर्ध आयुकाल \_\_\_\_\_ आहे.

**Options :**

$$T_{1/2} = \frac{T_{1/2}^{(1)} T_{1/2}^{(2)}}{T_{1/2}^{(1)} + T_{1/2}^{(2)}}$$

86435115701.

$$T_{1/2} = T_{1/2}^{(1)} + T_{1/2}^{(2)}$$

86435115702.

$$T_{1/2} = \frac{T_{1/2}^{(1)} + T_{1/2}^{(2)}}{T_{1/2}^{(1)} - T_{1/2}^{(2)}}$$

86435115703.

86435115704. वरीलपैकी कोणताही नाही

**Question Number : 12 Question Id : 8643515232 Question Type : MCQ Option Shuffling : Yes Is Question Mandatory : No**

**Correct Marks : 4 Wrong Marks : 1**

A loop of flexible wire of irregular shape carrying current is placed in an external magnetic field. Identify the effect of the field on the wire.

**Options :**

86435115705. shape of the loop remains unchanged

86435115706. loop assumes circular shape with its plane normal to the field

86435115707. loop assumes circular shape with its plane parallel to the field

86435115708. wire gets stretched to become straight

**Question Number : 12 Question Id : 8643515232 Question Type : MCQ Option Shuffling : Yes Is Question Mandatory : No**

**Correct Marks : 4 Wrong Marks : 1**

एक लवचिक तारेचे कडे अनियमित आकाराचे असून त्यातून धारा वाहते व ते बाह्य चुंबकीय क्षेत्रात ठेवले आहे. तारेवर क्षेत्राचा परिणाम ओळखा.

**Options :**

86435115705. कड्याचा आकार बदलत नाही.

86435115706. कडे वर्तुळाकार आकार घेते व त्याचे प्रतल क्षेत्रास लंबरूप आहे.

86435115707. कडे वर्तुळाकार आकार घेते व त्याचे प्रतल क्षेत्रास समांतर आहे.

86435115708. तार ताणून सरळ होते.

**Question Number : 13 Question Id : 8643515233 Question Type : MCQ Option Shuffling : Yes Is**

**Question Mandatory : No**

**Correct Marks : 4 Wrong Marks : 1**

In the experiment of Ohm's law, a potential difference of 5.0 V is applied across the end of a conductor of length 10.0 cm and diameter of 5.00 mm. The measured current in the conductor is 2.00 A. The maximum permissible percentage error in the resistivity of the conductor is :

**Options :**

86435115709. 3.9

86435115710. 7.5

86435115711. 8.4

86435115712. 3.0

**Question Number : 13 Question Id : 8643515233 Question Type : MCQ Option Shuffling : Yes Is**

**Question Mandatory : No**

**Correct Marks : 4 Wrong Marks : 1**

ओहमच्या नियमाच्या प्रयोगात, 5.0 V चे विभवांतर 5.00 mm व्यास व 10.0 cm लांबीच्या वाहकाच्या टोकांना लावले. वाहकातील मोजलेली धारा 2.00 A आहे. वाहकाच्या रोधितेमधील महत्तम चालू शकणारी टक्केवारीतील त्रुटी \_\_\_\_\_ आहे.

**Options :**

86435115709. 3.9

86435115710. 7.5

86435115711. 8.4

86435115712. 3.0

**Question Number : 14 Question Id : 8643515234 Question Type : MCQ Option Shuffling : Yes Is Question Mandatory : No**

**Correct Marks : 4 Wrong Marks : 1**

The time period of a satellite in a circular orbit of radius  $R$  is  $T$ . The period of another satellite in a circular orbit of radius  $9R$  is :

**Options :**

86435115713. 3 T

86435115714. 9 T

86435115715. 27 T

86435115716. 12 T

**Question Number : 14 Question Id : 8643515234 Question Type : MCQ Option Shuffling : Yes Is Question Mandatory : No**

**Correct Marks : 4 Wrong Marks : 1**

$R$  त्रिज्या असलेल्या वर्तुळाकार कक्षेतील उपग्रहाचा काल  $T$  आहे. दूसऱ्या उपग्रहाचा  $9R$  त्रिज्या असलेल्या वर्तुळाकार कक्षेत काल \_\_\_\_\_ आहे.

**Options :**

86435115713. 3 T

86435115714. 9 T

86435115715. 27 T

86435115716. 12 T



**Question Number : 15 Question Id : 8643515235 Question Type : MCQ Option Shuffling : Yes Is Question Mandatory : No**

**Correct Marks : 4 Wrong Marks : 1**

In a series LCR resonance circuit, if we change the resistance only, from a lower to higher value :

**Options :**

86435115717. The resonance frequency will increase

86435115718. The bandwidth of resonance circuit will increase

86435115719. The quality factor will increase

86435115720. The quality factor and the resonance frequency will remain constant

**Question Number : 15 Question Id : 8643515235 Question Type : MCQ Option Shuffling : Yes Is Question Mandatory : No**

**Correct Marks : 4 Wrong Marks : 1**

LCR संस्पंदी परिपथात, जर आपण फक्त रोध बदलला, कमी पासून जास्त मूल्यापर्यंत \_\_\_\_\_.

**Options :**

86435115717. संस्पंदी वारंवारता वाढेल.

86435115718. संस्पंदी परिपथातील पट्टरुंदी वाढेल.

86435115719. गुण अवयव वाढेल.

86435115720. गुण अवयव व संस्पंदी वारंवारीता स्थिर राहिल.

**Question Number : 16 Question Id : 8643515236 Question Type : MCQ Option Shuffling : Yes Is Question Mandatory : No**

**Correct Marks : 4 Wrong Marks : 1**

Your friend is having eye sight problem. She is not able to see clearly a distant uniform window mesh and it appears to her as non-uniform and distorted. The doctor diagnosed the problem as :

**Options :**

86435115721. Myopia and hypermetropia

86435115722. Presbyopia with Astigmatism

86435115723. Astigmatism

86435115724. Myopia with Astigmatism

**Question Number : 16 Question Id : 8643515236 Question Type : MCQ Option Shuffling : Yes Is Question Mandatory : No**

**Correct Marks : 4 Wrong Marks : 1**

तुमच्या मित्रास दृष्टीदोष आहे. ती लांबची एकसमान खिडकीची जाळी स्वच्छपणे पाहू शकत नाही. आणि तिला ती एकसमान नसलेली व विकृत दिसते. डॉक्टरने त्या प्रश्नाचे निदान असे केले कि :

**Options :**

86435115721. निकटदृष्टीता व दूरदृष्टीता

86435115722. अर्बिंदूकते बरोबर प्रेसबायोपिआ

86435115723. अर्बिंदूकता

86435115724. अर्बिंदूकते बरोबर निकटदृष्टीता

**Question Number : 17 Question Id : 8643515237 Question Type : MCQ Option Shuffling : Yes Is Question Mandatory : No**

**Correct Marks : 4 Wrong Marks : 1**

What will be the average value of energy along one degree of freedom for an ideal gas in thermal equilibrium at a temperature T ? ( $k_B$  is Boltzmann constant)

**Options :**

86435115725.  $k_B T$

86435115726.  $\frac{1}{2} k_B T$

86435115727.  $\frac{3}{2} k_B T$

$$\frac{2}{3} k_B T$$

86435115728.

**Question Number : 17 Question Id : 8643515237 Question Type : MCQ Option Shuffling : Yes Is Question Mandatory : No**

**Correct Marks : 4 Wrong Marks : 1**

T तापमानास औष्णिक समतोलात आदर्श वायूसाठी एका मुक्तता कोटीसाठी सरासरी ऊर्जेचे मूल्य किती असेल ? ( $k_B$  हा बोल्ट्झमनचा स्थिरांक)

**Options :**

$$k_B T$$

86435115725.

$$\frac{1}{2} k_B T$$

86435115726.

$$\frac{3}{2} k_B T$$

86435115727.

$$\frac{2}{3} k_B T$$

86435115728.

**Question Number : 18 Question Id : 8643515238 Question Type : MCQ Option Shuffling : Yes Is Question Mandatory : No**

**Correct Marks : 4 Wrong Marks : 1**

Match List - I with List - II.

**List - I**

- (a) 10 km height over earth's surface
- (b) 70 km height over earth's surface
- (c) 180 km height over earth's surface
- (d) 270 km height over earth's surface

**List - II**

- (i) Thermosphere
- (ii) Mesosphere
- (iii) Stratosphere
- (iv) Troposphere

**Options :**

86435115729. (a)-(iv), (b)-(iii), (c)-(ii), (d)-(i)

86435115730. (a)-(iii), (b)-(ii), (c)-(i), (d)-(iv)

86435115731. (a)-(ii), (b)-(i), (c)-(iv), (d)-(iii)

86435115732. (a)-(i), (b)-(iv), (c)-(iii), (d)-(ii)

**Question Number : 18 Question Id : 8643515238 Question Type : MCQ Option Shuffling : Yes Is Question Mandatory : No**

**Correct Marks : 4 Wrong Marks : 1**

यादी - I यादी - II बरोबर जुळवा.

यादी - I

यादी - II

- |  |                      |
|--|----------------------|
| (a) पृथ्वीच्या पृष्ठभागाच्या 10 km उंचीवर  | (i) थर्मोस्फिअर      |
| (b) पृथ्वीच्या पृष्ठभागाच्या 70 km उंचीवर  | (ii) मेसोस्फिअर      |
| (c) पृथ्वीच्या पृष्ठभागाच्या 180 km उंचीवर | (iii) स्ट्रेटोस्फिअर |
| (d) पृथ्वीच्या पृष्ठभागाच्या 270 km उंचीवर | (iv) ट्रोपोस्फिअर    |

**Options :**

86435115729. (a)-(iv), (b)-(iii), (c)-(ii), (d)-(i)

86435115730. (a)-(iii), (b)-(ii), (c)-(i), (d)-(iv)

86435115731. (a)-(ii), (b)-(i), (c)-(iv), (d)-(iii)

86435115732. (a)-(i), (b)-(iv), (c)-(iii), (d)-(ii)

**Question Number : 19 Question Id : 8643515239 Question Type : MCQ Option Shuffling : Yes Is Question Mandatory : No**

**Correct Marks : 4 Wrong Marks : 1**

A plane electromagnetic wave of frequency 100 MHz is travelling in vacuum along the  $x$ -direction. At a particular point in space and time,  $\vec{B} = 2.0 \times 10^{-8} \hat{k}$  T. (where,  $\hat{k}$  is unit vector along  $z$ -direction) What is  $\vec{E}$  at this point ?

(speed of light  $c = 3 \times 10^8$  m/s)

**Options :**

86435115733.  $0.6 \hat{j}$  V/m

86435115734.  $6.0 \hat{j}$  V/m

86435115735.  $6.0 \hat{k} \text{ V/m}$

86435115736.  $0.6 \hat{k} \text{ V/m}$

**Question Number : 19 Question Id : 8643515239 Question Type : MCQ Option Shuffling : Yes Is Question Mandatory : No**

**Correct Marks : 4 Wrong Marks : 1**

100 MHz वारंवारतेचा प्रतल विद्युत चुंबकीय तरंग  $x$ -दिशेत निर्वातातून प्रवास करीत आहे. जागा व वेळ मधील एका विशिष्ट बिंदूवर  $\vec{B} = 2.0 \times 10^{-8} \hat{k} \text{ T}$  आहे. (जेथे  $\hat{k}$  हा एकक सदिश  $z$ -दिशेत आहे) त्या बिंदूवर  $\vec{E}$  किती आहे ?

(प्रकाशाचा वेग  $c = 3 \times 10^8 \text{ m/s}$ )

**Options :**

86435115733.  $0.6 \hat{j} \text{ V/m}$

86435115734.  $6.0 \hat{j} \text{ V/m}$

86435115735.  $6.0 \hat{k} \text{ V/m}$

86435115736.  $0.6 \hat{k} \text{ V/m}$

**Question Number : 20 Question Id : 8643515240 Question Type : MCQ Option Shuffling : Yes Is Question Mandatory : No**

**Correct Marks : 4 Wrong Marks : 1**

A thin circular ring of mass  $M$  and radius  $r$  is rotating about its axis with an angular speed  $\omega$ . Two particles having mass  $m$  each are now attached at diametrically opposite points. The angular speed of the ring will become :

**Options :**

86435115737.  $\omega \frac{M}{M + m}$

$$\omega \frac{M}{M + 2m}$$

86435115738.

$$\omega \frac{M - 2m}{M + 2m}$$

86435115739.

$$\omega \frac{M + 2m}{M}$$

86435115740.

**Question Number : 20 Question Id : 8643515240 Question Type : MCQ Option Shuffling : Yes Is Question Mandatory : No**

**Correct Marks : 4 Wrong Marks : 1**

M वस्तुमानाचे व r त्रिज्येचे एक बारीक कडे तिच्या स्वतःच्या अक्षाभोवती  $\omega$  कोनिय वेगाने घूर्णन करीत आहे. प्रत्येकी m वस्तुमानाचे दोन कण व्यासाच्या दोन विरुद्ध बिंदूवर चिकटविले आहेत. कड्याचा कोनिय वेग आता \_\_\_\_\_ होईल.

**Options :**

$$\omega \frac{M}{M + m}$$

86435115737.

$$\omega \frac{M}{M + 2m}$$

86435115738.

$$\omega \frac{M - 2m}{M + 2m}$$

86435115739.

$$\omega \frac{M + 2m}{M}$$

86435115740.

## Physics Section B

<b>Section Id :</b>	864351350
<b>Section Number :</b>	2
<b>Section type :</b>	Online
<b>Mandatory or Optional :</b>	Mandatory
<b>Number of Questions :</b>	10
<b>Number of Questions to be attempted :</b>	5
<b>Section Marks :</b>	20

**Mark As Answered Required? :** Yes  
**Sub-Section Number :** 1  
**Sub-Section Id :** 864351350  
**Question Shuffling Allowed :** Yes

**Question Number : 21 Question Id : 8643515241 Question Type : SA**  
**Correct Marks : 4 Wrong Marks : 0**

An npn transistor operates as a common emitter amplifier with a power gain of  $10^6$ . The input circuit resistance is  $100 \Omega$  and the output load resistance is  $10 \text{ k}\Omega$ . The common emitter current gain ' $\beta$ ' will be \_\_\_\_\_. (Round off to the Nearest Integer)

**Response Type :** Numeric  
**Evaluation Required For SA :** Yes  
**Show Word Count :** Yes  
**Answers Type :** Equal  
**Text Areas :** PlainText  
**Possible Answers :**

100

**Question Number : 21 Question Id : 8643515241 Question Type : SA**  
**Correct Marks : 4 Wrong Marks : 0**

npn ट्रांझिस्टर सामाईक उत्सर्जी प्रवर्धी सारखा  $10^6$  शक्ती वर्धक कार्य करतो. निविष्टी परिपथ रोध  $100 \Omega$  आहे व निष्पन्न भार रोध  $10 \text{ k}\Omega$  आहे. सामाईक उत्सर्जी धारा वर्धन ' $\beta$ ' \_\_\_\_\_ असेल. (जवळच्या पूर्णांकापर्यंत)

**Response Type :** Numeric  
**Evaluation Required For SA :** Yes  
**Show Word Count :** Yes  
**Answers Type :** Equal  
**Text Areas :** PlainText  
**Possible Answers :**

100

**Question Number : 22 Question Id : 8643515242 Question Type : SA**  
**Correct Marks : 4 Wrong Marks : 0**

A ball of mass 10 kg moving with a velocity  $10\sqrt{3}$  m/s along the  $x$ -axis, hits another ball of mass 20 kg which is at rest. After the collision, first ball comes to rest while the second ball disintegrates into two equal pieces. One piece starts moving along  $y$ -axis with a speed of 10 m/s. The second piece starts moving at an angle of  $30^\circ$  with respect to the  $x$ -axis.

The velocity of the ball moving at  $30^\circ$  with  $x$ -axis is  $x$  m/s.

The configuration of pieces after collision is shown in the figure below.

The value of  $x$  to the nearest integer is \_\_\_\_\_.

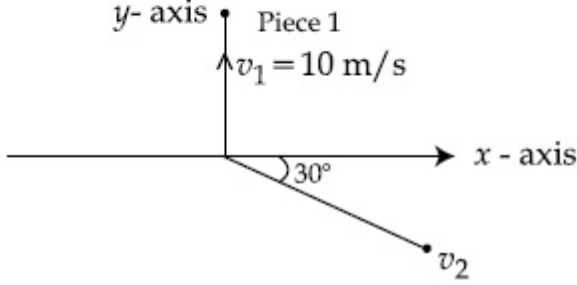

**Response Type :** Numeric

**Evaluation Required For SA :** Yes

**Show Word Count :** Yes

**Answers Type :** Equal

**Text Areas :** PlainText

**Possible Answers :**

100

**Question Number :** 22 **Question Id :** 8643515242 **Question Type :** SA

**Correct Marks :** 4 **Wrong Marks :** 0

10 kg वस्तुमानाचा चेंडू  $10\sqrt{3}$  m/s वेगाने  $x$ -अक्षावर गतिमान असून स्थिर असलेल्या 20 kg वस्तुमानाच्या दूसऱ्या चेंडूवर आपटतो. संघातानंतर, पहिला चेंडू स्थिर होतो तर दूसऱ्या चेंडूचे दोन सारखे तुकडे होतात. एक तुकडा  $y$ -अक्षावर 10 m/s वेगाने गतिमान होतो. दुसरा तुकडा  $x$ -अक्षाशी  $30^\circ$  चा कोन करून गतिमान होतो.  $x$ -अक्षाशी  $30^\circ$  कोन करणाऱ्या चेंडूचा वेग  $x$  m/s आहे. तुकड्यांचे संघातानंतरचे संरूपण खाली आकृतीत दाखविले आहे.  $x$  चे मूल्य जवळच्या पूर्णांकापर्यंत \_\_\_\_\_ आहे.

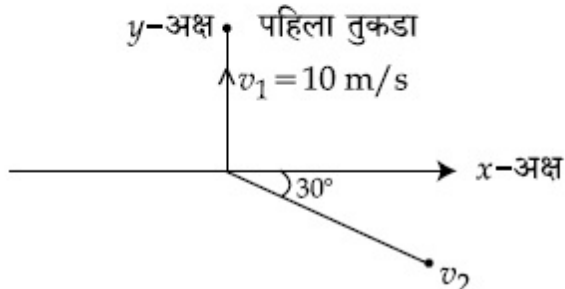

**Response Type :** Numeric

**Evaluation Required For SA :** Yes



Show Word Count : Yes

Answers Type : Equal

Text Areas : PlainText

Possible Answers :

100

Question Number : 23 Question Id : 8643515243 Question Type : SA

Correct Marks : 4 Wrong Marks : 0

The voltage across the  $10\ \Omega$  resistor in the given circuit is  $x$  volt.

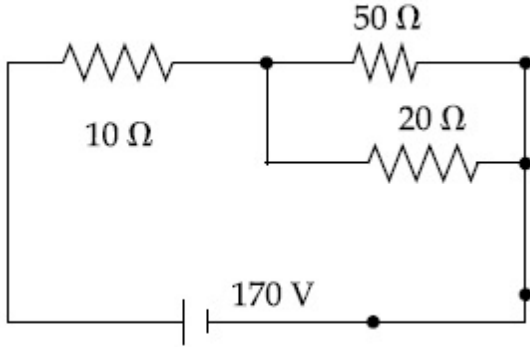

The value of ' $x$ ' to the nearest integer is \_\_\_\_\_.

Response Type : Numeric

Evaluation Required For SA : Yes

Show Word Count : Yes

Answers Type : Equal

Text Areas : PlainText

Possible Answers :

100

Question Number : 23 Question Id : 8643515243 Question Type : SA

Correct Marks : 4 Wrong Marks : 0

दिलेल्या परिपथात  $10\ \Omega$  रोधात व्होल्टता  $x$  व्होल्ट आहे.

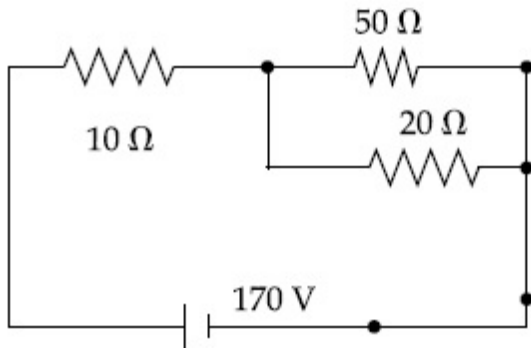

' $x$ ' चे मूल्य जवळच्या पूर्णांकापर्यंत \_\_\_\_\_ आहे.

Response Type : Numeric

**Evaluation Required For SA : Yes**

**Show Word Count : Yes**

**Answers Type : Equal**

**Text Areas : PlainText**

**Possible Answers :**

100

**Question Number : 24 Question Id : 8643515244 Question Type : SA**

**Correct Marks : 4 Wrong Marks : 0**

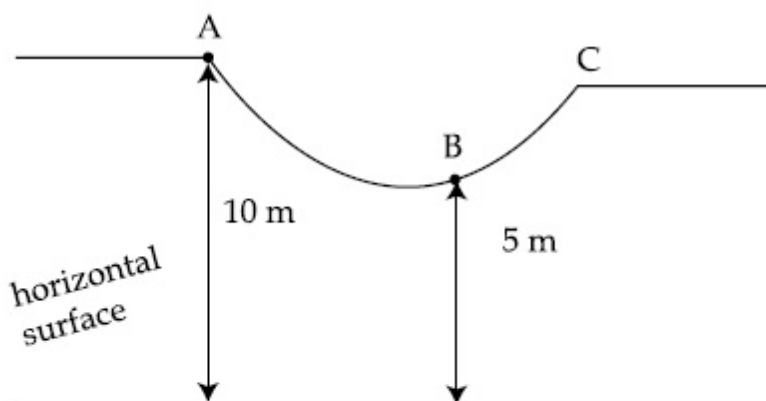

As shown in the figure, a particle of mass 10 kg is placed at a point A. When the particle is slightly displaced to its right, it starts moving and reaches the point B. The speed of the particle at B is  $x$  m/s.

(Take  $g = 10 \text{ m/s}^2$ )

The value of ' $x$ ' to the nearest integer is \_\_\_\_\_.

**Response Type : Numeric**

**Evaluation Required For SA : Yes**

**Show Word Count : Yes**

**Answers Type : Equal**

**Text Areas : PlainText**

**Possible Answers :**

100

**Question Number : 24 Question Id : 8643515244 Question Type : SA**

**Correct Marks : 4 Wrong Marks : 0**

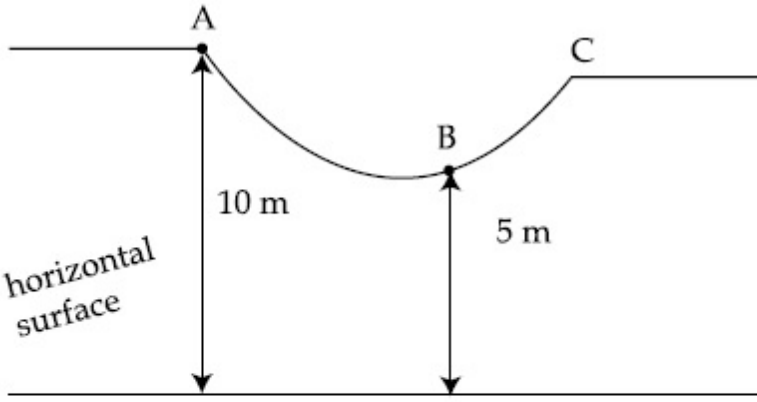

आकृतीत दाखविल्याप्रमाणे, A बिंदूवर 10 kg वस्तुमानाचा एक कण ठेवला आहे. जेव्हा तो कण उजव्या बाजूस थोडासा सरकविला, तो गतिमान होतो व B बिंदूवर पोहोचतो. कणाचा वेग B बिंदूपाशी  $x$  m/s आहे.

(घ्या  $g = 10 \text{ m/s}^2$ )

' $x$ ' चे मूल्य जवळच्या पूर्णांकापर्यंत \_\_\_\_\_ आहे.

**Response Type :** Numeric

**Evaluation Required For SA :** Yes

**Show Word Count :** Yes

**Answers Type :** Equal

**Text Areas :** PlainText

**Possible Answers :**

100

**Question Number :** 25 **Question Id :** 8643515245 **Question Type :** SA

**Correct Marks :** 4 **Wrong Marks :** 0

A particle performs simple harmonic motion with a period of 2 second. The time taken by the particle to cover a displacement equal to half of its amplitude from the mean position is

$\frac{1}{a}$  s.

The value of 'a' to the nearest integer is \_\_\_\_\_.

**Response Type :** Numeric

**Evaluation Required For SA :** Yes

**Show Word Count :** Yes

**Answers Type :** Equal

**Text Areas :** PlainText

**Possible Answers :**

100

**Question Number :** 25 **Question Id :** 8643515245 **Question Type :** SA

**Correct Marks :** 4 **Wrong Marks :** 0

एक कण 2 सेकंद कालाने सरल आवर्त गतित जातो. मध्य स्थितीपासून अर्ध्या आयामापर्यंत विस्थापन होण्यासाठी

कणाने घेतलेला वेळ  $\frac{1}{a}$  s आहे.

'a' चे मूल्य जवळच्या पूर्णांकापर्यंत \_\_\_\_\_ आहे.

**Response Type :** Numeric

**Evaluation Required For SA :** Yes

**Show Word Count :** Yes

**Answers Type :** Equal

**Text Areas :** PlainText

**Possible Answers :**

100

**Question Number :** 26 **Question Id :** 8643515246 **Question Type :** SA

**Correct Marks :** 4 **Wrong Marks :** 0

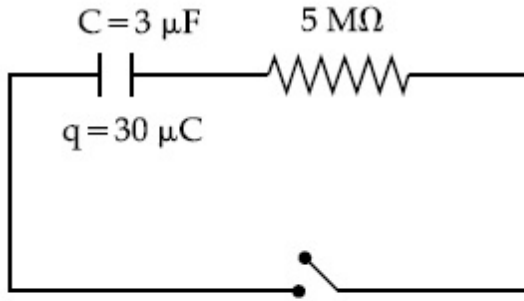

The circuit shown in the figure consists of a charged capacitor of capacity  $3 \mu\text{F}$  and a charge of  $30 \mu\text{C}$ . At time  $t=0$ , when the key is closed, the value of current flowing through the  $5 \text{ M}\Omega$  resistor is ' $x$ '  $\mu\text{A}$ .

The value of ' $x$ ' to the nearest integer is \_\_\_\_\_.

**Response Type :** Numeric

**Evaluation Required For SA :** Yes

**Show Word Count :** Yes

**Answers Type :** Equal

**Text Areas :** PlainText

**Possible Answers :**

100

**Question Number :** 26 **Question Id :** 8643515246 **Question Type :** SA

**Correct Marks :** 4 **Wrong Marks :** 0

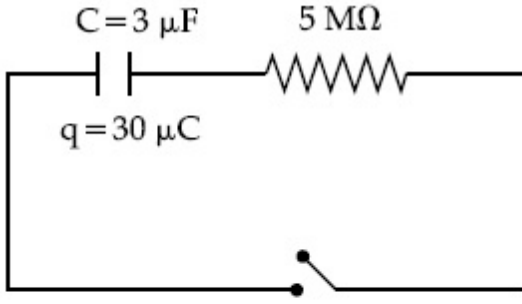

आकृतीत दाखविलेल्या परिपथात  $3 \mu\text{F}$  धारकतेचे प्रभारित संधारित्र व  $30 \mu\text{C}$  प्रभार आहे.  $t=0$  असताना, जेव्हा कळ दाबली,  $5 \text{ M}\Omega$  रोधातून वाहणाऱ्या धारेचे मूल्य ' $x$ '  $\mu\text{A}$  आहे.

' $x$ ' चे मूल्य जवळच्या पूर्णांकापर्यंत \_\_\_\_\_ आहे.

**Response Type :** Numeric

**Evaluation Required For SA :** Yes

**Show Word Count :** Yes

**Answers Type :** Equal

**Text Areas :** PlainText

**Possible Answers :**

100

**Question Number :** 27 **Question Id :** 8643515247 **Question Type :** SA

**Correct Marks :** 4 **Wrong Marks :** 0

A person is swimming with a speed of  $10 \text{ m/s}$  at an angle of  $120^\circ$  with the flow and reaches to a point directly opposite on the other side of the river. The speed of the flow is ' $x$ '  $\text{m/s}$ .

The value of ' $x$ ' to the nearest integer is \_\_\_\_\_.

**Response Type :** Numeric

**Evaluation Required For SA :** Yes

**Show Word Count :** Yes

**Answers Type :** Equal

**Text Areas :** PlainText

**Possible Answers :**

100

**Question Number :** 27 **Question Id :** 8643515247 **Question Type :** SA

**Correct Marks :** 4 **Wrong Marks :** 0

एक माणूस प्रवाहाशी  $120^\circ$  कोनातून  $10 \text{ m/s}$  वेगाने पोहोतो व नदीच्या दूसऱ्या विरुद्ध बाजूच्या बिंदूवर पोहोचतो.

प्रवाहाचा वेग ' $x$ '  $\text{m/s}$  आहे. ' $x$ ' चे मूल्य जवळच्या पूर्णांकापर्यंत \_\_\_\_\_ आहे.

**Response Type :** Numeric

**Evaluation Required For SA :** Yes

**Show Word Count :** Yes

**Answers Type :** Equal

**Text Areas :** PlainText

**Possible Answers :**

100

**Question Number : 28 Question Id : 8643515248 Question Type : SA**

**Correct Marks : 4 Wrong Marks : 0**

Two separate wires A and B are stretched by 2 mm and 4 mm respectively, when they are subjected to a force of 2 N. Assume that both the wires are made up of same material and the radius of wire B is 4 times that of the radius of wire A. The length of the wires A and B

are in the ratio of  $a : b$ . Then  $\frac{a}{b}$  can be expressed as  $\frac{1}{x}$  where  $x$  is \_\_\_\_\_.

**Response Type :** Numeric

**Evaluation Required For SA :** Yes

**Show Word Count :** Yes

**Answers Type :** Equal

**Text Areas :** PlainText

**Possible Answers :**

100

**Question Number : 28 Question Id : 8643515248 Question Type : SA**

**Correct Marks : 4 Wrong Marks : 0**

दोन वेगवेगळ्या तारा A व B ह्या अनुक्रमे 2 mm व 4 mm ने ताणल्या, जेव्हा त्यावर 2 N चे बल लावले. असे माना कि तारा एकाच पदार्थापासून बनविल्या आहेत व B तारेची त्रिज्या A तारेच्या त्रिज्येच्या चारपट आहे.

A व B तारांच्या लांबीचे गुणोत्तर  $a : b$  आहे, तर  $\frac{a}{b}$  हे  $\frac{1}{x}$  असे दर्शविले जाते जेथे  $x$  \_\_\_\_\_ आहे.

**Response Type :** Numeric

**Evaluation Required For SA :** Yes

**Show Word Count :** Yes

**Answers Type :** Equal

**Text Areas :** PlainText

**Possible Answers :**

100

**Question Number : 29 Question Id : 8643515249 Question Type : SA**

**Correct Marks : 4 Wrong Marks : 0**

A parallel plate capacitor has plate area  $100 \text{ m}^2$  and plate separation of  $10 \text{ m}$ . The space between the plates is filled up to a thickness  $5 \text{ m}$  with a material of dielectric constant of  $10$ . The resultant capacitance of the system is ' $x$ ' pF.

The value of  $\epsilon_0 = 8.85 \times 10^{-12} \text{ F.m}^{-1}$

The value of ' $x$ ' to the nearest integer is \_\_\_\_\_.

**Response Type :** Numeric

**Evaluation Required For SA :** Yes

**Show Word Count :** Yes

**Answers Type :** Equal

**Text Areas :** PlainText

**Possible Answers :**

100

**Question Number :** 29 **Question Id :** 8643515249 **Question Type :** SA

**Correct Marks :** 4 **Wrong Marks :** 0

एका समांतर पट्टी संधारित्राच्या पट्ट्यांचे क्षेत्रफळ  $100 \text{ m}^2$  आहे व पट्टी अंतराल  $10 \text{ m}$  आहे. पट्ट्यांमधील  $5 \text{ m}$  जाडीपर्यंत जागा  $10$  पराविद्युत स्थिरांक असलेल्या पदार्थाने पूर्ण भरली. संहतीची परिणामी धारकता ' $x$ ' pF आहे.

$\epsilon_0$  चे मूल्य  $\epsilon_0 = 8.85 \times 10^{-12} \text{ F.m}^{-1}$

' $x$ ' चे मूल्य जवळच्या पूर्णांकापर्यंत \_\_\_\_\_ आहे. (जवळच्या पूर्णांकापर्यंत)

**Response Type :** Numeric

**Evaluation Required For SA :** Yes

**Show Word Count :** Yes

**Answers Type :** Equal

**Text Areas :** PlainText

**Possible Answers :**

100

**Question Number :** 30 **Question Id :** 8643515250 **Question Type :** SA

**Correct Marks :** 4 **Wrong Marks :** 0

A bullet of mass  $0.1 \text{ kg}$  is fired on a wooden block to pierce through it, but it stops after moving a distance of  $50 \text{ cm}$  into it. If the velocity of bullet before hitting the wood is  $10 \text{ m/s}$  and it slows down with uniform deceleration, then the magnitude of effective retarding force on the bullet is ' $x$ ' N.

The value of ' $x$ ' to the nearest integer is \_\_\_\_\_.

**Response Type :** Numeric

**Evaluation Required For SA :** Yes

**Show Word Count :** Yes

**Answers Type :** Equal

**Text Areas :** PlainText

**Possible Answers :**

100

**Question Number : 30 Question Id : 8643515250 Question Type : SA**

**Correct Marks : 4 Wrong Marks : 0**

0.1 kg वस्तुमानाची एक गोळी लाकडाच्या ठोकळ्यावर झाडली कि ती त्यातून बाहेर जाईल पण ती 50 cm अंतर गेल्यानंतर थांबली. जर गोळीचा वेग लाकडावर आपटण्यापूर्वी 10 m/s आहे व ती एकसमान अवत्तरणाने मंद होते तर गोळीवर परिणामी मंदन बलाची किंमत 'x' N आहे.

'x' चे मूल्य जवळच्या पूर्णांकापर्यंत \_\_\_\_\_ आहे.

**Response Type :** Numeric

**Evaluation Required For SA :** Yes

**Show Word Count :** Yes

**Answers Type :** Equal

**Text Areas :** PlainText

**Possible Answers :**

100

## Chemistry Section A

<b>Section Id :</b>	864351351
<b>Section Number :</b>	3
<b>Section type :</b>	Online
<b>Mandatory or Optional :</b>	Mandatory
<b>Number of Questions :</b>	20
<b>Number of Questions to be attempted :</b>	20
<b>Section Marks :</b>	80
<b>Mark As Answered Required? :</b>	Yes
<b>Sub-Section Number :</b>	1
<b>Sub-Section Id :</b>	864351351
<b>Question Shuffling Allowed :</b>	Yes

**Question Number : 31 Question Id : 8643515251 Question Type : MCQ Option Shuffling : Yes Is**

**Question Mandatory : No**

**Correct Marks : 4 Wrong Marks : 1**

In a binary compound, atoms of element A form a hcp structure and those of element M occupy 2/3 of the tetrahedral voids of the hcp structure. The formula of the binary compound is :

**Options :**

86435115751.  $M_2A_3$



86435115752.  $M_4A_3$ 86435115753.  $MA_3$ 86435115754.  $M_4A$ **Question Number : 31 Question Id : 8643515251 Question Type : MCQ Option Shuffling : Yes Is****Question Mandatory : No****Correct Marks : 4 Wrong Marks : 1**

एका द्विअंगी संयुगात, मूलद्रव्य A चे अणू hcp संरचना तयार करतात तर मूलद्रव्य M हे  $2/3$  चतुष्पृष्ठी पोकळ्यात थांबतात. त्या hcp संरचनेतील त्या द्विअंगी संयुगाचे सूत्र \_\_\_\_\_ आहे.

**Options :**86435115751.  $M_2A_3$ 86435115752.  $M_4A_3$ 86435115753.  $MA_3$ 86435115754.  $M_4A$ **Question Number : 32 Question Id : 8643515252 Question Type : MCQ Option Shuffling : Yes Is****Question Mandatory : No****Correct Marks : 4 Wrong Marks : 1**

A certain orbital has no angular nodes and two radial nodes. The orbital is :

**Options :**86435115755.  $2s$ 86435115756.  $2p$ 86435115757.  $3s$ 86435115758.  $3p$ **Question Number : 32 Question Id : 8643515252 Question Type : MCQ Option Shuffling : Yes Is**

**Question Mandatory : No**

**Correct Marks : 4 Wrong Marks : 1**

एका विशिष्ट कक्षिकेसाठी कोनीय नोड नाही आणि दोन अरिय नोड्स आहेत. तर ती कक्षिका \_\_\_\_\_ आहे.

**Options :**

86435115755. 2s

86435115756. 2p

86435115757. 3s

86435115758. 3p

**Question Number : 33 Question Id : 8643515253 Question Type : MCQ Option Shuffling : Yes Is Question Mandatory : No**

**Correct Marks : 4 Wrong Marks : 1**

**Match List - I with List - II :**

List - I (Process)	List - II (Catalyst)
(a) Deacon's process	(i) ZSM-5
(b) Contact process	(ii) $\text{CuCl}_2$
(c) Cracking of hydrocarbons	(iii) Particles 'Ni'
(d) Hydrogenation of vegetable oils	(iv) $\text{V}_2\text{O}_5$

Choose the most appropriate answer from the options given below :

**Options :**

86435115759. (a)-(i), (b)-(iii), (c)-(ii), (d)-(iv)

86435115760. (a)-(iv), (b)-(ii), (c)-(i), (d)-(iii)

86435115761. (a)-(iii), (b)-(i), (c)-(iv), (d)-(ii)

86435115762. (a)-(ii), (b)-(iv), (c)-(i), (d)-(iii)

**Question Number : 33 Question Id : 8643515253 Question Type : MCQ Option Shuffling : Yes Is Question Mandatory : No**

**Correct Marks : 4 Wrong Marks : 1**

यादी - I यादी - II बरोबर जुळवा.

यादी - I (प्रक्रिया)	यादी - II (उत्प्रेरक)
(a) डेकान्सची प्रक्रिया	(i) ZSM-5
(b) कॉन्टॅक्ट प्रक्रिया	(ii) $\text{CuCl}_2$
(c) हायड्रोकार्बनचे भंजन	(iii) 'Ni' चे कण
(d) वनस्पती तेलाचे हायड्रोजिनेशन	(iv) $\text{V}_2\text{O}_5$

खालील पर्यायांमधून बरोबर उत्तर निवडा.

**Options :**

86435115759. (a)-(i), (b)-(iii), (c)-(ii), (d)-(iv)

86435115760. (a)-(iv), (b)-(ii), (c)-(i), (d)-(iii)

86435115761. (a)-(iii), (b)-(i), (c)-(iv), (d)-(ii)

86435115762. (a)-(ii), (b)-(iv), (c)-(i), (d)-(iii)

**Question Number : 34 Question Id : 8643515254 Question Type : MCQ Option Shuffling : Yes Is Question Mandatory : No**

**Correct Marks : 4 Wrong Marks : 1**

The ionic radius of  $\text{Na}^+$  ion is  $1.02 \text{ \AA}$ . The ionic radii (in  $\text{ \AA}$ ) of  $\text{Mg}^{2+}$  and  $\text{Al}^{3+}$ , respectively, are :

**Options :**

86435115763. 0.85 and 0.99

86435115764. 0.72 and 0.54

86435115765. 0.68 and 0.72

86435115766. 1.05 and 0.99

**Question Number : 34 Question Id : 8643515254 Question Type : MCQ Option Shuffling : Yes Is**

**Question Mandatory : No**

**Correct Marks : 4 Wrong Marks : 1**

$\text{Na}^+$  आयनाची आयनन त्रिज्या  $1.02 \text{ \AA}$  आहे.  $\text{Mg}^{2+}$  आणि  $\text{Al}^{3+}$  ह्यांच्या ( $\text{Å}$  मधील) अनुक्रमे आयनन त्रिज्या \_\_\_\_\_ आहेत.

**Options :**

86435115763. 0.85 आणि 0.99

86435115764. 0.72 आणि 0.54

86435115765. 0.68 आणि 0.72

86435115766. 1.05 आणि 0.99

**Question Number : 35 Question Id : 8643515255 Question Type : MCQ Option Shuffling : Yes Is**

**Question Mandatory : No**

**Correct Marks : 4 Wrong Marks : 1**

The chemical that is added to reduce the melting point of the reaction mixture during the extraction of aluminium is :

**Options :**

86435115767. Bauxite

86435115768. Kaolite

86435115769. Calamine

86435115770. Cryolite

**Question Number : 35 Question Id : 8643515255 Question Type : MCQ Option Shuffling : Yes Is**

**Question Mandatory : No**

**Correct Marks : 4 Wrong Marks : 1**

अॅल्युमिनिअमच्या निष्कर्षण क्रियेतील मिश्रणाचा द्रवणांक कमी करण्यासाठी घालण्यात येणारे रसायन \_\_\_\_\_ आहे.

**Options :**

86435115767. बॉक्साइट

86435115768. केओलाइट

86435115769. कॅलामाइन

86435115770. क्रायोलाइट

**Question Number : 36 Question Id : 8643515256 Question Type : MCQ Option Shuffling : Yes Is Question Mandatory : No**

**Correct Marks : 4 Wrong Marks : 1**

Given below are two Statements : One is labelled as Assertion A and the other is labelled as Reason R :

**Assertion A :** During the boiling of water having temporary hardness,  $Mg(HCO_3)_2$  is converted to  $MgCO_3$ .

**Reason R :** The solubility product of  $Mg(OH)_2$  is greater than that of  $MgCO_3$ .

In the light of the above statements, choose the most appropriate answer from the options given below :

**Options :**

86435115771. Both A and R are true and R is the correct explanation of A

86435115772. Both A and R are true but R is NOT the correct explanation of A

86435115773. A is true but R is false

86435115774. A is false but R is true

**Question Number : 36 Question Id : 8643515256 Question Type : MCQ Option Shuffling : Yes Is Question Mandatory : No**

**Correct Marks : 4 Wrong Marks : 1**

खाली दोन विधाने दिलेली आहेत. एक कथन A आणि दूसरे कारण R असे लिहिलेले आहे.

**कथन A :** तात्पुरती दुष्फेनता असलेल्या पाण्याला उकळताना  $Mg(HCO_3)_2$  चे  $MgCO_3$  मध्ये रूपांतर होते.

**कारण R :**  $Mg(OH)_2$  चे द्रावणीयता गुणन फल  $MgCO_3$  पेक्षा जास्त आहे.

वरील विधानांस अनुसरून खालील पर्यायांमधून बरोबर उत्तर निवडा.

**Options :**

86435115771. दोन्ही A आणि R खरे आहेत आणि R हे A चे बरोबर स्पष्टीकरण आहे.

86435115772. दोन्ही A आणि R खरे आहेत परंतु R हे A चे बरोबर स्पष्टीकरण नाही.

86435115773. A खरे आहे परंतु R खोटे आहे.

86435115774. A खोटे आहे परंतु R खरे आहे.

**Question Number : 37 Question Id : 8643515257 Question Type : MCQ Option Shuffling : Yes Is Question Mandatory : No**

**Correct Marks : 4 Wrong Marks : 1**

**Match List - I with List - II :**

List - I	List - II
(a) $\text{Ca(OCl)}_2$	(i) Antacid
(b) $\text{CaSO}_4 \cdot \frac{1}{2}\text{H}_2\text{O}$	(ii) Cement
(c) $\text{CaO}$	(iii) Bleach
(d) $\text{CaCO}_3$	(iv) Plaster of Paris

Choose the most appropriate answer from the options given below :

**Options :**

86435115775. (a)-(i), (b)-(iv), (c)-(iii), (d)-(ii)

86435115776. (a)-(iii), (b)-(ii), (c)-(i), (d)-(iv)

86435115777. (a)-(iii), (b)-(ii), (c)-(iv), (d)-(i)

86435115778. (a)-(iii), (b)-(iv), (c)-(ii), (d)-(i)

**Question Number : 37 Question Id : 8643515257 Question Type : MCQ Option Shuffling : Yes Is Question Mandatory : No**

**Correct Marks : 4 Wrong Marks : 1**

यादी - I यादी - II बरोबर जुळवा.

यादी - I	यादी - II
(a) $\text{Ca(OCl)}_2$	(i) प्रतिआम्ल (Antacid)
(b) $\text{CaSO}_4 \cdot \frac{1}{2}\text{H}_2\text{O}$	(ii) सिमेंट
(c) $\text{CaO}$	(iii) ब्लीच
(d) $\text{CaCO}_3$	(iv) प्लास्टर ऑफ पॅरिस

खालील पर्यायांमधून योग्य उत्तर निवडा.

**Options :**

86435115775. (a)-(i), (b)-(iv), (c)-(iii), (d)-(ii)

86435115776. (a)-(iii), (b)-(ii), (c)-(i), (d)-(iv)

86435115777. (a)-(iii), (b)-(ii), (c)-(iv), (d)-(i)

86435115778. (a)-(iii), (b)-(iv), (c)-(ii), (d)-(i)

**Question Number : 38 Question Id : 8643515258 Question Type : MCQ Option Shuffling : Yes Is Question Mandatory : No**

**Correct Marks : 4 Wrong Marks : 1**

The number of ionisable hydrogens present in the product obtained from a reaction of phosphorus trichloride and phosphonic acid is :

**Options :**

86435115779. 1

86435115780. 2

86435115781. 0

86435115782. 3

**Question Number : 38 Question Id : 8643515258 Question Type : MCQ Option Shuffling : Yes Is Question Mandatory : No**

**Correct Marks : 4 Wrong Marks : 1**

फॉस्फरस ट्रायक्लोराइड आणि फॉस्फोनिक आम्ल ह्यांच्या अभिक्रियेतून तयार होणाऱ्या उत्पादातील आयनन होणाऱ्या हायड्रोजनसूची संख्या \_\_\_\_\_ आहे.

**Options :**

86435115779. <sup>1</sup>

86435115780. <sup>2</sup>

86435115781. <sup>0</sup>

86435115782. <sup>3</sup>

**Question Number : 39 Question Id : 8643515259 Question Type : MCQ Option Shuffling : Yes Is Question Mandatory : No**

**Correct Marks : 4 Wrong Marks : 1**

**Match List - I with List - II :**

List - I	List - II
(a) Chlorophyll	(i) Ruthenium
(b) Vitamin - B <sub>12</sub>	(ii) Platinum
(c) Anticancer drug	(iii) Cobalt
(d) Grubbs catalyst	(iv) Magnesium

Choose the most appropriate answer from the options given below :

**Options :**

86435115783. (a)-(iii), (b)-(ii), (c)-(iv), (d)-(i)

86435115784. (a)-(iv), (b)-(iii), (c)-(ii), (d)-(i)

86435115785. (a)-(iv), (b)-(ii), (c)-(iii), (d)-(i)

86435115786. (a)-(iv), (b)-(iii), (c)-(i), (d)-(ii)

**Question Number : 39 Question Id : 8643515259 Question Type : MCQ Option Shuffling : Yes Is Question Mandatory : No**

**Correct Marks : 4 Wrong Marks : 1**



यादी - I यादी - II बरोबर जुळवा.

यादी - I	यादी - II
(a) क्लोरोफिल	(i) रुथेनियम
(b) जीवनसत्व - B <sub>12</sub>	(ii) प्लॅटिनम
(c) प्रतिकँसर औषध	(iii) कोबाल्ट
(d) ग्रब्ज उत्प्रेरक	(iv) मॅग्नेशियम

खालील पर्यायांमधून योग्य उत्तर निवडा.

Options :

86435115783. (a)-(iii), (b)-(ii), (c)-(iv), (d)-(i)

86435115784. (a)-(iv), (b)-(iii), (c)-(ii), (d)-(i)

86435115785. (a)-(iv), (b)-(ii), (c)-(iii), (d)-(i)

86435115786. (a)-(iv), (b)-(iii), (c)-(i), (d)-(ii)

Question Number : 40 Question Id : 8643515260 Question Type : MCQ Option Shuffling : Yes Is Question Mandatory : No

Correct Marks : 4 Wrong Marks : 1

The correct structures of trans-[NiBr<sub>2</sub>(PPh<sub>3</sub>)<sub>2</sub>] and meridional-[Co(NH<sub>3</sub>)<sub>3</sub>(NO<sub>2</sub>)<sub>3</sub>], respectively, are :

Options :

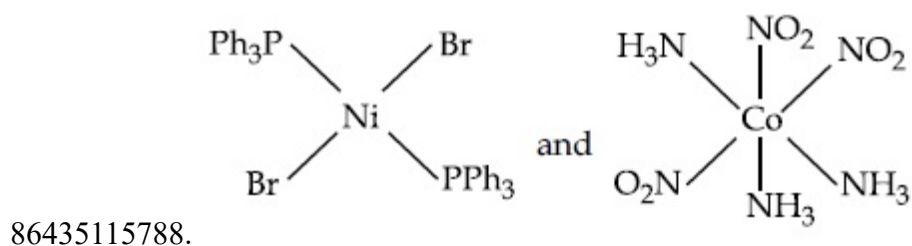
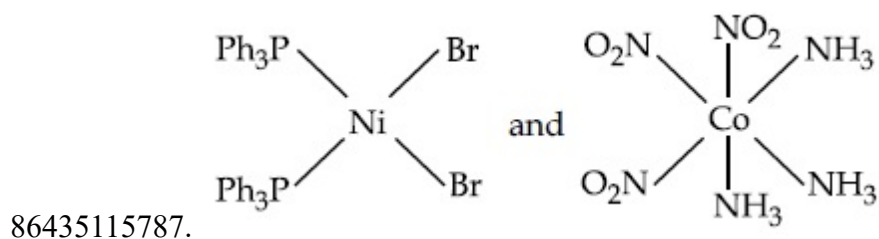

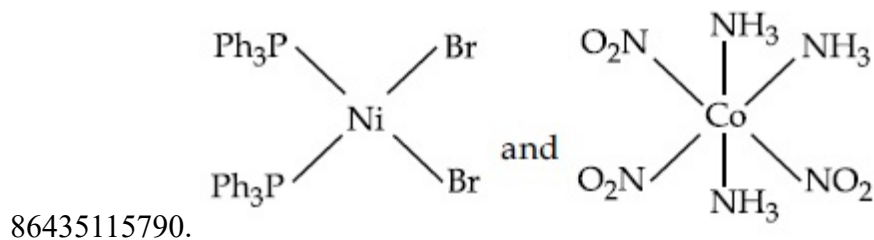
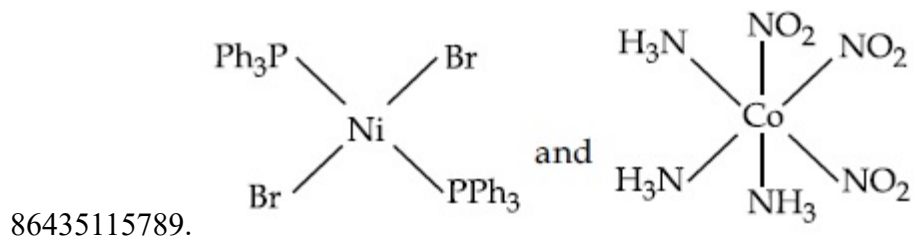

**Question Number : 40 Question Id : 8643515260 Question Type : MCQ Option Shuffling : Yes Is Question Mandatory : No**

**Correct Marks : 4 Wrong Marks : 1**

ट्रान्स- $[\text{NiBr}_2(\text{PPh}_3)_2]$  आणि मेरिडोनिअल- $[\text{Co}(\text{NH}_3)_3(\text{NO}_2)_3]$  ह्यांच्या बरोबर संरचना अनुक्रमे \_\_\_\_\_ आहेत.

**Options :**

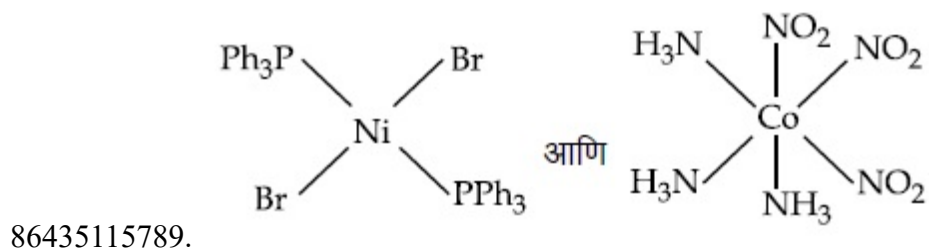
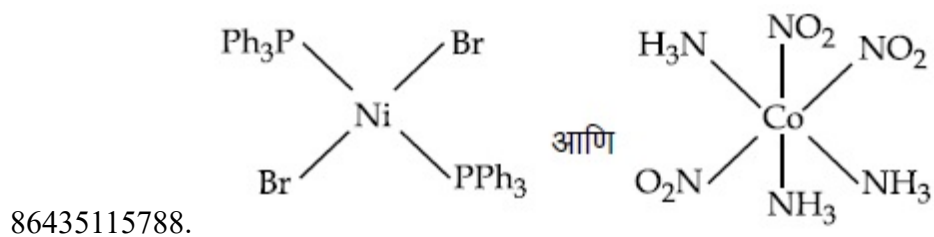
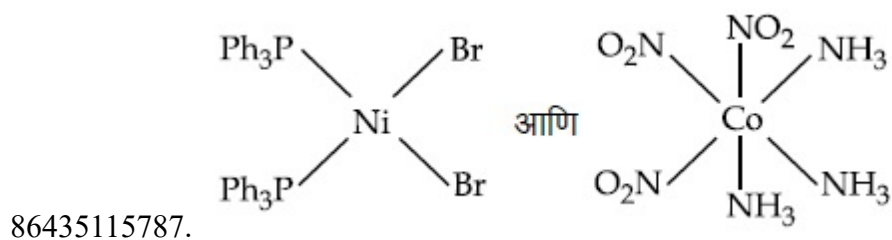

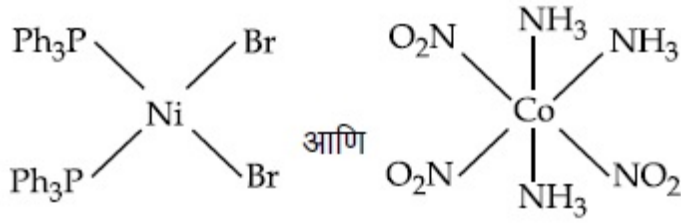

86435115790.

**Question Number : 41 Question Id : 8643515261 Question Type : MCQ Option Shuffling : Yes Is Question Mandatory : No**

**Correct Marks : 4 Wrong Marks : 1**

The statements that are TRUE :

- (A) methane leads to both global warming and photochemical smog
- (B) methane is generated from paddy fields
- (C) methane is a stronger global warming gas than CO<sub>2</sub>
- (D) methane is a part of reducing smog.

Choose the most appropriate answer from the options given below :

**Options :**

86435115791. (A) and (B) only

86435115792. (A), (B), (C) only

86435115793. (B), (C), (D) only

86435115794. (A), (B), (D) only

**Question Number : 41 Question Id : 8643515261 Question Type : MCQ Option Shuffling : Yes Is Question Mandatory : No**

**Correct Marks : 4 Wrong Marks : 1**

जी विधाने खरी आहेत ती :

- (A) मिथेन मुळे ग्लोबल वॉर्मिंग आणि प्रकाशरासायनिक धूहार होतो.
- (B) मिथेन साळीच्या शेतात तयार होतो.
- (C) CO<sub>2</sub> पेक्षा मिथेन शक्तिवान ग्लोबल वॉर्मिंग वायू आहे.
- (D) मिथेन हा क्षपणकारी धूहाराचा भाग आहे.

खालील पर्यायांमधून योग्य उत्तर निवडा.

**Options :**

86435115791. (A) आणि (B) फक्त

86435115792. (A), (B), (C) फक्त

86435115793. (B), (C), (D) फक्त

86435115794. (A), (B), (D) फक्त

**Question Number : 42 Question Id : 8643515262 Question Type : MCQ Option Shuffling : Yes Is**

**Question Mandatory : No**

**Correct Marks : 4 Wrong Marks : 1**

Compound with molecular formula  $C_3H_6O$  can show :

**Options :**

86435115795. Positional isomerism

86435115796. Functional group isomerism

86435115797. Metamerism

86435115798. Both positional isomerism and metamerism

**Question Number : 42 Question Id : 8643515262 Question Type : MCQ Option Shuffling : Yes Is**

**Question Mandatory : No**

**Correct Marks : 4 Wrong Marks : 1**

$C_3H_6O$  हे रेणु सूत्र असलेले संयुग \_\_\_\_\_ दाखवु शकते.

**Options :**

86435115795. स्थान समसूत्रता

86435115796. क्रियात्मक गट समसूत्रता

86435115797. वर्गीय समसूत्रता

86435115798. दोन्ही स्थान आणि वर्गीय समसूत्रता

Question Number : 43 Question Id : 8643515263 Question Type : MCQ Option Shuffling : Yes Is Question Mandatory : No

Correct Marks : 4 Wrong Marks : 1

Match List - I with List - II :

List - I

(Chemicals)

- (a) Alcoholic potassium hydroxide  
 (b) Pd/BaSO<sub>4</sub>  
 (c) BHC (Benzene hexachloride)  
 (d) Polyacetylene

List - II

(Use/Preparation/Constituent)

- (i) electrodes in batteries  
 (ii) obtained by addition reaction  
 (iii) used for  $\beta$ -elimination reaction  
 (iv) Lindlar's Catalyst

Choose the most appropriate match :

Options :

86435115799. (a)-(ii), (b)-(i), (c)-(iv), (d)-(iii)

86435115800. (a)-(iii), (b)-(i), (c)-(iv), (d)-(ii)

86435115801. (a)-(ii), (b)-(iv), (c)-(i), (d)-(iii)

86435115802. (a)-(iii), (b)-(iv), (c)-(ii), (d)-(i)

Question Number : 43 Question Id : 8643515263 Question Type : MCQ Option Shuffling : Yes Is Question Mandatory : No

Correct Marks : 4 Wrong Marks : 1

यादी - I यादी - II बरोबर जुळवा.

यादी - I

(रसायने)

- (a) पोटॅशियम हायड्रॉक्साइड अल्कोहोल मधील  
 (b) Pd/BaSO<sub>4</sub>  
 (c) BHC (बेंझिन हेक्साक्लोराइड)  
 (d) पॉलिअॅसिटिलिन

यादी - II

(उपयोग/तयार करणे/घटक)

- (i) बॅटरीतील इलेक्ट्रोड  
 (ii) समावेशी अभिक्रियेतून मिळते  
 (iii)  $\beta$ -विलोपन अभिक्रियेत वापरतात  
 (iv) लिंडलरचा उत्प्रेरक

योग्य जोडीचा पर्याय निवडा.

Options :

86435115799. (a)-(ii), (b)-(i), (c)-(iv), (d)-(iii)

86435115800. (a)-(iii), (b)-(i), (c)-(iv), (d)-(ii)

86435115801. (a)-(ii), (b)-(iv), (c)-(i), (d)-(iii)

86435115802. (a)-(iii), (b)-(iv), (c)-(ii), (d)-(i)

**Question Number : 44 Question Id : 8643515264 Question Type : MCQ Option Shuffling : Yes Is Question Mandatory : No**

**Correct Marks : 4 Wrong Marks : 1**

Reaction of Grignard reagent,  $C_2H_5MgBr$  with  $C_8H_8O$  followed by hydrolysis gives compound "A" which reacts instantly with Lucas reagent to give compound B,  $C_{10}H_{13}Cl$ .

The Compound B is :

Options :

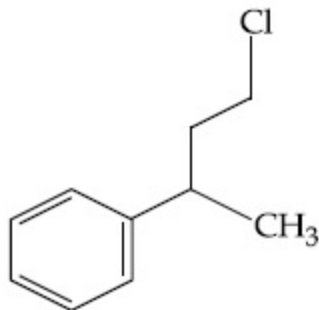

86435115803.

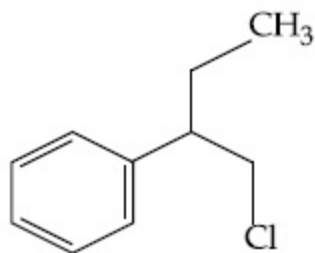

86435115804.

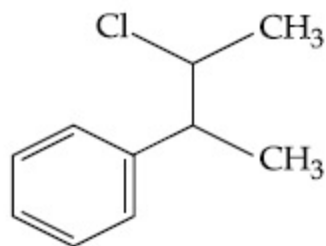

86435115805.

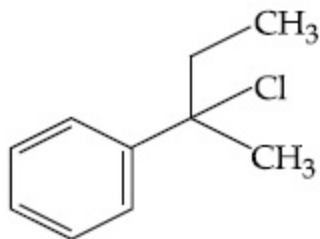

86435115806.

Question Number : 44 Question Id : 8643515264 Question Type : MCQ Option Shuffling : Yes Is Question Mandatory : No

Correct Marks : 4 Wrong Marks : 1

$C_8H_8O$  ह्या संयुगाची ग्रिगनार्ड अभिक्रियाकारक  $C_2H_5MgBr$  सोबत अभिक्रिया केली नंतर जलीय अपघटन केले असता संयुग "A" तयार होते जे ल्युकास अभिक्रियाकारकाबरोबर क्षणात क्रिया करून संयुग B,  $C_{10}H_{13}Cl$  देतो.

संयुग B \_\_\_\_\_ आहे.

Options :

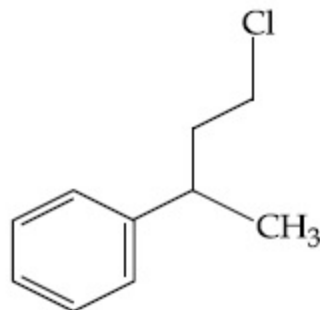

86435115803.

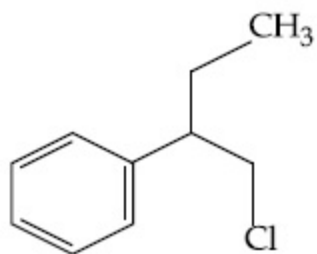

86435115804.

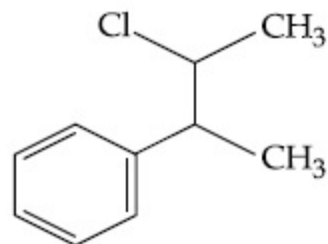

86435115805.

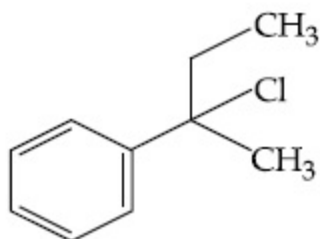

86435115806.

Question Number : 45 Question Id : 8643515265 Question Type : MCQ Option Shuffling : Yes Is Question Mandatory : No

Correct Marks : 4 Wrong Marks : 1

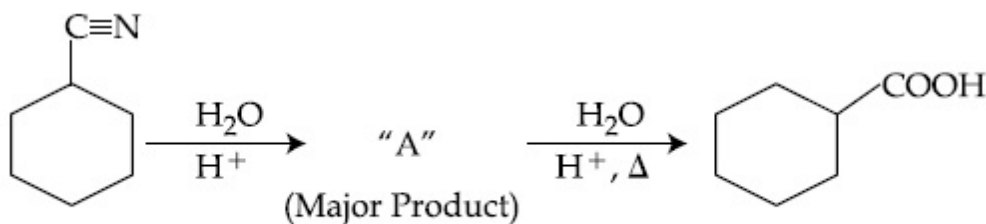

Consider the above chemical reaction and identify product "A" :

Options :

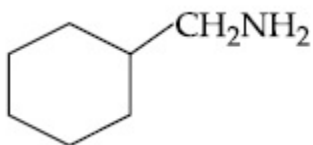

86435115807.

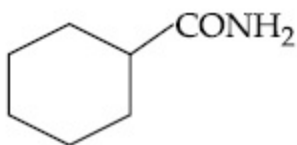

86435115808.

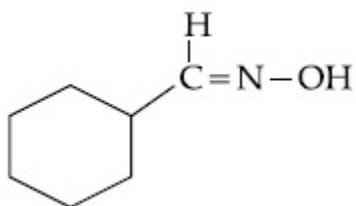

86435115809.

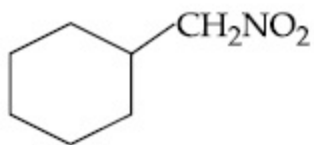

86435115810.

Question Number : 45 Question Id : 8643515265 Question Type : MCQ Option Shuffling : Yes Is



**Question Mandatory : No**

**Correct Marks : 4 Wrong Marks : 1**

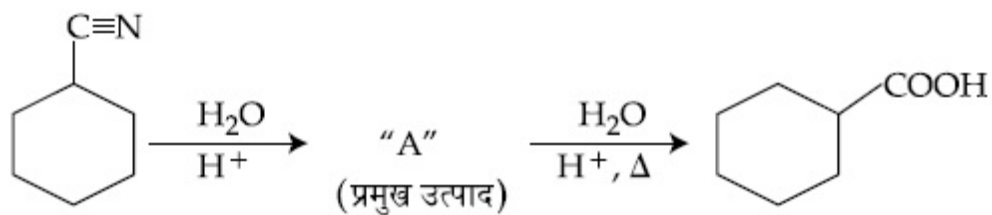

वरील अभिक्रिया लक्षात घ्या आणि उत्पाद "A" ओळखा.

**Options :**

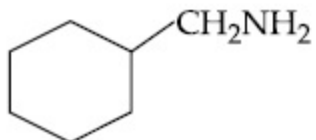

86435115807.

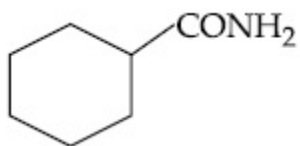

86435115808.

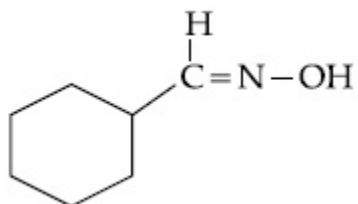

86435115809.

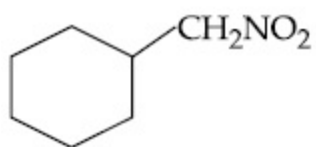

86435115810.

**Question Number : 46 Question Id : 8643515266 Question Type : MCQ Option Shuffling : Yes Is**

**Question Mandatory : No**

**Correct Marks : 4 Wrong Marks : 1**

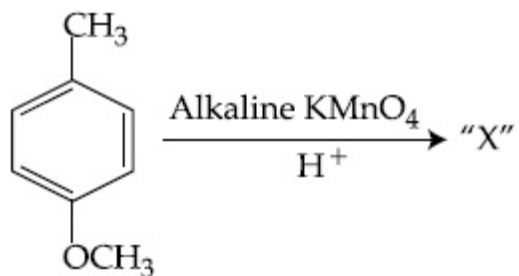

Considering the above chemical reaction, identify the product "X" :

Options :

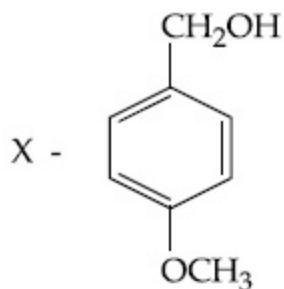

86435115811.

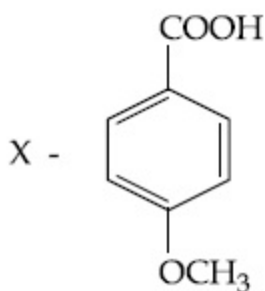

86435115812.

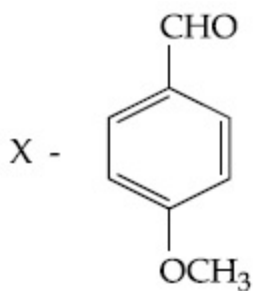

86435115813.

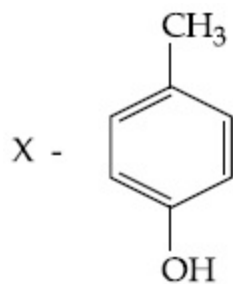

86435115814.

**Question Mandatory : No**

**Correct Marks : 4 Wrong Marks : 1**

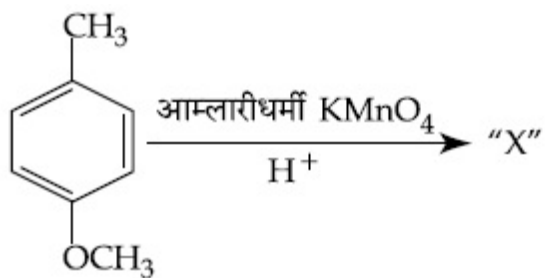

वरील अभिक्रिया लक्षात घ्या, उत्पाद "X" ओळखा.

**Options :**

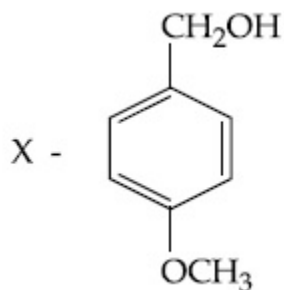

86435115811.

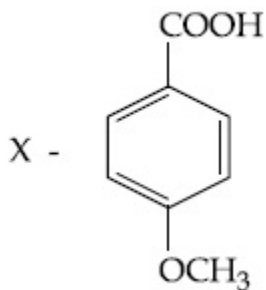

86435115812.

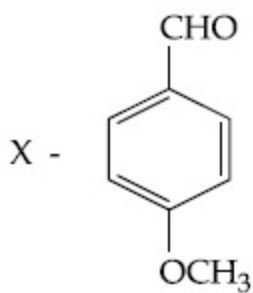

86435115813.

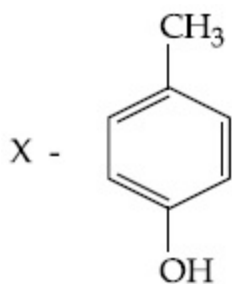

86435115814.

Question Number : 47 Question Id : 8643515267 Question Type : MCQ Option Shuffling : Yes Is Question Mandatory : No Correct Marks : 4 Wrong Marks : 1

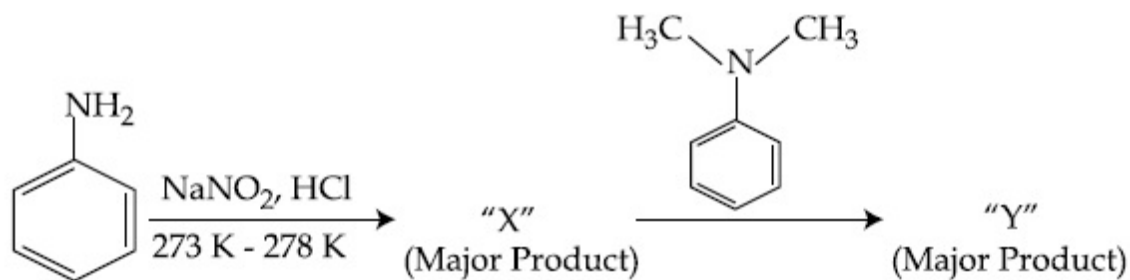

Considering the above reaction, X and Y respectively are :

Options :

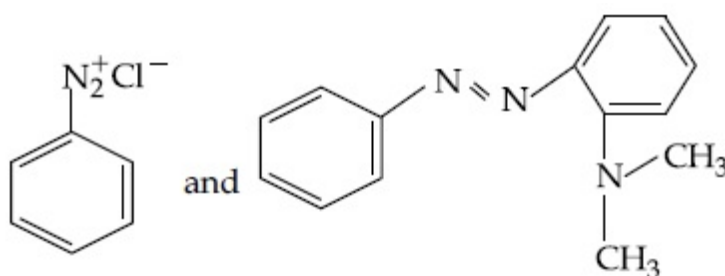

86435115815.

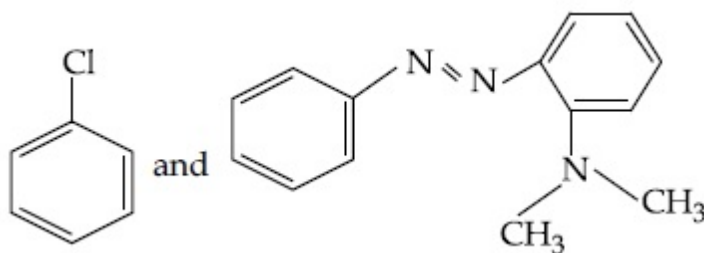

86435115816.

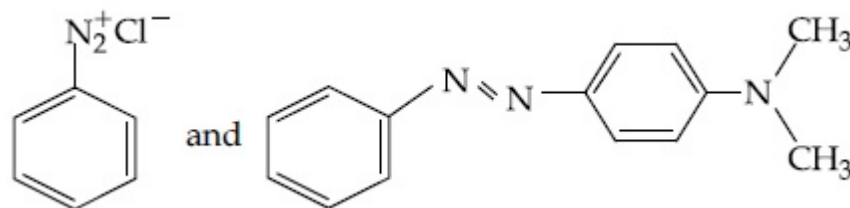

86435115817.

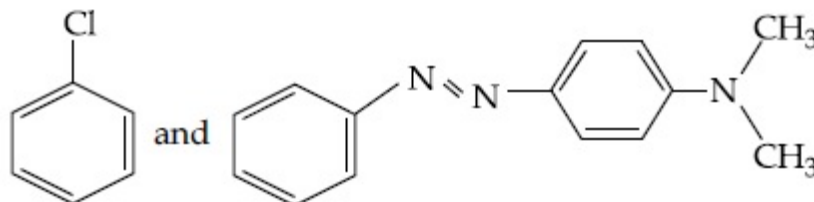

86435115818.

Question Number : 47 Question Id : 8643515267 Question Type : MCQ Option Shuffling : Yes Is Question Mandatory : No

Correct Marks : 4 Wrong Marks : 1

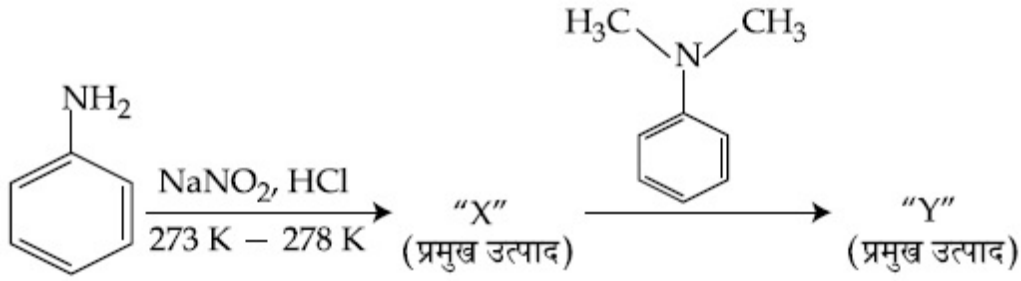

वरील अभिक्रिया लक्षात घ्या तर X आणि Y अनुक्रमे \_\_\_\_\_ आहेत.

Options :

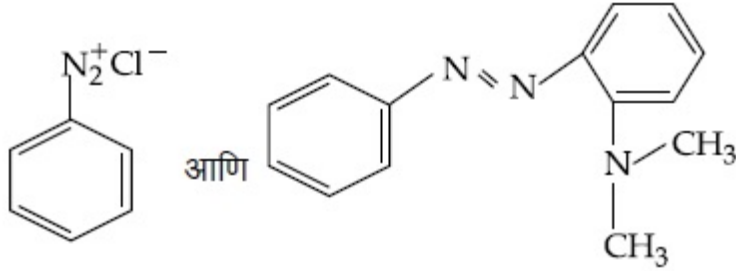

86435115815.

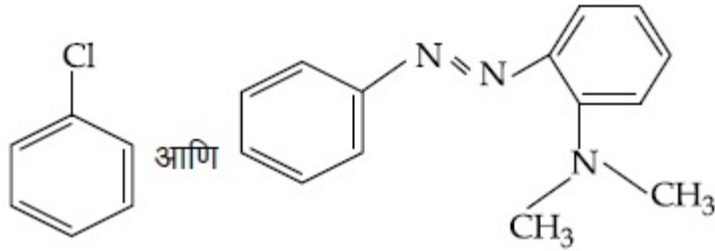

86435115816.

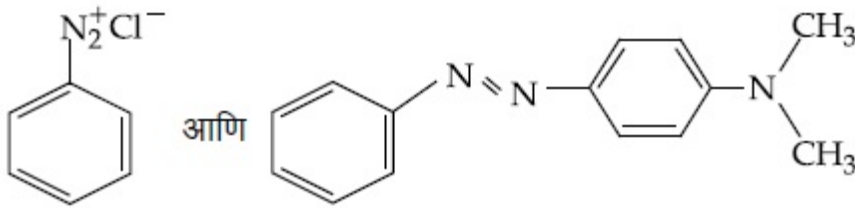

86435115817.

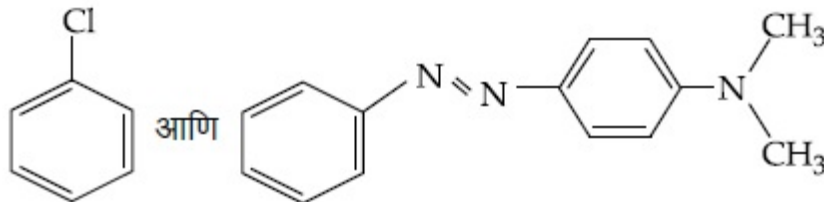

86435115818.

Question Number : 48 Question Id : 8643515268 Question Type : MCQ Option Shuffling : Yes Is Question Mandatory : No

Correct Marks : 4 Wrong Marks : 1

Match List - I with List - II :

List - I (Class of Drug)	List - II (Example)
(a) Antacid	(i) Novestrol
(b) Artificial Sweetener	(ii) Cimetidine
(c) Antifertility	(iii) Valium
(d) Tranquilizers	(iv) Alitame

Choose the most appropriate match :

Options :

86435115819. (a)-(ii), (b)-(iv), (c)-(iii), (d)-(i)

86435115820. (a)-(ii), (b)-(iv), (c)-(i), (d)-(iii)

86435115821. (a)-(iv), (b)-(i), (c)-(ii), (d)-(iii)

86435115822. (a)-(iv), (b)-(iii), (c)-(i), (d)-(ii)

Question Number : 48 Question Id : 8643515268 Question Type : MCQ Option Shuffling : Yes Is Question Mandatory : No

Correct Marks : 4 Wrong Marks : 1

यादी - I यादी - II बरोबर जुळवा.

यादी - I (औषधाचा वर्ग)	यादी - II (उदाहरण)
(a) प्रतिआम्ल	(i) नोव्होस्टेरॉल
(b) कृत्रिम माधुर्यकारक	(ii) सिमेटिडीन
(c) प्रतिफलनक्षमता	(iii) व्हेलिअम
(d) प्रशांतक	(iv) अलटेम

योग्य जोडी निवडा :

Options :

86435115819. (a)-(ii), (b)-(iv), (c)-(iii), (d)-(i)

86435115820. (a)-(ii), (b)-(iv), (c)-(i), (d)-(iii)

86435115821. (a)-(iv), (b)-(i), (c)-(ii), (d)-(iii)

86435115822. (a)-(iv), (b)-(iii), (c)-(i), (d)-(ii)

**Question Number : 49 Question Id : 8643515269 Question Type : MCQ Option Shuffling : Yes Is Question Mandatory : No**

**Correct Marks : 4 Wrong Marks : 1**

A non-reducing sugar "A" hydrolyses to give two reducing mono saccharides. Sugar A is :

**Options :**

86435115823. Glucose

86435115824. Fructose

86435115825. Galactose

86435115826. Sucrose

**Question Number : 49 Question Id : 8643515269 Question Type : MCQ Option Shuffling : Yes Is Question Mandatory : No**

**Correct Marks : 4 Wrong Marks : 1**

दोन क्षपणकारक मोनोसॅकराइड ज्या एका अक्षपणकारी शर्करेच्या जलीय अपघटनातून मिळतात अशी शर्करा A \_\_\_\_\_ आहे.

**Options :**

86435115823. ग्लुकोज

86435115824. फ्रुक्टोज

86435115825. गॅलाक्टोज

86435115826. सुक्रोज

**Question Number : 50 Question Id : 8643515270 Question Type : MCQ Option Shuffling : Yes Is Question Mandatory : No**

**Correct Marks : 4 Wrong Marks : 1**

Reagent, 1-naphthylamine and sulphanilic acid in acetic acid is used for the detection of :

**Options :**

86435115827.  $\text{NO}_2^-$

86435115828.  $\text{NO}_3^-$

86435115829.  $\text{NO}$

86435115830.  $\text{N}_2\text{O}$

**Question Number : 50 Question Id : 8643515270 Question Type : MCQ Option Shuffling : Yes Is**

**Question Mandatory : No**

**Correct Marks : 4 Wrong Marks : 1**

1-नॅफ्थिलअमाइन आणि अॅसेटिक आम्लातील सल्फॅनिलिक आम्ल ह्या अभिक्रियाकारकाचा उपयोग \_\_\_\_\_ शोधण्यासाठी होतो.

**Options :**

86435115827.  $\text{NO}_2^-$

86435115828.  $\text{NO}_3^-$

86435115829.  $\text{NO}$

86435115830.  $\text{N}_2\text{O}$

## Chemistry Section B

<b>Section Id :</b>	864351352
<b>Section Number :</b>	4
<b>Section type :</b>	Online
<b>Mandatory or Optional :</b>	Mandatory
<b>Number of Questions :</b>	10
<b>Number of Questions to be attempted :</b>	5
<b>Section Marks :</b>	20
<b>Mark As Answered Required? :</b>	Yes
<b>Sub-Section Number :</b>	1
<b>Sub-Section Id :</b>	864351352



Question Shuffling Allowed :

Yes

Question Number : 51 Question Id : 8643515271 Question Type : SA

Correct Marks : 4 Wrong Marks : 0

Complete combustion of 3 g of ethane gives  $x \times 10^{22}$  molecules of water. The value of  $x$  is \_\_\_\_\_ . (Round off to the Nearest Integer).

[Use :  $N_A = 6.023 \times 10^{23}$ ; Atomic masses in u : C : 12.0 ; O : 16.0 ; H : 1.0]

Response Type : Numeric

Evaluation Required For SA : Yes

Show Word Count : Yes

Answers Type : Equal

Text Areas : PlainText

Possible Answers :

100

Question Number : 51 Question Id : 8643515271 Question Type : SA

Correct Marks : 4 Wrong Marks : 0

3 g इथेनच्या संपूर्ण ज्वलनातून  $x \times 10^{22}$  पाण्याचे रेणु दिले जातात.  $x$  ची किंमत \_\_\_\_\_ आहे.

(जवळच्या पूर्णांकात)

[ वापरा :  $N_A = 6.023 \times 10^{23}$ ; अणु वस्तुमान C : 12.0 u ; O : 16.0 u ; H : 1.0 u ]

Response Type : Numeric

Evaluation Required For SA : Yes

Show Word Count : Yes

Answers Type : Equal

Text Areas : PlainText

Possible Answers :

100

Question Number : 52 Question Id : 8643515272 Question Type : SA

Correct Marks : 4 Wrong Marks : 0

AX is a covalent diatomic molecule where A and X are second row elements of periodic table. Based on Molecular orbital theory, the bond order of AX is 2.5. The total number of electrons in AX is \_\_\_\_\_. (Round off to the Nearest Integer).

Response Type : Numeric

Evaluation Required For SA : Yes

Show Word Count : Yes

Answers Type : Equal

Text Areas : PlainText

Possible Answers :

100

**Question Number : 52 Question Id : 8643515272 Question Type : SA****Correct Marks : 4 Wrong Marks : 0**

A आणि X ह्या आवर्त सारणीच्या दुसऱ्या रांगेतील मूलद्रव्यांचे AX हे सहसंयुज द्विअण्वीय संयुग आहे. रेणु कक्षिका सिद्धांतानुसार AX ची बंध कोटी 2.5 आहे. AX संयुगातील एकूण इलेक्ट्रॉन्सची संख्या \_\_\_\_\_ आहे. (पूर्णाकात उत्तर)

**Response Type : Numeric****Evaluation Required For SA : Yes****Show Word Count : Yes****Answers Type : Equal****Text Areas : PlainText****Possible Answers :**

100

**Question Number : 53 Question Id : 8643515273 Question Type : SA****Correct Marks : 4 Wrong Marks : 0**

For the reaction

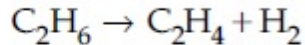

the reaction enthalpy  $\Delta_r H =$  \_\_\_\_\_  $\text{kJ mol}^{-1}$ . (Round off to the Nearest Integer).

[Given : Bond enthalpies in  $\text{kJ mol}^{-1}$  : C-C : 347, C=C : 611;

C-H : 414, H-H : 436]

**Response Type : Numeric****Evaluation Required For SA : Yes****Show Word Count : Yes****Answers Type : Equal****Text Areas : PlainText****Possible Answers :**

100

**Question Number : 53 Question Id : 8643515273 Question Type : SA****Correct Marks : 4 Wrong Marks : 0**

अभिक्रियेसाठी

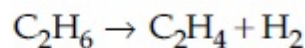

अभिक्रियेची एन्थॅल्पी  $\Delta_r H =$  \_\_\_\_\_  $\text{kJ mol}^{-1}$ . (जवळच्या पूर्णाकात)

[ दिलेले आहे : बंध एन्थॅल्पी : C-C : 347, C=C : 611;

$\text{kJ mol}^{-1}$  मध्ये C-H : 414, H-H : 436]

**Response Type :** Numeric

**Evaluation Required For SA :** Yes

**Show Word Count :** Yes

**Answers Type :** Equal

**Text Areas :** PlainText

**Possible Answers :**

100

**Question Number : 54 Question Id : 8643515274 Question Type : SA**

**Correct Marks : 4 Wrong Marks : 0**

2 molal solution of a weak acid HA has a freezing point of  $3.885^{\circ}\text{C}$ . The degree of dissociation of this acid is \_\_\_\_\_  $\times 10^{-3}$ . (Round off to the Nearest Integer).

[Given : Molal depression constant of water =  $1.85 \text{ K kg mol}^{-1}$

Freezing point of pure water =  $0^{\circ}\text{C}$ ]

**Response Type :** Numeric

**Evaluation Required For SA :** Yes

**Show Word Count :** Yes

**Answers Type :** Equal

**Text Areas :** PlainText

**Possible Answers :**

100

**Question Number : 54 Question Id : 8643515274 Question Type : SA**

**Correct Marks : 4 Wrong Marks : 0**

HA ह्या सौम्य आम्लाच्या 2 मोलल द्रावणाचा गोठणांक  $3.885^{\circ}\text{C}$  आहे. ह्या आम्लाचा विचरणांश \_\_\_\_\_  $\times 10^{-3}$  आहे. (जवळच्या पूर्णांकात)

[ दिलेले आहे : पाण्यासाठी मोलल घट स्थिरांक =  $1.85 \text{ K kg mol}^{-1}$

शुद्ध पाण्याचा गोठणांक =  $0^{\circ}\text{C}$ ]

**Response Type :** Numeric

**Evaluation Required For SA :** Yes

**Show Word Count :** Yes

**Answers Type :** Equal

**Text Areas :** PlainText

**Possible Answers :**

100

**Question Number : 55 Question Id : 8643515275 Question Type : SA**

**Correct Marks : 4 Wrong Marks : 0**

In order to prepare a buffer solution of pH 5.74, sodium acetate is added to acetic acid. If the concentration of acetic acid in the buffer is 1.0 M, the concentration of sodium acetate in the buffer is \_\_\_\_\_ M. (Round off to the Nearest Integer).

[Given : pKa (acetic acid) = 4.74]

**Response Type :** Numeric

**Evaluation Required For SA :** Yes

**Show Word Count :** Yes

**Answers Type :** Equal

**Text Areas :** PlainText

**Possible Answers :**

100

**Question Number :** 55 **Question Id :** 8643515275 **Question Type :** SA

**Correct Marks :** 4 **Wrong Marks :** 0

5.74 pH चे उभयरोधी द्रावण बनवण्यासाठी सोडीअम ॲसिटेट ॲसेटिक आम्लात घालतात. जर ॲसेटिक आम्लाची उभयरोधी द्रावणातील संहती 1.0 M असेल तर सोडीअम ॲसिटेटची उभयरोधी द्रावणातील संहती \_\_\_\_\_ M आहे. (जवळच्या पूर्णांकात)

[ दिलेले आहे : pKa (ॲसेटिक अम्ल) = 4.74 ]

**Response Type :** Numeric

**Evaluation Required For SA :** Yes

**Show Word Count :** Yes

**Answers Type :** Equal

**Text Areas :** PlainText

**Possible Answers :**

100

**Question Number :** 56 **Question Id :** 8643515276 **Question Type :** SA

**Correct Marks :** 4 **Wrong Marks :** 0

For the reaction

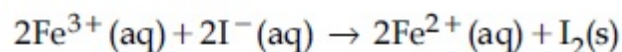

the magnitude of the standard molar free energy change,

$\Delta_r G_m^\circ = -$  \_\_\_\_\_ kJ (Round off to the Nearest Integer).

$$\left[ \begin{array}{l} E^\circ_{\text{Fe}^{2+}/\text{Fe}(\text{s})} = -0.440 \text{ V}; E^\circ_{\text{Fe}^{3+}/\text{Fe}(\text{s})} = -0.036 \text{ V} \\ E^\circ_{\text{I}_2/2\text{I}^{-}} = 0.539 \text{ V}; \quad F = 96500 \text{ C} \end{array} \right]$$

**Response Type :** Numeric

**Evaluation Required For SA : Yes**

**Show Word Count : Yes**

**Answers Type : Equal**

**Text Areas : PlainText**

**Possible Answers :**

100

**Question Number : 56 Question Id : 8643515276 Question Type : SA**

**Correct Marks : 4 Wrong Marks : 0**

अभिक्रियेसाठी

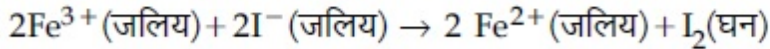

मानक ग्रमरेण्वीय मुक्त ऊर्जेच्या बदलाची किंमत  $\Delta_r G_m^\circ = - \text{_____ kJ}$  आहे.

(जवळच्या पूर्णांकात)

$$\left[ \begin{array}{l} E^\circ_{\text{Fe}^{2+}/\text{Fe(s)}} = -0.440 \text{ V}; E^\circ_{\text{Fe}^{3+}/\text{Fe(s)}} = -0.036 \text{ V} \\ E^\circ_{\text{I}_2/2\text{I}^{-}} = 0.539 \text{ V}; \quad F = 96500 \text{ C} \end{array} \right]$$

**Response Type : Numeric**

**Evaluation Required For SA : Yes**

**Show Word Count : Yes**

**Answers Type : Equal**

**Text Areas : PlainText**

**Possible Answers :**

100

**Question Number : 57 Question Id : 8643515277 Question Type : SA**

**Correct Marks : 4 Wrong Marks : 0**

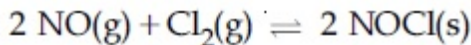

This reaction was studied at  $-10^\circ\text{C}$  and the following data was obtained

run	$[\text{NO}]_0$	$[\text{Cl}_2]_0$	$r_0$
1	0.10	0.10	0.18
2	0.10	0.20	0.35
3	0.20	0.20	1.40

$[\text{NO}]_0$  and  $[\text{Cl}_2]_0$  are the initial concentrations and  $r_0$  is the initial reaction rate.

The overall order of the reaction is \_\_\_\_\_. (Round off to the Nearest Integer).

**Response Type : Numeric**

**Evaluation Required For SA : Yes**

Show Word Count : Yes

Answers Type : Equal

Text Areas : PlainText

Possible Answers :

100

Question Number : 57 Question Id : 8643515277 Question Type : SA

Correct Marks : 4 Wrong Marks : 0

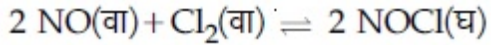

अभिक्रिया  $-10^\circ\text{C}$  ला अभ्यासली असता खालील माहिती मिळाली.

क्रम (run)	$[\text{NO}]_0$	$[\text{Cl}_2]_0$	$r_0$
1	0.10	0.10	0.18
2	0.10	0.20	0.35
3	0.20	0.20	1.40

$[\text{NO}]_0$  आणि  $[\text{Cl}_2]_0$  ह्या सुरवातीच्या संहती आहेत तर  $r_0$  हा सुरवातीचा अभिक्रियेचा वेग आहे. तर अभिक्रियेची समग्र कोटी \_\_\_\_\_ आहे. (जवळच्या पूर्णाकात)

Response Type : Numeric

Evaluation Required For SA : Yes

Show Word Count : Yes

Answers Type : Equal

Text Areas : PlainText

Possible Answers :

100

Question Number : 58 Question Id : 8643515278 Question Type : SA

Correct Marks : 4 Wrong Marks : 0

The total number of unpaired electrons present in the complex  $\text{K}_3[\text{Cr}(\text{oxalate})_3]$  is \_\_\_\_\_.

Response Type : Numeric

Evaluation Required For SA : Yes

Show Word Count : Yes

Answers Type : Equal

Text Areas : PlainText

Possible Answers :

100

Question Number : 58 Question Id : 8643515278 Question Type : SA

Correct Marks : 4 Wrong Marks : 0

$K_3[Cr(\text{ऑक्झालेट})_3]$  ह्या संकुलातील एकुण अयुग्मी इलेक्ट्रॉन्सची संख्या \_\_\_\_\_ आहे.

**Response Type :** Numeric

**Evaluation Required For SA :** Yes

**Show Word Count :** Yes

**Answers Type :** Equal

**Text Areas :** PlainText

**Possible Answers :**

100

**Question Number : 59 Question Id : 8643515279 Question Type : SA**

**Correct Marks : 4 Wrong Marks : 0**

\_\_\_\_\_ grams of 3-Hydroxy propanal (MW = 74) must be dehydrated to produce 7.8 g of acrolein (MW = 56) ( $C_3H_4O$ ) if the percentage yield is 64. (Round off to the Nearest Integer).

[Given : Atomic masses : C : 12.0 u, H : 1.0 u, O : 16.0 u]

**Response Type :** Numeric

**Evaluation Required For SA :** Yes

**Show Word Count :** Yes

**Answers Type :** Equal

**Text Areas :** PlainText

**Possible Answers :**

100

**Question Number : 59 Question Id : 8643515279 Question Type : SA**

**Correct Marks : 4 Wrong Marks : 0**

7.8 g अॅकोलिन (MW = 56) ( $C_3H_4O$ ) ची 64 टक्के प्राप्ती असण्यासाठी \_\_\_\_\_ ग्रॅम 3-हायड्रॉक्सी प्रोपॅनल (MW = 74) चे निर्जलीकरण करणे आवश्यक आहे. (जवळच्या पूर्णांकात)

[ दिलेले आहे : अणु वस्तुमान : C : 12.0 u, H : 1.0 u, O : 16.0 u ]

**Response Type :** Numeric

**Evaluation Required For SA :** Yes

**Show Word Count :** Yes

**Answers Type :** Equal

**Text Areas :** PlainText

**Possible Answers :**

100

**Question Number : 60 Question Id : 8643515280 Question Type : SA**

**Correct Marks : 4 Wrong Marks : 0**

A reaction of 0.1 mole of Benzylamine with bromomethane gave 23 g of Benzyl trimethyl ammonium bromide. The number of moles of bromomethane consumed in this reaction are  $n \times 10^{-1}$ , when  $n = \underline{\hspace{2cm}}$ . (Round off to the Nearest Integer).

[Given : Atomic masses : C : 12.0 u, H : 1.0 u, N : 14.0 u, Br : 80.0 u]

**Response Type :** Numeric

**Evaluation Required For SA :** Yes

**Show Word Count :** Yes

**Answers Type :** Equal

**Text Areas :** PlainText

**Possible Answers :**

100

**Question Number :** 60 **Question Id :** 8643515280 **Question Type :** SA

**Correct Marks :** 4 **Wrong Marks :** 0

0.1 मोल बेंझिलअमाइनच्या ब्रोमोमिथेनशी अभिक्रियेत 23 g बेंझिल ट्रायमिथाइल अमोनियम ब्रोमाइड मिळाले. ब्रोमोमिथेनचे अभिक्रियेत वापरण्यात आलेल्या मोल्सची संख्या  $n \times 10^{-1}$  आहे तर  $n = \underline{\hspace{2cm}}$ . (जवळच्या पूर्णांकात)

[ दिलेले आहे : अणु वस्तुमान : C : 12.0 u, H : 1.0 u, N : 14.0 u, Br : 80.0 u ]

**Response Type :** Numeric

**Evaluation Required For SA :** Yes

**Show Word Count :** Yes

**Answers Type :** Equal

**Text Areas :** PlainText

**Possible Answers :**

100

## Mathematics Section A

<b>Section Id :</b>	864351353
<b>Section Number :</b>	5
<b>Section type :</b>	Online
<b>Mandatory or Optional :</b>	Mandatory
<b>Number of Questions :</b>	20
<b>Number of Questions to be attempted :</b>	20
<b>Section Marks :</b>	80
<b>Mark As Answered Required? :</b>	Yes
<b>Sub-Section Number :</b>	1
<b>Sub-Section Id :</b>	864351353
<b>Question Shuffling Allowed :</b>	Yes



**Question Number : 61 Question Id : 8643515281 Question Type : MCQ Option Shuffling : Yes Is**

**Question Mandatory : No**

**Correct Marks : 4 Wrong Marks : 1**

If the functions are defined as  $f(x) = \sqrt{x}$  and  $g(x) = \sqrt{1-x}$ , then what is the common domain of the following functions :  $f+g$ ,  $f-g$ ,  $f/g$ ,  $g/f$ ,  $g-f$  where

$$(f \pm g)(x) = f(x) \pm g(x), (f/g)(x) = \frac{f(x)}{g(x)}$$

**Options :**

86435115841.  $0 \leq x < 1$

86435115842.  $0 < x < 1$

86435115843.  $0 \leq x \leq 1$

86435115844.  $0 < x \leq 1$

**Question Number : 61 Question Id : 8643515281 Question Type : MCQ Option Shuffling : Yes Is**

**Question Mandatory : No**

**Correct Marks : 4 Wrong Marks : 1**

जर फल  $f(x) = \sqrt{x}$  आणि  $g(x) = \sqrt{1-x}$  हे निश्चित आहेत, तर  $f+g$ ,  $f-g$ ,  $f/g$ ,  $g/f$ ,  $g-f$  जेव्हा

$$(f \pm g)(x) = f(x) \pm g(x), (f/g)(x) = \frac{f(x)}{g(x)},$$

या फलांचे सामाईक अधिकक्षेत्र (Common domain) कोणते

आहे?

**Options :**

86435115841.  $0 \leq x < 1$

86435115842.  $0 < x < 1$

86435115843.  $0 \leq x \leq 1$

86435115844.  $0 < x \leq 1$

**Question Number : 62 Question Id : 8643515282 Question Type : MCQ Option Shuffling : Yes Is**

**Question Mandatory : No**

**Correct Marks : 4 Wrong Marks : 1**

If the equation  $a|z|^2 + \overline{\alpha}z + \alpha\overline{z} + d = 0$  represents a circle where  $a, d$  are real constants, then which of the following condition is correct ?

**Options :**

86435115845.  $|\alpha|^2 - ad \geq 0$  and  $a \in \mathbb{R}$

86435115846.  $|\alpha|^2 - ad > 0$  and  $a \in \mathbb{R} - \{0\}$

86435115847.  $|\alpha|^2 - ad \neq 0$

86435115848.  $\alpha = 0, a, d \in \mathbb{R}^+$

**Question Number : 62 Question Id : 8643515282 Question Type : MCQ Option Shuffling : Yes Is**

**Question Mandatory : No**

**Correct Marks : 4 Wrong Marks : 1**

जर  $a|z|^2 + \overline{\alpha}z + \alpha\overline{z} + d = 0$  हे वर्तुळाचे समीकरण दर्शविते जेव्हा  $a, d$  हे वास्तव अचल आहेत, तर खालीलपैकी कोणती शर्त (condition) बरोबर आहे ?

**Options :**

86435115845.  $|\alpha|^2 - ad \geq 0$  आणि  $a \in \mathbb{R}$

86435115846.  $|\alpha|^2 - ad > 0$  आणि  $a \in \mathbb{R} - \{0\}$

86435115847.  $|\alpha|^2 - ad \neq 0$

86435115848.  $\alpha = 0, a, d \in \mathbb{R}^+$

**Question Number : 63 Question Id : 8643515283 Question Type : MCQ Option Shuffling : Yes Is**

**Question Mandatory : No**

**Correct Marks : 4 Wrong Marks : 1**

Let  $A + 2B = \begin{bmatrix} 1 & 2 & 0 \\ 6 & -3 & 3 \\ -5 & 3 & 1 \end{bmatrix}$  and  $2A - B = \begin{bmatrix} 2 & -1 & 5 \\ 2 & -1 & 6 \\ 0 & 1 & 2 \end{bmatrix}$ . If  $\text{Tr}(A)$  denotes the sum of all

diagonal elements of the matrix  $A$ , then  $\text{Tr}(A) - \text{Tr}(B)$  has value equal to :

**Options :**

86435115849. 1

86435115850. 2

86435115851. 3

86435115852. 0

**Question Number : 63 Question Id : 8643515283 Question Type : MCQ Option Shuffling : Yes Is Question Mandatory : No**

**Correct Marks : 4 Wrong Marks : 1**

समजा  $A + 2B = \begin{bmatrix} 1 & 2 & 0 \\ 6 & -3 & 3 \\ -5 & 3 & 1 \end{bmatrix}$  आणि  $2A - B = \begin{bmatrix} 2 & -1 & 5 \\ 2 & -1 & 6 \\ 0 & 1 & 2 \end{bmatrix}$ . जर  $\text{Tr}(A)$  ही A सारणीच्या सर्व

कर्णात्मक (diagonal) घटकांची बेरीज दर्शविते, तर  $\text{Tr}(A) - \text{Tr}(B)$  चे मूल्य \_\_\_\_\_ आहे.

**Options :**

86435115849. 1

86435115850. 2

86435115851. 3

86435115852. 0

**Question Number : 64 Question Id : 8643515284 Question Type : MCQ Option Shuffling : Yes Is Question Mandatory : No**

**Correct Marks : 4 Wrong Marks : 1**

Let  $\alpha, \beta, \gamma$  be the real roots of the equation,  $x^3 + ax^2 + bx + c = 0$ , ( $a, b, c \in \mathbb{R}$  and  $a, b \neq 0$ ). If the system of equations (in  $u, v, w$ ) given by  $\alpha u + \beta v + \gamma w = 0$ ;  $\beta u + \gamma v + \alpha w = 0$ ;

$\gamma u + \alpha v + \beta w = 0$  has non-trivial solution, then the value of  $\frac{a^2}{b}$  is :

**Options :**

86435115853. 0

86435115854. 1

86435115855. 3

86435115856. 5

**Question Number : 64 Question Id : 8643515284 Question Type : MCQ Option Shuffling : Yes Is Question Mandatory : No**

**Correct Marks : 4 Wrong Marks : 1**

समजा  $x^3 + ax^2 + bx + c = 0$ , ( $a, b, c \in \mathbb{R}$  आणि  $a, b \neq 0$ ) या समीकरणाची  $\alpha, \beta, \gamma$  ही वास्तव मूळे आहेत.

जर  $\alpha u + \beta v + \gamma w = 0$ ;  $\beta u + \gamma v + \alpha w = 0$ ;  $\gamma u + \alpha v + \beta w = 0$  ही समीकरणांची प्रणाली  $u, v, w$  मध्ये दिलेली

आहे. या समीकरणांची प्रणाली ही शुल्लक उकल नसलेली प्रणाली आहे, तर  $\frac{a^2}{b}$  चे मूल्य \_\_\_\_\_ आहे.

**Options :**

86435115853. 0

86435115854. 1

86435115855. 3

86435115856. 5

**Question Number : 65 Question Id : 8643515285 Question Type : MCQ Option Shuffling : Yes Is Question Mandatory : No**

**Correct Marks : 4 Wrong Marks : 1**

The sum of all the 4-digit distinct numbers that can be formed with the digits 1, 2, 2 and 3 is :

**Options :**

86435115857. 22264

86435115858. 26664

86435115859. 122234

86435115860. 122664

**Question Number : 65 Question Id : 8643515285 Question Type : MCQ Option Shuffling : Yes Is Question Mandatory : No**

**Correct Marks : 4 Wrong Marks : 1**

1, 2, 2 आणि 3 हे अंक वापरून तयार होणाऱ्या 4-अंकी भिन्न संख्यांची बेरीज \_\_\_\_\_ आहे.

**Options :**

86435115857. 22264

86435115858. 26664

86435115859. 122234

86435115860. 122664

**Question Number : 66 Question Id : 8643515286 Question Type : MCQ Option Shuffling : Yes Is Question Mandatory : No**

**Correct Marks : 4 Wrong Marks : 1**

Let  $(1 + x + 2x^2)^{20} = a_0 + a_1x + a_2x^2 + \dots + a_{40}x^{40}$ . Then,  $a_1 + a_3 + a_5 + \dots + a_{37}$  is equal to :

**Options :**

86435115861.  $2^{19}(2^{20} + 21)$

86435115862.  $2^{20}(2^{20} + 21)$

86435115863.  $2^{19}(2^{20} - 21)$

86435115864.  $2^{20}(2^{20} - 21)$

**Question Number : 66 Question Id : 8643515286 Question Type : MCQ Option Shuffling : Yes Is Question Mandatory : No**

**Correct Marks : 4 Wrong Marks : 1**

समजा  $(1 + x + 2x^2)^{20} = a_0 + a_1x + a_2x^2 + \dots + a_{40}x^{40}$ , तर  $a_1 + a_3 + a_5 + \dots + a_{37}$  बरोबर \_\_\_\_\_ आहे.

**Options :**

86435115861.  $2^{19}(2^{20} + 21)$

86435115862.  $2^{20}(2^{20} + 21)$

86435115863.  $2^{19}(2^{20} - 21)$

$$86435115864. \quad 2^{20}(2^{20} - 21)$$

**Question Number : 67 Question Id : 8643515287 Question Type : MCQ Option Shuffling : Yes Is Question Mandatory : No**

**Correct Marks : 4 Wrong Marks : 1**

The value of  $3 + \frac{1}{4 + \frac{1}{3 + \frac{1}{4 + \frac{1}{3 + \dots \infty}}}}$  is equal to :

**Options :**

$$86435115865. \quad 1.5 + \sqrt{3}$$

$$86435115866. \quad 2 + \sqrt{3}$$

$$86435115867. \quad 3 + 2\sqrt{3}$$

$$86435115868. \quad 4 + \sqrt{3}$$

**Question Number : 67 Question Id : 8643515287 Question Type : MCQ Option Shuffling : Yes Is Question Mandatory : No**

**Correct Marks : 4 Wrong Marks : 1**

$3 + \frac{1}{4 + \frac{1}{3 + \frac{1}{4 + \frac{1}{3 + \dots \infty}}}}$  चे मूल्य बरोबर \_\_\_\_\_ आहे.

**Options :**

$$86435115865. \quad 1.5 + \sqrt{3}$$

$$86435115866. \quad 2 + \sqrt{3}$$

$$86435115867. \quad 3 + 2\sqrt{3}$$

$$86435115868. \quad 4 + \sqrt{3}$$

**Question Number : 68 Question Id : 8643515288 Question Type : MCQ Option Shuffling : Yes Is Question Mandatory : No**

**Correct Marks : 4 Wrong Marks : 1**

$$\frac{1}{3^2 - 1} + \frac{1}{5^2 - 1} + \frac{1}{7^2 - 1} + \dots + \frac{1}{(201)^2 - 1} \text{ is equal to :}$$

**Options :**

86435115869.  $\frac{25}{101}$

86435115870.  $\frac{101}{408}$

86435115871.  $\frac{99}{400}$

86435115872.  $\frac{101}{404}$

**Question Number : 68 Question Id : 8643515288 Question Type : MCQ Option Shuffling : Yes Is Question Mandatory : No**

**Correct Marks : 4 Wrong Marks : 1**

$$\frac{1}{3^2 - 1} + \frac{1}{5^2 - 1} + \frac{1}{7^2 - 1} + \dots + \frac{1}{(201)^2 - 1} \text{ बरोबर } \underline{\hspace{2cm}} \text{ आहे.}$$

**Options :**

86435115869.  $\frac{25}{101}$

86435115870.  $\frac{101}{408}$

86435115871.  $\frac{99}{400}$

86435115872.  $\frac{101}{404}$

**Question Number : 69 Question Id : 8643515289 Question Type : MCQ Option Shuffling : Yes Is**

**Question Mandatory : No**

**Correct Marks : 4 Wrong Marks : 1**

If  $\alpha, \beta$  are natural numbers such that  $100^\alpha - 199\beta = (100)(100) + (99)(101) + (98)(102) + \dots + (1)(199)$ , then the slope of the line passing through  $(\alpha, \beta)$  and origin is :

**Options :**

86435115873. 510

86435115874. 530

86435115875. 540

86435115876. 550

**Question Number : 69 Question Id : 8643515289 Question Type : MCQ Option Shuffling : Yes Is**

**Question Mandatory : No**

**Correct Marks : 4 Wrong Marks : 1**

जर  $\alpha, \beta$  या नैसर्गिक संख्या आहेत जसे की  $100^\alpha - 199\beta = (100)(100) + (99)(101) + (98)(102) + \dots + (1)(199)$ , तर  $(\alpha, \beta)$  आणि आरंभ बिंदूमधून जाणाऱ्या रेषेच्या चढ \_\_\_\_\_ आहे.

**Options :**

86435115873. 510

86435115874. 530

86435115875. 540

86435115876. 550

**Question Number : 70 Question Id : 8643515290 Question Type : MCQ Option Shuffling : Yes Is**

**Question Mandatory : No**

**Correct Marks : 4 Wrong Marks : 1**

If  $f(x) = \begin{cases} \frac{1}{|x|} & ; |x| \geq 1 \\ ax^2 + b & ; |x| < 1 \end{cases}$  is differentiable at every point of the domain, then the values of

a and b are respectively :

**Options :**



$$86435115877. \quad \frac{1}{2}, \frac{1}{2}$$

$$86435115878. \quad -\frac{1}{2}, \frac{3}{2}$$

$$86435115879. \quad \frac{5}{2}, -\frac{3}{2}$$

$$86435115880. \quad \frac{1}{2}, -\frac{3}{2}$$

**Question Number : 70 Question Id : 8643515290 Question Type : MCQ Option Shuffling : Yes Is Question Mandatory : No**

**Correct Marks : 4 Wrong Marks : 1**

जर  $f(x) = \begin{cases} \frac{1}{|x|} & ; |x| \geq 1 \\ ax^2 + b & ; |x| < 1 \end{cases}$  हे आपल्या अधिक्षेत्राच्या प्रत्येक बिंदूवर संतत आणि विकलनीय आहे, तर

a आणि b चे मूल्य अनुक्रमे \_\_\_\_\_ आहेत.

**Options :**

$$86435115877. \quad \frac{1}{2}, \frac{1}{2}$$

$$86435115878. \quad -\frac{1}{2}, \frac{3}{2}$$

$$86435115879. \quad \frac{5}{2}, -\frac{3}{2}$$

$$86435115880. \quad \frac{1}{2}, -\frac{3}{2}$$

**Question Number : 71 Question Id : 8643515291 Question Type : MCQ Option Shuffling : Yes Is Question Mandatory : No**

**Correct Marks : 4 Wrong Marks : 1**

The real valued function  $f(x) = \frac{\operatorname{cosec}^{-1}x}{\sqrt{x - [x]}}$ , where  $[x]$  denotes the greatest integer less than or

equal to  $x$ , is defined for all  $x$  belonging to :

**Options :**

86435115881. all reals except integers

86435115882. all reals except the interval  $[-1, 1]$

86435115883. all non-integers except the interval  $[-1, 1]$

86435115884. all integers except  $0, -1, 1$

**Question Number : 71 Question Id : 8643515291 Question Type : MCQ Option Shuffling : Yes Is**

**Question Mandatory : No**

**Correct Marks : 4 Wrong Marks : 1**

वास्तव मूल्य फल  $f(x) = \frac{\operatorname{cosec}^{-1}x}{\sqrt{x - [x]}}$ ; जेव्हा  $[x]$  हे महत्तम पूर्णांक  $\leq x$  आहे, सर्व  $x$  साठी निश्चित आहे :

**Options :**

86435115881. पूर्णांकाच्या व्यतिरिक्त सर्व वास्तव संख्या

86435115882.  $[-1, 1]$  या अंतरालाव्यतिरिक्त सर्व वास्तव संख्या

86435115883.  $[-1, 1]$  या अंतरालाव्यतिरिक्त सर्व अपूर्णांक संख्या

86435115884.  $0, -1, 1$  व्यतिरिक्त सर्व पूर्णांक संख्या

**Question Number : 72 Question Id : 8643515292 Question Type : MCQ Option Shuffling : Yes Is**

**Question Mandatory : No**

**Correct Marks : 4 Wrong Marks : 1**

If  $\lim_{x \rightarrow 0} \frac{\sin^{-1}x - \tan^{-1}x}{3x^3}$  is equal to  $L$ , then the value of  $(6L + 1)$  is :

**Options :**

86435115885.  $\frac{1}{6}$

86435115886. 6

86435115887. 2

86435115888.  $\frac{1}{2}$ 

**Question Number : 72 Question Id : 8643515292 Question Type : MCQ Option Shuffling : Yes Is Question Mandatory : No**

**Correct Marks : 4 Wrong Marks : 1**

जर  $\lim_{x \rightarrow 0} \frac{\sin^{-1} x - \tan^{-1} x}{3x^3} = L$  आहे, तर  $(6L + 1)$  चे मूल्य \_\_\_\_\_ आहे.

**Options :**

86435115885.  $\frac{1}{6}$ 

86435115886. 6

86435115887. 2

86435115888.  $\frac{1}{2}$ 

**Question Number : 73 Question Id : 8643515293 Question Type : MCQ Option Shuffling : Yes Is Question Mandatory : No**

**Correct Marks : 4 Wrong Marks : 1**

The integral  $\int \frac{(2x - 1) \cos \sqrt{(2x - 1)^2 + 5}}{\sqrt{4x^2 - 4x + 6}} dx$  is equal to :

(where c is a constant of integration)

**Options :**

86435115889.  $\frac{1}{2} \sin \sqrt{(2x + 1)^2 + 5} + c$ 86435115890.  $\frac{1}{2} \sin \sqrt{(2x - 1)^2 + 5} + c$

86435115891.  $\frac{1}{2} \cos \sqrt{(2x-1)^2 + 5} + c$

86435115892.  $\frac{1}{2} \cos \sqrt{(2x+1)^2 + 5} + c$

**Question Number : 73 Question Id : 8643515293 Question Type : MCQ Option Shuffling : Yes Is Question Mandatory : No**

**Correct Marks : 4 Wrong Marks : 1**

पूर्णांकी  $\int \frac{(2x-1) \cos \sqrt{(2x-1)^2 + 5}}{\sqrt{4x^2 - 4x + 6}} dx$  बरोबर \_\_\_\_\_ आहे.

(जेव्हा c हा संकलनाचा अचल आहे)

**Options :**

86435115889.  $\frac{1}{2} \sin \sqrt{(2x+1)^2 + 5} + c$

86435115890.  $\frac{1}{2} \sin \sqrt{(2x-1)^2 + 5} + c$

86435115891.  $\frac{1}{2} \cos \sqrt{(2x-1)^2 + 5} + c$

86435115892.  $\frac{1}{2} \cos \sqrt{(2x+1)^2 + 5} + c$

**Question Number : 74 Question Id : 8643515294 Question Type : MCQ Option Shuffling : Yes Is Question Mandatory : No**

**Correct Marks : 4 Wrong Marks : 1**

The differential equation satisfied by the system of parabolas  $y^2 = 4a(x+a)$  is :

**Options :**

86435115893.  $y \left( \frac{dy}{dx} \right)^2 + 2x \left( \frac{dy}{dx} \right) - y = 0$

86435115894.  $y \left( \frac{dy}{dx} \right) + 2x \left( \frac{dy}{dx} \right) - y = 0$

86435115895.  $y\left(\frac{dy}{dx}\right)^2 - 2x\left(\frac{dy}{dx}\right) + y = 0$

86435115896.  $y\left(\frac{dy}{dx}\right)^2 - 2x\left(\frac{dy}{dx}\right) - y = 0$

**Question Number : 74 Question Id : 8643515294 Question Type : MCQ Option Shuffling : Yes Is Question Mandatory : No**

**Correct Marks : 4 Wrong Marks : 1**

खालीलपैकी कोणते विकलक समीकरण  $y^2 = 4a(x + a)$  या अन्वस्ताच्या प्रणाली द्वारे समाधान करतो?

**Options :**

86435115893.  $y\left(\frac{dy}{dx}\right)^2 + 2x\left(\frac{dy}{dx}\right) - y = 0$

86435115894.  $y\left(\frac{dy}{dx}\right) + 2x\left(\frac{dy}{dx}\right) - y = 0$

86435115895.  $y\left(\frac{dy}{dx}\right)^2 - 2x\left(\frac{dy}{dx}\right) + y = 0$

86435115896.  $y\left(\frac{dy}{dx}\right)^2 - 2x\left(\frac{dy}{dx}\right) - y = 0$

**Question Number : 75 Question Id : 8643515295 Question Type : MCQ Option Shuffling : Yes Is Question Mandatory : No**

**Correct Marks : 4 Wrong Marks : 1**

Choose the correct statement about two circles whose equations are given below :

$$x^2 + y^2 - 10x - 10y + 41 = 0$$

$$x^2 + y^2 - 22x - 10y + 137 = 0$$

**Options :**

86435115897. circles have two meeting points

86435115898. circles have no meeting point

86435115899. circles have only one meeting point

86435115900. circles have same centre

**Question Number : 75 Question Id : 8643515295 Question Type : MCQ Option Shuffling : Yes Is Question Mandatory : No**

**Correct Marks : 4 Wrong Marks : 1**

दोन वर्तुळे ज्यांची समीकरणे

$$x^2 + y^2 - 10x - 10y + 41 = 0$$

$x^2 + y^2 - 22x - 10y + 137 = 0$  आहेत, या वर्तुळांबाबत बरोबर विधान शोधा.

**Options :**

86435115897. वर्तुळ दोन बिंदूवर भेटत आहेत.

86435115898. वर्तुळ कोणत्याही बिंदूवर भेटत नाही.

86435115899. वर्तुळ फक्त एका बिंदूवर भेटतो

86435115900. एक बिंदू दोन्ही वर्तुळांचा केंद्र आहे.

**Question Number : 76 Question Id : 8643515296 Question Type : MCQ Option Shuffling : Yes Is Question Mandatory : No**

**Correct Marks : 4 Wrong Marks : 1**

For the four circles M, N, O and P, following four equations are given :

Circle M :  $x^2 + y^2 = 1$

Circle N :  $x^2 + y^2 - 2x = 0$

Circle O :  $x^2 + y^2 - 2x - 2y + 1 = 0$

Circle P :  $x^2 + y^2 - 2y = 0$

If the centre of circle M is joined with centre of the circle N, further centre of circle N is joined with centre of the circle O, centre of circle O is joined with the centre of circle P and lastly, centre of circle P is joined with centre of circle M, then these lines form the sides of a :

**Options :**

86435115901. Rectangle

86435115902. Rhombus

86435115903. Square

86435115904. Parallelogram

**Question Number : 76 Question Id : 8643515296 Question Type : MCQ Option Shuffling : Yes Is**

**Question Mandatory : No**

**Correct Marks : 4 Wrong Marks : 1**

चार वर्तुळे M, N, O आणि P यांची समीकरणे खाली दिलेली आहेत :

$$\text{वर्तुळ M : } x^2 + y^2 = 1$$

$$\text{वर्तुळ N : } x^2 + y^2 - 2x = 0$$

$$\text{वर्तुळ O : } x^2 + y^2 - 2x - 2y + 1 = 0$$

$$\text{वर्तुळ P : } x^2 + y^2 - 2y = 0$$

जर वर्तुळ M चे केंद्र वर्तुळ N च्या केंद्राशी जुळविले जात आहे, वर्तुळ N चे केंद्र वर्तुळ O च्या केंद्राशी जुळविले जात आहे, वर्तुळ O चे केंद्र वर्तुळ P च्या केंद्राशी जुळविले जाते आणि शेवटी वर्तुळ P चे केंद्र वर्तुळ M च्या केंद्राशी जुळविले जाते, तर या रेषा खालीलपैकी कोणाची बाजू आहे ?

**Options :**

86435115901. आयत

86435115902. समभुज चौकोन

86435115903. चौरस

86435115904. समांतरभुज चौकोन

**Question Number : 77 Question Id : 8643515297 Question Type : MCQ Option Shuffling : Yes Is**

**Question Mandatory : No**

**Correct Marks : 4 Wrong Marks : 1**

The number of integral values of m so that the abscissa of point of intersection of lines  $3x + 4y = 9$  and  $y = mx + 1$  is also an integer, is :

**Options :**

86435115905. 0

86435115906. 1

86435115907. 2

86435115908. 3

**Question Number : 77 Question Id : 8643515297 Question Type : MCQ Option Shuffling : Yes Is Question Mandatory : No**

**Correct Marks : 4 Wrong Marks : 1**

m ची पूर्णांकी मूल्ये, ज्यासाठी  $3x + 4y = 9$  आणि  $y = mx + 1$  या रेषांचा छेद बिंदूचा भुज (abscissa) सुद्धा एक पूर्णांक आहे, त्याची संख्या \_\_\_\_\_ आहे.

**Options :**

86435115905. 0

86435115906. 1

86435115907. 2

86435115908. 3

**Question Number : 78 Question Id : 8643515298 Question Type : MCQ Option Shuffling : Yes Is Question Mandatory : No**

**Correct Marks : 4 Wrong Marks : 1**

The equation of one of the straight lines which passes through the point (1, 3) and makes an angle  $\tan^{-1}(\sqrt{2})$  with the straight line,  $y + 1 = 3\sqrt{2}x$  is :

**Options :**

86435115909.  $4\sqrt{2}x + 5y - (15 + 4\sqrt{2}) = 0$ 86435115910.  $4\sqrt{2}x - 5y - (5 + 4\sqrt{2}) = 0$ 86435115911.  $5\sqrt{2}x + 4y - (15 + 4\sqrt{2}) = 0$ 86435115912.  $4\sqrt{2}x + 5y - 4\sqrt{2} = 0$ 

**Question Number : 78 Question Id : 8643515298 Question Type : MCQ Option Shuffling : Yes Is Question Mandatory : No**

**Correct Marks : 4 Wrong Marks : 1**



(1, 3) या बिंदूमधून जाणाऱ्या आणि  $y + 1 = 3\sqrt{2}x$  या सरळ रेषेला  $\tan^{-1}(\sqrt{2})$  कोन करणाऱ्या रेषांमधील एका सरळ रेषेचे समीकरण \_\_\_\_\_ आहे.

**Options :**

86435115909.  $4\sqrt{2}x + 5y - (15 + 4\sqrt{2}) = 0$

86435115910.  $4\sqrt{2}x - 5y - (5 + 4\sqrt{2}) = 0$

86435115911.  $5\sqrt{2}x + 4y - (15 + 4\sqrt{2}) = 0$

86435115912.  $4\sqrt{2}x + 5y - 4\sqrt{2} = 0$

**Question Number : 79 Question Id : 8643515299 Question Type : MCQ Option Shuffling : Yes Is Question Mandatory : No**

**Correct Marks : 4 Wrong Marks : 1**

The solutions of the equation

$$\begin{vmatrix} 1 + \sin^2 x & \sin^2 x & \sin^2 x \\ \cos^2 x & 1 + \cos^2 x & \cos^2 x \\ 4 \sin 2x & 4 \sin 2x & 1 + 4 \sin 2x \end{vmatrix} = 0, (0 < x < \pi), \text{ are :}$$

**Options :**

86435115913.  $\frac{\pi}{6}, \frac{5\pi}{6}$

86435115914.  $\frac{5\pi}{12}, \frac{7\pi}{12}$

86435115915.  $\frac{7\pi}{12}, \frac{11\pi}{12}$

86435115916.  $\frac{\pi}{12}, \frac{\pi}{6}$

**Question Number : 79 Question Id : 8643515299 Question Type : MCQ Option Shuffling : Yes Is Question Mandatory : No**

**Correct Marks : 4 Wrong Marks : 1**

$$\begin{vmatrix} 1 + \sin^2 x & \sin^2 x & \sin^2 x \\ \cos^2 x & 1 + \cos^2 x & \cos^2 x \\ 4 \sin 2x & 4 \sin 2x & 1 + 4 \sin 2x \end{vmatrix} = 0, (0 < x < \pi),$$

या समीकरणाच्या उकली \_\_\_\_\_ आहेत.

**Options :**

86435115913.  $\frac{\pi}{6}, \frac{5\pi}{6}$

86435115914.  $\frac{5\pi}{12}, \frac{7\pi}{12}$

86435115915.  $\frac{7\pi}{12}, \frac{11\pi}{12}$

86435115916.  $\frac{\pi}{12}, \frac{\pi}{6}$

**Question Number : 80 Question Id : 8643515300 Question Type : MCQ Option Shuffling : Yes Is Question Mandatory : No**

**Correct Marks : 4 Wrong Marks : 1**

A vector  $\vec{a}$  has components  $3p$  and  $1$  with respect to a rectangular cartesian system. This system is rotated through a certain angle about the origin in the counter clockwise sense. If, with respect to new system,  $\vec{a}$  has components  $p + 1$  and  $\sqrt{10}$ , then a value of  $p$  is equal to :

**Options :**

86435115917.  $1$

86435115918.  $-1$

86435115919.  $\frac{4}{5}$

86435115920.  $-\frac{5}{4}$

**Question Number : 80 Question Id : 8643515300 Question Type : MCQ Option Shuffling : Yes Is**

**Question Mandatory : No**

**Correct Marks : 4 Wrong Marks : 1**

एक आयताकार निर्देशक प्रणालीच्या संदर्भात एक सदिश  $\vec{a}$  चा घटक  $3p$  आणि  $1$  आहे. या प्रणालीला आरंभबिंदूच्या संदर्भात घड्याळ्याच्या काट्याच्या दिशेने (clockwise sense) एक विशिष्ट कोनापर्यंत फिरविले जाते. जर नवीन प्रणालीच्या संदर्भात  $\vec{a}$  चा घटक  $p+1$  आणि  $\sqrt{10}$  आहे, तर  $p$  चे मूल्य बरोबर \_\_\_\_\_ आहे.

**Options :**

86435115917.  $1$

86435115918.  $-1$

86435115919.  $\frac{4}{5}$

86435115920.  $-\frac{5}{4}$

## Mathematics Section B

<b>Section Id :</b>	864351354
<b>Section Number :</b>	6
<b>Section type :</b>	Online
<b>Mandatory or Optional :</b>	Mandatory
<b>Number of Questions :</b>	10
<b>Number of Questions to be attempted :</b>	5
<b>Section Marks :</b>	20
<b>Mark As Answered Required? :</b>	Yes
<b>Sub-Section Number :</b>	1
<b>Sub-Section Id :</b>	864351354
<b>Question Shuffling Allowed :</b>	Yes

**Question Number : 81 Question Id : 8643515301 Question Type : SA**

**Correct Marks : 4 Wrong Marks : 0**

Let  $z_1, z_2$  be the roots of the equation  $z^2 + az + 12 = 0$  and  $z_1, z_2$  form an equilateral triangle with origin. Then, the value of  $|a|$  is \_\_\_\_\_.

**Response Type :** Numeric

**Evaluation Required For SA :** Yes

**Show Word Count :** Yes

**Answers Type :** Equal

**Text Areas :** PlainText

**Possible Answers :**

100

**Question Number : 81 Question Id : 8643515301 Question Type : SA**

**Correct Marks : 4 Wrong Marks : 0**

समजा  $z^2 + az + 12 = 0$  या समीकरणाची  $z_1, z_2$  ही मूळे आहेत आणि आरंभबिंदू सोबत  $z_1, z_2$  एक समद्विभुज त्रिकोण तयार करतो. तर  $|a|$  चे मूल्य \_\_\_\_\_ आहे.

**Response Type :** Numeric

**Evaluation Required For SA :** Yes

**Show Word Count :** Yes

**Answers Type :** Equal

**Text Areas :** PlainText

**Possible Answers :**

100

**Question Number : 82 Question Id : 8643515302 Question Type : SA**

**Correct Marks : 4 Wrong Marks : 0**

Let  $f(x)$  and  $g(x)$  be two functions satisfying  $f(x^2) + g(4-x) = 4x^3$  and  $g(4-x) + g(x) = 0$ , then

the value of  $\int_{-4}^4 f(x^2) dx$  is \_\_\_\_\_.

**Response Type :** Numeric

**Evaluation Required For SA :** Yes

**Show Word Count :** Yes

**Answers Type :** Equal

**Text Areas :** PlainText

**Possible Answers :**

100

**Question Number : 82 Question Id : 8643515302 Question Type : SA**

**Correct Marks : 4 Wrong Marks : 0**

समजा  $f(x)$  आणि  $g(x)$  ही दोन फले आहेत, ही फले  $f(x^2) + g(4-x) = 4x^3$  आणि  $g(4-x) + g(x) = 0$  याचे

समाधान करते, तर  $\int_{-4}^4 f(x^2)dx$  चे मूल्य \_\_\_\_\_ आहे.

**Response Type :** Numeric

**Evaluation Required For SA :** Yes

**Show Word Count :** Yes

**Answers Type :** Equal

**Text Areas :** PlainText

**Possible Answers :**

100

**Question Number :** 83 **Question Id :** 8643515303 **Question Type :** SA

**Correct Marks :** 4 **Wrong Marks :** 0

If  $f(x) = \int \frac{5x^8 + 7x^6}{(x^2 + 1 + 2x^7)^2} dx$ , ( $x \geq 0$ ),  $f(0) = 0$  and  $f(1) = \frac{1}{K}$ , then the value of K is

\_\_\_\_\_.

**Response Type :** Numeric

**Evaluation Required For SA :** Yes

**Show Word Count :** Yes

**Answers Type :** Equal

**Text Areas :** PlainText

**Possible Answers :**

100

**Question Number :** 83 **Question Id :** 8643515303 **Question Type :** SA

**Correct Marks :** 4 **Wrong Marks :** 0

जर  $f(x) = \int \frac{5x^8 + 7x^6}{(x^2 + 1 + 2x^7)^2} dx$ , ( $x \geq 0$ ),  $f(0) = 0$  आणि  $f(1) = \frac{1}{K}$ , तर K चे मूल्य \_\_\_\_\_

आहे.

**Response Type :** Numeric

**Evaluation Required For SA :** Yes

**Show Word Count :** Yes

**Answers Type :** Equal

**Text Areas :** PlainText

**Possible Answers :**

100

**Question Number : 84 Question Id : 8643515304 Question Type : SA**

**Correct Marks : 4 Wrong Marks : 0**

A square ABCD has all its vertices on the curve  $x^2y^2 = 1$ . The midpoints of its sides also lie on the same curve. Then, the square of area of ABCD is \_\_\_\_\_.

**Response Type : Numeric**

**Evaluation Required For SA : Yes**

**Show Word Count : Yes**

**Answers Type : Equal**

**Text Areas : PlainText**

**Possible Answers :**

100

**Question Number : 84 Question Id : 8643515304 Question Type : SA**

**Correct Marks : 4 Wrong Marks : 0**

एका चौरस ABCD चे सर्व शिरोबिंदू  $x^2y^2 = 1$  या वक्रावर आहेत. त्याच्या बाजूंचे मध्यबिंदू सुद्धा याच वक्रावर आहेत. तर चौरस ABCD च्या क्षेत्रफळाचा वर्ग \_\_\_\_\_ आहे.

**Response Type : Numeric**

**Evaluation Required For SA : Yes**

**Show Word Count : Yes**

**Answers Type : Equal**

**Text Areas : PlainText**

**Possible Answers :**

100

**Question Number : 85 Question Id : 8643515305 Question Type : SA**

**Correct Marks : 4 Wrong Marks : 0**

Let the plane  $ax + by + cz + d = 0$  bisect the line joining the points  $(4, -3, 1)$  and  $(2, 3, -5)$  at the right angles. If  $a, b, c, d$  are integers, then the minimum value of  $(a^2 + b^2 + c^2 + d^2)$  is \_\_\_\_\_.

**Response Type : Numeric**

**Evaluation Required For SA : Yes**

**Show Word Count : Yes**

**Answers Type : Equal**

**Text Areas : PlainText**

**Possible Answers :**

100

**Question Number : 85 Question Id : 8643515305 Question Type : SA**

**Correct Marks : 4 Wrong Marks : 0**

समजा  $(4, -3, 1)$  आणि  $(2, 3, -5)$  या बिंदूंना जोडणाऱ्या रेषेला  $ax + by + cz + d = 0$  हे प्रतल काटकोनांमध्ये दुभागत आहे. जर  $a, b, c, d$  हे पूर्णांक आहेत, तर  $(a^2 + b^2 + c^2 + d^2)$  चे किमान मूल्य (minimum value) \_\_\_\_\_ आहे.

**Response Type :** Numeric

**Evaluation Required For SA :** Yes

**Show Word Count :** Yes

**Answers Type :** Equal

**Text Areas :** PlainText

**Possible Answers :**

100

**Question Number :** 86 **Question Id :** 8643515306 **Question Type :** SA

**Correct Marks :** 4 **Wrong Marks :** 0

The equation of the planes parallel to the plane  $x - 2y + 2z - 3 = 0$  which are at unit distance from the point  $(1, 2, 3)$  is  $ax + by + cz + d = 0$ . If  $(b - d) = K(c - a)$ , then the positive value of  $K$  is \_\_\_\_\_.

**Response Type :** Numeric

**Evaluation Required For SA :** Yes

**Show Word Count :** Yes

**Answers Type :** Equal

**Text Areas :** PlainText

**Possible Answers :**

100

**Question Number :** 86 **Question Id :** 8643515306 **Question Type :** SA

**Correct Marks :** 4 **Wrong Marks :** 0

$x - 2y + 2z - 3 = 0$  या प्रतलाला समांतर असणारे  $(1, 2, 3)$  या बिंदू पासून एकक अंतरावर असणाऱ्या प्रतलांचे समीकरण  $ax + by + cz + d = 0$  आहे. जर  $(b - d) = K(c - a)$ , तर  $K$  चे धन मूल्य (positive value) \_\_\_\_\_ आहे.

**Response Type :** Numeric

**Evaluation Required For SA :** Yes

**Show Word Count :** Yes

**Answers Type :** Equal

**Text Areas :** PlainText

**Possible Answers :**

100

**Question Number :** 87 **Question Id :** 8643515307 **Question Type :** SA

**Correct Marks :** 4 **Wrong Marks :** 0

The mean age of 25 teachers in a school is 40 years. A teacher retires at the age of 60 years and a new teacher is appointed in his place. If the mean age of the teachers in this school now is 39 years, then the age (in years) of the newly appointed teacher is \_\_\_\_\_.

**Response Type :** Numeric

**Evaluation Required For SA :** Yes

**Show Word Count :** Yes

**Answers Type :** Equal

**Text Areas :** PlainText

**Possible Answers :**

100

**Question Number : 87 Question Id : 8643515307 Question Type : SA**

**Correct Marks : 4 Wrong Marks : 0**

एका शाळेतील 25 शिक्षकांच्या वयांचे मध्य 40 वर्षे आहे. एक शिक्षक 60 व्या वर्षी सेवानिवृत्त होत आहेत आणि एका नवीन शिक्षकाची नियुक्ती त्या जागी झाली आहे. जर आता त्या शाळेमध्ये शिक्षकांच्या वयाचे मध्य 39 वर्षे आहे, तर नवीन नियुक्त केलेल्या शिक्षकाचे वय (वर्षी मध्ये) \_\_\_\_\_ आहे.

**Response Type :** Numeric

**Evaluation Required For SA :** Yes

**Show Word Count :** Yes

**Answers Type :** Equal

**Text Areas :** PlainText

**Possible Answers :**

100

**Question Number : 88 Question Id : 8643515308 Question Type : SA**

**Correct Marks : 4 Wrong Marks : 0**

The number of times the digit 3 will be written when listing the integers from 1 to 1000 is \_\_\_\_\_.

**Response Type :** Numeric

**Evaluation Required For SA :** Yes

**Show Word Count :** Yes

**Answers Type :** Equal

**Text Areas :** PlainText

**Possible Answers :**

100

**Question Number : 88 Question Id : 8643515308 Question Type : SA**

**Correct Marks : 4 Wrong Marks : 0**

1 ते 1000 पूर्णांक क्रमाने लिहीत असताना 3 हा अंक \_\_\_\_\_ वेळा लिहीला जातो.



**Response Type :** Numeric

**Evaluation Required For SA :** Yes

**Show Word Count :** Yes

**Answers Type :** Equal

**Text Areas :** PlainText

**Possible Answers :**

100

**Question Number :** 89 **Question Id :** 8643515309 **Question Type :** SA

**Correct Marks :** 4 **Wrong Marks :** 0

The missing value in the following figure is \_\_\_\_\_.

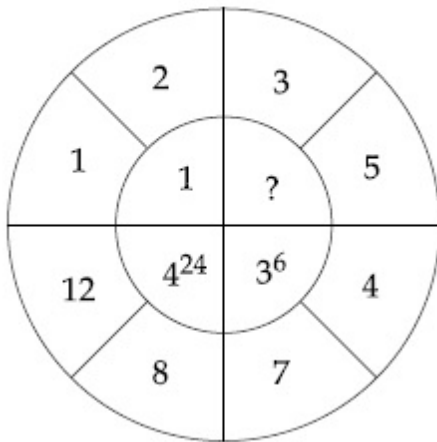

**Response Type :** Numeric

**Evaluation Required For SA :** Yes

**Show Word Count :** Yes

**Answers Type :** Equal

**Text Areas :** PlainText

**Possible Answers :**

100

**Question Number :** 89 **Question Id :** 8643515309 **Question Type :** SA

**Correct Marks :** 4 **Wrong Marks :** 0

खाली दिलेल्या आकृतीमध्ये अनुपस्थित मूल्य (missing value) \_\_\_\_\_ आहे.

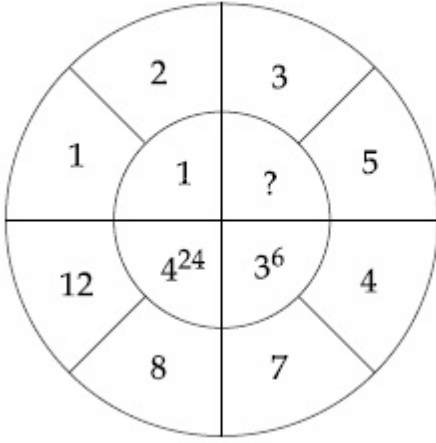

**Response Type :** Numeric

**Evaluation Required For SA :** Yes

**Show Word Count :** Yes

**Answers Type :** Equal

**Text Areas :** PlainText

**Possible Answers :**

100

**Question Number :** 90 **Question Id :** 8643515310 **Question Type :** SA

**Correct Marks :** 4 **Wrong Marks :** 0

The number of solutions of the equation  $|\cot x| = \cot x + \frac{1}{\sin x}$  in the interval  $[0, 2\pi]$  is

\_\_\_\_\_.

**Response Type :** Numeric

**Evaluation Required For SA :** Yes

**Show Word Count :** Yes

**Answers Type :** Equal

**Text Areas :** PlainText

**Possible Answers :**

100

**Question Number :** 90 **Question Id :** 8643515310 **Question Type :** SA

**Correct Marks :** 4 **Wrong Marks :** 0

$|\cot x| = \cot x + \frac{1}{\sin x}$  या समीकरणाचे  $[0, 2\pi]$  या अंतरालामधील उकलिली संख्या \_\_\_\_\_ आहे.

**Response Type :** Numeric

**Evaluation Required For SA :** Yes

**Show Word Count :** Yes

**Answers Type :** Equal

**Text Areas :** PlainText

**Possible Answers :**

100