

Andhra Pradesh State Council of Higher Education

Notations :

- 1.Options shown in green color and with ✓ icon are correct.
- 2.Options shown in red color and with ✗ icon are incorrect.

Question Paper Name :	Computer Science and Information Technology 29th May 2024 Shift 2
Duration :	120
Total Marks :	120
Display Marks:	No
Share Answer Key With Delivery Engine :	Yes
Calculator :	None
Magnifying Glass Required? :	No
Ruler Required? :	No
Eraser Required? :	No
Scratch Pad Required? :	No
Rough Sketch/Notepad Required? :	No
Protractor Required? :	No
Show Watermark on Console? :	Yes
Highlighter :	No
Auto Save on Console?	Yes
Change Font Color :	No
Change Background Color :	No
Change Theme :	No
Help Button :	No
Show Reports :	No

Show Progress Bar :	No
Is this Group for Examiner? :	No
Examiner permission :	Cant View
Show Progress Bar? :	No

Computer Science and Information Technology

Section Id :	33300846
Section Number :	1
Mandatory or Optional :	Mandatory
Number of Questions :	120
Section Marks :	120
Enable Mark as Answered Mark for Review and Clear Response :	Yes
Maximum Instruction Time :	0
Is Section Default? :	null

Question Number : 1 Question Id : 3330085401 Display Question Number : Yes Is Question Mandatory : No Calculator : None Response Time : N.A Think Time : N.A Minimum Instruction Time : 0

The number of multiplications needed to find x^{32} when x is given, is

Options :

1. ✘ 32

2. ✘ 31

3. ✔ 5

4. ✘ 8

Question Number : 2 Question Id : 3330085402 Display Question Number : Yes Is Question Mandatory : No Calculator : None Response Time : N.A Think Time : N.A Minimum Instruction Time : 0

How many terms will be there in the expansion of $(x + y + z)^5$?

Options :

1. ✔ 21

2. ✘ 15

3. ✘ 6

4. ✘ 10

Question Number : 3 Question Id : 3330085403 Display Question Number : Yes Is Question Mandatory : No Calculator : None Response Time : N.A Think Time : N.A Minimum Instruction Time : 0

How many 5-digit numbers can be formed with the digits 0, 1, 2, 3, 4, with no digit being repeated?

Options :

1. ✘ 120

2. ✘ 24

3. ✔ 96

4. ✘ 5

Question Number : 4 Question Id : 3330085404 Display Question Number : Yes Is Question Mandatory : No Calculator : None Response Time : N.A Think Time : N.A Minimum Instruction Time : 0

What is the generating function for a_r where a_r is the number of integral solutions for the equation $a + b + c = r$ with $0 \leq a, b, c \leq 3$?

Options :

1. ✔ $(1 + x + x^2 + x^3)^3$

2. ✘ $(1 + x + x^2 + x^3 \dots \dots \dots + x^r)^r$

3. ✘ $(1 + x + x^2 + x^3)^r$

4. ✘ $(1 + x + x^2 + x^3 \dots \dots \dots + x^r)^3$

Question Number : 5 Question Id : 3330085405 Display Question Number : Yes Is Question Mandatory : No Calculator : None Response Time : N.A Think Time : N.A Minimum Instruction

Time : 0

What is the value of $f(5)$ where $f(n)$ is recursively defined as $f(n) = n*(n-1)$ for $n > 1$ and $f(1) = 2$?

Options :

1. ✘ 5

2. ✘ 120

3. ✘ 0

4. ✔ 240

Question Number : 6 Question Id : 3330085406 Display Question Number : Yes Is Question Mandatory : No Calculator : None Response Time : N.A Think Time : N.A Minimum Instruction

Time : 0

What is the coefficient of x^{10} in the expansion of the generating function $(1 + x + x^2 + x^3 + \dots)^2$

Options :

1. ✘ 1

2. ✘ 10

3. ✘ 2

4. ✓ 11

Question Number : 7 Question Id : 3330085407 Display Question Number : Yes Is Question Mandatory : No Calculator : None Response Time : N.A Think Time : N.A Minimum Instruction Time : 0

If m parallel lines are intersected by n parallel lines then how many parallelograms are formed?

Options :

1. ✗ $m*n$

2. ✗ $m*n/4$

3. ✓ $m*n*(m-1)*(n-1)/4$

4. ✗ $(m-1)*(n-1)$

Question Number : 8 Question Id : 3330085408 Display Question Number : Yes Is Question Mandatory : No Calculator : None Response Time : N.A Think Time : N.A Minimum Instruction Time : 0

The number of subsets of a set consisting of 10 elements is

Options :

1. ✗ $10!$

2. ✗ 11

3. ✘ 12

4. ✔ 2^{10}

Question Number : 9 Question Id : 3330085409 Display Question Number : Yes Is Question Mandatory : No Calculator : None Response Time : N.A Think Time : N.A Minimum Instruction Time : 0

What are the in-degree and out-degree of the vertex 4 ?

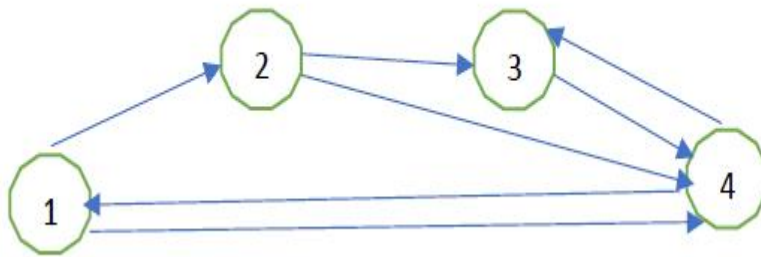

Options :

1. ✘ 1 and 3

2. ✘ 2 and 2

3. ✔ 3 and 2

4. ✘ 1 and 4

Question Number : 10 Question Id : 3330085410 Display Question Number : Yes Is Question

Mandatory : No Calculator : None Response Time : N.A Think Time : N.A Minimum Instruction

Time : 0

Which of the following statements is true?

Options :

1. ✘ Some trees are graphs
2. ✘ All graphs are trees
3. ✔ All trees are graphs
4. ✘ No tree is a graph

Question Number : 11 Question Id : 3330085411 Display Question Number : Yes Is Question Mandatory : No Calculator : None Response Time : N.A Think Time : N.A Minimum Instruction Time : 0

A graph has n vertices and e edges. What is the number of vertices in the spanning tree of that graph?

Options :

1. ✘ $|n - e|$
2. ✘ $|n - e + 1|$
3. ✔ n
4. ✘ e

Question Number : 12 Question Id : 3330085412 Display Question Number : Yes Is Question Mandatory : No Calculator : None Response Time : N.A Think Time : N.A Minimum Instruction Time : 0

What is the chromatic number of a bipartite graph?

Options :

1. ✘ 1

2. ✔ 2

3. ✘ 3

4. ✘ 4

Question Number : 13 Question Id : 3330085413 Display Question Number : Yes Is Question Mandatory : No Calculator : None Response Time : N.A Think Time : N.A Minimum Instruction Time : 0

How many edges will a tree with n vertices have?

Options :

1. ✘ $\lceil n/2 \rceil$

2. ✘ n

3. ✘ $2*n$

4. ✓ $n - 1$

Question Number : 14 Question Id : 3330085414 Display Question Number : Yes Is Question Mandatory : No Calculator : None Response Time : N.A Think Time : N.A Minimum Instruction Time : 0

What is the minimum number of colours required to colour the following graph?

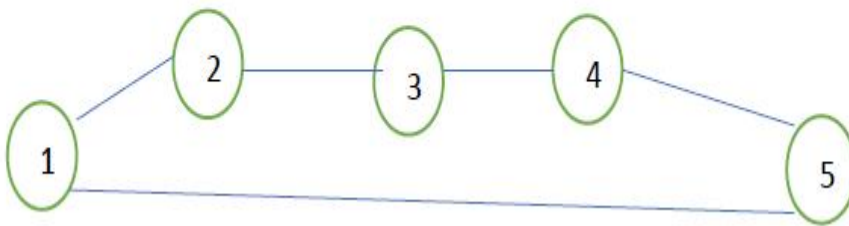

Options :

1. ✗ 1

2. ✗ 2

3. ✓ 3

4. ✗ 4

Question Number : 15 Question Id : 3330085415 Display Question Number : Yes Is Question Mandatory : No Calculator : None Response Time : N.A Think Time : N.A Minimum Instruction Time : 0

Which of the following statements is not true?

Options :

1. ✘ The number of vertices of any two isomorphic graphs is same
2. ✘ The number of edges of any two isomorphic graphs is same
3. ✘ The number of vertices and the number of edges of any two isomorphic graphs are same
4. ✔ The difference between the number of edges of any two isomorphic graphs must be one.

Question Number : 16 Question Id : 3330085416 Display Question Number : Yes Is Question Mandatory : No Calculator : None Response Time : N.A Think Time : N.A Minimum Instruction Time : 0

If P is false then what is the value of the proposition $(P \rightarrow Q) \rightarrow R$?

Options :

1. ✘ P
2. ✘ Q
3. ✔ R
4. ✘ True

Question Number : 17 Question Id : 3330085417 Display Question Number : Yes Is Question Mandatory : No Calculator : None Response Time : N.A Think Time : N.A Minimum Instruction Time : 0

The proposition $\neg P \cup Q$ is equivalent to which of the following?

Options :

1. ✘ $P \cap \neg Q$

2. ✔ $P \rightarrow Q$

3. ✘ $Q \rightarrow P$

4. ✘ $Q \cap P$

Question Number : 18 Question Id : 3330085418 Display Question Number : Yes Is Question Mandatory : No Calculator : None Response Time : N.A Think Time : N.A Minimum Instruction Time : 0

If the following four statements are presented, then which of them is true?

- (a) The number of false statements here is one.
- (b) The number of false statements here is two.
- (c) The number of false statements here is three.
- (d) The number of false statements here is four.

Options :

1. ✘ (a)

2. ✘ (b)

3. ✔ (c)

4. ✘ (d)

Question Number : 19 Question Id : 3330085419 Display Question Number : Yes Is Question Mandatory : No Calculator : None Response Time : N.A Think Time : N.A Minimum Instruction Time : 0

What is the 2's complement of 1010 ?

Options :

1. ✔ 0110

2. ✘ 1001

3. ✘ 1011

4. ✘ 0101

Question Number : 20 Question Id : 3330085420 Display Question Number : Yes Is Question Mandatory : No Calculator : None Response Time : N.A Think Time : N.A Minimum Instruction Time : 0

Which of the following is a tautology?

Options :

1. ✘ $(P \rightarrow Q) \rightarrow (Q \rightarrow P)$

2. ✔ $(P \cap Q) \rightarrow (P \cup Q)$

3. ✘ $(P \cup Q) \rightarrow (Q \cap P)$

4. ✘ $(P \cap Q) \rightarrow (\neg P)$

Question Number : 21 Question Id : 3330085421 Display Question Number : Yes Is Question Mandatory : No Calculator : None Response Time : N.A Think Time : N.A Minimum Instruction Time : 0

A person wishes to make up as many different parties as he can out of 50 friends. Each party consists of the same number of friends. How many should be invited at a time?

Options :

1. ✔ 25

2. ✘ 50

3. ✘ 30

4. ✘ 49

Question Number : 22 Question Id : 3330085422 Display Question Number : Yes Is Question Mandatory : No Calculator : None Response Time : N.A Think Time : N.A Minimum Instruction Time : 0

The number of 1's in the binary representation of $13 \cdot 16^3 + 11 \cdot 16^2 + 9 \cdot 16 + 3$

Options :

1. ✘ 9

2. ✘ 8

3. ✔ 10

4. ✘ 12

Question Number : 23 Question Id : 3330085423 Display Question Number : Yes Is Question Mandatory : No Calculator : None Response Time : N.A Think Time : N.A Minimum Instruction Time : 0

A flip-flop circuit can be used for

Options :

1. ✔ Counting

2. ✘ Synchronization

3. ✘ Rectification

4. ✘ Demodulation

Question Number : 24 Question Id : 3330085424 Display Question Number : Yes Is Question Mandatory : No Calculator : None Response Time : N.A Think Time : N.A Minimum Instruction Time : 0

The number of full adders in a four bit parallel adder is

Options :

1. ✘ Two

2. ✘ Three

3. ✔ Four

4. ✘ Five

Question Number : 25 Question Id : 3330085425 Display Question Number : Yes Is Question Mandatory : No Calculator : None Response Time : N.A Think Time : N.A Minimum Instruction Time : 0

Which of the following is not a register?

Options :

1. ✘ Accumulator

2. ✔ Cursor

3. ✘ Stack pointer

4. ✘ Program counter

Question Number : 26 Question Id : 3330085426 Display Question Number : Yes Is Question Mandatory : No Calculator : None Response Time : N.A Think Time : N.A Minimum Instruction Time : 0

The binary equivalent of $(222)_3$ is

Options :

1. ✓ 11010

2. ✗ 11001

3. ✗ 10101

4. ✗ 11101

Question Number : 27 Question Id : 3330085427 Display Question Number : Yes Is Question Mandatory : No Calculator : None Response Time : N.A Think Time : N.A Minimum Instruction Time : 0

The Boolean expression $AB + A\bar{B} + A\bar{C} + \bar{A}C + \bar{A}D + AD$ is independent of which of the following variables?

Options :

1. ✗ A

2. ✓ B

3. ✗ C

4. ✗ D

Question Number : 28 Question Id : 3330085428 Display Question Number : Yes Is Question Mandatory : No Calculator : None Response Time : N.A Think Time : N.A Minimum Instruction Time : 0

The addressing mode used in the instruction PUSH B is

Options :

1. ✘ Direct
2. ✘ Immediate
3. ✘ Register
4. ✔ Register indirect

Question Number : 29 Question Id : 3330085429 Display Question Number : Yes Is Question Mandatory : No Calculator : None Response Time : N.A Think Time : N.A Minimum Instruction Time : 0

The minimum time delay between initiation of two independent memory operations is called

Options :

1. ✔ Cycle time
2. ✘ Access time
3. ✘ Transfer time
4. ✘ Latency

Question Number : 30 Question Id : 3330085430 Display Question Number : Yes Is Question

Mandatory : No Calculator : None Response Time : N.A Think Time : N.A Minimum Instruction Time : 0

What is the output of the following C program?

```
#define sqr(x) (x*x)
main()
{
    int a, b = 13;
    a = sqr(b + 12);
    printf("%d", a);
}
```

Options :

1. ✘ 625

2. ✔ 181

3. ✘ 225

4. ✘ 192

Question Number : 31 Question Id : 3330085431 Display Question Number : Yes Is Question Mandatory : No Calculator : None Response Time : N.A Think Time : N.A Minimum Instruction Time : 0

What is the meaning of the following declaration in C?

```
int *(*p)(int (*a)[]);
```

Options :

1. ✔ Represents a pointer to a function that accepts a pointer to an array of integers as an argument and returns a pointer to an integer.

2. ✘ Represents a function that accepts a pointer to an array of integers as an argument and returns a pointer to an integer.

3. ✘ Represents a pointer to a function that accepts a function to an array of integers as an argument and returns a pointer to an integer.

4. ✘ Represents a pointer to a function that accepts a pointer to function to an array of integers as an argument and returns a pointer to an integer.

Question Number : 32 Question Id : 3330085432 Display Question Number : Yes Is Question Mandatory : No Calculator : None Response Time : N.A Think Time : N.A Minimum Instruction Time : 0

What is the data structure used for converting a recursive program into the non-recursive version of the same?

Options :

1. ✔ Stack

2. ✘ Queue

3. ✘ Tree

4. ✘ Graph

Question Number : 33 Question Id : 3330085433 Display Question Number : Yes Is Question Mandatory : No Calculator : None Response Time : N.A Think Time : N.A Minimum Instruction

Time : 0

What is the value of x after the execution of the following C language statement?

$x = -11 \% -3;$

Options :

1. ✘ 2

2. ✘ 4

3. ✔ -2

4. ✘ 1

Question Number : 34 Question Id : 3330085434 Display Question Number : Yes Is Question Mandatory : No Calculator : None Response Time : N.A Think Time : N.A Minimum Instruction

Time : 0

In C language what is the value of x –'0' where x is declared as char x = '5';

Options :

1. ✔ 5

2. ✘ 4

3. ✘ 50

4. ✘ 53

Question Number : 35 Question Id : 3330085435 Display Question Number : Yes Is Question Mandatory : No Calculator : None Response Time : N.A Think Time : N.A Minimum Instruction Time : 0

What is the value of the following C statement when the value of the variable x = 600?

```
tax = ( x < 500 ) ? (( x > 400 ? x*20 : x*10 ) : ( x < 700 ? x*25 : x*30));
```

Options :

1. ✓ 15000

2. ✗ 6000

3. ✗ 12000

4. ✗ 18000

Question Number : 36 Question Id : 3330085436 Display Question Number : Yes Is Question Mandatory : No Calculator : None Response Time : N.A Think Time : N.A Minimum Instruction Time : 0

What is the output of the of the following C- program segment?

```
int j = 7;  
printf(“%d, %d”, j++, j--);
```

Options :

1. ✓ 6, 7

2. ✗ 7, 7

3. ✗ 8, 7

4. ✘ 7, 6

Question Number : 37 Question Id : 3330085437 Display Question Number : Yes Is Question Mandatory : No Calculator : None Response Time : N.A Think Time : N.A Minimum Instruction Time : 0

What is the output of the following C-program?

```
include <stdio.h>
include <math.h>
main()
{
    int sum = 0, n = 1729;
    do {
        sum+ = n%10;
        n= n/10;
    } while (n > 0);
    printf( "%d", sum);
}
```

Options :

1. ✔ 19

2. ✘ 0

3. ✘ 28

4. ✘ 9271

Question Number : 38 Question Id : 3330085438 Display Question Number : Yes Is Question Mandatory : No Calculator : None Response Time : N.A Think Time : N.A Minimum Instruction Time : 0

How much memory is required to store the elements of the array defined as float items[4][5][6];

Options :

1. ✘ 240 bytes

2. ✘ 120 bytes

3. ✔ 480 bytes

4. ✘ 920 bytes

Question Number : 39 Question Id : 3330085439 Display Question Number : Yes Is Question Mandatory : No Calculator : None Response Time : N.A Think Time : N.A Minimum Instruction Time : 0

What is the output of the following piece of C-code?

```
int a[2] = { 13, 31 };  
int *p = a;  
printf(“%d, %d”, *p, *p+1);
```

Options :

1. ✘ 13, 31

2. ✘ 31, 13

3. ✔ 13, 14

4. ✘ 13, 13

Question Number : 40 Question Id : 3330085440 Display Question Number : Yes Is Question Mandatory : No Calculator : None Response Time : N.A Think Time : N.A Minimum Instruction Time : 0

Which header needs to be included, in C, if you are to develop a function which can accept variable number arguments?

Options :

1. ✘ `stdio.h`

2. ✔ `stdarg.h`

3. ✘ `stdvarg.h`

4. ✘ `arg.h`

Question Number : 41 Question Id : 3330085441 Display Question Number : Yes Is Question Mandatory : No Calculator : None Response Time : N.A Think Time : N.A Minimum Instruction Time : 0

What is the maximum number of binary trees possible with 4 nodes?

Options :

1. ✘ 16

2. ✘ 15

3. ✔ 14

4. ✘ 10

Question Number : 42 Question Id : 3330085442 Display Question Number : Yes Is Question Mandatory : No Calculator : None Response Time : N.A Think Time : N.A Minimum Instruction Time : 0

The post-order traversal of a binary tree is F A E K C D H G B. What is its root?

Options :

1. ✘ A

2. ✘ F

3. ✘ C

4. ✔ B

Question Number : 43 Question Id : 3330085443 Display Question Number : Yes Is Question Mandatory : No Calculator : None Response Time : N.A Think Time : N.A Minimum Instruction Time : 0

A one dimensional array has n elements stored from 0^{th} position to $(n-1)^{\text{th}}$ position. How many elements need to be moved to insert an element at p^{th} position of the array?

Options :

1. ✘ $n - p + 1$

2. ✔ $n - p$

3. ✘ n

4. ✘ p

Question Number : 44 Question Id : 3330085444 Display Question Number : Yes Is Question Mandatory : No Calculator : None Response Time : N.A Think Time : N.A Minimum Instruction Time : 0

A full binary tree has n leaf nodes. How many total number of nodes will that tree have?

Options :

1. ✔ $2 * n - 1$

2. ✘ $2^n - 1$

3. ✘ $2 * n$

4. ✘ 2^n

Question Number : 45 Question Id : 3330085445 Display Question Number : Yes Is Question Mandatory : No Calculator : None Response Time : N.A Think Time : N.A Minimum Instruction

Time : 0

Which one of the following statements is true?

Options :

1. ✓ Every stack is a priority queue
2. ✗ A linear queue is empty if $\text{front} = \text{rear}$
3. ✗ A binary tree with n nodes will have $\lfloor n/2 \rfloor$ leaf nodes
4. ✗ A directed acyclic graph is a tree

Question Number : 46 Question Id : 3330085446 Display Question Number : Yes Is Question Mandatory : No Calculator : None Response Time : N.A Think Time : N.A Minimum Instruction Time : 0

The average case time complexity of quick sort is

Options :

1. ✓ $O(n \log n)$
2. ✗ $O(n^2)$
3. ✗ $O(n)$
4. ✗ $O(\log n)$

Question Number : 47 Question Id : 3330085447 Display Question Number : Yes Is Question Mandatory : No Calculator : None Response Time : N.A Think Time : N.A Minimum Instruction Time : 0

The break point of an interrupt during instruction cycle can occur at the end of

Options :

1. ✘ Fetch phase
2. ✘ Decode phase
3. ✘ Any phase
4. ✔ Store result phase

Question Number : 48 Question Id : 3330085448 Display Question Number : Yes Is Question Mandatory : No Calculator : None Response Time : N.A Think Time : N.A Minimum Instruction Time : 0

What is the relationship between clock period(t_c) and propagation delay(t_p) when racing condition occurs in JK flip-flop?

Options :

1. ✘ $t_p < t_c$
2. ✔ $t_c < t_p$
3. ✘ $t_p = t_c$

No relation between tp and tc

4. ✘

Question Number : 49 Question Id : 3330085449 Display Question Number : Yes Is Question Mandatory : No Calculator : None Response Time : N.A Think Time : N.A Minimum Instruction Time : 0

Which among the following consider the iterative approach to software development?

- a. Extreme programming
- b. Agile
- c. Rational Unified Process

Options :

1. ✔ a, b and c

2. ✘ a & b only

3. ✘ a & c only

4. ✘ b & c only

Question Number : 50 Question Id : 3330085450 Display Question Number : Yes Is Question Mandatory : No Calculator : None Response Time : N.A Think Time : N.A Minimum Instruction Time : 0

The following circuit is equivalent to which gate?

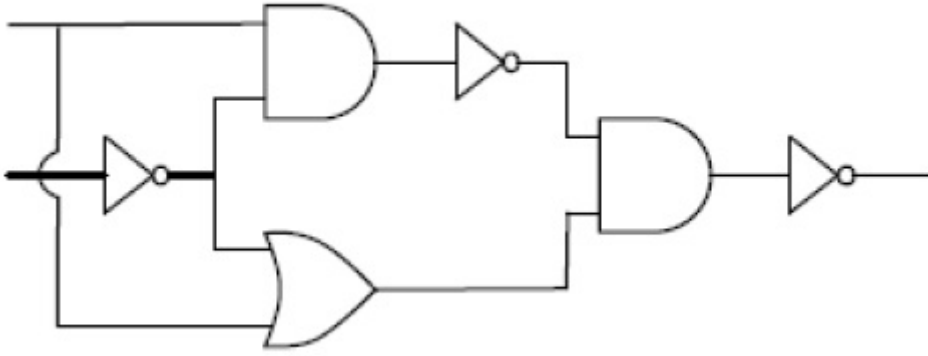

Options :

1. ✓ XOR

2. ✗ XNOR

3. ✗ OR

4. ✗ AND

Question Number : 51 Question Id : 3330085451 Display Question Number : Yes Is Question Mandatory : No Calculator : None Response Time : N.A Think Time : N.A Minimum Instruction Time : 0

The control / training signal generation function in sequential circuit is termed as

Options :

1. ✓ Counter

2. ✗ Programmable register

3. ✘ Decoder

4. ✘ Encoder

Question Number : 52 Question Id : 3330085452 Display Question Number : Yes Is Question Mandatory : No Calculator : None Response Time : N.A Think Time : N.A Minimum Instruction Time : 0

Which of the following problems is an example of backtracking strategy?

Options :

1. ✔ Knight's tour

2. ✘ Towers's Hanoi

3. ✘ Travelling salesman's

4. ✘ Matrix multiplication

Question Number : 53 Question Id : 3330085453 Display Question Number : Yes Is Question Mandatory : No Calculator : None Response Time : N.A Think Time : N.A Minimum Instruction Time : 0

Which of the following is not an algorithmic strategy?

Options :

1. ✘ Dynamic programming

2. ✘ Greedy method

3. ✔ Secant method

4. ✘ Branch and bound

Question Number : 54 Question Id : 3330085454 Display Question Number : Yes Is Question Mandatory : No Calculator : None Response Time : N.A Think Time : N.A Minimum Instruction Time : 0

The travelling salesman's is an example of which of the following class of problems?

Options :

1. ✔ NP-hard

2. ✘ P

3. ✘ C

4. ✘ NP but not NP-hard

Question Number : 55 Question Id : 3330085455 Display Question Number : Yes Is Question Mandatory : No Calculator : None Response Time : N.A Think Time : N.A Minimum Instruction Time : 0

Which of the following is an example of divide and conquer strategy?

Options :

1. ✘ Hashing
2. ✔ Quick sort
3. ✘ Dynamic programming
4. ✘ Primality testing

Question Number : 56 Question Id : 3330085456 Display Question Number : Yes Is Question Mandatory : No Calculator : None Response Time : N.A Think Time : N.A Minimum Instruction Time : 0

Order the following complexities in the increasing order: $O(n^2)$, $O(n^3)$, $O(\log n)$, $O(n \cdot \log n)$

Options :

1. ✘ $O(n^2)$, $O(n^3)$, $O(\log n)$, $O(n \cdot \log n)$
2. ✘ $O(n^3)$, $O(\log n)$, $O(n \cdot \log n)$, $O(n^2)$
3. ✔ $O(\log n)$, $O(n \cdot \log n)$, $O(n^2)$, $O(n^3)$
4. ✘ $O(\log n)$, $O(n^2)$, $O(n \cdot \log n)$, $O(n^3)$

Question Number : 57 Question Id : 3330085457 Display Question Number : Yes Is Question Mandatory : No Calculator : None Response Time : N.A Think Time : N.A Minimum Instruction

Time : 0

Which of the following problems is in P?

Options :

1. ✓ Matrix multiplication
2. ✗ Graph isomorphism
3. ✗ Discrete logarithm
4. ✗ Knapsack problem

Question Number : 58 Question Id : 3330085458 Display Question Number : Yes Is Question Mandatory : No Calculator : None Response Time : N.A Think Time : N.A Minimum Instruction

Time : 0

What is the language L generated by the production rules $SS \rightarrow aSa \mid bSb \mid a \mid b$ of the grammar over the alphabet $\{a, b\}$?

Options :

1. ✗ $L = \{ x \mid x \text{ is a string starting and ending with the same alphabet} \}$
2. ✗ $L = \{ x \mid x \text{ is a string which is not a palindrome} \}$
3. ✗ $L = \{ x \mid x \text{ is a string which is a palindrome of even length} \}$
4. ✓ $L = \{ x \mid x \text{ is a string which is a palindrome of odd length} \}$

Question Number : 59 Question Id : 3330085459 Display Question Number : Yes Is Question Mandatory : No Calculator : None Response Time : N.A Think Time : N.A Minimum Instruction Time : 0

A problem P is known to be NP- complete and Q and R are two problems such that Q is polynomial time reducible to P and P is polynomial time reducible to R. The which one of the following is true?

Options :

1. ✘ Q is NP-complete
2. ✔ R is NP-complete
3. ✘ Q is N-hard
4. ✘ R is NP-hard

Question Number : 60 Question Id : 3330085460 Display Question Number : Yes Is Question Mandatory : No Calculator : None Response Time : N.A Think Time : N.A Minimum Instruction Time : 0

Which one of the following statements is true?

Options :

1. ✘ The intersection of two context free languages is context free
2. ✘ A context free language is accepted by a Deterministic Push Down Automata
3. ✔ The union of two context free languages is context free

4. ✘ The complement of a context free language is context free.

Question Number : 61 Question Id : 3330085461 Display Question Number : Yes Is Question Mandatory : No Calculator : None Response Time : N.A Think Time : N.A Minimum Instruction Time : 0

Which one of the following is not an operating system?

Options :

1. ✔ DB/2

2. ✘ LINUX

3. ✘ OS/2

4. ✘ Android

Question Number : 62 Question Id : 3330085462 Display Question Number : Yes Is Question Mandatory : No Calculator : None Response Time : N.A Think Time : N.A Minimum Instruction Time : 0

Which of the following is not a DBMS?

Options :

1. ✘ DB/2

2. ✔ OS/2

3. ✖ ORACLE

4. ✖ MS-EXCEL

Question Number : 63 Question Id : 3330085463 Display Question Number : Yes Is Question Mandatory : No Calculator : None Response Time : N.A Think Time : N.A Minimum Instruction Time : 0

In a DBMS, a candidate which is not primary key is called

Options :

1. ✖ Super key

2. ✖ Foreign key

3. ✔ Alternate key

4. ✖ Compound key

Question Number : 64 Question Id : 3330085464 Display Question Number : Yes Is Question Mandatory : No Calculator : None Response Time : N.A Think Time : N.A Minimum Instruction Time : 0

In an RDBMS, data is represented as a set of

Options :

1. ✖ Sequences

2. ✓ Tables

3. ✗ Pointers

4. ✗ Queries

Question Number : 65 Question Id : 3330085465 Display Question Number : Yes Is Question Mandatory : No Calculator : None Response Time : N.A Think Time : N.A Minimum Instruction Time : 0

If a relation is in BCNF then it is in

Options :

1. ✓ 3 NF

2. ✗ 4 NF

3. ✗ 5 NF

4. ✗ 6 NF

Question Number : 66 Question Id : 3330085466 Display Question Number : Yes Is Question Mandatory : No Calculator : None Response Time : N.A Think Time : N.A Minimum Instruction Time : 0

Referential integrity refers to which one of the following?

Options :

1. ✘ Primary Key
2. ✘ Super key
3. ✔ Foreign key
4. ✘ Alternate key

Question Number : 67 Question Id : 3330085467 Display Question Number : Yes Is Question Mandatory : No Calculator : None Response Time : N.A Think Time : N.A Minimum Instruction Time : 0

The concept of serializability in a database management system is related to

Options :

1. ✔ Concurrency control
2. ✘ Normalization
3. ✘ E-R models
4. ✘ Symmetric key

Question Number : 68 Question Id : 3330085468 Display Question Number : Yes Is Question Mandatory : No Calculator : None Response Time : N.A Think Time : N.A Minimum Instruction Time : 0

The method of linear probing is related to which one of the following?

Options :

1. ✓ Resolving collisions in hashing
2. ✗ Database recovery
3. ✗ Database security
4. ✗ Concurrency control

Question Number : 69 Question Id : 3330085469 Display Question Number : Yes Is Question Mandatory : No Calculator : None Response Time : N.A Think Time : N.A Minimum Instruction Time : 0

The number of CODD rules which characterize an RDBMS is

Options :

1. ✗ 24
2. ✗ 16
3. ✓ 12
4. ✗ 32

Question Number : 70 Question Id : 3330085470 Display Question Number : Yes Is Question Mandatory : No Calculator : None Response Time : N.A Think Time : N.A Minimum Instruction

Time : 0

Based on the following schema,

sailors (sailor_id, sailpr_name, age);

boats (boat_id, boat_name, colour);

reserves (sailor_id, boat_id, day);

which of the following SQL query gives answer to the statement "All the ages of the sailors whose name begins and ends with B and has at least three characters?"

Options :

1. ✓ `SELECT S.age FROM sailors S WHERE S.sailor_name LIKE 'B_%B';`
2. ✗ `SELECT S.age FROM sailors WHERE S.sailor_name LIKE 'B_%B';`
3. ✗ `SELECT S.age FROM sailors WHERE sailor_name AS CHAR >= 3;`
4. ✗ `SELECT S.age FROM sailors WHERE .sailor_name AS MIN(CHAR) >= 3;`

Question Number : 71 Question Id : 3330085471 Display Question Number : Yes Is Question Mandatory : No Calculator : None Response Time : N.A Think Time : N.A Minimum Instruction

Time : 0

Based on the following schema,

sailors (sailor_id, sailpr_name, age);

boats (boat_id, boat_name, colour);

reserves (sailor_id, boat_id, day);

what does the following SQL query imply?

```
SELECT S.sailor_name FROM sailors S WHERE S.sailor_id IN (SELECT R.sailor_id FROM reserves R WHERE R.boat_id >= 103);
```

Options :

1. ✗ The number of the sailors whose names are same as that of the boat names.

2. ✘ The names of the sailors who are reserved for the boat number 103.
3. ✔ The names of the sailors who have reserved boat number 103.
4. ✘ The names of the sailors who are sailing presently in boat number 103

Question Number : 72 Question Id : 3330085472 Display Question Number : Yes Is Question Mandatory : No Calculator : None Response Time : N.A Think Time : N.A Minimum Instruction Time : 0

Based on the following schema,

sailors (sailor_id, sailor_name, age);

boats (boat_id, boat_name, colour);

reserves (sailor_id, boat_id, day);

what does the following SQL query imply?

```
SELECT S.sailor_name FROM sailors S, boats B, reserves R WHERE S.sailor_id = R.sailor_id AND R.boat_id = B.boat_id AND ( B.colour = 'red' OR B.colour = 'green');
```

Options :

1. ✘ The names of the sailors who are travelling by a red or a green boat.
2. ✘ The names of the sailors who are reserved for the boat number 103.
3. ✘ The names of the sailors who have a red boat but not a green boat.
4. ✔ The names of the sailors who have reserved a red or a green boat.

Question Number : 73 Question Id : 3330085473 Display Question Number : Yes Is Question Mandatory : No Calculator : None Response Time : N.A Think Time : N.A Minimum Instruction Time : 0

Match the following

GROUP-1	GROUP-2
i. Physical layer	a. Segment
ii. Data link layer	b. Datagram
iii. Network layer	c. Message
iv. Transport layer	d. Frame
v. Application layer	e. Bit

Options :

1. ✓ i. – e, ii. – d, iii. – b, iv. – a, v. – c
2. ✗ i. – c, ii. – d, iii. – b, iv. – a, v. – e
3. ✗ i. – e, ii. – d, iii. – a, iv. – b, v. – c
4. ✗ i. – e, ii. – d, iii. – b, iv. – c, v. – a

Question Number : 74 Question Id : 3330085474 Display Question Number : Yes Is Question Mandatory : No Calculator : None Response Time : N.A Think Time : N.A Minimum Instruction Time : 0

In the standard Ethernet, if the maximum propagation time is $25.6\mu\text{s}$, then the minimum size of the frame is

Options :

1. ✓ 64 bytes

2. ✘ 512 bytes

3. ✘ 48 bytes

4. ✘ 6 bytes

Question Number : 75 Question Id : 3330085475 Display Question Number : Yes Is Question Mandatory : No Calculator : None Response Time : N.A Think Time : N.A Minimum Instruction Time : 0

The network topology with highest reliability is

Options :

1. ✔ Mesh topology

2. ✘ Bus topology

3. ✘ Star topology

4. ✘ Ring topology

Question Number : 76 Question Id : 3330085476 Display Question Number : Yes Is Question Mandatory : No Calculator : None Response Time : N.A Think Time : N.A Minimum Instruction Time : 0

Which among the following protocols uses UDP as a transport layer protocol?

a. FTP b. SNMP c. SMTP d. TFTP e. HTTP

Options :

1. ✓ b and d only
2. ✗ a and d only
3. ✗ a, b and d only
4. ✗ c and d only

Question Number : 77 Question Id : 3330085477 Display Question Number : Yes Is Question Mandatory : No Calculator : None Response Time : N.A Think Time : N.A Minimum Instruction Time : 0

End to end connectivity is provided from host to host in which one of the following layers?

Options :

1. ✗ The network layer
2. ✓ The transport layer
3. ✗ The session layer
4. ✗ The data link layer

Question Number : 78 Question Id : 3330085478 Display Question Number : Yes Is Question Mandatory : No Calculator : None Response Time : N.A Think Time : N.A Minimum Instruction

Time : 0

The Hamming distance between 11001011 and 10000111

Options :

1. ✘ 4

2. ✘ 1

3. ✘ 2

4. ✔ 3

Question Number : 79 Question Id : 3330085479 Display Question Number : Yes Is Question Mandatory : No Calculator : None Response Time : N.A Think Time : N.A Minimum Instruction Time : 0

To verify a digital signature, we need the _____.

Options :

1. ✔ Sender's public key

2. ✘ Sender's private key

3. ✘ Receiver's public key

4. ✘ Receiver's private key

Question Number : 80 Question Id : 3330085480 Display Question Number : Yes Is Question Mandatory : No Calculator : None Response Time : N.A Think Time : N.A Minimum Instruction Time : 0

Maximum data rate of a channel for noiseless 3 kHz binary channel is

Options :

1. ✘ 2000 bps
2. ✘ 3000 bps
3. ✔ 6000 bps
4. ✘ 1000 bps

Question Number : 81 Question Id : 3330085481 Display Question Number : Yes Is Question Mandatory : No Calculator : None Response Time : N.A Think Time : N.A Minimum Instruction Time : 0

Which of the following is not a web component element?

Options :

1. ✘ `<shadow>`
2. ✘ `<menu>`
3. ✔ `<content>`
4. ✘ `<element>`

Question Number : 82 Question Id : 3330085482 Display Question Number : Yes Is Question Mandatory : No Calculator : None Response Time : N.A Think Time : N.A Minimum Instruction Time : 0

Which one of the following is commonly used for server side scripting in web development?

Options :

1. ✘ HTML
2. ✘ CSS
3. ✔ PHP
4. ✘ JavaScript

Question Number : 83 Question Id : 3330085483 Display Question Number : Yes Is Question Mandatory : No Calculator : None Response Time : N.A Think Time : N.A Minimum Instruction Time : 0

Statement 1: When dynamic programming is applied to a problem, it takes far less time as compared to other methods that don't take advantage of overlapping subproblems.

Statement 2: A greedy algorithm can be used to solve all the dynamic programming problems.

Options :

1. ✔ Statement 1 is TRUE and Statement 2 is FALSE
2. ✘ Statement 1 is FALSE and Statement 2 is TRUE

3. ✘ Both Statements 1 and 2 are TRUE

4. ✘ Both Statements 1 and 2 are FALSE

Question Number : 84 Question Id : 3330085484 Display Question Number : Yes Is Question Mandatory : No Calculator : None Response Time : N.A Think Time : N.A Minimum Instruction Time : 0

What does <td> stands for, in web programming development?

Options :

1. ✔ Table data

2. ✘ Table directive

3. ✘ Table directory

4. ✘ Table dictionary

Question Number : 85 Question Id : 3330085485 Display Question Number : Yes Is Question Mandatory : No Calculator : None Response Time : N.A Think Time : N.A Minimum Instruction Time : 0

Which font format is used in web pages?

Options :

1. ✘ EOT

2.

✘ SYN

3. ✔ WOFF

4. ✘ SVG

Question Number : 86 Question Id : 3330085486 Display Question Number : Yes Is Question Mandatory : No Calculator : None Response Time : N.A Think Time : N.A Minimum Instruction Time : 0

Telnet is

Options :

1. ✘ Another name for Internet

2. ✔ A utility that can be used for remote login

3. ✘ A protocol used for Fire transfer

4. ✘ A protocol used for communicating voice through mobile phones

Question Number : 87 Question Id : 3330085487 Display Question Number : Yes Is Question Mandatory : No Calculator : None Response Time : N.A Think Time : N.A Minimum Instruction Time : 0

A computer has 24-bit address bus and an instruction format providing 12 bits in the address part. What is the maximum addressable range?

Options :

1. ✓ 2^{24} locations

2. ✗ 2^{12} locations

3. ✗ 2^{36} locations

4. ✗ 2^{48} locations

Question Number : 88 Question Id : 3330085488 Display Question Number : Yes Is Question Mandatory : No Calculator : None Response Time : N.A Think Time : N.A Minimum Instruction Time : 0

In a page segmented system, a virtual address consists of 32 bits of which 12 bits are a displacement, 11 bits are segment number and 9 bits are page number. What is the page size?

Options :

1. ✓ 2^{12} bytes

2. ✗ 2^{23} bytes

3. ✗ 2^{11} bytes

4. ✗ 2^{32} bytes

Question Number : 89 Question Id : 3330085489 Display Question Number : Yes Is Question Mandatory : No Calculator : None Response Time : N.A Think Time : N.A Minimum Instruction Time : 0

Which of the following is essential for converting an infix expression to the postfix form efficiently?

Options :

1. ✓ An operator stack
2. ✗ An operand stack
3. ✗ An operand stack and an operator stack
4. ✗ A parse tree

Question Number : 90 Question Id : 3330085490 Display Question Number : Yes Is Question Mandatory : No Calculator : None Response Time : N.A Think Time : N.A Minimum Instruction Time : 0

What do semaphores do?

Options :

1. ✓ Synchronize critical resources to prevent deadlock
2. ✗ Synchronize critical resources to prevent contention
3. ✗ Used for shutting down computer system

4. ✘ Used to maintain the clock speed of every process

Question Number : 91 Question Id : 3330085491 Display Question Number : Yes Is Question Mandatory : No Calculator : None Response Time : N.A Think Time : N.A Minimum Instruction Time : 0

The memory allocation scheme subject to external fragmentation is

Options :

1. ✔ Segmentation

2. ✘ Swapping

3. ✘ Double buffering

4. ✘ Pure demand paging

Question Number : 92 Question Id : 3330085492 Display Question Number : Yes Is Question Mandatory : No Calculator : None Response Time : N.A Think Time : N.A Minimum Instruction Time : 0

Which one of the following is related to deadlock?

Options :

1. ✘ Dijkstra's algorithm

2. ✔ Banker's algorithm

3. ✘ Prim's algorithm

4. ✘ Kruskal's algorithm

Question Number : 93 Question Id : 3330085493 Display Question Number : Yes Is Question Mandatory : No Calculator : None Response Time : N.A Think Time : N.A Minimum Instruction Time : 0

Which one of the following memory management schemes does not support multiprogramming?

Options :

1. ✔ Single partition allocation

2. ✘ Multiple partition allocation

3. ✘ Paging

4. ✘ Segmentation

Question Number : 94 Question Id : 3330085494 Display Question Number : Yes Is Question Mandatory : No Calculator : None Response Time : N.A Think Time : N.A Minimum Instruction Time : 0

The total time taken by a process to complete execution is called

Options :

1. ✘ Waiting time

2. ✓ Turnaround time

3. ✘ Response time

4. ✘ Throughput

Question Number : 95 Question Id : 3330085495 Display Question Number : Yes Is Question Mandatory : No Calculator : None Response Time : N.A Think Time : N.A Minimum Instruction Time : 0

When all other processes are waiting for one process to get off the CPU, the phenomenon is called

Options :

1. ✘ Starvation

2. ✘ Blocking

3. ✓ Convoy effect

4. ✘ Aging

Question Number : 96 Question Id : 3330085496 Display Question Number : Yes Is Question Mandatory : No Calculator : None Response Time : N.A Think Time : N.A Minimum Instruction Time : 0

Garbage collection deals with

Options :

1. ✘ Reclaiming memory from unused programs
2. ✘ Removing all programs from memory
3. ✔ Reclaiming usable work space
4. ✘ Removing larger programs to accommodate smaller programs

Question Number : 97 Question Id : 3330085497 Display Question Number : Yes Is Question Mandatory : No Calculator : None Response Time : N.A Think Time : N.A Minimum Instruction Time : 0

The term cyclomatic complexity is related to

Options :

1. ✘ Complexity of branch and bound strategy
2. ✔ Software testing
3. ✘ Software maintenance
4. ✘ Complexity of the algorithm in finding the cycles in a graph.

Question Number : 98 Question Id : 3330085498 Display Question Number : Yes Is Question Mandatory : No Calculator : None Response Time : N.A Think Time : N.A Minimum Instruction Time : 0

Assume transaction A holds a shared lock R. If transaction B also requests for a shared lock on R, it will

Options :

1. ✓ Immediately be rejected
2. ✗ Result in a deadlock situation
3. ✗ Immediately be rejected
4. ✗ Be granted as soon as it is released by A

Question Number : 99 Question Id : 3330085499 Display Question Number : Yes Is Question Mandatory : No Calculator : None Response Time : N.A Think Time : N.A Minimum Instruction Time : 0

Consider the following table of arrival and burst time in ms for three processes P0, P1 and P2.

Process	Arrival Time	Burst Time
P0	0	9
P1	1	4
P2	2	9

The pre-emptive shortest job first scheduling algorithm is used. Scheduling is carried out only at arrival or completion of processes. What is the average waiting time for the three processes?

Options :

1. ✗ 7.33 ms
2. ✓ 5 ms
- 3.

✘ 4.33 ms

4. ✘ 6.33 ms

Question Number : 100 Question Id : 3330085500 Display Question Number : Yes Is Question Mandatory : No Calculator : None Response Time : N.A Think Time : N.A Minimum Instruction Time : 0

In a particular bank, a loan can belong to only one customer and a customer can have several loans then the relationship from customer to loans is

Options :

1. ✘ Many to many

2. ✘ Many to one

3. ✘ One to one

4. ✔ One to many

Question Number : 101 Question Id : 3330085501 Display Question Number : Yes Is Question Mandatory : No Calculator : None Response Time : N.A Think Time : N.A Minimum Instruction Time : 0

The number of binary relations on a set with 3 elements is

Options :

1. ✘ 8

2. ✘ 16

3. ✔ 512

4. ✘ 128

Question Number : 102 Question Id : 3330085502 Display Question Number : Yes Is Question Mandatory : No Calculator : None Response Time : N.A Think Time : N.A Minimum Instruction Time : 0

The cut vertex set of the graph is

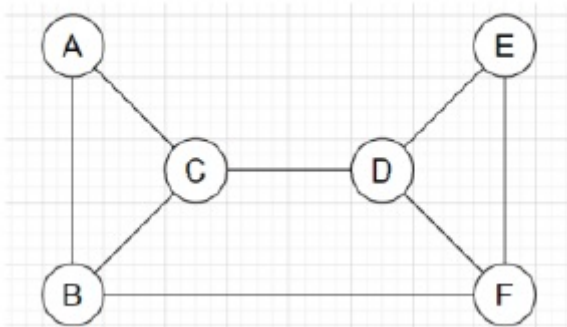

Options :

1. ✔ {D, B}

2. ✘ {C, A}

3. ✘ {A, E}

4. ✘ {C, D}

Question Number : 103 Question Id : 3330085503 Display Question Number : Yes Is Question Mandatory : No Calculator : None Response Time : N.A Think Time : N.A Minimum Instruction Time : 0

Register A holds the 8-bit binary 11011001, to change the value of Register A to 01101101, the following logic microoperation has to be performed on the operand respectively.

Options :

1. ✓ 10110100, XOR
2. ✗ 10110100, OR
3. ✗ 10110100, AND
4. ✗ 11111111, XNOR

Question Number : 104 Question Id : 3330085504 Display Question Number : Yes Is Question Mandatory : No Calculator : None Response Time : N.A Think Time : N.A Minimum Instruction Time : 0

The number of clock cycles that it takes to process 200 tasks in a six-segment pipeline is

Options :

1. ✓ 205
2. ✗ 1200
3. ✗ 206

4. ✘ 1000

Question Number : 105 Question Id : 3330085505 Display Question Number : Yes Is Question Mandatory : No Calculator : None Response Time : N.A Think Time : N.A Minimum Instruction Time : 0

Which of the following is related to DBMS?

Options :

1. ✘ Public key

2. ✘ Private key

3. ✘ Symmetric key

4. ✔ Candidate key

Question Number : 106 Question Id : 3330085506 Display Question Number : Yes Is Question Mandatory : No Calculator : None Response Time : N.A Think Time : N.A Minimum Instruction Time : 0

The set $S = \{1, 2, 3, 4, 5, 6, 7, 8, 9, 10, 11, 12\}$ is to be portioned into three sets A, B, C of equal size. Thus $A \cup B \cup C = S$, $A \cap B = B \cap C = A \cap C = \emptyset$. The number of ways to partition S is

Options :

1. ✔ $\frac{12!}{(4!)^3}$

2. ✘ $\frac{12!}{3!(4!)^3}$

3. ✘ $\frac{12!}{(4!)^4}$

4. ✘ $\frac{12!}{3!(4!)^4}$

Question Number : 107 Question Id : 3330085507 Display Question Number : Yes Is Question Mandatory : No Calculator : None Response Time : N.A Think Time : N.A Minimum Instruction Time : 0

The union and intersection of the Graphs G and H are respectively

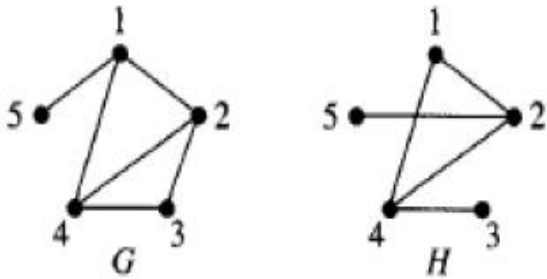

Options :

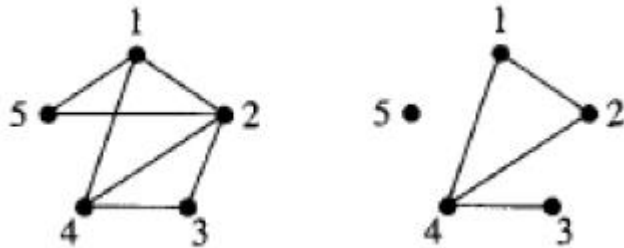

1. ✔

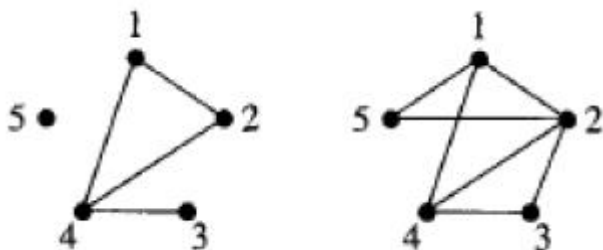

2. ✘

3. ✖

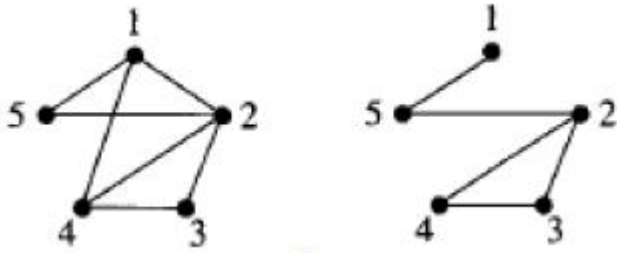

4. ✖

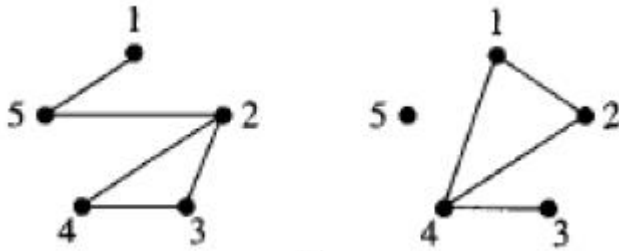

Question Number : 108 Question Id : 3330085508 Display Question Number : Yes Is Question Mandatory : No Calculator : None Response Time : N.A Think Time : N.A Minimum Instruction Time : 0

Match the following:

GROUP-I	GROUP-II
a. Lexical Analysis	i. Shift-reduce
b. Syntax Analysis	ii. Scanner
c. Generate code for multiple machines	iii. Parser
d. Bottom-up parsing	iv. Cross Compiler

Options :

1. ✓ a. – ii, b. – iii, c. – iv, d. – i.

2. ✖ a. – ii, b. – i, c. – iv, d. – iii.

3. ✘ a. – ii, b. – iv, c. – iii, d. – i.

4. ✘ a. – ii, b. – iii, c. – i, d. – iv.

Question Number : 109 Question Id : 3330085509 Display Question Number : Yes Is Question Mandatory : No Calculator : None Response Time : N.A Think Time : N.A Minimum Instruction Time : 0

Let A and B be two independent events, then $P(A \cap B') =$

Options :

1. ✔ $P(A).P(B')$

2. ✘ $P(A).P(B)$

3. ✘ $P(A) - P(A \cup B)$

4. ✘ $P(B).P(A')$

Question Number : 110 Question Id : 3330085510 Display Question Number : Yes Is Question Mandatory : No Calculator : None Response Time : N.A Think Time : N.A Minimum Instruction Time : 0

A pair of dice is thrown. The probability that the sum is neither 7 or 8 is

Options :

1. ✘ $\frac{11}{36}$

2. ✘ $\frac{15}{36}$

3. ✘ $\frac{17}{36}$

4. ✔ $\frac{25}{36}$

Question Number : 111 Question Id : 3330085511 Display Question Number : Yes Is Question Mandatory : No Calculator : None Response Time : N.A Think Time : N.A Minimum Instruction Time : 0

Let X be a continuous random variable denoting the temperature measured. The range of temperature is $[0, 100]$ degree Celsius and let the probability density function of X be $f(X) = 0.01$ for $0 \leq X \leq 100$. The mean is

Options :

1. ✘ 5.0

2. ✘ 2.5

3. ✘ 25.0

4. ✔ 50.0

Question Number : 112 Question Id : 3330085512 Display Question Number : Yes Is Question Mandatory : No Calculator : None Response Time : N.A Think Time : N.A Minimum Instruction

Time : 0

If the Boolean expression $(p \Rightarrow q) \Leftrightarrow (q * (\sim p))$ is a tautology, then the Boolean expression $(p * (\sim q))$ is equivalent to

Options :

1. ✘ $p \Rightarrow q$

2. ✔ $q \Rightarrow p$

3. ✘ $p \Rightarrow \sim q$

4. ✘ $\sim q \Rightarrow p$

Question Number : 113 Question Id : 3330085513 Display Question Number : Yes Is Question Mandatory : No Calculator : None Response Time : N.A Think Time : N.A Minimum Instruction Time : 0

For the function $f(x) = x^2 e^{-x}$, the maximum occurs when x is equal to

Options :

1. ✔ 2

2. ✘ 1

3. ✘ -1

4. ✘ 0

Question Number : 114 Question Id : 3330085514 Display Question Number : Yes Is Question Mandatory : No Calculator : None Response Time : N.A Think Time : N.A Minimum Instruction Time : 0

Two of the eigenvalues of 3×3 matrix are -1 and 2, the determinant of the matrix is 4 then the third eigenvalue is _____

Options :

1. ✘ -1

2. ✔ -2

3. ✘ 2

4. ✘ 1

Question Number : 115 Question Id : 3330085515 Display Question Number : Yes Is Question Mandatory : No Calculator : None Response Time : N.A Think Time : N.A Minimum Instruction Time : 0

For which value of x , the matrix A has no inverse where $A = \begin{bmatrix} 8 & x & 0 \\ 4 & 0 & 2 \\ 12 & 6 & 0 \end{bmatrix}$

Options :

1. ✘

6

2. ✓ 4

3. ✗ 12

4. ✗ 8

Question Number : 116 Question Id : 3330085516 Display Question Number : Yes Is Question Mandatory : No Calculator : None Response Time : N.A Think Time : N.A Minimum Instruction Time : 0

The Newton-Raphson method fails for the function $f(x)$, if -----

Options :

1. ✓ $f'(x)$ is negative

2. ✗ $f'(x)$ is too large

3. ✗ $f'(x)$ is zero

4. ✗ Never fails

Question Number : 117 Question Id : 3330085517 Display Question Number : Yes Is Question

Mandatory : No Calculator : None Response Time : N.A Think Time : N.A Minimum Instruction

Time : 0

The quadratic equation $2x^2 - 3x + 3 = 0$ is to be solved numerically starting with initial guess as $x_0 = 2$. The new estimate of x after first iteration using Newton-Raphson method is _____

Options :

1. ✓ 1

2. ✗ 2

3. ✗ 1/152

4. ✗ 1.7

Question Number : 118 Question Id : 3330085518 Display Question Number : Yes Is Question

Mandatory : No Calculator : None Response Time : N.A Think Time : N.A Minimum Instruction

Time : 0

If $A = \begin{bmatrix} -5 & -8 & 0 \\ 3 & 5 & 0 \\ 1 & 2 & -1 \end{bmatrix}$ then A^2 is

Options :

1. ✗ Idempotent

2. ✗ Nilpotent

3. ✗ Symmetric

4. ✓ Involutory

Question Number : 119 Question Id : 3330085519 Display Question Number : Yes Is Question Mandatory : No Calculator : None Response Time : N.A Think Time : N.A Minimum Instruction Time : 0

The following improper integral $\int_1^{\infty} \frac{dx}{x^p}$ converge for which value of p

Options :

1. ✓ $p > 1$

2. ✗ $p < 2$

3. ✗ $p \geq 0$

4. ✗ $p = 0$

Question Number : 120 Question Id : 3330085520 Display Question Number : Yes Is Question Mandatory : No Calculator : None Response Time : N.A Think Time : N.A Minimum Instruction Time : 0

The value of $\lim_{x \rightarrow 0} (1 + 2x)^{1/x}$ is

Options :

1. ✗ 0

2. ✓ e^2

3. ✗ e^{-2}

4. ✗ e