

Andhra Pradesh State Council of Higher Education

Notations :

- 1.Options shown in green color and with ✓ icon are correct.
- 2.Options shown in red color and with ✗ icon are incorrect.

Question Paper Name :	Instrumentation Engineering 31st May 2024 Shift 1
Duration :	120
Total Marks :	120
Display Marks:	No
Share Answer Key With Delivery Engine :	Yes
Calculator :	None
Magnifying Glass Required? :	No
Ruler Required? :	No
Eraser Required? :	No
Scratch Pad Required? :	No
Rough Sketch/Notepad Required? :	No
Protractor Required? :	No
Show Watermark on Console? :	Yes
Highlighter :	No
Auto Save on Console?	Yes
Change Font Color :	No
Change Background Color :	No
Change Theme :	No
Help Button :	No
Show Reports :	No

Show Progress Bar :	No
Is this Group for Examiner? :	No
Examiner permission :	Cant View
Show Progress Bar? :	No

Instrumentation Engineering

Section Id :	33300854
Section Number :	1
Mandatory or Optional :	Mandatory
Number of Questions :	120
Section Marks :	120
Enable Mark as Answered Mark for Review and Clear Response :	Yes
Maximum Instruction Time :	0
Is Section Default? :	null

Question Number : 1 Question Id : 3330086361 Display Question Number : Yes Is Question Mandatory : No Calculator : None Response Time : N.A Think Time : N.A Minimum Instruction Time : 0

The algebraic sum of voltages around any closed path in a network is equal to _____.

Options :

1. ✘ Infinity

2. ✘ 1

3. ✔ 0

4.

✖ Negative polarity

Question Number : 2 Question Id : 3330086362 Display Question Number : Yes Is Question Mandatory : No Calculator : None Response Time : N.A Think Time : N.A Minimum Instruction Time : 0

Calculate the mesh currents I_1 and I_2 flowing in the first and second meshes respectively.

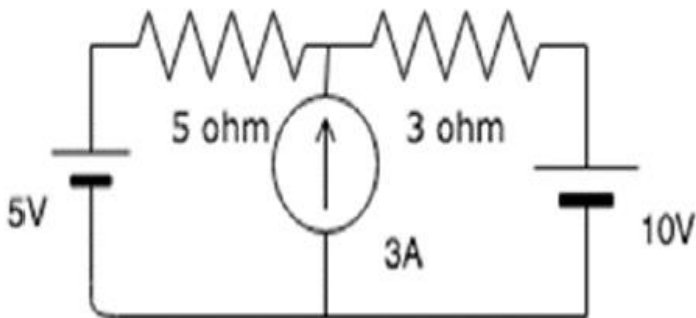

Options :

1. ✔ 1.75A, 1.25A

2. ✖ 0.5A, 2.5A

3. ✖ 2.3A, 0.3A

4. ✖ 3.2A, 6.5A

Question Number : 3 Question Id : 3330086363 Display Question Number : Yes Is Question Mandatory : No Calculator : None Response Time : N.A Think Time : N.A Minimum Instruction Time : 0

Find the value of V_{th} for circuit shown below

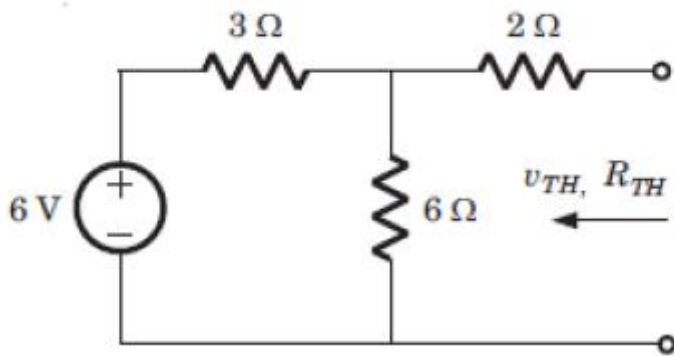

Options :

1. ✘ 1 V
2. ✘ 2 V
3. ✘ 3 V
4. ✔ 4 V

Question Number : 4 Question Id : 3330086364 Display Question Number : Yes Is Question Mandatory : No Calculator : None Response Time : N.A Think Time : N.A Minimum Instruction Time : 0

Which method can reduce dynamic error?

Options :

1. ✘ By increasing accuracy
2. ✘ By increasing precession

3. ✘ By reducing sensitivity

4. ✔ By reducing time lag

Question Number : 5 Question Id : 3330086365 Display Question Number : Yes Is Question Mandatory : No Calculator : None Response Time : N.A Think Time : N.A Minimum Instruction Time : 0

What is the relative error percentage of an observation taken by an ultrasonic sensor which predicts the distance of an object to be 2.12 cm but the actual value is 2 cm?

Options :

1. ✘ 12%

2. ✘ 10%

3. ✔ 6%

4. ✘ 1%

Question Number : 6 Question Id : 3330086366 Display Question Number : Yes Is Question Mandatory : No Calculator : None Response Time : N.A Think Time : N.A Minimum Instruction Time : 0

Which among the following is not a dynamic characteristic?

Options :

1. ✓ Precession
2. ✘ Measuring lag
3. ✘ Dynamic error
4. ✘ Fidelity

Question Number : 7 Question Id : 3330086367 Display Question Number : Yes Is Question Mandatory : No Calculator : None Response Time : N.A Think Time : N.A Minimum Instruction Time : 0

Which of the following error is not a systematic error?

Options :

1. ✘ Error induced due to stylus pressure
2. ✘ Instrument location errors
3. ✘ Error due to parallax
4. ✓ Error due to play in the instrument's linkages

Question Number : 8 Question Id : 3330086368 Display Question Number : Yes Is Question Mandatory : No Calculator : None Response Time : N.A Think Time : N.A Minimum

Time : 0

The ratio of the current transform at one port to current transform at other port is called _____.

Options :

1. ✘ Transfer admittance
2. ✘ Transfer impedance
3. ✔ Current transfer ratio
4. ✘ Voltage transfer ratio

Question Number : 9 Question Id : 3330086369 Display Question Number : Yes Is Question Mandatory : No Calculator : None Response Time : N.A Think Time : N.A Minimum Instruction Time : 0

If there are 10 nodes in a circuit, how many equations do we get?

Options :

1. ✘ 0
2. ✔ 9
3. ✘ 8
4. ✘ 7

Question Number : 10 Question Id : 3330086370 Display Question Number : Yes Is Question Mandatory : No Calculator : None Response Time : N.A Think Time : N.A Minimum Instruction Time : 0

Thermocouple system has a time constant of 8 sec. It is used to measure temperature of a surface varying sinusoidally between 400°C and 450°C with a periodic time of 60 sec. The thermocouple will indicate the maximum temperature of

Options :

1. ✘ 450.0°C

2. ✔ 444.2°C

3. ✘ 425.0°C

4. ✘ 405.0°C

Question Number : 11 Question Id : 3330086371 Display Question Number : Yes Is Question Mandatory : No Calculator : None Response Time : N.A Think Time : N.A Minimum Instruction Time : 0

Output of a bimetallic element will be

Options :

1. ✘ Strain

2.

✘ Pressure

3. ✔ Displacement

4. ✘ Voltage

Question Number : 12 Question Id : 3330086372 Display Question Number : Yes Is Question Mandatory : No Calculator : None Response Time : N.A Think Time : N.A Minimum Instruction Time : 0

The flow meter which has highest discharge coefficient is _____.

Options :

1. ✘ Orifice

2. ✔ Venturi meter

3. ✘ Pivot tube

4. ✘ Rotameter

Question Number : 13 Question Id : 3330086373 Display Question Number : Yes Is Question Mandatory : No Calculator : None Response Time : N.A Think Time : N.A Minimum Instruction Time : 0

An A.C signal conditioning system is normally used for

Options :

1. ✘ Resistive transducer like strain gauges
2. ✔ Inductive and capacitive transducer
3. ✘ Piezoelectric transducer
4. ✘ Voltage transducer

Question Number : 14 Question Id : 3330086374 Display Question Number : Yes Is Question Mandatory : No Calculator : None Response Time : N.A Think Time : N.A Minimum Instruction Time : 0

_____measures dynamic pressure.

Options :

1. ✘ Bourdon tube pressure gauges
2. ✘ Barometric sensor
3. ✔ Piezoelectric pressure sensor
4. ✘

Piezoresistive pressure sensor

Question Number : 15 Question Id : 3330086375 Display Question Number : Yes Is Question Mandatory : No Calculator : None Response Time : N.A Think Time : N.A Minimum Instruction Time : 0

Which of the following techniques is suitable to measure a leakage resistance of a capacitor?

Options :

1. ✘ Loss of charge bridge
2. ✘ Kelvins double bridge
3. ✔ Ammeter voltmeter method
4. ✘ Wheatstone bridge

Question Number : 16 Question Id : 3330086376 Display Question Number : Yes Is Question Mandatory : No Calculator : None Response Time : N.A Think Time : N.A Minimum Instruction Time : 0

pH of a pure water is _____.

Options :

1. ✘ 5

2. ✘ 6

3. ✔ 7

4. ✘ 8

Question Number : 17 Question Id : 3330086377 Display Question Number : Yes Is Question Mandatory : No Calculator : None Response Time : N.A Think Time : N.A Minimum Instruction Time : 0

The SI unit of conductivity is

Options :

1. ✘ Meter

2. ✘ Ohm-meter

3. ✘ Ohm

4. ✔ Siemens per meter (S/m)

Question Number : 18 Question Id : 3330086378 Display Question Number : Yes Is Question Mandatory : No Calculator : None Response Time : N.A Think Time : N.A Minimum Instruction Time : 0

Which type of rays are commonly used in radiation level detector?

Options :

1. ✓ Gamma rays

2. ✗ Beta rays

3. ✗ Nuclear radiation

4. ✗ Alpha rays

Question Number : 19 Question Id : 3330086379 Display Question Number : Yes Is Question Mandatory : No Calculator : None Response Time : N.A Think Time : N.A Minimum Instruction Time : 0

_____ is the term connected with the amount of water vapour present in air or gas.

Options :

1. ✗ Moisture

2. ✓ Humidity

3. ✗ Viscosity

4. ✗ Density

Question Number : 20 Question Id : 3330086380 Display Question Number : Yes Is Question Mandatory : No Calculator : None Response Time : N.A Think Time : N.A Minimum Instruction Time : 0

Pitot tube is used mainly for _____ measurement.

Options :

1. ✘ Level
2. ✘ Viscosity
3. ✔ Fluid velocity
4. ✘ Humidity

Question Number : 21 Question Id : 3330086381 Display Question Number : Yes Is Question Mandatory : No Calculator : None Response Time : N.A Think Time : N.A Minimum Instruction Time : 0

_____ effect defines the creation of electromotive force in thermocouple transducer?

Options :

1. ✔ Seebeck effect
2. ✘ Hall effect

3. ✘ Demagnetization

4. ✘ Magnetization

Question Number : 22 Question Id : 3330086382 Display Question Number : Yes Is Question Mandatory : No Calculator : None Response Time : N.A Think Time : N.A Minimum Instruction Time : 0

Resistance of an ideal diode during reverse biasing is

Options :

1. ✘ Zero

2. ✘ Unity

3. ✘ Finite

4. ✔ Infinite

Question Number : 23 Question Id : 3330086383 Display Question Number : Yes Is Question Mandatory : No Calculator : None Response Time : N.A Think Time : N.A Minimum Instruction Time : 0

The point of intersection which is called the Q point, represents

Options :

1. ✘

The intersection of cutoff and diode current

2. ✘ The intersection of cutoff and the diode voltage

3. ✘ The intersection of saturation and diode current

4. ✔ The intersection of the diode curve and the load line

Question Number : 24 Question Id : 3330086384 Display Question Number : Yes Is Question Mandatory : No Calculator : None Response Time : N.A Think Time : N.A Minimum Instruction Time : 0

What is the maximum collector efficiency of a transformer coupled Class A power amplifier?

Options :

1. ✘ 30%

2. ✘ 80%

3. ✘ 45%

4. ✔ 50%

Question Number : 25 Question Id : 3330086385 Display Question Number : Yes Is Question Mandatory : No Calculator : None Response Time : N.A Think Time : N.A Minimum Instruction Time : 0

In a BJT, largest current flow occurs

Options :

1. ✓ In the emitter
2. ✗ In the collector
3. ✗ In the base
4. ✗ Through CB junction.

Question Number : 26 Question Id : 3330086386 Display Question Number : Yes Is Question Mandatory : No Calculator : None Response Time : N.A Think Time : N.A Minimum Instruction Time : 0

With the Enhancement MOSFET, when gate input voltage is zero, drain current is

Options :

1. ✗ At saturation
2. ✓ Zero
3. ✗ I_{DSS}

4. ✘ Widening the channel

Question Number : 27 Question Id : 3330086387 Display Question Number : Yes Is Question Mandatory : No Calculator : None Response Time : N.A Think Time : N.A Minimum Instruction Time : 0

When an input signal reduces the channel size, the process is called

Options :

1. ✘ Enhancement

2. ✘ Substrate connecting

3. ✘ Gate charge

4. ✔ Depletion

Question Number : 28 Question Id : 3330086388 Display Question Number : Yes Is Question Mandatory : No Calculator : None Response Time : N.A Think Time : N.A Minimum Instruction Time : 0

A circuit that removes all the positive parts of the input signal is a

Options :

1. ✔ Positive clipper

2. ✘ Positive clamper

3. ✘ Negative clipper

4. ✘ Positive voltage doubler

Question Number : 29 Question Id : 3330086389 Display Question Number : Yes Is Question Mandatory : No Calculator : None Response Time : N.A Think Time : N.A Minimum Instruction Time : 0

In an ideal op-amp, which is not true?

Options :

1. ✘ Open loop voltage gain is infinite

2. ✘ Input resistance is infinite

3. ✘ Slew rate is infinite

4. ✔ CMRR is zero

Question Number : 30 Question Id : 3330086390 Display Question Number : Yes Is Question Mandatory : No Calculator : None Response Time : N.A Think Time : N.A Minimum Instruction

Time : 0

What is the use of the compensation capacitor in op-amp?

Options :

1. ✘ Improves the amplification of op-amp
2. ✔ Decreases the slew rate of op-amp
3. ✘ Increases the bandwidth of op-amp
4. ✘ Op-amp acts as all pass filter

Question Number : 31 Question Id : 3330086391 Display Question Number : Yes Is Question Mandatory : No Calculator : None Response Time : N.A Think Time : N.A Minimum Instruction

Time : 0

What instrument is used to amplify output signal of transducer

Options :

1. ✘ Peaking amplifier
2. ✔ Instrumentation amplifier
3. ✘ Differential amplifier

4. ✘ Bridge amplifier

Question Number : 32 Question Id : 3330086392 Display Question Number : Yes Is Question Mandatory : No Calculator : None Response Time : N.A Think Time : N.A Minimum Instruction Time : 0

_____ and Current series are series type feedback connections.

Options :

1. ✔ Voltage series feedback

2. ✘ Current series feedback

3. ✘ Voltage shunt feedback

4. ✘ Current shunt feedback

Question Number : 33 Question Id : 3330086393 Display Question Number : Yes Is Question Mandatory : No Calculator : None Response Time : N.A Think Time : N.A Minimum Instruction Time : 0

The value of feedback resistor and resistor connected in series with the input signal source are equal to $10\text{k}\Omega$ and $3.3\text{k}\Omega$. Calculate the closed loop voltage gain?

Options :

1. ✘ -6.7

2. ✘ -33

3. ✘ -13.3

4. ✔ -3.33

Question Number : 34 Question Id : 3330086394 Display Question Number : Yes Is Question Mandatory : No Calculator : None Response Time : N.A Think Time : N.A Minimum Instruction Time : 0

The current to voltage converter photosensitive device can be used as

Options :

1. ✔ Light intensity meter

2. ✘ Light radiating meter

3. ✘ Light deposition meter

4. ✘ Light absorption meter

Question Number : 35 Question Id : 3330086395 Display Question Number : Yes Is Question Mandatory : No Calculator : None Response Time : N.A Think Time : N.A Minimum Instruction Time : 0

Which of the oscillators doesn't come under the category of low frequency oscillators?

Options :

1. ✘ RC phase shift oscillator
2. ✘ Wien bridge oscillator
3. ✘ Twin T oscillators
4. ✔ Crystal oscillator

Question Number : 36 Question Id : 3330086396 Display Question Number : Yes Is Question Mandatory : No Calculator : None Response Time : N.A Think Time : N.A Minimum Instruction Time : 0

In RC phase shift oscillator, one R-C bridge provides _____ phase shift

Options :

1. ✘ 30°
2. ✔ 60°
3. ✘ 90°
4. ✘ 180°

Question Number : 37 Question Id : 3330086397 Display Question Number : Yes Is Question Mandatory : No Calculator : None Response Time : N.A Think Time : N.A Minimum Instruction Time : 0

Which of the following logic expressions represents the logic diagram shown?

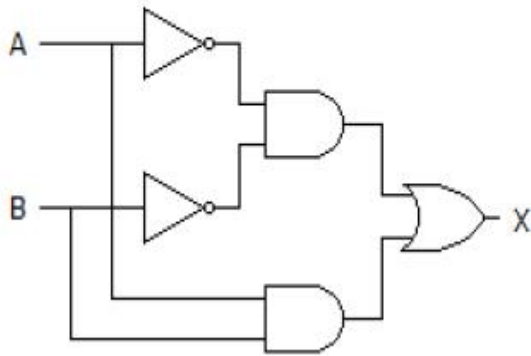

Options :

1. ✘ $X=AB'+A'B$

2. ✘ $X=(AB)'+AB$

3. ✘ $X=(AB)'+A'B'$

4. ✔ $X=A'B'+AB$

Question Number : 38 Question Id : 3330086398 Display Question Number : Yes Is Question Mandatory : No Calculator : None Response Time : N.A Think Time : N.A Minimum Instruction Time : 0

Find the simplified expression $A'BC'+AC'$.

Options :

1. ✘ B

2. ✘ $A+C$

3. ✔ $(A+B)C'$

4. ✘ $B'C$

Question Number : 39 Question Id : 3330086399 Display Question Number : Yes Is Question Mandatory : No Calculator : None Response Time : N.A Think Time : N.A Minimum Instruction Time : 0

Which gate is called the anticoincidence and coincidence gate respectively?

Options :

1. ✘ XNOR and XOR

2. ✘ AND and OR

3. ✘ OR and AND

4. ✔ XOR and XNOR

Question Number : 40 Question Id : 3330086400 Display Question Number : Yes Is Question

Mandatory : No Calculator : None Response Time : N.A Think Time : N.A Minimum Instruction Time : 0

The parity check detection is done using

Options :

1. ✘ OR gate
2. ✘ AND gate
3. ✔ XOR gate
4. ✘ NOR gate

Question Number : 41 Question Id : 3330086401 Display Question Number : Yes Is Question Mandatory : No Calculator : None Response Time : N.A Think Time : N.A Minimum Instruction Time : 0

The code where all successive numbers differ from their preceding number by a single bit is _____

Options :

1. ✘ Alphanumeric Code
2. ✘ BCD
3. ✘ Excess 3

4. ✓ Gray

Question Number : 42 Question Id : 3330086402 Display Question Number : Yes Is Question Mandatory : No Calculator : None Response Time : N.A Think Time : N.A Minimum Instruction Time : 0

How many inputs are required for a digital comparator?

Options :

1. ✗ 1

2. ✓ 2

3. ✗ 3

4. ✗ 4

Question Number : 43 Question Id : 3330086403 Display Question Number : Yes Is Question Mandatory : No Calculator : None Response Time : N.A Think Time : N.A Minimum Instruction Time : 0

How many 3-line-to-8-line decoders are required for a 1-of-32 decoder?

Options :

1. ✓ 4

2. ✗ 2

3. ✘ 1

4. ✘ 8

Question Number : 44 Question Id : 3330086404 Display Question Number : Yes Is Question Mandatory : No Calculator : None Response Time : N.A Think Time : N.A Minimum Instruction Time : 0

A basic S-R flip-flop can be constructed by cross-coupling of which basic logic gates?

Options :

1. ✘ AND or OR gates

2. ✘ XOR or XNOR gates

3. ✔ NOR or NAND gates

4. ✘ AND or NOR gates

Question Number : 45 Question Id : 3330086405 Display Question Number : Yes Is Question Mandatory : No Calculator : None Response Time : N.A Think Time : N.A Minimum Instruction Time : 0

How many equal intervals are present in a 14-bit D-A converter?

Options :

1. ✓ 16383

2. ✗ 4095

3. ✗ 65535

4. ✗ 1023

Question Number : 46 Question Id : 3330086406 Display Question Number : Yes Is Question Mandatory : No Calculator : None Response Time : N.A Think Time : N.A Minimum Instruction Time : 0

The representation of octal number $(532.2)_8$ in decimal is _____

Options :

1. ✓ $(346.25)_{10}$

2. ✗ $(532.864)_{10}$

3. ✗ $(340.67)_{10}$

4. ✗ $(531.668)_{10}$

Question Number : 47 Question Id : 3330086407 Display Question Number : Yes Is Question Mandatory : No Calculator : None Response Time : N.A Think Time : N.A Minimum Instruction Time : 0

Which of the following is the correct sequence of operations in a microprocessor?

Options :

1. ✓ Opcode fetch, memory read, memory write, I/O read, I/O write
2. ✗ Opcode fetch, memory write, memory read, I/O read, I/O write
3. ✗ I/O read, opcode fetch, memory read, memory write, I/O write
4. ✗ I/O read, opcode fetch, memory write, memory read, I/O write

Question Number : 48 Question Id : 3330086408 Display Question Number : Yes Is Question Mandatory : No Calculator : None Response Time : N.A Think Time : N.A Minimum Instruction Time : 0

Which of the following file extension that is loaded in a microcontroller for executing any instruction?

Options :

1. ✗ .c
2. ✗ .txt

3. ✓ .hex

4. ✘ .doc

Question Number : 49 Question Id : 3330086409 Display Question Number : Yes Is Question Mandatory : No Calculator : None Response Time : N.A Think Time : N.A Minimum Instruction Time : 0

What will happen in that condition, if an interrupt occurs while the microcontroller is serving any other interrupt?

Options :

1. ✓ The interrupt that is more priority in the interrupt vector table will be served first

2. ✘ Both the interrupts will be handled simultaneously

3. ✘ The interrupt having low priority in the interrupt vector table will be served first

4. ✘ The interrupt which is being done first will be served first

Question Number : 50 Question Id : 3330086410 Display Question Number : Yes Is Question Mandatory : No Calculator : None Response Time : N.A Think Time : N.A Minimum Instruction Time : 0

Choosing a discrete value that is near but not exactly at the analog signal level leads to

Options :

1. ✘ PCM error
2. ✔ Quantization error
3. ✘ PAM error
4. ✘ Sampling error

Question Number : 51 Question Id : 3330086411 Display Question Number : Yes Is Question Mandatory : No Calculator : None Response Time : N.A Think Time : N.A Minimum Instruction Time : 0

In PCM the samples are dependent on _____

Options :

1. ✔ Time
2. ✘ Frequency
3. ✘ Quantization level
4. ✘ Interval between quantization level

Question Number : 52 Question Id : 3330086412 Display Question Number : Yes Is Question Mandatory : No Calculator : None Response Time : N.A Think Time : N.A Minimum Instruction Time : 0

Why is AM used for broadcasting in the communication systems?

Options :

1. ✓ Its use avoids receiver complexity
2. ✘ It is more immune to other modulation systems
3. ✘ It requires less transmitting power
4. ✘ No noise disturbances

Question Number : 53 Question Id : 3330086413 Display Question Number : Yes Is Question Mandatory : No Calculator : None Response Time : N.A Think Time : N.A Minimum Instruction Time : 0

One TDM frame consists of one time slot per _____?

Options :

1. ✘ Frequency slots
2. ✘ Time slot

3. ✓ Sub channels

4. ✘ Frames

Question Number : 54 Question Id : 3330086414 Display Question Number : Yes Is Question Mandatory : No Calculator : None Response Time : N.A Think Time : N.A Minimum Instruction Time : 0

The amount of frequency deviation in FM signal depends on

Options :

1. ✓ Amplitude of the modulating signal

2. ✘ Carrier frequency

3. ✘ Modulating frequency

4. ✘ Transmitter amplifier

Question Number : 55 Question Id : 3330086415 Display Question Number : Yes Is Question Mandatory : No Calculator : None Response Time : N.A Think Time : N.A Minimum Instruction Time : 0

What gets shifted in the signals involved in Frequency Shift Keying?

Options :

1. ✘ Amplitude
2. ✔ Frequency
3. ✘ Phase
4. ✘ Amplitude and Phase

Question Number : 56 Question Id : 3330086416 Display Question Number : Yes Is Question Mandatory : No Calculator : None Response Time : N.A Think Time : N.A Minimum Instruction Time : 0

In which of the following digital modulation carrier wave switches between 0 and 1 based on applied input?

Options :

1. ✔ Amplitude Shift Keying
2. ✘ Phase Shift Keying
3. ✘ Frequency Shift Keying
4. ✘ Phase Shift Keying and Frequency Shift Keying

Question Number : 57 Question Id : 3330086417 Display Question Number : Yes Is Question Mandatory : No Calculator : None Response Time : N.A Think Time : N.A Minimum Instruction Time : 0

In a PCM system, if the code word length is increased from 6 to 8 bits, the signal to quantization noise ratio improves by the factor

Options :

1. ✘ 6

2. ✘ 8

3. ✘ 12

4. ✔ 16

Question Number : 58 Question Id : 3330086418 Display Question Number : Yes Is Question Mandatory : No Calculator : None Response Time : N.A Think Time : N.A Minimum Instruction Time : 0

Given the signal,
 $X(t) = \cos t, \text{ if } t < 0$
 $\sin t, \text{ if } t \geq 0$

The correct statement among the following is?

Options :

Periodic with fundamental period 2π

1. ✘

2. ✘ Periodic but with no fundamental period

3. ✔ Non-periodic and discontinuous

4. ✘ Non-periodic but continuous

Question Number : 59 Question Id : 3330086419 Display Question Number : Yes Is Question Mandatory : No Calculator : None Response Time : N.A Think Time : N.A Minimum Instruction Time : 0

How is the discrete time impulse function defined in terms of the step function?

Options :

1. ✘ $\delta[n] = u[n+1] - u[n].$

2. ✘ $\delta[n] = u[n] - u[n-2].$

3. ✔ $\delta[n] = u[n] - u[n-1].$

4. ✘ $\delta[n] = u[n+1] - u[n-1].$

Question Number : 60 Question Id : 3330086420 Display Question Number : Yes Is Question Mandatory : No Calculator : None Response Time : N.A Think Time : N.A Minimum Instruction Time : 0

How is the continuous time impulse function defined in terms of the step function?

Options :

1. ✘ $u(t) = \frac{d}{dt} \delta(t)$

2. ✘ $u(t) = \delta(t)$

3. ✔ $\delta(t) = \frac{d}{dt} u(t)$

4. ✘ $\delta(t) = u(2t)$

Question Number : 61 Question Id : 3330086421 Display Question Number : Yes Is Question Mandatory : No Calculator : None Response Time : N.A Think Time : N.A Minimum Instruction Time : 0

A linear system at rest is subject to an input signal $r(t) = 1 - e^{-t}$. The response of the system for $t > 0$ is given by $c(t) = 1 - e^{-2t}$. The transfer function of the system is:

Options :

1. ✘ $(s+2)/(s+1)$

2. ✔ $2(s+1)/(s+2)$

3. ✘ $(s+1)/(s+2)$

$$(s+1)/2(s+2)$$

4. ✘

Question Number : 62 Question Id : 3330086422 Display Question Number : Yes Is Question Mandatory : No Calculator : None Response Time : N.A Think Time : N.A Minimum Instruction Time : 0

The type of noise that would interfere much with the high frequency transmission is

Options :

Shot

1. ✘

Transit time

2. ✔

Flicker

3. ✘

White

4. ✘

Question Number : 63 Question Id : 3330086423 Display Question Number : Yes Is Question Mandatory : No Calculator : None Response Time : N.A Think Time : N.A Minimum Instruction Time : 0

Wagner's earth devices are used in a.c. bridge circuits for

Options :

Eliminating the effects of earth capacitance

1. ✔

2. ✘ Eliminating the effects of inter component capacitance
3. ✘ Eliminating the effects of stray electrostatic fields
4. ✘ Shielding the bridge elements

Question Number : 64 Question Id : 3330086424 Display Question Number : Yes Is Question Mandatory : No Calculator : None Response Time : N.A Think Time : N.A Minimum Instruction Time : 0

Capacitance can be measured using

Options :

1. ✘ Maxwell's bridge
2. ✔ Schering's bridge
3. ✘ Campbell bridge
4. ✘ Wien's bridge

Question Number : 65 Question Id : 3330086425 Display Question Number : Yes Is Question Mandatory : No Calculator : None Response Time : N.A Think Time : N.A Minimum Instruction Time : 0

The phase displacement of the rotor emf in Drysdale potentiometer being equal to

Options :

1. ✓ Angle of rotor from zero position
2. ✗ Angle of rotor
3. ✗ Angle of the slide wire
4. ✗ Angle of rotor with reference to stator coil

Question Number : 66 Question Id : 3330086426 Display Question Number : Yes Is Question Mandatory : No Calculator : None Response Time : N.A Think Time : N.A Minimum Instruction Time : 0

A PMMC instrument can be used as ammeter and as voltmeter with the help of

Options :

1. ✗ A low resistance shunt, a low series resistance
2. ✓ A low resistance shunt, a high series resistance
3. ✗ A high series resistance, a low resistance shunt
4. ✗

A low series resistance, a high shunt resistance

Question Number : 67 Question Id : 3330086427 Display Question Number : Yes Is Question Mandatory : No Calculator : None Response Time : N.A Think Time : N.A Minimum Instruction Time : 0

A 4-range milliammeter having ranges of 0-10mA, 0-50 mA, 0-100 mA, 0-500 mA. It is used for measurement of current whose magnitude is not known. In order to prevent damage to the instrument, the selector switch of the ammeter should be first placed at

Options :

1. ✘ 0-10 mA
2. ✘ 0-50 mA range
3. ✘ 0-100 mA range
4. ✔ 0-500 mA range

Question Number : 68 Question Id : 3330086428 Display Question Number : Yes Is Question Mandatory : No Calculator : None Response Time : N.A Think Time : N.A Minimum Instruction Time : 0

In the given circuit below, voltage $V_C(t)$ is

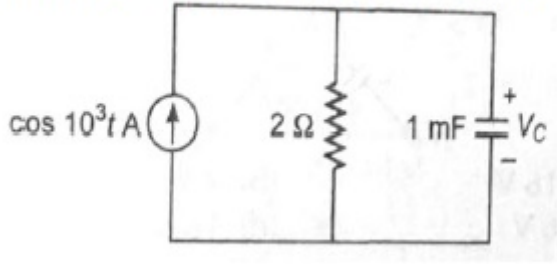

Options :

1. ✓ $0.89 \cos (10^3 t - 63.43^\circ) \text{ V}$
2. ✗ $0.89 \cos (10^3 t + 63.43^\circ) \text{ V}$
3. ✗ $0.45 \cos (10^3 t + 26.57^\circ) \text{ V}$
4. ✗ $0.45 \cos (10^3 t - 26.57^\circ) \text{ V}$

Question Number : 69 Question Id : 3330086429 Display Question Number : Yes Is Question Mandatory : No Calculator : None Response Time : N.A Think Time : N.A Minimum Instruction Time : 0

Which of the following represents the correct relationship between frequency and angular frequency?

Options :

1. ✓ $\omega = 2\pi f$
2. ✗ $\omega = \pi f$

$$f=2\pi\omega$$

3. ✘

$$f=\pi\omega$$

4. ✘

Question Number : 70 Question Id : 3330086430 Display Question Number : Yes Is Question Mandatory : No Calculator : None Response Time : N.A Think Time : N.A Minimum Instruction Time : 0

Phase difference between two voltages at frequencies above 10Hz can be measured using _____

Options :

CRO

1. ✔

Voltmeter

2. ✘

X-Y plotter

3. ✘

Multi meter

4. ✘

Question Number : 71 Question Id : 3330086431 Display Question Number : Yes Is Question Mandatory : No Calculator : None Response Time : N.A Think Time : N.A Minimum Instruction Time : 0

What do you mean by duty cycle?

Options :

1. ✓ Ratio of on time and total time period
2. ✘ Ratio of off time and total time period
3. ✘ On time
4. ✘ Off time

Question Number : 72 Question Id : 3330086432 Display Question Number : Yes Is Question Mandatory : No Calculator : None Response Time : N.A Think Time : N.A Minimum Instruction Time : 0

Typically oscilloscope represents _____

Options :

1. ✘ Current and time
2. ✘ Resistance and time
3. ✓ Voltage and time
4. ✘ Power and time

Question Number : 73 Question Id : 3330086433 Display Question Number : Yes Is Question Mandatory : No Calculator : None Response Time : N.A Think Time : N.A Minimum Instruction Time : 0

Stray capacitance effects can be minimized by _____

Options :

1. ✘ Making use of an inductance
2. ✘ Connecting a resistance in series
3. ✔ Shielding and grounding
4. ✘ Using a galvanometer

Question Number : 74 Question Id : 3330086434 Display Question Number : Yes Is Question Mandatory : No Calculator : None Response Time : N.A Think Time : N.A Minimum Instruction Time : 0

In serial communication, if the time interval to transmit one bit is $10 \mu \text{ sec}$. What is the time to transmit an 8-bit word?

Options :

1. ✘ $8 \mu \text{ sec}$
2. ✔ $80 \mu \text{ sec}$

3. ✘ 0.8 μ sec

4. ✘ 0.008 μ sec

Question Number : 75 Question Id : 3330086435 Display Question Number : Yes Is Question Mandatory : No Calculator : None Response Time : N.A Think Time : N.A Minimum Instruction Time : 0

A node having only outgoing branches is called as _____.

Options :

1. ✔ Input node

2. ✘ Output node

3. ✘ Incoming node

4. ✘ Outgoing node

Question Number : 76 Question Id : 3330086436 Display Question Number : Yes Is Question Mandatory : No Calculator : None Response Time : N.A Think Time : N.A Minimum Instruction Time : 0

Signal flow graphs:

Options :

1. ✓ They apply to linear systems
2. ✗ The equation obtained may or may not be in the form of cause or effect
3. ✗ Arrows are not important in the graph
4. ✗ They cannot be converted back to block diagram

Question Number : 77 Question Id : 3330086437 Display Question Number : Yes Is Question Mandatory : No Calculator : None Response Time : N.A Think Time : N.A Minimum Instruction Time : 0

Feedback control systems are:

Options :

1. ✗ Insensitive to both forward and feedback path parameter changes
2. ✗ Less sensitive to feedback path parameter changes than to forward path parameter changes
3. ✓ Less sensitive to forward path parameter changes than to feedback path parameter changes
4. ✗

Equally sensitive to forward feedback path parameter changes

Question Number : 78 Question Id : 3330086438 Display Question Number : Yes Is Question Mandatory : No Calculator : None Response Time : N.A Think Time : N.A Minimum Instruction Time : 0

Which of the test signals are best utilized by the stability analysis_____

Options :

1. ✓ Impulse

2. ✗ Step

3. ✗ Ramp

4. ✗ Parabolic

Question Number : 79 Question Id : 3330086439 Display Question Number : Yes Is Question Mandatory : No Calculator : None Response Time : N.A Think Time : N.A Minimum Instruction Time : 0

Consider the loop transfer function $K(s+6)/(s+3)(s+5)$ In the root locus diagram the centroid will be located at:

Options :

1. ✗ -4

2. ✘ -1

3. ✔ -2

4. ✘ -3

Question Number : 80 Question Id : 3330086440 Display Question Number : Yes Is Question Mandatory : No Calculator : None Response Time : N.A Think Time : N.A Minimum Instruction Time : 0

Zero initial condition for a system means _____.

Options :

1. ✘ Input reference signal is zero

2. ✘ Zero stored energy

3. ✘ The initial movement of moving parts

4. ✔ System is at rest and no energy is stored in any of its components

Question Number : 81 Question Id : 3330086441 Display Question Number : Yes Is Question

Mandatory : No Calculator : None Response Time : N.A Think Time : N.A Minimum Instruction

Time : 0

In a bode magnitude plot, which one of the following slopes would be exhibited at high frequencies by a 4th order all-pole system?

Options :

-80 dB/decade

1. ✓

-40 dB/decade

2. ✗

40 dB/decade

3. ✗

80 dB/decade

4. ✗

Question Number : 82 Question Id : 3330086442 Display Question Number : Yes Is Question

Mandatory : No Calculator : None Response Time : N.A Think Time : N.A Minimum Instruction

Time : 0

For Nyquist contour, the size of radius is _____

Options :

25

1. ✗

0

2. ✗

1

3. ✗

4. ✓ ∞

Question Number : 83 Question Id : 3330086443 Display Question Number : Yes Is Question Mandatory : No Calculator : None Response Time : N.A Think Time : N.A Minimum Instruction Time : 0

Derivative error compensation:

Options :

- 1. ✘ Improvement in transient response
- 2. ✘ Reduction in steady state error
- 3. ✘ Reduction in settling time
- 4. ✓ Increase in damping constant

Question Number : 84 Question Id : 3330086444 Display Question Number : Yes Is Question Mandatory : No Calculator : None Response Time : N.A Think Time : N.A Minimum Instruction Time : 0

Which one of the following controllers produces the output in three terms?

Options :

1. ✘

Proportional controller

2. ✘ Proportional Derivative controller

3. ✘ Proportional Integral controller

4. ✔ Proportional Integral Derivative controller

Question Number : 85 Question Id : 3330086445 Display Question Number : Yes Is Question Mandatory : No Calculator : None Response Time : N.A Think Time : N.A Minimum Instruction Time : 0

Which component of a servo motor is responsible for providing feedback?

Options :

1. ✔ Encoder

2. ✘ Transistor

3. ✘ Capacitor

4. ✘ Diode

Question Number : 86 Question Id : 3330086446 Display Question Number : Yes Is Question Mandatory : No Calculator : None Response Time : N.A Think Time : N.A Minimum Instruction Time : 0

The figure shown below is a circuit diagram of _____ controller?

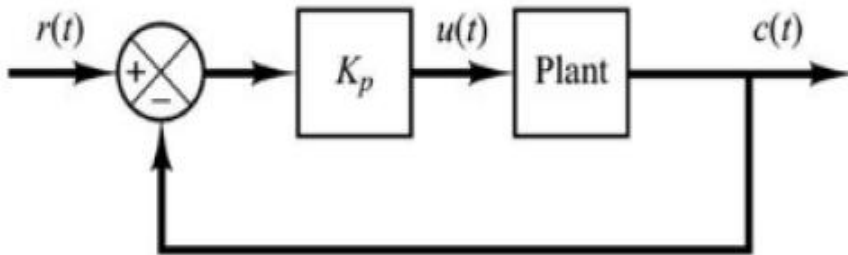

Options :

1. ✓ Proportional
2. ✗ Proportional integral
3. ✗ Proportional Derivative
4. ✗ PID Controller

Question Number : 87 Question Id : 3330086447 Display Question Number : Yes Is Question Mandatory : No Calculator : None Response Time : N.A Think Time : N.A Minimum Instruction Time : 0

In which type of system does power transmission takes place through compressed air?

Options :

1. ✘ Fluid power system

2. ✘ Hydraulic system

3. ✔ Pneumatic system

4. ✘ Stepper motor

Question Number : 88 Question Id : 3330086448 Display Question Number : Yes Is Question Mandatory : No Calculator : None Response Time : N.A Think Time : N.A Minimum Instruction Time : 0

What pumps hydraulic oil to the hydraulic circuit?

Options :

1. ✔ Flow control valve

2. ✘ Oil reservoir

3. ✘ Rotatory pumps

4. ✘ Pressure gauge

Question Number : 89 Question Id : 3330086449 Display Question Number : Yes Is Question Mandatory : No Calculator : None Response Time : N.A Think Time : N.A Minimum Instruction Time : 0

Magnetic sector analyzer is a part of

Options :

1. ✘ NMR spectroscopy
2. ✔ Mass spectroscopy
3. ✘ IR spectroscopy
4. ✘ UV spectroscopy

Question Number : 90 Question Id : 3330086450 Display Question Number : Yes Is Question Mandatory : No Calculator : None Response Time : N.A Think Time : N.A Minimum Instruction Time : 0

The target materials which are suited for X-ray generation are

Options :

1. ✔ Silver
2. ✘ Thorium

3. ✘ Uranium

4. ✘ Nickel

Question Number : 91 Question Id : 3330086451 Display Question Number : Yes Is Question Mandatory : No Calculator : None Response Time : N.A Think Time : N.A Minimum Instruction Time : 0

Which type of vapour is stored in Mercury lamp ?

Options :

1. ✔ Mercury vapour

2. ✘ Hydrogen vapour

3. ✘ Xe

4. ✘ Ozone

Question Number : 92 Question Id : 3330086452 Display Question Number : Yes Is Question Mandatory : No Calculator : None Response Time : N.A Think Time : N.A Minimum Instruction Time : 0

Epoxy material in fibre optics is intended for _____

Options :

1. ✘ Better optical properties

2. ✘ Better reflection

3. ✔ Better sealing

4. ✘ Reducing noise

Question Number : 93 Question Id : 3330086453 Display Question Number : Yes Is Question Mandatory : No Calculator : None Response Time : N.A Think Time : N.A Minimum Instruction Time : 0

Which among the following characteristics of Laser light specifies the precise movement of all individual light waves together through time and space?

Options :

1. ✘ Monochromatic

2. ✘ Directional

3. ✔ Coherent

4. ✘ Brightness

Question Number : 94 Question Id : 3330086454 Display Question Number : Yes Is Question Mandatory : No Calculator : None Response Time : N.A Think Time : N.A Minimum Instruction Time : 0

A device which converts electrical energy in the form of a current into optical energy is called as _____.

Options :

1. ✓ Optical source

2. ✗ Optical coupler

3. ✗ Optical isolator

4. ✗ Circulator

Question Number : 95 Question Id : 3330086455 Display Question Number : Yes Is Question Mandatory : No Calculator : None Response Time : N.A Think Time : N.A Minimum Instruction Time : 0

In the fiber optic link, power transfer from one fiber to another and from fiber to detector must take place with _____ coupling efficiency.

Options :

1. ✓ Maximum

2. ✗ Stable

3. ✘ Minimum

4. ✘ Unpredictable

Question Number : 96 Question Id : 3330086456 Display Question Number : Yes Is Question Mandatory : No Calculator : None Response Time : N.A Think Time : N.A Minimum Instruction Time : 0

Recombination of electron-hole produces _____ in LEDs.

Options :

1. ✔ Photons

2. ✘ Protons

3. ✘ Nucleus

4. ✘ Junction capacitance

Question Number : 97 Question Id : 3330086457 Display Question Number : Yes Is Question Mandatory : No Calculator : None Response Time : N.A Think Time : N.A Minimum Instruction Time : 0

Beer Lambert's law gives the relation between which of the following?

Options :

1.

- ✘ Reflected radiation and concentration
- 2. ✘ Scattered radiation and concentration
- 3. ✔ Energy absorption and concentration
- 4. ✘ Energy absorption and reflected radiation

Question Number : 98 Question Id : 3330086458 Display Question Number : Yes Is Question Mandatory : No Calculator : None Response Time : N.A Think Time : N.A Minimum Instruction Time : 0

Normal EEG frequency range is _____

Options :

- 1. ✘ 50-500Hz
- 2. ✔ 0.5-50HZ
- 3. ✘ 0.05-5Hz
- 4. ✘ 1-200Hz

Question Number : 99 Question Id : 3330086459 Display Question Number : Yes Is Question Mandatory : No Calculator : None Response Time : N.A Think Time : N.A Minimum Instruction Time : 0

Electroencephalogram is obtained from bioelectrical signals from the?

Options :

1. ✓ Brain
2. ✗ Heart
3. ✗ Muscles
4. ✗ Retina

Question Number : 100 Question Id : 3330086460 Display Question Number : Yes Is Question Mandatory : No Calculator : None Response Time : N.A Think Time : N.A Minimum Instruction Time : 0

Which of the following is the frequency range of ultrasonic detection?

Options :

1. ✓ 100 KHz to 50MHz
2. ✗ 50 KHz to 100 KHz
3. ✗ 100 GHz to 200 GHz

10 KHz to 100 MHz

4. ✘

Question Number : 101 Question Id : 3330086461 Display Question Number : Yes Is Question Mandatory : No Calculator : None Response Time : N.A Think Time : N.A Minimum Instruction Time : 0

_____ is a part of the human temperature control system

Options :

1. ✘ Digestive system

2. ✔ Perspiration system

3. ✘ Leg movement

4. ✘ Ear

Question Number : 102 Question Id : 3330086462 Display Question Number : Yes Is Question Mandatory : No Calculator : None Response Time : N.A Think Time : N.A Minimum Instruction Time : 0

When nuclear radiations pass through, gas ionization is produced.' This is the principle of which of the following detectors?

Options :

1. ✘

Proportional counter

2. ✘ Flow counter

3. ✔ Geiger Muller counter

4. ✘ Scintillation counter

Question Number : 103 Question Id : 3330086463 Display Question Number : Yes Is Question Mandatory : No Calculator : None Response Time : N.A Think Time : N.A Minimum Instruction Time : 0

Which among the following transducer is an example of active transducer?

Options :

1. ✘ LDR (Light dependant sensor)

2. ✘ Strain gauge

3. ✘ Hall effect sensor

4. ✔ Photovoltaic cell

Question Number : 104 Question Id : 3330086464 Display Question Number : Yes Is Question Mandatory : No Calculator : None Response Time : N.A Think Time : N.A Minimum Instruction Time : 0

The ac series circuit is composed of a resistance of $20\ \Omega$, inductive reactance of $40\ \Omega$ and capacitive reactance of $15\ \Omega$. If a current of 1 Ampere is flowing, then what is the applied voltage value?

Options :

1. ✘ 320V

2. ✘ 22V

3. ✔ 32V

4. ✘ 220V

Question Number : 105 Question Id : 3330086465 Display Question Number : Yes Is Question Mandatory : No Calculator : None Response Time : N.A Think Time : N.A Minimum Instruction Time : 0

An ammeter is inserted in _____

Options :

1. ✔ Series in a circuit and current to be measured flows through it

2. ✘ Series in a circuit and part of the current to be measured flows through it

3. ✖ Parallel in a circuit and current to be measured flows through it

4. ✖ Parallel in a circuit and only part of the current to the measured flows through it.

Question Number : 106 Question Id : 3330086466 Display Question Number : Yes Is Question Mandatory : No Calculator : None Response Time : N.A Think Time : N.A Minimum Instruction Time : 0

Using masons gain formula, find the non-touching loops in terms of loop gains

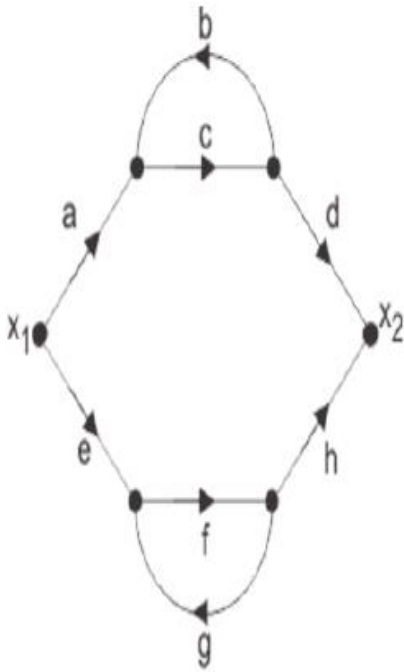

Options :

1. ✖ $acbd,efgh$

2. ✖ $acdhfe, bc$

3. ✖ $acdhfe, fg$

4. ✓ bc, fg

Question Number : 107 Question Id : 3330086467 Display Question Number : Yes Is Question Mandatory : No Calculator : None Response Time : N.A Think Time : N.A Minimum Instruction Time : 0

A force sensor has a sensitivity of 0.01 mV/N. If the sensor outputs a voltage of 2 mV, what is the corresponding force (in Newtons)?

Options :

1. ✗ 100N

2. ✗ 150N

3. ✓ 200N

4. ✗ 250N

Question Number : 108 Question Id : 3330086468 Display Question Number : Yes Is Question Mandatory : No Calculator : None Response Time : N.A Think Time : N.A Minimum Instruction Time : 0

The device shown here is most likely to be ____

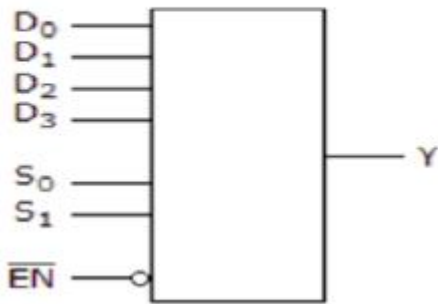

Options :

1. ✓ 4×1 Multiplexer
2. ✗ 6×1 Multiplexer
3. ✗ 4×1 Demultiplexer
4. ✗ 6×1 Demultiplexer

Question Number : 109 Question Id : 3330086469 Display Question Number : Yes Is Question Mandatory : No Calculator : None Response Time : N.A Think Time : N.A Minimum Instruction Time : 0

The system $AX=B$ has a unique solution if

Options :

1. ✗ $\rho(A) = \rho(A|B) < \text{No. of Variables}$

2. ✗

$$\rho(A) < \rho(A|B) = \text{No. of Variables}$$

$$\rho(A) < \rho(A|B) < \text{No. of Variables}$$

3. ✘

$$\rho(A) = \rho(A|B) = \text{No. of Variables}$$

4. ✔

Question Number : 110 Question Id : 3330086470 Display Question Number : Yes Is Question Mandatory : No Calculator : None Response Time : N.A Think Time : N.A Minimum Instruction Time : 0

The system of equations $3x + 2y + z = 0, x + 4y + z = 0, 2x + y + 4z = 0$ is

Options :

1. ✘ Inconsistent

2. ✔ Has only the trivial solution $x = y = z = 0$

3. ✘ Reduced to single equation and solution does not exist

4. ✘ Determinant of the coefficient matrix is zero

Question Number : 111 Question Id : 3330086471 Display Question Number : Yes Is Question

Mandatory : No Calculator : None Response Time : N.A Think Time : N.A Minimum Instruction Time : 0

If $A = \begin{bmatrix} 1 & 0 \\ 0 & 1 \end{bmatrix}$, $B = \begin{bmatrix} 0 & 1 \\ -1 & 0 \end{bmatrix}$ and $C = \begin{bmatrix} \cos\theta & \sin\theta \\ -\sin\theta & \cos\theta \end{bmatrix}$ then

Options :

$$C = A\cos\theta - B\sin\theta$$

1. ✘

$$C = A\sin\theta + B\cos\theta$$

2. ✘

$$C = A\sin\theta - B\cos\theta$$

3. ✘

$$C = A\cos\theta + B\sin\theta$$

4. ✔

Question Number : 112 Question Id : 3330086472 Display Question Number : Yes Is Question Mandatory : No Calculator : None Response Time : N.A Think Time : N.A Minimum Instruction Time : 0

If $f = \tan^{-1}(xy)$ then $\left(\frac{\partial f}{\partial x}\right)_{(1,2)} = \text{-----}$

Options :

$$\frac{1}{5}$$

1. ✘

$$\frac{2}{5}$$

2. ✔

3. ✘ $\frac{3}{5}$

4. ✘ $\frac{4}{5}$

Question Number : 113 Question Id : 3330086473 Display Question Number : Yes Is Question Mandatory : No Calculator : None Response Time : N.A Think Time : N.A Minimum Instruction Time : 0

Let S be a closed surface for which $\oiint \vec{r} \cdot \hat{n} \, dS = 1$, then the volume enclosed by the surface is __

Options :

1. ✘ 1

2. ✔ $\frac{1}{3}$

3. ✘ $\frac{2}{3}$

4. ✘ 3

Question Number : 114 Question Id : 3330086474 Display Question Number : Yes Is Question Mandatory : No Calculator : None Response Time : N.A Think Time : N.A Minimum Instruction Time : 0

The general solution of the differential equation $x^2 \frac{d^2y}{dx^2} - 2x \frac{dy}{dx} + 2y = 4$ is

Options :

1. ✓ $y = c_2x^2 + c_1x + 2$

2. ✗ $y = c_2x + \frac{c_1}{x^2} + 2$

3. ✗ $y = c_1x^2 + c_2x + 4$

4. ✗ $y = c_2x + \frac{c_1}{x^2} + 4$

Question Number : 115 Question Id : 3330086475 Display Question Number : Yes Is Question Mandatory : No Calculator : None Response Time : N.A Think Time : N.A Minimum Instruction Time : 0

Auxiliary Equation for the Cauchy Euler Equation $(x^2D^2 + xD + 4)y = 0$ is _____

Options :

1. ✓ $\theta^2 + 4 = 0$

2. ✗ $\theta^2 + 9 = 0$

3. ✗

$$\theta^2 + 16 = 0$$

$$\theta^2 + 25 = 0$$

4. ✖

Question Number : 116 Question Id : 3330086476 Display Question Number : Yes Is Question Mandatory : No Calculator : None Response Time : N.A Think Time : N.A Minimum Instruction Time : 0

In Method of Variation of Parameters, $A = -\int \frac{VRdx}{W}$. If $V = \sin x, R = \sec x, W = 1$ then $A = \underline{\hspace{1cm}}$

Options :

1. ✖ $\sin x$

2. ✖ $\cos x$

3. ✖ $\log(\sin x)$

4. ✔ $\log(\cos x)$

Question Number : 117 Question Id : 3330086477 Display Question Number : Yes Is Question Mandatory : No Calculator : None Response Time : N.A Think Time : N.A Minimum Instruction Time : 0

Cauchy Reimann Equations for an Analytic function are

Options :

$$u_x = -v_y; u_y = -v_x$$

1. ✓

$$u_x = v_x; u_y = v_y$$

2. ✗

$$u_x = v_y; u_y = -v_x$$

3. ✗

$$u_x = -v_x; u_y = -v_y$$

4. ✗

Question Number : 118 Question Id : 3330086478 Display Question Number : Yes Is Question Mandatory : No Calculator : None Response Time : N.A Think Time : N.A Minimum Instruction Time : 0

For the function $\frac{\sin z}{z^4}$, the point $z = 0$ is

Options :

A pole of order 4

1. ✗

A pole of order 1

2. ✗

A pole of order 2

3. ✗

A pole of order 3

4. ✓

Question Number : 119 Question Id : 3330086479 Display Question Number : Yes Is Question Mandatory : No Calculator : None Response Time : N.A Think Time : N.A Minimum Instruction Time : 0

The variance for continuous probability function $f(x) = x^2 e^{-x}$ when $x \geq 0$ is

Options :

1. ✘ 1

2. ✘ 0

3. ✔ 3

4. ✘ 2

Question Number : 120 Question Id : 3330086480 Display Question Number : Yes Is Question Mandatory : No Calculator : None Response Time : N.A Think Time : N.A Minimum Instruction Time : 0

Line of Regression of y on x

Options :

$$y - \bar{y} = \frac{\sigma_y}{\sigma_x} (x - \bar{x})$$

1. ✘

2. ✔

$$y - \bar{y} = r \frac{\sigma_y}{\sigma_x} (x - \bar{x})$$

$$y - \bar{y} = \frac{1}{r} \frac{\sigma_y}{\sigma_x} (x - \bar{x})$$

3. ✖

$$x - \bar{x} = r \frac{\sigma_x}{\sigma_y} (y - \bar{y})$$

4. ✖