

30/01/2024

Evening



Corporate Office : Aakash Tower, 8, Pusa Road, New Delhi-110005 | Ph.: 011-47623456

Memory Based Answers & Solutions

Time : 3 hrs.

for

M.M. : 300

JEE (Main)-2024 (Online) Phase-1

(Physics, Chemistry and Mathematics)

IMPORTANT INSTRUCTIONS:

- (1) The test is of **3 hours** duration.
- (2) This test paper consists of 90 questions. Each subject (PCM) has 30 questions. The maximum marks are 300.
- (3) This question paper contains **Three Parts**. **Part-A** is Physics, **Part-B** is Chemistry and **Part-C** is **Mathematics**. Each part has only two sections: **Section-A** and **Section-B**.
- (4) **Section - A** : Attempt all questions.
- (5) **Section - B** : Attempt any 05 questions out of 10 Questions.
- (6) **Section - A (01 – 20)** contains 20 multiple choice questions which have **only one correct answer**. Each question carries **+4 marks** for correct answer and **-1 mark** for wrong answer.
- (7) **Section - B (21 – 30)** contains 10 **Numerical value** based questions. The answer to each question should be rounded off to the **nearest integer**. Each question carries **+4 marks** for correct answer and **-1 mark** for wrong answer.

PHYSICS

SECTION - A

Multiple Choice Questions: This section contains 20 multiple choice questions. Each question has 4 choices (1), (2), (3) and (4), out of which **ONLY ONE** is correct.

Choose the correct answer:

1. A block of mass 1 kg is ascended on inclined plane by distance of 10 m as shown in diagram, with help of force of 10 N along the incline. Find work done against the friction.

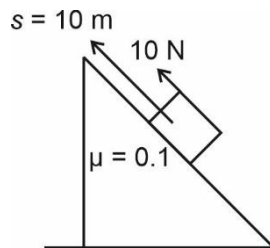

- (1) 10 J (2) $5\sqrt{3}$ J
(3) 5 J (4) $(10 - 5\sqrt{3})$ J

Answer (3)

Sol. $f = \mu mg \cos 60^\circ$

$$= 0.1 \times 1 \times 10 \times \frac{1}{2} = 0.5 \text{ N}$$

$$W = fs \cos\theta = .5 \times 10 \cos 180 = -5 \text{ J}$$

2. A force of 10 N is applied on a three block system as shown. Find the two tensions T_1 and T_2 .

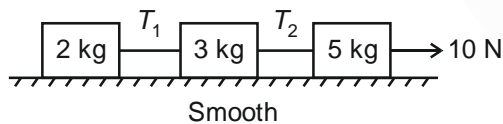

- (1) 2 N, 5 N
(2) 5 N, 2 N
(3) 3 N, 4 N
(4) 4 N, 3 N

Answer (1)

Sol. $a = \frac{F_{\text{net}}}{M} = \frac{10}{10} = 1 \text{ m/s}^2$

$$\Rightarrow T_1 = 2 \text{ kg} \times 1 \text{ m/s}^2 = 2 \text{ N}$$

$$\text{and } T_2 = (2 + 3) \text{ kg} \times 1 \text{ m/s}^2 = 5 \text{ N}$$

3. The slope of graph between stopping potential (V_0) and frequency of incident photon (f) in photoelectric effect is ($h = \text{planck's constant}$, $e = \text{charge on electron}$)

- (1) $\frac{h}{e}$
(2) $\frac{h}{2e}$
(3) $\frac{2h}{e}$
(4) $\frac{e}{h}$

Answer (1)

Sol. From Einstein photoelectric equation

$$hf = \phi_0 + eV_0$$

$$V_0 = \frac{h}{e}f - \frac{\phi}{e}$$

$$\therefore \text{Slope} = \frac{h}{e}$$

4. Ice at temperature -10°C is converted to steam at 100°C , the curve plotted between temperature (T) and time (t) when it is being heated by constant power source is

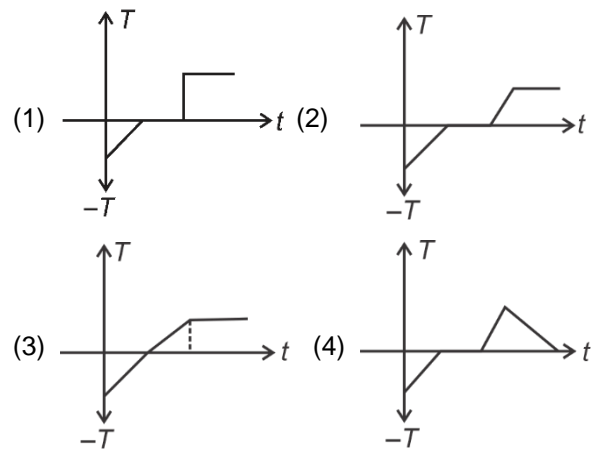

Answer (2)

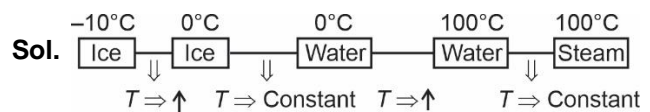

5. Two particles are projected from a tower of height 400 m & angles 45° & 60° with horizontal. If they have same time of flight, find the ratio of their velocities.

- (1) $\sqrt{\frac{3}{2}}$
- (2) $\sqrt{\frac{5}{2}}$
- (3) $\sqrt{\frac{3}{4}}$
- (4) 1

Answer (1)

Sol. For time of flight to be same they have same velocity along y-axis.

$$v_1 \sin 45 = v_2 \sin 60$$

$$\frac{v_1}{v_2} = \frac{\sqrt{3}}{\sqrt{2}}$$

6. In given circuit, reading of voltmeter is 1 V, then resistance of voltmeter is

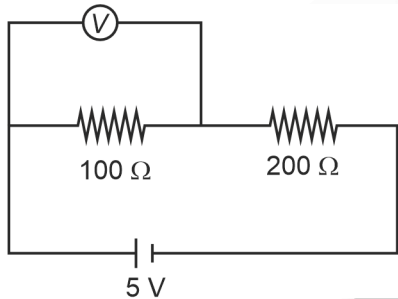

- (1) 100Ω
- (2) 200Ω
- (3) $200\sqrt{5} \Omega$
- (4) 50Ω

Answer (1)

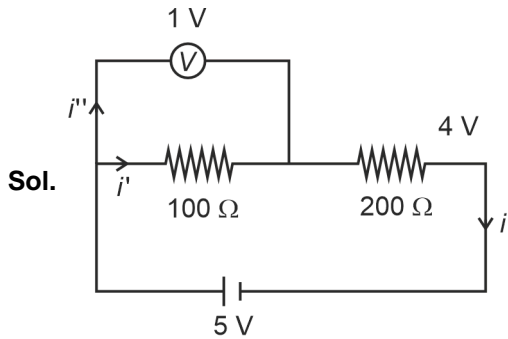

$$i = \frac{4}{200} \text{ A}$$

$$i' = \frac{1}{100} \text{ A}$$

$$i'' = i - i'$$

$$= \frac{4}{200} - \frac{1}{100}$$

$$i'' = \frac{2}{200} \text{ A}$$

$$R_V i'' = 1 \text{ volt}$$

$$R_V = \frac{1}{2} \times 200 = 100 \Omega$$

7. In the circuit shown if the potential drop in forward bias across Si and Ge diodes are 0.7 V and 0.3 V, find the potential difference across $2.5 \text{ k}\Omega$ resistor.

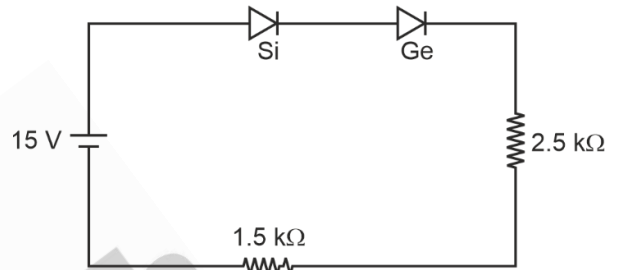

- (1) 9.25 V
- (2) 6.25 V
- (3) 8.75 V
- (4) 9.75 V

Answer (3)

Sol. $i = \frac{15 - 0.7 - 0.3}{2.5 + 1.5} \text{ mA}$

$$= \frac{7}{2} \text{ mA}$$

$$\therefore V = 2.5 \times \frac{7}{2} \text{ volts}$$

$$V = 8.75 \text{ volts}$$

8. A point source is placed at origin. Its intensity at distance of 2 cm from source is I then intensity at distance 4 cm from the source shall be.

- (1) $\frac{I}{2}$
- (2) $\frac{I}{16}$
- (3) $\frac{I}{4}$
- (4) I

Answer (3)

Sol. $I = \frac{\rho}{4\pi r^2}$

$$\frac{I_1}{I_2} = \frac{4^2}{2^2}$$

$$\frac{I}{I_2} = 4$$

$$I_2 = \frac{I}{4}$$

9. The Pressure (P) versus volume (V) of thermodynamic process shown in figure. The select the correct options (Take $\gamma = 1.1$)

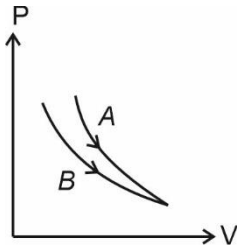

- (1) For process A : $PV = \text{constant}$
For process B : $PV^\gamma = \text{constant}$
- (2) For process A : $PV^{\frac{1}{\gamma}} = \text{constant}$
For process B : $PV = \text{constant}$
- (3) For process A : $PV^{1.05} = \text{constant}$
For process B : $PV^\gamma = \text{constant}$
- (4) For process A : $PV^{1.2} = \text{constant}$
For process B : $PV = \text{constant}$

Answer (4)

Sol. (Slope of A) > (Slope of B)

For $PV^\gamma = \text{constant}$

$$\text{Slope} = -x \left(\frac{P}{V} \right)$$

10. Voltage across a 5Ω resistor is given as $V = 200 \sin(100\pi t)$. Find out time required for current through it to change from $\frac{i_0}{2}$ to i_0 [i_0 is peak current]

- (1) $\frac{1}{300}$ s (2) $\frac{1}{600}$ s
- (3) $\frac{1}{150}$ s (4) $\frac{1}{1200}$ s

Answer (1)

Sol. Angle traversed by phasor = 60°

$$\Rightarrow \Delta t = \frac{T}{6} = \frac{\pi}{3 \times 100\pi}$$

$$= \frac{1}{300} \text{ s}$$

11. A nucleus of mass M breaks into 3 nuclei with a mass defect of Δm . Find the speed of each daughter nuclei if they have equal mass.

- (1) $c\sqrt{\frac{6\Delta m}{(M-\Delta m)}}$
- (2) $c\sqrt{\frac{2\Delta m}{(M-\Delta m)}}$
- (3) $c\sqrt{\frac{3\Delta m}{(M-\Delta m)}}$
- (4) $c\sqrt{\frac{\Delta m}{(M-\Delta m)}}$

Answer (2)

Sol. Total kinetic energy = Δmc^2

$$\therefore 3 \times \frac{1}{2} \frac{(M-\Delta m)}{3} v^2 = \Delta mc^2$$

$$v^2 = \frac{2\Delta mc^2}{(M-\Delta m)}$$

$$\therefore v = c\sqrt{\frac{2\Delta m}{(M-\Delta m)}}$$

12. In a vernier calliper 49 main scale divisions are equal to 50 vernier scale divisions. If one main scale division is 0.5 mm, then the vernier constant is

- (1) 0.01 mm (2) 0.1 mm
- (3) 0.1 cm (4) 0.01 cm

Answer (1)

Sol. 49 MSD = 50 VSD

$$1 \text{ VSD} = \frac{49}{50} \text{ MSD}$$

$$\text{LC} = 1 \text{ MSD} - 1 \text{ VSD}$$

$$= \frac{1}{50} \text{ MSD}$$

$$= \frac{1}{50} \times 0.5 \text{ mm}$$

$$= 0.01 \text{ mm}$$

13. 6×10^5 J of electromagnetic energy is incident on a surface in time t_0 . Find the total momentum imparted if the surface is completely absorbing.

- (1) 2×10^{-3} kg m/s
- (2) 10^{-3} kg m/s
- (3) 10^{-2} kg m/s
- (4) 2×10^{-4} kg m/s

Answer (1)

Sol. I : intensity

$$\Rightarrow I \cdot A \cdot t_0 = E$$

$$\Rightarrow n \cdot \frac{hc}{\lambda} \cdot t_0 = E$$

$$\Rightarrow n \cdot \frac{h \cdot t_0}{\lambda} = \frac{E}{c} = \frac{6 \times 10^5}{3 \times 10^8} = 2 \times 10^{-3}$$

14. A particle is placed on upward parabolic curve $y = \frac{x^2}{4}$ having co-efficient of friction (μ) = 0.5. What should be maximum height above x-axis so that it does not slip.

- (1) $\frac{1}{4}$ m
- (2) $\frac{1}{2}$ m
- (3) $\frac{1}{3}$ m
- (4) $\frac{3}{4}$ m

Answer (1)

Sol. $y = \frac{x^2}{4}$

$$\frac{dy}{dx} = \frac{x}{2} = \tan \theta$$

FBD for particle:

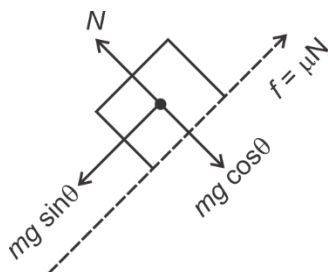

at equilibrium = $mg \sin \theta = mg \cos \theta$. μ

$$\tan \theta = \mu$$

$$\frac{x}{2} = \mu = \frac{1}{2}$$

$$x = 1 \text{ m}$$

$$\text{then } y = h = \frac{x^2}{4} = \frac{1}{4} \text{ m}$$

15. Two polaroids are placed at angle of 45° to each other. If unpolarized light of intensity I_0 falls as one polaroid, then intensity of light leaving second polaroid.

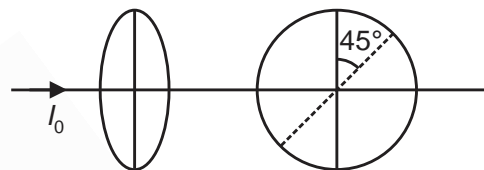

- (1) $\frac{I_0}{2}$
- (2) $\frac{I_0}{2\sqrt{2}}$
- (3) $\frac{I_0}{4}$
- (4) $\frac{I_0}{8}$

Answer (3)

Sol. From 1st polaroid $\rightarrow \frac{I_0}{2}$

$$\text{From 2nd polaroid } \rightarrow \frac{I_0}{2} \cos^2 45^\circ = \frac{I_0}{4}$$

16. If a vector is having magnitude equal to that of $\vec{A} = 4\hat{i} + 3\hat{j}$ and is parallel to $\vec{B} = 3\hat{i} + 4\hat{j}$, then if 3 & x are component of this vector in first quadrant, then find x.

- (1) 3
- (2) 4
- (3) 5
- (2) 2

Answer (2)

Sol. $\vec{C} = |\vec{A}| \hat{B}$

$$= 5 \times \frac{3\hat{i} + 4\hat{j}}{5}$$

$$= 3\hat{i} + 4\hat{j}$$

$$\Rightarrow x = 4$$

17. Mass can be expressed as $M = C^p G^{-1/2} \hbar^{1/2}$, where C is speed of light, G is gravitational constant and \hbar is Planck's constant. Find p.

(1) 1

(2) 0.5

(3) -1

(4) -0.5

Answer (2)

Sol. $[C] = [LT^{-1}]$

$$[G] = [M^{-1} L^3 T^{-2}]$$

$$[\hbar] = [ML^2 T^{-1}]$$

$$[M] = [LT^{-1}]^p [M^{-1} L^3 T^{-2}]^{-1/2} [ML^2 T^{-1}]^{1/2}$$

$$-p + 1 - \frac{1}{2} = 0$$

$$p = \frac{1}{2}$$

18.

19.

20.

SECTION - B

Numerical Value Type Questions: This section contains 10 Numerical based questions. The answer to each question should be rounded-off to the nearest integer.

21. A square loop of side 1 m is carrying current of 5 A as shown. If the magnetic field at centre is $x\sqrt{2} \times 10^{-7} T$, find x

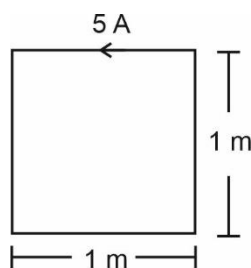

Answer (40)

Sol. $B = 4 \times \frac{\mu_0 i}{4\pi(0.5)} (\sin 45^\circ + \sin 45^\circ)$

$$= 8\sqrt{2} \times 10^{-7} \times 5$$

$$= 40\sqrt{2} \times 10^{-7} T$$

22. A planet of mass of $\frac{1}{6}$ th of earth's mass, radius of

$\frac{1}{3}$ rd of earth's radius. If escape speed for earth is

11.2 km/s, then escape speed for the planet shall be _____ km/s (nearest integer).

Answer (8)

Sol. $v_e = \sqrt{\frac{2GM}{r}}$

$$v_e' = \sqrt{\frac{2GM'}{r'}}$$

$$\frac{11.2}{v_e'} = \sqrt{\frac{M(r/3)}{(M/6)r}} = \sqrt{2}$$

$$\frac{11.2}{\sqrt{2}} = v_e' \approx 8 \text{ km/s}$$

23. An electron in 5th excited state of He⁺ atom moves to 1st excited state. Find number of possible spectral lines formed.

Answer (10)

Sol. Transition is from 6 \rightarrow 2

$$\therefore \text{No of line} = \frac{5 \times 4}{2}$$

$$\Rightarrow 10$$

24. A negatively charged particle ($m, -q$) rotates around a positively charged infinite line charge as

shown. Time period of the particle is $\sqrt{\frac{x\pi^3 \epsilon_0 m r^2}{\lambda q}}$.

Find x.

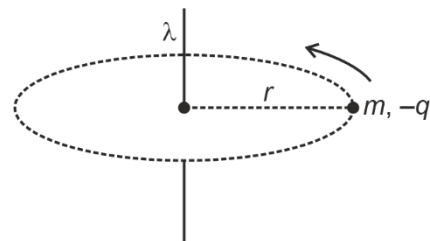

Answer (8)

Sol. $E = \frac{\lambda}{2\pi\epsilon_0 r}$

$$\Rightarrow \frac{\lambda q}{2\pi\epsilon_0 r} = \frac{mv^2}{r}$$

$$\Rightarrow v = \sqrt{\frac{\lambda q}{2\pi\epsilon_0 m}}$$

$$\Rightarrow T = \frac{2\pi r}{v} = 2\pi r \sqrt{\frac{2\pi\epsilon_0 m}{\lambda q}}$$

$$= \sqrt{\frac{8\pi^3 \epsilon_0 m r^2}{\lambda q}}$$

25. A simple pendulum of length 4 m is located at a height R above the surface of earth. The time period of the simple pendulum is $2\pi\sqrt{\frac{8}{x}}$ seconds.

Find x .

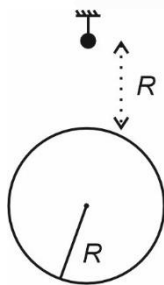

Answer (5)

Sol. $g = \frac{g_0}{4}$

$$\Rightarrow T = 2\pi\sqrt{\frac{l}{g}}$$

$$= 2\pi\sqrt{\frac{l}{\frac{g_0}{4}}}$$

$$= 2\pi\sqrt{1.6}$$

26.

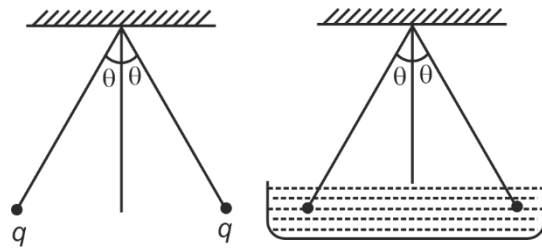

Two identical charged particles connected with light threads from common point as shown. After putting arrangement in liquid, the angular separation between blocks does not change. If relative density of particles is 1.4 and that of liquid is 0.7, dielectric constant of liquid is

Answer (2)

Sol.

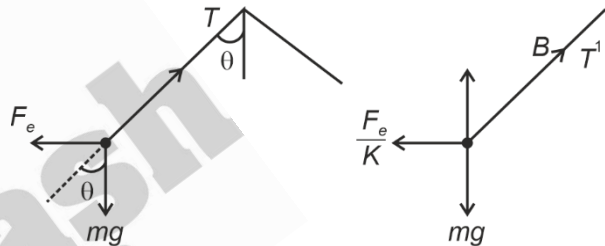

$$mg \sin \theta = F_e \cos \theta \quad \dots(i)$$

$$(mg - B) \sin \theta = \frac{F_e}{K} \cos \theta \quad \dots(ii)$$

$$\frac{mg}{mg - B} = K$$

$$\frac{\sigma}{\sigma - \rho} = K$$

$$\frac{1.4}{1.4 - 0.7} = K$$

$$\boxed{K = 2}$$

27.

28.

29.

30.

CHEMISTRY

SECTION - A

Multiple Choice Questions: This section contains 20 multiple choice questions. Each question has 4 choices (1), (2), (3) and (4), out of which **ONLY ONE** is correct.

Choose the correct answer :

- Why KMnO_4 shows colour?
 - Due to d-d transition
 - Due to metal to ligand charge transfer
 - Due to ligand to metal charge transfer
 - Due to F-centre

Answer (3)

Sol. Colour of KMnO_4 is due to LMCT (Ligand to metal charge transfer).

- C is added to solution of A and B, find mole fraction of C.

$$(1) \frac{n_C}{n_A + n_B + n_C} \quad (2) \frac{n_C}{n_A \cdot n_B + n_C}$$

$$(3) \frac{n_C}{n_A \cdot n_C + n_B} \quad (4) \frac{n_C}{n_A + n_B}$$

Answer (1)

Sol. In a mixture of A, B and C

$$\text{Mole fraction} = \frac{n_C}{n_A + n_B + n_C}$$

- IUPAC name of compound $\text{CH}_3 - \underset{\text{CH}_3}{\text{CH}} - \text{C} \equiv \text{CH}$ is

- 2-Methylbutyne
- 3-Methylbut-1-yne
- 2-methylbutene
- 3-methylbutane

Answer (2)

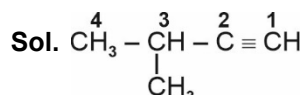

3-Methylbut-1-yne

- Which of the following solution will have lowest freezing point?

- 180 g glucose in 1 L solution
- 180 g of benzoic acid in 1 L solution
- 180 g of CH_3COOH in 1 L solution
- 180 g sucrose in 1 L solution

Answer (3)

Sol. $\Delta T_f = (i)(k_f)(m)$

Molality is highest for 180 gm of CH_3COOH in 1 litre solution.

- Arrange the following according to their decreasing oxidising power.

- $\text{BrO}_4^-, \text{IO}_4^-, \text{ClO}_4^-$
- $\text{ClO}_4^- > \text{IO}_4^- > \text{BrO}_4^-$
 - $\text{BrO}_4^- > \text{IO}_4^- > \text{ClO}_4^-$
 - $\text{IO}_4^- > \text{BrO}_4^- > \text{ClO}_4^-$
 - $\text{BrO}_4^- > \text{ClO}_4^- > \text{IO}_4^-$

Answer (2)

Sol. The reduction potential of BrO_4^- , IO_4^- and ClO_4^- are 1.75 V, 1.65 V and 1.20 V respectively. Thus BrO_4^- , has the highest oxidising power and ClO_4^- has the lowest oxidising power among the given perchlorates.

- Salicylaldehyde forms from phenol by reacting with which reagent?

- CO_2 , NaOH
- CHCl_3 , NaOH
- CCl_4 , NaOH
- H_2O , H^+

Answer (2)

Sol. In Reimer Tiemann reaction phenol reacts with CHCl_3 , NaOH to give salicylaldehyde.

7. Complete the following reactions and find major products A and B

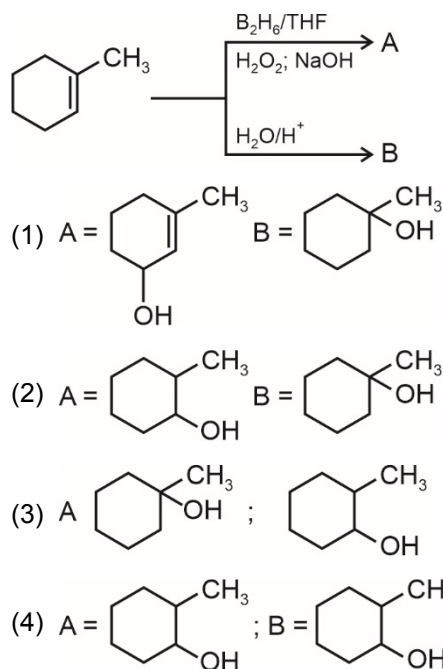

Answer (2)

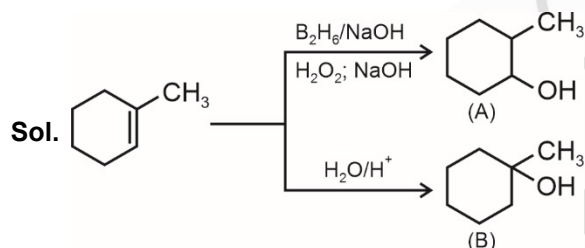

Correct answer is option (2)

8. What is the correct IUPAC name of the given compound?

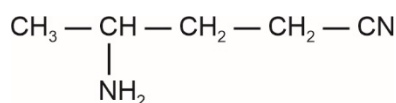

- (1) 4-Aminopentanenitrile
 (2) 2-Aminopentanenitrile
 (3) 3-Aminobutanenitrile
 (4) 2-Aminobutanenitrile

Answer (1)

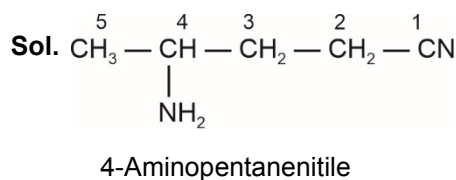

9. In the given reactions A and B respectively are:

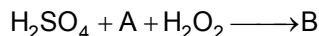
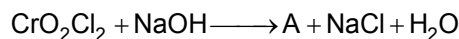

- (1) Na_2CrO_4 and CrO_5
 (2) CrO_5 and Na_2CrO_4
 (3) Na_2CrO_4 and CrO_3
 (4) $\text{Na}_2\text{Cr}_2\text{O}_7$ and Na_2CrO_4

Answer (1)

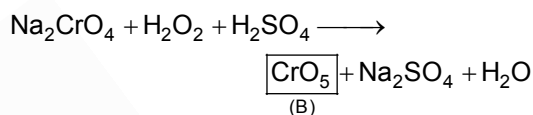
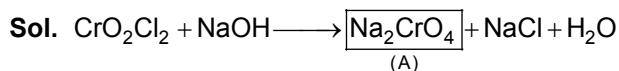

$$\therefore \text{A} = \text{Na}_2\text{CrO}_4$$

$$\text{B} = \text{CrO}_5$$

10. Which of the following has square pyramidal shape?

- (1) PCl_5 (2) BrF_5
 (3) PF_5 (4) $[\text{Ni}(\text{CN})_4]^{2-}$

Answer (2)

Sol. BrF_5 has 1 lone pair and 5 bond pairs

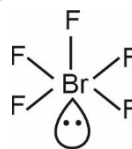

So, geometry is octahedral, shape is square pyramidal.

11. Find out correct order of stability for given carbocations

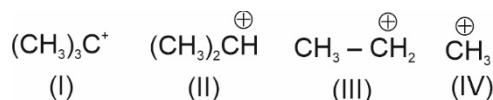

- (1) II > I > III > IV (2) I > II > III > IV
 (3) IV > III > II > I (4) I > II > IV > III

Answer (2)

Sol. Stability of carbocation : $3^\circ > 2^\circ > 1^\circ > \text{methyl}$

12. **Statement I** : Halogen attached to bulky group undergo S_N2 reaction.

Statement II : Secondary alkyl halide react with excess C_2H_5OH undergo S_N1 reaction.

- (1) Both statements are true
 (2) Statement I is true, II is false
 (3) Both statements are false
 (4) Statement I is false, Statement II is true

Answer (4)

Sol. When halogen attached to bulky group back side attack is not possible so S_N2 reaction does not takes place.

Secondary alkyl halide reacts with excess of ethanol undergo S_N1 reaction.

13. Consider the following statements.

Statement I : Since electronegativity of $F > H$, so dipole moment of $NF_3 > NH_3$.

Statement II : Lone pair dipole in NH_3 is not in the direction of resultant bond dipole while in case of NF_3 the lone pair dipole is in the direction of resultant bond dipole.

- (1) SI : True (2) SI : True
 SII : False SII : True
 (3) SI : False (4) SI : False
 SII : False SII : True

Answer (3)

Sol. Dipole moment of $NH_3 > NF_3$ because in case of NH_3 the lone pair dipole is in the direction of resultant bond dipole.

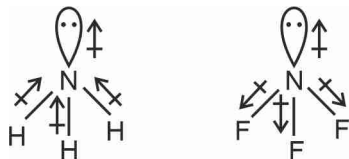

14. Magnetic moment due to the motion of the electron in n^{th} orbit of Bohr atom is proportional to n^x . The value of x is

- (1) 0
 (2) 1
 (3) 2
 (4) 3

Answer (2)

Sol. Magnetic moment $\mu = \frac{e}{2m} \times L$

Where L is the angular momentum

$$L = \frac{nh}{2\pi}$$

$$\therefore \mu \propto n$$

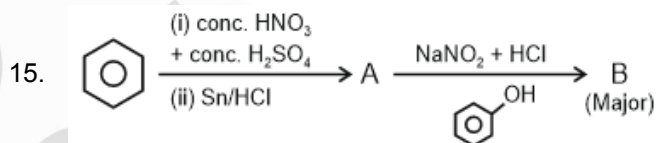

A and B respectively are :

- (1) $A = \text{C}_6\text{H}_5\text{NH}_2$, $B = \text{C}_6\text{H}_4(\text{OH})\text{N}(\text{N}=\text{N})\text{Ph}$
- (2) $A = \text{C}_6\text{H}_5\text{NH}_2$, $B = \text{HO-C}_6\text{H}_4\text{-N}(\text{N}=\text{N})\text{-C}_6\text{H}_4\text{-OH}$
- (3) $A = \text{C}_6\text{H}_5\text{NH}_2$, $B = \text{C}_6\text{H}_3(\text{OH})_2\text{N}(\text{N}=\text{N})\text{Ph}$
- (4) $A = \text{C}_6\text{H}_5\text{COOH}$, $B = \text{C}_6\text{H}_4(\text{OH})\text{N}(\text{N}=\text{N})\text{Ph}$

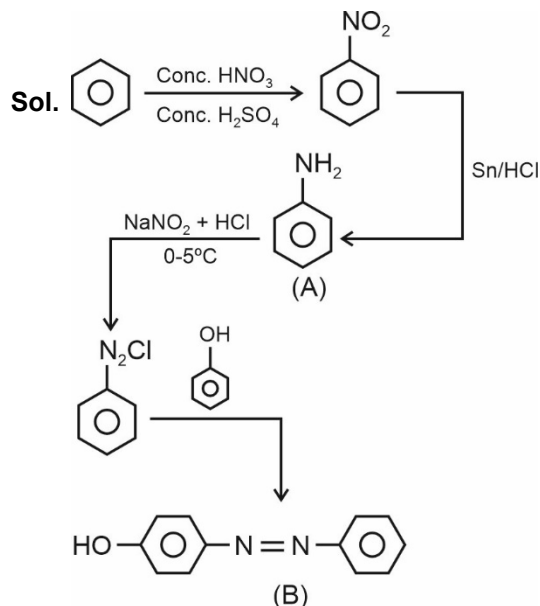
Answer (1)

16. Which of the following is a purification method which is based on solubility of compound.

- (1) Distillation
- (2) Sublimation
- (3) Crystallization
- (4) Column Chromatography

Answer (3)

Sol. Insoluble impurities can be separated by filtration followed by crystallization where soluble compound crystallizes in pure form.

17. Statement 1 : H_2Te is more acidic than H_2S

Statement 2 : H_2Te has more B.D.E than H_2S

- (1) Statement 1 and 2 both are correct
- (2) Statement 1 and 2 both are incorrect
- (3) Statement 1 is incorrect and statement 2 is correct
- (4) Statement 1 is correct and statement 2 is incorrect

Answer (4)

Sol. H_2Te has less bond dissociation energy than H_2S , that's why H_2Te is more acidic than H_2S

18. What is the structure of $\text{Mn}_2(\text{CO})_{10}$?

- (1) Two square pyramidal units joined by bridging CO ligands
- (2) Two square pyramidal units joined by Mn-Mn bond
- (3) Two tetrahedral units joined by Mn-Mn bond
- (4) Two square planar units joined by Mn-Mn bond

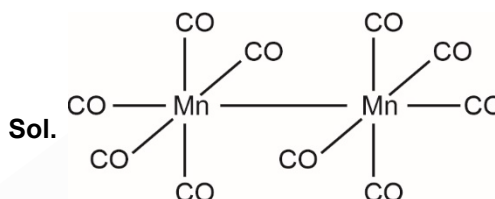
Answer (2)

19. What are the products of the reaction of m-chlorobenzaldehyde with 50% KOH?

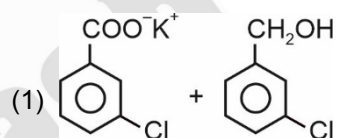
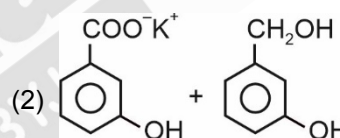
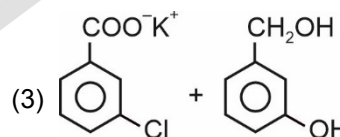
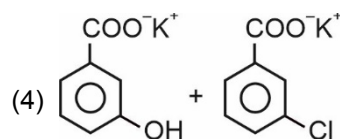
- (1) 
- (2) 
- (3) 
- (4) 

Answer (1)

Sol. The reaction follows the Cannizzaro reaction mechanism.

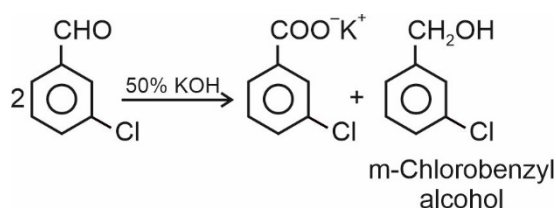

20. **Statement-I:** There is regular increase in chemical reactivity from group 1 to group 18.

Statement-II: Oxides of group-1 elements are basic and oxide of group 17 are acidic

- (1) Both statement-I and statement-II are true
- (2) Statement-I is true and statement-II is false
- (3) Statement-I is false and statement-II is true
- (4) Statement-I and statement-II both are false

Answer (3)

Sol. The chemical reactivity of elements decreases and then increases from group 1 to 18 generally metal oxides are basic and nonmetal oxides are acidic.

SECTION - B

Numerical Value Type Questions: This section contains 10 Numerical based questions. The answer to each question should be rounded-off to the nearest integer.

21. How many spectral lines are obtained when an electron in He⁺ ion Jumps from n = 5 to n = 1.

Answer (10)

Sol. Number of spectral lines

$$= \frac{(\Delta n)(\Delta n + 1)}{2}$$

$$= \frac{(4)(5)}{2} = 10$$

22. What is the value of enthalpy change (ΔH) (in kJ/mole) for given reaction-

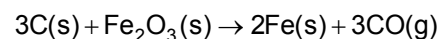

Given :

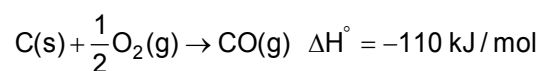
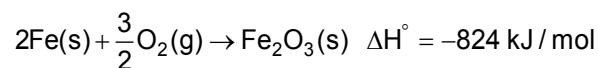

Answer (494)

Sol. $\Delta H^\circ = 3(-110) - (-824)$
 $= -330 + 824 = 494(\text{kJ/mole})$

23. Number of elements which give flame test from following

Sr, Cu, Co, Ca, Ni, Fe

Answer (4)

Sol. Cu : Green with blue centre

Ca : Brick red

Sr : Crimson red

Fe : Gold, when very hot such as an electric arc bright blue, or green turning to orange-brown

24. Consider the given reaction

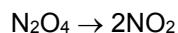

Initial conc. of N₂O₄ = 3M

Concentration of N₂O₄ is 2.75 M

after 30 sec., find out rate of formation of NO₂ during this interval (in mol lit⁻¹ min⁻¹) (Nearest integer)

Answer (1)

Sol. Rate of consumption of N₂O₄ = $\frac{3 - 2.75}{30}$

$$\text{Rate of formation of NO}_2 = \frac{0.25}{30} \times 2 \times 60$$

$$= 1 \text{ mol lit}^{-1} \text{ min}^{-1}$$

25. How many of the following shows disproportionation reactions?

H₂O₂, Ag, Cu⁺, K⁺, F₂, Cl₂, ClO₃⁻

Answer (4)

Sol. Atom in its highest or lowest oxidation state does not disproportionate.

H₂O₂, Cu⁺, Cl₂, ClO₃⁻

H₂O₂ → O⁻¹ can go to O²⁻ and O₂

Cu⁺ → Cu = +1 to +2 and 0

⁰Cl₂ → to Cl⁻¹ and +1, +3, +5, +7

⁺⁵ClO₃⁻ → Cl⁻¹ and Cl⁺⁷

- 26.
- 27.
- 28.
- 29.
- 30.

Sol. $f(x) = \frac{x}{(1+x^4)^{1/4}}$

$$f(f(x)) = \frac{x}{(1+2x^4)^{1/4}}$$

$$f(f(f(x))) = \frac{x}{(1+3x^4)^{1/4}}$$

$$\therefore g(x) = f(f(f(f(x)))) = \frac{x}{(1+4x^4)^{1/4}}$$

$$\therefore I = \int_0^{\sqrt{2\sqrt{5}}} \frac{x^3}{(1+4x^4)^{1/4}} dx$$

Let $1 + 4x^4 = t^4 \Rightarrow 4x^3 dx = t^3 dt$

$$\therefore I = \int_1^3 \frac{t^2}{4} dt = \frac{1}{12} (3^3 - 1^3) = \frac{13}{6}$$

5. If 1st term of a GP is 'a' and 3rd term is 'b' and in 2nd GP 1st term is 'a' and 5th term is 'b' and 11th term of 1st GP common to which term of 2nd GP

- (1) 24 (2) 25
(3) 21 (4) 18

Answer (3)

Sol. First term of 1st GP is a and common ratio be r_1
First term of 2nd GP is a and common ratio be r_2

3rd term of 1st GP = $ar_1^2 = b$

5th term of 2nd GP = $ar_2^4 = b$

$$\Rightarrow ar_1^2 = ar_2^4$$

$$\Rightarrow r_1 = \pm r_2^2$$

11th term of 1st GP = ar_1^{10}

$$= a(\pm r_2^2)^{10}$$

$$= ar_2^{20}$$

Hence, it will be common to 21st term of 2nd GP

6. $z^{1985} + z^{100} + 1 = 0$ and

$$z^3 + 2z^2 + 2z + 1 = 0$$

then number of common roots of equation is

- (1) 1 (2) 2
(3) 3 (4) 4

Answer (2)

Sol. The roots of equation $z^{1985} + z^{100} + 1 = 0$ be ω & ω^2 and also satisfies $z^3 + 2z^2 + 2z + 1 = 0$

$\therefore \omega$ & ω^2 are common solutions.

(ω is cube root of unity)

\therefore 2 solutions

7. If $x^2 - y^2 + 2hxy + 2gx + 2fy + c = 0$ is the locus of points such that it is equidistance from the lines $x + 2y - 8 = 0$ and $2x + y + 7 = 0$, then value of $h + g + f + c$ is

- (1) 15 (2) -15
(3) 20 (4) -20

Answer (3)

Sol. Combined equation of angle bisectors of lines is

$$\left[\left(\frac{2x+y+7}{\sqrt{5}} \right) - \left(\frac{x+2y-8}{\sqrt{5}} \right) \right] \left[\left(\frac{2x+y+7}{\sqrt{5}} \right) + \left(\frac{x+2y-8}{\sqrt{5}} \right) \right] = 0$$

$$\Rightarrow (2x+y+7)^2 - (x+2y-8)^2 = 0$$

$$\Rightarrow (3x+3y-1)(x-y+15) = 0$$

$$\Rightarrow 3x^2 - 3y^2 + 15 + 44x + 46y + 0xy = 0$$

$$\Rightarrow x^2 - y^2 + \frac{44x}{3} + \frac{46y}{3} + 5 = 0$$

$$\Rightarrow h = 0, g = \frac{22}{3}, f = \frac{23}{3}, c = 5$$

$$\Rightarrow h + f + g + c = \frac{45}{3} + 5 = 20$$

8. $A = \begin{bmatrix} x & 0 & 0 \\ 0 & y & 0 \\ 0 & 0 & z \end{bmatrix}$

$$\frac{x}{\sin \theta} = \frac{y}{\sin\left(\theta + \frac{2\pi}{3}\right)} = \frac{z}{\sin\left(\theta + \frac{4\pi}{3}\right)}$$

Then

Statement 1: $T_r(A) = 0$

Statement 2: $T_r(\text{adj}(\text{adj } A))$

- (1) Statement 1 & 2 are true
(2) Statement 1 is true
(3) Statement 2 is true
(4) None of these

Answer (1)

Sol. $x = k \sin \theta$

$$y = k \sin\left(\theta + \frac{2\pi}{3}\right)$$

$$z = k \sin\left(\theta + \frac{4\pi}{3}\right)$$

$$x + y + z = k \left[\sin \theta + \sin\left(\theta + \frac{2\pi}{3}\right) + \sin\left(\theta + \frac{4\pi}{3}\right) \right]$$

22. If $\vec{a} = \hat{i} + \alpha\hat{j} + \beta\hat{k}$ $|\vec{b}|^2 = 6$ and angle between \vec{a} and \vec{b} is $\frac{\pi}{4}$. If $\vec{a} \cdot \vec{b} = 3$ then $(\alpha^2 + \beta^2) |\vec{a} \times \vec{b}|^2$ is

Answer (18)

Sol. $\vec{a} \cdot \vec{b} = |\vec{a}| |\vec{b}| \cos\theta = 3$

$$= \sqrt{1 + \alpha^2 + \beta^2} \cdot \sqrt{6} \frac{1}{\sqrt{2}} = 3$$

$$\Rightarrow 1 + \alpha^2 + \beta^2 = 3$$

$$\Rightarrow \alpha^2 + \beta^2 = 2$$

Also $|\vec{a}| = \sqrt{1 + \alpha^2 + \beta^2} = \sqrt{3}$

$$\Rightarrow |\vec{a} \times \vec{b}| = |\vec{a}| |\vec{b}| \sin\theta$$

$$= \sqrt{3} \times \sqrt{6} \times \frac{1}{\sqrt{2}} = 3 \Rightarrow |\vec{a} \times \vec{b}|^2 = 9$$

$$\Rightarrow (\alpha^2 + \beta^2) |\vec{a} \times \vec{b}|^2 = 2 \times 9 = 18$$

23. If $(y-2)^2 = (x-1)$ and $x-2y+4=0$, then find the area bounded by the curves between the coordinate axis in first quadrant (in sq. unit).

Answer (05.00)

Sol. We have to find shaded area

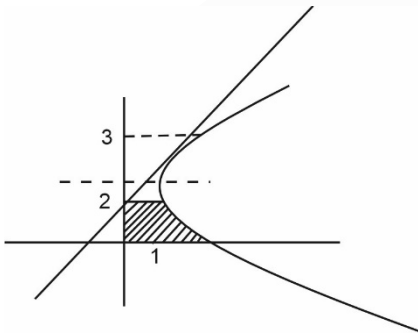

$$\Rightarrow \int_0^2 [(y-2)^2 + 1] dy + \int_2^3 \left[((y-2)^2 + 1) - \left(\frac{2y-4}{2} \right) \right] dy$$

$$= \frac{(y-2)^3}{3} + y \Big|_0^2 + \frac{(y-2)^3}{3} + y - \left(\frac{y^2}{2} - 2y \right) \Big|_2^3$$

$$= \left(2 + \frac{8}{3} \right) + \left[\left(\frac{1}{3} + 3 \right) - \left(\frac{9}{2} - 6 \right) \right] - [2 - (2-4)] = 5$$

24. If $3\sin(A+B) = 4\sin(A-B)$ and

If $\tan A = k \tan B$, then value of k is _____

Answer (7)

Sol. $\frac{\sin(A+B)}{\sin(A-B)} = \frac{4}{3}$

$$\frac{\sin(A+B) + \sin(A-B)}{\sin(A+B) - \sin(A-B)} = \frac{7}{1}$$

[\therefore Using componendo and dividendo]

$$\frac{2\sin A \cos B}{2\cos A \sin B} = 7$$

$$\frac{\tan A}{\tan B} = 7$$

$$k = 7$$

25. If $x(x^2 + 3|x| + 5|x-1| + 6|x-2|) = 0$ then, find the number of solutions of the given equation.

Answer (1)

Sol. $x = 0$ is the solution

(I) $x < 0$

$$(x^2 - 3x - 5(x-1) - 6(x-2)) = 0$$

$$x^2 - 14x + 17 = 0$$

All the roots are greater than 0

(II) $0 < x < 1$

$$x^2 + 3x - 5(x-1) - 6(x-2) = 0$$

$$x^2 - 8x + 17 = 0$$

$$D < 0$$

No solution in this interval

(III) $1 < x < 2$

$$x^2 + 3x + 5(x-1) - 6(x-2) = 0$$

$$x^2 + 2x + 7 = 0$$

$$D < 0$$

No Solution

(IV) $x > 2$

$$x^2 + 3x + 5(x-1) + 6(x-2) = 0$$

$$x^2 + 14x - 17 = 0$$

All the roots is less than 2

Hence, $x = 0$ is the only solution.

26. A set $R = \{1, 2, 3, 4\}$ is given then find the number of symmetric relation which are not reflexive relation.

Answer (960)

Sol. $R = \{1, 2, 3, 4\}$

here number of elements $n = 4$

Number of relations which are symmetric but not

$$\text{reflexive} = 2^{\frac{n(n+1)}{2}} - 2^{\frac{n^2-n}{2}}$$

$$= 2^{\frac{4.5}{2}} - 2^6$$

$$= 2^{10} - 2^6$$

$$= 1024 - 64 = 960$$

27. If $f(x) = ae^{2x} + be^x + cx$, $f(0) = -1$, $f(\ln 2) = 4$, if

$$\int_0^{\ln 4} (f(x) - cx) dx = \frac{39}{2} \text{ find } |a + b + c|$$

Answer (25)

Sol. $\therefore f(x) = ae^{2x} + be^x + cx$

$$\Rightarrow f(x) = 2ae^{2x} + be^x + c$$

$$\therefore f(\ln 2) = 4$$

$$\Rightarrow 4 = 2a(4) + b(2) + c$$

$$\Rightarrow 8a + 2b + c = 4 \quad \dots(i)$$

$$\therefore \int_0^{\ln 4} (ae^{2x} + be^x) dx = \frac{39}{2}$$

$$\Rightarrow \frac{a}{2} [e^{2x}]_0^{\ln 4} + b(e^x)_0^{\ln 4} = \frac{39}{2}$$

$$\Rightarrow \frac{a}{2} [16 - 1] + b(4 - 1) = \frac{39}{2}$$

$$\Rightarrow \frac{15a}{2} + 3b = \frac{39}{2}$$

$$\Rightarrow \frac{5a}{2} + b = \frac{13}{2}$$

$$\Rightarrow 5a + 2b = 13 \quad \dots(ii)$$

Also $f(0) = -1$

$$\Rightarrow -1 = a + b \quad \dots(iii)$$

From (ii) & (iii)

$$5a + 5b = -5$$

$$5a + 2b = 13$$

$$3b = -18$$

$$\Rightarrow \boxed{b = -6}$$

$$\Rightarrow \boxed{a = 5}$$

$$\therefore \boxed{c = -24}$$

$$|a + b + c| = 25$$

28.

29.

30.