



**General Instructions :**

Read the following instructions very carefully and strictly follow them :

- (i) This question paper contains 33 questions. All questions are compulsory.
- (ii) This question paper is divided into five Sections - A, B, C, D and E.
- (iii) In Section A - Questions no. 1 to 16 are multiple choice (MCQ) type questions, carrying 1 mark each.
- (iv) In Section B - Questions no. 17 to 21 very short answer (VSA) type questions, carrying 2 marks each.
- (v) In Section C - Questions no. 22 to 28 are short answer (SA) type questions, carrying 3 marks each.
- (vi) In Section D - Questions no. 29 and 30 are case-based questions carrying 4 marks each. Each question has subparts with internal choice in one subpart.
- (vii) In Section E - Questions no. 31 to 33 are long answer (LA) type questions carrying 5 marks each.
- (viii) There is no overall choice. However, an internal choice has been provided in 1 question in Section B, 1 question in Section C, 2 questions in Section D and 3 questions in Section E. A candidate has to attempt only one of the alternatives in such questions.
- (ix) Wherever necessary, neat and properly labelled diagrams should be drawn.

**SECTION A**

Questions no. 1 to 16 are Multiple Choice (MCQ) type Questions, carrying 1 mark each. 16×1=16

1. A human male decides to adopt a surgical method for contraception. Identify the point in the diagram where a cut would be made and tied.

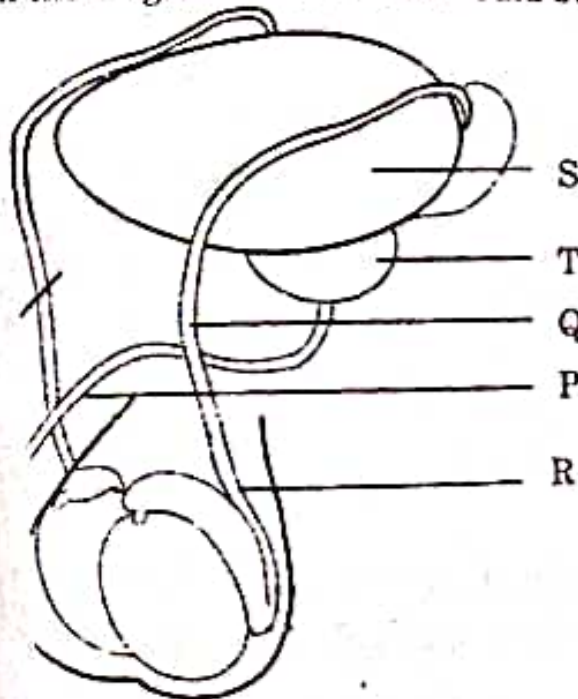

- (a) Point S
- (b) Point R
- (c) Point Q
- (d) Point P



2. Which of the following structures is well-developed in a mature seed of black pepper ?
- (a) Perisperm (b) Thalamus  
(c) Sepals (d) Peduncle

3. Observe the following line diagram depicting the 28 days menstrual cycle of a healthy young woman.

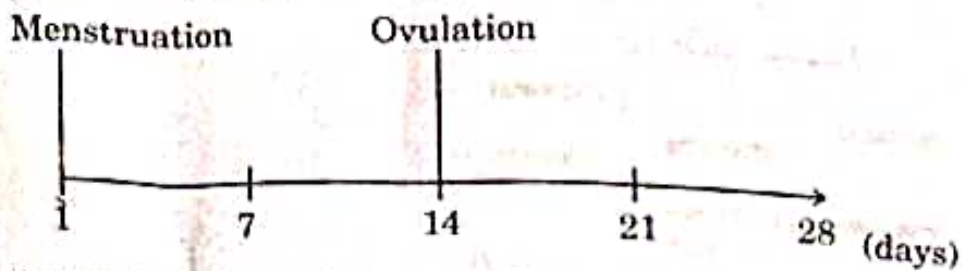

Select the option of days on which this woman would be most and least fertile.

- |     | <i>Most fertile days</i> | <i>Least fertile days</i> |
|-----|--------------------------|---------------------------|
| (a) | 14 - 21                  | 1 - 7                     |
| (b) | 10 - 17                  | 21 - 28                   |
| (c) | 1 - 7                    | 14 - 21                   |
| (d) | 21 - 28                  | 7 - 14                    |
4. Which one of the following was not present during the Mesozoic Era of the geological time scale ?
- (a) Ferns (b) Horsetails  
(c) Ginkgos (d) Bryophytes
5. Identify the element used by Hershey and Chase to label the protein in their experiment, from the following options :
- (a)  $P^{32}$  (b)  $S^{32}$   
(c)  $S^{35}$  (d)  $P^{35}$







7.

The given schematic illustration shows three steps 'P', 'Q' and 'R' of the polymerase chain reaction.

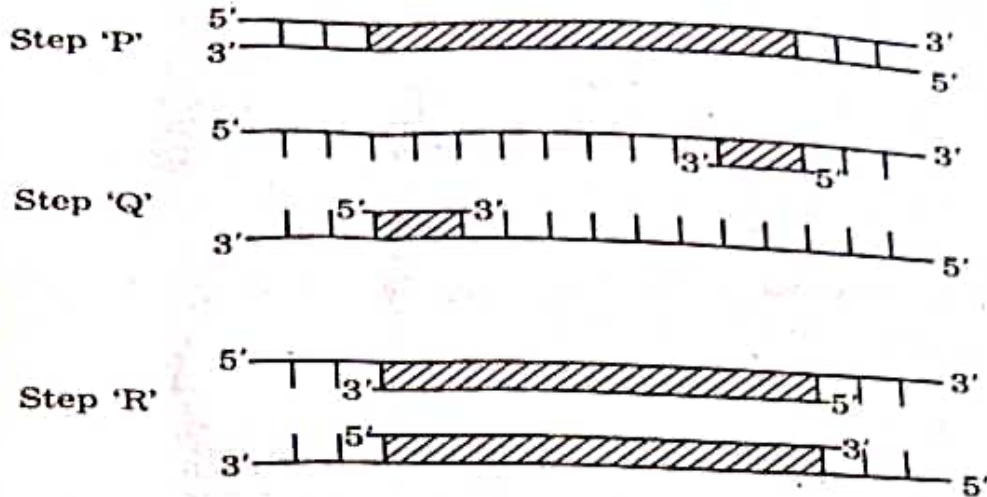

Which of the following statements are correct with reference to the illustration given above ?

- (i) Step 'P' is showing denaturation at low temperature.
  - (ii) Step 'Q' is a denaturation of DNA strand at high temperature, followed by annealing.
  - (iii) Step 'R' is an extension of DNA in presence of thermostable DNA polymerase.
  - (iv) Step 'Q' is extension with two sets of primers.
- (a) (i) and (iii) only
  - (b) (ii) and (iii) only
  - (c) (ii) only
  - (d) (i) only

57/3/3



Page 9

P.T.O.

8. Identify the fungus that ripens the famous 'Roquefort' cheese :
- Saccharomyces cerevisiae*
  - Propionibacterium sharmanii*
  - Monascus purpureus*
  - Penicillium notatum*
9. Select the options which is/are incorrect statement(s) with respect to T-lymphocytes in the human body.
- They are a type of white blood cells.
  - They are produced in bone marrow.
  - They remain active at all times in the body.
  - They mature in the bone marrow.
- (a) (i) and (iv) only                      (b) (iii) only  
(c) (iv) only                                  (d) (iii) and (iv) only
10. Which one among the following regions is *not* a hotspot of biodiversity ?
- The Indo-Burma Region
  - Jaintia Hills in Meghalaya
  - The Western Ghats and Sri Lanka
  - The Himalayas
11. Human settlement often leads to habitat loss which leads to fragmentation, forming smaller patches of habitats. Select the statements that describe how a small patch differs from a large patch of the same habitat.
- Invasive species will never be seen here.
  - Population of large animals decreases.
  - Biodiversity decreases.
  - Competition from surrounding habitats increases.
- (a) (ii), (iii) and (iv) only  
(b) (ii) and (iv) only  
(c) (i) and (iii) only  
(d) (i), (ii) and (iii) only

12. Identify the option that gives the correct type of evolution exhibited by the two animals shown, living in the same habitat in Australia.



Mouse



Marsupial mouse

- (a) Convergent Evolution
- (b) Disruptive Selection
- (c) Divergent Evolution
- (d) Homologous Ancestry

*For Questions number 13 to 16, two statements are given — one labelled as Assertion (A) and the other labelled as Reason (R). Select the correct answer to these questions from the codes (a), (b), (c) and (d) as given below.*

- (a) Both Assertion (A) and Reason (R) are true and Reason (R) is the correct explanation of the Assertion (A).
  - (b) Both Assertion (A) and Reason (R) are true, but Reason (R) is *not* the correct explanation of the Assertion (A).
  - (c) Assertion (A) is true, but Reason (R) is false.
  - (d) Assertion (A) is false, but Reason (R) is true.
13. *Assertion (A)* : The Covid-19 virus has a shorter life-span and evolves into new strains at a fast speed.
- Reason (R)* : RNA being unstable, mutates at a faster rate.



14. **Assertion (A) :** For DNA sequencing, the total DNA from a cell is isolated and converted into random fragments of relatively smaller sizes.
- Reason (R) :** Human genome is said to have approximately  $3 \times 10^9$  bp and the total estimated cost for sequencing is very high.
15. **Assertion (A) :** Biologists are sure about how many prokaryotic species are living now.
- Reason (R) :** The conventional taxonomic methods are not suitable for identifying microbial species.
16. **Assertion (A) :** Mary Mallon continued to spread typhoid for many years.
- Reason (R) :** *Salmonella typhi* generally enters the small intestine through food and water contaminated with it.

### SECTION B

17. (a) Explain the process of the development of a male gametophyte in an angiosperm.
- (b) Why is it called a male gametophyte? 2
18. (a) Name the two institutes which developed the technology of biogas production in India.
- (b). Explain the main principle used in this technology. 2

19. Given below is a food web that involves nine organisms.

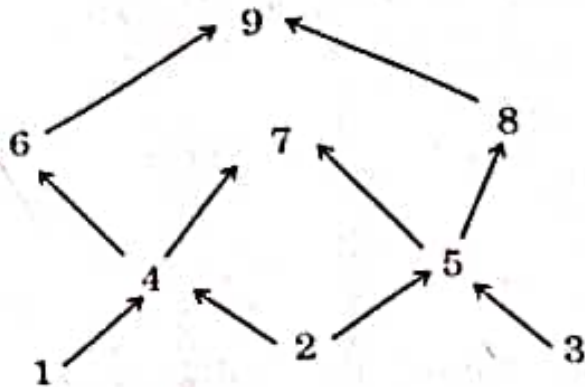

- (a) Identify two producers and two carnivores shown in the food web.
- (b) Is it possible to make an ecological pyramid depicting this food web? Give reason in support of your answer. 2
20. (a) 'Insertional inactivation' is a method to detect recombinant DNA. Explain the method. 2
- OR**
- (b) Explain how recombinant DNA technology is used to detect a disease even before any clinical symptom appears. 2
21. On August 22 in the year 2022, 3358 fires were detected in the Amazon rainforests. Write one short-term and one long-term effect of this event on the biotic and abiotic components of the environment. 2



## SECTION C

22. Explain the following population interactions with the help of one example each :

3

- (a) Brood Parasitism
- (b) Co-evolution of mutualists

23. (a) Write the scientific name of the nematode that infests the tobacco plants and the part that it infests.

(b) How is *Agrobacterium* used to protect tobacco plant from this attack ?

3

24.

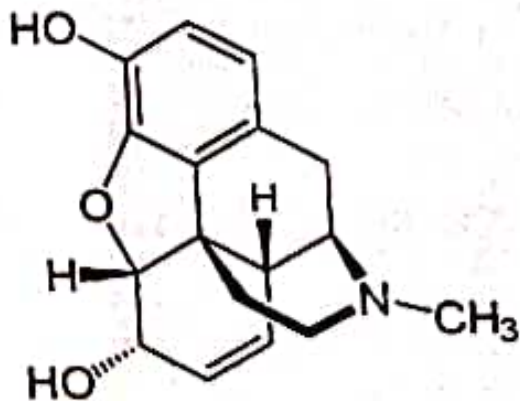

(a) Name the category of drugs represented by the chemical structure given above.

(b) If the methyl group is substituted by acetyl group we get a bitter crystalline compound. Name the compound.

(c) Name the natural source of these compounds.

(d) State the harmful effects of this class of drugs on the human body.

3

57/3/3



Q. (a) Darwin's theory of Natural Selection is widely accepted but some limitations have been identified by modern biologists. Mention the limitations identified.

(b) Name and state the most accepted theory of evolution in modern times.

(c) Mention any two ways the limitations identified in Darwin's theory of evolution are explained in modern biology.

3

Q. (a) (i) How many types of RNA polymerases are there in a eukaryote cell ? Mention which one of them transcribes hnRNA.

(ii) Write the changes that hnRNA undergoes before it leaves the nucleus as mRNA.

3

**OR**

(b) The length of DNA in any cell is far greater than the dimension of its nucleus. Explain how this enormous DNA is packaged in a eukaryotic cell.

3

27. Expand and explain the following techniques used in the 'Test Tube Baby' programme :

3

(a) GIFT

(b) ZIFT

(c) IUI

28. Trace the journey of a zygote from the isthmus of the fallopian tube up to its implantation in the uterus of a human female. Highlight the changes the zygote undergoes during the course of its journey up to implantation.

3

### SECTION D

The following questions are case-based questions. Read the cases carefully and answer the questions that follow.

29. The following pedigree chart shows the inheritance of a genetic disorder up to three generations of a family. Observe the chart and answer the questions that follow.

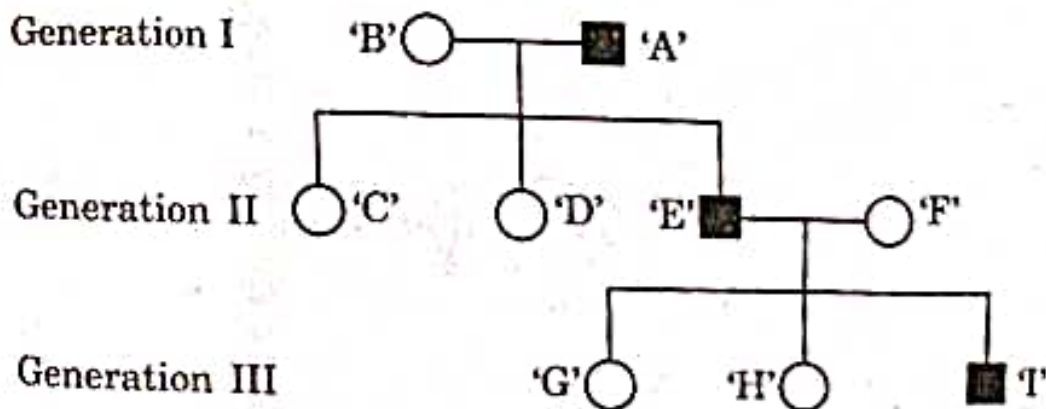

(i) Is the disease sex-linked or autosomal as per the chart ? Give reasons in support of your answer.

1



- (ii) Is it a recessive or a dominant disorder? 1
- (iii) Write the genotypes of the individuals 'C', 'D' and 'H'. 1
- (iv) (a) If the female 'D' marries a normal man, what will be the probability of their daughter being a sufferer of this disease? 1

OR

- (iv) (b) If the mother 'B' is a carrier of the disease, what will be the probability of their daughter being a sufferer of this disease? 1

30. The diagram shows the life cycle of a pathogenic protozoan.

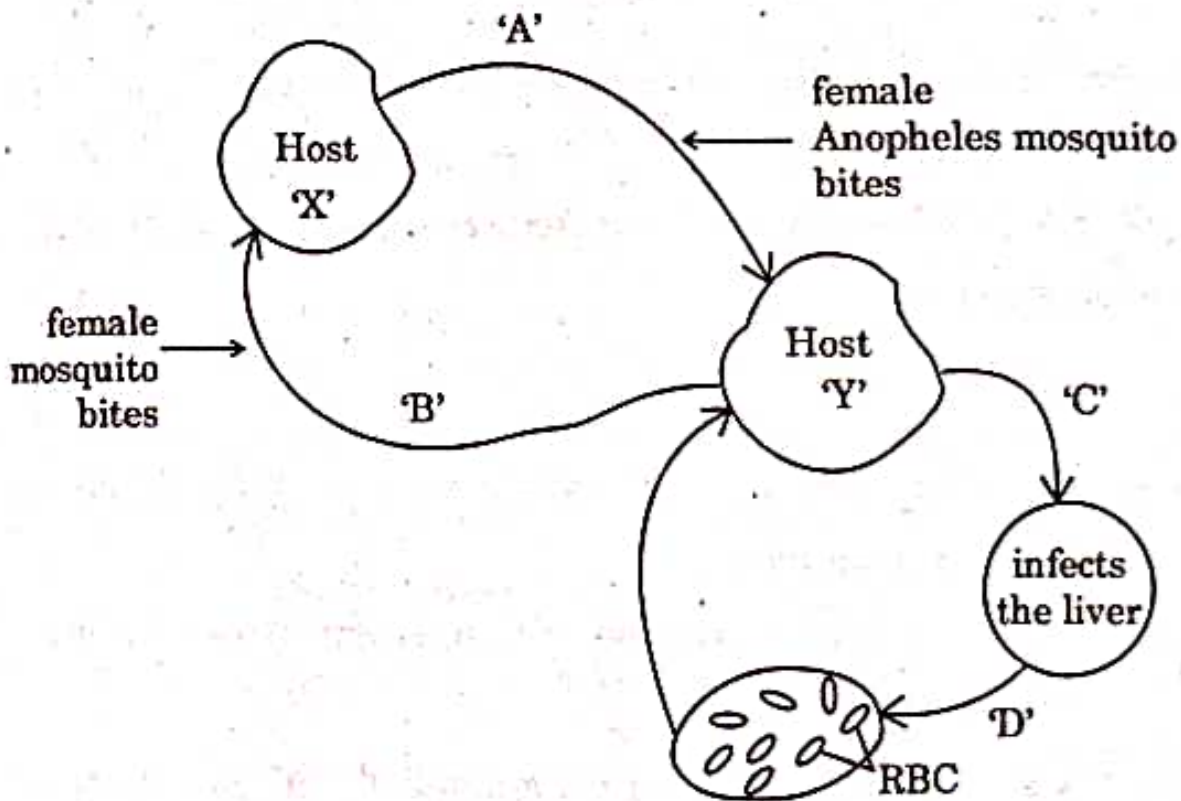

- (i) Name the parasitic stage that is being transferred from host 'X' to host 'Y'. 1
- (ii) Write the changes the parasite undergoes in the liver. 1

- (iii) Write the changes the parasite undergoes when it enters the RBC. 1
- (iv) (a) Trace the changes the parasite undergoes when the host 'X' takes its blood meal from infected host 'Y'. 1

OR

- (iv) (b) At which stage during the life cycle of the pathogen does the host 'Y' experience the symptoms of the disease? Name the disease and the toxic substance responsible for these symptoms. 1

### SECTION E

31. (a) Protein synthesis requires the services of all three types of RNAs, namely t-RNA, m-RNA and r-RNA. Explain the role of each of them during the process of protein synthesis in prokaryotes. 5

OR

- (b) A homozygous tall pea plant with green seeds is crossed with a homozygous dwarf pea plant with yellow seeds. T148

- (i) Write the possible phenotype and genotype of  $F_1$  generation.
- (ii) State the laws of Mendel that are proved true by the  $F_1$  generation.
- (iii) Mention the  $F_2$  phenotypic ratio along with their possible phenotypes.
- (iv) Write the genotypes of the male and female gametes produced by  $F_1$  progeny. 5

(a) Answer the following questions with respect to recombinant DNA technology :

5

- (i) Why is plasmid considered to be an important tool in rDNA technology ? From where can plasmids be isolated ? (Any two sources)
- (ii) Explain the role of 'ori' and selectable marker in a cloning vector.
- (iii) "r-DNA technology cannot proceed without restriction endonuclease." Justify.

**OR**

(b) Answer the following questions based on Bt-crops :

5

- (i) Why do farmers prefer to grow Bt cotton crop than genetically unmodified cotton crops ?
- (ii) Name any two insects that are killed by Bt toxin.
- (iii) Explain the mechanism by which Bt toxin kills the insects but not the bacterium which possesses the toxin.

33. (a) (i) Describe the arrangement of nuclei and cells in a mature embryo sac of a typical angiosperm.

(ii) Explain the devices the flowering plants have developed to prevent the following types of pollination :

- (1) Prevents both autogamy and geitonogamy
- (2) Prevents autogamy, but not geitonogamy

5

**OR**

P.T.O.





(b) (i) Write the specific location of the following in the testis in humans :

(1) Sertoli cells

(2) Leydig cells

(ii) Explain the coordination between Gonadotropins, Leydig cells and Sertoli cells and their role in spermatogenesis.

5