

# PHYSICS

## SECTION-A

1. Two objects of mass 10 kg and 20 kg respectively are connected to the two ends of a rigid rod of length 10 m with negligible mass. The distance of the center of mass of the system from the 10 kg mass is

- (1) 5 m (2)  $\frac{10}{3}$  m  
(3)  $\frac{20}{3}$  m (4) 10 m

**Answer (3)**

2. Match List-I with List-II

	List-I (Electromagnetic waves)		List-II (Wavelength)
(a)	AM radio waves	(i)	$10^{-10}$ m
(b)	Microwaves	(ii)	$10^2$ m
(c)	Infrared radiations	(iii)	$10^{-2}$ m
(d)	X-rays	(iv)	$10^{-4}$ m

Choose the correct answer from the options given below

- (1) (a) - (ii), (b) - (iii), (c) - (iv), (d) - (i)  
(2) (a) - (iv), (b) - (iii), (c) - (ii), (d) - (i)  
(3) (a) - (iii), (b) - (ii), (c) - (i), (d) - (iv)  
(4) (a) - (iii), (b) - (iv), (c) - (ii), (d) - (i)

**Answer (1)**

3. The energy that will be ideally radiated by a 100 kW transmitter in 1 hour is

- (1)  $1 \times 10^5$  J (2)  $36 \times 10^7$  J  
(3)  $36 \times 10^4$  J (4)  $36 \times 10^5$  J

**Answer (2)**

4. An ideal gas undergoes four different processes from the same initial state as shown in the figure below. Those processes are adiabatic, isothermal, isobaric and isochoric. The curve which represents the adiabatic process among 1, 2, 3 and 4 is

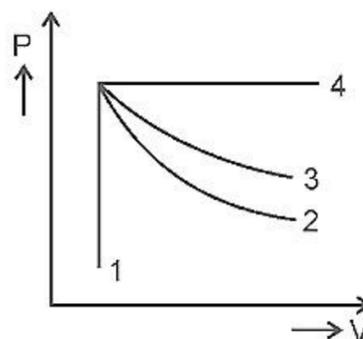

- (1) 4 (2) 1  
(3) 2 (4) 3

**Answer (3)**

5. Plane angle and solid angle have
- |                               |                                |
|-------------------------------|--------------------------------|
| (1) Both units and dimensions | (2) Units but no dimensions    |
| (3) Dimensions but no units   | (4) No units and no dimensions |

**Answer (2)**

6. In half wave rectification, if the input frequency is 60 Hz, then the output frequency would be
- |            |           |
|------------|-----------|
| (1) 120 Hz | (2) Zero  |
| (3) 30 Hz  | (4) 60 Hz |

**Answer (4)**

7. When two monochromatic lights of frequency,  $\nu$  and  $\frac{\nu}{2}$  are incident on a photoelectric metal, their stopping potential becomes  $\frac{V_s}{2}$  and  $V_s$  respectively. The threshold frequency for this metal is

- |                      |                      |
|----------------------|----------------------|
| (1) $\frac{3}{2}\nu$ | (2) $2\nu$           |
| (3) $3\nu$           | (4) $\frac{2}{3}\nu$ |

**Answer (1\*)**

8. The displacement-time graphs of two moving particles make angles of  $30^\circ$  and  $45^\circ$  with the x-axis as shown in the figure. The ratio of their respective velocity is

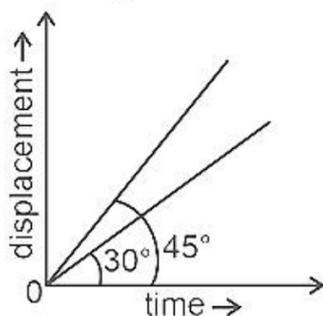

- |                    |                    |
|--------------------|--------------------|
| (1) $1 : \sqrt{3}$ | (2) $\sqrt{3} : 1$ |
| (3) $1 : 1$        | (4) $1 : 2$        |

**Answer (1)**

9. The dimensions  $[MLT^{-2}A^{-2}]$  belong to the
- |                           |                           |
|---------------------------|---------------------------|
| (1) Electric permittivity | (2) Magnetic flux         |
| (3) Self inductance       | (4) Magnetic permeability |

**Answer (4)**

10. The peak voltage of the ac source is equal to
- |   |   |
|---|---|
| (1) $1/\sqrt{2}$ times the rms value of the ac source | (2) The value of voltage supplied to the circuit    |
| (3) The rms value of the ac source                    | (4) $\sqrt{2}$ times the rms value of the ac source |

**Answer (4)**

11. The ratio of the distances travelled by a freely falling body in the 1<sup>st</sup>, 2<sup>nd</sup>, 3<sup>rd</sup> and 4<sup>th</sup> second
- |                      |                     |
|----------------------|---------------------|
| (1) $1 : 1 : 1 : 1$  | (2) $1 : 2 : 3 : 4$ |
| (3) $1 : 4 : 9 : 16$ | (4) $1 : 3 : 5 : 7$ |

**Answer (4)**

12. A body of mass 60 g experiences a gravitational force of 3.0 N, when placed at a particular point. The magnitude of the gravitational field intensity at that point is
- (1) 180 N/kg
  - (2) 0.05 N/kg
  - (3) 50 N/kg
  - (4) 20 N/kg

**Answer (3)**

13. In the given nuclear reaction, the element X is

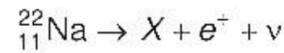

- |                             |                             |
|-----------------------------|-----------------------------|
| (1) ${}_{12}^{22}\text{Mg}$ | (2) ${}_{11}^{23}\text{Na}$ |
| (3) ${}_{10}^{23}\text{Ne}$ | (4) ${}_{10}^{22}\text{Ne}$ |

**Answer (4)**

14. If a soap bubble expands, the pressure inside the bubble

- |  |                      |
|--|----------------------|
| (1) Is equal to the atmospheric pressure | (2) Decreases        |
| (3) Increases                            | (4) Remains the same |

**Answer (2)**

15. Two resistors of resistance, 100  $\Omega$  and 200  $\Omega$  are connected in parallel in an electrical circuit. The ratio of the thermal energy developed in 100  $\Omega$  to that in 200  $\Omega$  in a given time is

- |           |           |
|-----------|-----------|
| (1) 4 : 1 | (2) 1 : 2 |
| (3) 2 : 1 | (4) 1 : 4 |

**Answer (3)**

16. Two hollow conducting spheres of radii  $R_1$  and  $R_2$  ( $R_1 \gg R_2$ ) have equal charges. The potential would be

- (1) Dependent on the material property of the sphere
- (2) More on bigger sphere
- (3) More on smaller sphere
- (4) Equal on both the spheres

**Answer (3)**

17. The angular speed of a fly wheel moving with uniform angular acceleration changes from 1200 rpm to 3120 rpm in 16 seconds. The angular acceleration in  $\text{rad/s}^2$  is

- |              |             |
|--------------|-------------|
| (1) $104\pi$ | (2) $2\pi$  |
| (3) $4\pi$   | (4) $12\pi$ |

**Answer (3)**

18. When light propagates through a material medium of relative permittivity  $\epsilon_r$  and relative permeability  $\mu_r$ , the velocity of light,  $v$  is given by ( $c$ -velocity of light in vacuum)

- |   |   |
|---|---|
| (1) $v = \frac{c}{\sqrt{\epsilon_r \mu_r}}$ | (2) $v = c$                               |
| (3) $v = \sqrt{\frac{\mu_r}{\epsilon_r}}$   | (4) $v = \sqrt{\frac{\epsilon_r}{\mu_r}}$ |

**Answer (1)**

19. A long solenoid of radius 1 mm has 100 turns per mm. If 1 A current flows in the solenoid, the magnetic field strength at the centre of the solenoid is
- (1)  $6.28 \times 10^{-4}$  T (2)  $6.28 \times 10^{-2}$  T  
(3)  $12.56 \times 10^{-2}$  T (4)  $12.56 \times 10^{-4}$  T

**Answer (3)**

20. A shell of mass  $m$  is at rest initially. It explodes into three fragments having mass in the ratio 2 : 2 : 1. If the fragments having equal mass fly off along mutually perpendicular directions with speed  $v$ , the speed of the third (lighter) fragment is
- (1)  $3\sqrt{2}v$  (2)  $v$   
(3)  $\sqrt{2}v$  (4)  $2\sqrt{2}v$

**Answer (4)**

21. As the temperature increases, the electrical resistance
- (1) Decreases for conductors but increases for semiconductors  
(2) Increases for both conductors and semiconductors  
(3) Decreases for both conductors and semiconductors  
(4) Increases for conductors but decreases for semiconductors

**Answer (4)**

22. A biconvex lens has radii of curvature, 20 cm each. If the refractive index of the material of the lens is 1.5, the power of the lens is
- (1) Infinity (2) +2 D  
(3) +20 D (4) +5 D

**Answer (4)**

23. Given below are two statements

**Statement I :** Biot-Savart's law gives us the expression for the magnetic field strength of an infinitesimal current element ( $Idl$ ) of a current carrying conductor only.

**Statement II :** Biot-Savart's law is analogous to Coulomb's inverse square law of charge  $q$ , with the former being related to the field produced by a scalar source,  $Idl$  while the latter being produced by a vector source,  $q$ .

In light of above statements choose the most appropriate answer from the options given below

- (1) Statement I is incorrect and Statement II is correct  
(2) Both Statement I and Statement II are correct  
(3) Both Statement I and Statement II are incorrect  
(4) Statement I is correct and Statement II is incorrect

**Answer (4)**

24. A square loop of side 1 m and resistance  $1 \Omega$  is placed in a magnetic field of 0.5 T. If the plane of loop is perpendicular to the direction of magnetic field, the magnetic flux through the loop is
- (1) Zero weber (2) 2 weber  
(3) 0.5 weber (4) 1 weber

**Answer (3)**

25. An electric lift with a maximum load of 2000 kg (lift + passengers) is moving up with a constant speed of  $1.5 \text{ ms}^{-1}$ . The frictional force opposing the motion is 3000 N. The minimum power delivered by the motor to the lift in watts is : ( $g = 10 \text{ m s}^{-2}$ )
- (1) 23500 (2) 23000  
(3) 20000 (4) 34500

**Answer (4)**

26. A light ray falls on a glass surface of refractive index  $\sqrt{3}$ , at an angle  $60^\circ$ . The angle between the refracted and reflected rays would be
- (1)  $120^\circ$  (2)  $30^\circ$   
 (3)  $60^\circ$  (4)  $90^\circ$

**Answer (4)**

27. A copper wire of length 10 m and radius  $\left(\frac{10^{-2}}{\sqrt{\pi}}\right)$  m has electrical resistance of  $10 \Omega$ . The current density in the wire for an electric field strength of 10 (V/m) is
- (1)  $10^5 \text{ A/m}^2$  (2)  $10^4 \text{ A/m}^2$   
 (3)  $10^6 \text{ A/m}^2$  (4)  $10^{-5} \text{ A/m}^2$

**Answer (1)**

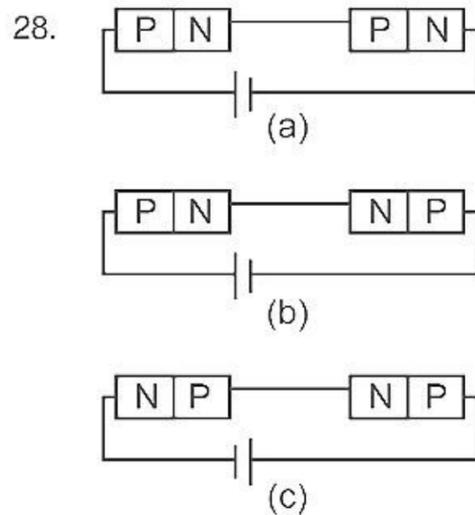

In the given circuits (a), (b) and (c), the potential drop across the two *p-n* junctions are equal in

- (1) Both circuits (a) and (c) (2) Circuit (a) only  
 (3) Circuit (b) only (4) Circuit (c) only
29. If the initial tension on a stretched string is doubled, then the ratio of the initial and final speeds of a transverse wave along the string is
- (1) 1 : 2 (2) 1 : 1  
 (3)  $\sqrt{2} : 1$  (4)  $1 : \sqrt{2}$

**Answer (4)**

30. The ratio of the radius of gyration of a thin uniform disc about an axis passing through its centre and normal to its plane to the radius of gyration of the disc about its diameter is
- (1)  $1 : \sqrt{2}$  (2) 2 : 1  
 (3)  $\sqrt{2} : 1$  (4) 4 : 1

**Answer (3)**

31. In a Young's double slit experiment, a student observes 8 fringes in a certain segment of screen when a monochromatic light of 600 nm wavelength is used. If the wavelength of light is changed to 400 nm, then the number of fringes he would observe in the same region of the screen is
- (1) 12 (2) 6  
 (3) 8 (4) 9

**Answer (1)**

32. The angle between the electric lines of force and the equipotential surface is

- (1)  $180^\circ$  (2)  $0^\circ$   
 (3)  $45^\circ$  (4)  $90^\circ$

**Answer (4)**

33. A spherical ball is dropped in a long column of a highly viscous liquid. The curve in the graph shown, which represents the speed of the ball ( $v$ ) as a function of time ( $t$ ) is

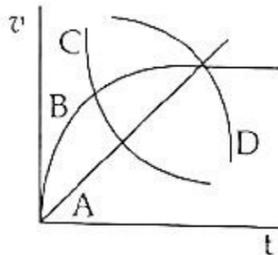

- (1) D (2) A  
 (3) B (4) C

**Answer (3)**

34. Let  $T_1$  and  $T_2$  be the energy of an electron in the first and second excited states of hydrogen atoms, respectively. According to the Bohr's model of an atom, the ratio  $T_1 : T_2$  is

- (1) 9 : 4 (2) 1 : 4  
 (3) 4 : 1 (4) 4 : 9

**Answer (1)**

35. The graph which shows the variation of the de Broglie wavelength ( $\lambda$ ) of a particle and its associated momentum ( $p$ ) is

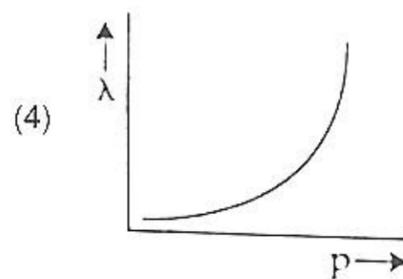
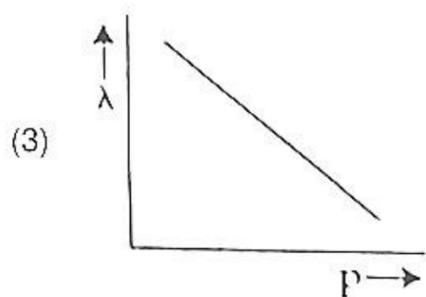
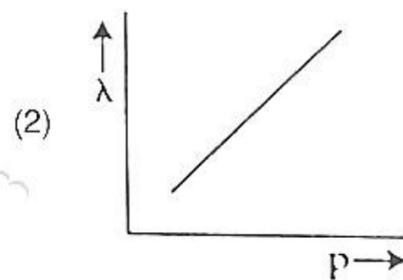
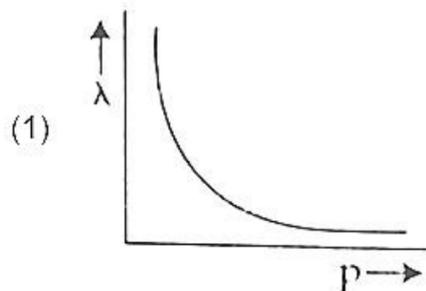

**Answer (1)**

### SECTION-B

36. Two pendulums of length 121 cm and 100 cm start vibrating in phase. At some instant, the two are at their mean position in the same phase. The minimum number of vibrations of the shorter pendulum after which the two are again in phase at the mean position is:

- (1) 8 (2) 11  
 (3) 9 (4) 10

**Answer (2)**

37. The volume occupied by the molecules contained in 4.5 kg water at STP, if the intermolecular forces vanish away is
- (1)  $5.6 \text{ m}^3$  (2)  $5.6 \times 10^6 \text{ m}^3$   
 (3)  $5.6 \times 10^3 \text{ m}^3$  (4)  $5.6 \times 10^{-3} \text{ m}^3$

**Answer (1)**

38. A nucleus of mass number 189 splits into two nuclei having mass number 125 and 64. The ratio of radius of two daughter nuclei respectively is
- (1) 25 : 16  
 (2) 1 : 1  
 (3) 4 : 5  
 (4) 5 : 4

**Answer (4)**

39. Given below are two statements : One is labelled as **Assertion (A)** and the other is labelled as **Reason (R)**.  
**Assertion (A):** The stretching of a spring is determined by the shear modulus of the material of the spring.  
**Reason (R):** A coil spring of copper has more tensile strength than a steel spring of same dimensions.  
 In the light of the above statements, choose the **most appropriate** answer from the options given below

- (1) **(A)** is false but **(R)** is true  
 (2) Both **(A)** and **(R)** are true and **(R)** is the correct explanation of **(A)**  
 (3) Both **(A)** and **(R)** are true and **(R)** is not the correct explanation of **(A)**  
 (4) **(A)** is true but **(R)** is false

**Answer (4)**

40. A capacitor of capacitance  $C = 900 \text{ pF}$  is charged fully by 100 V battery  $B$  as shown in figure (a). Then it is disconnected from the battery and connected to another uncharged capacitor of capacitance  $C = 900 \text{ pF}$  as shown in figure (b). The electrostatic energy stored by the system (b) is

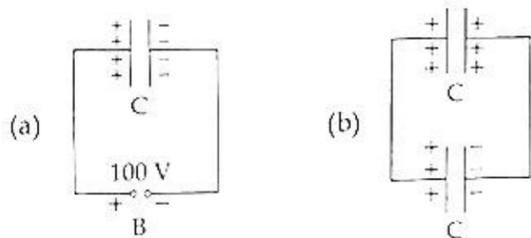

- (1)  $1.5 \times 10^{-6} \text{ J}$  (2)  $4.5 \times 10^{-6} \text{ J}$   
 (3)  $3.25 \times 10^{-6} \text{ J}$  (4)  $2.25 \times 10^{-6} \text{ J}$

**Answer (4)**

41. From Ampere's circuital law for a long straight wire of circular cross-section carrying a steady current, the variation of magnetic field in the inside and outside region of the wire is
- (1) A linearly decreasing function of distance upto the boundary of the wire and then a linearly increasing one for the outside region.  
 (2) Uniform and remains constant for both the regions.  
 (3) A linearly increasing function of distance upto the boundary of the wire and then linearly decreasing for the outside region.  
 (4) A linearly increasing function of distance  $r$  upto the boundary of the wire and then decreasing one with  $\frac{1}{r}$  dependence for the outside region.

**Answer (4)**

42. The area of a rectangular field (in  $\text{m}^2$ ) of length 55.3 m and breadth 25 m after rounding off the value for correct significant digits is
- (1)  $14 \times 10^2$  (2)  $138 \times 10^1$   
 (3) 1382 (4) 1382.5

**Answer (1)**

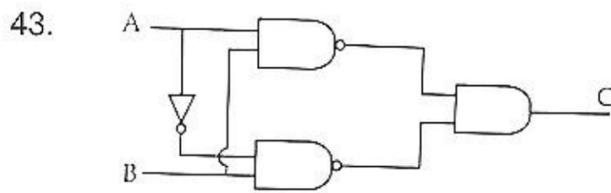

The truth table for the given logic circuit is

A	B	C
0	0	0
0	1	1
1	0	0
1	1	1

A	B	C
0	0	0
0	1	1
1	0	1
1	1	0

A	B	C
0	0	1
0	1	0
1	0	0
1	1	1

A	B	C
0	0	1
0	1	0
1	0	1
1	1	0

**Answer (4)**

44. Two transparent media A and B are separated by a plane boundary. The speed of light in those media are  $1.5 \times 10^8 \text{ m/s}$  and  $2.0 \times 10^8 \text{ m/s}$ , respectively. The critical angle for a ray of light for these two media is
- (1)  $\tan^{-1}(0.750)$  (2)  $\sin^{-1}(0.500)$   
 (3)  $\sin^{-1}(0.750)$  (4)  $\tan^{-1}(0.500)$

**Answer (3)**

45. A big circular coil of 1000 turns and average radius 10 m is rotating about its horizontal diameter at  $2 \text{ rad s}^{-1}$ . If the vertical component of earth's magnetic field at that place is  $2 \times 10^{-5} \text{ T}$  and electrical resistance of the coil is  $12.56 \Omega$ , then the maximum induced current in the coil will be
- (1) 2 A (2) 0.25 A  
 (3) 1.5 A (4) 1 A

**Answer (4)**

46. A wheatstone bridge is used to determine the value of unknown resistance X by adjusting the variable resistance Y as shown in the figure. For the most precise measurement of X, the resistances P and Q

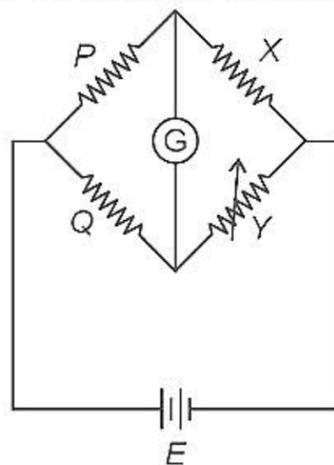

- (1) Do not play any significant role (2) Should be approximately equal to  $2X$   
 (3) Should be approximately equal and are small (4) Should be very large and unequal

**Answer (3)**

47. Two point charges  $-q$  and  $+q$  are placed at a distance of  $L$ , as shown in the figure.

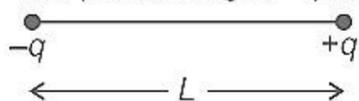

The magnitude of electric field intensity at a distance  $R (R \gg L)$  varies as:

- (1)  $\frac{1}{R^6}$  (2)  $\frac{1}{R^2}$   
 (3)  $\frac{1}{R^3}$  (4)  $\frac{1}{R^4}$

**Answer (3)**

48. Match List-I with List-II

	List-I		List-II
(a)	Gravitational constant (G)	(i)	$[L^2T^{-2}]$
(b)	Gravitational potential energy	(ii)	$[M^{-1}L^3T^{-2}]$
(c)	Gravitational potential	(iii)	$[LT^{-2}]$
(d)	Gravitational intensity	(iv)	$[ML^2T^{-2}]$

Choose the correct answer from the options given below

- (1) (a) - (iv), (b) - (ii), (c) - (i), (d) - (iii) (2) (a) - (ii), (b) - (i), (c) - (iv), (d) - (iii)  
 (3) (a) - (ii), (b) - (iv), (c) - (i), (d) - (iii) (4) (a) - (ii), (b) - (iv), (c) - (iii), (d) - (i)

**Answer (3)**

49. A series LCR circuit with inductance  $10\text{ H}$ , capacitance  $10\ \mu\text{F}$ , resistance  $50\ \Omega$  is connected to an ac source of voltage,  $V = 200\sin(100t)$  volt. If the resonant frequency of the LCR circuit is  $\nu_0$  and the frequency of the ac source is  $\nu$ , then

- (1)  $\nu = 100\text{ Hz}$ ;  $\nu_0 = \frac{100}{\pi}\text{ Hz}$   
 (2)  $\nu_0 = \nu = 50\text{ Hz}$   
 (3)  $\nu_0 = \nu = \frac{50}{\pi}\text{ Hz}$   
 (4)  $\nu_0 = \frac{50}{\pi}\text{ Hz}$ ,  $\nu = 50\text{ Hz}$

**Answer (3)**

50. A ball is projected with a velocity,  $10\text{ ms}^{-1}$ , at an angle of  $60^\circ$  with the vertical direction. Its speed at the highest point of its trajectory will be

- (1)  $10\text{ ms}^{-1}$   
 (2) Zero  
 (3)  $5\sqrt{3}\text{ ms}^{-1}$   
 (4)  $5\text{ ms}^{-1}$

**Answer (3)**