

DATE : 05/05/2024

Test Booklet Code



T1
DUGRI

Corporate Office : Aakash Tower, 8, Pusa Road, New Delhi-110005 | Ph.: 011-47623456s

Questions & Answers

Time : 3 hrs. 20 Min.

for

M.M. : 720

NEET (UG)-2024

Important Instructions :

- The test is of **3 hours 20 minutes** duration and the Test Booklet contains **200** multiple-choice questions (four options with a single correct answer) from **Physics, Chemistry and Biology (Botany and Zoology)**. 50 questions in each subject are divided into **two Sections (A and B)** as per details given below:
 - Section-A** shall consist of **35 (Thirty-five)** Questions in each subject (Question Nos-1 to 35, 51 to 85, 101 to 135 and 151 to 185). All Questions are compulsory.
 - Section-B** shall consist of **15 (Fifteen)** questions in each subject (Question Nos- 36 to 50, 86 to 100, 136 to 150 and 186 to 200). In **Section B**, a candidate needs to **attempt any 10 (Ten)** questions out of **15 (Fifteen)** in each subject.

Candidates are advised to read all 15 questions in each subject of Section B before they start attempting the question paper. In the event of a candidate attempting more than ten questions, **the first ten questions answered by the candidate shall be evaluated.**
- Each question carries **4 marks**. For each correct response, the candidate will get **4 marks**. For each incorrect response, **one mark** will be deducted from the total scores. **The maximum marks are 720.**
- Use **Blue / Black Ball Point Pen only** for writing particulars on this page / marking responses on Answer Sheet.
- Rough work is to be done in the space provided for this purpose in the Test Booklet only.
- On completion of the test, the candidate must **hand over the Answer Sheet (ORIGINAL and OFFICE copy) to the invigilator** before leaving the Room / Hall. The candidates are allowed to take away this Test Booklet with them.
- The CODE for this Booklet is T1. Make sure that the CODE printed on the Original Copy of the Answer Sheet is the same as that on this Test Booklet.** In case of discrepancy, the candidate should immediately report the matter to the Invigilator for replacement of both the Test Booklet and the Answer sheet.
- The candidates should ensure that the Answer Sheet is not folded. Do not make any stray marks on the Answer Sheet. Do not write your Roll No. anywhere else except in the specified space in the Test Booklet/Answer Sheet.
- Use of white fluid for correction is **NOT** permissible on the Answer Sheet.
- Each candidate must show on-demand his/her Admission Card to the Invigilator.
- No candidate, without special permission of the Centre Superintendent or Invigilator, would leave his/her seat.
- Use of Electronic/Manual Calculator is prohibited.
- The candidates are governed by all Rules and Regulations of the examination with regard to their conduct in the Examination Room / Hall. All cases of unfair means will be dealt with as per Rules and Regulations of this examination.
- No part of the Test Booklet and Answer Sheet shall be detached under any circumstances.**
- The candidates will write the Correct Test Booklet Code as given in the Test Booklet / Answer Sheet in the Attendance Sheet.

PHYSICS

SECTION-A

1. A wheel of a bullock cart is rolling on a level road as shown in the figure below. If its linear speed is v in the direction shown, which one of the following options is correct (P and Q are any highest and lowest points on the wheel, respectively)?

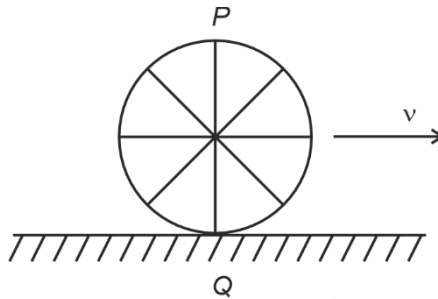

- (1) Both the points P and Q move with equal speed
- (2) Point P has zero speed
- (3) Point P moves slower than point Q
- (4) Point P moves faster than point Q

Answer (4)

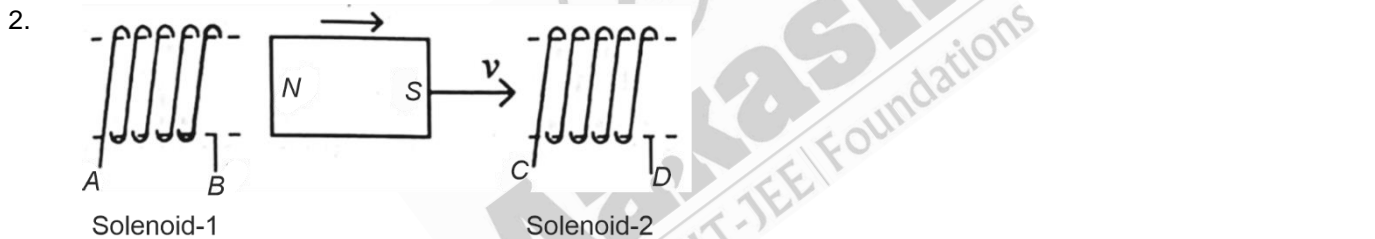

In the above diagram, a strong bar magnet is moving towards solenoid-2 from solenoid-1. The direction of induced current in solenoid-1 and that in solenoid-2, respectively, are through the directions:

- (1) AB and CD
- (2) BA and DC
- (3) AB and DC
- (4) BA and CD

Answer (3)

3. Consider the following statements A and B and identify the correct answer:

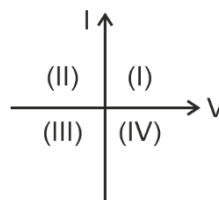

- A. For a solar-cell, the I - V characteristics lies in the IV quadrant of the given graph.
- B. In a reverse biased pn junction diode, the current measured in (μA), is due to majority charge carriers.

- (1) Both A and B are correct
- (2) Both A and B are incorrect
- (3) A is correct but B is incorrect
- (4) A is incorrect but B is correct

Answer (3)

4. A wire of length ' l ' and resistance 100Ω is divided into 10 equal parts. The first 5 parts are connected in series while the next 5 parts are connected in parallel. The two combinations are again connected in series. The resistance of this final combination is:

- (1) 55Ω (2) 60Ω
(3) 26Ω (4) 52Ω

Answer (4)

5. In the following circuit, the equivalent capacitance between terminal A and terminal B is :

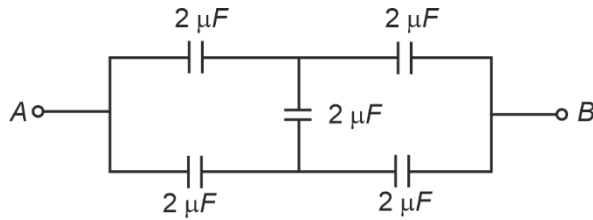

- (1) $0.5 \mu F$ (2) $4 \mu F$
(3) $2 \mu F$ (4) $1 \mu F$

Answer (3)

6. The output (Y) of the given logic gate is similar to the output of an/a

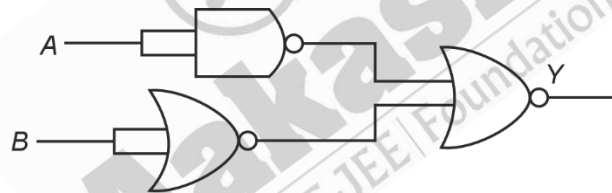

- (1) OR gate (2) AND gate
(3) NAND gate (4) NOR gate

Answer (2)

7. The terminal voltage of the battery, whose emf is $10 V$ and internal resistance 1Ω , when connected through an external resistance of 4Ω as shown in the figure is:

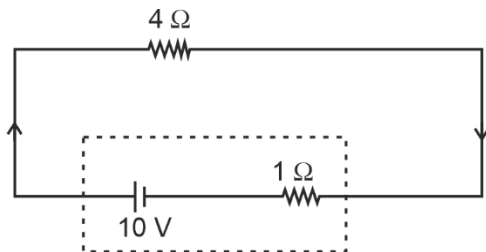

- (1) $8 V$ (2) $10 V$
(3) $4 V$ (4) $6 V$

Answer (1)

8. The mass of a planet is $\frac{1}{10}$ th that of the earth and its diameter is half that of the earth. The acceleration due to gravity on that planet is:

- (1) 4.9 m s^{-2} (2) 3.92 m s^{-2}
(3) 19.6 m s^{-2} (4) 9.8 m s^{-2}

Answer (2)

9. In a uniform magnetic field of 0.049 T, a magnetic needle performs 20 complete oscillations in 5 seconds as shown. The moment of inertia of the needle is $9.8 \times 10^{-6} \text{ kg m}^2$. If the magnitude of magnetic moment of the needle is $x \times 10^{-5} \text{ Am}^2$, then the value of 'x' is :

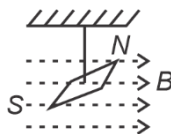

- (1) $50\pi^2$ (2) $1280\pi^2$
(3) $5\pi^2$ (4) $128\pi^2$

Answer (2)

10. If c is the velocity of light in free space, the correct statements about photon among the following are:

- A. The energy of a photon is $E = h\nu$.
B. The velocity of a photon is c .
C. The momentum of a photon, $p = \frac{h\nu}{c}$.
D. In a photon-electron collision, both total energy and total momentum are conserved.
E. Photon possesses positive charge.

Choose the correct answer from the options given below:

- (1) A, C and D only (2) A, B, D and E only
(3) A and B only (4) A, B, C and D only

Answer (4)

11. The maximum elongation of a steel wire of 1 m length if the elastic limit of steel and its Young's modulus, respectively, are $8 \times 10^8 \text{ N m}^{-2}$ and $2 \times 10^{11} \text{ N m}^{-2}$, is:

- (1) 40 mm (2) 8 mm
(3) 4 mm (4) 0.4 mm

Answer (3)

12. A logic circuit provides the output Y as per the following truth table :

A	B	Y
0	0	1
0	1	0
1	0	1
1	1	0

The expression for the output Y is :

- (1) \bar{B} (2) B
(3) $A.B + \bar{A}$ (4) $A.\bar{B} + \bar{A}$

Answer (1)

13. The moment of inertia of a thin rod about an axis passing through its mid point and perpendicular to the rod is 2400 g cm^2 . The length of the 400 g rod is nearly:
- (1) 20.7 cm
 - (2) 72.0 cm
 - (3) 8.5 cm
 - (4) 17.5 cm

Answer (3)

14. In a vernier callipers, $(N + 1)$ divisions of vernier scale coincide with N divisions of main scale. If 1 MSD represents 0.1 mm, the vernier constant (in cm) is:
- (1) $100N$
 - (2) $10(N + 1)$
 - (3) $\frac{1}{10N}$
 - (4) $\frac{1}{100(N + 1)}$

Answer (4)

15. Match List I with List II.

	List I (Spectral Lines of Hydrogen for transitions from)		List II (Wavelengths (nm))
A.	$n_2 = 3$ to $n_1 = 2$	I.	410.2
B.	$n_2 = 4$ to $n_1 = 2$	II.	434.1
C.	$n_2 = 5$ to $n_1 = 2$	III.	656.3
D.	$n_2 = 6$ to $n_1 = 2$	IV.	486.1

Choose the correct answer from the options given below:

- (1) A-IV, B-III, C-I, D-II
 - (2) A-I, B-II, C-III, D-IV
 - (3) A-II, B-I, C-IV, D-III
 - (4) A-III, B-IV, C-II, D-I
16. If the monochromatic source in Young's double slit experiment is replaced by white light, then
- (1) There will be a central bright white fringe surrounded by a few coloured fringes
 - (2) All bright fringes will be of equal width
 - (3) Interference pattern will disappear
 - (4) There will be a central dark fringe surrounded by a few coloured fringes

Answer (1)

17. The graph which shows the variation of $\left(\frac{1}{\lambda^2}\right)$ and its kinetic energy, E is (where λ is de Broglie wavelength of a free particle):

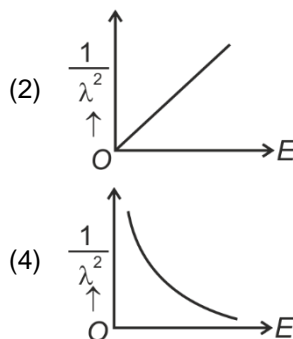
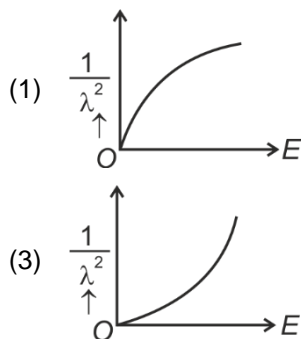

Answer (2)

18. Match List-I with List-II.

List-I (Material)	List-II (Susceptibility (χ))
A. Diamagnetic	I. $\chi = 0$
B. Ferromagnetic	II. $0 > \chi \geq -1$
C. Paramagnetic	III. $\chi \gg 1$
D. Non-magnetic	IV. $0 < \chi < \epsilon$ (a small positive number)

Choose the correct answer from the options given below

- (1) A-III, B-II, C-I, D-IV (2) A-IV, B-III, C-II, D-I
(3) A-II, B-III, C-IV, D-I (4) A-II, B-I, C-III, D-IV

Answer (3)

19. An unpolarised light beam strikes a glass surface at Brewster's angle. Then
- (1) Both the reflected and refracted light will be completely polarised.
 - (2) The reflected light will be completely polarised but the refracted light will be partially polarised.
 - (3) The reflected light will be partially polarised.
 - (4) The refracted light will be completely polarised.

Answer (2)

20. A particle moving with uniform speed in a circular path maintains:
- (1) Constant velocity but varying acceleration
 - (2) Varying velocity and varying acceleration
 - (3) Constant velocity
 - (4) Constant acceleration

Answer (2)

21. The quantities which have the same dimensions as those of solid angle are:
- (1) strain and arc
 - (2) angular speed and stress
 - (3) strain and angle
 - (4) stress and angle

Answer (3)

22. A bob is whirled in a horizontal plane by means of a string with an initial speed of ω rpm. The tension in the string is T . If speed becomes 2ω while keeping the same radius, the tension in the string becomes:

- (1) $\frac{T}{4}$ (2) $\sqrt{2}T$
 (3) T (4) $4T$

Answer (4)

23. If $x = 5 \sin\left(\pi t + \frac{\pi}{3}\right)$ m represents the motion of a particle executing simple harmonic motion, the amplitude and time period of motion, respectively, are

- (1) 5 cm, 1 s (2) 5 m, 1 s
 (3) 5 cm, 2 s (4) 5 m, 2 s

Answer (4)

24. A thermodynamic system is taken through the cycle $abcd$. The work done by the gas along the path bc is:

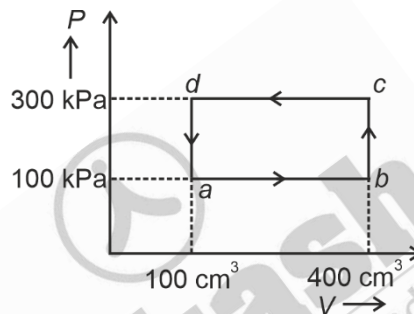

- (1) -90 J (2) -60 J
 (3) Zero (4) 30 J

Answer (3)

25. Given below are two statements:

Statement I: Atoms are electrically neutral as they contain equal number of positive and negative charges.

Statement II: Atoms of each element are stable and emit their characteristic spectrum.

In the light of the above statements, choose the *most appropriate* answer from the options given below.

- (1) Statement I is correct but Statement II is incorrect
 (2) Statement I is incorrect but Statement II is correct
 (3) Both Statement I and Statement II are correct
 (4) Both Statement I and Statement II are incorrect

Answer (1)

26. In an ideal transformer, the turns ratio is $\frac{N_P}{N_S} = \frac{1}{2}$. The ratio $V_S : V_P$ is equal to (the symbols carry their usual meaning) :

- (1) 1 : 1 (2) 1 : 4
 (3) 1 : 2 (4) 2 : 1

Answer (4)

27. Two bodies A and B of same mass undergo completely inelastic one dimensional collision. The body A moves with velocity v_1 while body B is at rest before collision. The velocity of the system after collision is v_2 . The ratio $v_1 : v_2$ is

- (1) 4 : 1 (2) 1 : 4
(3) 1 : 2 (4) 2 : 1

Answer (4)

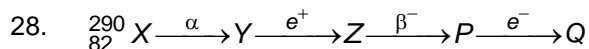

In the nuclear emission stated above, the mass number and atomic number of the product Q respectively, are

- (1) 288, 82 (2) 286, 81
(3) 280, 81 (4) 286, 80

Answer (2)

29. Given below are two statements: one is labelled as **Assertion A** and the other is labelled as **Reason R**.

Assertion A: The potential (V) at any axial point, at 2 m distance (r) from the centre of the dipole of dipole moment vector \vec{P} of magnitude, 4×10^{-6} C m, is $\pm 9 \times 10^3$ V.

(Take $\frac{1}{4\pi\epsilon_0} = 9 \times 10^9$ SI units)

Reason R: $V = \pm \frac{2P}{4\pi\epsilon_0 r^2}$, where r is the distance of any axial point, situated at 2 m from the centre of the dipole.

In the light of the above statements, choose the **correct** answer from the options given below:

- (1) A is true but R is false.
(2) A is false but R is true.
(3) Both A and R are true and R is the correct explanation of A.
(4) Both A and R are true and R is NOT the correct explanation of A.

Answer (1)

30. A thin spherical shell is charged by some source. The potential difference between the two points C and P (in V) shown in the figure is:

(Take $\frac{1}{4\pi\epsilon_0} = 9 \times 10^9$ SI units)

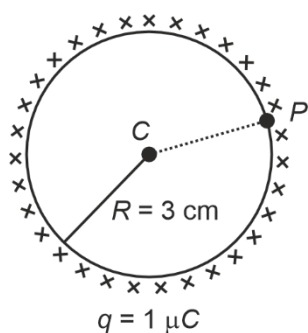

- (1) 0.5×10^5 (2) Zero
(3) 3×10^5 (4) 1×10^5

Answer (2)

31. A thin flat circular disc of radius 4.5 cm is placed gently over the surface of water. If surface tension of water is 0.07 N m^{-1} , then the excess force required to take it away from the surface is

- (1) 1.98 mN (2) 99 N
 (3) 19.8 mN (4) 198 N

Answer (3)

32. A light ray enters through a right angled prism at point P with the angle of incidence 30° as shown in figure. It travels through the prism parallel to its base BC and emerges along the face AC . The refractive index of the prism is:

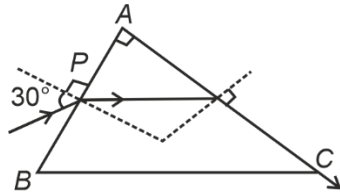

- (1) $\frac{\sqrt{3}}{4}$ (2) $\frac{\sqrt{3}}{2}$
 (3) $\frac{\sqrt{5}}{4}$ (4) $\frac{\sqrt{5}}{2}$

Answer (4)

33. At any instant of time t , the displacement of any particle is given by $2t - 1$ (SI unit) under the influence of force of 5 N. The value of instantaneous power is (in SI unit):

- (1) 7 (2) 6
 (3) 10 (4) 5

Answer (3)

34. A tightly wound 100 turns coil of radius 10 cm carries a current of 7 A. The magnitude of the magnetic field at the centre of the coil is (Take permeability of free space as $4\pi \times 10^{-7}$ SI units):

- (1) 4.4 mT (2) 44 T
 (3) 44 mT (4) 4.4 T

Answer (1)

35. A horizontal force 10 N is applied to a block A as shown in figure. The mass of blocks A and B are 2 kg and 3 kg respectively. The blocks slide over a frictionless surface. The force exerted by block A on block B is :

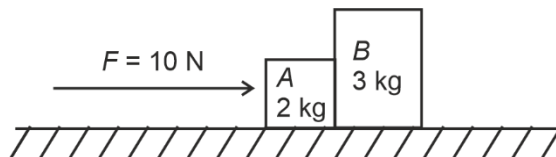

- (1) 6 N (2) 10 N
 (3) Zero (4) 4 N

Answer (1)

SECTION-B

36. A small telescope has an objective of focal length 140 cm and an eye piece of focal length 5.0 cm. The magnifying power of telescope for viewing a distant object is:

- (1) 17 (2) 32
(3) 34 (4) 28

Answer (4)

37. Two heaters A and B have power rating of 1 kW and 2 kW, respectively. Those two are first connected in series and then in parallel to a fixed power source. The ratio of power outputs for these two cases is:

- (1) 1 : 2
(2) 2 : 3
(3) 1 : 1
(4) 2 : 9

Answer (4)

38. If the mass of the bob in a simple pendulum is increased to thrice its original mass and its length is made half its original length, then the new time period of oscillation is $\frac{x}{2}$ times its original time period. Then the value of x is:

- (1) $2\sqrt{3}$ (2) 4
(3) $\sqrt{3}$ (4) $\sqrt{2}$

Answer (4)

39. A parallel plate capacitor is charged by connecting it to a battery through a resistor. If I is the current in the circuit, then in the gap between the plates:

- (1) Displacement current of magnitude equal to I flows in a direction opposite to that of I
(2) Displacement current of magnitude greater than I flows but can be in any direction
(3) There is no current
(4) Displacement current of magnitude equal to I flows in the same direction as I

Answer (4)

40. A metallic bar of Young's modulus, $0.5 \times 10^{11} \text{ N m}^{-2}$ and coefficient of linear thermal expansion $10^{-5} \text{ }^\circ\text{C}^{-1}$, length 1 m and area of cross-section 10^{-3} m^2 is heated from 0°C to 100°C without expansion or bending. The compressive force developed in it is :

- (1) $100 \times 10^3 \text{ N}$
(2) $2 \times 10^3 \text{ N}$
(3) $5 \times 10^3 \text{ N}$
(4) $50 \times 10^3 \text{ N}$

Answer (4)

44. Choose the correct circuit which can achieve the bridge balance.

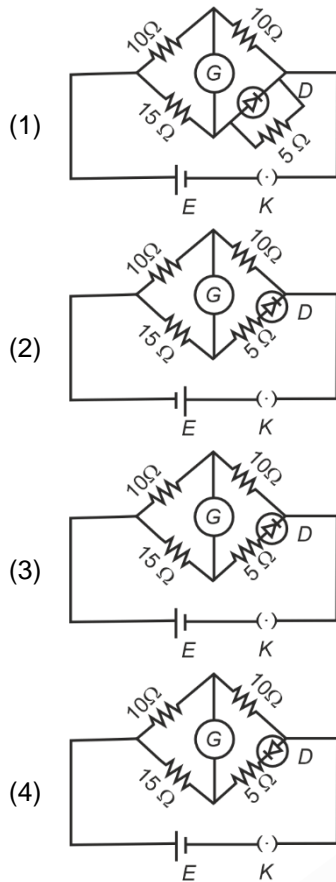

Answer (3)

45. The property which is not of an electromagnetic wave travelling in free space is that:

- (1) They travel with a speed equal to $\frac{1}{\sqrt{\mu_0 \epsilon_0}}$
- (2) They originate from charges moving with uniform speed
- (3) They are transverse in nature
- (4) The energy density in electric field is equal to energy density in magnetic field

Answer (2)

46. The minimum energy required to launch a satellite of mass m from the surface of earth of mass M and radius R in a circular orbit at an altitude of $2R$ from the surface of the earth is:

- (1) $\frac{GmM}{2R}$
- (2) $\frac{GmM}{3R}$
- (3) $\frac{5GmM}{6R}$
- (4) $\frac{2GmM}{3R}$

Answer (3)

CHEMISTRY

SECTION-A

51. Match List I with List II.

List-I

(Process)

- A. Isothermal process
- B. Isochoric process
- C. Isobaric process
- D. Adiabatic process

List-II

(Conditions)

- I. No heat exchange
- II. Carried out at constant temperature
- III. Carried out at constant volume
- IV. Carried out at constant pressure

Choose the correct answer from the options given below:

- (1) A-I, B-II, C-III, D-IV
- (2) A-II, B-III, C-IV, D-I
- (3) A-IV, B-III, C-II, D-I
- (4) A-IV, B-II, C-III, D-I

Answer (2)

52. Given below are two statements:

Statement I : The boiling point of three isomeric pentanes follows the order n-pentane > isopentane > neopentane

Statement II : When branching increases, the molecule attains a shape of sphere. This results in smaller surface area for contact, due to which the intermolecular forces between the spherical molecules are weak, thereby lowering the boiling point.

In the light of the above statements, choose the *most appropriate* answer from the options given below:

- (1) Statement I is correct but Statement II is incorrect
- (2) Statement I is incorrect but Statement II is correct
- (3) Both Statement I and Statement II are correct
- (4) Both Statement I and Statement II are incorrect

Answer (3)

53. Match List I with List II.

List I

(Molecule)

- A. ethane
- B. ethene
- C. carbon molecule, C₂
- D. ethyne

List II

(Number and types of bond/s between two carbon atoms)

- I. one σ -bond and two π -bonds
- II. two π -bonds
- III. one σ -bond
- IV. one σ -bond and one π -bond

Choose the correct answer from the options given below:

- (1) A-III, B-IV, C-II, D-I
- (2) A-III, B-IV, C-I, D-II
- (3) A-I, B-IV, C-II, D-III
- (4) A-IV, B-III, C-II, D-I

Answer (1)

54. Which one of the following alcohols reacts instantaneously with Lucas reagent?

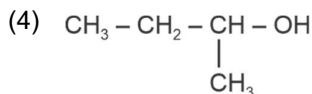
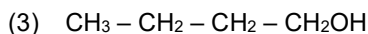
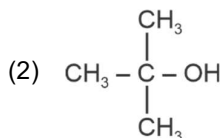
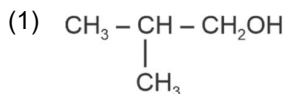

Answer (2)

55. Match List I with List II

- List I**
(Quantum Number)
- A. m_l
B. m_s
C. l
D. n

- List II**
(Information provided)
- I. Shape of orbital
II. Size of orbital
III. Orientation of orbital
IV. Orientation of spin of electron

Choose the correct answer from the options given below :

- (1) A-III, B-IV, C-II, D-I
(3) A-I, B-III, C-II, D-IV

- (2) A-II, B-I, C-IV, D-III
(4) A-III, B-IV, C-I, D-II

Answer (4)

56. 'Spin only' magnetic moment is same for which of the following ions?

- A. Ti^{3+}
C. Mn^{2+}
E. Sc^{3+}
B. Cr^{2+}
D. Fe^{2+}

Choose the most appropriate answer from the options given below.

- (1) B and C only
(3) B and D only
(2) A and D only
(4) A and E only

Answer (3)

57. On heating, some solid substances change from solid to vapour state without passing through liquid state. The technique used for the purification of such solid substances based on the above principle is known as

- (1) Distillation
(3) Crystallization
(2) Chromatography
(4) Sublimation

Answer (4)

58. The energy of an electron in the ground state ($n = 1$) for He^+ ion is $-x$ J, then that for an electron in $n = 2$ state for Be^{3+} ion in J is

- (1) $-4x$
(3) $-x$
(2) $-\frac{4}{9}x$
(4) $-\frac{x}{9}$

Answer (3)

59. Activation energy of any chemical reaction can be calculated if one knows the value of
- (1) orientation of reactant molecules during collision
 - (2) rate constant at two different temperatures
 - (3) rate constant at standard temperature
 - (4) probability of collision

Answer (2)

60. Which plot of $\ln k$ vs $\frac{1}{T}$ is consistent with Arrhenius equation?

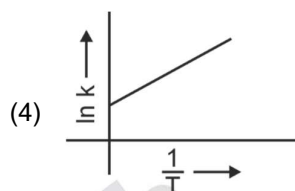
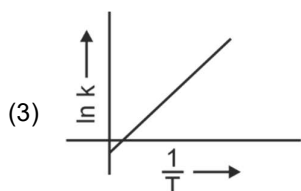
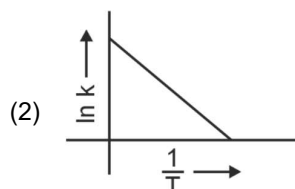
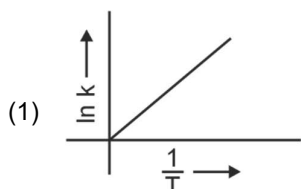

Answer (2)

61. Given below are two statements:

Statement I: The boiling point of hydrides of Group 16 elements follow the order $H_2O > H_2Te > H_2Se > H_2S$.

Statement II: On the basis of molecular mass, H_2O is expected to have lower boiling point than the other members of the group but due to the presence of extensive H-bonding in H_2O , it has higher boiling point.

In the light of the above statements, choose the correct answer from the options given below:

- (1) Statement I is true but Statement II is false
- (2) Statement I is false but Statement II is true
- (3) Both Statement I and Statement II are true
- (4) Both Statement I and Statement II are false

Answer (3)

62. The reagents with which glucose does **not** react to give the corresponding tests/products are

- A. Tollen's reagents
- B. Schiff's reagent
- C. HCN
- D. NH_2OH
- E. $NaHSO_3$

Choose the correct options from the given below:

- (1) B and E
- (2) E and D
- (3) B and C
- (4) A and D

Answer (1)

63. Arrange the following elements in increasing order of first ionization enthalpy:

Li, Be, B, C, N

Choose the correct answer from the options given below:

- (1) $Li < Be < C < B < N$
- (2) $Li < Be < N < B < C$
- (3) $Li < Be < B < C < N$
- (4) $Li < B < Be < C < N$

Answer (4)

64. Arrange the following elements in increasing order of electronegativity:

N, O, F, C, Si

Choose the correct answer from the options given below:

(1) $O < F < N < C < Si$

(2) $F < O < N < C < Si$

(3) $Si < C < N < O < F$

(4) $Si < C < O < N < F$

Answer (3)

65. The E° value for the Mn^{3+}/Mn^{2+} couple is more positive than that of Cr^{3+}/Cr^{2+} or Fe^{3+}/Fe^{2+} due to change of

(1) d^4 to d^5 configuration

(2) d^3 to d^5 configuration

(3) d^5 to d^4 configuration

(4) d^5 to d^2 configuration

Answer (1)

66. Match List I with List II.

List I

(Compound)

A. NH_3

B. BrF_5

C. XeF_4

D. SF_6

List II

(Shape/geometry)

I. Trigonal Pyramidal

II. Square Planar

III. Octahedral

IV. Square Pyramidal

Choose the correct answer from the options given below:

(1) A-III, B-IV, C-I, D-II

(2) A-II, B-III, C-IV, D-I

(3) A-I, B-IV, C-II, D-III

(4) A-II, B-IV, C-III, D-I

Answer (3)

67. Match List I with List II.

List I (Complex)

A. $[Co(NH_3)_5(NO_2)]Cl_4$

B. $[Co(NH_3)_5(SO_4)]Br$

C. $[Co(NH_3)_6][Cr(CN)_6]$

D. $[Co(H_2O)_6]Cl_3$

List II (Type of isomerism)

I. Solvate isomerism

II. Linkage isomerism

III. Ionization isomerism

IV. Coordination isomerism

Choose the correct answer from the options given below:

(1) A-I, B-IV, C-III, D-II

(2) A-II, B-IV, C-III, D-I

(3) A-II, B-III, C-IV, D-I

(4) A-I, B-III, C-IV, D-II

Answer (3)

68. Intramolecular hydrogen bonding is present in

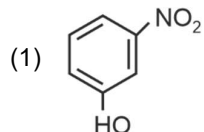

(2) HF

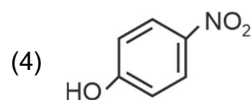
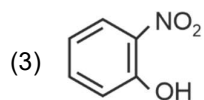

Answer (3)

69. Given below are two statements:

Statement I : Aniline does not undergo Friedel-Crafts alkylation reaction.

Statement II : Aniline cannot be prepared through Gabriel synthesis.

In the light of the above statements, choose the correct answer from the options given below:

- (1) Statement I is correct but Statement II is false
- (2) Statement I is incorrect but Statement II is true
- (3) Both statement I and Statement II are true
- (4) Both Statement I and Statement II are false

Answer (3)

70. The highest number of helium atoms is in

- (1) 4 g of helium
- (2) 2.271098 L of helium at STP
- (3) 4 mol of helium
- (4) 4 u of helium

Answer (3)

71. Match List I with List II.

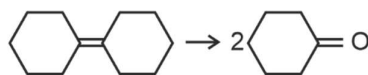
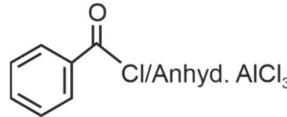
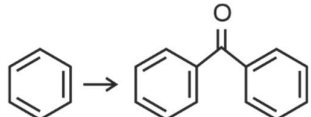
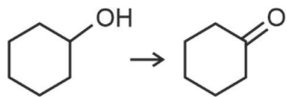
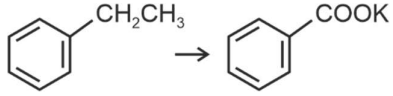
List I (Reaction)	List II (Reagents/Condition)
<p>A. </p>	<p>I. </p>
<p>B. </p>	<p>II. CrO₃</p>
<p>C. </p>	<p>III. KMnO₄/KOH, Δ</p>
<p>D. </p>	<p>IV. (i) O₃ (ii) Zn-H₂O</p>

Choose the correct answer from the options given below:

- (1) A-IV, B-I, C-II, D-III
- (2) A-I, B-IV, C-II, D-III
- (3) A-IV, B-I, C-III, D-II
- (4) A-III, B-I, C-II, D-IV

Answer (1)

72. Identify the correct reagents that would bring about the following transformation.

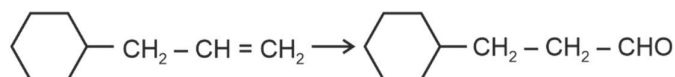

- (1) (i) BH₃
(ii) H₂O₂ / OH^\ominus
(iii) alk. KMnO₄
(iv) H₃O[⊕]
- (2) (i) H₂O/H⁺
(ii) PCC
- (3) (i) H₂O/H⁺
(ii) CrO₃
- (4) (i) BH₃
(ii) H₂O₂ / OH^\ominus
(iii) PCC

Answer (4)

73. The compound that will undergo S_N1 reaction with the fastest rate is

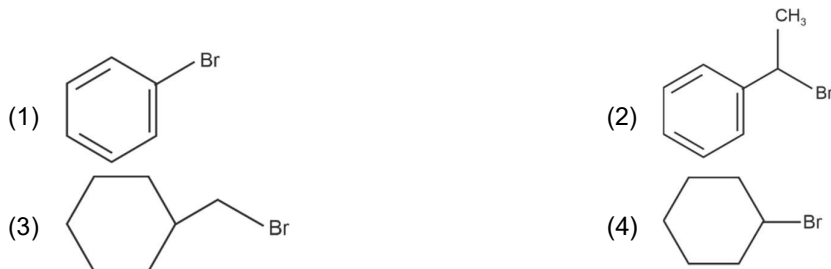

Answer (2)

74. Fehling's solution 'A' is

- (1) alkaline solution of sodium potassium tartrate (Rochelle's salt)
- (2) aqueous sodium citrate
- (3) aqueous copper sulphate
- (4) alkaline copper sulphate

Answer (3)

75. The most stable carbocation among the following is :



Answer (2)

76. For the reaction $2A \rightleftharpoons B + C$, $K_c = 4 \times 10^{-3}$. At a given time, the composition of reaction mixture is: $[A] = [B] = [C] = 2 \times 10^{-3}$ M.

Then, which of the following is correct?

- (1) Reaction has a tendency to go in backward direction.
- (2) Reaction has gone to completion in forward direction.
- (3) Reaction is at equilibrium.
- (4) Reaction has a tendency to go in forward direction.

Answer (1)

77. The Henry's law constant (K_H) values of three gases (A, B, C) in water are 145, 2×10^{-5} and 35 kbar, respectively. The solubility of these gases in water follow the order:

- (1) $A > C > B$
- (2) $A > B > C$
- (3) $B > A > C$
- (4) $B > C > A$

Answer (4)

78. A compound with a molecular formula of C_6H_{14} has two tertiary carbons. Its IUPAC name is :

- (1) 2,3-dimethylbutane
- (2) 2,2-dimethylbutane
- (3) n-hexane
- (4) 2-methylpentane

Answer (1)

79. In which of the following equilibria, K_p and K_c are **NOT** equal?

- (1) $\text{CO}_{(g)} + \text{H}_2\text{O}_{(g)} \rightleftharpoons \text{CO}_{2(g)} + \text{H}_{2(g)}$ (2) $2\text{BrCl}_{(g)} \rightleftharpoons \text{Br}_{2(g)} + \text{Cl}_{2(g)}$
 (3) $\text{PCl}_{5(g)} \rightleftharpoons \text{PCl}_{3(g)} + \text{Cl}_{2(g)}$ (4) $\text{H}_{2(g)} + \text{I}_{2(g)} \rightleftharpoons 2\text{HI}_{(g)}$

Answer (3)

80. Which reaction is **NOT** a redox reaction?

- (1) $\text{H}_2 + \text{Cl}_2 \rightarrow 2\text{HCl}$ (2) $\text{BaCl}_2 + \text{Na}_2\text{SO}_4 \rightarrow \text{BaSO}_4 + 2\text{NaCl}$
 (3) $\text{Zn} + \text{CuSO}_4 \rightarrow \text{ZnSO}_4 + \text{Cu}$ (4) $2\text{KClO}_3 + \text{I}_2 \rightarrow 2\text{KIO}_3 + \text{Cl}_2$

Answer (2)

81. Given below are two statements :

Statement I: Both $[\text{Co}(\text{NH}_3)_6]^{3+}$ and $[\text{CoF}_6]^{3-}$ complexes are octahedral but differ in their magnetic behaviour.

Statement II: $[\text{Co}(\text{NH}_3)_6]^{3+}$ is diamagnetic whereas $[\text{CoF}_6]^{3-}$ is paramagnetic.

In the light of the above statements, choose the correct answer from the options given below:

- (1) Statement I is true but Statement II is false (2) Statement I is false but Statement II is true
 (3) Both Statement I and Statement II are true (4) Both Statement I and Statement II are false

Answer (3)

82. 1 gram of sodium hydroxide was treated with 25 mL of 0.75 M HCl solution, the mass of sodium hydroxide left unreacted is equal to

- (1) Zero mg (2) 200 mg
 (3) 750 mg (4) 250 mg

Answer (4)

83. Among Group 16 elements, which one does **NOT** show -2 oxidation state?

- (1) Te (2) Po
 (3) O (4) Se

Answer (2)

84. In which of the following processes entropy increases?

- A. A liquid evaporates to vapour.
 B. Temperature of a crystalline solid lowered from 130 K to 0 K.
 C. $2\text{NaHCO}_{3(s)} \rightarrow \text{Na}_2\text{CO}_{3(s)} + \text{CO}_{2(g)} + \text{H}_2\text{O}_{(g)}$
 D. $\text{Cl}_{2(g)} \rightarrow 2\text{Cl}_{(g)}$

Choose the correct answer from the options given below:

- (1) A, C and D (2) C and D
 (3) A and C (4) A, B and D

Answer (1)

85. Match List I with List II.

List I (Conversion)	List II (Number of Faraday required)
A. 1 mol of H_2O to O_2	I. 3F
B. 1 mol of MnO_4^- to Mn^{2+}	II. 2F
C. 1.5 mol of Ca from molten CaCl_2	III. 1F
D. 1 mol of FeO to Fe_2O_3	IV. 5F

Choose the correct answer from the options given below:

- (1) A-II, B-III, C-I, D-IV
 (2) A-III, B-IV, C-II, D-I
 (3) A-II, B-IV, C-I, D-III
 (4) A-III, B-IV, C-I, D-II

Answer (3)

SECTION-B

86. Major products A and B formed in the following reaction sequence, are

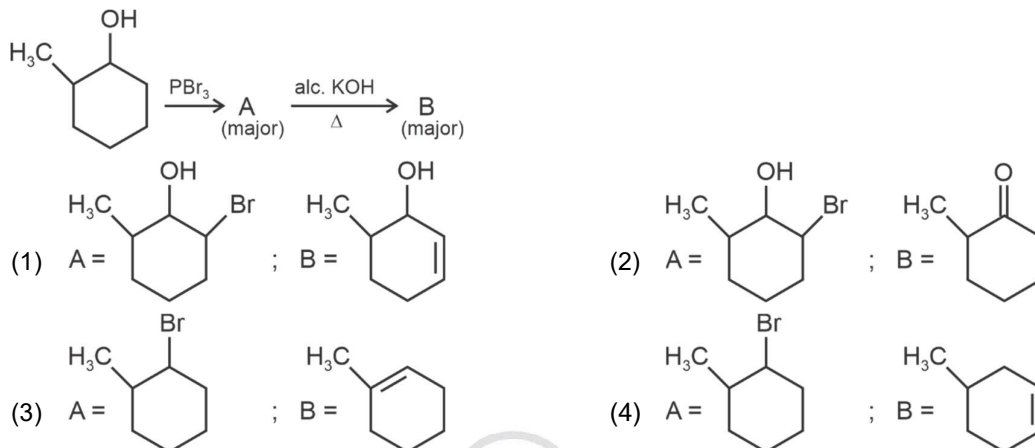

Answer (3)

87. Consider the following reaction in a sealed vessel at equilibrium with concentrations of $N_2 = 3.0 \times 10^{-3}$ M, $O_2 = 4.2 \times 10^{-3}$ M and $NO = 2.8 \times 10^{-3}$ M.

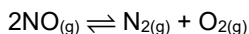

If 0.1 mol L^{-1} of $NO(g)$ is taken in a closed vessel, what will be degree of dissociation (α) of $NO(g)$ at equilibrium?

- (1) 0.8889
 (2) 0.717
 (3) 0.00889
 (4) 0.0889

Answer (2)

88. The products A and B obtained in the following reactions, respectively, are

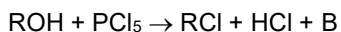
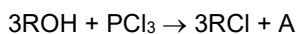

- (1) H_3PO_4 and $POCl_3$
 (2) H_3PO_3 and $POCl_3$
 (3) $POCl_3$ and H_3PO_3
 (4) $POCl_3$ and H_3PO_4

Answer (2)

89. Given below are certain cations. Using inorganic qualitative analysis, arrange them in increasing group number from 0 to VI.

- A. Al^{3+}
 B. Cu^{2+}
 C. Ba^{2+}
 D. Co^{2+}
 E. Mg^{2+}

Choose the correct answer from the options given below.

- (1) E, C, D, B, A
 (2) E, A, B, C, D
 (3) B, A, D, C, E
 (4) B, C, A, D, E

Answer (3)

90. During the preparation of Mohr's salt solution (Ferrous ammonium sulphate), which of the following acid is added to prevent hydrolysis of Fe^{2+} ion?
- (1) dilute nitric acid
 - (2) dilute sulphuric acid
 - (3) dilute hydrochloric acid
 - (4) concentrated sulphuric acid

Answer (2)

91. The work done during reversible isothermal expansion of one mole of hydrogen gas at 25°C from pressure of 20 atmosphere to 10 atmosphere is
(Given $R = 2.0 \text{ cal K}^{-1} \text{ mol}^{-1}$)
- (1) 413.14 calories
 - (2) 100 calories
 - (3) 0 calorie
 - (4) -413.14 calories

Answer (4)

92. For the given reaction:

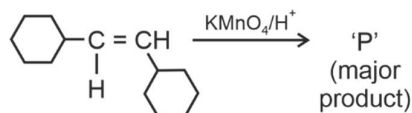

'P' is

- (1)
- (2)
- (3)
- (4)

Answer (4)

93. The plot of osmotic pressure (Π) vs concentration (mol L^{-1}) for a solution gives a straight line with slope $25.73 \text{ L bar mol}^{-1}$. The temperature at which the osmotic pressure measurement is done is
(Use $R = 0.083 \text{ L bar mol}^{-1} \text{ K}^{-1}$)
- (1) 25.73°C
 - (2) 12.05°C
 - (3) 37°C
 - (4) 310°C

Answer (3)

94. Identify the major product C formed in the following reaction sequence:

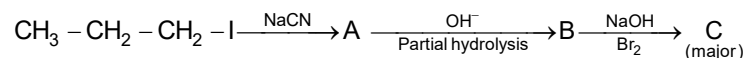

- (1) butanamide
- (2) α -bromobutanoic acid
- (3) propylamine
- (4) butylamine

Answer (3)

95. A compound X contains 32% of A, 20% of B and remaining percentage of C. Then, the empirical formula of X is :
(Given atomic masses of A = 64; B = 40; C = 32 u)
- (1) AB_2C_2 (2) ABC_4
(3) A_2BC_2 (4) ABC_3
- Answer (4)**
96. The rate of a reaction quadruples when temperature changes from 27°C to 57°C . Calculate the energy of activation.
Given $R = 8.314 \text{ J K}^{-1} \text{ mol}^{-1}$, $\log 4 = 0.6021$
- (1) 3.80 kJ/mol (2) 3804 kJ/mol
(3) 38.04 kJ/mol (4) 380.4 kJ/mol
- Answer (3)**
97. Identify the **correct** answer.
- (1) Dipole moment of NF_3 is greater than that of NH_3
(2) Three canonical forms can be drawn for CO_3^{2-} ion
(3) Three resonance structures can be drawn for ozone
(4) BF_3 has non-zero dipole moment
- Answer (2)**
98. The pair of lanthanoid ions which are diamagnetic is
- (1) Gd^{3+} and Eu^{3+}
(2) Pm^{3+} and Sm^{3+}
(3) Ce^{4+} and Yb^{2+}
(4) Ce^{3+} and Eu^{2+}
- Answer (3)**
99. Given below are two statements :
- Statement I** : $[\text{Co}(\text{NH}_3)_6]^{3+}$ is a homoleptic complex whereas $[\text{Co}(\text{NH}_3)_4\text{Cl}_2]^+$ is a heteroleptic complex.
Statement II : Complex $[\text{Co}(\text{NH}_3)_6]^{3+}$ has only one kind of ligands but $[\text{Co}(\text{NH}_3)_4\text{Cl}_2]^+$ has more than one kind of ligands.
- In the light of the above statements, choose the **correct** answer from the options given below.
- (1) Statement I is true but Statement II is false
(2) Statement I is false but Statement II is true
(3) Both Statement I and Statement II are true
(4) Both Statement I and Statement II are false
- Answer (3)**
100. Mass in grams of copper deposited by passing 9.6487 A current through a voltmeter containing copper sulphate solution for 100 seconds is (Given : Molar mass of Cu : 63 g mol^{-1} , $1 \text{ F} = 96487 \text{ C}$)
- (1) 31.5 g
(2) 0.0315 g
(3) 3.15 g
(4) 0.315 g
- Answer (4)**

BOTANY

SECTION-A

101. In the given figure, which component has thin outer walls and highly thickened inner walls?

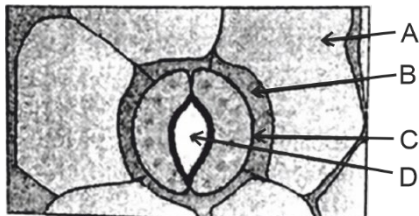

- | | |
|-------|-------|
| (1) A | (2) B |
| (3) C | (4) D |

Answer (3)

102. List of endangered species was released by

- (1) FOAM
- (2) IUCN
- (3) GEAC
- (4) WWF

Answer (2)

103. The type of conservation in which the threatened species are taken out from their natural habitat and placed in special setting where they can be protected and given special care is called

- (1) Semi-conservative method
- (2) Sustainable development
- (3) *in-situ* conservation
- (4) Biodiversity conservation

Answer (4)

104. Which one of the following can be explained on the basis of Mendel's Law of Dominance?

- A. Out of one pair of factors one is dominant and the other is recessive.
- B. Alleles do not show any expression and both the characters appear as such in F_2 generation.
- C. Factors occur in pairs in normal diploid plants.
- D. The discrete unit controlling a particular character is called factor.
- E. The expression of only one of the parental characters is found in a monohybrid cross.

Choose the correct answer from the options given below:

- (1) B, C and D only
- (2) A, B, C, D and E
- (3) A, B and C only
- (4) A, C, D and E only

Answer (4)

105. The lactose present in the growth medium of bacteria is transported to the cell by the action of
- (1) Permease
 - (2) Polymerase
 - (3) Beta-galactosidase
 - (4) Acetylase

Answer (1)

106. Match List I with List II

List I	List II
A. <i>Clostridium butylicum</i>	I. Ethanol
B. <i>Saccharomyces cerevisiae</i>	II. Streptokinase
C. <i>Trichoderma polysporum</i>	III. Butyric acid
D. <i>Streptococcus sp.</i>	IV. Cyclosporin-A

Choose the correct answer from the options given below:

- (1) A-III, B-I, C-IV, D-II
- (2) A-IV, B-I, C-III, D-II
- (3) A-III, B-I, C-II, D-IV
- (4) A-II, B-IV, C-III, D-I

Answer (1)

107. The equation of Verhulst-Pearl logistic growth is $\frac{dN}{dt} = rN \left[\frac{K-N}{K} \right]$.

From this equation, K indicates:

- (1) Carrying capacity
- (2) Population density
- (3) Intrinsic rate of natural increase
- (4) Biotic potential

Answer (1)

108. A transcription unit in DNA is defined primarily by the three regions in DNA and these are with respect to upstream and down stream end;

- (1) Inducer, Repressor, Structural gene
- (2) Promotor, Structural gene, Terminator
- (3) Repressor, Operator gene, Structural gene
- (4) Structural gene, Transposons, Operator gene

Answer (2)

109. Formation of interfascicular cambium from fully developed parenchyma cells is an example for

- (1) Dedifferentiation
- (2) Maturation
- (3) Differentiation
- (4) Redifferentiation

Answer (1)

110. Match List I with List II

	List-I		List-II
A.	<i>Rhizopus</i>	I.	Mushroom
B.	<i>Ustilago</i>	II.	Smut fungus
C.	<i>Puccinia</i>	III.	Bread mould
D.	<i>Agaricus</i>	IV.	Rust fungus

Choose the correct answer from the options given below:

- (1) A-III, B-II, C-I, D-IV
- (2) A-IV, B-III, C-II, D-I
- (3) A-III, B-II, C-IV, D-I
- (4) A-I, B-III, C-II, D-IV

Answer (3)

111. What is the fate of a piece of DNA carrying only gene of interest which is transferred into an alien organism?

- A. The piece of DNA would be able to multiply itself independently in the progeny cells of the organism.
- B. It may get integrated into the genome of the recipient.
- C. It may multiply and be inherited along with the host DNA.
- D. The alien piece of DNA is not an integral part of chromosome.
- E. It shows ability to replicate.

Choose the correct answer from the options given below:

- (1) B and C only
- (2) A and E only
- (3) A and B only
- (4) D and E only

Answer (1)

112. Match List I with List II

	List-I		List-II
A.	Nucleolus	I.	Site of formation of glycolipid
B.	Centriole	II.	Organization like the cartwheel
C.	Leucoplasts	III.	Site for active ribosomal RNA synthesis
D.	Golgi apparatus	IV.	For storing nutrients

Choose the correct answer from the options given below:

- (1) A-III, B-IV, C-II, D-I
- (2) A-I, B-II, C-III, D-IV
- (3) A-III, B-II, C-IV, D-I
- (4) A-II, B-III, C-I, D-IV

Answer (3)

113. Identify the type of flowers based on the position of calyx, corolla and androecium with respect to the ovary from the given figures (a) and (b)

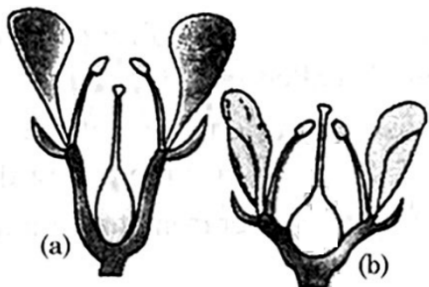

- (1) (a) Perigynous; (b) Epigynous
- (2) (a) Perigynous; (b) Perigynous
- (3) (a) Epigynous; (b) Hypogynous
- (4) (a) Hypogynous; (b) Epigynous

Answer (2)

114. Spindle fibers attach to kinetochores of chromosomes during

- (1) Anaphase
- (2) Telophase
- (3) Prophase
- (4) Metaphase

Answer (4)

115. These are regarded as major causes of biodiversity loss:

- A. Over exploitation
- B. Co-extinction
- C. Mutation
- D. Habitat loss and fragmentation
- E. Migration

Choose the correct option:

- (1) A, B and E only
- (2) A, B and D only
- (3) A, C and D only
- (4) A, B, C and D only

Answer (2)

116. Lecithin, a small molecular weight organic compound found in living tissues, is an example of:

- (1) Glycerides
- (2) Carbohydrates
- (3) Amino acids
- (4) Phospholipids

Answer (4)

117. Identify the set of **correct** statements:

- A. The flowers of *Vallisneria* are colourful and produce nectar.
- B. The flowers of water lily are not pollinated by water.
- C. In most of water-pollinated species, the pollen grains are protected from wetting.
- D. Pollen grains of some hydrophytes are long and ribbon like.
- E. In some hydrophytes, the pollen grains are carried passively inside water.

Choose the correct answer from the options given below.

- (1) A, C, D and E only
- (2) B, C, D and E only
- (3) C, D and E only
- (4) A, B, C and D only

Answer (2)

118. The cofactor of the enzyme carboxypeptidase is:

- (1) Flavin
- (2) Haem
- (3) Zinc
- (4) Niacin

Answer (3)

119. Inhibition of Succinic dehydrogenase enzyme by malonate is a classical example of:

- (1) Competitive inhibition
- (2) Enzyme activation
- (3) Cofactor inhibition
- (4) Feedback inhibition

Answer (1)

120. Which of the following is an example of actinomorphic flower?

- (1) *Pisum*
- (2) *Sesbania*
- (3) *Datura*
- (4) *Cassia*

Answer (3)

121. Given below are two statements:

Statement I : Chromosomes become gradually visible under light microscope during leptotene stage.

Statement II : The beginning of diplotene stage is recognized by dissolution of synaptonemal complex.

In the light of the above statements, choose the correct answer from the options given below:

- (1) Statement I is true but Statement II is false
- (2) Statement I is false but Statement II is true
- (3) Both Statement I and Statement II are true
- (4) Both Statement I and Statement II are false

Answer (3)

122. A pink flowered Snapdragon plant was crossed with a red flowered Snapdragon plant. What type of phenotype/s is/are expected in the progeny?
- (1) Only pink flowered plants
 - (2) Red, Pink as well as white flowered plants
 - (3) Only red flowered plants
 - (4) Red flowered as well as pink flowered plants

Answer (4)

123. Given below are two statements:

Statement I : Parenchyma is living but collenchyma is dead tissue.

Statement II : Gymnosperms lack xylem vessels but presence of xylem vessels is the characteristic of angiosperms.

In the light of the above statements, choose the correct answer from the options given below:

- (1) Statement I is true but Statement II is false
- (2) Statement I is false but Statement II is true
- (3) Both Statement I and Statement II are true
- (4) Both Statement I and Statement II are false

Answer (2)

124. Given below are two statements:

Statement I : Bt toxins are insect group specific and coded by a gene *cry IAc*.

Statement II : Bt toxin exists as inactive protoxin in *B. thuringiensis*. However, after ingestion by the insect the inactive protoxin gets converted into active form due to acidic pH of the insect gut.

In the light of the above statements, choose the correct answer from the options given below:

- (1) Statement I is true but Statement II is false
- (2) Statement I is false but Statement II is true
- (3) Both Statement I and Statement II are true
- (4) Both Statement I and Statement II are false

Answer (1)

125. Which one of the following is not a criterion for classification of fungi?

- (1) Mode of spore formation
- (2) Fruiting body
- (3) Morphology of mycelium
- (4) Mode of nutrition

Answer (4)

126. The capacity to generate a whole plant from any cell of the plant is called:

- (1) Differentiation
- (2) Somatic hybridization
- (3) Totipotency
- (4) Micropropagation

Answer (3)

127. Which of the following are required for the dark reaction of photosynthesis?

- A. Light
- B. Chlorophyll
- C. CO_2
- D. ATP
- E. NADPH

Choose the **correct** answer from the options given below:

- (1) C, D and E only
- (2) D and E only
- (3) A, B and C only
- (4) B, C and D only

Answer (1)

128. Tropical regions show greatest level of species richness because

- A. Tropical latitudes have remained relatively undisturbed for millions of years, hence more time was available for species diversification.
- B. Tropical environments are more seasonal.
- C. More solar energy is available in tropics.
- D. Constant environments promote niche specialization.
- E. Tropical environments are constant and predictable.

Choose the correct answer from the options given below.

- (1) A, B and E only
- (2) A, B and D only
- (3) A, C, D and E only
- (4) A and B only

Answer (3)

129. Identify the part of the seed from the given figure which is destined to form root when the seed germinates.

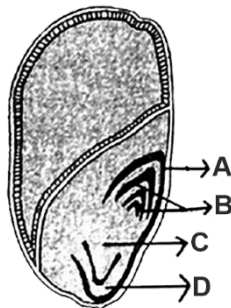

- (1) C
- (2) D
- (3) A
- (4) B

Answer (1)

130. How many molecules of ATP and NADPH are required for every molecule of CO_2 fixed in the Calvin cycle?
- (1) 3 molecules of ATP and 3 molecules of NADPH
 - (2) 3 molecules of ATP and 2 molecules of NADPH
 - (3) 2 molecules of ATP and 3 molecules of NADPH
 - (4) 2 molecules of ATP and 2 molecules of NADPH

Answer (2)

131. In a plant, black seed color (BB/Bb) is dominant over white seed color (bb). In order to find out the genotype of the black seed plant, with which of the following genotype will you cross it?
- (1) Bb
 - (2) BB/Bb
 - (3) BB
 - (4) bb

Answer (4)

132. Hind II always cuts DNA molecules at a particular point called recognition sequence and it consists of:
- (1) 4 bp
 - (2) 10 bp
 - (3) 8 bp
 - (4) 6 bp

Answer (4)

133. Bulliform cells are responsible for
- (1) Increased photosynthesis in monocots.
 - (2) Providing large spaces for storage of sugars.
 - (3) Inward curling of leaves in monocots.
 - (4) Protecting the plant from salt stress.

Answer (3)

134. Match List I with List II

List I	List II
A. Two or more alternative forms of a gene	I. Back cross
B. Cross of F_1 progeny with homozygous recessive parent	II. Ploidy
C. Cross of F_1 progeny with any of the parents	III. Allele
D. Number of chromosome sets in plant	IV. Test cross

Choose the **correct** answer from the options given below:

- (1) A-III, B-IV, C-I, D-II
- (2) A-IV, B-III, C-II, D-I
- (3) A-I, B-II, C-III, D-IV
- (4) A-II, B-I, C-III, D-IV

Answer (1)

135. Auxin is used by gardeners to prepare weed-free lawns. But no damage is caused to grass as auxin
- (1) does not affect mature monocotyledonous plants.
 - (2) can help in cell division in grasses, to produce growth.
 - (3) promotes apical dominance.
 - (4) promotes abscission of mature leaves only.

Answer (1)

SECTION-B

136. Match List I with List II

List I	List II
A. Rose	I. Twisted aestivation
B. Pea	II. Perigynous flower
C. Cotton	III. Drupe
D. Mango	IV. Marginal placentation

Choose the correct answer from the options given below :

- | | |
|----------------------------|----------------------------|
| (1) A-IV, B-III, C-II, D-I | (2) A-II, B-III, C-IV, D-I |
| (3) A-II, B-IV, C-I, D-III | (4) A-I, B-II, C-III, D-IV |

Answer (3)

137. The DNA present in chloroplast is:

- | | |
|-----------------------------|-------------------------------|
| (1) Linear, single stranded | (2) Circular, single stranded |
| (3) Linear, double stranded | (4) Circular, double stranded |

Answer (4)

138. Identify the correct description about the given figure:

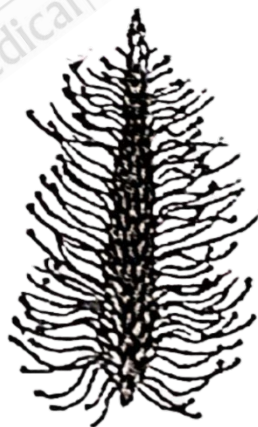

- (1) Cleistogamous flowers showing autogamy.
- (2) Compact inflorescence showing complete autogamy
- (3) Wind pollinated plant inflorescence showing flowers with well exposed stamens.
- (4) Water pollinated flowers showing stamens with mucilaginous covering.

Answer (3)

139. Match List I with List II

List I	List II
A. Robert May	I. Species-Area relationship
B. Alexander von Humboldt	II. Long term ecosystem experiment using out door plots
C. Paul Ehrlich	III. Global species diversity at about 7 million
D. David Tilman	IV. Rivet popper hypothesis

Choose the correct answer from the options given below:

- (1) A-I, B-III, C-II, D-IV (2) A-III, B-IV, C-II, D-I
 (3) A-II, B-III, C-I, D-IV (4) A-III, B-I, C-IV, D-II

Answer (4)

140. Given below are two statements:

Statement I: In C_3 plants, some O_2 binds to RuBisCO, hence CO_2 fixation is decreased.**Statement II:** In C_4 plants, mesophyll cells show very little photorespiration while bundle sheath cells do not show photorespiration.In the light of the above statements, choose the *correct* answer from the options given below:

- (1) Statement I is true but Statement II is false
 (2) Statement I is false but Statement II is true
 (3) Both Statement I and Statement II are true
 (4) Both Statement I and Statement II are false

Answer (1)

141. Identify the step in tricarboxylic acid cycle, which does not involve oxidation of substrate.

- (1) Succinyl-CoA \rightarrow Succinic acid (2) Isocitrate \rightarrow α -ketoglutaric acid
 (3) Malic acid \rightarrow Oxaloacetic acid (4) Succinic acid \rightarrow Malic acid

Answer (1)

142. Match List I with List II

	List I		List II
A.	Citric acid cycle	I.	Cytoplasm
B.	Glycolysis	II.	Mitochondrial matrix
C.	Electron transport system	III.	Intermembrane space of mitochondria
D.	Proton gradient	IV.	Inner mitochondrial membrane

Choose the correct answer from the options given below:

- (1) A-III, B-IV, C-I, D-II
 (2) A-IV, B-III, C-II, D-I
 (3) A-I, B-II, C-III, D-IV
 (4) A-II, B-I, C-IV, D-III

Answer (4)

143. Which of the following are fused in somatic hybridization involving two varieties of plants?

- | | |
|-----------------|---------------------|
| (1) Protoplasts | (2) Pollens |
| (3) Callus | (4) Somatic embryos |

Answer (1)

144. Match **List-I** with **List-II**

- | List-I | List-II |
|---------------|--|
| A. GLUT-4 | I. Hormone |
| B. Insulin | II. Enzyme |
| C. Trypsin | III. Intercellular ground substance |
| D. Collagen | IV. Enables glucose transport into cells |

Choose the correct answer from the options given below.

- | | |
|----------------------------|----------------------------|
| (1) A-II, B-III, C-IV, D-I | (2) A-III, B-IV, C-I, D-II |
| (3) A-IV, B-I, C-II, D-III | (4) A-I, B-II, C-III, D-IV |

Answer (3)

145. Match List I with List II

- | List I
(Types of Stamens) | List II
(Example) |
|--|------------------------------------|
| A. Monoadelphous | I. Citrus |
| B. Diadelphous | II. Pea |
| C. Polyadelphous | III. Lily |
| D. Epiphyllous | IV. China-rose |

Choose the correct answer from the options given below:

- | | |
|----------------------------|----------------------------|
| (1) A-I, B-II, C-IV, D-III | (2) A-III, B-I, C-IV, D-II |
| (3) A-IV, B-II, C-I, D-III | (4) A-IV, B-I, C-II, D-III |

Answer (3)

146. Read the following statements and choose the set of correct statements:

In the members of Phaeophyceae,

- Asexual reproduction occurs usually by biflagellate zoospores.
- Sexual reproduction is by oogamous method only.
- Stored food is in the form of carbohydrates which is either mannitol or laminarin.
- The major pigments found are chlorophyll a, c and carotenoids and xanthophyll.
- Vegetative cells have a cellulosic wall, usually covered on the outside by gelatinous coating of algin.

Choose the correct answer from the options given below:

- | | |
|------------------------|------------------------|
| (1) A, C, D and E only | (2) A, B, C and E only |
| (3) A, B, C and D only | (4) B, C, D and E only |

Answer (1)

147. Match List I with List II

List I

- A. Frederick Griffith
- B. Francois Jacob & Jacque Monod
- C. Har Gobind Khorana
- D. Meselson & Stahl

List II

- I. Genetic code
- II. Semi-conservative mode of DNA replication
- III. Transformation
- IV. *Lac* operon

Choose the correct answer from the options given below:

- (1) A-II, B-III, C-IV, D-I
- (2) A-IV, B-I, C-II, D-III
- (3) A-III, B-II, C-I, D-IV
- (4) A-III, B-IV, C-I, D-II

Answer (4)

148. Which of the following statement is correct regarding the process of replication in *E.coli*?

- (1) The DNA dependent DNA polymerase catalyses polymerization in $5' \rightarrow 3'$ as well as $3' \rightarrow 5'$ direction
- (2) The DNA dependent DNA polymerase catalyses polymerization in $5' \rightarrow 3'$ direction
- (3) The DNA dependent DNA polymerase catalyses polymerization in one direction that is $3' \rightarrow 5'$
- (4) The DNA dependent RNA polymerase catalyses polymerization in one direction, that is $5' \rightarrow 3'$

Answer (2)

149. Spraying sugarcane crop with which of the following plant growth regulators, increases the length of stem, thus, increasing the yield?

- (1) Cytokinin
- (2) Abscisic acid
- (3) Auxin
- (4) Gibberellin

Answer (4)

150. In an ecosystem if the Net Primary Productivity (NPP) of first trophic level is $100x \text{ (kcal m}^{-2}\text{) yr}^{-1}$, what would be the GPP (Gross Primary Productivity) of the third trophic level of the same ecosystem?

- (1) $10x \text{ (kcal m}^{-2}\text{) yr}^{-1}$
- (2) $\frac{100x}{3x} \text{ (kcal m}^{-2}\text{) yr}^{-1}$
- (3) $\frac{x}{10} \text{ (kcal m}^{-2}\text{) yr}^{-1}$
- (4) $x \text{ (kcal m}^{-2}\text{) yr}^{-1}$

Answer (1)

ZOOLOGY

SECTION-A

151. Match List I with List II :

	List I		List II
A.	Down's syndrome	I.	11 th chromosome
B.	α -Thalassemia	II.	'X' chromosome
C.	β -Thalassemia	III.	21 st chromosome
D.	Klinefelter's syndrome	IV.	16 th chromosome

Choose the correct answer from the options given below :

- (1) A-III, B-IV, C-I, D-II
- (2) A-IV, B-I, C-II, D-III
- (3) A-I, B-II, C-III, D-IV
- (4) A-II, B-III, C-IV, D-I

Answer (1)

152. Match List I with List II :

	List I (Sub Phases of Prophase I)		List II (Specific Characters)
A.	Diakinesis	I.	Synaptonemal complex formation
B.	Pachytene	II.	Completion of terminalisation of chiasmata
C.	Zygotene	III.	Chromosomes look like thin threads
D.	Leptotene	IV.	Appearance of recombination nodules

Choose the correct answer from the options given below

- (1) A-II, B-IV, C-I, D-III
- (2) A-IV, B-III, C-II, D-I
- (3) A-IV, B-II, C-III, D-I
- (4) A-I, B-II, C-IV, D-III

Answer (1)

153. Which of the following factors are favourable for the formation of oxyhaemoglobin in alveoli?

- (1) Low pCO₂ and High H⁺ concentration
- (2) Low pCO₂ and High temperature
- (3) High pO₂ and High pCO₂
- (4) High pO₂ and Lesser H⁺ concentration

Answer (4)

154. Match List I with List II :

	List I		List II
A.	Typhoid	I.	Fungus
B.	Leishmaniasis	II.	Nematode
C.	Ringworm	III.	Protozoa
D.	Filariasis	IV.	Bacteria

Choose the correct answer from the options given below:

- (1) A-III, B-I, C-IV, D-II
- (2) A-II, B-IV, C-III, D-I
- (3) A-I, B-III, C-II, D-IV
- (4) A-IV, B-III, C-I, D-II

Answer (4)

155. Match List I with List II :

	List I		List II
A.	Expiratory capacity	I.	Expiratory reserve volume + Tidal volume + Inspiratory reserve volume
B.	Functional residual capacity	II.	Tidal volume + Expiratory reserve volume
C.	Vital capacity	III.	Tidal volume + Inspiratory reserve volume
D.	Inspiratory capacity	IV.	Expiratory reserve volume + Residual volume

Choose the correct answer from the options given below :

- (1) A-II, B-I, C-IV, D-III
- (2) A-I, B-III, C-II, D-IV
- (3) A-II, B-IV, C-I, D-III
- (4) A-III, B-II, C-IV, D-I

Answer (3)

156. Which of the following are Autoimmune disorders?

- A. Myasthenia gravis
- B. Rheumatoid arthritis
- C. Gout
- D. Muscular dystrophy
- E. Systemic Lupus Erythematosus (SLE)

Choose the most appropriate answer from the options given below:

- (1) B, C & E only
- (2) C, D & E only
- (3) A, B & D only
- (4) A, B & E only

Answer (4)

157. Given below are two statements :

Statement I : In the nephron, the descending limb of loop of Henle is impermeable to water and permeable to electrolytes.

Statement II : The proximal convoluted tubule is lined by simple columnar brush border epithelium and increases the surface area for reabsorption.

In the light of the above statements, choose the correct answer from the option given below :

- (1) Statement I is true but Statement II is false
- (2) Statement I is false but Statement II is true
- (3) Both Statement I and Statement II are true
- (4) Both Statement I and Statement II are false

Answer (4)

158. Which of the following is not a steroid hormone?

- (1) Progesterone
- (2) Glucagon
- (3) Cortisol
- (4) Testosterone

Answer (2)

159. Given below are two statements : one is labelled as Assertion A and the other is labelled as Reason R :

Assertion A : FSH acts upon ovarian follicles in female and Leydig cells in male.

Reason R : Growing ovarian follicles secrete estrogen in female while interstitial cells secrete androgen in male human being.

In the light of the above statements, choose the correct answer from the options given below :

- (1) A is true but R is false
- (2) A is false but R is true
- (3) Both A and R are true and R is the correct explanation of A
- (4) Both A and R are true but R is NOT the correct explanation of A

Answer (2)

160. Given below are some stages of human evolution.

Arrange them in correct sequence. (Past to Recent)

- A. *Homo habilis*
- B. *Homo sapiens*
- C. *Homo neanderthalensis*
- D. *Homo erectus*

Choose the correct sequence of human evolution from the options given below:

- (1) C-B-D-A
- (2) A-D-C-B
- (3) D-A-C-B
- (4) B-A-D-C

Answer (2)

161. Three types of muscles are given as a, b and c. Identify the correct matching pair along with their location in human body:

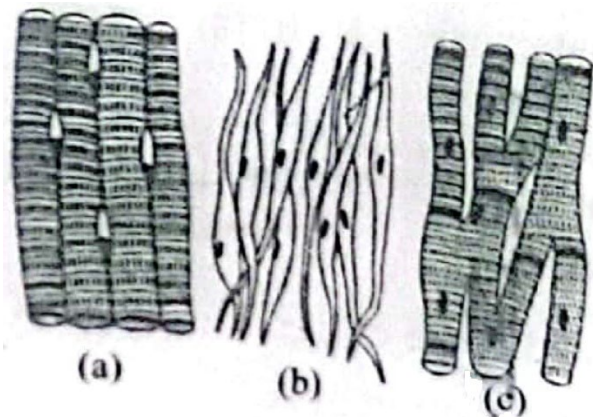

Name of muscle/location

- (1) (a) Skeletal – Biceps
 (b) Involuntary – Intestine
 (c) Smooth – Heart
- (2) (a) Involuntary – Nose tip
 (b) Skeletal – Bone
 (c) Cardiac – Heart
- (3) (a) Smooth – Toes
 (b) Skeletal – Legs
 (c) Cardiac – Heart
- (4) (a) Skeletal – Triceps
 (b) Smooth – Stomach
 (c) Cardiac – Heart

Answer (4)

162. Match List I with List II :

List I

- A. Cocaine
 B. Heroin
 C. Morphine
 D. Marijuana

List II

- I. Effective sedative in surgery
 II. *Cannabis sativa*
 III. *Erythroxylum*
 IV. *Papaver somniferum*

Choose the correct answer from the options given below:

- (1) A-II, B-I, C-III, D-IV
 (2) A-III, B-IV, C-I, D-II
 (3) A-IV, B-III, C-I, D-II
 (4) A-I, B-III, C-II, D-IV

Answer (2)

163. The "Ti plasmid" of *Agrobacterium tumefaciens* stands for
- | | |
|-------------------------------|-------------------------------------|
| (1) Tumor inducing plasmid | (2) Temperature independent plasmid |
| (3) Tumour inhibiting plasmid | (4) Tumor independent plasmid |

Answer (1)

164. Which one is the correct product of DNA dependent RNA polymerase to the given template?

3'TACATGGCAAATATCCATTCA5'

- | |
|-------------------------------|
| (1) 5'AUGUACCGUUUAUAGGGAAGU3' |
| (2) 5'ATGTACCGTTTATAGGTAAGT3' |
| (3) 5'AUGUACCGUUUAUAGGUAAGU3' |
| (4) 5'AUGUAAAGUUUAUAGGUAAGU3' |

Answer (3)

165. Match List I with List II :

List I	List II
A. <i>Pterophyllum</i>	I. Hag fish
B. <i>Myxine</i>	II. Saw fish
C. <i>Pristis</i>	III. Angel fish
D. <i>Exocoetus</i>	IV. Flying fish

Choose the correct answer from the options given below :

- | | |
|----------------------------|----------------------------|
| (1) A-IV, B-I, C-II, D-III | (2) A-III, B-II, C-I, D-IV |
| (3) A-II, B-I, C-III, D-IV | (4) A-III, B-I, C-II, D-IV |

Answer (4)

166. Match List I with List II :

List I	List II
A. Fibrous joints	I. Adjacent vertebrae, limited movement
B. Cartilaginous joints	II. Humerus and Pectoral girdle, rotational movement
C. Hinge joints	III. Skull, don't allow any movement
D. Ball and socket joints	IV. Knee, help in locomotion

Choose the correct answer from the options given below :

- | | |
|----------------------------|----------------------------|
| (1) A-II, B-III, C-I, D-IV | (2) A-III, B-I, C-IV, D-II |
| (3) A-IV, B-II, C-III, D-I | (4) A-I, B-III, C-II, D-IV |

Answer (2)

167. The flippers of the Penguins and Dolphins are the example of the

- | | |
|--------------------------|-------------------------|
| (1) Convergent evolution | (2) Divergent evolution |
| (3) Adaptive radiation | (4) Natural selection |

Answer (1)

168. Match List I with List II :

List I	List II
A. α -I antitrypsin	I. Cotton bollworm
B. Cry IAb	II. ADA deficiency
C. Cry IAc	III. Emphysema
D. Enzyme replacement therapy	IV. Corn borer

Choose the correct answer form the options given below:

- (1) A-III, B-IV, C-I, D-II
- (2) A-II, B-IV, C-I, D-III
- (3) A-II, B-I, C-IV, D-III
- (4) A-III, B-I, C-II, D-IV

Answer (1)

169. Match List I with List II :

List I	List II
A. Axoneme	I. Centriole
B. Cartwheel pattern	II. Cilia and flagella
C. Crista	III. Chromosome
D. Satellite	IV. Mitochondria

Choose the correct answer from the options given below :

- (1) A-II, B-IV, C-I, D-III
- (2) A-II, B-I, C-IV, D-III
- (3) A-IV, B-III, C-II, D-I
- (4) A-IV, B-II, C-III, D-I

Answer (2)

170. Given below are two statements: One is labelled as Assertion A and the other is labelled as Reason R:

Assertion A : Breast-feeding during initial period of infant growth is recommended by doctors for bringing a healthy baby.

Reason R : Colostrum contains several antibodies absolutely essential to develop resistance for the new born baby.

In the light of the above statements, choose the most appropriate answer from the options given below:

- (1) A is correct but R is not correct
- (2) A is not correct but R is correct
- (3) Both A and R are correct and R is the correct explanation of A
- (4) Both A and R are correct but R is NOT the correct explanation of A

Answer (3)

171. Which of the following is not a component of Fallopian tube?

- (1) Infundibulum (2) Ampulla
(3) Uterine fundus (4) Isthmus

Answer (3)

172. Which of the following statements is incorrect?

- (1) Bio-reactors are used to produce small scale bacterial cultures
(2) Bio-reactors have an agitator system, an oxygen delivery system and foam control system
(3) A bio-reactor provides optimal growth conditions for achieving the desired product
(4) Most commonly used bio-reactors are of stirring type

Answer (1)

173. Match List I with List II :

	List I		List II
A.	Pons	I.	Provides additional space for Neurons, regulates posture and balance.
B.	Hypothalamus	II.	Controls respiration and gastric secretions.
C.	Medulla	III.	Connects different regions of the brain.
D.	Cerebellum	IV.	Neuro secretory cells

Choose the correct answer from the options given below :

- (1) A-I, B-III, C-II, D-IV (2) A-II, B-I, C-III, D-IV
(3) A-II, B-III, C-I, D-IV (4) A-III, B-IV, C-II, D-I

Answer (4)

174. Match List I with List II :

	List-I		List-II
A.	Lipase	I.	Peptide bond
B.	Nuclease	II.	Ester bond
C.	Protease	III.	Glycosidic bond
D.	Amylase	IV.	Phosphodiester bond

Choose the correct answer from the options given below :

- (1) A-II, B-IV, C-I, D-III (2) A-IV, B-I, C-III, D-II
(3) A-IV, B-II, C-III, D-I (4) A-III, B-II, C-I, D-IV

Answer (1)

175. Which of the following is not a natural/traditional contraceptive method?

- (1) Lactational amenorrhea
(2) Vaults
(3) Coitus interruptus
(4) Periodic abstinence

Answer (2)

176. Following are the stages of pathway for conduction of an action potential through the heart

- | | |
|--------------|--------------------|
| A. AV bundle | B. Purkinje fibres |
| C. AV node | D. Bundle branches |
| E. SA node | |

Choose the correct sequence of pathway from the options given below

- | | |
|---------------|---------------|
| (1) B-D-E-C-A | (2) E-A-D-B-C |
| (3) E-C-A-D-B | (4) A-E-C-B-D |

Answer (3)

177. Match List I with List II :

	List I		List II
A.	Pleurobrachia	I.	Mollusca
B.	Radula	II.	Ctenophora
C.	Stomochord	III.	Osteichthyes
D.	Air bladder	IV.	Hemichordata

Choose the correct answer from the options given below :

- | | |
|----------------------------|----------------------------|
| (1) A-II, B-IV, C-I, D-III | (2) A-IV, B-III, C-II, D-I |
| (3) A-IV, B-II, C-III, D-I | (4) A-II, B-I, C-IV, D-III |

Answer (4)

178. Match List I with List II :

List I	List II
A. Common cold	I. <i>Plasmodium</i>
B. Haemozoin	II. Typhoid
C. Widal test	III. Rhinoviruses
D. Allergy	IV. Dust mites

Choose the correct answer from the options given below :

- | |
|----------------------------|
| (1) A-III, B-I, C-II, D-IV |
| (2) A-IV, B-II, C-III, D-I |
| (3) A-II, B-IV, C-III, D-I |
| (4) A-I, B-III, C-II, D-IV |

Answer (1)

179. Consider the following statements :

- | |
|---|
| A. Annelids are true coelomates |
| B. Poriferans are pseudocoelomates |
| C. Aschelminthes are acoelomates |
| D. Platyhelminthes are pseudocoelomates |

Choose the correct answer from the options given below :

- | | |
|------------|------------|
| (1) C only | (2) D only |
| (3) B only | (4) A only |

Answer (4)

180. In both sexes of cockroach, a pair of jointed filamentous structures called anal cerci are present on
- | | |
|---|------------------------------|
| (1) 8 th and 9 th segment | (2) 11 th segment |
| (3) 5 th segment | (4) 10 th segment |

Answer (4)

181. Given below are two statements:

Statement I: The presence or absence of hymen is not a reliable indicator of virginity.

Statement II: The hymen is torn during the first coitus only.

In the light of the above statements, choose the correct answer from the options given below :

- | | |
|---|---|
| (1) Statement I is true but Statement II is false | (2) Statement I is false but Statement II is true |
| (3) Both Statement I and Statement II are true | (4) Both Statement I and Statement II are false |

Answer (1)

182. Which one of the following factors will not affect the Hardy-Weinberg equilibrium?

- (1) Gene migration
- (2) Constant gene pool
- (3) Genetic recombination
- (4) Genetic drift

Answer (2)

183. The following diagram showing restriction sites in *E. coli* cloning vector pBR322. Find the role of 'X' and 'Y' genes :

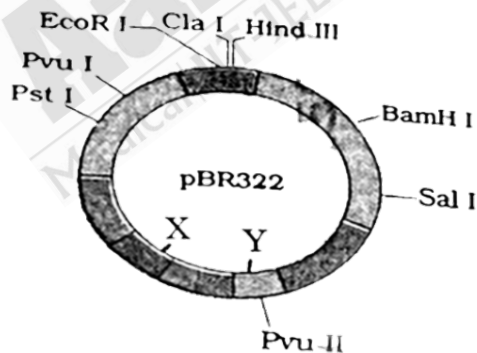

- (1) The gene 'X' is for protein involved in replication of Plasmid and 'Y' for resistance to antibiotics.
- (2) Gene 'X' is responsible for recognitions sites and 'Y' is responsible for antibiotic resistance.
- (3) The gene 'X' is responsible for resistance to antibiotics and 'Y' for protein involved in the replication of Plasmid.
- (4) The gene 'X' is responsible for controlling the copy number of the linked DNA and 'Y' for protein involved in the replication of Plasmid.

Answer (4)

188. Given below are two statements:

Statement I: Mitochondria and chloroplasts both double membranes bound organelles.

Statement II: Inner membrane of mitochondria is relatively less permeable, as compared chloroplast.

In the light of the above statements, choose the mis appropriate answer from the options given below:

- (1) Statement I is correct but Statement II is incorrect.
- (2) Statement I is incorrect but Statement II is correct.
- (3) Both Statement I and Statement II are correct.
- (4) Both Statement I and Statement II are incorrect.

Answer (1)

189. Regarding catalytic cycle of an enzyme action, select the correct sequential steps :

- A. Substrate enzyme complex formation.
- B. Free enzyme ready to bind with another substrate.
- C. Release of products.
- D. Chemical bonds of the substrate broken.
- E. Substrate binding to active site.

Choose the correct answer from the options given below :

- (1) B, A, C, D, E
- (2) E, D, C, B, A
- (3) E, A, D, C, B
- (4) A, E, B, D, C

Answer (3)

190. Match List I with List II :

	List I		List II
A.	P wave	I.	Heart muscles are electrically silent.
B.	QRS complex	II.	Depolarisation of ventricles.
C.	T wave	III.	Depolarisation of atria.
D.	T-P gap	IV.	Repolarisation of ventricles.

Choose the correct answer from the options given below :

- (1) A-II, B-III, C-I, D-IV
- (2) A-IV, B-II, C-I, D-III
- (3) A-I, B-III, C-IV, D-II
- (4) A-III, B-II, C-IV, D-I

Answer (4)

191. Given below are two statements :

Statement I : Bone marrow is the main lymphoid organ where all blood cells including lymphocytes are produced.

Statement II : Both bone marrow and thymus provide micro environments for the development and maturation of T-lymphocytes.

In the light of above statements, choose the most appropriate answer from the options given below :

- (1) Statement I is correct but Statement II is incorrect.
- (2) Statement I is incorrect but Statement II is correct.
- (3) Both Statement I and Statement II are correct.
- (4) Both Statement I and Statement II are incorrect.

Answer (3)

192. Match List I with List II:

	List I		List II
A.	Unicellular glandular epithelium	I.	Salivary glands
B.	Compound epithelium	II.	Pancreas
C.	Multicellular glandular epithelium	III.	Goblet cells of alimentary canal
D.	Endocrine glandular epithelium	IV.	Moist surface of buccal cavity

Choose the correct answer from the options given below:

- (1) A-III, B-IV, C-I, D-II
- (2) A-II, B-I, C-IV, D-III
- (3) A-II, B-I, C-III, D-IV
- (4) A-IV, B-III, C-I, D-II

Answer (1)

193. Given below are two statements:

Statement I: The cerebral hemispheres are connected by nerve tract known as corpus callosum.

Statement II: The brain stem consists of the medulla oblongata, pons and cerebrum.

In the light of the above statements, choose the most appropriate answer from the options given below:

- (1) Statement I is correct but Statement II is incorrect.
- (2) Statement I is incorrect but Statement II is correct.
- (3) Both Statement I and Statement II are correct.
- (4) Both Statement I and Statement II are incorrect.

Answer (1)

194. Match List I with List II:

	List I		List II
A.	RNA polymerase III	I.	snRNPs
B.	Termination of transcription	II.	Promotor
C.	Splicing of Exons	III.	Rho factor
D.	TATA box	IV.	SnRNAs, tRNA

Choose the correct answer from the options given below :

- (1) A-III, B-IV, C-I, D-II
- (2) A-IV, B-III, C-I, D-II
- (3) A-II, B-IV, C-I, D-III
- (4) A-III, B-II, C-IV, D-I

Answer (2)

195. Match List I with List II:

	List I		List II
A.	Mesozoic Era	I.	Lower invertebrates
B.	Proterozoic Era	II.	Fish & Amphibia
C.	Cenozoic Era	III.	Birds & Reptiles
D.	Paleozoic Era	IV.	Mammals

Choose the correct answer from the options given below :

- (1) A-I, B-II, C-IV, D-III
- (2) A-III, B-I, C-IV, D-II
- (3) A-II, B-I, C-III, D-IV
- (4) A-III, B-I, C-II, D-IV

Answer (2)

196. Given below are two statements:

Statement I: Gause's competitive exclusion principle states that two closely related species competing for different resources cannot exist indefinitely.

Statement II: According to Gause's principle, during competition, the inferior will be eliminated. This may be true if resources are limiting.

In the light of the above statements, choose the correct answer from the options given below :

- (1) Statement I is true but Statement II is false.
- (2) Statement I is false but Statement II is true.
- (3) Both Statement I and Statement II are true.
- (4) Both Statement I and Statement II are false.

Answer (2)

197. Match List I with List II :

	List I		List II
A.	Exophthalmic goiter	I.	Excess secretion of cortisol, moon face & hyperglycemia.
B.	Acromegaly	II.	Hypo-secretion of thyroid hormone and stunted growth.
C.	Cushing's syndrome	III.	Hyper secretion of thyroid hormone & protruding eye balls.
D.	Cretinism	IV.	Excessive secretion of growth hormone.

Choose the correct answer from the options given below :

- (1) A-III, B-IV, C-II, D-I
- (2) A-III, B-IV, C-I, D-II
- (3) A-I, B-III, C-II, D-IV
- (4) A-IV, B-II, C-I, D-III

Answer (2)

198. Identify the correct option (A), (B), (C), (D) with respect to spermatogenesis.

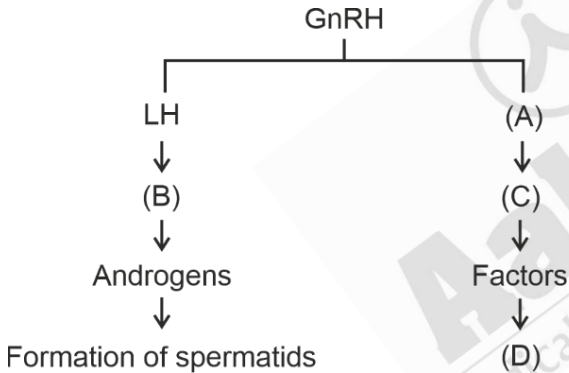

- (1) FSH, Sertoli cells, Leydig cells, spermatogenesis.
- (2) ICSH, Leydig cells, Sertoli cells, spermatogenesis.
- (3) FSH, Leydig cells, Sertoli cells, spermiogenesis.
- (4) ICSH, Interstitial cells, Leydig cells, spermiogenesis.

Answer (3)

199. As per ABO blood grouping system, the blood group of father is B⁺, mother is A⁺ and child is O⁺. Their respective genotype can be

- | | |
|--|---|
| A. I ^B i/I ^A /ii | B. I ^B I ^B /I ^A I ^A /ii |
| C. I ^A I ^B /iiI ^A /I ^B i | D. I ^A i/I ^B i/I ^A i |
| E. iiI ^B /iiI ^A /I ^A I ^B | |

Choose the most appropriate answer from the options given below :

- | | |
|----------------|----------------|
| (1) C & B only | (2) D & E only |
| (3) A only | (4) B only |

Answer (3)

200. Match List I with List II related to digestive system of cockroach.

	List I		List II
A.	The structures used for storing of food	I.	Gizzard
B.	Ring of 6-8 blind tubules at junction of foregut and midgut.	II.	Gastric Caeca
C.	Ring of 100-150 yellow coloured thin filaments at junction of midgut and hindgut.	III.	Malpighian tubules
D.	The structures used for grinding the food.	IV.	Crop

Choose the correct answer from the options given below:

- (1) A-IV, B-III, C-II, D-I
- (2) A-III, B-II, C-IV, D-I
- (3) A-IV, B-II, C-III, D-I
- (4) A-I, B-II, C-III, D-IV

Answer (3)

