

**C1**

Corporate Office : Aakash Tower, 8, Pusa Road, New Delhi-110005 | Ph.: 011-47623456

## Answers & Solutions

Time : 3 hrs. 20 Min.

*for*

M.M. : 720

# Re-Examination of NEET (UG)-2024

### Important Instructions:

- The test is of **3 hours 20 minutes** duration and the Test Booklet contains **200** multiple-choice questions (four options with a single correct answer) from **Physics, Chemistry and Biology (Botany and Zoology)**. 50 questions in each subject are divided into **two Sections (A and B)** as per details given below:
  - Section-A** shall consist of **35 (Thirty-five)** Questions in each subject (Question Nos-1 to 35, 51 to 85, 101 to 135 and 151 to 185). All Questions are compulsory.
  - Section-B** shall consist of **15 (Fifteen)** questions in each subject (Question Nos- 36 to 50, 86 to 100, 136 to 150 and 186 to 200). In **Section B**, a candidate needs to **attempt any 10 (Ten)** questions out of **15 (Fifteen)** in each subject.

**Candidates are advised to read all 15 questions in each subject of Section B** before they start attempting the question paper. In the event of a candidate attempting more than ten questions, **the first ten questions answered by the candidate shall be evaluated.**
- Each question carries **4 marks**. For each correct response, the candidate will get **4 marks**. For each incorrect response, **one mark** will be deducted from the total scores. **The maximum marks are 720.**
- Use **Blue / Black Ball Point Pen only** for writing particulars on this page / marking responses on Answer Sheet.
- Rough work is to be done in the space provided for this purpose in the Test Booklet only.
- On completion of the test, the candidate must **hand over the Answer Sheet (ORIGINAL and OFFICE copy) to the invigilator** before leaving the Room / Hall. The candidates are allowed to take away this Test Booklet with them.
- The CODE for this Booklet is C1. Make sure that the CODE printed on the Original Copy of the Answer Sheet is the same as that on this Test Booklet.** In case of discrepancy, the candidate should immediately report the matter to the Invigilator for replacement of both the Test Booklet and the Answer sheet.
- The candidates should ensure that the Answer Sheet is not folded. Do not make any stray marks on the Answer Sheet. Do not write your Roll No. anywhere else except in the specified space in the Test Booklet/Answer Sheet.
- Use of white fluid for correction is **NOT** permissible on the Answer Sheet.
- Each candidate must show on-demand his/her Admission Card to the Invigilator.
- No candidate, without special permission of the Centre Superintendent or Invigilator, would leave his/her seat.
- Use of Electronic/Manual Calculator is prohibited.
- The candidates are governed by all Rules and Regulations of the examination with regard to their conduct in the Examination Room / Hall. All cases of unfair means will be dealt with as per Rules and Regulations of this examination.
- No part of the Test Booklet and Answer Sheet shall be detached under any circumstances.**
- The candidates will write the Correct Test Booklet Code as given in the Test Booklet / Answer Sheet in the Attendance Sheet.

**PHYSICS**

**SECTION-A**

1. The magnetic potential energy, when a magnetic bar of magnetic moment  $\vec{m}$  is placed perpendicular to the magnetic field  $\vec{B}$  is

- (1)  $-\frac{mB}{2}$  (2) Zero  
(3)  $-mB$  (4)  $mB$

**Answer (2)**

**Sol.** Potential energy stored in external magnetic field is given by  $U = -\vec{m} \cdot \vec{B}$

$\therefore$  Angle between  $\vec{m}$  and  $\vec{B}$  is  $90^\circ$

$\therefore U = -mB \cos 90^\circ$

$$= 0$$

2. A bob is whirled in a horizontal circle by means of a string at an initial speed of 10 rpm. If the tension in the string is quadrupled while keeping the radius constant, the new speed is:

- (1) 20 rpm (2) 40 rpm  
(3) 5 rpm (4) 10 rpm

**Answer (1)**

**Sol.** In horizontal circular motion,

$$T = m\omega^2 r$$

For constant  $m$  and  $r$ ,  $T \propto \omega^2$

$$T = 4T \text{ (Given)}$$

$$\Rightarrow \omega' = 2\omega$$

$$= 20 \text{ rpm}$$

3. A metal cube of side 5 cm is charged with  $6 \mu\text{C}$ . The surface charge density on the cube is

- (1)  $0.125 \times 10^{-3} \text{ C m}^{-2}$  (2)  $0.25 \times 10^{-3} \text{ C m}^{-2}$   
(3)  $4 \times 10^{-3} \text{ C m}^{-2}$  (4)  $0.4 \times 10^{-3} \text{ C m}^{-2}$

**Answer (4)**

**Sol.**  $\Rightarrow$  In metal all the charge is present on surface.

$$Q = 6 \mu\text{C}$$

$$\text{Total surface area } S = 6a^2$$

$$= 6 \times (5 \times 10^{-2})^2$$

$$= 6 \times 25 \times 10^{-4}$$

$$= 150 \times 10^{-4} \text{ m}^2$$

$$\text{Surface charge density } \sigma = \frac{Q}{S}$$

$$= \frac{6 \times 10^{-6}}{150 \times 10^{-4}}$$

$$= 0.4 \times 10^{-3} \text{ C m}^{-2}$$

4. The incorrect relation for a diamagnetic material (all the symbols carry their usual meaning and  $\epsilon$  is a small positive number) is

- (1)  $\mu < \mu_0$  (2)  $0 \leq \mu_r < 1$   
 (3)  $-1 \leq \chi < 0$  (4)  $1 < \mu_r < 1 + \epsilon$

**Answer (4)**

**Sol.** For diamagnetic material,

$$0 \leq \mu_r < 1$$

$$\chi = \mu_r - 1$$

$$\Rightarrow -1 \leq \chi < 0$$

$$\mu_r = \frac{\mu}{\mu_0}$$

$$\Rightarrow \mu < \mu_0 \quad (\because \mu_r < 1)$$

5. An ideal fluid is flowing in a non-uniform cross-sectional tube XY (as shown in the figure) from end X to end Y. If  $K_1$  and  $K_2$  are the kinetic energy per unit volume of the fluid at X and Y respectively, then the correct option is :

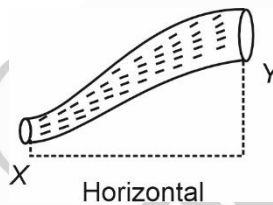

- (1)  $K_1 = K_2$  (2)  $2K_1 = K_2$   
 (3)  $K_1 > K_2$  (4)  $K_1 < K_2$

**Answer (3)**

**Sol.** According to Bernoulli's principle,

Kinetic energy per unit volume + Potential energy per unit volume + Pressure = Constant

$$\frac{1}{2}\rho V^2 + \rho gh + P = \text{constant}$$

Apply Bernoulli's principle at point X and Y,

$$P + K_1 + \rho g(0) = P + K_2 + \rho g(h)$$

$$K_1 = K_2 + \rho gh$$

$$K_1 > K_2$$

6. The escape velocity for earth is  $v$ . A planet having 9 times mass that of earth and radius, 16 times that of earth, has the escape velocity of:

- (1)  $\frac{v}{3}$  (2)  $\frac{2v}{3}$   
 (3)  $\frac{3v}{4}$  (4)  $\frac{9v}{4}$

**Answer (3)**

**Sol.** Escape velocity of object from planet is given by

$$(v_e)_p = \sqrt{\frac{2GM_p}{R_p}}$$

$$\therefore (v_e)_p \propto \sqrt{\frac{M_p}{R_p}}$$

Now,  $M_p = 9M_e$  and  $R_p = 16R_e$  (given)

$$\frac{(v_e)_p}{(v_e)_e} = \sqrt{\frac{M_p}{R_p} \times \frac{R_e}{M_e}} = \sqrt{\frac{9M_e}{16R_e} \times \frac{R_e}{M_e}} = \sqrt{\frac{9}{16}} = \frac{3}{4}$$

$$\Rightarrow (v_e)_p = \frac{3}{4}v$$

7. An electron and an alpha particle are accelerated by the same potential difference. Let  $\lambda_e$  and  $\lambda_\alpha$  denote the de-Broglie wavelengths of the electron and the alpha particle, respectively, then:

- (1)  $\lambda_e > \lambda_\alpha$  (2)  $\lambda_e = 4\lambda_\alpha$   
 (3)  $\lambda_e = \lambda_\alpha$  (4)  $\lambda_e < \lambda_\alpha$

**Answer (1)**

**Sol.** de-Broglie wavelength is given by

$$\lambda = \frac{h}{p} = \frac{h}{\sqrt{2mqV}}$$

For same potential difference

$$\lambda \propto \frac{1}{\sqrt{mq}}$$

$$\frac{\lambda_\alpha}{\lambda_e} = \sqrt{\frac{m_e q_e}{m_\alpha q_\alpha}}$$

$$\therefore m_\alpha \gg m_e$$

$$\lambda_e > \lambda_\alpha$$

8. An object moving along horizontal x-direction with kinetic energy 10 J is displaced through  $x = (3\hat{i})$  m by the force  $\vec{F} = (-2\hat{i} + 3\hat{j})$  N. The kinetic energy of the object at the end of the displacement x is

- (1) 10 J (2) 16 J  
 (3) 4 J (4) 6 J

**Answer (3)**

**Sol.** Work energy theorem,

$$W_{\text{all}} = \Delta \text{K.E.} \quad (W_{\text{all}} = \text{work done by all forces})$$

$$\Rightarrow K_f - K_i = \vec{F} \cdot \Delta \vec{x}$$

$$\Rightarrow K_f - 10 = (-2\hat{i} + 3\hat{j}) \cdot (3\hat{i})$$

$$K_f - 10 = -6$$

$$K_f = 4 \text{ J}$$

9. An object falls from a height of 10 m above the ground. After striking the ground it loses 50% of its kinetic energy. The height upto which the object can rebound from the ground is:

- (1) 7.5 m (2) 10 m  
(3) 2.5 m (4) 5 m

**Answer (4)**

**Sol.** K.E. just before striking the ground  $K_1 = mgh_1 = mg(10)$

$$\text{K.E. just after striking the ground} = K_1 - \frac{50}{100} K_1 = \frac{50}{100} K_1 = \frac{K_1}{2} = K_2$$

$$\text{Now, } K_2 = mgh_2$$

$$\Rightarrow \frac{K_1}{2} = mgh_2$$

$$\Rightarrow \frac{mg(10)}{2} = mgh_2 \Rightarrow h_2 = 5 \text{ m}$$

10. In the circuit shown below, the inductance  $L$  is connected to an ac source. The current flowing in the circuit is  $I = I_0 \sin \omega t$ . The voltage drop ( $V_L$ ) across  $L$  is

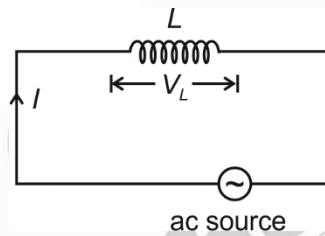

- (1)  $\omega L I_0 \sin \omega t$  (2)  $\frac{I_0}{\omega L} \sin \omega t$   
(3)  $\frac{I_0}{\omega L} \cos \omega t$  (4)  $\omega L I_0 \cos \omega t$

**Answer (4)**

**Sol.**  $V_L$  leads current  $I$  by  $\frac{\pi}{2}$

$$\therefore V_L = V_0 \sin\left(\omega t + \frac{\pi}{2}\right) \quad (\because I = I_0 \sin \omega t)$$

$$V_0 = I_0 X_L$$

$$\Rightarrow V_L = I_0 X_L \cos(\omega t) = I_0 \omega L \cos(\omega t)$$

11. A 12 pF capacitor is connected to a 50 V battery, the electrostatic energy stored in the capacitor in nJ is

- (1) 15  
(2) 7.5  
(3) 0.3  
(4) 150

**Answer (1)**

**Sol.** Electrostatic energy stored  $U = \frac{1}{2} CV^2$

$$= \frac{1}{2} \times 12 \times 10^{-12} \times (50)^2$$

$$= 6 \times 25 \times 10^{-10}$$

$$= 15 \times 10^{-9} \text{ J}$$

$$= 15 \text{ nJ}$$

12. A uniform wire of diameter  $d$  carries a current of 100 mA when the mean drift velocity of electrons in the wire is  $v$ . For a wire of diameter  $\frac{d}{2}$  of the same material to carry a current of 200 mA, the mean drift velocity of electrons in the wire is

(1)  $4v$

(2)  $8v$

(3)  $v$

(4)  $2v$

**Answer (2)**

**Sol.** current  $i = nAv_d e$

( $v_d =$  mean drift velocity)

$$= n \left( \frac{\pi D^2}{4} \right) v_d e$$

$$\therefore i \propto D^2 v_d$$

$$\frac{100}{200} = \frac{(d)^2}{\left(\frac{d}{2}\right)^2} \times \frac{v}{v'}$$

$$\Rightarrow v' = 2 \times 2^2 v = 8v$$

13. In an electrical circuit, the voltage is measured as  $V = (200 \pm 4)$  volt and the current is measured as  $I = (20 \pm 0.2)$  A. The value of the resistance is:

(1)  $(10 \pm 4.2) \Omega$

(2)  $(10 \pm 0.3) \Omega$

(3)  $(10 \pm 0.1) \Omega$

(4)  $(10 \pm 0.8) \Omega$

**Answer (2)**

**Sol.**  $R = \frac{V}{I} = \frac{200}{20} = 10 \Omega$

$$\frac{\Delta R}{R} = \frac{\Delta V}{V} + \frac{\Delta I}{I} = \frac{4}{200} + \frac{0.2}{20} = \frac{4+2}{200} = \frac{6}{200}$$

$$\Rightarrow \Delta R = \frac{6}{200} \times R = \frac{6}{20} = \frac{3}{10} = 0.3 \Omega$$

$$\therefore \text{Resistance} = R \pm \Delta R = (10 \pm 0.3) \Omega$$

14. A step up transformer is connected to an ac mains supply of 220 V to operate at 11000 V, 88 watt. The current in the secondary circuit, ignoring the power loss in the transformer, is

(1) 8 mA

(2) 4 mA

(3) 0.4 A

(4) 4 A

**Answer (1)**

**Sol.** In secondary circuit,  $P = Vi$

$$\Rightarrow 88 = 11000 i$$

$$\Rightarrow i = \frac{88}{11 \times 10^3} = 8 \times 10^{-3} \text{ A}$$

$$\Rightarrow i = 8 \text{ mA}$$

15. A particle is moving along x-axis with its position ( $x$ ) varying with time ( $t$ ) as  $x = \alpha t^4 + \beta t^2 + \gamma t + \delta$ . The ratio of its initial velocity to its initial acceleration, respectively, is:

(1)  $2\alpha : \delta$

(2)  $\gamma : 2\delta$

(3)  $4\alpha : \beta$

(4)  $\gamma : 2\beta$

**Answer (4)**

**Sol.** Position of particle,  $x = \alpha t^4 + \beta t^2 + \gamma t + \delta$

$$\text{Velocity } v = \frac{dx}{dt} = 4\alpha t^3 + 2\beta t + \gamma$$

$$\text{Initial velocity} = v(t=0) = \gamma$$

$$\text{Acceleration } a = \frac{dv}{dt} = 12\alpha t^2 + 2\beta$$

$$\text{Initial acceleration} = a(t=0) = 2\beta$$

$$\therefore \frac{v(t=0)}{a(t=0)} = \frac{\gamma}{2\beta}$$

16. The radius of gyration of a solid sphere of mass 5 kg about XY is 5 m as shown in figure. The radius of the sphere is  $\frac{5x}{\sqrt{7}}$  m, then the value of x is:

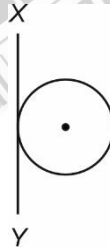

(1) 5

(2)  $\sqrt{2}$

(3)  $\sqrt{3}$

(4)  $\sqrt{5}$

**Answer (4)**

$$\text{Sol. } I_{XY} = I_{CM} + MR^2 = \frac{2}{5}MR^2 + MR^2 = \frac{7}{5}MR^2 = \frac{7}{5} \times 5R^2 = 7R^2 \quad \dots (1)$$

$$I_{XY} = MK^2 = 5 \times 5^2 \quad \dots (2)$$

$$\therefore 5 \times 5^2 = 7 \times R^2 \quad [\text{From (1) and (2)}]$$

$$\Rightarrow R = \sqrt{\frac{5}{7}} \times 5 = \frac{5x}{\sqrt{7}} \quad (\text{Given})$$

$$\therefore x = \sqrt{5}$$





**Sol.** Capacitance of capacitor  $C = \frac{A\epsilon_0}{d}$

so capacitance of capacitor is independent of charge ( $q$ ) and potential ( $V$ ), it depends on geometry of the capacitor and medium between plates of the capacitor.

20. Given below are two statements:

**Statement I :** Image formation needs regular reflection and/or refraction.

**Statement II :** The variety in colour of objects we see around us is due to the constituent colours of the light incident on them.

In the light of the above statements, choose **the most appropriate** answer from the options given below :

- (1) Statement I is correct but statement II is incorrect
- (2) Statement I is incorrect but Statement II is correct
- (3) Both Statement I and Statement II are correct
- (4) Both Statement I and Statement II are incorrect

**Answer (3)**

**Sol.** • Regular reflection is necessary for image formation, that is why we can see our image in a mirror but not in wall.

Different colours in white light as its constituent are responsible for the variety in colour of objects.

21. A uniform metal wire of length  $l$  has  $10 \Omega$  resistance. Now this wire is stretched to a length  $2l$  and then bent to form a perfect circle. The equivalent resistance across any arbitrary diameter of that circle is

- (1)  $10 \Omega$
- (2)  $5 \Omega$
- (3)  $40 \Omega$
- (4)  $20 \Omega$

**Answer (1)**

**Sol.**  $R_0 = 10 \Omega$

After stretching its length upto  $2l$

$$\begin{aligned} R_1 &= n^2 R_0 \\ &= 4R_0 \\ &= 40 \Omega \end{aligned}$$

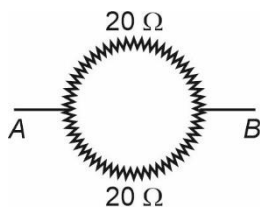

$$R_{AB} = \frac{20 \times 20}{20 + 20} = 10 \Omega$$

22. The spectral series which corresponds to the electronic transition from the levels  $n_2 = 5, 6, \dots$  to the level  $n_1 = 4$  is

- (1) Pfund series
- (2) Brackett series
- (3) Lyman series
- (4) Balmer series

**Answer (2)**

**Sol.** The spectral series which corresponds to the electronic transition from the levels  $n_2 = 5, 6, \dots$  to  $n_1 = 4$  is Brackett series.

23. Given below are two statements: One is labelled as **Assertion A** and the other is labelled as **Reason R**.

**Assertion A:** Houses made of concrete roofs overlaid with foam keep the room hotter during summer.

**Reason R:** The layer of foam insulation prohibits heat transfer, as it contains air pockets.

In the light of the above statements, choose the **correct** answer from the options given below.

- (1) **A** is true but **R** is false.
- (2) **A** is false but **R** is true.
- (3) Both **A** and **R** are true and **R** is the correct explanation of **A**.
- (4) Both **A** and **R** true but **R** is NOT the correct explanation of **A**.

**Answer (2)**

**Sol.** Layer of foam create an insulation which prohibits heat transfer, and hence roofs of houses containing foam keep room cooler during summer.

24. A particle executing simple harmonic motion with amplitude  $A$  has the same potential and kinetic energies at the displacement

- (1)  $2\sqrt{A}$
- (2)  $\frac{A}{2}$
- (3)  $\frac{A}{\sqrt{2}}$
- (4)  $A\sqrt{2}$

**Answer (3)**

**Sol.** Potential energy =  $\frac{1}{2}kx^2$

$$\text{Kinetic energy} = \frac{1}{2}kA^2 - \frac{1}{2}kx^2$$

According to given condition

$$\frac{1}{2}kx^2 = \frac{1}{2}kA^2 - \frac{1}{2}kx^2$$

$$k2x^2 = kA^2$$

$$x^2 = \frac{A^2}{2}$$

$$x = \frac{A}{\sqrt{2}}$$

25. Two slits in Young's double slit experiment are 1.5 mm apart and the screen is placed at a distance of 1 m from the slits. If the wavelength of light used is  $600 \times 10^{-9}$  m then the fringe separation is

- (1)  $4 \times 10^{-5}$  m
- (2)  $9 \times 10^{-8}$  m
- (3)  $4 \times 10^{-7}$  m
- (4)  $4 \times 10^{-4}$  m

**Answer (4)**

**Sol.** Fringe width = Fringe separation ( $\beta$ ) =  $\frac{\lambda D}{d}$

$$\Rightarrow \beta = \frac{600 \times 10^{-9} \times 1}{1.5 \times 10^{-3}} = \frac{6 \times 10^{-7}}{1.5 \times 10^{-3}} = 4 \times 10^{-4} \text{ m}$$

26. Water is used as a coolant in a nuclear reactor because of its
- (1) high thermal expansion coefficient                      (2) high specific heat capacity  
 (3) low density    (4) low boiling point

**Answer (2)**

**Sol.** Water is used as a coolant in nuclear reactor because of its high specific heat capacity.

27. The pitch of an error free screw gauge is 1 mm and there are 100 divisions on the circular scale. While measuring the diameter of a thick wire, the pitch scale reads 1 mm and 63<sup>rd</sup> division on the circular scale coincides with the reference line. The diameter of the wire is:
- (1) 1.63 cm    (2) 0.163 cm  
 (3) 0.163 m    (4) 1.63 m

**Answer (2)**

**Sol.** Least count of screw gauge =  $\frac{\text{Pitch}}{\text{No. of divisions on circular scale}}$

$$\Rightarrow \text{Least count} = \frac{1}{100} = 0.01 \text{ mm}$$

$$\begin{aligned} \text{Final reading} &= \text{MSR} + \text{CSR} \times \text{L.C.} \\ &= 1 \text{ mm} + (63) (0.01) \text{ mm} \\ &= 1.63 \text{ mm} \\ &= 0.163 \text{ cm} \end{aligned}$$

28. Let us consider two solenoids *A* and *B*, made from same magnetic material of relative permeability  $\mu_r$  and equal area of cross-section. Length of *A* is twice that of *B* and the number of turns per unit length in *A* is half that of *B*. The ratio of self inductances of the two solenoids,  $L_A : L_B$  is
- (1) 1 : 2    (2) 2 : 1  
 (3) 8 : 1    (4) 1 : 8

**Answer (1)**

**Sol.**  $L = \mu_0 \mu_r \times n \times A \times N$

$$L = \mu_0 \mu_r n \times A \times \frac{N}{l} \times l$$

$$L = \mu_0 \mu_r \times n^2 \times A \times l \Rightarrow L \propto n^2 l$$

$$\Rightarrow \frac{L_A}{L_B} = \frac{n_A^2}{n_B^2} \times \frac{l_A}{l_B}$$

$$\Rightarrow \frac{L_A}{L_B} = \frac{1}{4} \times 2 = \frac{1}{2}$$

29. When the output of an OR gate is applied as input to a NOT gate, then the combination acts as a
- (1) NAND gate    (2) NOR gate  
 (3) AND gate    (4) OR gate

**Answer (2)**

**Sol.** When the output of an OR gate is applied as input to a NOT gate, then the combination acts as NOR gate.



34. Some energy levels of a molecule are shown in the figure with their wavelengths of transitions. Then:

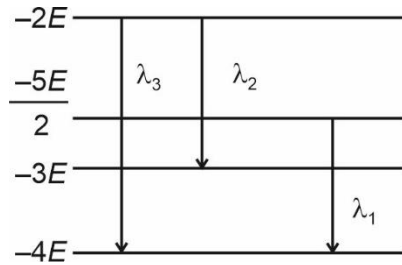

- (1)  $\lambda_3 > \lambda_2, \lambda_1 = 2\lambda_2$
- (2)  $\lambda_3 > \lambda_2, \lambda_1 = 4\lambda_2$
- (3)  $\lambda_1 > \lambda_2, \lambda_2 = 2\lambda_3$
- (4)  $\lambda_2 > \lambda_1, \lambda_2 = 2\lambda_3$

**Answer (4)**

**Sol.** 
$$h \frac{c}{\lambda_1} = \frac{-5E}{2} + 4E = \frac{3}{2}E \quad \dots(1)$$

$$h \frac{c}{\lambda_2} = -2E + 3E = E \quad \dots(2)$$

$$h \frac{c}{\lambda_3} = -2E + 4E = 2E \quad \dots(3)$$

Comparing (2) and (3)

$$\frac{1}{\lambda_3} = \frac{2}{\lambda_2} \quad \lambda_2 = 2\lambda_3$$

Comparing (1) and (2)

$$3\lambda_1 = 2\lambda_2 \quad \lambda_1 < \lambda_2$$

35. A box of mass 5 kg is pulled by a cord, up along a frictionless plane inclined at  $30^\circ$  with the horizontal. The tension in the cord is 30 N. The acceleration of the box is (Take  $g = 10 \text{ m s}^{-2}$ )

- (1)  $2 \text{ m s}^{-2}$
- (2) Zero
- (3)  $0.1 \text{ m s}^{-2}$
- (4)  $1 \text{ m s}^{-2}$

**Answer (4)**

**Sol.**  $T - Mg \sin 30^\circ = Ma$

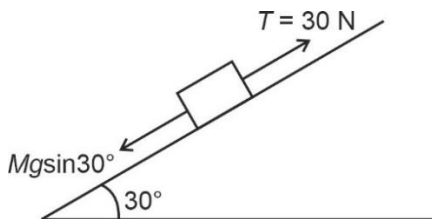

$$30 - 5 \times 10 \times \frac{1}{2} = 5a$$

$$a = 1 \text{ m/s}^2$$

**SECTION-B**

36. If the ratio of relative permeability and relative permittivity of a uniform medium is 1 : 4. The ratio of the magnitudes of electric field intensity ( $E$ ) to the magnetic field intensity ( $H$ ) of an EM wave propagating in that medium is

(Given that  $\sqrt{\frac{\mu_0}{\epsilon_0}} = 120 \pi$ ):

- (1)  $30\pi : 1$
- (2)  $1 : 120\pi$
- (3)  $60\pi : 1$
- (4)  $120\pi : 1$

**Answer (3)**

**Sol.**  $\frac{\mu_r}{\epsilon_r} = \frac{1}{4}$

$$\begin{aligned} \frac{E}{H} &= \frac{E\mu}{B} = v\mu \\ &= \frac{1}{\sqrt{\mu\epsilon}}\mu = \sqrt{\frac{\mu}{\epsilon}} = \sqrt{\frac{\mu_0\mu_r}{\epsilon_0\epsilon_r}} \\ &= \sqrt{\frac{\mu_0}{\epsilon_0}} \sqrt{\frac{\mu_r}{\epsilon_r}} \\ &= 120\pi \left(\frac{1}{2}\right) \\ &= \frac{60\pi}{1} \end{aligned}$$

37. The value of electric potential at a distance of 9 cm from the point charge  $4 \times 10^{-7}$  C is

(Given  $\frac{1}{4\pi\epsilon_0} = 9 \times 10^9 \text{ N m}^2 \text{ C}^{-2}$ ):

- (1)  $4 \times 10^2$  V
- (2) 44.4 V
- (3)  $4.4 \times 10^5$  V
- (4)  $4 \times 10^4$  V

**Answer (4)**

**Sol.**  $V = \frac{kq}{r}$

$$\begin{aligned} &= 9 \times 10^9 \times \frac{4 \times 10^{-7}}{9 \times 10^{-2}} \\ &= 4 \times 10^4 \text{ V} \end{aligned}$$

38. The displacement of a travelling wave  $y = C \sin \frac{2\pi}{\lambda} (at - x)$  where  $t$  is time,  $x$  is distance and  $\lambda$  is the wavelength, all in S.I. units. Then the frequency of the wave is

- (1)  $\frac{2\pi\lambda}{a}$  (2)  $\frac{2\pi a}{\lambda}$   
 (3)  $\frac{\lambda}{a}$  (4)  $\frac{a}{\lambda}$

**Answer (4)**

**Sol.**  $y = c \sin \frac{2\pi}{\lambda} (at - x)$

$$y = c \sin \left( \frac{2\pi}{\lambda} at - \frac{2\pi}{\lambda} x \right)$$

Comparing with  $y = A \sin(\omega t - kx)$

$$\omega = 2\pi f = \frac{2\pi a}{\lambda}$$

$$f = \frac{a}{\lambda}$$

39. An object of mass 100 kg falls from point A to B as shown in figure. The change in its weight, corrected to the nearest integer is ( $R_E$  is the radius of the earth)

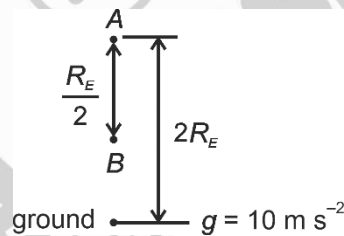

- (1) 49 N  
 (2) 89 N  
 (3) 5 N  
 (4) 10 N

**Answer (1)**

**Sol.**  $Mg' = Mg \frac{R^2}{(R+h)^2}$

At A  $Mg' = Mg \frac{R^2}{(R+2R)^2} = \frac{Mg}{9}$

At B  $Mg' = Mg \frac{R}{\left(R + \frac{3R}{2}\right)^2} = \frac{Mg \cdot 4}{25}$

Change in weight =  $Mg \frac{4}{25} - \frac{Mg}{9} = 49 \text{ N}$

40.

The potential energy of a particle moving along x-direction varies as  $V = \frac{Ax^2}{\sqrt{x+B}}$ . The dimensions of  $\frac{A^2}{B}$  are:

(1)  $[M^{3/2} L^{1/2} T^{-3}]$

(2)  $[M^{1/2} L T^{-3}]$

(3)  $[M^2 L^{1/2} T^{-4}]$

(4)  $[ML^2T^{-4}]$

**Answer (3)**

**Sol.**  $V = \frac{Ax^2}{\sqrt{x+B}}$

As per homogeneous rule  $B = \sqrt{L}$

$$ML^2T^{-2} = \frac{AL^2}{L^{1/2}}$$

$$A = ML^{1/2}T^{-2}$$

$$\frac{A^2}{B} = \frac{M^2LT^{-4}}{L^{1/2}} = M^2L^{1/2}T^{-4}$$

41.

The two-dimensional motion of a particle, described by  $\vec{r} = (\hat{i} + 2\hat{j}) A \cos \omega t$  is a/an:

- A. parabolic path
- B. elliptical path
- C. periodic motion
- D. simple harmonic motion

Choose the correct answer from the options given below:

- (1) B, C and D only
- (2) A, B and C only
- (3) A, C and D only
- (4) C and D only

**Answer (4)**

**Sol.**  $\vec{r} = (\hat{i} + 2\hat{j}) A \cos \omega t$

$$x = A \cos \omega t$$

$$y = 2A \cos \omega t$$

$$y = 2x$$

The path is straight line.

The motion is SHM and periodic as

$$\frac{d\vec{r}}{dt} = -(\hat{i} + 2\hat{j})\omega A \sin \omega t$$

$$\frac{d^2\vec{r}}{dt^2} = -(\hat{i} + 2\hat{j})\omega^2 A \cos \omega t$$

$$\vec{a} = -\omega^2 \vec{r}$$



42. A beam of unpolarized light of intensity  $I_0$  is passed through a polaroid  $A$ , then through another polaroid  $B$ , oriented at  $60^\circ$  and finally through another polaroid  $C$ , oriented at  $45^\circ$  relative to  $B$  as shown. The intensity of emergent light is:

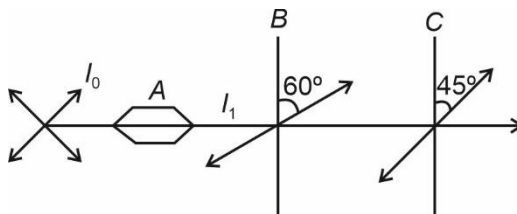

- (1)  $\frac{I_0}{16}$   
 (2)  $\frac{I_0}{4}$   
 (3)  $\frac{I_0}{2}$   
 (4)  $\frac{I_0}{32}$

**Answer (1)**

**Sol.**  $I_1 = \frac{I_0}{2}$

$$I_B = (I_1) \cos^2 60^\circ$$

$$= \frac{I_0}{2} \left(\frac{1}{2}\right)^2 = \frac{I_0}{8}$$

$$I_C = I_B \cos^2 45^\circ$$

$$= \frac{I_0}{8} \times \left(\frac{1}{\sqrt{2}}\right)^2 = \frac{I_0}{16}$$

43. Select the correct statements among the following :
- A. Slow neutrons can cause fission in  ${}^{235}_{92}\text{U}$  than fast neutrons.  
 B.  $\alpha$ -rays are Helium nuclei.  
 C.  $\beta$ -rays are fast moving electrons or positrons.  
 D.  $\gamma$ -rays are electromagnetic radiations of wavelengths larger than X-rays.

Choose the **most appropriate** answer from the options given below :

- (1) A, B and C only  
 (2) A, B and D only  
 (3) A and B only  
 (4) C and D only

**Answer (1)**

- Sol.** (A) Slow neutron can cause fission in  ${}^{235}_{92}\text{U}$  than fast neutrons because fast neutrons are too quick so they scatter of atoms instead of being captured by them
- (B)  $\alpha$ -rays are Helium nuclei, is a true statement
- (C)  $\beta$ -rays are generated when neutron is converted into proton by releasing electron or proton is converted into neutron by releasing positron.
- (D)  $\gamma$ -rays have higher energies as compared to X-rays. So they have smaller wavelength as compared to X-rays.

44. Let  $\omega_1$ ,  $\omega_2$  and  $\omega_3$  be the angular speed of the second hand, minute hand and hour hand of a smoothly running analog clock, respectively. If  $x_1$ ,  $x_2$  and  $x_3$  are their respective angular distances in 1 minute then the factor which remains constant ( $k$ ) is

- (1)  $\frac{\omega_1}{x_1} = \frac{\omega_2}{x_2} = \frac{\omega_3}{x_3} = k$
- (2)  $\omega_1 x_1 = \omega_2 x_2 = \omega_3 x_3 = k$
- (3)  $\omega_1 x_1^2 = \omega_2 x_2^2 = \omega_3 x_3^2 = k$
- (4)  $\omega_1^2 x_1 = \omega_2^2 x_2 = \omega_3^2 x_3 = k$

**Answer (1)**

**Sol.**  $\omega_1 = \frac{2\pi}{60}$ ;  $x_1 = \frac{2\pi}{60} \times 60 = 2\pi$

$\omega_2 = \frac{2\pi}{3600}$ ;  $x_2 = \frac{2\pi}{3600} \times 60 = \frac{2\pi}{60}$

$\omega_3 = \frac{2\pi}{3600 \times 12}$ ;  $x_3 = \frac{2\pi}{3600 \times 12} \times 60 = \frac{2\pi}{720}$

$\frac{\omega_1}{x_1} = \frac{\omega_2}{x_2} = \frac{\omega_3}{x_3} = \frac{1}{60} = k$

45. The magnetic moment of an iron bar is  $M$ . It is now bent in such a way that it forms an arc section of a circle subtending an angle of  $60^\circ$  at the centre. The magnetic moment of this arc section is

- (1)  $\frac{3M}{\pi}$
- (2)  $\frac{4M}{\pi}$
- (3)  $\frac{M}{\pi}$
- (4)  $\frac{2M}{\pi}$

**Answer (1)**

**Sol.**  $M = m \cdot L$

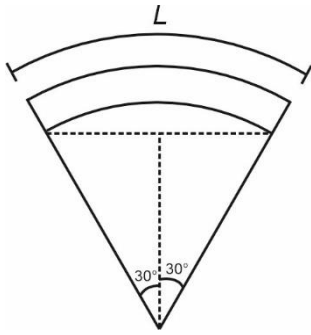

$$R\theta = L$$

$$\frac{R\pi}{3} = L$$

$$R = \frac{3L}{\pi}$$

$$M = m(2R)\sin 30^\circ$$

$$= m(2) \frac{3L}{\pi} \times \frac{1}{2} = \frac{3}{\pi} mL = \frac{3M}{\pi}$$

46. The given circuit shows a uniform straight wire  $AB$  of 40 cm length fixed at both ends. In order to get zero reading in the galvanometer  $G$ , the free end of  $J$  is to be placed from  $B$  at:

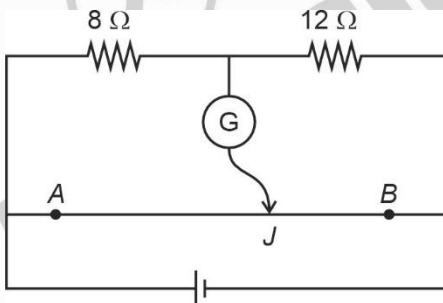

- (1) 32 cm
- (2) 8 cm
- (3) 16 cm
- (4) 24 cm

**Answer (4)**

**Sol.**  $\frac{8}{x} = \frac{12}{40-x}$

$$\frac{2}{x} = \frac{3}{40-x}$$

$$80 - 2x = 3x$$

$$16 = x$$

from B

$$= 40 - 16 = 24 \text{ cm}$$

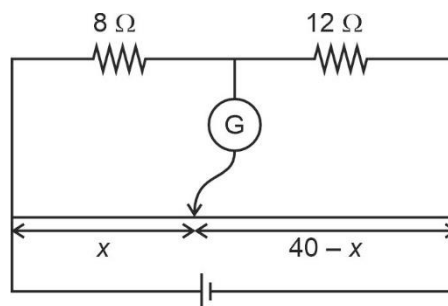

47. According to the law of equipartition of energy, the number of vibrational modes of a polyatomic gas of constant  $\gamma = \frac{C_p}{C_v}$  is ( $C_p$  where  $C_v$  are the specific heat capacities of the gas at constant pressure and constant volume, respectively):

(1)  $\frac{4+3\gamma}{\gamma-1}$

(2)  $\frac{3+4\gamma}{\gamma-1}$

(3)  $\frac{4-3\gamma}{\gamma-1}$

(4)  $\frac{3-4\gamma}{\gamma-1}$

**Answer (3)**

**Sol.** A polygamic gas has 3 translational, 3 rotational and  $f$  vibration modes

$$U = \frac{3}{2}k_B T + \frac{3}{2}k_B T + f k_B T$$

$$U = (3 + f)k_B T$$

$$C_v = (3 + f)R$$

$$C_p = (4 + f)R$$

$$\frac{C_p}{C_v} = \frac{4+f}{3+f} = \gamma$$

$$4 + f = 3\gamma + f\gamma$$

$$4 - 3\gamma = f(\gamma - 1) \Rightarrow f = \frac{4-3\gamma}{\gamma-1}$$

48. The output  $Y$  for the inputs  $A$  and  $B$  of the given logic circuit is :

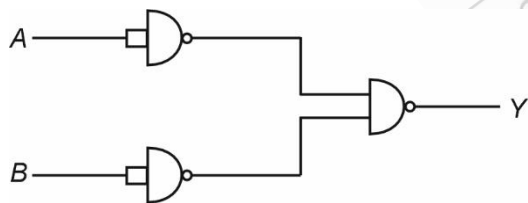

(1)  $A \cdot B$

(2)  $\bar{A} \cdot \bar{B}$

(3)  $A + B$

(4)  $\bar{A} + \bar{B}$

**Answer (3)**

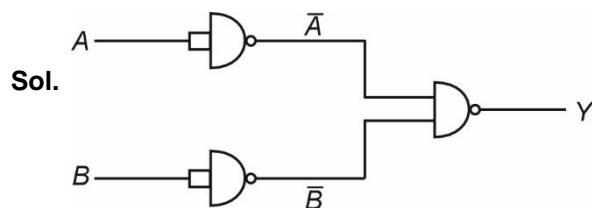

$$Y = \overline{\bar{A}\bar{B}} = A + B$$

49. The amplitude of the charge oscillating in a circuit decreases exponentially as  $Q = Q_0 e^{-Rt/2L}$ , where  $Q_0$  is the charge at  $t = 0$  s. The time at which charge amplitude decreases to  $0.50 Q_0$  is nearly:

[Given that  $R = 1.5 \Omega$ ,  $L = 12$  mH,  $\ln(2) = 0.693$ ]

- (1) 19.01 ms (2) 11.09 ms  
(3) 19.01 s (4) 11.09 s

**Answer (2)**

**Sol.** Given  $Q = Q_0 e^{-Rt/2L}$

$R = 1.5 \Omega$ ,  $L = 12$  mH,  $\ln(2) = 0.693$

$Q = 0.5Q_0$ ,  $t = ?$

$0.5Q_0 = Q_0 e^{-Rt/2L}$

$$\Rightarrow \frac{1}{2} = e^{-Rt/2L}$$

Taking log on both sides

$$\ln\left(\frac{1}{2}\right) = \ln e^{-Rt/2L}$$

$$\Rightarrow \ln 2 = \frac{Rt}{2L}$$

$$t = \frac{2L \ln 2}{R} = \frac{2 \times 12 \times 10^{-3} \times 0.693}{1.5}$$

$t = 11.09$  ms

50. The steady state current in the circuit shown below is :

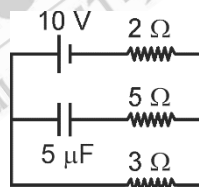

- (1) 0.67 A (2) 1.5 A  
(3) 2 A (4) 1 A

**Answer (3)**

**Sol.** At steady state, capacitor will be completely charged and will not allow current to pass through it. The simplified circuit will be :

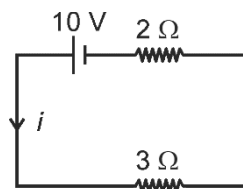

$$i = \frac{V}{R} \Rightarrow i = \frac{10}{2+3} = 2 \text{ A}$$

**CHEMISTRY**

**SECTION-A**

51. The **correct** decreasing order of atomic radii (pm) of Li, Be, B and C is

- (1)  $\text{Be} > \text{Li} > \text{B} > \text{C}$
- (2)  $\text{Li} > \text{Be} > \text{B} > \text{C}$
- (3)  $\text{C} > \text{B} > \text{Be} > \text{Li}$
- (4)  $\text{Li} > \text{C} > \text{Be} > \text{B}$

**Answer (2)**

**Sol.** As the atomic number in a period increases, the effective nuclear charge also increases hence, atomic radii along the period decreases.

Correct order of atomic radii

$\text{Li} > \text{Be} > \text{B} > \text{C}$

52. Following data is for a reaction between reactants A and B :

Rate $\text{mol L}^{-1} \text{s}^{-1}$	[A]	[B]
$2 \times 10^{-3}$	0.1 M	0.1 M
$4 \times 10^{-3}$	0.2 M	0.1 M
$1.6 \times 10^{-2}$	0.2 M	0.2 M

The order of the reaction with respect to A and B, respectively, are

- (1) 1, 0
- (2) 0, 1
- (3) 1, 2
- (4) 2, 1

**Answer (3)**

**Sol.** Let the rate equation is

$$\text{Rate} = k[\text{A}]^x[\text{B}]^y$$

Therefore, we can write

$$2 \times 10^{-3} = k[0.1]^x[0.1]^y \quad \dots(i)$$

$$4 \times 10^{-3} = k[0.2]^x[0.1]^y \quad \dots(ii)$$

$$1.6 \times 10^{-2} = k[0.2]^x[0.2]^y \quad \dots(iii)$$

(ii)  $\div$  (i);

$$\frac{4 \times 10^{-3}}{2 \times 10^{-3}} = \frac{k[0.2]^x[0.1]^y}{k[0.1]^x[0.1]^y}$$

$$\Rightarrow \frac{2}{1} = \frac{(0.2)^x}{(0.1)^x} = \left(\frac{2}{1}\right)^x$$

$$\therefore x = 1$$

(ii)  $\div$  (iii);

$$\frac{4 \times 10^{-3}}{1.6 \times 10^{-2}} = \frac{k[0.2]^x [0.1]^y}{k[0.2]^x [0.2]^y}$$

$$\Rightarrow \frac{1}{4} = \frac{(0.1)^y}{(0.2)^y} = \left(\frac{1}{2}\right)^y$$

$$\therefore y = 2$$

$$\therefore \text{Rate} = k[A]^1[B]^2$$

First order with respect to A while second order with respect to B.

53. Given below are two statements:

**Statement I:** Propene on treatment with diborane gives an addition product with the formula  $((\text{CH}_3)_2 - \text{CH})_3\text{B}$ .

**Statement II:** Oxidation of  $((\text{CH}_3)_2 - \text{CH})_3\text{B}$  with hydrogen peroxide in presence of NaOH gives propan-2-ol.

In the light of the above statements, choose the **most appropriate** answer from the options given below:

- (1) **Statement I** is correct but **Statement II** is incorrect
- (2) **Statement I** is incorrect but **Statement II** is correct
- (3) Both **Statement I** and **Statement II** are correct
- (4) Both **Statement I** and **Statement II** are incorrect

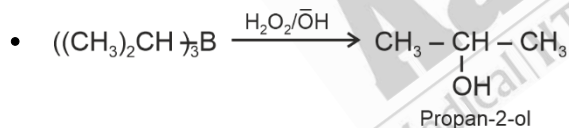
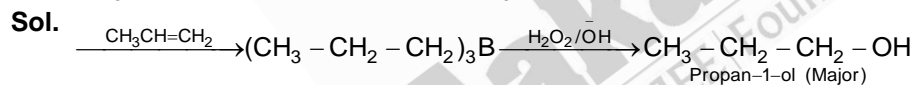
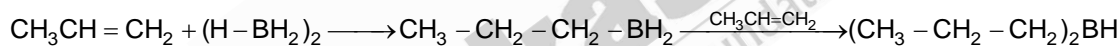
**Answer (2)**

Statement I is incorrect but Statement II is correct.

54. Baeyer's reagent is :

- (1) Acidic potassium permanganate solution
- (2) Acidic potassium dichromate solution
- (3) Cold, dilute, aqueous solution of potassium permanganate
- (4) Hot, concentrated solution of potassium permanganate

**Answer (3)****Sol.** Baeyer's reagent is cold, dilute, aqueous solution of potassium permanganate

55. Which of the following molecules has "NON ZERO" dipole moment value?

- |                    |                   |
|--------------------|-------------------|
| (1) $\text{CCl}_4$ | (2) $\text{HI}$   |
| (3) $\text{CO}_2$  | (4) $\text{BF}_3$ |

**Answer (2)**

**Sol.** Dipole moment of a molecule depends both on shape and bond dipole.

Molecule	Shape	$\mu$ (Debye)
$\text{CCl}_4$		0
$\text{HI}$	$\text{H} - \text{I}$	0.38
$\text{CO}_2$	$\text{O} = \text{C} = \text{O}$	0
$\text{BF}_3$		0

56. The major product X formed in the following reaction sequence is:

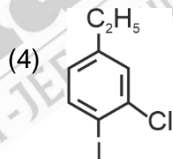
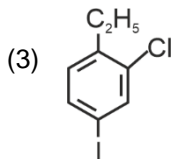
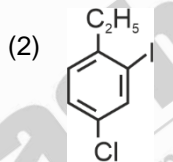
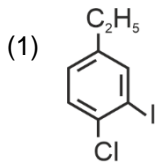
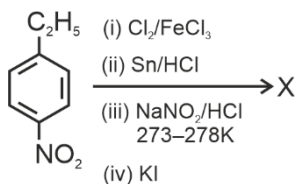

**Answer (3)**

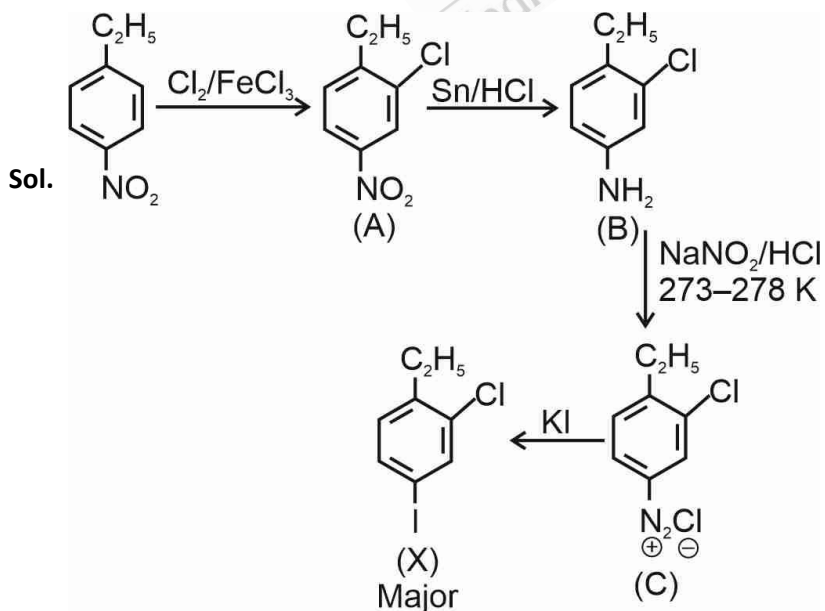



57. Which indicator is used in the titration of sodium hydroxide against oxalic acid and what is the colour change at the end point?
- (1) Phenolphthalein, pink to yellow
  - (2) Alkaline  $\text{KMnO}_4$ , colourless to pink
  - (3) Phenolphthalein, colourless to pink
  - (4) Methyl orange, yellow to pinkish red colour

**Answer (3)**

**Sol.** For weak acid and strong base titration, phenolphthalein is used as indicator. In acidic medium phenolphthalein is colourless while in alkaline medium it is pink in colour.

58. Match List-I with List-II :

	<b>List-I (Atom/Molecule)</b>		<b>List-II (Property)</b>
A.	Nitrogen atom	I.	Paramagnetic
B.	Fluorine molecule	II.	Most reactive element in group 18
C.	Oxygen molecule	III.	Element with highest ionisation enthalpy in group 15
D.	Xenon atom	IV.	Strongest oxidising agent

Identify the **correct** answer from the options given below :

- (1) A-III, B-I, C-IV, D-II
- (2) A-I, B-IV, C-III, D-II
- (3) A-II, B-IV, C-I, D-III
- (4) A-III, B-IV, C-I, D-II

**Answer (4)**

**Sol.**

<b>(Atom/Molecule)</b>	<b>(Property)</b>
Nitrogen atom	Element with highest ionisation enthalpy in group 15
Fluorine molecule	Strongest oxidising agent
Oxygen molecule	Paramagnetic in nature
Xenon atom	Most reactive element in group 18

The correct match is A-III, B-IV, C-I, D-II

59. From the following select the one which is **not** an example of corrosion.
- (1) Rusting of iron object
  - (2) Production of hydrogen by electrolysis of water
  - (3) Tarnishing of silver
  - (4) Development of green coating on copper and bronze ornaments

**Answer (2)**



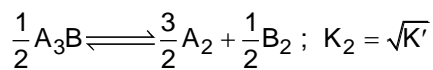
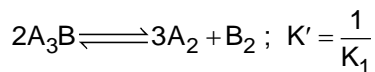
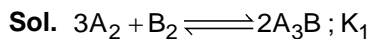

$$K_2 = \sqrt{K'}$$

$$= \frac{1}{\sqrt{K_1}}$$

62. Arrange the following compounds in increasing order of their solubilities in chloroform:

NaCl, CH<sub>3</sub>OH, cyclohexane, CH<sub>3</sub>CN

- (1) NaCl < CH<sub>3</sub>CN < CH<sub>3</sub>OH < Cyclohexane      (2) CH<sub>3</sub>OH < CH<sub>3</sub>CN < NaCl < Cyclohexane  
 (3) NaCl < CH<sub>3</sub>OH < CH<sub>3</sub>CN < Cyclohexane      (4) Cyclohexane < CH<sub>3</sub>CN < CH<sub>3</sub>OH < NaCl

**Answer (1)**

**Sol.** Since CHCl<sub>3</sub> is an organic solvent so, covalent (non-polar) compounds will be more soluble in it. As the dipole moment of solute increases, solubility in chloroform decreases. Hence increasing order of solubility.

NaCl < CH<sub>3</sub>CN < CH<sub>3</sub>OH < Cyclohexane

63. Identify the **incorrect** statement about PCl<sub>5</sub>.

- (1) PCl<sub>5</sub> possesses two different Cl – P – Cl bond angles  
 (2) All five P – Cl bonds are identical in length  
 (3) PCl<sub>5</sub> exhibits *sp*<sup>3</sup>*d* hybridisation  
 (4) PCl<sub>5</sub> consists of five P – Cl (sigma) bonds

**Answer (2)**

**Sol.**

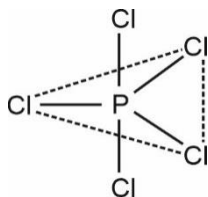

It is *sp*<sup>3</sup>*d* hybridised with axial to equatorial angle of 90° and equatorial bond angles of 120°. It has five P – Cl sigma bonds.

Axial bonds are longer than equatorial bonds.

64. Choose the correct statement for the work done in the expansion and heat absorbed or released when 5 litres of an ideal gas at 10 atmospheric pressure isothermally expands into vacuum until volume is 15 litres :

- (1) Both the heat and work done will be greater than zero  
 (2) Heat absorbed will be less than zero and work done will be positive  
 (3) Work done will be zero and heat will also be zero  
 (4) Work done will be greater than zero and heat will remain zero

**Answer (3)**

**Sol.** Since it is isothermal,  $\Delta T = 0$

$$\Delta U = nC_v\Delta T = 0$$

Since expansion is taking place against vacuum

$$P_{\text{ext}} = 0$$

$$W = -P_{\text{ext}}\Delta V = 0$$

From first law of thermodynamics,

$$\Delta U = q + W$$

$$0 = q + 0$$

$$q = 0$$

65. The correct IUPAC name of the compound

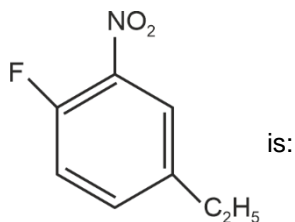

- (1) 4-ethyl-1-fluoro-2-nitrobenzene
- (2) 4-ethyl-1-fluoro-6-nitrobenzene
- (3) 3-ethyl-6-fluoro-1-nitrobenzene
- (4) 1-ethyl-4-fluoro-3-nitrobenzene

**Answer (1)**

**Sol.**

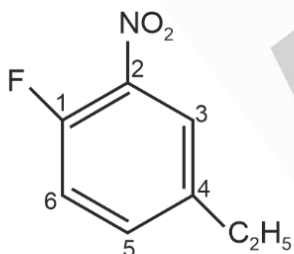

4-ethyl-1-fluoro-2-nitrobenzene

66. Which of the following set of ions act as oxidising agents?

- (1)  $\text{Ce}^{4+}$  and  $\text{Tb}^{4+}$
- (2)  $\text{La}^{3+}$  and  $\text{Lu}^{3+}$
- (3)  $\text{Eu}^{2+}$  and  $\text{Yb}^{2+}$
- (4)  $\text{Eu}^{2+}$  and  $\text{Tb}^{4+}$

**Answer (1)**

**Sol.** Most stable oxidation state of lanthanoids is +3

$\text{Ce}^{4+}$  and  $\text{Tb}^{4+}$  will get reduced easily and will be good oxidising agents.



**Sol.** Molarity,  $M = \frac{w_2 \times 1000}{M_2 \times (V)}$

$w_2$  = Amount of glucose

Given molarity =  $\frac{M}{20}$

$$\frac{1}{20} = \frac{w_2 \times 1000}{180 \times 250}$$

$$w_2 = \frac{180 \times 250}{20 \times 1000}$$

$$= 2.25 \text{ g}$$

71. Identify the **incorrect** statement from the following :

- (1) The acidic strength of HX (X = F, Cl, Br and I) follows the order : HF > HCl > HBr > HI.
- (2) Fluorine exhibits –1 oxidation state whereas other halogens exhibit +1, +3, +5 and +7 oxidation states also.
- (3) The enthalpy of dissociation of F<sub>2</sub> is smaller than that of Cl<sub>2</sub>.
- (4) Fluorine is stronger oxidising agent than chlorine.

**Answer (1)**

**Sol.** The acidic strength of HX follows the order HF < HCl < HBr < HI

This is because bond enthalpy of hydrides of group 17 decreases down the group.

72. For the reaction in equilibrium

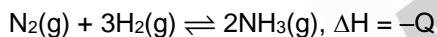

Reaction is favoured in forward direction by:

- (1) use of catalyst
- (2) decreasing concentration of N<sub>2</sub>
- (3) low pressure, high temperature and high concentration of ammonia
- (4) high pressure, low temperature and higher concentration of H<sub>2</sub>

**Answer (4)**

**Sol.**  $\text{N}_2(\text{g}) + 3\text{H}_2(\text{g}) \rightleftharpoons 2\text{NH}_3(\text{g}), \Delta H = -Q$

According to Le Chatelier's principle.

- Exothermic reactions are favoured at low temperature.
- Increase in pressure shifts the reaction in direction having lesser number of moles. Hence, the given reaction shifts forward on increasing pressure.
- Increasing the concentration of reactants shifts the reaction in forward direction. So high concentration of H<sub>2</sub> shifts reaction in forward direction.

73. The major product D formed in the following reaction sequence is:

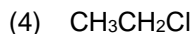
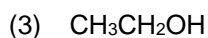
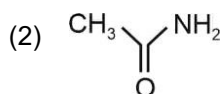
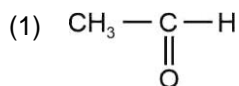
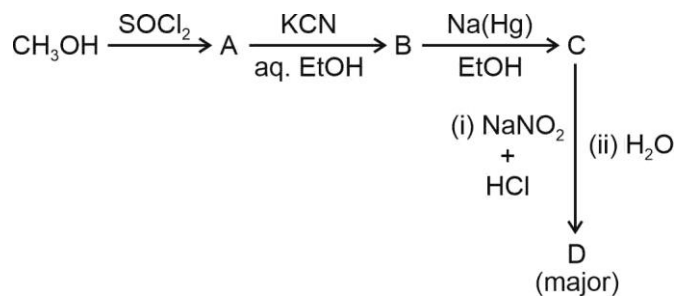

**Answer (3)**

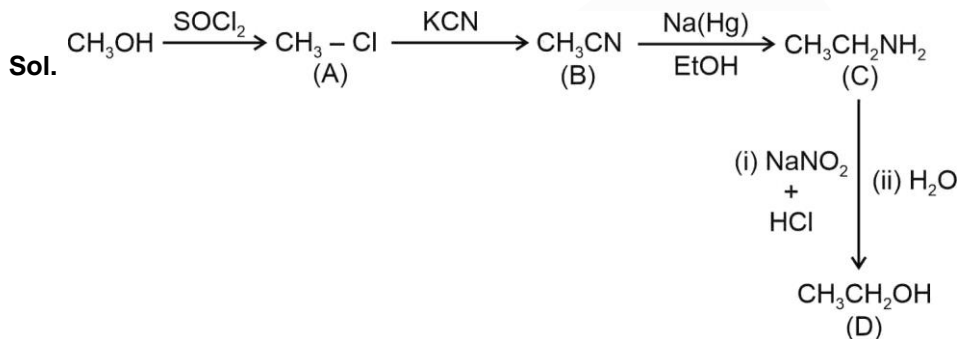

74. Match List-I with List-II:

	List-I (Block/group in periodic table)		List-II (Element)
A.	Lanthanoid	I.	Ce
B.	d-block element	II.	As
C.	p-block element	III.	Cs
D.	s-block element	IV.	Mn

Choose the **correct** answer from the options given below:

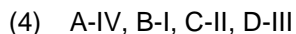
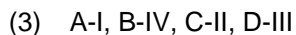
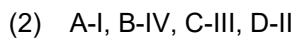
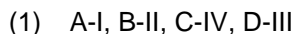

**Answer (3)**

Sol. Element		Block/group in periodic table
Ce (Z = 58)	→	Lanthanoid
As (Z = 33)	→	p-block element
Cs (Z = 55)	→	s-block element
Mn (Z = 25)	→	d-block element
A-I, B-IV, C-II, D-III		

75. Which of the following is **not** an ambidentate ligand?

- (1)  $C_2O_4^{2-}$  (2)  $SCN^-$   
 (3)  $NO_2^-$  (4)  $CN^-$

**Answer (1)**

**Sol.** Ambidentate ligands are those ligands which have two different donor atoms and either of two donor atom is attached to the metal during complex formation.

(1)  $COO^- \rightarrow M$  has only one donor site through 'O'. So, it is not ambidentate.

(2)  $SCN \rightarrow M$

$NCS \rightarrow M$

(Ambidentate)

(3)  $M \leftarrow N = O$

$M \leftarrow O - N = O$

(Ambidentate)

(4)  $M \leftarrow CN$

$M \leftarrow NC$

(Ambidentate)

76. The quantum numbers of four electrons are given below :

I.  $n = 4; l = 2; m_l = -2; s = -\frac{1}{2}$

II.  $n = 3; l = 2; m_l = 1; s = +\frac{1}{2}$

III.  $n = 4; l = 1; m_l = 0; s = +\frac{1}{2}$

IV.  $n = 3; l = 1; m_l = -1; s = +\frac{1}{2}$

The **correct** decreasing order of energy of these electrons is

- (1)  $IV > II > III > I$  (2)  $I > III > II > IV$   
 (3)  $III > I > II > IV$  (4)  $I > II > III > IV$

**Answer (2)**



**Sol.** (I)  $n = 4, l = 2, m_l = -2, s = -\frac{1}{2}$ ; represents  $4d (n + l = 6)$

(II)  $n = 3, l = 2, m_l = 1, s = +\frac{1}{2}$ ; represents  $3d (n + l = 5)$

(III)  $n = 4, l = 1, m_l = 0, s = +\frac{1}{2}$ ; represents  $4p (n + l = 5)$

(IV)  $n = 3, l = 1, m_l = -1, s = +\frac{1}{2}$ ; represents  $3p (n + l = 4)$

Order of energy depends on the  $(n + l)$ , greater is the  $(n + l)$  value greater is the energy, if  $(n + l)$  is same, then it depends on  $n$ ; if 'n' is more, energy is more.

**Step-1 :** According to  $(n + l)$

Energy = (I) > (II) = (III) > (IV)

**Step-2 :** If  $n \uparrow$ , then energy increases

Energy = (I) > (III) > (II) > (IV)

77. The major product C in the below mentioned reaction is:

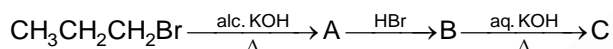

(1) Propan-1-ol

(2) Propan-2-ol

(3) Propane

(4) Propyne

**Answer (2)**

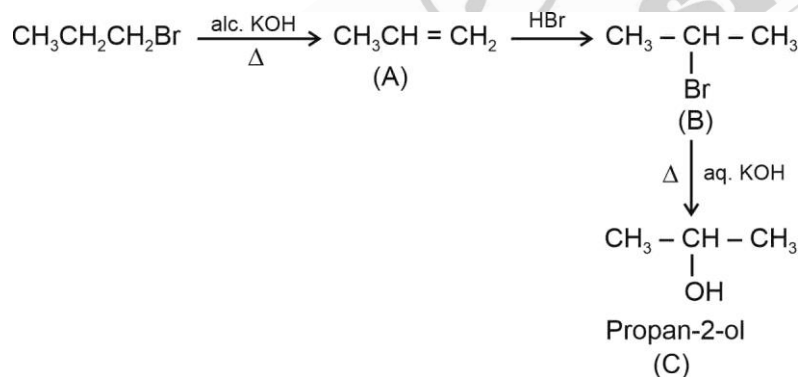

**Sol.**

78. The compound that does not undergo Friedel-Crafts alkylation reaction but gives a positive carbylamine test is :

(1) Aniline

(2) Pyridine

(3) N-methylaniline

(4) Triethylamine

**Answer (1)**

**Sol.** For positive carbylamine test, there must be the presence of primary amine.

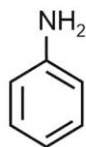

It will not show Friedel Crafts alkylation.  
But gives positive carbylamine test

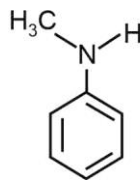
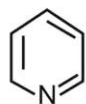

$(\text{C}_2\text{H}_5)_3\text{N}$

These are not primary amines  
Hence, do not give carbylamine test

79. For an endothermic reaction:

- (A)  $q_p$  is negative.
- (B)  $\Delta_r H$  is positive.
- (C)  $\Delta_r H$  is negative.
- (D)  $q_p$  is positive.

Choose the **correct** answer from the options given below:

- (1) B and D
- (2) C and D
- (3) A and B
- (4) A and C

**Answer (1)**

**Sol.** For endothermic reactions,

$\Delta H_r = \text{positive}$  (Heat is absorbed)

$$\Delta H = E_{a(f)} - E_{a(b)}$$

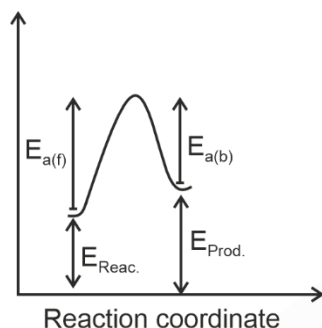

80. 1.0 g of  $H_2$  has same number of molecules as in:

- (1) 14 g of  $N_2$
- (2) 18 g of  $H_2O$
- (3) 16 g of  $CO$
- (4) 28 g of  $N_2$

**Answer (1)**

**Sol.** Number of moles of  $H_2 = \frac{1}{2} = 0.5$

Number of molecules of  $H_2 = 0.5 N_A$ .

(1) Number of moles of  $N_2 = \frac{14}{28} = 0.5$

Number of molecules of  $N_2 = 0.5 N_A$

(2) Number of moles of  $H_2O = \frac{18}{18} = 1$

Number of molecules of  $H_2O = 1 \times N_A = N_A$

(3) Number of moles of  $CO = \frac{16}{28} = \frac{4}{7}$

Number of molecules of  $CO = \frac{4}{7} N_A$

(4) Number of moles of  $N_2 = \frac{28}{28} = 1$

Number of molecules of  $N_2 = 1 \times N_A = N_A$

81. Which of the following plot represents the variation of  $\ln k$  versus  $\frac{1}{T}$  in accordance with Arrhenius equation?

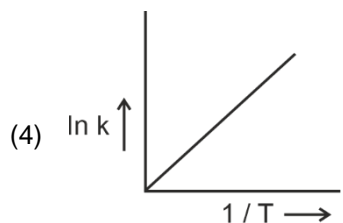
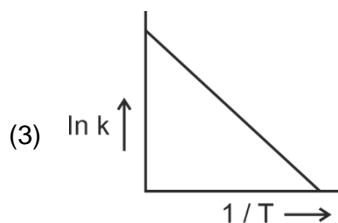
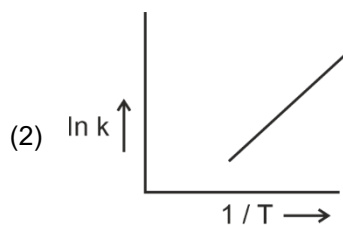
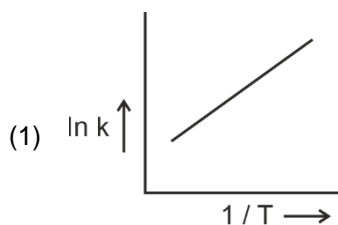

**Answer (3)**

**Sol.** Using Arrhenius equation,

$$k = Ae^{-E_a/RT}$$

$$\ln k = \ln A - \frac{E_a}{RT}$$

$$y = c + mx, \quad \text{slope (m)} = -\frac{E_a}{R}$$

$$\text{Intercept} = \ln A$$

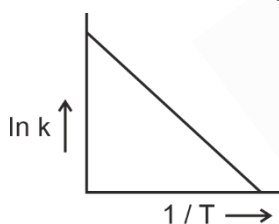

82. A steam volatile organic compound which is immiscible with water has a boiling point of  $250^\circ\text{C}$ . During steam distillation, a mixture of this organic compound and water will boil :
- (1) above  $100^\circ\text{C}$  but below  $250^\circ\text{C}$                       (2) above  $250^\circ\text{C}$   
 (3) at  $250^\circ\text{C}$     (4) close to but below  $100^\circ\text{C}$

**Answer (4)**

**Sol.** If one of the substances in the mixture is water and the other, a water insoluble substance, then the mixture will boil close to but below,  $373\text{ K}$  ( $100^\circ\text{C}$ ).

83. Given below are two statements :

**Statement I :** Glycogen is similar to amylose in its structure.

**Statement II :** Glycogen is found in yeast and fungi also.

In the light of the above statements, choose the **correct** answer from the options given below :

- (1) **Statement I** is true but **Statement II** is false.      (2) **Statement I** is false but **Statement II** is true.  
 (3) Both **Statement I** and **Statement II** are true.      (4) Both **Statement I** and **Statement II** are false.

**Answer (2)**

**Sol.** Glycogen is similar to amylopectin in its structure. Glycogen is also found in yeast and fungi.

So statement I is false but statement II is true.

84. The oxidation states **not** shown by Mn in given reaction is :

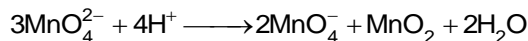

- A. +6
- B. +2
- C. +4
- D. +7
- E. +3

Choose the **most appropriate** answer from the options given below :

- (1) D and E only
- (2) B and D only
- (3) A and B only
- (4) B and E only

**Answer (4)**

**Sol.** In the following reaction

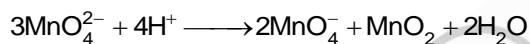

Oxidation state of Mn	Species
+6	$\text{MnO}_4^{2-}$
+7	$\text{MnO}_4^-$
+4	$\text{MnO}_2$

So +2 and +3 oxidation state is not shown by Mn.

85. Given below are two statements:

**Statement I:** The Balmer spectral line for H atom with lowest energy is located at  $\frac{5}{36}R_H \text{ cm}^{-1}$ .

( $R_H$  = Rydberg constant)

**Statement II:** When the temperature of blackbody increases, the maxima of the curve (intensity and wavelength) shifts to shorter wavelength.

In the light of the above statements, choose the **correct** answer from the options given below:

- (1) **Statement I** is true but **Statement II** is false
- (2) **Statement I** is false but **Statement II** is true
- (3) Both **Statement I** and **Statement II** are true
- (4) Both **Statement I** and **Statement II** are false

**Answer (3)**

**Sol.** For Balmer series  $n_1 = 2$

$$n_2 = 3$$

$$\bar{\nu} = \frac{1}{\lambda} = R_H \left[ \frac{1}{n_1^2} - \frac{1}{n_2^2} \right]$$

$$\bar{\nu} = R_H \left[ \frac{1}{4} - \frac{1}{9} \right]$$

$$\bar{\nu} = \frac{5R_H}{36} \text{ cm}^{-1}$$

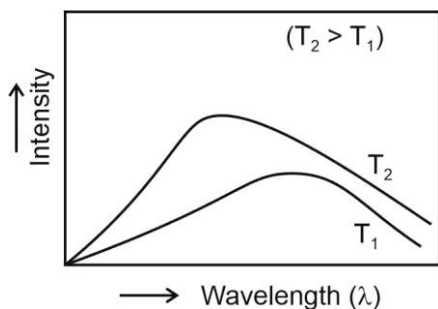

**SECTION-B**

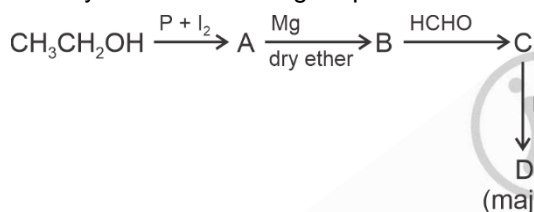
86. Identify D in the following sequence of reactions:

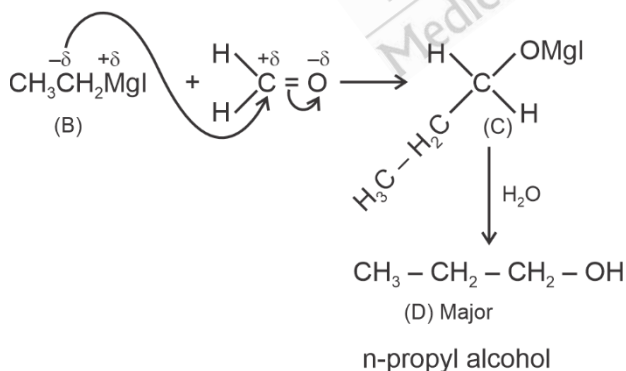
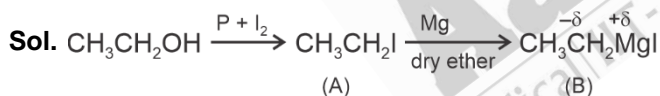

- |                      |                       |
|----------------------|-----------------------|
| (1) n-propyl alcohol | (2) isopropyl alcohol |
| (3) propanal         | (4) propionic acid    |

**Answer (1)**



87. Identify the **incorrect** statement.

- (1)  $\text{PEt}_3$  and  $\text{AsPh}_3$  as ligands can form  $d\pi-d\pi$  bond with transition metals
- (2) The N – N single bond is as strong as the P – P single bond
- (3) Nitrogen has unique ability to form  $p\pi-p\pi$  multiple bonds with nitrogen, carbon and oxygen
- (4) Nitrogen cannot form  $d\pi-p\pi$  bond as other heavier elements of its group

**Answer (2)**

- Sol.**
- $\text{PEt}_3$  and  $\text{AsPh}_3$  as ligands can form  $d\pi-d\pi$  bond with transition metals.
  - The N – N single bond is weaker than the single P – P bond because of high inter-electronic repulsion of the non-bonding electrons.
  - Nitrogen has unique ability to form  $p\pi-p\pi$  multiple bonds with itself, carbon and oxygen.
  - Nitrogen cannot form  $d\pi-p\pi$  bond as other heavier elements of its group.

88. Match List-I with List-II :

List-I (Test/reagent)	List-II (Radical identified)
A. Lake Test	I. $\text{NO}_3^-$
B. Nessler's Reagent	II. $\text{Fe}^{3+}$
C. Potassium sulphocyanide	III. $\text{Al}^{3+}$
D. Brown Ring Test	IV. $\text{NH}_4^+$

Choose the **correct** answer from the options given below :

- (1) A-IV, B-II, C-III, D-I
- (2) A-II, B-IV, C-III, D-I
- (3) A-II, B-III, C-IV, D-I
- (4) A-III, B-IV, C-II, D-I

**Answer (4)**

<b>Sol.</b> Lake test	– $\text{Al}^{3+}$
Nessler's reagent	– $\text{NH}_4^+$
Potassium sulphocyanide	– $\text{Fe}^{3+}$
Brown ring test	– $\text{NO}_3^-$

89. Match List-I with List-II:

	List-I Molecule		List-II Bond enthalpy ( $\text{kJ mol}^{-1}$ )
A.	HCl	I.	435.8
B.	$\text{N}_2$	II.	498
C.	$\text{H}_2$	III.	946.0
D.	$\text{O}_2$	IV.	431.0

Choose the correct answer from the options given below:

- (1) A-III, B-IV, C-I, D-II
- (2) A-IV, B-I, C-III, D-II
- (3) A-IV, B-III, C-II, D-I
- (4) A-IV, B-III, C-I, D-II

**Answer (4)**

Sol.

Molecule	Bond enthalpy (kJ mol <sup>-1</sup> )
HCl	431.0
N <sub>2</sub>	946.0
H <sub>2</sub>	435.8
O <sub>2</sub>	498

90. The standard cell potential of the following cell Zn|Zn<sup>2+</sup>(aq)||Fe<sup>2+</sup>(aq)|Fe is 0.32 V. Calculate the standard Gibbs energy change for the reaction :

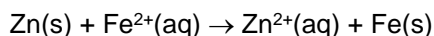

(Given : 1 F = 96487 C)

- (1) -61.75 kJ mol<sup>-1</sup>  
 (2) +5.006 kJ mol<sup>-1</sup>  
 (3) -5.006 kJ mol<sup>-1</sup>  
 (4) +61.75 kJ mol<sup>-1</sup>

**Answer (1)**

**Sol.**  $\Delta_r G^\ominus = -nF E_{\text{cell}}^\ominus$

For the given reaction, n = 2

$$\begin{aligned} \therefore \Delta_r G^\ominus &= -2 \times 96487 \times 0.32 \\ &= -61751.68 \text{ J mol}^{-1} \\ &= -61.751 \text{ kJ mol}^{-1} \end{aligned}$$

91. Match List-I with List-II:

**List-I**  
**Solid salt treated with**  
**dil. H<sub>2</sub>SO<sub>4</sub>**

- A. effervescence of colourless gas  
 B. gas with smell of rotten egg  
 C. gas with pungent smell  
 D. brown fumes

**List-II**  
**Anion detected**

- I. NO<sub>2</sub><sup>-</sup>  
 II. CO<sub>3</sub><sup>2-</sup>  
 III. S<sup>2-</sup>  
 IV. SO<sub>3</sub><sup>2-</sup>

Choose the **correct** answer from the options given below:

- (1) A-II, B-III, C-IV, D-I  
 (2) A-IV, B-III, C-II, D-I  
 (3) A-I, B-II, C-III, D-IV  
 (4) A-II, B-III, C-I, D-IV

**Answer (1)**





94. The following reaction method

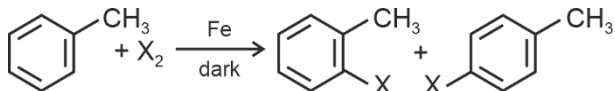

is **not** suitable for the preparation of the corresponding haloarene products, due to high reactivity of halogen, when X is :

- (1) F (2) I  
 (3) Cl (4) Br

**Answer (1)**

**Sol.**

- Aryl chlorides and bromides can easily be prepared by electrophilic substitution of arenes (toluene) with  $\text{Cl}_2$  and  $\text{Br}_2$  respectively in the presence of Lewis acid catalyst (Fe in dark).
  - Reaction with  $\text{I}_2$  is reversible and requires the presence of oxidising agent.
  - Corresponding fluoroarene is not prepared by this method due to high reactivity of fluorine.
- Hence, 'X' is F.

95. The alkane that can be oxidized to the corresponding alcohol by  $\text{KMnO}_4$  as per the equation



is, when:

- (1)  $\text{R}_1 = \text{H}$ ;  $\text{R}_2 = \text{H}$ ;  $\text{R}_3 = \text{H}$  (2)  $\text{R}_1 = \text{CH}_3$ ;  $\text{R}_2 = \text{CH}_3$ ;  $\text{R}_3 = \text{CH}_3$   
 (3)  $\text{R}_1 = \text{CH}_3$ ;  $\text{R}_2 = \text{H}$ ;  $\text{R}_3 = \text{H}$  (4)  $\text{R}_1 = \text{CH}_3$ ;  $\text{R}_2 = \text{CH}_3$ ;  $\text{R}_3 = \text{H}$

**Answer (2)**

**Sol.** Generally alkanes resist oxidation but alkane with tertiary H atom(s) can be oxidised to corresponding alcohols by  $\text{KMnO}_4$

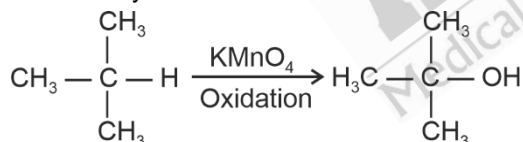

$$\therefore \text{R}_1 \Rightarrow \text{CH}_3 \quad \text{R}_2 \Rightarrow \text{CH}_3 \quad \text{R}_3 \Rightarrow \text{CH}_3$$

96. For the following reaction at 300 K

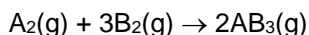

the enthalpy change is +15 kJ, then the internal energy change is :

- (1) 19988.4 J  
 (2) 200 J  
 (3) 1999 J  
 (4) 1.9988 kJ

**Answer (1)**

**Sol.**  $\text{A}_2(\text{g}) + 3\text{B}_2(\text{g}) \rightarrow 2\text{AB}_3(\text{g})$

$$\Delta n_{(\text{g})} = n_{(\text{P})} - n_{(\text{R})}$$

$$= 2 - 3 - 1 = -2$$

$$\Delta H = \Delta U + \Delta n_g RT$$

$$15 \times 1000 = \Delta U - 2 \times 8.314 \times 300$$

$$\Delta U = 15000 + 600 \times 8.314$$

$$= 15000 + 6 \times 831.4$$

$$= 15000 + 4988.4$$

$$\Delta U = 19988.4 \text{ J}$$

97. Rate constants of a reaction at 500 K and 700 K are  $0.04 \text{ s}^{-1}$  and  $0.14 \text{ s}^{-1}$ , respectively; then, activation energy of the reaction is :

(Given:  $\log 3.5 = 0.5441$ ,  $R = 8.31 \text{ J K}^{-1} \text{ mol}^{-1}$ )

(1) 182310 J

(2) 18500 J

(3) 18219 J

(4) 18030 J

**Answer (3)**

**Sol.**  $K = Ae^{-E_a/RT}$

After taking ln both side

$$\ln K = \ln A - \frac{E_a}{RT}$$

$$\ln K_1 = \ln A - \frac{E_a}{RT_1} \text{ at temp. } T_1 \quad \dots(i)$$

$$\ln K_2 = \ln A - \frac{E_a}{RT_2} \text{ at temp. } T_2 \quad \dots(ii)$$

(ii) - (i)

$$\ln K_2 - \ln K_1 = \frac{E_a}{R} \left[ \frac{1}{T_1} - \frac{1}{T_2} \right]$$

$$\ln \frac{K_2}{K_1} = \frac{E_a}{R} \left[ \frac{1}{500} - \frac{1}{700} \right]$$

$$\ln \frac{0.14}{0.04} = \frac{E_a}{R} \left[ \frac{700 - 500}{500 \times 700} \right]$$

$$\ln \frac{14}{4} = \frac{E_a}{R} \left[ \frac{200}{500 \times 700} \right]$$

$$\log 3.5 = \frac{E_a}{2.303 \times R} \left[ \frac{1}{250 \times 7} \right]$$

$$0.5441 = \frac{E_a}{2.303 \times 8.31} \left[ \frac{1}{250 \times 7} \right]$$

$$E_a = 0.5441 \times 8.31 \times 250 \times 7 \times 2.303$$

$$= 0.5441 \times 83.1 \times 25 \times 7 \times 2.303$$

$$= 18222.65$$

$$\approx 18219 \text{ J}$$



**BOTANY**

**SECTION-A**

101. The regions with high level of species richness, high degree of endemism and a loss of 70% of the species and habitat are identified as:

- (1) Natural Reserves
- (2) Sacred Groves
- (3) Biodiversity Hotspots
- (4) Biogeographical Regions

**Answer (3)**

**Sol.** The regions with high level of species richness, high degree of endemism and a loss of most of the species and habitat are identified as Biodiversity hotspots.

102. Which of the following simple tissues are commonly found in the fruit walls of nuts and pulp of pear?

- (1) Sclereids
- (2) Fibres
- (3) Parenchyma
- (4) Collenchyma

**Answer (1)**

**Sol.** Sclereids are commonly found in the hard parts of the plant such as fruit walls of nuts, or they occur in soft parts, *i.e.*, pulp of the fruits, like pear.

103. In a chromosome, there is a specific DNA sequence, responsible for initiating replication. It is called as:

- (1) Recognition sequence
- (2) Cloning site
- (3) Restriction site
- (4) *ori* site

**Answer (4)**

**Sol.** Option (4) is the correct answer because origin of replication (*ori*) is a sequence from where replication starts and any piece of DNA when linked to this sequence can be made to replicate, within the host cells.

Option (1) is incorrect because recognition sequence is a specific palindromic nucleotide sequence in DNA recognised by restriction endonuclease.

Options (2) and (3) are not the answers because cloning site/restriction site is the site on the vector for the use of restriction enzyme and it is similar to recognition site.

104. Given below are two statements:

**Statement I:** When many alleles of a single gene govern a character, it is called polygenic inheritance.

**Statement II:** In Polygenic inheritance, the effect of each allele is additive.

In the light of the above statements, choose the **correct** answer from the options given below.

- (1) Statement I is true but Statement II is false
- (2) Statement I is false but Statement II is true
- (3) Both Statement I and Statement II are true
- (4) Both Statement I and Statement II are false

**Answer (2)**

**Sol.** Polygenic inheritance refers to the inheritance of a trait governed by more than one gene.

In a polygenic trait the phenotype reflects the contribution of each allele *i.e.*, the effect of each allele is additive.

Hence, statement I is incorrect and statement II is correct.

105. Which of the following are required for the light reaction of Photosynthesis?

- |                         |                 |
|-------------------------|-----------------|
| A. $\text{CO}_2$        | B. $\text{O}_2$ |
| C. $\text{H}_2\text{O}$ | D. Chlorophyll  |
| E. Light                |                 |

Choose the **correct** answer from the options given below:

- (1) A, C, D and E only
- (2) C, D and E only
- (3) A and B only
- (4) A, C and E only

**Answer (2)**

**Sol.** For the process of light reaction, water, light and chlorophyll are required.

$\text{CO}_2$  is used during the second stage of photosynthesis *i.e.* dark reaction.

Oxygen is a product of light reaction formed by photolysis of water.

106. Match **List-I** with **List-II**:

- | <b>List-I</b>    | <b>List-II</b>                                     |
|------------------|--|
| A. Fleming       | I. Disc shaped sacs or cisternae near cell nucleus |
| B. Robert Brown  | II. Chromatin                                      |
| C. George Palade | III. Ribosomes                                     |
| D. Camillo Golgi | IV. Nucleus  |

Choose the **correct** answer from the options given below:

- (1) A-II, B-IV, C-III, D-I
- (2) A-II, B-III, C-I, D-IV
- (3) A-I, B-II, C-III, D-IV
- (4) A-IV, B-II, C-III, D-I

**Answer (1)**

- Sol.**
- Nucleus as a cell organelle was first described by Robert Brown as early as 1831.
  - Later the material of the nucleus stained by the basic dyes was given the name chromatin by Flemming.
  - Ribosomes are the granular structure first observed under the microscope as dense particle by George Palade.
  - Camillo Golgi first observed densely stained reticular structure near the nucleus. It consist of many disc shaped sac or cisternae.

Hence, A-II, B-IV, C-III, D-I is correct.

107. Match **List-I** with **List-II**:

<b>List-I</b>	<b>List-II</b>
<b>Type of Inheritance</b>	<b>Example</b>
A. Incomplete dominance	I. Blood groups in human
B. Co-dominance	II. Flower colour in <i>Antirrhinum</i>
C. Pleiotropy	III. Skin colour in human
D. Polygenic inheritance	IV. Phenylketonuria

Choose the **correct** answer from the options given below:

- (1) A-III, B-IV, C-II, D-I
- (2) A-II, B-I, C-IV, D-III
- (3) A-II, B-III, C-I, D-IV
- (4) A-IV, B-I, C-III, D-II

**Answer (2)**

- Sol.**
- Flower colour in *Antirrhinum* is a good example of incomplete dominance.
  - Blood group in humans is an example of co-dominance where  $F_1$  generation resembles both the parents.
  - Phenylketonuria is an example of Pleiotropy.
  - Skin colour in human shows polygenic inheritance.

Hence, A-II, B-I, C-IV, D-III is correct.

108. Which part of the ovule stores reserve food materials?

- (1) Nucellus
- (2) Integument
- (3) Placenta
- (4) Funicle

**Answer (1)**

**Sol.** Nucellus is a mass of cell enclosed within the integument and it has abundant food reserves.

Each ovule has one or more protective layer called integuments.

The ovule is a small structure attached to the placenta by means of a stalk called funicle.

109. Which one of the following is **not** found in Gymnosperms?

- (1) Sieve cells
- (2) Albuminous cells
- (3) Tracheids
- (4) Vessels

**Answer (4)**

**Sol.** Gymnosperm lack vessels in their xylem. In place of companion cells they have albuminous cells. They lack sieve tube but have sieve cells.

110. Which one of the following is **not** included under *in-situ* conservation?

- (1) Wild-life sanctuary
- (2) Botanical garden
- (3) Biosphere reserve
- (4) National park

**Answer (2)**

**Sol.** Botanical garden is an *ex-situ* conservation strategy of biodiversity.

Wild-life Sanctuary, Biosphere Reserve and National Parks are *in-situ* conservation strategy of biodiversity.

111. Given below are two statements:

**Statement I :** The Indian Government has set up GEAC, which will make decisions regarding the validity of GM research.

**Statement II :** Biopiracy is the term used to refer to the use of bio-resources by native people.

In the light of the above statements, choose the **correct** answer from the options given below :

- (1) **Statement I** is true but **Statement II** is false
- (2) **Statement I** is false but **Statement II** is true
- (3) Both **Statement I** and **Statement II** are true
- (4) Both **Statement I** and **Statement II** are false

**Answer (1)**

**Sol.** Option (1) is the correct answer because Indian Government has set up organisations such as GEAC (Genetic Engineering Approval Committee), which will make decisions regarding the validity of GM research and the safety of introducing GM-organisms for public services and Biopiracy is used to refer to the use of bioresources by multinational companies and other organisations without proper authorisation from the countries and people concerned without compensatory payment, thus statement I is true but statement II is false.

112. Pollen grains remain preserved as fossils due to the presence of :

- (1) Epidermal layer
- (2) Tapetum
- (3) Exine layer
- (4) Intine layer

**Answer (3)**

**Sol.** Pollen grains are well-preserved as fossils because of the presence of sporopollenin, which is found in the outer layer of pollen, *i.e.*, exine.

113. Identify the **incorrect** pair :

- (1) Sphenopsida – *Adiantum*
- (2) Pteropsida – *Dryopteris*
- (3) Psilopsida – *Psilotum*
- (4) Lycopsida – *Selaginella*

**Answer (1)**

**Sol.** *Equisetum* belongs to Sphenopsida.

*Adiantum* belongs to Pteropsida.

114. Which of the following is the **correct** match?

- (1) Gymnosperms : *Cedrus, Pinus, Sequoia*
- (2) Angiosperms : *Wolffia, Eucalyptus, Sequoia*
- (3) Bryophytes : *Polytrichum, Polysiphonia, Sphagnum*
- (4) Pteridophytes : *Equisetum, Ginkgo, Adiantum*

**Answer (1)**

**Sol.** Option (1) is correct as *Cedrus, Pinus* and *Sequoia* belongs to gymnosperms.

Option (2) is incorrect as *Sequoia* belongs to gymnosperms, not angiosperms.

Option (3) is incorrect as *Polysiphonia* belongs to rhodophyceae (algae) not bryophytes.

Option (4) is incorrect as *Ginkgo* belongs to gymnosperms, not pteridophytes.

115. Given below are two statements regarding RNA polymerase in prokaryotes.

**Statement I** : In prokaryotes, RNA polymerase is capable of catalysing the process of elongation during transcription.

**Statement II** : RNA polymerase associate transiently with 'Rho' factor to initiate transcription.

In the light of the above statements, choose the **correct** answer from the options given below :

- (1) **Statement I** is true but **Statement II** is false
- (2) **Statement I** is false but **Statement II** is true
- (3) Both **Statement I** and **Statement II** are true
- (4) Both **Statement I** and **Statement II** are false

**Answer (1)**

**Sol.** The RNA polymerase is only capable of catalysing the process of elongation, thus, statement I is correct.

RNA polymerase associates transiently with initiation-factor ( $\sigma$ ) and termination-factor ( $\rho$ ) to initiate and terminate the transcription. Thus, statement II is incorrect.

116. Which of the following is a nucleotide?

- (1) Uridine
- (2) Adenylic acid
- (3) Guanine
- (4) Guanosine

**Answer (2)**



**Sol.** Uridine is a nucleoside. Thus, option (1) is incorrect.

Adenylic acid is a nucleotide. Thus, option (2) is correct.

Guanine is a nitrogenous base. Thus, option (3) is incorrect.

Guanosine is a nucleoside. Thus, option (4) is incorrect.

117. Match **List-I** with **List-II** :

<b>List-I</b>	<b>List-II</b>
A. Vexillary aestivation	I. Brinjal
B. Epipetalous stamens	II. Peach
C. Epiphylous stamens	III. Pea
D. Perigynous flower	IV. Lily

Choose the **correct** answer from the options given below :

- (1) A-III, B-I, C-IV, D-II
- (2) A-III, B-IV, C-I, D-II
- (3) A-III, B-II, C-I, D-IV
- (4) A-II, B-I, C-IV, D-III

**Answer (1)**

**Sol.** In pea, vexillary aestivation is found.

Perigynous flowers are observed in peach.

Epiphylous stamens are found in lily.

Epipetalous stamens are found in brinjal.

118. Match **List-I** with **List-II** :

<b>List-I</b>	<b>List-II</b>
A. China rose	I. Free central
B. Mustard	II. Basal
C. Primrose	III. Axile
D. Marigold	IV. Parietal

Choose the **correct** answer from the options given below :

- (1) A-IV, B-III, C-II, D-I
- (2) A-II, B-III, C-IV, D-I
- (3) A-III, B-IV, C-I, D-II
- (4) A-III, B-IV, C-II, D-I

**Answer (3)**

**Sol.** China rose exhibits axile placentation.

Mustard exhibits parietal placentation.

Primrose exhibits free central placentation.

Marigold exhibits basal placentation.

119. Which of the following helps in maintenance of the pressure gradient in sieve tubes?

- (1) Albuminous cells
- (2) Sieve cells
- (3) Phloem parenchyma
- (4) Companion cells

**Answer (4)**

**Sol.** The companion cells help in maintaining the pressure gradient in the sieve tubes.

120. Mesosome in a cell is a :

- (1) Membrane bound vesicular structure
- (2) Chain of many ribosomes attached to a single mRNA
- (3) Special structure formed by extension of plasma membrane
- (4) Medium sized chromosome

**Answer (3)**

**Sol.** Mesosomes are formed by the extensions of plasma membrane into the cell. Thus, option (3) is correct.

Lysosomes are membrane bound vesicular structures. Thus, option (1) is incorrect.

Several ribosomes may attach to a single mRNA and form a chain called polyribosomes. Thus, option (2) is incorrect.

121. Match **List-I** with **List-II** :

**List-I**

- A. Abscisic acid
- B. Ethylene
- C. Gibberellin
- D. Cytokinin

**List-II**

- I. Promotes female flowers in cucumber
- II. Helps seeds to withstand desiccation
- III. Helps in nutrient mobilisation
- IV. Promotes bolting in beet, cabbage etc

Choose the **correct** answer from the options given below:

- (1) A-II, B-III, C-IV, D-I
- (2) A-III, B-II, C-I, D-IV
- (3) A-II, B-I, C-IV, D-III
- (4) A-II, B-I, C-III, D-IV

**Answer (3)**

**Sol.** Abscisic acid → Helps seeds to withstand desiccation

Ethylene → Promotes female flowers in cucumber

Gibberellin → Promotes bolting in beet, cabbage etc.

Cytokinin → Helps in nutrient mobilisation

Hence, the correct answer is option (3)

122. Match **List-I** with **List-II** :

<b>List-I</b>	<b>List-II</b>
A. Genetically engineered Human Insulin	I. Gene therapy
B. GM Cotton	II. <i>E. coli</i>
C. ADA Deficiency	III. Antigen-antibody interaction
D. ELISA	IV. <i>Bacillus thuringiensis</i>

Choose the **correct** answer from the options given below:

- (1) A-III, B-II, C-IV, D-I
- (2) A-II, B-I, C-IV, D-III
- (3) A-IV, B-III, C-I, D-II
- (4) A-II, B-IV, C-I, D-III

**Answer (4)**

**Sol.** In genetically engineered human insulin, *E. coli* is used as host cell.

⇒ For creating GM cotton, bacteria *Bacillus thuringiensis* is used.

⇒ Gene therapy is one of the treatment for ADA deficiency.

⇒ ELISA test is based on antigen-antibody interaction.

123. Match **List-I** with **List-II**:

<b>List-I</b>	<b>List-II</b>
A. ETS Complex I	I. NADH Dehydrogenase
B. ETS Complex II	II. Cytochrome $bC_1$
C. ETS Complex III	III. Cytochrome C oxidase
D. ETS Complex IV	IV. Succinate Dehydrogenase

Choose the **correct** answer from the options given below :

- (1) A-IV, B-I, C-III, D-II
- (2) A-I, B-IV, C-II, D-III
- (3) A-III, B-I, C-IV, D-II
- (4) A-I, B-II, C-IV, D-III

**Answer (2)**

**Sol.** ETS complex I → NADH dehydrogenase

ETS complex II → Succinate dehydrogenase

ETS complex III → Cytochrome  $bC_1$  complex

ETS complex IV → Cytochrome C oxidase complex

Hence the correct answer is option (2)

124. Cryopreservation technique is used for :
- (1) Protection of environment
  - (2) Protection of Biodiversity hotspots
  - (3) Preservation of gametes in viable and fertile condition for a long period
  - (4) *In-situ* conservation

**Answer (3)**

**Sol.** Cryopreservation technique is a type of *ex-situ* conservation in which gametes of threatened species can be preserved in viable and fertile conditions for long period.

Hence the correct answer is option (3).

125. Which of the following are **correct** about cellular respiration?
- A. Cellular respiration is the breaking of C-C bonds of complex organic molecules by oxidation.
  - B. The entire cellular respiration takes place in Mitochondria.
  - C. Fermentation takes place under anaerobic condition in germinating seeds.
  - D. The fate of pyruvate formed during glycolysis depends on the type of organism also.
  - E. Water is formed during respiration as a result of  $O_2$  accepting electrons and getting reduced.

Choose the **correct** answer from the options given below:

- (1) A, C, D, E only
- (2) A, B, E only
- (3) A, B, C, E only
- (4) B, C, D, E only

**Answer (1)**

**Sol.** The entire cellular respiration do not take place in mitochondria. The process of glycolysis during respiration occur in cytoplasm of cell.

Hence statement A, C, D and E are correct.

126. Given below are two statements:

**Statement I:** In eukaryotes there are three RNA polymerases in the nucleus in addition to the RNA polymerase found in the organelles.

**Statement II:** All the three RNA polymerases in eukaryotic nucleus have different roles.

In the light of the above statements, choose the **correct** answer from the options given below:

- (1) **Statement I** is correct but **Statement II** is incorrect
- (2) **Statement I** is incorrect but **Statement II** is correct
- (3) Both **Statement I** and **Statement II** are correct
- (4) Both **Statement I** and **Statement II** are incorrect

**Answer (3)**

**Sol.** In eukaryotes, there are at least three RNA polymerase in the nucleus (in addition to the RNA polymerase found in the organelles). There is clear cut division of labour. RNA polymerase I transcribes rRNAs (28S, 18S, and 5.8S), whereas the RNA polymerase III is responsible for transcription of tRNA, 5 SrRNA and SnRNAs. The RNA polymerase II transcribes precursor of mRNA.

Hence statement I and statement II, both are correct.

127. Match List-I with List-II:

	List-I		List-II
A.	Histones	I.	Loosely packed chromatin
B.	Nucleosome	II.	Densely packed Chromatin
C.	Euchromatin	III.	Positively charged basic proteins
D.	Heterochromatin	IV.	DNA wrapped around histone octamer

Choose the **correct** answer from the options given below:

- (1) A-IV, B-III, C-II, D-I
- (2) A-III, B-I, C-IV, D-II
- (3) A-II, B-III, C-IV, D-I
- (4) A-III, B-IV, C-I, D-II

**Answer (4)**

<b>Sol.</b>	Histones	→	Positively charged basic proteins
	Nucleosome	→	DNA wrapped around histone octamer
	Euchromatin	→	Loosely packed chromatin
	Heterochromatin	→	Densely packed chromatin

Hence the correct answer is option (4).

128. Given below are two statements:

**Statement I:** Failure of segregation of chromatids during cell cycle resulting in the gain or loss of whole set of chromosome in an organism is known as aneuploidy.

**Statement II:** Failure of cytokinesis after anaphase stage of cell division results in the gain or loss of a chromosome is called polyploidy.

In the light of the above statements, choose the **correct** answer from the options given below:

- (1) **Statement I** is true but **Statement II** is false
- (2) **Statement I** is false but **Statement II** is true
- (3) Both **Statement I** and **Statement II** are true
- (4) Both **Statement I** and **Statement II** are false

**Answer (4)**

**Sol.** Failure of segregation of chromatids during cell division cycle results in the gain or loss of a chromosome(s), called aneuploidy.

Failure of cytokinesis after telophase of cell division results in an increase in a whole set of chromosomes in an organism and this phenomenon is known as polyploidy.

Hence the correct answer is option (4).

129. Recombination between homologous chromosomes is completed by the end of

- (1) Diakinesis
- (2) Zygotene
- (3) Diplotene
- (4) Pachytene

**Answer (4)**

**Sol.** Recombination between homologous chromosomes is completed by the end of pachytene.

130. Match **List-I** with **List-II**:

	List-I		List-II
A.	Metacentric chromosome	I.	Chromosome has a terminal centromere
B.	Sub-metacentric chromosome	II.	Middle centromere forming two equal arms of chromosome
C.	Acrocentric chromosome	III.	Centromere is slightly away from the middle of chromosome resulting into two unequal arms
D.	Telocentric chromosome	IV.	Centromere is situated close to its end forming one extremely short and one very long arm

Choose the **correct** answer from the options given below:

- (1) A-II, B-I, C-IV, D-III
- (2) A-IV, B-I, C-II, D-III
- (3) A-I, B-II, C-III, D-IV
- (4) A-II, B-III, C-IV, D-I

**Answer (4)**

**Sol.**

Metacentric chromosomes	→	Middle centromere forming two equal arms of chromosomes
Sub-metacentric chromosomes	→	Centromere is slightly away from the middle of chromosomes resulting into two unequal arms.
Acrocentric chromosomes	→	Centromere is situated close to its end forming one extremely short and one very long arm.
Telocentric chromosomes	→	Chromosome has a terminal centromere

Hence the correct answer is option (4).

131. Ligases is a class of enzymes responsible for catalysing the linking together of two compounds.

Which of the following bonds is not catalysed by it?

- (1) C – C
- (2) P – O
- (3) C – O
- (4) C – N

**Answer (1)**

**Sol.** Option (1) is the correct answer because, ligases are the enzymes that catalyse the linking together of 2 compounds, e.g., enzymes which catalyse joining of C – O, C – S, C – N, P – O etc. bonds.

⇒ Options (2), (3) and (4) are wrong as ligase catalyse the joining of P – O, C – O & C – N bonds.

132. F. Skoog observed that callus proliferated from the internodal segments of tobacco stem when auxin was supplied with one of the following except :

- (1) Extract of Vascular tissues
- (2) Coconut milk
- (3) Absciscic acid
- (4) Yeast Extract

**Answer (3)**

**Sol.** F. Skoog observed that from the internodal segments of tobacco stems the callus proliferated only if in addition to auxins the nutrient medium was supplied with the extracts of vascular tissues, yeast extract, coconut milk or DNA. Miller et al. later identified and crystallised the cytokinesis promoting active substance that they termed kinetin.

133. Given below are some statements about plant growth regulators.

- A. All GAs are acidic in nature.
- B. Auxins are antagonists to GAs.
- C. Zeatin was isolated from coconut milk.
- D. Ethylene induces flowering in Mango.
- E. Absciscic acid induces parthenocarpy.

Choose the correct set of statements from the options given below:

- (1) A, C, D
- (2) B, E
- (3) A, B, C
- (4) B, D, E

**Answer (1)**

**Sol.** Absciscic acid is antagonistic to Gibberellic acid.

Auxins induce parthenocarpy in certain fruits, such as, tomatoes.

134. Identify the **incorrect** statement related to gel electrophoresis.
- (1) Separated DNA fragments can be directly seen under UV radiation
  - (2) Separated DNA can be extracted from gel piece
  - (3) Fragment of DNA moves toward anode
  - (4) Sieving effect of agarose gel helps in separation of DNA fragments

**Answer (1)**

**Sol.** Option (1) is the correct answer because separated DNA fragments can be visualised only after staining the DNA with a compound known as ethidium bromide followed by exposure to UV radiation. We cannot see pure DNA fragments in visible light and without staining.

- ⇒ The DNA fragments separate (resolve) according to their size through sieving effect provided by agarose gel.
- ⇒ DNA is a negatively charged molecule, hence it moves towards the positive electrode (anode).

135. Which of the following examples show monocarpellary, unilocular ovary with many ovules?

- A. *Sesbania*
- B. Brinjal
- C. *Indigofera*
- D. Tobacco
- E. *Asparagus*

Choose the correct answer from the options given below :

- (1) B and E only
- (2) C, D and E only
- (3) A, B and D only
- (4) A and C only

**Answer (4)**

**Sol.** Monocarpellary, unilocular ovary with many ovules is the characteristic feature of the members of the family Fabaceae. *Sesbania* and *Indigofera* are the members of this family. Brinjal and tobacco belong to the family Solanaceae whereas *Asparagus* belongs to the family Liliaceae.

**SECTION-B**

136. Given below are two statements :

**Statement I:** In the *lac* operon, the *z* gene codes for beta-galactosidase which is primarily responsible for the hydrolysis of lactose into galactose and glucose.

**Statement II:** In addition to lactose, glucose or galactose can also induce *lac* operon.

In the light of the above statements, choose the **correct** answer from the options given below :

- (1) **Statement I** is true but **Statement II** is false
- (2) **Statement I** is false but **Statement II** is true
- (3) Both **Statement I** and **Statement II** are true
- (4) Both **Statement I** and **Statement II** are false

**Answer (1)**

**Sol.** In the *lac* operon the *z*- gene codes for  $\beta$ -galactosidase which is primarily responsible for the hydrolysis of lactose into its monomeric units, galactose and glucose.

Glucose and galactose cannot act as the inducers of *lac* operon. Rather, lactose or allolactose act as inducers of *lac* operon.



137. The part marked as 'x' in the given figure is

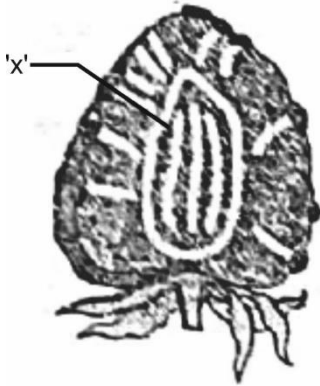

- (1) Endosperm
- (2) Thalamus
- (3) Endocarp
- (4) Mesocarp

**Answer (2)**

**Sol.** The given figure is of the false fruit, strawberry and 'x' represents the thalamus.

138. Given below are two statements:

**Statement I:** In a dicotyledonous leaf, the adaxial epidermis generally bears more stomata than the abaxial epidermis.

**Statement II:** In a dicotyledonous leaf, the adaxially placed palisade parenchyma is made up of elongated cells, which are arranged vertically and parallel to each other.

In the light of the above statements, choose the **correct** answer from the options given below:

- (1) **Statement I** is true but **Statement II** is false
- (2) **Statement I** is false but **Statement II** is true
- (3) Both **Statement I** and **Statement II** are true
- (4) Both **Statement I** and **Statement II** are false

**Answer (2)**

**Sol.** In a dicotyledonous leaf, adaxial epidermis (upper surface) generally bears very less stomata and may even lack stomata. It has less number of stomata in comparison to abaxial surface.

The adaxially placed palisade parenchyma is made up of elongated cells, arranged vertically and parallel to each other.

139. Which of the following are **not** fatty acids?

- A. Glutamic acid
- B. Arachidonic acid
- C. Palmitic acid
- D. Lecithin
- E. Aspartic acid

Choose the **correct** answer from the options given below :

- (1) C, D and E only
- (2) A and B only
- (3) A, D and E only
- (4) B and C only

**Answer (3)**

**Sol.** Option (3) is the correct answer because glutamic acid and aspartic acid are amino acids while lecithin is a phospholipid. Palmitic acid and arachidonic acid are fatty acids.

140. Consider the pyramid of energy of an ecosystem given below:

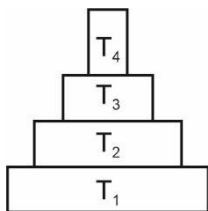

If  $T_4$  is equivalent to 1000 J, what is the value at  $T_1$ ?

- (1)  $\frac{10000}{10}$  J
- (2)  $\frac{10000}{10} \times 4$  J
- (3) 10,000 J
- (4) 10,00,000 J

**Answer (4)**

**Sol.** According to the given pyramid of energy, if  $T_4$  is equivalent to 1000 J, then according to the 10 percent law, which states that only 10 percent of energy is transferred to each trophic level from the lower trophic level, the value at  $T_1$  is 10,00,000 J.

$$T_1 = 10,00,000 \text{ J}$$

$$T_2 = \frac{10}{100} \times 10,00,000 = 1,00,000 \text{ J}$$

$$T_3 = \frac{10}{100} \times 100000 = 10,000 \text{ J}$$

$$T_4 = \frac{10}{100} \times 10000 = 1000 \text{ J}$$

141. Which one of the following products diffuses out of the chloroplast during photosynthesis?

- (1) ADP
- (2) NADPH
- (3) O<sub>2</sub>
- (4) ATP

**Answer (3)**

**Sol.** Product of light reaction are ATP, NADPH and O<sub>2</sub>. Of these O<sub>2</sub> diffuses out of the chloroplast while ATP and NADPH are used to drive the processes leading to synthesis of food, more accurately, sugars.

142. Recombinant DNA molecule can be created normally by cutting the vector DNA and source DNA respectively with:

- (1) Hind II, Hind II
- (2) Hind II, Alu I
- (3) Hind II, EcoR I
- (4) Hind II, BamHI

**Answer (1)**

**Sol.** Option (1) is the correct answer because, unless we cut the vector and the source DNA with the same restriction enzyme, the recombinant vector molecule cannot be created.

In options (2), (3) and (4), restriction enzymes are different for cutting the vector DNA and source DNA, so they cannot be the answers.

143. Which one of the following is not a limitation of ecological pyramids?

- (1) Saprophytes are not given any place in ecological pyramids
- (2) It assumes a simple food chain, that almost never exists in nature
- (3) It accommodates a food web
- (4) It does not take into account the same species belonging to two or more trophic levels

**Answer (3)**

**Sol.** There are certain limitation of ecological pyramids.

Such as :

- It does not take into account the same species belonging to two or more trophic levels.
- It assumes a simple food chain, something that almost never exists in nature.
- It does not accommodate a food web.
- Saprophytes are not given any place in ecological pyramids even though they play a vital role in the ecosystem.

144. The *Bt* toxin in genetically engineered *Bt* cotton kills the pest by:

- (1) Creating pores in the midgut
- (2) Damaging the respiratory system
- (3) Degenerating the nervous system
- (4) Altering the pH of body fluids

**Answer (1)**

**Sol.** Option (1) is the correct answer because the activated toxin binds to the surface of midgut epithelial cells and creates pore that cause cell swelling and lysis and eventually cause death of the insect.

*Bt* toxin doesn't kill pest by affecting their respiratory system, nervous system and it doesn't alter the pH of body fluids. So, options (2), (3) and (4) are not the answer.

145. Match List-I with List-II:

List-I	List-II
Organisms	Mode of Nutrition
A. Euglenoid	I. Parasitic
B. Dinoflagellate	II. Saprophytic
C. Slime mould	III. Photosynthetic
D. <i>Plasmodium</i>	IV. Switching between photosynthetic and heterotrophic mode

Choose the **correct** answer from the options given below:

- (1) A-III, B-IV, C-II, D-I
- (2) A-IV, B-II, C-I, D-III
- (3) A-IV, B-III, C-II, D-I
- (4) A-IV, B-II, C-III, D-I

**Answer (3)**

**Sol.** Euglenoids are photosynthetic in the presence of sunlight, when deprived of sunlight they behave like heterotrophs.

Dinoflagellates are mostly marine and photosynthetic.

Slime moulds are saprophytic protists.

*Plasmodium* is malarial parasite which cause malaria.

146. Which of the following graphs depicts the effect of substrate concentration on velocity of enzyme catalysed reaction?

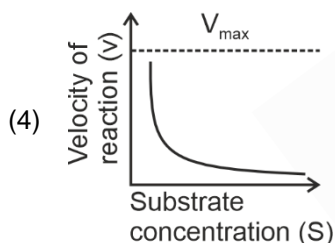
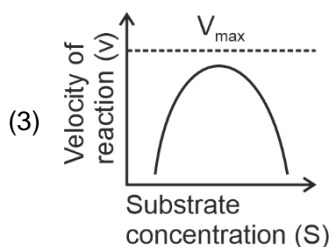
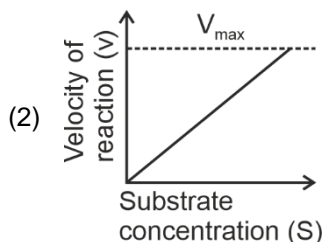
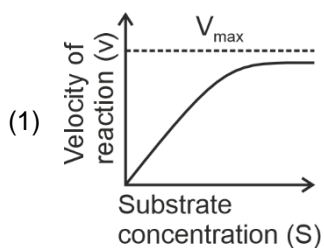

**Answer (1)**

**Sol.** Option (1) is the correct answer because with the increase in substrate concentration, the velocity of enzymatic reaction rises at first. The reaction ultimately reaches maximum velocity ( $V_{max}$ ) which is not exceeded by any further rise in concentration of the substrate. This is because the enzyme molecules are fewer than substrate molecules and after saturation of these molecules, there are no free enzyme molecules to bind the additional substrate molecules

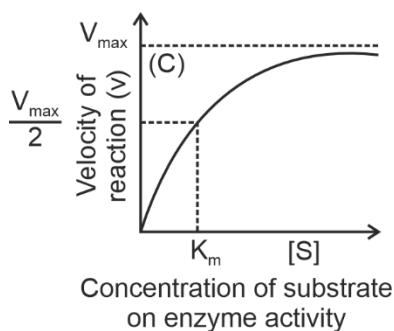

Option (2) is incorrect as velocity of reaction is continuously increasing in the given graph.

In option (3) after reaching at  $V_{max}$ , velocity declines while in option (4) velocity of reaction declines from high on increasing substrate concentration. So, option (3) and (4) are incorrect.

147. When will the population density increase, under special conditions?

When the number of :

- (1) Deaths exceeds number of births and also number of emigrants equals number of immigrants.
- (2) Births plus number of immigrants equals number of deaths plus number of emigrants.
- (3) Births plus number of emigrants is more than the number of deaths plus number of immigrants.
- (4) Births plus number of immigrants is more than the sum of number of deaths and number of emigrants.

**Answer (4)**

**Sol.** (N) is the population density at time t, then its density at time t + 1 is

$$N_{t+1} = N_t + [(B + I) - (D + E)]$$

Population density will increase if the number of births plus the number of immigrants (B + I) is more than the number of deaths plus the number of emigrants (D + E).

148. When a tall pea plant with round seeds was selfed, it produced the progeny of :

- (a) Tall plants with round seeds and
- (b) Tall plants with wrinkled seeds.

Identify the genotype of the parent plant.

- (1) TtRr
- (2) TtRR
- (3) TTRR
- (4) TTRr

**Answer (4)**

**Sol.** As per the type of given progeny the genotype of the parent will be TTRr.

$$\text{Selfing} = \begin{matrix} \text{♀} \\ \text{TTRr} \end{matrix} \times \begin{matrix} \text{♂} \\ \text{TTRr} \end{matrix}$$

	$\frac{\text{♂}}{\text{♀}}$	TR	Tr
F <sub>1</sub> generation	TR	TTRR	TTRr
	Tr	TTRr	TTrr

According to the above cross progeny will be Tall round and Tall wrinkle.

149. Match **List-I** with **List-II**:

	List-I		List-II
A.	Biodiversity hotspot	I.	Khasi and Jantia hills in Meghalaya
B.	Sacred groves	II.	World Summit on Sustainable Development 2002
C.	Johannesburg, South Africa	III.	<i>Parthenium</i>
D.	Alien species invasion	IV.	Western Ghats

Choose the **correct** answer from the options given below:

- (1) A-IV, B-I, C-II, D-III
- (2) A-II, B-III, C-IV, D-I
- (3) A-I, B-IV, C-III, D-II
- (4) A-III, B-I, C-II, D-IV

**Answer (1)**

**Sol.** (1) Biodiversity hotspots are regions with very high levels of species richness and high degree of endemism.

Eg. Western Ghats, Sri Lanka, Indo-Burma and Himalaya

(2) In many cultures, tracts of forest were set aside, and all the trees and wildlife within were venerated and given total protection. Such sacred groves are found in Khasi and Jaintia, Hills in Meghalaya

(3) The world summit on sustainable development held in 2002 in Johannesburg, South Africa.

(4) *Parthenium* is an alien species

150. Observe the given figure. Identify the different stages labelled with alphabets by selecting the **correct** option.

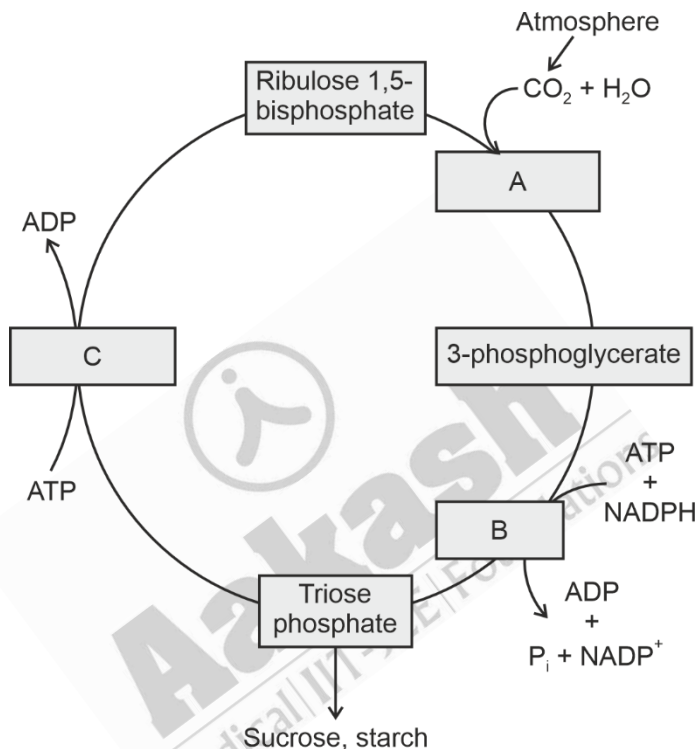

- (1) A-Carboxylation, B-Regeneration, C-Reduction
- (2) A-Reduction, B-Decarboxylation, C-Regeneration
- (3) A-Carboxylation, B-Reduction, C-Regeneration
- (4) A-Reduction, B-Carboxylation, C-Regeneration

**Answer (3)**

**Sol.** The calvin cycle proceeds in three stages:

(A) Carboxylation, during which  $\text{CO}_2$  combines with ribulose-1,5-bisphosphate.

(B) Reduction, during which carbohydrate is formed at the expense of the photochemically made ATP and NADPH.

(C) Regeneration during which the  $\text{CO}_2$  acceptor ribulose-1,5-bisphosphate is formed again so that the cycle continues.





**Sol.** Option (1) is the correct answer because

	<b>List I</b> <b>Location of Joint</b>		<b>List II</b> <b>Type of Joint</b>
A.	Joint between humerus and pectoral girdle	II.	Ball and Socket joint
B.	Knee joint	III.	Hinge joint
C.	Joint between atlas and axis	IV.	Pivot joint
D.	Joint between carpals	I.	Gliding joint

Thus, A-II, B-III, C-IV, D-I is the correct match.

153. Following are the steps involved in action of toxin in Bt. Cotton

- The inactive toxin converted into active form due to alkaline pH of gut of insect.
- Bacillus thuringiensis* produce crystals with toxic insecticidal proteins.
- The alkaline pH solubilises the crystals.
- The activated toxin binds to the surface of midgut cells, creates pores and causes death of the insect.
- The toxin proteins exist as inactive protoxins in bacteria.

Choose the correct sequence of steps from the options given below:

- $E \rightarrow C \rightarrow B \rightarrow A \rightarrow D$
- $B \rightarrow C \rightarrow A \rightarrow E \rightarrow D$
- $A \rightarrow E \rightarrow B \rightarrow D \rightarrow C$
- $B \rightarrow E \rightarrow C \rightarrow A \rightarrow D$

**Answer (4)**

**Sol.** Option (4) is the correct answer because the correct sequence of action of toxin in Bt. cotton is

- Bacillus thuringiensis* produces crystals with toxic insecticidal proteins.
- The toxin proteins exist as inactive protoxins in bacteria.
- The alkaline pH solubilises the crystals.
- The inactive toxin converted into active form due to alkaline pH of gut of insect.
- The activated toxin binds to the surface of midgut cells, creates pores and causes death of the insect.

Hence,  $B \rightarrow E \rightarrow C \rightarrow A \rightarrow D$  is the correct order.

154. Match List-I with List-II:

	<b>List I</b>		<b>List II</b>
A.	Gene pool	I.	Stable within a generation
B.	Genetic drift	II.	Change in gene frequency by chance
C.	Gene flow	III.	Transfer of genes into or out of population
D.	Gene frequency	IV.	Total number of genes and their alleles

Choose the correct answer from the options given below:

- A-III, B-II, C-I, D-IV
- A-IV, B-II, C-III, D-I
- A-I, B-II, C-III, D-IV
- A-II, B-III, C-IV, D-I

**Answer (2)**

**Sol.** The correct answer is option (2), because

	List I		List II
A.	Gene pool	IV.	Total number of genes and their alleles
B.	Genetic drift	II.	When change in gene frequency occurs by chance
C.	Gene flow	III.	When gene migration/transfer of genes into or out of population occurs multiple times.
D.	Gene frequency	I.	According to Hardy Weinberg principle, gene frequency remains stable within generations.

Hence [A-IV, B-II, C-III, D-I] is the correct match.

155. Which evolutionary phenomenon is depicted by the sketch given in figure?

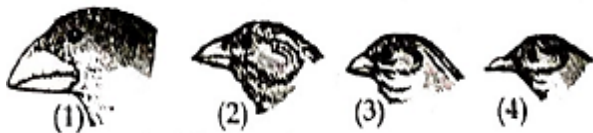

- (1) Artificial selection
- (2) Genetic drift
- (3) Convergent evolution
- (4) Adaptive radiation

**Answer (4)**

**Sol.** The correct answer is option (4), because the evolutionary phenomenon depicted in the sketch is adaptive radiation as from the original seed-eating features, many other forms of finches with altered beaks arose, enabling them to become insectivorous and vegetarian finches.

Option (1) is incorrect because artificial selection is anthropogenic, where man breeds selected plants and animals for different uses.

Option (2) is incorrect because genetic drift is change in gene frequency by chance.

Option (3) is incorrect because convergent evolution is when different structures, with different origins evolve for the same function due to same habitat and hence have similarity. Darwin's finches are the example of divergent evolution.

156. A person with blood group  $ARh^-$  can receive the blood transfusion from which of the following types?

- A.  $BRh^-$
- B.  $ABRh^-$
- C.  $ORh^-$
- D.  $ARh^-$
- E.  $ARh^+$

Choose the correct answer from the options given below :

- (1) D and E only
- (2) D only
- (3) A and B only
- (4) C and D only

**Answer (4)**

**Sol.** The correct answer is option (4) because recipient is A blood group with Rh(-ve) antigen, hence cannot receive blood from any blood group with Rh(+ve) antigen and as A blood group individuals have anti-B antibodies in plasma. So, donor could be O (Rh -ve) and A (Rh -ve) only.

Options (1), (2) and (3) are not correct answers because B<sup>-</sup>, AB<sup>-</sup> and A<sup>+</sup> blood groups will lead to serve clumping reaction.

157. Enzymes that catalyse the removal of groups from substrates by mechanisms other than hydrolysis leaving double bonds, are known as :

- (1) Transferases
- (2) Oxidoreductases
- (3) Dehydrogenases
- (4) Lyases

**Answer (4)**

**Sol.** The correct answer is option (4) because lyases are group of enzymes that catalyse the removal of groups from substrates by mechanisms other than hydrolysis leaving double bonds.

Option (1) is incorrect because transferases are enzymes catalysing a transfer of a group G (other than hydrogen) between a pair of substrate S and S'.

Option (2) is incorrect because oxidoreductases are enzymes which catalyse oxidation-reduction between two substrates S and S'.

Option (3) is incorrect because dehydrogenases are also known as oxidoreductases.

158. Match **List-I** with **List-II**.

	<b>List-I Event</b>		<b>List-II Stage of Prophase-I (Meiosis-I)</b>
A.	Chiasmata formation	I.	Pachytene
B.	Crossing over	II.	Diakinesis
C.	Synaptonemal complex formation	III.	Diplojene
D.	Terminalisation of chiasmata	IV.	Zygotene

Choose the correct answer from the options given below :

- (1) A-III, B-I, C-IV, D-II
- (2) A-II, B-I, C-III, D-IV
- (3) A-III, B-I, C-II, D-IV
- (4) A-II, B-III, C-IV, D-I

**Answer (1)**

**Sol.** Zygotene is the second stage of prophase I during this stage synaptonemal complex formation occur.

In pachytene the four chromatids of each bivalent chromosomes becomes distinct and clearly appears as tetrad and in this stage crossing over occurs.

Diplojene is recognised by the dissolution of the synaptonemal complex and the tendency of the recombined homologous chromosomes of the bivalents to separate from each other except at the sites of crossovers. These X-shaped are called chiasmata. Diakinesis is marked by terminalisation of chiasmata.



161. Which of the following statements is **correct** about the type of junction and their role in our body?
- (1) Adhering junctions facilitate the cells to communicate with each other.
  - (2) Tight junctions help to stop substances from leaking across a tissue.
  - (3) Tight junctions help to perform cementing to keep neighbouring cells together.
  - (4) Gap junctions help to create gap between the cells and tissues.

**Answer (2)**

**Sol.** The correct answer is option (2), because tight junctions help to stop substances from leaking across a tissue.

Options (1), (3) and (4) are incorrect because

- Adhering junctions perform cementing to keep neighbouring cells together.
- Gap junctions facilitate the cells to communicate with each other by connecting the cytoplasm of adjoining cells for rapid transfer of ions, small molecules and sometimes big molecules.

162. Select the restriction endonuclease enzymes whose restriction sites are present for the tetracycline resistance ( $tet^R$ ) gene in the pBR322 cloning vector.

- (1) Bam HI and Sal I
- (2) Sal I and Pst I
- (3) Pst I and Pvu I
- (4) Pvu I and Bam HI

**Answer (1)**

**Sol.** The correct answer is option (1), because the restriction sites for restriction endonucleases Bam HI and Sal I are present within the  $tet^R$  gene in the pBR322 cloning vector.

Options (2), (3) and (4) are incorrect because the restriction sites of *Pst* I and *Pvu* I are present within the  $amp^R$  gene in the pBR322 cloning vector.

163. Match List-I with List-II.

	List-I		List-II
A.	Chondrichthyes	I.	<i>Clarias</i>
B.	Cyclostomata	II.	<i>Carcharodon</i>
C.	Osteichthyes	III.	<i>Myxine</i>
D.	Amphibia	IV.	<i>Ichthyophis</i>

Choose the **correct** answer from the options given below:

- (1) A-II, B-IV, C-I, D-III
- (2) A-I, B-III, C-II, D-IV
- (3) A-II, B-III, C-I, D-IV
- (4) A-I, B-II, C-III, D-IV

**Answer (3)**

**Sol.** The correct answer is option (3), because

- *Carcharodon* is a cartilaginous fish which belongs to the class Chondrichthyes.
- *Myxine* is a jawless vertebrate that belongs to the class Cyclostomata.
- *Clarias* is a bony fish which belongs to the class Osteichthyes.
- *Ichthyophis* is a limbless animal which belongs to the class Amphibia.

Hence the correct matches are

A. Chondrichthyes – *Carcharodon*

- B. Cyclostomata – *Myxine*
- C. Osteichthyes – *Clarias*
- D. Amphibia – *Ichthyophis*

164. Given below are two statements: One is labelled as **Assertion A** and the other is labelled as **Reason R**.

**Assertion A:** During menstrual cycle, the ovulation takes place approximately on 14<sup>th</sup> day.

**Reason R:** Rapid secretion of LH in the middle of menstrual cycle induces rupture of Graafian follicle and thereby the release of ovum.

In the light of the above statements, choose the most appropriate answer from the options given below.

- (1) **A** is correct but **R** is not correct.
- (2) **A** is not correct but **R** is correct.
- (3) Both **A** and **R** are correct and **R** is the correct explanation of **A**.
- (4) Both **A** and **R** are correct but **R** is NOT the correct explanation of **A**.

**Answer (3)**

**Sol.** The correct answer is option (3), because in a 28 days menstrual cycle of a human female, rapid secretion of LH leading to its maximum level during the mid-cycle (14<sup>th</sup> day) called LH surge induces the rupture of Graafian follicle and thereby the release of ovum (ovulation).

Hence, both (A) and (R) are correct and (R) is the correct explanation of (A).

165. Match List-I with List-II with respect to convergent evolution:

	List-I		List-II
A.	Lemur	I.	Flying phalanger
B.	Bobcat	II.	Numbat
C.	Anteater	III.	Spotted cuscus
D.	Flying squirrels	IV.	Tasmanian tiger cat

Choose the **correct** answer from the options given below:

- (1) A-III, B-IV, C-II, D-I
- (2) A-III, B-II, C-IV, D-I
- (3) A-IV, B-III, C-II, D-I
- (4) A-IV, B-II, C-III, D-I

**Answer (1)**

**Sol.** The correct answer is option (1), because

- Lemur is a placental mammal, shows convergent evolution with spotted cuscus which is an Australian marsupial.
- Bobcat is a placental mammal, shows convergent evolution with Tasmanian tiger cat which is an Australian marsupial.
- Anteater is a placental mammal, shows convergent evolution with Numbat which is an Australian marsupial.
- Flying squirrel is a placental mammal, shows convergent evolution flying Phalanger which is Australian marsupial.









170. Match **List-I** with **List-II** relating to examples of various kind of IUDs and barrier:

	List-I		List-II
A.	Copper releasing IUD	I.	Vaults
B.	Non-medicated IUD	II.	Multiload 375
C.	Contraceptive barrier	III.	LNG-20
D.	Hormone releasing IUD	IV.	Lippes loop

Choose the **correct** answer from the options given below:

- (1) A-II, B-IV, C-III, D-I
- (2) A-IV, B-III, C-I, D-II
- (3) A-II, B-I, C-III, D-IV
- (4) A-II, B-IV, C-I, D-III

**Answer (4)**

**Sol.** The correct answer is option (4) because

- Multiload 375 is a copper releasing IUD which suppresses sperm motility and fertilizing capacity of sperms.
- Lippes loop is a non-medicated intra uterine device.
- Vaults are barrier type of contraceptives which prevent physical meeting of ovum and sperms.
- LNG-20 is a hormone releasing IUD that makes the uterus unsuitable for implantation and the cervix hostile to the sperms.

Hence the correct matches are

- |                          |   |               |
|--------------------------|---|---------------|
| A. Copper releasing IUD  | - | Multiload 375 |
| B. Non-medicated IUD     | - | Lippes loop   |
| C. Contraceptive barrier | - | Vaults        |
| D. Hormone releasing IUD | - | LNG-20        |

171. Given below are two statements:

**Statement I:** Antibiotics are chemicals produced by microbes that kill other microbes.

**Statement II:** Antibodies are chemicals formed in body that eliminate microbes.

In the light of the above statements, choose the most appropriate answer from the options given below.

- (1) **Statement I** is correct but **Statement II** is incorrect
- (2) **Statement I** is incorrect but **Statement II** is correct
- (3) Both **Statement I** and **Statement II** are correct
- (4) Both **Statement I** and **Statement II** are incorrect

**Answer (3)**

**Sol.** The correct answer is option (3) as both **statement I** and **statement II** are correct.

Antibiotics are chemicals produced by microorganisms.

Antibiotics have the capacity to inhibit the growth and eventually destroy bacterial and other microorganisms in low concentration. Thus, **statement I** is correct.

Antibodies are immunoglobulins produced in the body in response to any attack from pathogens. Antibodies facilitate killing of microbes by various mechanisms and provide immunity to the body. Thus, **statement II** is also correct.

172. Arrange the following parts in human Mammary gland, traversing the route of milk ejection.

- |                     |                     |
|---------------------|---------------------|
| A. Mammary duct     | B. Lactiferous duct |
| C. Mammary alveolus | D. Ampulla          |
| E. Mammary tubule   |                     |

Choose the **correct** answer from the options given below:

- (1) D → C → E → A → B
- (2) C → E → B → A → D
- (3) C → E → A → D → B
- (4) A → C → E → D → B

**Answer (3)**

**Sol.** The correct answer is Option (3) as the correct route of milk ejection *via* mammary glands in human is:

Mammary alveolus → Mammary tubule → Mammary duct → Mammary ampulla → Lactiferous duct

In the question, the given structures are represented as:-

C → E → A → D → B (given in option 3)

The other option *i.e.*, (1), (2) and (4) are incorrect as they represent the wrong pathway.

173. Which of the following are correct about *EcoRI*?

- A. Cut the DNA with blunt end
- B. Cut the DNA with sticky end
- C. Recognise a specific palindromic sequence
- D. Cut the DNA between the base G and A when encounters the DNA sequence 'GAATTC'
- E. Exonuclease

Choose the **correct** answer from the options given below:

- (1) B, C, E only
- (2) A, D, E only
- (3) A, C, D only
- (4) B, C, D only

**Answer (4)**

**Sol.** The correct answer is option (4) as

*EcoRI* does not cut the DNA with blunt ends. Instead, it cuts the DNA with sticky / cohesive / staggered ends on each strand.

*EcoRI* is a restriction endonuclease that recognises a specific palindromic sequence and cuts at a specific site within the DNA, known as the restriction site. It is not an exonuclease as exonucleases remove nucleotides from the free ends of the DNA.

The recognition sequence for *EcoRI* is  $5'-G^{\downarrow}-A-A-T-T-C-3'$   
 $3'-C-T-T-A-A_{\uparrow}-G-5'$  and it cuts the DNA between

bases G and A only when the sequence GAATTC is present in the DNA.

Therefore, 'A' and 'E' represent incorrect features about *EcoRI*, whereas 'B', 'C' and 'D' are correct features of *EcoRI*.

The other options, *i.e.*, (1), (2) and (3) are incorrect as they represent incorrect combinations of features w.r.t. *EcoRI*.



- A. Malignant tumors – Exhibit the property of metastasis  
 B. MALT – Mucosa Associated Lymphoid Tissue  
 C. NACO – National AIDS Control Organisation  
 D.  $\alpha$ -Interferons – Biological response modifiers given to cancer patients that activate their immune system and help in destroying the tumor.

Thus, correct match is, A-III, B-IV, C-II, D-I and therefore the correct answer is option (1).

The other options *i.e.*, (2), (3) and (4) are incorrect as they represent mismatches.

176. Open Circulatory system is present in:

- (1) *Palaemon, Nereis, Balanoglossus*  
 (2) *Hirudinaria, Bombyx, Salpa*  
 (3) *Anopheles, Limax, Limulus*  
 (4) *Pheretima, Musca, Pila*

**Answer (3)**

**Sol.** The correct answer is option (3) as *Anopheles* (Arthropods), *Limax* (Mollusc) and *Limulus* (Arthropods) have an open circulatory system.

Option (1) is incorrect as *Nereis* (Annelid) has a closed circulatory system.

Option (2) is incorrect as *Hirudinaria* (Annelid) has a closed circulatory system.

Option (4) is incorrect as *Pheretima* (Annelid) has a closed circulatory system.

Arthropods (*Palaemon, Bombyx, Musca*) have an open circulatory system.

Hemichordates (*Balanoglossus*) have an open circulatory system.

177. In which of the following connective tissues, the cells secrete fibres of collagen or elastin?

- A. Cartilage                                      B. Bone                                      C. Adipose tissue  
 D. Blood    E. Areolar tissue

Choose the **most appropriate** answer from the options given below :

- (1) B, C, D and E only                                      (2) A, B, C and E only  
 (3) B, C and D only    (4) A, C and D only

**Answer (2)**

**Sol.** The correct answer is option (2) as blood does not contain fibre secreting cells called as fibroblasts.

Whereas, cartilage, bone, adipose tissue and areolar tissue contain cells that secrete fibres of collagen on elastin or structural protein.

The other options (1), (3) and (4) are incorrect as they mention blood which lacks fibroblasts.

178. Which of the following pairs is an **incorrect** match?

- (1) Annelids and arthropods-Bilateral symmetry  
 (2) Sponges-Acoelomates  
 (3) Coelenterates and Ctenophores-Radial symmetry  
 (4) Platyhelminthes-Diploblastic organisation

**Answer (4)**

**Sol.** The correct answer is option (4) as it represents an incorrect match because platyhelminthes are triploblastic organisms; not diploblastic.

Option (1) represents the correct match as annelids and arthropods exhibit bilateral symmetry.

Option (2) represents the correct match as sponges are acoelomates.

Option (3) represents the correct match as coelenterates and ctenophores exhibit radial symmetry.

Hence, option (1), (2) and (3) cannot be the answer.

179. Match **List-I** with **List-II**:

	<b>List-I</b>		<b>List-II</b>
A.	Residual Volume	I.	Maximum volume of air that can be breathed in after forced expiration
B.	Vital Capacity	II.	Volume of air inspired or expired during normal respiration
C.	Expiratory Capacity	III.	Volume of air remaining in lungs after forcible expiration
D.	Tidal Volume	IV.	Total volume of air expired after normal inspiration

Choose the **correct** answer from the options given below:

(1) A-IV, B-III, C-II, D-I

(2) A-II, B-IV, C-I, D-III

(3) A-III, B-I, C-IV, D-II

(4) A-I, B-II, C-III, D-IV

**Answer (3)**

**Sol.** Option (3) is the answer of this question because correct match is A-III, B-I, C-IV, D-II.

Option (1), (2) and (4) are incorrect because they are not correctly matched.

**Residual volume** – Volume of air remaining in lungs after forcible expiration.

**Vital capacity** – Maximum volume of air that can be breathed in after forced expiration.

**Expiratory Capacity** – Total volume of air expired after normal inspiration.

**Tidal volume** – Volume of air inspired or expired during normal respiration.

180. Match **List-I** with **List-II**:

	<b>List-I</b>		<b>List-II</b>
A.	Living Fossil	I.	Elongated canine teeth
B.	Connecting Link	II.	Vermiform appendix
C.	Vestigial Organ	III.	<i>Echidna</i>
D.	Atavism	IV.	<i>Latimeria</i>

Choose the **correct** answer from the options given below:

(1) A-IV, B-III, C-II, D-I

(2) A-IV, B-II, C-III, D-I

(3) A-IV, B-III, C-I, D-II

(4) A-III, B-IV, C-I, D-II

**Answer (1)**

**Sol.** The correct answer is option (1) because:

- *Latimeria* is a living fossil, it is a bony fish, so (A) matches with (IV).
- *Echidna* is the connecting link between the reptiles and the mammals, so (B) matches with (III).
- Vestigial organs are remnants of organs which were complete and functional in the ancestral forms. The vermiform appendix of man is a vestigial organ. So, (C) matches with (II).
- Atavism is a trait of distant ancestors that reappears in the modern day, e.g., elongated canine teeth in humans. So, (D) matches with (I).

Options (2), (3) and (4) are incorrect as (A), (B), (C) and (D) have incorrect matches in them.

181. Match List-I with List -II

	List-I		List-II
A.	Schwann cells	I.	Neurotransmitter
B.	Synaptic knob	II.	Cerebral cortex
C.	Bipolar neurons	III.	Myelin sheath
D.	Multipolar neurons	IV.	Retina

Choose the **correct** answer from the options given below:

- (1) A-III, B-I, C-IV, D-II
- (2) A-I, B-IV, C-II, D-III
- (3) A-IV, B-III, C-II, D-I
- (4) A-II, B-III, C-I, D-IV

**Answer (1)**

**Sol.** The correct answer is option (1) because

- The myelinated nerve fibres are enveloped with Schwann cells, which form a myelin sheath around the axon. So, (A) matches with (III)
- Synaptic knob possess synaptic vesicles containing chemicals called neurotransmitters. So, (B) matches with (I)
- Bipolar neurons have one axon and one dendrite, found in the retina of eye. So, (C) matches with (IV)
- Multipolar neurons have one axon and two or more dendrites, found in the cerebral cortex. So, (D) matches with (II)

Option (2), (3) and (4) are incorrect as they have mismatches for (A), (B), (C) and (D)

182. Diuresis is prevented by:

- (1) Renin from JG cell via switching off the osmoreceptors
- (2) ANF from atria of the heart
- (3) Aldosterone from adrenal medulla
- (4) Vasopressin from Neurohypophysis

**Answer (4)**

**Sol.** The correct answer is option (4) because,

- Diuresis is prevented by vasopressin or anti-diuretic hormone from neurohypophysis or posterior pituitary. When there is excessive loss of fluid from the body the secretion of, ADH facilitates water reabsorption from latter part of renal tubules.
- Option (1) is incorrect because renin from JG cells convert angiotensinogen in blood to angiotensin I and further to angiotensin II; which is a powerful vasoconstrictor and increases the glomerular blood pressure and thereby GFR.
- Option (2) is incorrect because ANF causes vasodilation and thereby decrease GFR.
- Option (3) is incorrect because aldosterone is released from adrenal cortex and causes reabsorption of Na<sup>+</sup> and water from distal parts of renal tubules.

183. Following is the list of STDs. Select the diseases which are not completely curable.

- |                   |                   |
|-------------------|-------------------|
| A. Genital warts  | B. Genital herpes |
| C. Syphilis       | D. Hepatitis-B    |
| E. Trichomoniasis |                   |

Choose the correct answer from the options given below:

- (1) A and D only
- (2) B and D only
- (3) A and C only
- (4) D and E only

**Answer (2)**

**Sol.** The correct answer is option (2) -B and D only because except for hepatitis -B, genital herpes and HIV infections, other sexually transmitted diseases are completely curable, if detected early and treated properly.

- Genital warts, syphilis and trichomoniasis are completely curable STDs upon proper detection and treatment.
- Option (1) is incorrect as it includes genital warts
- Option (3) is incorrect as it includes genital warts and syphilis.
- Option (4) is incorrect as it includes trichomoniasis.

Genital warts, genital herpes and hepatitis -B are viral STDs, syphilis is a bacterial and trichomoniasis is a protozoan STD.

184. What is the correct order (old to recent) of periods in Paleozoic era?

- (1) Silurian, Devonian, Permian, Carboniferous
- (2) Silurian, Devonian, Carboniferous, Permian
- (3) Permian, Devonian, Silurian, Carboniferous
- (4) Silurian, Carboniferous, Permian, Devonian

**Answer (2)**

**Sol.** The correct answer is option (2) as the correct order (from old to recent) of periods in Paleozoic era is Silurian, Devonian, Carboniferous, Permian

- Option (1) is incorrect because Permian, is mentioned before (carboniferous).
- Option (3) is incorrect because it is mentioned that Permian is the oldest period of Paleozoic era.
- Option (4) is incorrect because it is mentioned that Devonian is the recent period of Paleozoic era.

185. 'Lub' sound of Heart is caused by the\_\_\_\_\_.

- (1) closure of the semilunar valves
- (2) opening of tricuspid and bicuspid valves
- (3) opening of the semilunar valves
- (4) closure of the tricuspid and bicuspid valves

**Answer (4)**







**Sol.** Failure of segregation of chromatids during cell division-cycle results in the gain or loss of chromosome called aneuploidy.

Aneuploidy occurs due to addition or deletion.

Hence only (B) and (C) are correct

188. Given below are two statements :

**Statement I** : RNA interference takes place in all Eukaryotic organisms as method of cellular defense.

**Statement II** : RNAi involves the silencing of a specific mRNA due to a complementary single-stranded RNA molecule that binds and prevents translation of mRNA

In the light of the above statements, choose the **correct** answer from the options given below.

- (1) **Statement I** is true but **Statement II** is false.
- (2) **Statement I** is false but **Statement II** is true.
- (3) Both **Statement I** and **Statement II** are true.
- (4) Both **Statement I** and **Statement II** are false.

**Answer (1)**

**Sol.** The correct answer is option (1) because **Statement I** is correct which states that RNA interference takes place in all eukaryotic organisms as method of cellular defense and **Statement II** is incorrect which states that RNAi involved the silencing of a specific mRNA due to a complementary ssRNA molecule that binds and prevents translation of mRNA.

In **statement II**, it should be complementary dsRNA molecule that is involved in silencing of a specific mRNA.

Options (2), (3) and (4) are incorrect as they represent wrong answer.

189. Identify the wrong statements :

- (A) Erythropoietin is produced by juxtaglomerular cells of the kidney
- (B) Leydig cells produce Androgens
- (C) Atrial Natriuretic factor, a peptide hormone is secreted by the seminiferous tubules of the testes
- (D) Cholecystokinin is produced by gastrointestinal tract
- (E) Gastrin acts on intestinal wall and helps in the production of pepsinogen

Choose the **most appropriate** answer from the options given below :

- (1) (D) and (E) only
- (2) (A) and (B) only
- (3) (C) and (E) only
- (4) (A) and (C) only

**Answer (3)**

**Sol.** The correct answer is option (3), (C) and (E) only as both are wrong statements.

- Atrial natriuretic factor, a peptide hormone is secreted from the atria of the heart not by the seminiferous tubules of the testes.
- Gastrin acts on the gastric glands not on the intestinal wall and stimulates the secretion of hydrochloric acid and pepsinogen.

Rest statements (A), (B) and (D) are correct statements.

Option (1), (2) and (4) are incorrect because they have either one or two correct statements.

190. Following are the steps involved in the process of PCR.

- A. Annealing
- B. Amplification (~1 billion times)
- C. Denaturation
- D. Treatment with Taq polymerase and deoxynucleotides
- E. Extension

Choose the correct sequence of steps of PCR from the options given below :

- (1) C → A → D → E → B
- (2) A → B → E → D → C
- (3) A → C → E → D → B
- (4) D → B → E → C → A

**Answer (1)**

**Sol.** The correct answer is option (1) as the correct sequence of steps involved in the process of PCR are :

- (C) Denaturation
- (A) Annealing
- (D) Treatment with *Taq* polymerase and deoxynucleotides
- (E) Extension
- (B) Amplification (~1 billion times).

That is C → A → D → E → B

Option (2), (3) and (4) are incorrect as they represent incorrect sequence.

191. Given below are two statements:

**Statements I:** Concentrated urine is formed due to counter current mechanism in nephron.

**Statement II:** Counter current mechanism helps to maintain osmotic gradient in the medullary interstitium.

In the light of the above statements, choose the most appropriate answer from the options given below.

- (1) **Statement I** is correct but **Statement II** is incorrect.
- (2) **Statement I** is incorrect but **Statement II** is correct.
- (3) Both **Statement I** and **Statement II** are correct.
- (4) Both **Statement I** and **Statement II** are incorrect.

**Answer (3)**

**Sol.** The correct answer is option (3) as mammals have the ability to produce a concentrated urine. The Henle's loop and vasa recta play a significant role in this. The flow of filtrate in the two limbs of Henle's loop as well as flow of blood through the two limbs of vasa recta are in a counter current pattern. The proximity between the Henle's loop and vasa recta, as well as the counter current in them help in maintaining the increasing osmolarity towards the inner medullary interstitium, *i.e.*, from 300 mOsmol L<sup>-1</sup> in the cortex to about 1200 mOsmol L<sup>-1</sup> in the inner medulla. So, counter current mechanism of loop of Henle of juxtamedullary nephron participates in concentration of urine.

192. Given below are two statements:

**Statement I:** Concentrically arranged cisternae of Golgi complex are arranged near the nucleus with distinct convex *cis* or maturing and concave *trans* or forming face.

**Statement II:** A number of proteins are modified in the cisternae of Golgi complex before they are released from *cis* face.

In the light of the above statements, choose the **correct** answer from the option given below.

- (1) **Statement I** is true but **Statement II** is false.
- (2) **Statement I** is false but **Statement II** is true.
- (3) Both **Statement I** and **Statement II** are true
- (4) Both **Statement I** and **Statement II** are false

**Answer (4)**

**Sol.** The Golgi cisternae are concentrically arranged near the nucleus with distinct convex *cis* or the forming face and concave *trans* or the maturing face.

A number of proteins synthesised by ribosomes on the endoplasmic reticulum are modified in the cisternae of the Golgi apparatus before they are released from its *trans* face.

Hence the correct answer is option (4).

193. Match **List-I** with **List-II**:

	<b>List I</b>		<b>List II</b>
A.	Parturition	I.	Several antibodies for new-born babies
B.	Placenta	II.	Collection of ovum after ovulation
C.	Colostrum	III.	Foetal ejection reflex
D.	Fimbriae	IV.	Secretion of the hormone hCG

Choose the correct answer from the option given below:

- (1) A-III, B-IV, C-I, D-II
- (2) A-I, B-IV, C-II, D-III
- (3) A-II, B-III, C-IV, D-I
- (4) A-III, B-IV, C-II, D-I

**Answer (1)**

**Sol.** The correct answer is option (1) as

- Parturition is induced by a complex neuroendocrine mechanism. The signals for parturition originate from the fully developed foetus and the placenta that induce mild uterine contractions called foetal ejection reflex.
- Placenta acts as an endocrine tissue and produces several hormones like hCG, hPL, estrogens, progesterone, etc.
- The milk produced during the initial few days of lactation is called colostrum that contains several antibodies absolutely necessary to develop resistance for the new-born babies.

Fimbriae helps in collection of the ovum after ovulation.

194. Given below are two statements: One is labelled as **Assertion A** and the other is labelled as **Reason R**.

**Assertion A:** Members of subphylum vertebrata possess notochord during the embryonic period. The notochord is replaced by a cartilaginous or bony vertebral column in the adult.

**Reason R:** Thus all chordates are vertebrates not all vertebrates are chordates.

In the light of the above statements choose the correct answer from the option given below.

- (1) **A** is true but **R** is false.
- (2) **A** is false but **R** is true
- (3) Both **A** and **R** are true and **R** is the correct explanation of **A**.
- (4) Both **A** and **R** are true but **R** is NOT the correct explanation of **A**.

**Answer (1)**

**Sol.** The correct answer is option (1) as Phylum Chordata is divided into three subphyla: Urochordata, Cephalochordata and Vertebrata. The members of subphylum Vertebrata possess notochord during the embryonic period. The notochord is replaced by a cartilaginous or bony vertebral column in the adult. Thus, all vertebrates are chordates but all chordates are not vertebrates.

195. The mother has A+ blood group the father has B+ and the child is A+. What can be the possibility of genotypes of all three, respectively?

- (A)  $I^A I^A \mid I^B i \mid I^B i$
- (B)  $I^A I^A \mid I^B i \mid I^A i$
- (C)  $I^B i \mid I^A I^A \mid I^A I^B$
- (D)  $I^A I^A \mid I^B I^B \mid I^A i$
- (E)  $I^A i \mid I^B i \mid I^A i$

Choose the **correct** answer from the option given below:

- (1) C and D
- (2) D and A
- (3) A and B
- (4) B and E

**Answer (4)**

**Sol.** The child blood group is (A+) that means he must have received (*i*) allele from the father i.e. the father genotype is ( $I^B i$ ).

While mother can have  $I^A I^A$  or  $I^A i$  genotype.

So, the possible genotypes of all three i.e. mother, father and child respectively would be either

- (B)  $I^A I^A \mid I^B i \mid I^A i$
- (E)  $I^A i \mid I^B i \mid I^A i$

196. What do 'a' and 'b' represent in the following population growth curve?

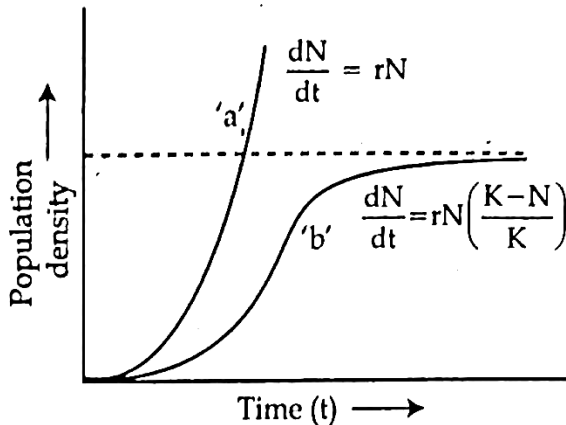

- (1) 'a' represents exponential growth when responses are not limiting the growth; and 'b' represents logistic growth when responses are limiting the growth.
- (2) 'a' represents logistic growth when responses are not limiting the growth; 'b' represents exponential growth when responses are limiting the growth.
- (3) 'a' represents carrying capacity and 'b' shows logistic growth when responses are limiting the growth.
- (4) 'a' represents exponential growth when responses are not limiting the growth and 'b' shows carrying capacity.

**Answer (1)**

**Sol.** The given graph represents the population growth curve where 'a' represents exponential growth when responses are not limiting the growth which forms a J-shaped curve and 'b' represents logistic growth when responses are limiting the growth which forms an S-shaped curve.

197. Select the correct statements regarding mechanism of muscle contraction.

- A. It is initiated by a signal sent by CNS via sensory neuron.
- B. Neurotransmitter generates action potential in the sarcolemma.
- C. Increased  $\text{Ca}^{2+}$  level leads to the binding of calcium with troponin on action filaments.
- D. Masking of active site for actin is activated.
- E. Utilising the energy from ATP hydrolysis to form cross bridge.

Choose the most appropriate answer from the options given below:

- (1) B, C and E only
- (2) C, D and E only
- (3) A and D only
- (4) B, D and E only

**Answer (1)**

**Sol.** The correct answer is option (1) as muscle contraction is initiated by a signal sent by the CNS via a motor neuron. A neural signal reaching the neuromuscular junction releases a neurotransmitter (acetylcholine) which generates an action potential in the sarcolemma. This spreads through the muscle fibre and causes the release of  $\text{Ca}^{2+}$  into the sarcoplasm. Increase in  $\text{Ca}^{2+}$  level leads to the binding of calcium with a subunit of troponin on actin filaments and thereby remove the masking of active sites for myosin. Utilising the energy from ATP hydrolysis, the myosin head now binds to the exposed active sites on actin to form a cross bridge.



200. Given below are two statements: One is labelled as Assertion A and the other is labelled as Reason R.

**Assertion A:** During the transportation of gases, about 20-25 percent of  $\text{CO}_2$  is carried by Haemoglobin as carbamino-haemoglobin.

**Reason R:** This binding is related to high  $\text{pCO}_2$  and low  $\text{pO}_2$  in tissues.

In the light of the above statements, choose the correct answer from the options given below.

- (1) A is true but R is false.
- (2) A is false but R is true.
- (3) Both A and R are true and R is the correct explanation of A.
- (4) Both A and R are true but R is NOT the correct explanation of A.

**Answer (3)**

**Sol.** The correct answer is option (3) as nearly 20-25 percent of  $\text{CO}_2$  is transported by RBCs whereas 70 percent of it is carried as bicarbonate. About 7 percent of  $\text{CO}_2$  is carried in a dissolved state through plasma.

The binding of  $\text{CO}_2$  with haemoglobin is related to the partial pressure of  $\text{CO}_2$ .  $\text{pO}_2$  is a major factor which could affect this binding. When  $\text{pCO}_2$  is high and  $\text{pO}_2$  is low as in the tissues, more binding of  $\text{CO}_2$  occurs. Percentage of a gas transported depends upon its partial pressure. If partial pressure decreases, the transportation of gases also decrease with haemoglobin. So, Reason is the correct explanation of Assertion.

