

Telangana State Council Higher Education

Notations :

- 1.Options shown in green color and with ✓ icon are correct.
- 2.Options shown in red color and with ✗ icon are incorrect.

Question Paper Name :	Electronics and Communication Engineering 30th May 2023 Shift1
Subject Name :	Electronics and Communication Engineering
Creation Date :	2023-05-30 13:11:08
Duration :	120
Total Marks :	120
Display Marks:	No
Share Answer Key With Delivery Engine :	Yes
Actual Answer Key :	Yes
Calculator :	None
Magnifying Glass Required? :	No
Ruler Required? :	No
Eraser Required? :	No
Scratch Pad Required? :	No
Rough Sketch/Notepad Required? :	No
Protractor Required? :	No
Show Watermark on Console? :	Yes
Highlighter :	No
Auto Save on Console?	Yes
Change Font Color :	No
Change Background Color :	No
Change Theme :	No

Help Button :	No
Show Reports :	No
Show Progress Bar :	No

Electronics and Communication Engineering

Group Number :	1
Group Id :	28393663
Group Maximum Duration :	0
Group Minimum Duration :	120
Show Attended Group? :	No
Edit Attended Group? :	No
Break time :	0
Group Marks :	120
Is this Group for Examiner? :	No
Examiner permission :	Cant View
Show Progress Bar? :	No

Mathematics

Section Id :	283936176
Section Number :	1
Section type :	Online
Mandatory or Optional :	Mandatory
Number of Questions :	10
Number of Questions to be attempted :	10
Section Marks :	10
Enable Mark as Answered Mark for Review and Clear Response :	Yes
Maximum Instruction Time :	0

Sub-Section Number : 1
Sub-Section Id : 283936176
Question Shuffling Allowed : Yes
Is Section Default? : null

Question Number : 1 Question Id : 2839368921 Question Type : MCQ Option Shuffling : Yes
Display Question Number : Yes Is Question Mandatory : No Calculator : None Response Time : N.A Think Time : N.A Minimum Instruction Time : 0

Correct Marks : 1 Wrong Marks : 0

The system of equations $4x+9y+3z=6$, $2x+3y+z=2$ and $2x+6y+2z=7$ has

Options :

1. ✘ a unique solution
2. ✔ no solution
3. ✘ infinitely many solutions
4. ✘ three solutions

Question Number : 2 Question Id : 2839368922 Question Type : MCQ Option Shuffling : Yes
Display Question Number : Yes Is Question Mandatory : No Calculator : None Response Time : N.A Think Time : N.A Minimum Instruction Time : 0

Correct Marks : 1 Wrong Marks : 0

If 5 is an eigenvalue of the matrix $A = \begin{pmatrix} 2 & 2 & 1 \\ 1 & 3 & 1 \\ 1 & 2 & 2 \end{pmatrix}$, then the corresponding eigenvector is

Options :

1. ✘

$$\begin{pmatrix} 1 \\ -1 \\ -1 \end{pmatrix}$$

2. ✘ $\begin{pmatrix} 1 \\ 2 \\ 1 \end{pmatrix}$

3. ✔ $\begin{pmatrix} 1 \\ 1 \\ 1 \end{pmatrix}$

4. ✘ $\begin{pmatrix} -1 \\ 1 \\ 2 \end{pmatrix}$

Question Number : 3 Question Id : 2839368923 Question Type : MCQ Option Shuffling : Yes Display Question Number : Yes Is Question Mandatory : No Calculator : None Response Time : N.A Think Time : N.A Minimum Instruction Time : 0

Correct Marks : 1 Wrong Marks : 0

The value of c of the Cauchy's mean value theorem for the functions e^{-x} and e^x in $[4, 8]$ is

Options :

1. ✔ 6

2. ✘ 5

3. ✘ 3.5

4. ✘ 6.5

Question Number : 4 Question Id : 2839368924 Question Type : MCQ Option Shuffling : Yes
Display Question Number : Yes Is Question Mandatory : No Calculator : None Response Time
: N.A Think Time : N.A Minimum Instruction Time : 0

Correct Marks : 1 Wrong Marks : 0

If $\vec{F} = 2x\vec{i} + 3y\vec{j} + 4z\vec{k}$ and S is the surface of the unit sphere, then $\iint_S \vec{F} \cdot \vec{n} \, ds =$

Options :

1. ✘ $\frac{2\pi}{3}$

2. ✘ $\frac{4\pi}{3}$

3. ✔ 12π

4. ✘ 4π

Question Number : 5 Question Id : 2839368925 Question Type : MCQ Option Shuffling : Yes
Display Question Number : Yes Is Question Mandatory : No Calculator : None Response Time
: N.A Think Time : N.A Minimum Instruction Time : 0

Correct Marks : 1 Wrong Marks : 0

A particular integral of $y'' + 2y' + y = e^{-x} \cos x$ is $ke^{-x} \cos x$. Then $k =$

Options :

1. ✔ -1

2. ✘ 1

3. ✘ $\frac{1}{2}$

4. ✘ $-\frac{1}{2}$

Question Number : 6 Question Id : 2839368926 Question Type : MCQ Option Shuffling : Yes
Display Question Number : Yes Is Question Mandatory : No Calculator : None Response Time
: N.A Think Time : N.A Minimum Instruction Time : 0

Correct Marks : 1 Wrong Marks : 0

The general solution of $4x^2 y'' + y = 0, x > 0$ is $y =$

Options :

1. ✘ $A + B \log x$

2. ✔ $(A + B \log x) \sqrt{x}$

3. ✘ $(A + B \log x) e^{\sqrt{x}}$

4. ✘ $(A + Bx) e^{2x}$

Question Number : 7 Question Id : 2839368927 Question Type : MCQ Option Shuffling : Yes
Display Question Number : Yes Is Question Mandatory : No Calculator : None Response Time
: N.A Think Time : N.A Minimum Instruction Time : 0

Correct Marks : 1 Wrong Marks : 0

The real part of the analytic function whose imaginary part is $e^x (x \sin y + y \cos y)$

Options :

1. ✓ $e^x(x \cos y - y \sin y)$

2. ✗ $e^x(x \cos y + y \sin y)$

3. ✗ $e^x(x \sin y - y \sin y)$

4. ✗ $e^x(\cos y - \sin y)$

Question Number : 8 Question Id : 2839368928 Question Type : MCQ Option Shuffling : Yes
Display Question Number : Yes Is Question Mandatory : No Calculator : None Response Time
: N.A Think Time : N.A Minimum Instruction Time : 0

Correct Marks : 1 Wrong Marks : 0

A teacher chooses a student at random from a class of 30 girls. The probability that the student chosen is a girl is

Options :

1. ✗ 0

2. ✗ $\frac{1}{30}$

3. ✓ 1

4. ✗ $\frac{1}{15}$

Question Number : 9 Question Id : 2839368929 Question Type : MCQ Option Shuffling : Yes
Display Question Number : Yes Is Question Mandatory : No Calculator : Non

: N.A Think Time : N.A Minimum Instruction Time : 0

Correct Marks : 1 Wrong Marks : 0

A random variable X has the following probability distribution:

X	1	2	3	4
$P(X)$	$\frac{1}{10}$	$\frac{1}{5}$	$\frac{3}{10}$	$\frac{2}{5}$

The value of $P(X \leq 3) - P(X = 4)$ is

Options :

1. ✓ $\frac{1}{5}$

2. ✗ $\frac{2}{5}$

3. ✗ $\frac{3}{10}$

4. ✗ 0

Question Number : 10 Question Id : 2839368930 Question Type : MCQ Option Shuffling : Yes

Display Question Number : Yes Is Question Mandatory : No Calculator : None Response Time

: N.A Think Time : N.A Minimum Instruction Time : 0

Correct Marks : 1 Wrong Marks : 0

Which of the following intervals contains the smallest positive root of $x^5 - 2x - 3 = 0$?

Options :

1. ✗ $(0, 1)$

2. ✗ $(2, 3)$

3. ✘ (3, 4)

4. ✔ (1, 2)

Electronics and Communication Engineering

Section Id :	283936177
Section Number :	2
Section type :	Online
Mandatory or Optional :	Mandatory
Number of Questions :	110
Number of Questions to be attempted :	110
Section Marks :	110
Enable Mark as Answered Mark for Review and Clear Response :	Yes
Maximum Instruction Time :	0
Sub-Section Number :	1
Sub-Section Id :	283936177
Question Shuffling Allowed :	Yes
Is Section Default? :	null

Question Number : 11 Question Id : 2839368931 Question Type : MCQ Option Shuffling : Yes
Display Question Number : Yes Is Question Mandatory : No Calculator : None Response Time : N.A Think Time : N.A Minimum Instruction Time : 0
Correct Marks : 1 Wrong Marks : 0

The current I in the circuit of Fig. is:

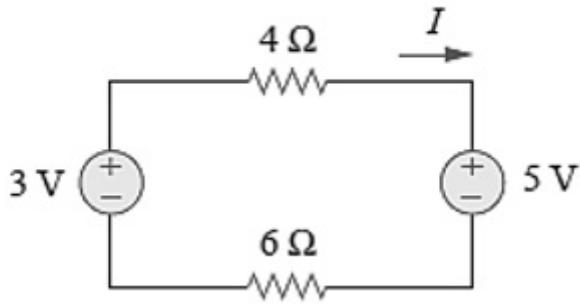

Options :

1. ✘ -0.8 A
2. ✔ - 0.2 A
3. ✘ 0.2 A
4. ✘ 0.8 A

Question Number : 12 Question Id : 2839368932 Question Type : MCQ Option Shuffling : Yes
Display Question Number : Yes Is Question Mandatory : No Calculator : None Response Time
: N.A Think Time : N.A Minimum Instruction Time : 0

Correct Marks : 1 Wrong Marks : 0

A super node is formed by enclosing a dependent or independent voltage source connected between two -----nodes and elements connected in -----with it.

Options :

1. ✘ non-reference, series
2. ✔ non-reference, parallel
3. ✘ reference, series

4. ✘ reference, parallel

Question Number : 13 Question Id : 2839368933 Question Type : MCQ Option Shuffling : Yes
Display Question Number : Yes Is Question Mandatory : No Calculator : None Response Time : N.A Think Time : N.A Minimum Instruction Time : 0

Correct Marks : 1 Wrong Marks : 0

A connected planar network has 4 nodes and 5 elements, then the number of meshes in its dual network is

Options :

1. ✘ 2

2. ✔ 3

3. ✘ 8

4. ✘ 9

Question Number : 14 Question Id : 2839368934 Question Type : MCQ Option Shuffling : Yes
Display Question Number : Yes Is Question Mandatory : No Calculator : None Response Time : N.A Think Time : N.A Minimum Instruction Time : 0

Correct Marks : 1 Wrong Marks : 0

For the circuit shown in figure, the value of current I is

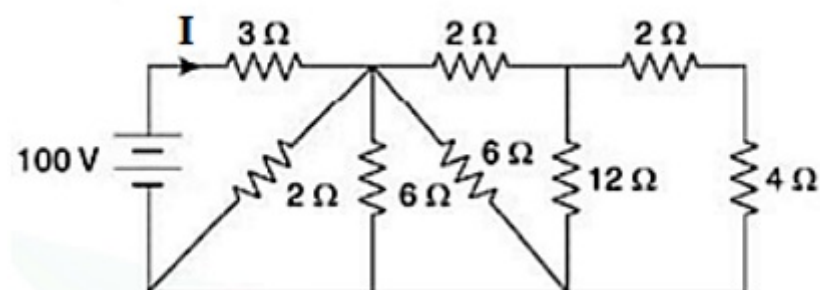

Options :

1. ✘ 10 A

2. ✘ 20A

3. ✘ 22 A

4. ✔ 25 A

Question Number : 15 Question Id : 2839368935 Question Type : MCQ Option Shuffling : Yes Display Question Number : Yes Is Question Mandatory : No Calculator : None Response Time : N.A Think Time : N.A Minimum Instruction Time : 0

Correct Marks : 1 Wrong Marks : 0

When a source is delivering maximum power to a load, the efficiency of the circuit is always

Options :

1. ✔ 50%

2. ✘ 75%

3. ✘ 100 %

4. ✘ depends on the circuit parameters

Question Number : 16 Question Id : 2839368936 Question Type : MCQ Option Shuffling : Yes Display Question Number : Yes Is Question Mandatory : No Calculator : None Response Time : N.A Think Time : N.A Minimum Instruction Time : 0

Correct Marks : 1 Wrong Marks : 0

Superposition theorem is not applicable for

Options :

1. ✘ voltage calculations
2. ✘ bilateral elements
3. ✘ passive elements
4. ✔ power calculations

Question Number : 17 Question Id : 2839368937 Question Type : MCQ Option Shuffling : Yes
Display Question Number : Yes Is Question Mandatory : No Calculator : None Response Time : N.A Think Time : N.A Minimum Instruction Time : 0

Correct Marks : 1 Wrong Marks : 0

The Thevenin resistance at terminals a and b is:

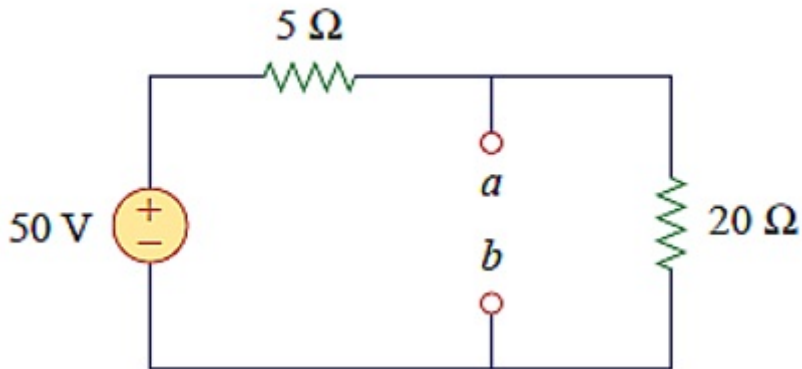

Options :

1. ✘ 25 Ω
2. ✘ 20 Ω
3. ✘ 5 Ω

4. ✓ 4Ω

Question Number : 18 Question Id : 2839368938 Question Type : MCQ Option Shuffling : Yes
Display Question Number : Yes Is Question Mandatory : No Calculator : None Response Time
: N.A Think Time : N.A Minimum Instruction Time : 0

Correct Marks : 1 Wrong Marks : 0

Transient current in an RLC circuit is oscillatory when

Options :

1. ✓ $R < 2\sqrt{\frac{L}{C}}$

2. ✗ $R > 2\sqrt{\frac{L}{C}}$

3. ✗ $R < 2\sqrt{\frac{C}{L}}$

4. ✗ $R > 2\sqrt{\frac{C}{L}}$

Question Number : 19 Question Id : 2839368939 Question Type : MCQ Option Shuffling : Yes
Display Question Number : Yes Is Question Mandatory : No Calculator : None Response Time
: N.A Think Time : N.A Minimum Instruction Time : 0

Correct Marks : 1 Wrong Marks : 0

A delta connection contains three equal resistances of 6 ohms. The resistances of the
equivalent star connection will be

Options :

1. ✗ 3 ohm

2. ✓ 2 ohm

3. ✗ 12 ohm

4. ✗ 18 ohm

Question Number : 20 Question Id : 2839368940 Question Type : MCQ Option Shuffling : Yes Display Question Number : Yes Is Question Mandatory : No Calculator : None Response Time : N.A Think Time : N.A Minimum Instruction Time : 0

Correct Marks : 1 Wrong Marks : 0

The driving point admittance $Y_{11}(s)$ of the following network is

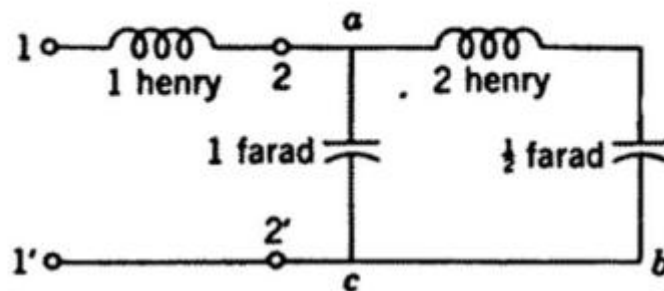

Options :

1. ✗ $\frac{s^2+s}{s^4+2}$

2. ✗ $\frac{s^2+s+2}{s^4+s^2+2}$

3. ✓ $\frac{2s^2+3s}{2s^4+5s^2+2}$

4. ✗ $\frac{3s}{s^2+4}$

Question Number : 21 Question Id : 2839368941 Question Type : MCQ Option Shuffling : Yes
Display Question Number : Yes Is Question Mandatory : No Calculator : None Response Time : N.A Think Time : N.A Minimum Instruction Time : 0

Correct Marks : 1 Wrong Marks : 0

The signal power for a complex signal $f(t)$ is

Options :

1. ✓ $\lim_{T \rightarrow \infty} \frac{1}{T} \int_{-T/2}^{T/2} |f(t)|^2 dt$

2. ✗ $\int_{-T/2}^{T/2} \{f(t)\}^2 dt$

3. ✗ $\lim_{T \rightarrow \infty} \frac{1}{T} \int_{-T/2}^{T/2} |f^*(t)|^2 dt$

4. ✗ $|f^*(t)|^2$

Question Number : 22 Question Id : 2839368942 Question Type : MCQ Option Shuffling : Yes
Display Question Number : Yes Is Question Mandatory : No Calculator : None Response Time : N.A Think Time : N.A Minimum Instruction Time : 0

Correct Marks : 1 Wrong Marks : 0

For a signal $f(t)$ shown in figure below, write a mathematical expression with time compressed factor of 3.

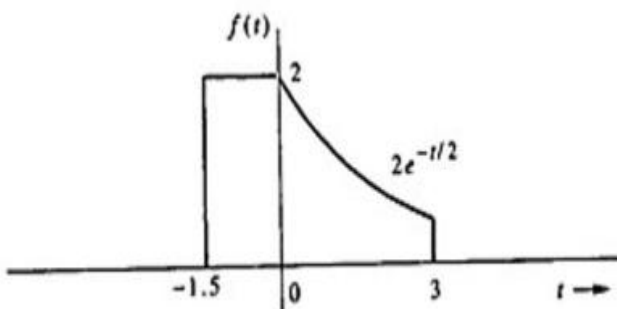

Options :

$$1. \times \begin{cases} 2 & -1.5 \leq t < 0 \\ 2e^{-\frac{3t}{2}} & 0 \leq t < 3 \end{cases}$$

$$2. \times \begin{cases} 2e^{-2t} & 0 \leq t < -1.5 \\ 2e^{-\frac{t}{2}} & 0 \leq t < 3 \\ 0 & \text{otherwise} \end{cases}$$

$$3. \times \begin{cases} 2t & -0.5 \leq t < 0 \\ 2e^{-\frac{3t}{2}} & 0 \leq t < 3 \\ 0 & \text{otherwise} \end{cases}$$

$$4. \checkmark \begin{cases} 2 & -0.5 \leq t < 0 \\ 2e^{-\frac{3t}{2}} & 0 \leq t < 1 \\ 0 & \text{otherwise} \end{cases}$$

Question Number : 23 Question Id : 2839368943 Question Type : MCQ Option Shuffling : Yes
 Display Question Number : Yes Is Question Mandatory : No Calculator : None Response Time
 : N.A Think Time : N.A Minimum Instruction Time : 0

Correct Marks : 1 Wrong Marks : 0

The area under the product of a function with an impulse is equal to the value of that function at the instant where the unit impulse is located then this property is known as

Options :

1. \times periodic

2. \checkmark sampling

3. \times additive

4. ✘ multiplicative

Question Number : 24 Question Id : 2839368944 Question Type : MCQ Option Shuffling : Yes Display Question Number : Yes Is Question Mandatory : No Calculator : None Response Time : N.A Think Time : N.A Minimum Instruction Time : 0

Correct Marks : 1 Wrong Marks : 0

Which of the following is wrong with respect to the existence of Fourier Series?

Options :

1. ✘ The coefficients must be finite
2. ✘ Given function is absolutely integrable over one period
3. ✔ The series converge at every point
4. ✘ Given function have only a finite number of maxima and minima in one period

Question Number : 25 Question Id : 2839368945 Question Type : MCQ Option Shuffling : Yes Display Question Number : Yes Is Question Mandatory : No Calculator : None Response Time : N.A Think Time : N.A Minimum Instruction Time : 0

Correct Marks : 1 Wrong Marks : 0

The Fourier series can be used only for periodic inputs. Which one of the following is to be considered to overcome this limitation?

Options :

1. ✔ Representing aperiodic signals in terms of everlasting exponentials

Using e^{st} where s is not restricted to the imaginary axis, but is free to take on

2. ✘ complex values
3. ✘ Using the Laplace integral
4. ✘ Using Fourier differentiation

Question Number : 26 Question Id : 2839368946 Question Type : MCQ Option Shuffling : Yes Display Question Number : Yes Is Question Mandatory : No Calculator : None Response Time : N.A Think Time : N.A Minimum Instruction Time : 0

Correct Marks : 1 Wrong Marks : 0

Fourier transform of the function $e^{-t^2/2\sigma^2}$ is

Options :

1. ✘ $\sigma e^{-\sigma^2}$
2. ✔ $\sigma\sqrt{2\pi}e^{-\sigma^2 w^2/2}$
3. ✘ $\sigma\sqrt{2\pi}$
4. ✘ $e^{-\sigma^2 w^2/\pi}$

Question Number : 27 Question Id : 2839368947 Question Type : MCQ Option Shuffling : Yes Display Question Number : Yes Is Question Mandatory : No Calculator : None Response Time : N.A Think Time : N.A Minimum Instruction Time : 0

Correct Marks : 1 Wrong Marks : 0

Symmetry property states that if $f(t) \leftrightarrow F(w)$ then

Options :

1. ✘ $f(t) \leftrightarrow F(-w)$

2. ✔ $F(t) \leftrightarrow 2\pi f(-w)$

3. ✘ $F(w) \leftrightarrow 2\pi f(-t)$

4. ✘ $F(w) \leftrightarrow \frac{2}{\pi} f(t)$

Question Number : 28 Question Id : 2839368948 Question Type : MCQ Option Shuffling : Yes Display Question Number : Yes Is Question Mandatory : No Calculator : None Response Time : N.A Think Time : N.A Minimum Instruction Time : 0

Correct Marks : 1 Wrong Marks : 0

The signal with bandwidth B can be recovered from its samples by passing the sampled signal through an ideal

Options :

1. ✘ low pass filter of bandwidth B

2. ✔ low pass filter of bandwidth 2B

3. ✘ high pass filter of bandwidth B

4. ✘ high pass filter of bandwidth 2B

Question Number : 29 Question Id : 2839368949 Question Type : MCQ Option Shuffling : Yes Display Question Number : Yes Is Question Mandatory : No Calculator : None Response Time : N.A Think Time : N.A Minimum Instruction Time : 0

Correct Marks : 1 Wrong Marks : 0

A discrete-time system to be asymptotically stable if and only if the zero-input response

Options :

1. ✘ approaches a constant with a constant amplitude
2. ✘ grows without bound as $k \rightarrow \infty$
3. ✔ approaches zero as $k \rightarrow \infty$
4. ✘ neither approaches zero nor grows without bound, but remains within a finite limit as $k \rightarrow \infty$

**Question Number : 30 Question Id : 2839368950 Question Type : MCQ Option Shuffling : Yes
Display Question Number : Yes Is Question Mandatory : No Calculator : None Response Time
: N.A Think Time : N.A Minimum Instruction Time : 0**

Correct Marks : 1 Wrong Marks : 0

The Fourier integral is basically a Fourier series with fundamental frequency
approaching

Options :

1. ✔ 0
2. ✘ 1
3. ✘ π
4. ✘ ∞

**Question Number : 31 Question Id : 2839368951 Question Type : MCQ Option Shuffling : Yes
Display Question Number : Yes Is Question Mandatory : No Calculator : Non**

: N.A Think Time : N.A Minimum Instruction Time : 0

Correct Marks : 1 Wrong Marks : 0

The z-transform of the function $f(k)$ shown in figure is

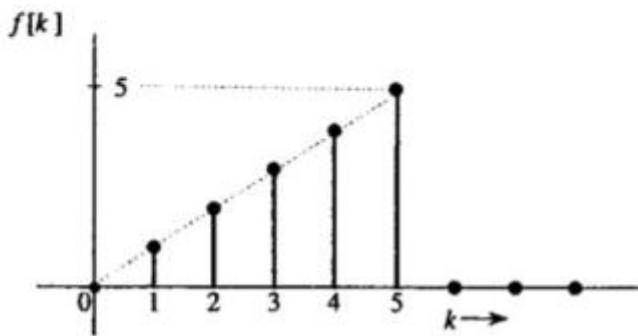

Options :

1. ✘ $\frac{z^4 - z + 6}{z^5(z-1)^4}$

2. ✘ $\frac{z^5 - z}{z^6(z-1)^3}$

3. ✔ $\frac{z^6 - 6z + 5}{z^5(z-1)^2}$

4. ✘ $\frac{z^5 - z}{z^5(z-1)^5}$

Question Number : 32 Question Id : 2839368952 Question Type : MCQ Option Shuffling : Yes

Display Question Number : Yes Is Question Mandatory : No Calculator : None Response Time

: N.A Think Time : N.A Minimum Instruction Time : 0

Correct Marks : 1 Wrong Marks : 0

The z-transform changes the difference equations of LTI Discrete Time (LTID) system into

Options :

1. ✘ logic equations

2. ✘ arithmetic expressions

3. ✘ differential equations

4. ✔ algebraic equations

Question Number : 33 Question Id : 2839368953 Question Type : MCQ Option Shuffling : Yes Display Question Number : Yes Is Question Mandatory : No Calculator : None Response Time : N.A Think Time : N.A Minimum Instruction Time : 0

Correct Marks : 1 Wrong Marks : 0

LTID systems can be realized by

Options :

1. ✔ scalar multipliers, summers, time delays

2. ✘ scalar dividers, subtracters, limiters

3. ✘ vector multipliers, subtracters, amplifiers

4. ✘ vector dividers, summers, attenuators

Question Number : 34 Question Id : 2839368954 Question Type : MCQ Option Shuffling : Yes Display Question Number : Yes Is Question Mandatory : No Calculator : None Response Time : N.A Think Time : N.A Minimum Instruction Time : 0

Correct Marks : 1 Wrong Marks : 0

In pole-zero placement method, poles are located at near points of unit circle corresponding to frequencies to be ___ and to place zeros near the frequencies to be ____

Options :

1. ✘ emphasized, emphasized
2. ✘ deemphasized, deemphasized
3. ✔ emphasized, deemphasized
4. ✘ deemphasized, emphasized

**Question Number : 35 Question Id : 2839368955 Question Type : MCQ Option Shuffling : Yes
Display Question Number : Yes Is Question Mandatory : No Calculator : None Response Time
: N.A Think Time : N.A Minimum Instruction Time : 0**

Correct Marks : 1 Wrong Marks : 0

Maximum-phase system has

Options :

1. ✘ minimum delay characteristics
2. ✔ all the zeros outside the unit circle
3. ✘ all the zeros inside the unit circle
4. ✘ some of the zeros are inside and remaining are outside of the unit circle

**Question Number : 36 Question Id : 2839368956 Question Type : MCQ Option Shuffling : Yes
Display Question Number : Yes Is Question Mandatory : No Calculator : None Response Time
: N.A Think Time : N.A Minimum Instruction Time : 0**

Correct Marks : 1 Wrong Marks : 0

An intrinsic silicon bar has a rectangular cross-section $50 \times 100 \mu\text{m}$, resistivity of $2.3 \times 10^5 \Omega\text{-cm}$ at 300K , then determine the electric field intensity in the bar when a steady current of $1\mu\text{A}$ is measured.

Options :

1. ✓ 4600 V/cm
2. ✗ 4600 V/m
3. ✗ 1380 V/m
4. ✗ 1380 V/cm

Question Number : 37 Question Id : 2839368957 Question Type : MCQ Option Shuffling : Yes Display Question Number : Yes Is Question Mandatory : No Calculator : None Response Time : N.A Think Time : N.A Minimum Instruction Time : 0

Correct Marks : 1 Wrong Marks : 0

Which of the following is not an acceptor to form a p-type semiconductor?

Options :

1. ✗ Boron
2. ✗ Gallium
3. ✗ Indium
4. ✓ Arsenic

Question Number : 38 Question Id : 2839368958 Question Type : MCQ Option

Display Question Number : Yes Is Question Mandatory : No Calculator : None Response Time : N.A Think Time : N.A Minimum Instruction Time : 0

Correct Marks : 1 Wrong Marks : 0

By increasing the reverse current, which of the following breakdown occur?

Options :

1. ✘ Schottky

2. ✘ tunnel

3. ✔ Zener

4. ✘ avalanche

Question Number : 39 Question Id : 2839368959 Question Type : MCQ Option Shuffling : Yes Display Question Number : Yes Is Question Mandatory : No Calculator : None Response Time : N.A Think Time : N.A Minimum Instruction Time : 0

Correct Marks : 1 Wrong Marks : 0

The channel is the one through which

Options :

1. ✘ minority carriers move between source and gate

2. ✔ majority carriers move between source and drain

3. ✘ minority carriers move between emitter and collector

4. ✘ majority carriers move between base and emitter

Question Number : 40 Question Id : 2839368960 Question Type : MCQ Option Shuffling : Yes
Display Question Number : Yes Is Question Mandatory : No Calculator : None Response Time
: N.A Think Time : N.A Minimum Instruction Time : 0

Correct Marks : 1 Wrong Marks : 0

Which of the following is the disadvantage of IC technology as compared with discrete components interconnected by conventional techniques?

Options :

1. ✘ Low cost
2. ✘ Small size
3. ✔ Low reliability
4. ✘ Matched devices

Question Number : 41 Question Id : 2839368961 Question Type : MCQ Option Shuffling : Yes
Display Question Number : Yes Is Question Mandatory : No Calculator : None Response Time
: N.A Think Time : N.A Minimum Instruction Time : 0

Correct Marks : 1 Wrong Marks : 0

In IC fabrication, which of the process is used for the extension of an existing crystal wafer?

Options :

1. ✘ Oxidation
2. ✔ Epitaxial growth
3. ✘ Photolithography
- 4.

✘ Metallization

Question Number : 42 Question Id : 2839368962 Question Type : MCQ Option Shuffling : Yes
Display Question Number : Yes Is Question Mandatory : No Calculator : None Response Time
: N.A Think Time : N.A Minimum Instruction Time : 0

Correct Marks : 1 Wrong Marks : 0

A photolithographic process defines the

Options :

1. ✘ source region
2. ✘ drain region
3. ✓ gate region
4. ✘ substrate

Question Number : 43 Question Id : 2839368963 Question Type : MCQ Option Shuffling : Yes
Display Question Number : Yes Is Question Mandatory : No Calculator : None Response Time
: N.A Think Time : N.A Minimum Instruction Time : 0

Correct Marks : 1 Wrong Marks : 0

The use of polysilicon gates ----- the threshold voltage, as a result -----supply
voltages can be used.

Options :

1. ✘ reduces, higher
2. ✓ reduces, lower

3. ✘ increases, higher

4. ✘ increases, lower

Question Number : 44 Question Id : 2839368964 Question Type : MCQ Option Shuffling : Yes Display Question Number : Yes Is Question Mandatory : No Calculator : None Response Time : N.A Think Time : N.A Minimum Instruction Time : 0

Correct Marks : 1 Wrong Marks : 0

In which region, a linear change in base current produces a nearly linear collector-emitter voltage change?

Options :

1. ✘ Cut-off region

2. ✘ Pinch-off region

3. ✔ Active region

4. ✘ Saturation region

Question Number : 45 Question Id : 2839368965 Question Type : MCQ Option Shuffling : Yes Display Question Number : Yes Is Question Mandatory : No Calculator : None Response Time : N.A Think Time : N.A Minimum Instruction Time : 0

Correct Marks : 1 Wrong Marks : 0

Match the following:

A. Drift current due to holes

I. $qD_n \frac{dn}{dx}$ (in $\frac{A}{m^2}$)

B. Diffusion current due to electrons

II. $h_{FE}I_b$

C. Collector current

III. $I_R - I_L$

D. Zener current

IV. $q\mu_p nE$ (in $\frac{A}{m^2}$)

Options :

1. ✓ A – IV, B – I, C – II, D – III

2. ✗ A – I, B – II, C – III, D – IV

3. ✗ A – III, B – IV, C – I, D – II

4. ✗ A – II, B – III, C – IV, D – I

Question Number : 46 Question Id : 2839368966 Question Type : MCQ Option Shuffling : Yes
Display Question Number : Yes Is Question Mandatory : No Calculator : None Response Time
: N.A Think Time : N.A Minimum Instruction Time : 0

Correct Marks : 1 Wrong Marks : 0

The output signal voltage often serves as the input to another amplifier stage without affecting its bias because of the

Options :

1. ✗ blocking capacitance at input

2. ✓ coupling capacitance at output

3. ✗ bypass capacitance at emitter

4. ✘ load resistance

Question Number : 47 Question Id : 2839368967 Question Type : MCQ Option Shuffling : Yes
Display Question Number : Yes Is Question Mandatory : No Calculator : None Response Time
: N.A Think Time : N.A Minimum Instruction Time : 0

Correct Marks : 1 Wrong Marks : 0

The amplification factor in FET amplifier is

Options :

1. ✘ $\mu = g_m/r_d$

2. ✘ $\mu = r_d/g_m$

3. ✘ $\mu = \sqrt{r_d g_m}$

4. ✔ $\mu = g_m r_d$

Question Number : 48 Question Id : 2839368968 Question Type : MCQ Option Shuffling : Yes
Display Question Number : Yes Is Question Mandatory : No Calculator : None Response Time
: N.A Think Time : N.A Minimum Instruction Time : 0

Correct Marks : 1 Wrong Marks : 0

The rise time of an amplifier with 1MHz upper 3dB frequency is

Options :

1. ✘ 0.001 ms

2. ✘ 0.005 ms

3. ✔ 0.35 μ s

4. ✘ 1.414 μs

Question Number : 49 Question Id : 2839368969 Question Type : MCQ Option Shuffling : Yes
Display Question Number : Yes Is Question Mandatory : No Calculator : None Response Time
: N.A Think Time : N.A Minimum Instruction Time : 0

Correct Marks : 1 Wrong Marks : 0

The frequency at which the common emitter short circuit current gain has unit magnitude is represented by

Options :

1. ✘ f_{α}

2. ✘ f_{β}

3. ✘ f_{δ}

4. ✔ f_T

Question Number : 50 Question Id : 2839368970 Question Type : MCQ Option Shuffling : Yes
Display Question Number : Yes Is Question Mandatory : No Calculator : None Response Time
: N.A Think Time : N.A Minimum Instruction Time : 0

Correct Marks : 1 Wrong Marks : 0

The architecture of a two-stage op-amp consists of

Options :

1. ✘ Difference amplifier, balanced stage, limiter, CC amplifier

2. ✔ Differential amplifier, gain stage, level shifter, emitter follower

3. ✘ Integrator, limiter, isolator, CE amplifier

4. ✘ Integrator, limiter, level shifter, CB amplifier

Question Number : 51 Question Id : 2839368971 Question Type : MCQ Option Shuffling : Yes
Display Question Number : Yes Is Question Mandatory : No Calculator : None Response Time
: N.A Think Time : N.A Minimum Instruction Time : 0

Correct Marks : 1 Wrong Marks : 0

The slew rate for a type 741 op-amp with $I_C = 9.5\mu\text{A}$, $C_C = 30\text{pF}$, $f_G = 10\text{MHz}$ is

Options :

1. ✔ 0.63 V/ μs

2. ✘ 0.63 V/s

3. ✘ 0.03 V/s

4. ✘ 0.03 V/ μs

Question Number : 52 Question Id : 2839368972 Question Type : MCQ Option Shuffling : Yes
Display Question Number : Yes Is Question Mandatory : No Calculator : None Response Time
: N.A Think Time : N.A Minimum Instruction Time : 0

Correct Marks : 1 Wrong Marks : 0

The Schmitt trigger is

Options :

1. ✘ level indicator

2. ✓ regenerative comparator

3. ✘ blocking oscillator

4. ✘ high gain amplifier

Question Number : 53 Question Id : 2839368973 Question Type : MCQ Option Shuffling : Yes Display Question Number : Yes Is Question Mandatory : No Calculator : None Response Time : N.A Think Time : N.A Minimum Instruction Time : 0

Correct Marks : 1 Wrong Marks : 0

To minimize crossover distortion, the transistors must operate in

Options :

1. ✘ Class A

2. ✘ Class C

3. ✘ Class D

4. ✓ Class AB

Question Number : 54 Question Id : 2839368974 Question Type : MCQ Option Shuffling : Yes Display Question Number : Yes Is Question Mandatory : No Calculator : None Response Time : N.A Think Time : N.A Minimum Instruction Time : 0

Correct Marks : 1 Wrong Marks : 0

In the negative series clipper, the diode is -----biased when the input becomes -----

Options :

1. ✘ forward, negative

2. ✓ forward, positive

3. ✗ reverse, positive

4. ✗ reverse, negative

Question Number : 55 Question Id : 2839368975 Question Type : MCQ Option Shuffling : Yes Display Question Number : Yes Is Question Mandatory : No Calculator : None Response Time : N.A Think Time : N.A Minimum Instruction Time : 0

Correct Marks : 1 Wrong Marks : 0

The voltage gain of an amplifier without feedback and with negative feedback respectively are 100 and 20, then the percentage of negative feedback (β) would be

Options :

1. ✗ 8%

2. ✗ 5%

3. ✗ 2%

4. ✓ 4%

Question Number : 56 Question Id : 2839368976 Question Type : MCQ Option Shuffling : Yes Display Question Number : Yes Is Question Mandatory : No Calculator : None Response Time : N.A Think Time : N.A Minimum Instruction Time : 0

Correct Marks : 1 Wrong Marks : 0

Which one of the following power amplifiers has the maximum efficiency?

Options :

1. ✘ Class A
2. ✔ Class C
3. ✘ Class AB
4. ✘ Class B

Question Number : 57 Question Id : 2839368977 Question Type : MCQ Option Shuffling : Yes Display Question Number : Yes Is Question Mandatory : No Calculator : None Response Time : N.A Think Time : N.A Minimum Instruction Time : 0

Correct Marks : 1 Wrong Marks : 0

The PIV of Full wave rectifier is

Options :

1. ✘ V_m
2. ✔ $2V_m$
3. ✘ $\frac{V_m}{2}$
4. ✘ $4V_m$

Question Number : 58 Question Id : 2839368978 Question Type : MCQ Option Shuffling : Yes Display Question Number : Yes Is Question Mandatory : No Calculator : None Response Time : N.A Think Time : N.A Minimum Instruction Time : 0

Correct Marks : 1 Wrong Marks : 0

Thermal runaway is not possible in FET because as the temperature of FET increases

Options :

1. ✘ the drain current increases
2. ✘ the transconductance increases
3. ✔ the mobility decreases
4. ✘ the mobility increases

Question Number : 59 Question Id : 2839368979 Question Type : MCQ Option Shuffling : Yes Display Question Number : Yes Is Question Mandatory : No Calculator : None Response Time : N.A Think Time : N.A Minimum Instruction Time : 0

Correct Marks : 1 Wrong Marks : 0

The maximum circuit efficiency for class B operation is

Options :

1. ✘ 25%
2. ✘ 50 %
3. ✔ 78.54%
4. ✘ 84.32%

Question Number : 60 Question Id : 2839368980 Question Type : MCQ Option Shuffling : Yes Display Question Number : Yes Is Question Mandatory : No Calculator : None Response Time : N.A Think Time : N.A Minimum Instruction Time : 0

Correct Marks : 1 Wrong Marks : 0

A negative feedback results all except

Options :

1. ✘ More linear operation
2. ✘ Better stabilizer voltage gain
3. ✘ Improved frequency response
4. ✔ Increased noise

Question Number : 61 Question Id : 2839368981 Question Type : MCQ Option Shuffling : Yes
Display Question Number : Yes Is Question Mandatory : No Calculator : None Response Time
: N.A Think Time : N.A Minimum Instruction Time : 0

Correct Marks : 1 Wrong Marks : 0

Find the complement of the following function: $f = x(\overline{yz} + yz)$

Options :

1. ✔ $\overline{x} + y\overline{z} + \overline{y}z$
2. ✘ $\overline{xy} + \overline{yz}$
3. ✘ $\overline{xz} + y\overline{z} + \overline{y}z$
4. ✘ $\overline{xy} + y\overline{z}$

Question Number : 62 Question Id : 2839368982 Question Type : MCQ Option

Display Question Number : Yes Is Question Mandatory : No Calculator : None Response Time : N.A Think Time : N.A Minimum Instruction Time : 0

Correct Marks : 1 Wrong Marks : 0

Match the following logic family with its significant characteristic:

- | | |
|---------------------|---------------------------|
| a. ECL | i. Low power dissipation |
| b. TTL | ii. Low propagation delay |
| c. CMOS | iii. Noise immunity |
| d. I ² L | iv. High fan-out |

Options :

1. ✘ a – iv, b – iii, c – i, d – ii

2. ✘ a – iii, b – iv, c – ii, d – i

3. ✘ a – i, b – ii, c – iv, d – iii

4. ✔ a – ii, b – i, c – iii, d – iv

Question Number : 63 Question Id : 2839368983 Question Type : MCQ Option Shuffling : Yes Display Question Number : Yes Is Question Mandatory : No Calculator : None Response Time : N.A Think Time : N.A Minimum Instruction Time : 0

Correct Marks : 1 Wrong Marks : 0

The decade counter can also be called as

Options :

1. ✔ divided by 10 counter

2. ✘ mod-16 counter

3. ✘ up and down counter

4. ✘ multiply by 2x5 counter

Question Number : 64 Question Id : 2839368984 Question Type : MCQ Option Shuffling : Yes
Display Question Number : Yes Is Question Mandatory : No Calculator : None Response Time
: N.A Think Time : N.A Minimum Instruction Time : 0

Correct Marks : 1 Wrong Marks : 0

The product of maxterms of the Boolean function $f = xy + \bar{x}z$ is

Options :

1. ✘ $F(x, y, z) = \sum(0, 2, 4, 5)$

2. ✘ $F(x, y, z) = \sum(1, 3, 6, 7)$

3. ✔ $F(x, y, z) = \prod(0, 2, 4, 5)$

4. ✘ $F(x, y, z) = \prod(1, 3, 6, 7)$

Question Number : 65 Question Id : 2839368985 Question Type : MCQ Option Shuffling : Yes
Display Question Number : Yes Is Question Mandatory : No Calculator : None Response Time
: N.A Think Time : N.A Minimum Instruction Time : 0

Correct Marks : 1 Wrong Marks : 0

The advantage of SRAM over DRAM is

Options :

1. ✘ requires less no of transistors

2. ✔ speed

3. ✘ consume less power

4. ✘ density is high

Question Number : 66 Question Id : 2839368986 Question Type : MCQ Option Shuffling : Yes Display Question Number : Yes Is Question Mandatory : No Calculator : None Response Time : N.A Think Time : N.A Minimum Instruction Time : 0

Correct Marks : 1 Wrong Marks : 0

For implementation of Boolean functions with NAND gates, the function be in the form of

Options :

1. ✔ sum-of-products

2. ✘ product-of-sums

3. ✘ arithmetic form

4. ✘ algebraic form

Question Number : 67 Question Id : 2839368987 Question Type : MCQ Option Shuffling : Yes Display Question Number : Yes Is Question Mandatory : No Calculator : None Response Time : N.A Think Time : N.A Minimum Instruction Time : 0

Correct Marks : 1 Wrong Marks : 0

Which of the following is not correct with respect to the procedure for converting a multilevel AND-OR diagram into all NAND diagram?

Options :

1. ✘ Convert all AND gates to NAND gates with AND-invert graphic symbol

2. ✘ Convert all OR gates to NAND gates with invert-OR graphic symbols

For every bubble that is not compensated by another small circle along the same

3. ✘ line, insert an inverter

4. ✔ Convert all OR gates to AND gates

Question Number : 68 Question Id : 2839368988 Question Type : MCQ Option Shuffling : Yes Display Question Number : Yes Is Question Mandatory : No Calculator : None Response Time : N.A Think Time : N.A Minimum Instruction Time : 0

Correct Marks : 1 Wrong Marks : 0

Which of the following gate is most popularly used for Parity checker?

Options :

1. ✘ OR

2. ✔ Ex-OR

3. ✘ AND

4. ✘ NAND

Question Number : 69 Question Id : 2839368989 Question Type : MCQ Option Shuffling : Yes Display Question Number : Yes Is Question Mandatory : No Calculator : None Response Time : N.A Think Time : N.A Minimum Instruction Time : 0

Correct Marks : 1 Wrong Marks : 0

All of the following combinations of gates are used to form a full adder except

Options :

1. ✘ Two half adders, one OR gate
2. ✘ Seven AND gates, two OR gates
3. ✔ Two AND gate, two OR gates, two NOT gates
4. ✘ Two Ex-OR gates, Two AND gates, one OR gate

Question Number : 70 Question Id : 2839368990 Question Type : MCQ Option Shuffling : Yes Display Question Number : Yes Is Question Mandatory : No Calculator : None Response Time : N.A Think Time : N.A Minimum Instruction Time : 0

Correct Marks : 1 Wrong Marks : 0

Which one is not correct with respect to a four-bit magnitude comparator?

Options :

1. ✘ Compare the relative magnitudes of two numbers
2. ✘ Two four-bit numbers are equal if and only if all the bits in two numbers are same.
3. ✘ Comparison starts from most significant position based on that it decide greater or lower.
4. ✔ Comparison starts from least significant position based on that it decide greater or lower.

Question Number : 71 Question Id : 2839368991 Question Type : MCQ Option Shuffling : Yes Display Question Number : Yes Is Question Mandatory : No Calculator : None Response Time : N.A Think Time : N.A Minimum Instruction Time : 0

Correct Marks : 1 Wrong Marks : 0

The number of 512×4 bit ROMs required for 512×8 bit ROM is

Options :

1. ✘ 1

2. ✔ 2

3. ✘ 3

4. ✘ 4

Question Number : 72 Question Id : 2839368992 Question Type : MCQ Option Shuffling : Yes Display Question Number : Yes Is Question Mandatory : No Calculator : None Response Time : N.A Think Time : N.A Minimum Instruction Time : 0

Correct Marks : 1 Wrong Marks : 0

If N logic equations of M variables are given in the sum-of-products canonical form, these equations may be implemented using ROM with

Options :

1. ✘ M -input, N^2 - output

2. ✘ N input, M - output

3. ✘ N^2 -input, M^2 -output

4. ✔ M -input, N -output

Question Number : 73 Question Id : 2839368993 Question Type : MCQ Option Shuffling : Yes Display Question Number : Yes Is Question Mandatory : No Calculator : None Response Time : N.A Think Time : N.A Minimum Instruction Time : 0

Correct Marks : 1 Wrong Marks : 0

When a human being tries to approach an object, his brain acts as ---

Options :

1. ✓ a controller
2. ✗ an error measuring device
3. ✗ an actuator
4. ✗ an amplifier

**Question Number : 74 Question Id : 2839368994 Question Type : MCQ Option Shuffling : Yes
Display Question Number : Yes Is Question Mandatory : No Calculator : None Response Time
: N.A Think Time : N.A Minimum Instruction Time : 0**

Correct Marks : 1 Wrong Marks : 0

A 8086 is designed to operate in maximum mode by applying

Options :

1. ✗ logic 1 to the $MN/M\bar{X}$ input pin, configured as multi-microprocessors
2. ✗ logic 1 to the $MN/M\bar{X}$ input pin, configured as single microprocessors
3. ✓ logic 0 to the $MN/M\bar{X}$ input pin, configured as multi-microprocessors
4. ✗ logic 0 to the $MN/M\bar{X}$ input pin, configured as single microprocessors

**Question Number : 75 Question Id : 2839368995 Question Type : MCQ Option Shuffling : Yes
Display Question Number : Yes Is Question Mandatory : No Calculator : Non**

: N.A Think Time : N.A Minimum Instruction Time : 0

Correct Marks : 1 Wrong Marks : 0

Which one of the following is wrong with reference to source index (SI) register in 8086 microprocessor?

Options :

1. ✘ SI is a 16-bit register
2. ✔ SI used in conjunction with the ES register
3. ✘ SI used in conjunction with the DS register
4. ✘ SI is used for indexed

Question Number : 76 Question Id : 2839368996 Question Type : MCQ Option Shuffling : Yes
Display Question Number : Yes Is Question Mandatory : No Calculator : None Response Time
: N.A Think Time : N.A Minimum Instruction Time : 0

Correct Marks : 1 Wrong Marks : 0

In a closed loop system, the actuating signal is

Options :

1. ✘ equal to feedback signal
2. ✘ same as control signal
3. ✔ the difference between input and output signals
4. ✘ the reference input signal

Question Number : 77 Question Id : 2839368997 Question Type : MCQ Option Shuffling : Yes
Display Question Number : Yes Is Question Mandatory : No Calculator : None Response Time
: N.A Think Time : N.A Minimum Instruction Time : 0

Correct Marks : 1 Wrong Marks : 0

Which of the following is not the effect of feedback in control systems?

Options :

1. ✘ increase or decrease the gain
2. ✘ increases the stability
3. ✘ insensitive to parameter variations
4. ✔ increases the noise effect

Question Number : 78 Question Id : 2839368998 Question Type : MCQ Option Shuffling : Yes
Display Question Number : Yes Is Question Mandatory : No Calculator : None Response Time
: N.A Think Time : N.A Minimum Instruction Time : 0

Correct Marks : 1 Wrong Marks : 0

For the unit step input, the steady state error is given by

Options :

1. ✘ $\frac{1}{k_p}$

2. ✘ $\frac{1}{k_v}$

3. ✘ $\frac{1}{k_a}$

4. ✔

$$\frac{1}{1+k_p}$$

Question Number : 79 Question Id : 2839368999 Question Type : MCQ Option Shuffling : Yes
Display Question Number : Yes Is Question Mandatory : No Calculator : None Response Time
: N.A Think Time : N.A Minimum Instruction Time : 0

Correct Marks : 1 Wrong Marks : 0

If the open loop transfer function is $\frac{K}{s(s+8)}$, the root loci

Options :

1. ✘ begin at ∞ and 0, and terminate at -8
2. ✘ begin at 0 and terminate at -8 and ∞
3. ✘ begin at -8 and terminate at 0 and ∞
4. ✔ begin at 0 and -8 and terminate at ∞

Question Number : 80 Question Id : 2839369000 Question Type : MCQ Option Shuffling : Yes
Display Question Number : Yes Is Question Mandatory : No Calculator : None Response Time
: N.A Think Time : N.A Minimum Instruction Time : 0

Correct Marks : 1 Wrong Marks : 0

The percentage overshoot of second order system is

Options :

1. ✔ $100 e^{\zeta\pi/\sqrt{1-\zeta^2}}$

2. ✘ $100 \frac{\pi}{w_n\sqrt{1-\zeta^2}}$

3. ✘ $\pi W_n \zeta$

4. ✘ $\pi \zeta \sqrt{1 - W_n}$

Question Number : 81 Question Id : 2839369001 Question Type : MCQ Option Shuffling : Yes
Display Question Number : Yes Is Question Mandatory : No Calculator : None Response Time
: N.A Think Time : N.A Minimum Instruction Time : 0

Correct Marks : 1 Wrong Marks : 0

The commonly used test signals in control system are

Options :

1. ✔ Impulse, ramp, step

2. ✘ Square, impulse, ramp

3. ✘ Ramp, square, step

4. ✘ Step, impulse, square

Question Number : 82 Question Id : 2839369002 Question Type : MCQ Option Shuffling : Yes
Display Question Number : Yes Is Question Mandatory : No Calculator : None Response Time
: N.A Think Time : N.A Minimum Instruction Time : 0

Correct Marks : 1 Wrong Marks : 0

Consider the control system function $F(s) = \frac{5}{s(s^2+s+2)}$, then the value of $\lim_{t \rightarrow \infty} f(t)$ is

Options :

1. ✘ 0

2. ✓ $5/2$

3. ✗ $2/5$

4. ✗ ∞

Question Number : 83 Question Id : 2839369003 Question Type : MCQ Option Shuffling : Yes Display Question Number : Yes Is Question Mandatory : No Calculator : None Response Time : N.A Think Time : N.A Minimum Instruction Time : 0

Correct Marks : 1 Wrong Marks : 0

If the number of changes of signs in the elements of the first column of Routh's tabulation equals the number of roots, then the system has

Options :

1. ✗ negative real parts

2. ✓ positive real parts

3. ✗ negative imaginary parts

4. ✗ positive imaginary parts

Question Number : 84 Question Id : 2839369004 Question Type : MCQ Option Shuffling : Yes Display Question Number : Yes Is Question Mandatory : No Calculator : None Response Time : N.A Think Time : N.A Minimum Instruction Time : 0

Correct Marks : 1 Wrong Marks : 0

Find the input-output function for system shown below

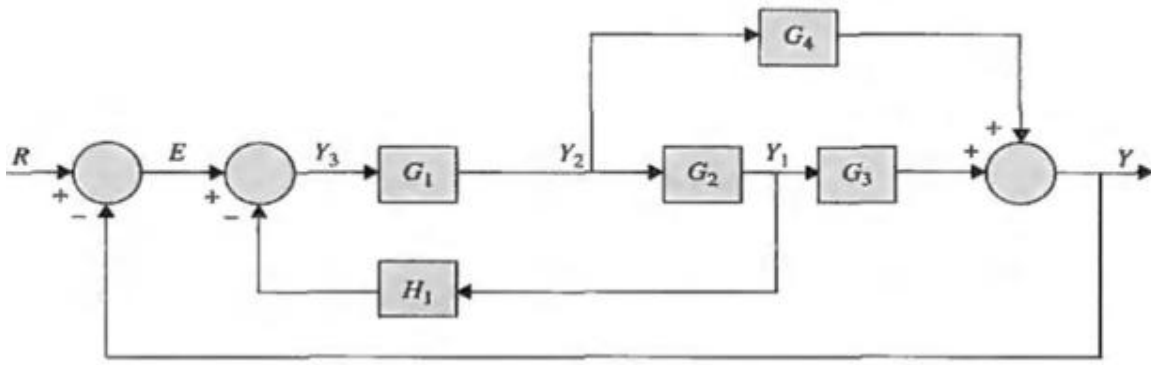

Options :

1. ✘ $\frac{Y(s)}{E(s)} = \frac{G_1 G_2 G_3 + G_4}{1 + G_2 G_3 H_1 + G_1 G_2 G_3}$

2. ✘ $\frac{E(s)}{Y(s)} = \frac{G_1 G_2 G_3 + G_4}{1 + G_2 G_3 H_1 + G_1 G_2 G_3}$

3. ✘ $\frac{E(s)}{Y(s)} = \frac{G_1 G_2 G_3 + G_1 G_4}{1 + G_2 G_3 H_1 + G_1 G_2 G_3 + G_1 G_4}$

4. ✔ $\frac{Y(s)}{E(s)} = \frac{G_1 G_2 G_3 + G_1 G_4}{1 + G_2 G_3 H_1 + G_1 G_2 G_3 + G_1 G_4}$

Question Number : 85 Question Id : 2839369005 Question Type : MCQ Option Shuffling : Yes
 Display Question Number : Yes Is Question Mandatory : No Calculator : None Response Time : N.A Think Time : N.A Minimum Instruction Time : 0

Correct Marks : 1 Wrong Marks : 0

Two parts of a signal flow graph are non-touching, if they do not share a common

Options :

1. ✔ node

2. ✘ path

3. ✘ loop gain

4. ✘ feed back

Question Number : 86 Question Id : 2839369006 Question Type : MCQ Option Shuffling : Yes Display Question Number : Yes Is Question Mandatory : No Calculator : None Response Time : N.A Think Time : N.A Minimum Instruction Time : 0

Correct Marks : 1 Wrong Marks : 0

The _____ is defined as the time required for the step response to reach 50% of its final value

Options :

1. ✘ fall time

2. ✘ rise time

3. ✔ delay time

4. ✘ settling time

Question Number : 87 Question Id : 2839369007 Question Type : MCQ Option Shuffling : Yes Display Question Number : Yes Is Question Mandatory : No Calculator : None Response Time : N.A Think Time : N.A Minimum Instruction Time : 0

Correct Marks : 1 Wrong Marks : 0

The steady-state error of type 1 system with ramp input is

Options :

1. ✘ zero

2. ✓ constant

3. ✘ undefined

4. ✘ infinity

Question Number : 88 Question Id : 2839369008 Question Type : MCQ Option Shuffling : Yes Display Question Number : Yes Is Question Mandatory : No Calculator : None Response Time : N.A Think Time : N.A Minimum Instruction Time : 0

Correct Marks : 1 Wrong Marks : 0

The imaginary axis corresponds to

Options :

1. ✘ zero damping, system is stable

2. ✘ negative damping, system is unstable

3. ✘ positive damping, system is stable

4. ✓ zero damping, system is marginally stable or marginally unstable

Question Number : 89 Question Id : 2839369009 Question Type : MCQ Option Shuffling : Yes Display Question Number : Yes Is Question Mandatory : No Calculator : None Response Time : N.A Think Time : N.A Minimum Instruction Time : 0

Correct Marks : 1 Wrong Marks : 0

The number of branches of the Root Loci of the following equation with K varies from $-\infty$ to ∞ is

$$s(s + 2)(s + 3) + K(s + 1) = 0$$

Options :

1. ✘ 0

2. ✘ 3

3. ✔ 4

4. ✘ ∞

**Question Number : 90 Question Id : 2839369010 Question Type : MCQ Option Shuffling : Yes
Display Question Number : Yes Is Question Mandatory : No Calculator : None Response Time
: N.A Think Time : N.A Minimum Instruction Time : 0**

Correct Marks : 1 Wrong Marks : 0

If the $(-1, j0)$ point is enclosed by the Nyquist plot, the system is

Options :

1. ✔ unstable

2. ✘ stable

3. ✘ marginally stable

4. ✘ conditionally stable

**Question Number : 91 Question Id : 2839369011 Question Type : MCQ Option Shuffling : Yes
Display Question Number : Yes Is Question Mandatory : No Calculator : None Response Time
: N.A Think Time : N.A Minimum Instruction Time : 0**

Correct Marks : 1 Wrong Marks : 0

The poisson random variable has a density given by

Options :

1. ✘ $\frac{1}{b} e^{-(x-a)/b}$

2. ✘ $1 - e^{-(x-a)/b}$

3. ✘ $e^b \sum_{k=0}^{\infty} \frac{b^k}{k!} u(x - k)$

4. ✔ $e^b \sum_{k=0}^{\infty} \frac{b^k}{k!} \delta(x - k)$

Question Number : 92 Question Id : 2839369012 Question Type : MCQ Option Shuffling : Yes
Display Question Number : Yes Is Question Mandatory : No Calculator : None Response Time
: N.A Think Time : N.A Minimum Instruction Time : 0

Correct Marks : 1 Wrong Marks : 0

The stages in a three-stage amplifier have effective input noise temperatures $T_{e1} = 1350K$,
 $T_{e2} = 1700K$, $T_{e3} = 2600K$ respectively. The respective available power gains are
 $G_1 = 16$, $G_2 = 10$, $G_3 = 6$ then the effective input noise temperature of the overall
amplifier is

Options :

1. ✘ 766.59 K

2. ✔ 1472.5 K

3. ✘ 4578 K

4. ✘ 5650 K

Question Number : 93 Question Id : 2839369013 Question Type : MCQ Option Shuffling : Yes
Display Question Number : Yes Is Question Mandatory : No Calculator : None Response Time
: N.A Think Time : N.A Minimum Instruction Time : 0

Correct Marks : 1 Wrong Marks : 0

Which of the following statement is true?

Options :

1. ✘ Coherent systems does not need frequency synchronization
2. ✘ Coherent systems does not need phase synchronization
3. ✘ Non-Coherent systems does not need frequency synchronization
4. ✔ Non-Coherent systems does not need phase synchronization

Question Number : 94 Question Id : 2839369014 Question Type : MCQ Option Shuffling : Yes
Display Question Number : Yes Is Question Mandatory : No Calculator : None Response Time
: N.A Think Time : N.A Minimum Instruction Time : 0

Correct Marks : 1 Wrong Marks : 0

The value of the autocorrelation function of a power signal at the origin is

Options :

1. ✘ 0
2. ✘ τ
3. ✘ $-\tau$
4. ✔ average power of the signal

Question Number : 95 Question Id : 2839369015 Question Type : MCQ Option Shuffling : Yes
Display Question Number : Yes Is Question Mandatory : No Calculator : None Response Time
: N.A Think Time : N.A Minimum Instruction Time : 0

Correct Marks : 1 Wrong Marks : 0

The aliased components are removed by filters with

Options :

1. ✘ large transition bandwidth
2. ✘ sampling rate less than signal frequency
3. ✔ sharper cut-off frequency
4. ✘ low out-off band attenuation

Question Number : 96 Question Id : 2839369016 Question Type : MCQ Option Shuffling : Yes
Display Question Number : Yes Is Question Mandatory : No Calculator : None Response Time
: N.A Think Time : N.A Minimum Instruction Time : 0

Correct Marks : 1 Wrong Marks : 0

The quantization noise ----- is employed in the quantization process

Options :

1. ✘ proportional to the number of levels
2. ✔ inversely proportional to the number of levels
3. ✘ proportional to the signal frequency

4. ✘ inversely proportional to the signal frequency

Question Number : 97 Question Id : 2839369017 Question Type : MCQ Option Shuffling : Yes
Display Question Number : Yes Is Question Mandatory : No Calculator : None Response Time
: N.A Think Time : N.A Minimum Instruction Time : 0

Correct Marks : 1 Wrong Marks : 0

The effect of the jitter is equivalent to ----- of the baseband signal

Options :

1. ✘ AM

2. ✘ DSB

3. ✘ SSB

4. ✔ FM

Question Number : 98 Question Id : 2839369018 Question Type : MCQ Option Shuffling : Yes
Display Question Number : Yes Is Question Mandatory : No Calculator : None Response Time
: N.A Think Time : N.A Minimum Instruction Time : 0

Correct Marks : 1 Wrong Marks : 0

When the channel bandwidth is close to the signal bandwidth, the spreading will exceed
a symbol duration and cause signal pulse to overlap, then it is called

Options :

1. ✔ Inter Symbol Interference

2. ✘ Overlap- add

3. ✘ Overlap-save

4. ✘ Noise over

Question Number : 99 Question Id : 2839369019 Question Type : MCQ Option Shuffling : Yes Display Question Number : Yes Is Question Mandatory : No Calculator : None Response Time : N.A Think Time : N.A Minimum Instruction Time : 0

Correct Marks : 1 Wrong Marks : 0

When pulse modulation is applied to a binary symbol, the resulting binary waveform is called

Options :

1. ✘ PAM

2. ✘ M-ary PAM

3. ✔ PCM

4. ✘ PM

Question Number : 100 Question Id : 2839369020 Question Type : MCQ Option Shuffling : Yes Display Question Number : Yes Is Question Mandatory : No Calculator : None Response Time : N.A Think Time : N.A Minimum Instruction Time : 0

Correct Marks : 1 Wrong Marks : 0

Which one of the following types of noise, is important at high frequency?

Options :

1. ✘ Shot noise

2. ✘ Random noise

3. ✘ Impulse noise

4. ✔ Transit-time noise

Question Number : 101 Question Id : 2839369021 Question Type : MCQ Option Shuffling : Yes Display Question Number : Yes Is Question Mandatory : No Calculator : None Response Time : N.A Think Time : N.A Minimum Instruction Time : 0

Correct Marks : 1 Wrong Marks : 0

The matched filter differs from correlator in such a way that

Options :

1. ✘ it computes an output at the peak value of input

2. ✘ it computes an output once per symbol time

3. ✔ the output will be a time series

4. ✘ the output sequence equated to single correlator operating at starting point of input

Question Number : 102 Question Id : 2839369022 Question Type : MCQ Option Shuffling : Yes Display Question Number : Yes Is Question Mandatory : No Calculator : None Response Time : N.A Think Time : N.A Minimum Instruction Time : 0

Correct Marks : 1 Wrong Marks : 0

The following receiver is most preferable for non-coherent detection of FSK

Options :

1. ✘ Envelop detector

2. ✓ Quadrature receiver

3. ✗ Delay time receiver

4. ✗ Balanced modulator

Question Number : 103 Question Id : 2839369023 Question Type : MCQ Option Shuffling : Yes Display Question Number : Yes Is Question Mandatory : No Calculator : None Response Time : N.A Think Time : N.A Minimum Instruction Time : 0

Correct Marks : 1 Wrong Marks : 0

The number of errors that correct by the code with minimum hamming distance 5 is

Options :

1. ✗ 1

2. ✓ 2

3. ✗ 3

4. ✗ 4

Question Number : 104 Question Id : 2839369024 Question Type : MCQ Option Shuffling : Yes Display Question Number : Yes Is Question Mandatory : No Calculator : None Response Time : N.A Think Time : N.A Minimum Instruction Time : 0

Correct Marks : 1 Wrong Marks : 0

Which of the following shuffles the code symbols over a span of several constraint lengths?

Options :

1. ✘ encoder
2. ✘ decoder
3. ✔ interleaver
4. ✘ shifter

Question Number : 105 Question Id : 2839369025 Question Type : MCQ Option Shuffling : Yes Display Question Number : Yes Is Question Mandatory : No Calculator : None Response Time : N.A Think Time : N.A Minimum Instruction Time : 0

Correct Marks : 1 Wrong Marks : 0

The synchronization in receivers is obtained by using

Options :

1. ✘ suppressed carrier loop
2. ✘ local oscillator
3. ✘ RF tuner
4. ✔ PLL

Question Number : 106 Question Id : 2839369026 Question Type : MCQ Option Shuffling : Yes Display Question Number : Yes Is Question Mandatory : No Calculator : None Response Time : N.A Think Time : N.A Minimum Instruction Time : 0

Correct Marks : 1 Wrong Marks : 0

In multiple access scheme

Options :

1. ✘ communication resources sharing are fixed
2. ✘ resource allocation is assigned a priori
3. ✔ remote sharing of resources
4. ✘ sharing is usually process that takes place within the confines of a local site

Question Number : 107 Question Id : 2839369027 Question Type : MCQ Option Shuffling : Yes
Display Question Number : Yes Is Question Mandatory : No Calculator : None Response Time : N.A Think Time : N.A Minimum Instruction Time : 0

Correct Marks : 1 Wrong Marks : 0

A TDMA of the M sources bursts and transmission at R bit/s, is _____ times faster than the equivalent FDMA user for $(1/M)^{\text{th}}$ the time.

Options :

1. ✘ R
2. ✔ M
3. ✘ R/M
4. ✘ M/R

Question Number : 108 Question Id : 2839369028 Question Type : MCQ Option Shuffling : Yes
Display Question Number : Yes Is Question Mandatory : No Calculator : Non

: N.A Think Time : N.A Minimum Instruction Time : 0

Correct Marks : 1 Wrong Marks : 0

The maximum entropy for a source of 4 symbols achieve with probabilities of

Options :

1. ✘ 0.4, 0.2, 0.3, 0.1

2. ✘ 0.2, 0.2, 0.2, 0.4

3. ✘ 0.3, 0.3, 0.2, 0.2

4. ✔ equiprobable

Question Number : 109 Question Id : 2839369029 Question Type : MCQ Option Shuffling : Yes

Display Question Number : Yes Is Question Mandatory : No Calculator : None Response Time

: N.A Think Time : N.A Minimum Instruction Time : 0

Correct Marks : 1 Wrong Marks : 0

Calculate the percentage power saving when the carrier and one of the sidebands are suppressed in an AM wave modulated to a depth of 100 %

Options :

1. ✘ 94.4%

2. ✔ 83.3%

3. ✘ 75%

4. ✘ 50%

Question Number : 110 Question Id : 2839369030 Question Type : MCQ Option Shuffling : Yes
Display Question Number : Yes Is Question Mandatory : No Calculator : None Response Time
: N.A Think Time : N.A Minimum Instruction Time : 0

Correct Marks : 1 Wrong Marks : 0

All are the advantages of having an RF amplifier in receiver except

Options :

1. ✓ poor sensitivity
2. ✗ better selectivity
3. ✗ improved image-frequency rejection
4. ✗ better coupling of the receiver to the antenna

Question Number : 111 Question Id : 2839369031 Question Type : MCQ Option Shuffling : Yes
Display Question Number : Yes Is Question Mandatory : No Calculator : None Response Time
: N.A Think Time : N.A Minimum Instruction Time : 0

Correct Marks : 1 Wrong Marks : 0

Maxwell's equations are general for the media that can be

Options :

1. ✓ nonhomogeneous, nonlinear, nonisotropic
2. ✗ homogeneous, linear, isotropic
3. ✗ non homogeneous, nonlinear, isotropic
4. ✗ homogeneous, linear, nonisotropic

Question Number : 112 Question Id : 2839369032 Question Type : MCQ Option Shuffling : Yes
Display Question Number : Yes Is Question Mandatory : No Calculator : None Response Time
: N.A Think Time : N.A Minimum Instruction Time : 0

Correct Marks : 1 Wrong Marks : 0

The law of conservation of charge, in its general form, takes into account both free and
bound charges is

Options :

1. ✘ $\nabla \times E = -\frac{\partial B}{\partial t}$

2. ✘ $\nabla \cdot B = 0$

3. ✘ $\nabla \cdot E = \frac{\rho}{\epsilon_0}$

4. ✔ $\nabla \cdot J = -\frac{\partial \rho}{\partial t}$

Question Number : 113 Question Id : 2839369033 Question Type : MCQ Option Shuffling : Yes
Display Question Number : Yes Is Question Mandatory : No Calculator : None Response Time
: N.A Think Time : N.A Minimum Instruction Time : 0

Correct Marks : 1 Wrong Marks : 0

The characteristic impedance of the vacuum is

Options :

1. ✘ 120Ω

2. ✘ 275Ω

3. ✔ 377Ω

4. ✘ ∞

Question Number : 114 Question Id : 2839369034 Question Type : MCQ Option Shuffling : Yes Display Question Number : Yes Is Question Mandatory : No Calculator : None Response Time : N.A Think Time : N.A Minimum Instruction Time : 0

Correct Marks : 1 Wrong Marks : 0

Which theorem states that there is conservation of energy in electromagnetic fields?

Options :

1. ✘ Lorentz's Reciprocity theorem

2. ✔ Poyting theorem

3. ✘ Faraday's law

4. ✘ Gauss's law

Question Number : 115 Question Id : 2839369035 Question Type : MCQ Option Shuffling : Yes Display Question Number : Yes Is Question Mandatory : No Calculator : None Response Time : N.A Think Time : N.A Minimum Instruction Time : 0

Correct Marks : 1 Wrong Marks : 0

Which of the following statement is not true?

Options :

1. ✘ The electric energy density larger than magnetic energy density in conductors

2. ✘ The electric energy density larger than magnetic energy density in nonconductors

3. ✘ The electric energy density equal to magnetic energy density in conductors

4. ✔ The electric energy density equal to magnetic energy density in nonconductors

Question Number : 116 Question Id : 2839369036 Question Type : MCQ Option Shuffling : Yes Display Question Number : Yes Is Question Mandatory : No Calculator : None Response Time : N.A Think Time : N.A Minimum Instruction Time : 0

Correct Marks : 1 Wrong Marks : 0

The ideal value of radiation resistance of half-wave dipole is

Options :

1. ✘ 50Ω

2. ✔ 73.08Ω

3. ✘ 84.32Ω

4. ✘ 95.67Ω

Question Number : 117 Question Id : 2839369037 Question Type : MCQ Option Shuffling : Yes Display Question Number : Yes Is Question Mandatory : No Calculator : None Response Time : N.A Think Time : N.A Minimum Instruction Time : 0

Correct Marks : 1 Wrong Marks : 0

If an incident wave of frequency 1 MHz, then the skin depth for a sea water ($\sigma = 4S/m$) is

Options :

1. ✘ 10 cm

2. ✔ 25cm

3. ✘ 10km

4. ✘ 40 km

Question Number : 118 Question Id : 2839369038 Question Type : MCQ Option Shuffling : Yes Display Question Number : Yes Is Question Mandatory : No Calculator : None Response Time : N.A Think Time : N.A Minimum Instruction Time : 0

Correct Marks : 1 Wrong Marks : 0

The reflection coefficient of medium 1 and 2 with intrinsic impedances of 100Ω and 300Ω respectively and incident electric field intensity of 100 V/m is

Options :

1. ✔ 0.5

2. ✘ 2

3. ✘ 50

4. ✘ 200

Question Number : 119 Question Id : 2839369039 Question Type : MCQ Option Shuffling : Yes Display Question Number : Yes Is Question Mandatory : No Calculator : None Response Time : N.A Think Time : N.A Minimum Instruction Time : 0

Correct Marks : 1 Wrong Marks : 0

A lossless transmission line is 80 cm long and operates at a frequency of 500 MHz with $L=0.25\ \mu\text{H/m}$ and $C=100\text{ pF/m}$, then the characteristic impedance is

Options :

1.

✓ 50Ω

2. ✗ 25Ω

3. ✗ 12Ω

4. ✗ 4Ω

Question Number : 120 Question Id : 2839369040 Question Type : MCQ Option Shuffling : Yes
Display Question Number : Yes Is Question Mandatory : No Calculator : None Response Time
: N.A Think Time : N.A Minimum Instruction Time : 0

Correct Marks : 1 Wrong Marks : 0

Smith chart is not used to calculate

Options :

1. ✗ impedance

2. ✗ admittance

3. ✗ VSWR

4. ✓ intrinsic impedance