



Notations :

- 1.Options shown in **green** color and with  icon are correct.
- 2.Options shown in **red** color and with  icon are incorrect.

NEST 2018

General

Question Number : 1

The number of times the minute and hour hands of a clock overlap in 24 hours is

Options :

22

23

24

25

Question Number : 2

Colostrum, the first milk produced by mother during and soon after childbirth, provides the infant with

Options :

Passive immunity

Active immunity

Auto immunity

Innate immunity

Question Number : 3

A list of scientific events is given below:

(i) discovery of electrons in cathode rays, (ii) discovery of x-rays, (iii) discovery of radioactivity, (iv) observation of fluorescence.

The correct chronological order (earliest to latest) is

Options :

✓ (iv), (ii), (iii), (i)

✗ (i), (ii), (iii), (iv)

✗ (ii), (iv), (i), (iii)

✗ (iii), (ii), (iv), (i)

Question Number : 4

Modern automobiles are equipped with *catalytic converters* at the exhaust. The exhaust emits carbon monoxide, nitrogen oxides and uncombusted hydrocarbons. The catalytic converter converts these harmful substances into

Options :

✓ Carbon dioxide, Nitrogen, Water

✗ Carbon, Nitrogen, Carbon dioxide

✗ Carbon, Ammonia, Carbon dioxide

✗ Carbon, Nitrous oxide, Alkanes

Question Number : 5

In firecrackers, one of the methods to produce colours is to use metal salts. As the crackers burn, different metal ions get heated and produce different colours. To produce yellow colour using metal salts, one should use an appropriate combination of

Options :

✓ Sr + Ba

✗ Sr + Cu

✗ Ba + Cu

✗ Ba + Mg

Questions : No

Question Numbers : (6 to 8)

Some chemical companies generate carbon dioxide through combustion processes and release it into the atmosphere. Carbon dioxide is a greenhouse gas. To limit the pollution due to this gas, the pollution controlling agency gives the companies stipulated allowances, called *carbon credits*, that permits a company to emit an allowed amount of carbon dioxide, expressed as *carbon*, into the atmosphere. If a company exceeds the given allowance, it must buy a permit from other company that has extra carbon credits, to meet the shortfall. This kind of buying and selling of carbon is called *carbon trading*.

In 2015, a company was fined by the Government's Environment Agency for breaches of the prescribed carbon permissions. The company was fined for failing to obtain allowances for almost 2000 tonnes of carbon. According to the Agency, the company produced 4500 tonnes of carbon. The Agency further stated that the company had not submitted the required permissions for the excess emissions within the deadline. The company said in their defense that they had not been discharging excess greenhouse gases into the atmosphere, and in fact the emissions have reduced.

Sub questions

Question Number : 6

Carbon trading involves

Options :

buying and selling of permissions of quantities of carbon allowed to be emitted. ✓

buying and selling of carbon dioxide generated by the companies. ✗

buying and selling of solid carbon generated by the companies. ✗

exchanging the profit gained by releasing carbon dioxide.

Question Number : 7

The company was fined for

Options :

generating 2000 tonnes of carbon dioxide in excess of the allowance.

generating 2500 tonnes of carbon dioxide in excess of the allowance.

generating 2000 tonnes of carbon dioxide.

generating 6500 tonnes of carbon dioxide.

Question Number : 8

As per the Agency, the company should have

Options :

procured an allowance for 4500 tonnes of carbon.

reduced carbon dioxide emission by 2500 tonnes.

submitted the permissions within a month from the deadline.

produced gases other than carbon dioxide.

Questions : No

Question Numbers : (9 to 10)

Like the *square numbers*, one can define *triangular numbers*, *pentagonal numbers* and so on, based on placement of the dots to form shapes of regular polygons. A few examples are shown below.

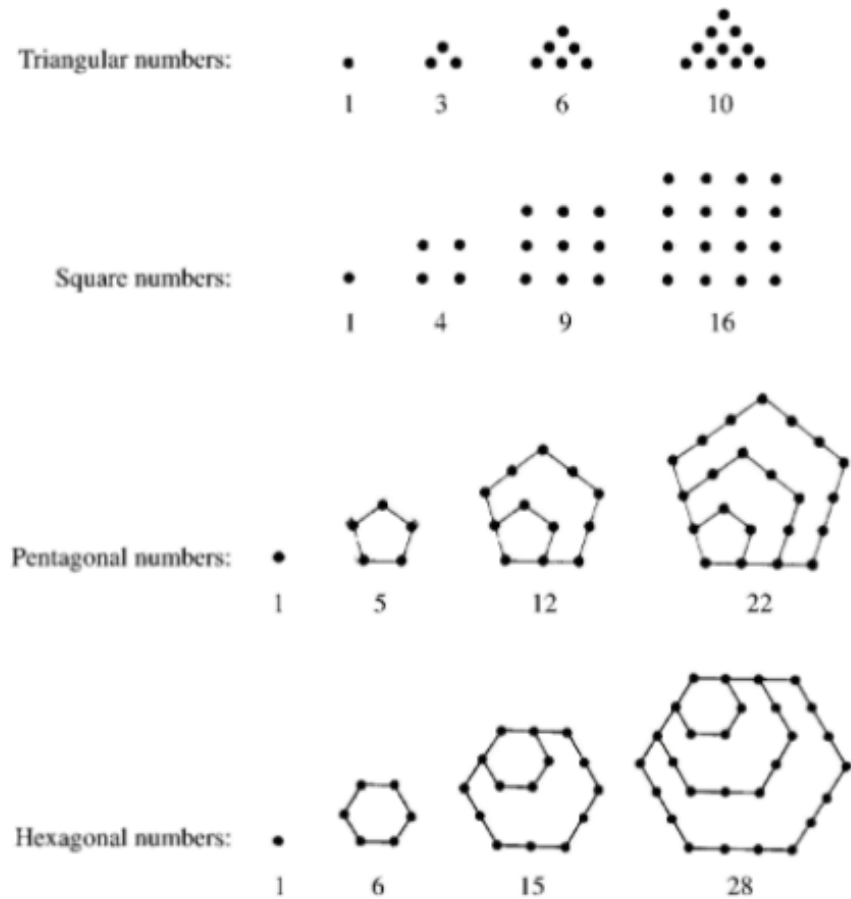

Sub questions

Question Number : 9

According to the illustration above, the fifth hexagonal number is

Options :

✓ 45

✗ 46

✗ 47

✗ 48

Question Number : 10

Among the following, the INCORRECT statement is

Options :

✓ The difference between the fourth pentagonal number and the fourth square number is the fourth triangular number.

✗ Any hexagonal number (except the first) can be expressed as the sum of some triangular number and some pentagonal number.

✗ Any square number (except the first) can be expressed as the sum of two consecutive triangular numbers.

✗ Sum of the fifth pentagonal number and the fifth triangular number is twice the fifth square number.

Biology

Question Number : 11

The combination of numbered terms that correctly completes all the following statements is

- i. Transport through the phloem is 1 while transport through the xylem is 2.
- ii. Loading of sugars into the phloem is 3 at the source.
- iii. Movement of water out of the phloem at the sink is 4

Options :

1 - bidirectional, 2 - unidirectional, 3 - by active transport, 4 - by osmosis

1 - by osmosis, 2 - by turgor pressure, 3 - by passive transport, 4 - bidirectional

1 - unidirectional, 2 - bidirectional, 3 - by diffusion, 4 - unidirectional

1 - by diffusion, 2 - unidirectional, 3 - bidirectional, 4 - by osmosis

Question Number : 12

In the ABC model of floral organ determination in *Arabidopsis*, the expression of class A genes alone determines development of sepals, expression of class A genes along with class B genes determines petal formation, expression of class B genes along with class C genes determines formation of stamens and expression of class C genes alone determines carpel formation. Loss of class B gene function would result in flowers with whorls in the following order (from outer whorl to inner whorl)

Options :

sepal, sepal, carpel, carpel

sepal, petal, petal, sepal

carpel, stamen, stamen, carpel

sepal, petal, stamen, carpel

Question Number : 13

A cross between two plants with genotypes, PpQq and PpQq was carried out where P and Q are dominant over p and q, respectively. Of the total progeny obtained, the proportion of the offspring that would only express one of the two dominant alleles is

Options :

15/16

3/16

3/8

9/16

Question Number : 14

Few statements about water reabsorption in kidney are given below:

- i. decreased production of anti-diuretic hormone.
- ii. increased osmolality of plasma.
- iii. decreased permeability of kidney tubule epithelium to water.
- iv. increased reabsorption of water.

The consequence(s) of dehydration in an otherwise healthy human would be

Options :

(i) and (iii) only

(iv) only

(ii) and (iv) only

(i), (ii) and (iv) only

Question Number : 15

A deer with energy reserves of 150 kJ spends 54 kJ in respiration, while 84 kJ is excreted as feces and urine. Based on this information, the efficiency of energy transfer from the deer eaten by a lion, will be

Options :

✓ 8%

✗ 10%

✗ 92%

✗ 20%

Question Number : 16

Data on the resting metabolic rates (MR) of a few adult animals are tabulated below.

Animal	Resting MR (ml O ₂ g ⁻¹ h ⁻¹)	Type of animal
M	0.33	Warm blooded
N	0.03	Cold blooded
O	2.30	Warm blooded
Q	0.04	Warm blooded

The correct combination of animals in the order from M – Q is

Note: For this question, discrepancy is found in question/answer. So, this question is ignored for all candidates.

Options :

Mouse, Fruitfly, Turtle, Dog, Whale

Dog, Turtle, Fruitfly, Mouse, Whale

Mouse, Turtle, Fruitfly, Whale, Dog

Dog, Whale, Fruitfly, Turtle, Mouse

Question Number : 17

A person had therapeutic surgery, which removed part of his stomach. Later, he started suffering from pernicious anemia. Biochemical tests showed that he had vitamin B12 deficiency. The most plausible cause for this deficiency is

Options :

✓ Loss of parietal or oxyntic cells.

- ✘ Lack of vitamin B12 producing intestinal cells.
- ✘ Loss of peptic or chief cells.
- ✘ Loss of goblet cells.

Question Number : 18

The number of chromatids present in a human cell in the G2 phase, prophase, post-cytokinesis and G1 phase, respectively are

Options :

- ✔ 92-92-46-46
- ✘ 46-92-92-46
- ✘ 92-46-46-92
- ✘ 46-46-23-23

Question Number : 19

The property that is **NOT** common to mitochondria and chloroplasts is

Options :

- ✘ the machinery to generate ATP
- ✘ the presence of double membrane
- ✔ the presence of same set of electron acceptors
- ✘ the non-Mendelian pattern of inheritance

Question Number : 20

The sequence of a double stranded DNA, which produces a pentapeptide is given below:

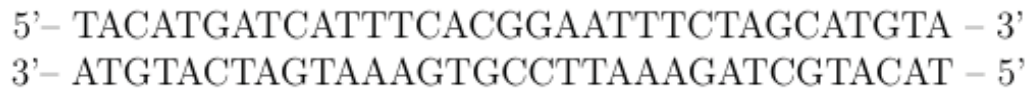

The correct mRNA sequence corresponding to the pentapeptide is

Options :

- ✓ 3'-AGU GCC UUA AAG AUC GUA-5'
- ✗ 5'-AGU GCC UUA AAG AUC GUA-3'
- ✗ 5'-AUG AUC AUU UCA CGG AAU-3'
- ✗ 3'-AUG UAC UAG UAA AGU GCC-5'

Question Number : 21

The Russian scientist G. F. Gause carried out experiments on three species of *Paramecium* by growing each species separately in identical culture conditions (Experiments 1, 2 and 3) as well as in combination of two species grown together (Experiments 4 and 5). The results of the experiments are shown in the below graphs.

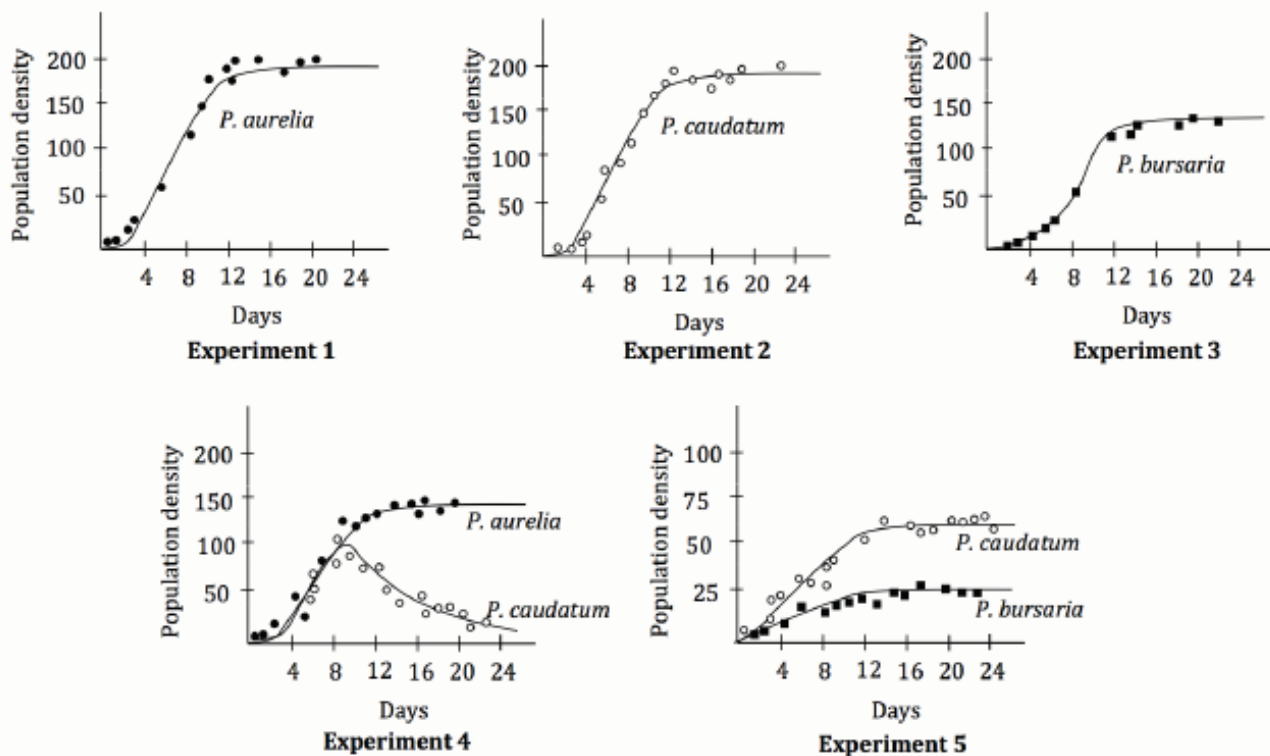

Based on the graphs, the correct statement(s) is/are

Options :

✘ The carrying capacity of the culture media is identical for all the three species.

✔ *P. caudatum* and *P. aurelia* share the same realized niche.

✔ When grown together, *P. aurelia* utilizes resources more efficiently than *P. caudatum*.

✘ Competition has a negative effect on the growth of *P. bursaria* and a positive effect on the growth of *P. caudatum*.

Question Number : 22

In biological systems, proteins (repressors and activators) control gene expression. Repressors bind to promoters and inhibit gene expression. Some promoters require activators for gene expression. These constitute a genetic circuit and are analogous to logic gates in digital electronics. A schematic diagram of a genetic circuit in a cell is shown below. Binding of IPTG to LacI activates transcription from P_{lac} . Binding of arabinose (Ara) to AraC activates transcription from P_{ara} .

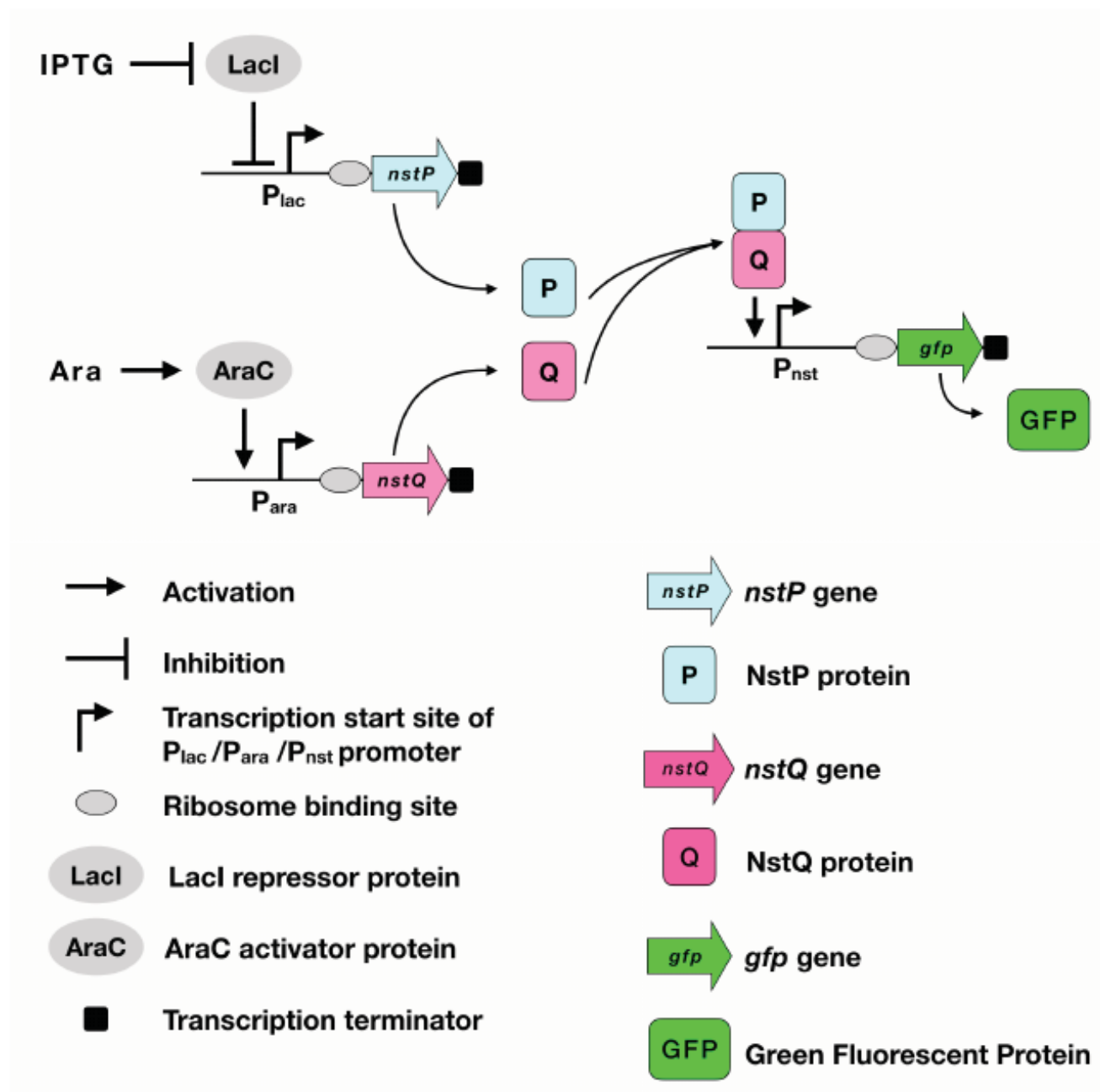

The correct statement(s) regarding the given genetic circuit is/are

Options :

- ✓ GFP is made in the presence of IPTG and arabinose.
- ✗ GFP is made if either IPTG or Arabinose is present.
- ✓ This is an example of a genetic 'AND' gate.

✘ This is an example of a genetic 'NOR' gate.

Question Number : 23

The graph given below shows the Michaelis-Menten kinetics for two reactions (R1 and R2; represented as solid and dotted lines, respectively). Enzymes E1 and E2 have V_{\max} values, $V_{\max 1}$ and $V_{\max 2}$, respectively. The respective K_M values for E1 and E2 are K_{M1} and K_{M2} . ($K_{M1} = K_{M2}$).

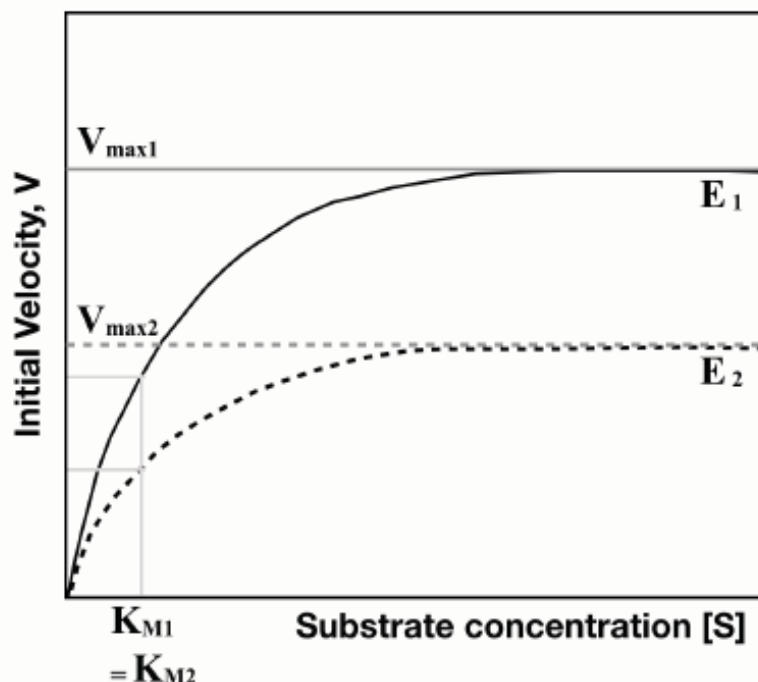

The correct statement(s) for reactions R1 and R2 is/are

Options :

✘ E₁ and E₂ can never be the same enzyme.

E₁ and E₂ may be the same enzyme, acting on two different substrates
✘ with different affinities.

E₁ and E₂ may represent two different concentrations of the same enzyme, acting on the same substrate.
✔

E₁ and E₂ may be two different enzymes, with the same affinity for the substrate.
✔

Question Number : 24

Khorana performed experiments to decipher the codons that code for a particular amino acid. The results of these experiments using synthetic mRNAs and the corresponding polypeptide repeats that were generated are given in the table below.

Synthetic mRNAs	Polypeptide(s) synthesized
$(CAA)_n$	$(Thr-Thr)_n$ and $(Asn-Asn)_n$ and $(Gln-Gln)_n$
$(UUC)_n$	$(Ser-Ser)_n$ and $(Leu-Leu)_n$ and $(Phe-Phe)_n$
$(UAC)_n$	$(Thr-Thr)_n$ and $(Leu-Leu)_n$ and $(Tyr-Tyr)_n$
$(UUAC)_n$	$(Leu-Leu-Thr-Tyr)_n$

Based on the results, the correct combination(s) of codons and amino acids is/are

Options :

✘ ACU – Leu; UUA – Thr; ACU – Tyr

✔ CUU – Leu; ACA – Thr; UAC – Tyr

✘ UAC – Leu; CUU – Thr; ACU – Tyr

✔ UUA – Leu; ACU – Thr; UAC – Tyr

Question Number : 25

The condition(s) that allow(s) a population to exist in genetic equilibrium is/are:

Options :

✘ Mutations leading to an increase in fitness should occur.

✔ Migration of individuals should be prevented so that alleles found in one area may not get removed from or introduced into other areas.

✔ All individuals in a population should have an equal chance of survival.

✔ Random changes in allelic combinations occurring during meiosis should get absorbed without any scope for their preferential multiplication.

Question Number : 26

In H_3PO_2 and H_3PO_3 , the numbers of P–H bonds are, respectively,

Options :

✘ 1, 1

✘ 1, 2

✔ 2, 1

✘ 3, 2

Question Number : 27

Oxidation of NaBH_4 with iodine results in evolution of a colorless gas, X, along with formation of NaI and hydrogen gas. Three moles of X react with six moles of NH_3 to give an intermediate which upon heating results in Y accompanied by evolution of hydrogen gas. Compounds X and Y, respectively, are

Options :

✘ BH_3 , $\text{H}_3\text{B} \bullet \text{NH}_3$

✘ B_2H_6 , $\text{H}_3\text{B} \bullet \text{NH}_3$

✔ B_2H_6 , $\text{B}_3\text{N}_3\text{H}_6$

✘ BH_3 , $[\text{BH}_2(\text{NH}_3)_2]^+ [\text{BH}_4]^-$

Question Number : 28

The correct order of acidity is

Options :

- ✓ $C_2H_2 < H_2O_2 < HCN < HSCN$
- ✗ $C_2H_2 < H_2O_2 < HSCN < HCN$
- ✗ $H_2O_2 < C_2H_2 < HSCN < HCN$
- ✗ $H_2O_2 < C_2H_2 < HCN < HSCN$

Question Number : 29

In electrolytic refining of blister copper

Options :

- ✗ acidified $[Cu(NH_3)_4]^{2+}$ can be used as electrolyte.
 - pure Cu deposits at anode and metal impurities Ag and Au go into the solution as ions.
- ✓ pure Cu deposits at cathode while Ag and Au remain at anode.
- ✗ Cu^{2+} reduces to Cu at anode and Cu oxidizes to Cu^{2+} at cathode.

Question Number : 30

Consider the chemical reaction $P \rightarrow Q$, being carried out in two different vessels X and Y with 1 litre solution of P in each of them. The reactions are started with 1 mole of P in X and 2 moles of P in Y. Further P is added continuously to both the vessels at the rate of 1 mole/sec during the first two seconds only. It is observed that [P] (concentration of P) remains constant at the initial value in both the vessels during the addition. The volume change due to the addition of P is neglected and instantaneous mixing is assumed. The concentration ratio $[P]/[Q]$ at time, $t = 3$ sec in vessel Y is

Options :

- ✓ $1/3$
- ✗ $1/2$

✘ 2/3

✘ 3/4

Question Number : 31

The internal energy per mole of an ideal gas is denoted by E_{ideal} . The same for a real gas obeying van der Waals equation is E_{real} . Assuming the average kinetic energy of the molecules of the two gases at the same temperature to be equal, the correct statement for the gas at low pressure is

Options :

✔ $E_{\text{real}} < E_{\text{ideal}}$

✘ $E_{\text{real}} = E_{\text{ideal}}$

✘ E_{real} decreases for isothermal expansion

✘ E_{ideal} increases for isothermal expansion

Question Number : 32

Consider a cyclic process $P \rightarrow Q \rightarrow R \rightarrow P$ for a system. Among the following, the combination of steps that can **never** lead to this cyclic process is

Options :

$P \rightarrow Q$: Adiabatic irreversible; $Q \rightarrow R$: Adiabatic reversible; $R \rightarrow P$:

✔ Adiabatic reversible

$P \rightarrow Q$: Adiabatic irreversible; $Q \rightarrow R$: Adiabatic reversible; $R \rightarrow P$:

✘ Isothermal reversible

$P \rightarrow Q$: Adiabatic irreversible; $Q \rightarrow R$: Adiabatic reversible; $R \rightarrow P$:

✘ Isothermal irreversible

$P \rightarrow Q$: Isothermal irreversible; $Q \rightarrow R$: Isothermal reversible; $R \rightarrow P$:

✘ Isothermal reversible

Question Number : 33

Consider the following reaction.

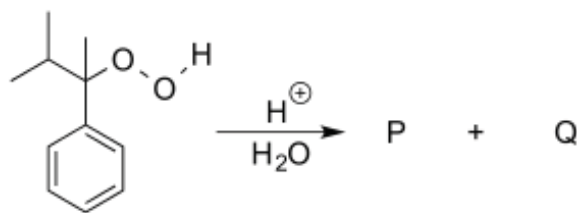

The major products P and Q of the reaction are

Options :

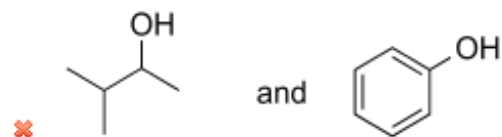
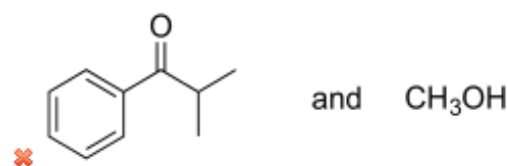
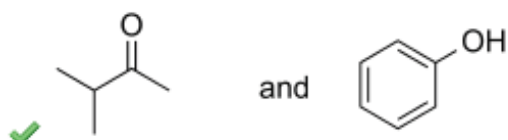
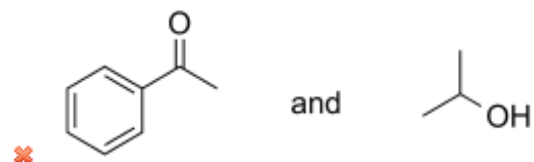

Question Number : 34

Carbocations are important intermediates in organic reactions, they are often stabilized by resonance, inductive effect and hyperconjugation. The cation that can be stabilized by hyperconjugation is

Options :

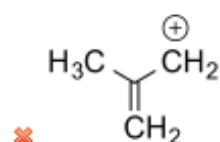
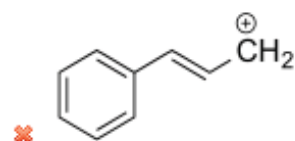

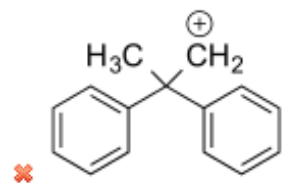
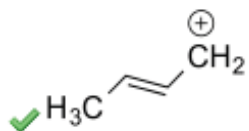

Question Number : 35

Hydrogenation of cyclohexene and benzene take place as shown below. The resonance energy of benzene is $-36 \text{ kcal mol}^{-1}$

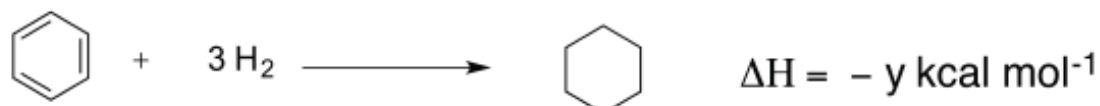
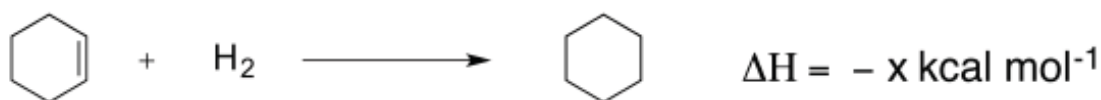

The relationship between x and y is

Options :

✗ $y = 3x$

✗ $y = 3x + 36$

✓ $y = 3x - 36$

✗ $y = 3x + 12$

Question Number : 36

Complexes $[\text{CoX}_6]^{3-}$, $[\text{CoY}_6]^{3+}$ and $[\text{CoZ}_6]^{3-}$ absorb at 700, 475 and _____ respectively. The ligands X, Y and Z most likely are, respectively,

Options :

- ✓ F^- , NH_3 , CN^-
- ✗ CN^- , H_2O , Cl^-
- ✗ Br^- , NH_3 , NCS^-
- ✗ I^- , H_2O , OH^-

Question Number : 37

Consider a catalyzed reaction $R \rightarrow P$. k_{cat} and k_{uncat} are the rate constants for the catalyzed and uncatalyzed reactions, respectively. However, the catalyst becomes inactive at temperature $T \geq 400$ K. The graph(s) that reasonably depict(s) the temperature dependence of the overall rate constant (k) is/are

Options :

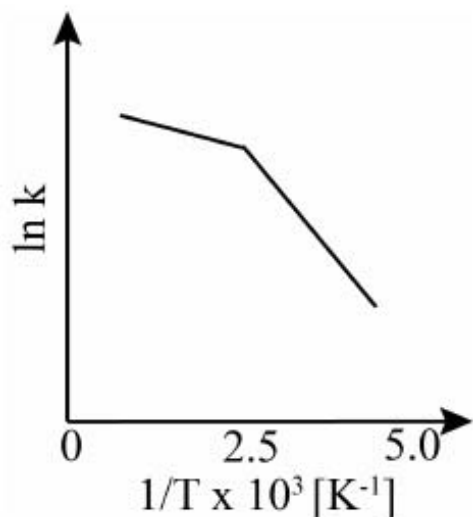

✗

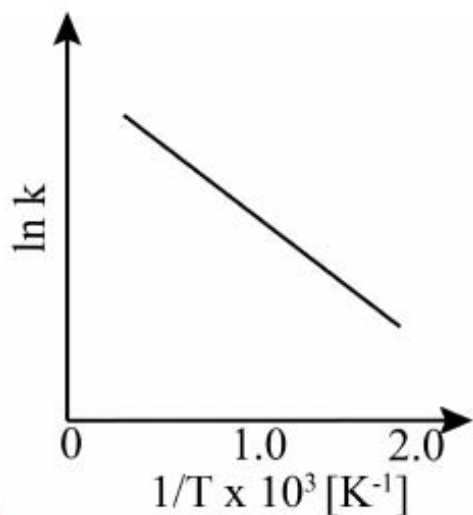

✓

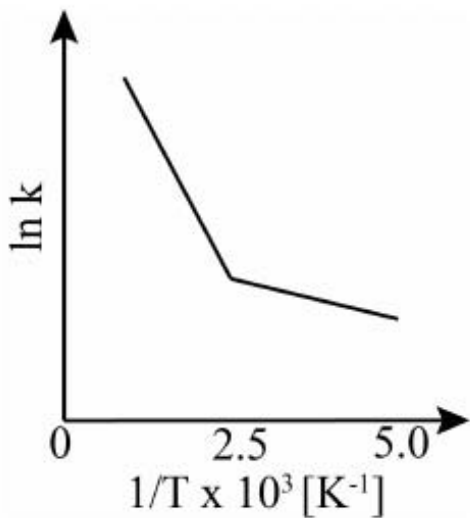

✘

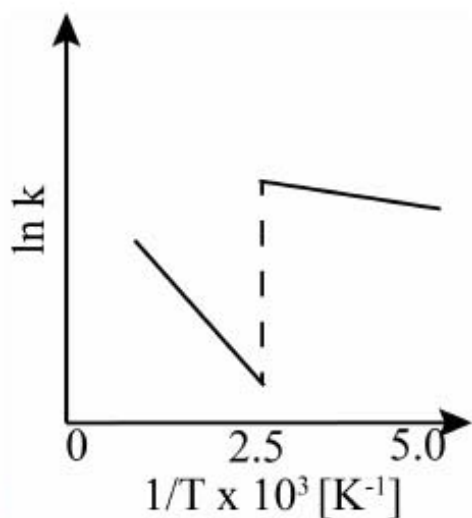

✔

Question Number : 38

Three separate reversible processes (1, 2 and 3) are carried out with 1 mole of an ideal gas initially at STP. In these processes, the pressure (P) is measured while increasing any one of the quantities volume (V), temperature (T) and number of moles (n), keeping the other two constant. Plots of P (atm) versus X are found to be linear, where $X = n$ or T (K) or $1/V$ (lit^{-1}). For the processes 1, 2 and 3, the numerical values of the slopes m_1 , m_2 and m_3 of the P versus X plots are found to follow the order $m_1 > m_2 > m_3$, respectively. The correct statement(s) about these processes is/are

Options :

- ✔ work done is zero for process 3
- ✔ heat is completely converted into work for process 1
- ✘ entropy remains constant in process 2

- ✗ the average speed of molecules remains constant for process 3

Question Number : 39

A homogeneous mixture of compounds P, Q, and R is spotted on a thin layer chromatography (TLC) plate. The TLC plate is made of acidic silica. The spotted TLC plate is placed in a closed jar containing diethyl ether as a mobile phase (eluent). As the eluent rises up the TLC plate, the compounds of the mixture separate and travel to different distances. The developed TLC plate is shown below.

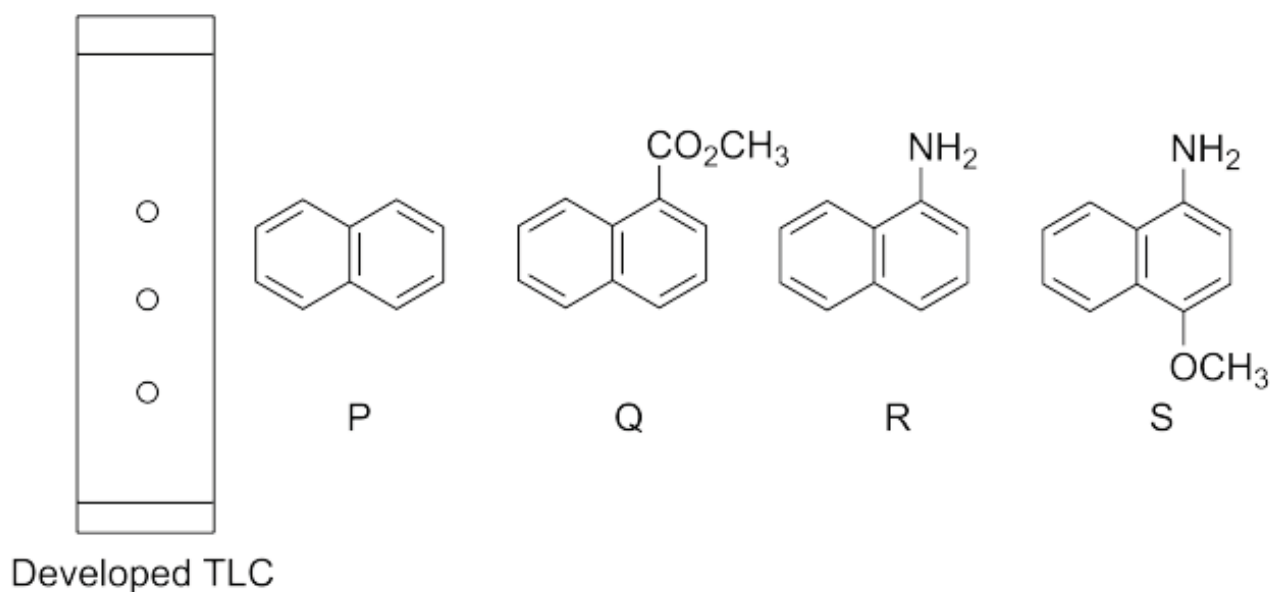

Based on the above information, the correct statement(s) is/are

Options :

- ✓ the separation of the compounds depends on their degree of adsorption
- ✗ the compound Q moves faster than the compound P
- ✓ the compound R moves slower than the compounds P and Q
- the compound S (see above figure) is expected to move slower than the
- ✓ compound R

Question Number : 40

Considering the following reaction,



the correct statement(s) is/are

Options :

if the concentration of allyl bromide is doubled, the rate of the reaction is doubled.

if the concentration of ethanol is doubled, the rate of the reaction is doubled.

if the concentration of allyl bromide and ethanol are doubled, the rate of the reaction is quadrupled.

if the concentration of allyl bromide and ethanol are doubled, the rate of the reaction is doubled.

Mathematics

Question Number : 41

Let $t_1 = 3$ and define $t_n = t_{n-1} + 2n + 1$ for all integers $n \geq 2$. Then t_{20} is

Options :

436

440

✘ 446

✘ 450

Question Number : 42

Suppose $2 + \sqrt{3}$ and $1 - i$ are roots of the equation $(x^2 + px + 1)(x^2 - 2x + q) = 0$ where p, q are integers and $i = \sqrt{-1}$. Then $p + q$ is

Options :

✘ -6

✔ -2

✘ 2

✘ 6

Question Number : 43

Suppose the coefficient of x^7 in $\left(ax^2 + \frac{1}{bx}\right)^{11}$ is equal to the coefficient of x^{-1} in $\left(ax - \frac{1}{bx^2}\right)^{11}$. Then

Options :

✘ $ab^2 = \frac{2}{3}$

✘ $a^2 = b$

✘ $a = b^2$

✔ $ab = \frac{7}{5}$

Question Number : 44

Let a, b, c be distinct real numbers such that $a^2 + b = b^2 + c = c^2 + a$. Then $(a + b)(b + c)(c + a)$ is

Options :

-1

0

1

8

Question Number : 45

Let $f, g : \mathbb{R} \rightarrow \mathbb{R}$ be such that $f'(x) = g(x)$ and $g'(x) = -f(x)$. Let $h(x) = f^2(x) + g^2(x)$. If $h(1) = 2018$ then $h(2018)$ is

Options :

$\frac{1}{2018}$

1

2018

2018^2

Question Number : 46

A bag contains 10 coins numbered $1, 2, 2^2, \dots, 2^9$. Three friends A, B and C play a game. First, A picks a coin randomly from the bag, notes down the number and returns it into the bag. Then B does the same, followed by C . The probability that the sum of the numbers obtained by A and B is equal to the number obtained by C is

Options :

0

$\frac{1}{1000}$

$\frac{9}{1000}$

$$\times \frac{1}{100}$$

Question Number : 47

Let R_1 and R_2 be two equivalence relations on a set S . Then the relation $R_1 \cup R_2$ on S is

Options :

- an equivalence relation.
- symmetric and transitive but not necessarily reflexive.
- reflexive and transitive but not necessarily symmetric.
- reflexive and symmetric but not necessarily transitive.

Question Number : 48

$$\int_{-1}^1 \frac{|x|}{1+e^x} dx \text{ is}$$

Options :

- 0
- $\frac{1}{2}$
- 1
- $e - \frac{1}{e}$

Question Number : 49

Let $ABCD$ be a rectangle and M be the midpoint of CD . Suppose AC and BD meet at O , AM and BD meet at X , BM and AC meet at Y . Then

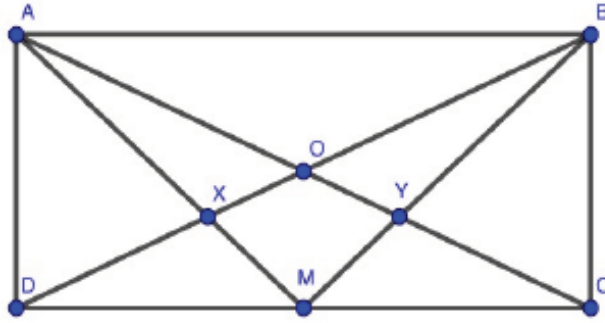

Options :

- $\text{Area}(\triangle AOX) > \text{Area}(OXMY)$
- $\text{Area}(\triangle AOX) < \text{Area}(OXMY)$
- $\text{Area}(\triangle AOX) = \text{Area}(OXMY) \iff ABCD$ is a square
- $\text{Area}(\triangle AOX) = \text{Area}(OXMY)$

Question Number : 50

Let $S = \{f: \mathbb{Q} \rightarrow \mathbb{Z} \mid f(x+y) = f(x) + f(y) \text{ for all } x, y \in \mathbb{Q}\}$ where \mathbb{Q} and \mathbb{Z} denote the set of rational numbers and integers respectively. The number of elements in S is

Options :

- 0
- 1
- 2
- not finite

Question Number : 51

Let $\phi_1, \phi_2: \mathbb{R} \rightarrow \mathbb{R}$ be non-constant and differentiable functions. Define $\vec{v} = \phi_1(t)\hat{i} + \phi_2(t)\hat{j}$ and $\frac{d\vec{v}}{dt} = \frac{d\phi_1(t)}{dt}\hat{i} + \frac{d\phi_2(t)}{dt}\hat{j}$. Then

Options :

✘ $\frac{d\vec{v}}{dt} = \vec{0}$

✔ $\vec{v} \cdot \frac{d\vec{v}}{dt} = 0 \implies |\vec{v}|$ is constant

✔ $|\vec{v}|$ is constant $\implies \vec{v} \cdot \frac{d\vec{v}}{dt} = 0$

✘ $\left| \frac{d\vec{v}}{dt} \right|$ is not constant for any choice of ϕ_1 and ϕ_2

Question Number : 52

Let $f, g: \mathbb{R} \rightarrow \mathbb{R}$ be such that $f(x) = x^k g(x)$ where k is a positive integer. Suppose g is continuous at $x = 0$. Then

Options :

✘ f is continuous at $x = 0$ but not differentiable at $x = 0$

✔ f is differentiable at $x = 0$

✘ $f'(0) = 0$ for every positive integer k

✔ $f'(0) = g(0)$ if $k = 1$ and $f'(0) = 0$ if $k \geq 2$

Question Number : 53

Let $z_1 = a + ib$ and $z_2 = c + id$ be complex numbers such that $|z_1| = |z_2| = 1$ and $\text{Re}(z_1 \bar{z}_2) = 0$. Then the complex numbers $w_1 = a + ic$ and $w_2 = b + id$ always satisfy

Options :

✔ $|w_1| = |w_2|$

✘ $\operatorname{Re}(w_1) = \operatorname{Im}(w_2)$

✔ $\operatorname{Re}(w_1 \overline{w_2}) = 0$

✔ $\operatorname{Re}(w_1 w_2) = 2\operatorname{Re}(w_1)\operatorname{Re}(w_2)$

Question Number : 54

For every $a \in \mathbb{R}$, let P_a be the parabola given by $y = x^2 + 2ax + a$. Then

Options :

✔ there is a common point which lies on P_a for each a

✘ there is no common point which lies on P_a for each a

✔ the vertex of the parabola P_a lies on the line $x = -a$

✔ the locus of the vertex of P_a is a parabola whose vertex is $\left(-\frac{1}{2}, \frac{1}{4}\right)$

Question Number : 55

Let $x_0 > 0$. For every natural number n define

$$s_n = \sin\left(\frac{\pi x_0^n}{1 + x_0^{2n}}\right) \text{ and } c_n = \cos\left(\frac{\pi x_0^n}{1 + x_0^{2n}}\right).$$

Then for all n

Options :

✔ $s_n^2 + c_n^2 = 1$

✔ $s_n \geq s_{n+1}$

✘ $c_n \geq c_{n+1}$

✔ $\frac{s_n}{c_n} \geq \frac{s_{n+1}}{c_{n+1}}$

Question Number : 56

A carrom coin of radius 1.5 cm and mass 5 g strikes the side of the board at an angle 30° with respect to the normal. The coin stays in contact with the side for 10^{-3} s and rebounds at an angle of 45° with respect to the normal. The initial speed of the coin is 1 m/s and its final speed is 0.7 m/s. The average impulsive force on the coin in the normal direction is about

Options :

✘ 2 N

✘ 4 N

✔ 7 N

✘ 14 N

Question Number : 57

A disc of mass M and radius R rolls without slipping on a horizontal surface (see figure).

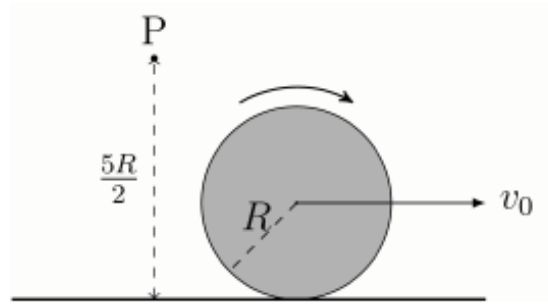

If the speed of its centre is v_0 , then the magnitude of the angular momentum of the disc about a fixed point P at a height $5R/2$ above the horizontal surface

Options :

✘ increases continuously as the disc moves away from P until it attains a constant value $\frac{5}{2}Mv_0R$.

✘ decreases continuously as the disc moves away from P until it attains a constant value $\frac{3}{2}Mv_0R$.

✔ is constant and equal to Mv_0R .

✘ is constant and equal to $2Mv_0R$.

Question Number : 58

The pressure (P) versus temperature (T) plot of a cyclic process for an ideal gas is shown in the figure.

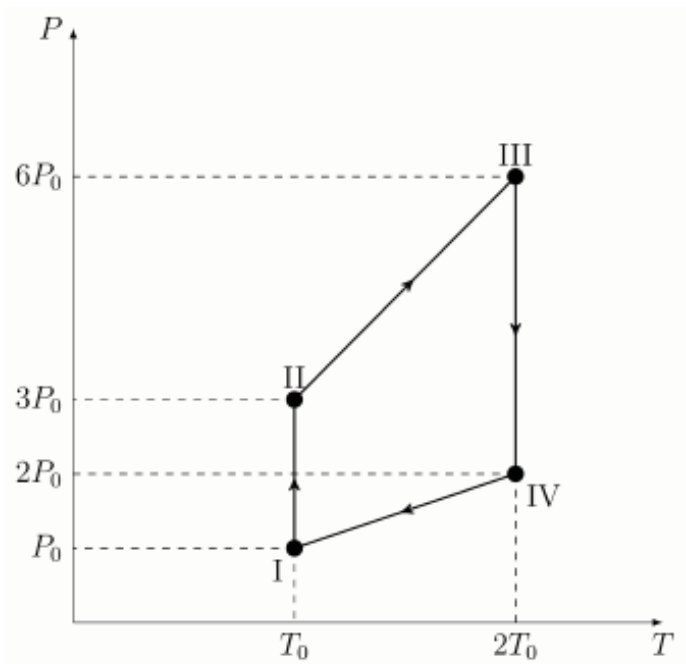

The corresponding density (ρ) versus temperature (T) plot will be

Options :

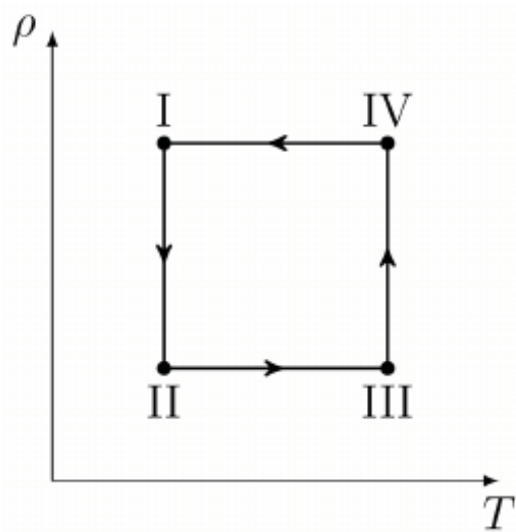

✘

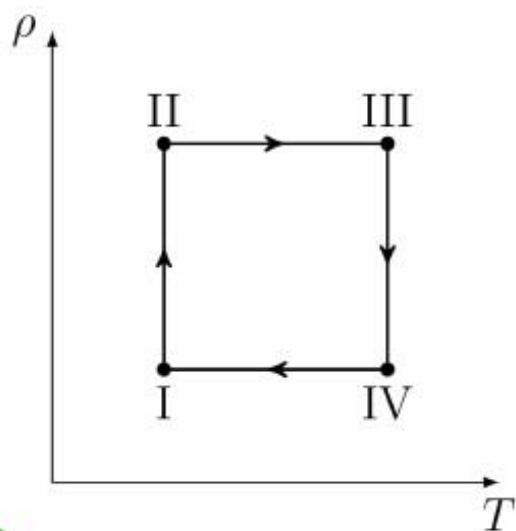

✔

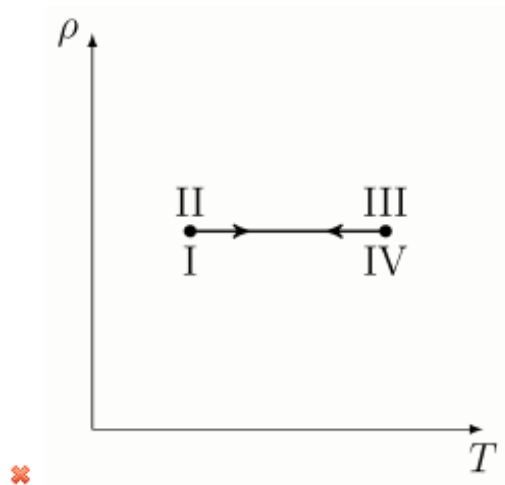
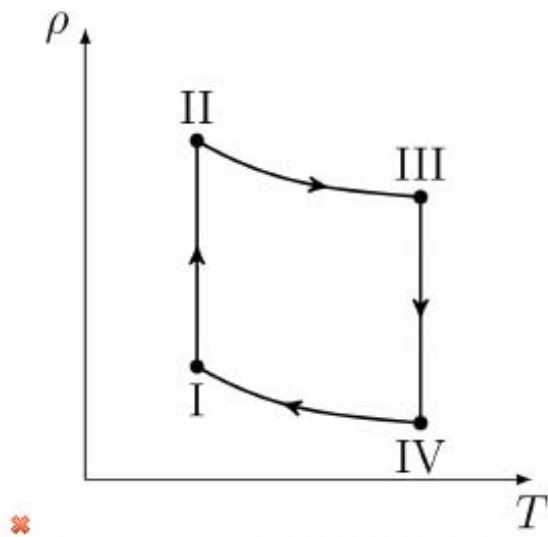

Question Number : 59

A thick walled, hollow metallic cylinder has height h and inner and outer radii r_1 and r_2 , respectively. It contains water which is heated with a constant power source so that its temperature is maintained at T_1 . In the steady state, the temperature of the inner and outer isothermal surfaces of the cylinder are T_1 and T_2 , respectively. The temperature difference $(T_1 - T_2)$ is proportional to

Options :

✘ $\frac{r_2 - r_1}{h(r_2 + r_1)}$

✔ $\frac{\ln(r_2/r_1)}{h}$

✘ $\frac{r_2 - r_1}{hr_2} \ln(r_2/r_1)$

$$\frac{r_2 - r_1}{r_2 r_1}$$

✘ $r_2 r_1$

Question Number : 60

A source of sound emitting at a frequency f is moving towards a wall with speed v_b . If v is the speed of sound then the beat frequency heard by a stationary observer behind the source is

Options :

✘ $\frac{v_b}{v - v_b} f$

✘ $\frac{v_b}{v + v_b} f$

✔ $\frac{2v_b v}{v^2 - v_b^2} f$

✘ $\frac{2v_b^2}{v^2 - v_b^2} f$

Question Number : 61

The distance between an object and a screen is 18 cm. A lens of focal length 4 cm is placed between them so that the image of the object is formed on the screen. Then

Options :

✘ the lens is 6 cm from the screen and the image is twice the size of the object.

✔ the lens is 12 cm from the screen and the image is twice the size of the object.

✘ the lens is 9 cm from the screen and the image is the same size as the object.

✘ the lens is 15 cm from the screen and the image is five times the size of the object.

Question Number : 62

A particle performs simple harmonic motion. A large number of snapshots of its position are taken at random. A histogram of these positions will

Options :

- have a minimum around the mean position.
- have a maximum around the mean position.
- resemble a sinusoidal curve.
- be almost flat.

Question Number : 63

Consider the circuit with an ideal p-n diode as shown. Let V_P be the voltage applied at the terminal P. The equivalent resistance between the terminals P and Q is R_1 when $V_P = +5.0\text{ V}$, and R_2 when $V_P = -5.0\text{ V}$.

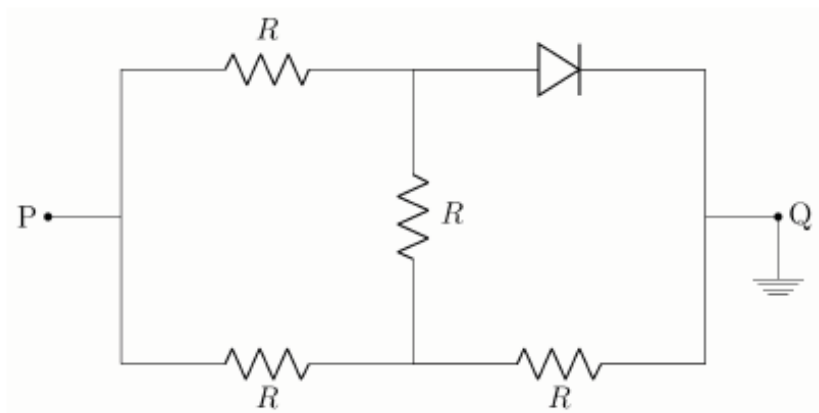

Then,

Options :

- $R_1 = \frac{5R}{3}$ and $R_2 = \frac{3R}{5}$
- $R_1 = \frac{3R}{5}$ and $R_2 = \frac{5R}{3}$
- $R_1 = \frac{2R}{3}$ and $R_2 = \frac{5R}{3}$

$$\times R_1 = \frac{5R}{3} \text{ and } R_2 = \frac{2R}{3}$$

Question Number : 64

Four infinitely long parallel wires pass through the four corners of a square PQRS of side a that lies in a plane perpendicular to the wires (see figure).

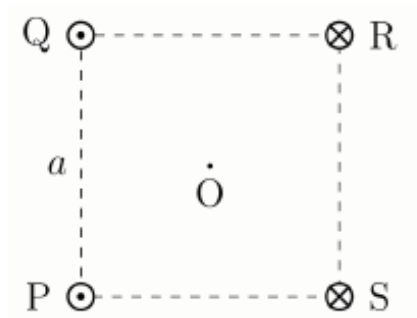

They all carry equal steady currents I . Currents in the wires passing through P and Q point out of the page, and the currents in the wires passing through R and S point into the page as shown in the figure. The magnitude of the magnetic field at the centre O of the square is

Options :

\times zero

\checkmark $\frac{2\mu_0 I}{\pi a}$

\times $\frac{2\sqrt{2}\mu_0 I}{\pi a}$

\times $\frac{\sqrt{2}\mu_0 I}{\pi a}$

Question Number : 65

Consider two semi-infinite flat plates lying parallel to the xy -plane at $z = +d$ and $z = -d$, carrying uniform surface charge densities $+\sigma$ and $-\sigma$, respectively. The plates extend from $x = 0$ to $x = -\infty$ and from $y = -\infty$ to $y = +\infty$. The direction of the electric field at a point whose coordinates are $(0,0,2d)$ is along

Options :

\hat{k}

\hat{i}

$-\hat{i}$

$\hat{i} + \hat{k}$

Question Number : 66

A solenoid is constructed by winding a wire of diameter d around a cylinder of a fixed height h and a fixed radius r ($h \gg r \gg d$) such that a magnetic field of a fixed magnitude B is produced along the axis of the cylinder when an appropriate current is passed through the wire. The winding must be tight, with negligible space left between adjacent turns, and there is only one layer of wire on the cylinder. Choose the correct statement(s).

Options :

The number of turns per unit length is proportional to $1/d$.

The resistance of the wire is proportional to $1/d$.

The current required to be passed through the wire is proportional to $1/d$.

The heat produced in the wire when the requisite current is passed through it is proportional to $1/d$.

Question Number : 67

A tuning fork is used to set up a wave in a pipe of length L closed at one end (see figure).

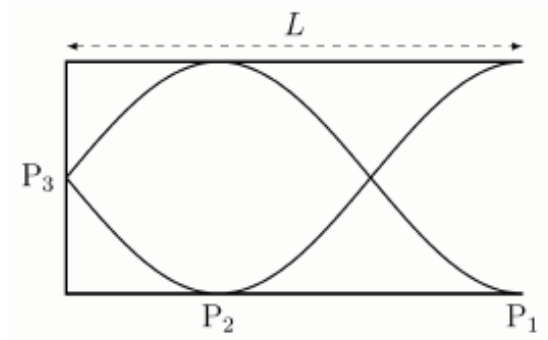

Then,

Options :

✗ the wavelength is $\lambda = 3L/2$.

✓ P_3 is a displacement node and the displacement is zero at P_3 .

✗ P_2 is a pressure node and the pressure is zero at P_2 .

✓ the arrangement can be used to obtain the speed of sound in air.

Question Number : 68

Two solid blocks at temperatures T_1 and T_2 ($T_1 < T_2$) are put in thermal contact for a long time inside an insulated container. Choose the correct statement(s).

Options :

Subsequent spontaneous regaining of the initial temperatures by the two blocks does not violate the first law of thermodynamics.

The amount of energy released by the hot block is equal to the amount absorbed by the cold block.

The entropy of the system is maximum when thermal equilibrium is attained.

The decrease in entropy of the hot block is equal in magnitude to the increase in entropy of the cold block.

Question Number : 69

A particle executes simple harmonic motion with time period T , amplitude A and maximum speed V_m . The particle is at the mean position when $t = 0$. If y is the displacement from the mean position and v is the speed, then choose the correct statement(s) from the following in the time interval $0 \leq t \leq T/4$.

Options :

✓ For $v = V_m/2$, $y > A/2$

✗ At $y = A/2$, the kinetic and potential energies are equal.

✓ The magnitude of the acceleration at $y = A/2$ is twice that at $y = A/4$.

✓ At $t = T/8$, $y > A/2$

Question Number : 70

The force acting on a particle is given by $\alpha\vec{\beta} \times \vec{p}$ where α is a constant, $\vec{\beta}$ is a constant vector of magnitude β and \vec{p} is the linear momentum of the particle. Then

Options :

✗ the dimension of $\alpha\beta$ is $[M \cdot T^{-1}]$.

✓ the component of \vec{p} along $\vec{\beta}$ is a constant.

✓ \vec{p} is perpendicular to $d\vec{p}/dt$.

✓ the magnitude of \vec{p} is a constant.