

DU MSc Electronics

Topic:- ELEC MSC S2

1) The equation of the plane through the points $(1, -1, 2)$, $(1, 1, -2)$ and $(-1, 1, 2)$ is

[Question ID = 1584]

1. $x + 3y + 2z - 2 = 0$

[Option ID = 6330]

2. $x - y + 2z - 2 = 0$

[Option ID = 6331]

3. $2x + 2y + z - 2 = 0$

[Option ID = 6332]

4. $x + y - z - 2 = 0$

[Option ID = 6333]

Correct Answer :-

• $2x + 2y + z - 2 = 0$

[Option ID = 6332]

2) Unit vector perpendicular to $\hat{A} = 3\hat{i} + \hat{j} + 2\hat{k}$ and $\hat{B} = 2\hat{i} - 2\hat{j} + 4\hat{k}$ vectors is

[Question ID = 1585]

1. $\pm \frac{1}{\sqrt{3}}(-\hat{i} - \hat{j} - \hat{k})$

[Option ID = 6334]

2. $\pm \frac{1}{\sqrt{3}}(\hat{i} + \hat{j} + \hat{k})$

[Option ID = 6335]

3. $\pm \frac{1}{\sqrt{3}}(\hat{i} - \hat{j} + \hat{k})$

[Option ID = 6336]

4. $\pm \frac{1}{\sqrt{3}}(\hat{i} - \hat{j} - \hat{k})$

[Option ID = 6337]

Correct Answer :-

• $\pm \frac{1}{\sqrt{3}}(\hat{i} - \hat{j} - \hat{k})$

[Option ID = 6337]

3) The two complex numbers $Z_1 = 2 + i^2/\sqrt{3}$ and $Z_2 = \sqrt{3} + i$. The argument of $\frac{Z_1}{Z_2}$ in degree is ____

[Question ID = 1586]

1. 0°

[Option ID = 6338]

2. 90°

[Option ID = 6339]

3. 30°

[Option ID = 6340]

4. 60°

[Option ID = 6341]

Correct Answer :-

• 0°

[Option ID = 6338]

4) The value of given definite integral $\int_0^{\frac{\pi}{2}} \sin 2x \log(\tan x) dx$ is

[Question ID = 1587]

1. 1

[Option ID = 6342]

2. 0

[Option ID = 6343]

3. π

[Option ID = 6344]

4. $-\pi$

[Option ID = 6345]

Correct Answer :-

• 0

[Option ID = 6343]

5) If we differentiate the $f(x) = x^x$ then $\frac{df}{dx} =$

[Question ID = 1588]

1. $1 + \log x$

[Option ID = 6346]

2. $-x^x(1 + \log x)$

[Option ID = 6347]

3. $x^x(1 + \log x)$

[Option ID = 6348]

4. $x^x(\log x)$

[Option ID = 6349]

Correct Answer :-

• $x^x(1 + \log x)$

[Option ID = 6348]

6) The absolute maximum and minimum values points of $x^3 - 6x^2 + 9x - 7$ in $[0, 5]$ are

[Question ID = 1589]

1. the point of maxima is 3 and the point of minima is 5

[Option ID = 6350]

2. the point of maxima is 5 and the point of minima is 0

[Option ID = 6351]

3. the point of maxima is 5 and the point of minima is 3

[Option ID = 6352]

4. There is no maxima and minima points in $[0, 5]$

[Option ID = 6353]

Correct Answer :-

• the point of maxima is 5 and the point of minima is 3

[Option ID = 6352]

7) The Laplace transform of given unit step function $f(t - \beta) = \begin{cases} 0 & t < \beta \\ 1 & t > \beta \end{cases}$ is

[Question ID = 1590]

1. $\beta \frac{e^{-2s}}{s}$

[Option ID = 6354]

2. $\frac{e^{-\beta s}}{s}$

[Option ID = 6355]

3. $\beta s e^{-2s}$

[Option ID = 6356]

4. e^{-2s}

[Option ID = 6357]

Correct Answer :-

• $\frac{e^{-\beta s}}{s}$

[Option ID = 6355]

8) If 2 and 4 are the eigen values of square matrix A then the Eigen values of A^T are

[Question ID = 1591]

1. 0.5, 0.25 [Option ID = 6358]

2. 2, 4 [Option ID = 6359]

3. 4, 16 [Option ID = 6360]

4. 3, 2 [Option ID = 6361]

Correct Answer :-

• 2, 4 [Option ID = 6359]

9) The system of equation $x - 2y + z = 0$, $2x - y + 3z = 0$ and $\lambda x + y - z = 0$ has non zero solution, if λ is

[Question ID = 1592]

1. $\lambda = 0.4$ [Option ID = 6362]

2. $\lambda = -2$ [Option ID = 6363]

3. $\lambda = 2$ [Option ID = 6364]

4. $\lambda = -0.8$ [Option ID = 6365]

Correct Answer :-

• $\lambda = -0.8$ [Option ID = 6365]

10) If A is skew-Hermitian, then (iA) is

[Question ID = 1593]

1. Skew-symmetric [Option ID = 6366]

2. Symmetric [Option ID = 6367]

3. Hermitian [Option ID = 6368]

4. Skew-Hermitian [Option ID = 6369]

Correct Answer :-

• Hermitian [Option ID = 6368]

11) The integrating factor of the differential equation $\frac{dy}{dx} + \frac{y}{x} = x^3 - 3$ is

[Question ID = 1594]

1. -x

[Option ID = 6370]

2. $x \log x$

[Option ID = 6371]

3. x

[Option ID = 6372]

4. $\log x$

[Option ID = 6373]

Correct Answer :-

• x

[Option ID = 6372]

12) The solution of $\frac{dy}{dx} - y \tan x = y^2 \sec x$ is given by:-

[Question ID = 1595]

1. $y^{-1} = \sin x + c_1 \cos x$

[Option ID = 6374]

2. $y^{-1} = \cos x + c_3 \sin x$

[Option ID = 6375]

3. $y^{-1} = -\cos x + c_4 \sin x$

[Option ID = 6376]

4. $y^{-1} = -\sin x + c_2 \cos x$

[Option ID = 6377]

Correct Answer :-

• $y^{-1} = -\sin x + c_2 \cos x$

[Option ID = 6377]

13) The family of conic represented by the solution of the differential equation $(4x + 3y + 1) dx + (3x + 2y + 1) dy = 0$ is

[Question ID = 1596]

1. Parabolas [Option ID = 6378]
2. Circle [Option ID = 6379]
3. Ellipses [Option ID = 6380]
4. Hyperbola [Option ID = 6381]

Correct Answer :-

- Hyperbola [Option ID = 6381]

14) The function $f(x) = x^3 - 6x^2 + 9x + 25$

[Question ID = 1597]

1. maxima at $x = 1$ and a minima at $x = 3$ [Option ID = 6382]
2. a maxima at $x = 3$ and a minima at $x = 1$ [Option ID = 6383]
3. no maxima, but a minima at $x = 1$ [Option ID = 6384]
4. a maxima at $x = 1$, but no minima [Option ID = 6385]

Correct Answer :-

- maxima at $x = 1$ and a minima at $x = 3$ [Option ID = 6382]

15) Consider an optical fiber of $75 \mu\text{m}$ diameter, core index $n_1 = 1.5$, and cladding index $n_2 = 1.49$ for operation at $\lambda = 1.31 \mu\text{m}$. How many modes does this fiber support?

[Question ID = 1598]

1. 244 [Option ID = 6386]
2. 312 [Option ID = 6387]
3. 484 [Option ID = 6388]
4. 188 [Option ID = 6389]

Correct Answer :-

- 484 [Option ID = 6388]

16) When a LED has 2 V applied to its terminals, it draws 100 mA and produces 4 mW of optical power. The LED conversion efficiency from electrical to optical power is:-

[Question ID = 1599]

1. 3% [Option ID = 6390]
2. 4% [Option ID = 6391]
3. 5% [Option ID = 6392]
4. 2% [Option ID = 6393]

Correct Answer :-

- 2% [Option ID = 6393]

17) Number of electron-hole pairs generated divided by the number of photons is:-

[Question ID = 1600]

1. Dark current [Option ID = 6394]
2. Quantum response [Option ID = 6395]
3. Photo sensitivity [Option ID = 6396]
4. Quantum efficiency [Option ID = 6397]

Correct Answer :-

- Quantum efficiency [Option ID = 6397]

18) If the refractive index of a media is 1.5, the velocity of light in the medium is:-

[Question ID = 1601]

1. 3×10^8 m/s [Option ID = 6398]
2. 1.5×10^8 m/s [Option ID = 6399]
3. 1×10^8 m/s [Option ID = 6400]
4. 2×10^8 m/s [Option ID = 6401]

Correct Answer :-

- 2×10^8 m/s [Option ID = 6401]

19) In C language, what is the output of the following code

```
int main()
```

```
{  
int a = 4, b = 7,c; c = a == b; printf("%i",c);  
}
```

[Question ID = 1602]

1. 1

[Option ID = 6402]

2. 0

[Option ID = 6403]

3. error

[Option ID = 6404]

4. 4

[Option ID = 6405]

Correct Answer :-

• 0

[Option ID = 6403]

20) In C language, what is the output of the following code

```
int main()  
{  
int i = 4;  
printf("%d%d",i,i++);  
}
```

[Question ID = 1603]

1. 54

[Option ID = 6406]

2. 45

[Option ID = 6407]

3. 44

[Option ID = 6408]

4. 55

[Option ID = 6409]

Correct Answer :-

• 54

[Option ID = 6406]

21) In C language, what is the output of the following code

```
int main()  
{  
int a = 63, b = 9;  
printf("%d",a>>a/b-2);  
}
```

[Question ID = 1604]

1. 1

[Option ID = 6410]

2. 2

[Option ID = 6411]

3. 3

[Option ID = 6412]

4. None of these

[Option ID = 6413]

Correct Answer :-

• 1

[Option ID = 6410]

22) In C language, what is the output of the following code

```
main()
{
int x;
x = 4;
while ( x > 1)
{
printf("%d",x);
x=x-1;
}
}
```

[Question ID = 1605]

1. 4323

[Option ID = 6414]

2. 432

[Option ID = 6415]

3. 4321

[Option ID = 6416]

4. 3215

[Option ID = 6417]

Correct Answer :-

- 432

[Option ID = 6415]

23) In C “switch” statement, each case instance value must be:-

[Question ID = 1606]

1. constant

[Option ID = 6418]

2. Variable

[Option ID = 6419]

3. Special symbol

[Option ID = 6420]

4. None of these

[Option ID = 6421]

Correct Answer :-

- constant

[Option ID = 6418]

24) If mobility of an electrons in Si at 300 K is $0.16 \text{ m}^2/\text{V}\cdot\text{s}$ then the diffusion coefficient of electrons is:-

[Question ID = 1607]

1. $20.7 \times 10^{-4} \text{ m}^2/\text{s}$ [Option ID = 6422]

2. $62.1 \times 10^{-4} \text{ m}^2/\text{s}$ [Option ID = 6423]

3. $6.4 \times 10^{-2} \text{ m}^2/\text{s}$ [Option ID = 6424]

4. $41.4 \times 10^{-4} \text{ m}^2/\text{s}$ [Option ID = 6425]

Correct Answer :-

- $41.4 \times 10^{-4} \text{ m}^2/\text{s}$ [Option ID = 6425]

25) If an electric field of 45 V/m is applied to a semiconductor sample whose Hall coefficient is $0.04 \text{ m}^3/\text{C}$ then the current density in the sample is _____ (Given: $\mu_n = 0.36 \text{ m}^2/\text{V}$)

[Question ID = 1608]

1. 203 A/cm^2 [Option ID = 6426]

2. 814 A/m^2 [Option ID = 6427]

3. 414 A/m^2 [Option ID = 6428]

4. 650 A/cm^2 [Option ID = 6429]

Correct Answer :-

- 414 A/m^2 [Option ID = 6428]

26) In a p-type GaAs sample electrons are injected from a contact. If the minority carrier mobility is $8000 \text{ cm}^2/\text{V}\cdot\text{s}$ at 300 K and the radiation recombination time 0.3 ns then the diffusion length for the electron is:-

[Question ID = 1609]

1. $2.50 \mu\text{m}$ [Option ID = 6430]
2. $1.25 \mu\text{m}$ [Option ID = 6431]
3. $5.00 \mu\text{m}$ [Option ID = 6432]
4. $7.98 \mu\text{m}$ [Option ID = 6433]

Correct Answer :-

- $2.50 \mu\text{m}$ [Option ID = 6430]

27) Consider a $10 \mu\text{m}$ diameter p-n junction fabricated in Si. If donor density is $10^{15} /\text{cm}^3$ and acceptor density is $10^{16} /\text{cm}^3$ then built in potential in the p-n junction is (Given: intrinsic carrier concentration for Si = $1.75 \times 10^{10} /\text{cm}^3$)

[Question ID = 1610]

1. 0.31 V [Option ID = 6434]
2. 1.12 V [Option ID = 6435]
3. 1.42 V [Option ID = 6436]
4. 0.63 V [Option ID = 6437]

Correct Answer :-

- 0.63 V [Option ID = 6437]

28) In an n-type GaAs crystal at 300 K, the electron concentration varies as $n(x) = 1.5 \times 10^{15} \exp\left(-\frac{x}{L}\right) /\text{cm}^2$. If the electron diffusion co-efficient is $250 \text{ cm}^2/\text{s}$ then the diffusion current density at $x = 0$ is _____ (where $L = 1.5 \mu\text{m}$ and $x > 0$)

[Question ID = 1611]

1. $1.5 \text{ kA}/\text{cm}^2$
[Option ID = 6438]
2. $1.0 \text{ kA}/\text{cm}^2$
[Option ID = 6439]
3. $10.0 \text{ kA}/\text{cm}^2$
[Option ID = 6440]
4. $0.4 \text{ kA}/\text{cm}^2$
[Option ID = 6441]

Correct Answer :-

- $0.4 \text{ kA}/\text{cm}^2$
[Option ID = 6441]

29) In a MOSFET the transfer characteristics are used to determine which of the following device parameter?

[Question ID = 1612]

1. threshold voltage and output resistance [Option ID = 6442]
2. threshold voltage and transconductance [Option ID = 6443]
3. transconductance and output resistance [Option ID = 6444]
4. transconductance and channel length modulation [Option ID = 6445]

Correct Answer :-

- threshold voltage and transconductance [Option ID = 6443]

30) The maximum voltage gain obtained from FET having $g_m = 5 \text{ mS}$ and $r_d = 20 \text{ k}\Omega$ is ____

[Question ID = 1613]

1. 100 [Option ID = 6446]
2. 10 [Option ID = 6447]
3. 0 [Option ID = 6448]
4. infinity [Option ID = 6449]

Correct Answer :-

- 100 [Option ID = 6446]

31) The drain of n-channel MOSFET is shorted to the gate and threshold voltage is 1.5V. If the drain current (I_D) is 2 mA for $V_{GS} = 2.5 \text{ V}$ then for $V_{GS} = 3.5 \text{ V}$ the I_D is _____.

[Question ID = 1614]

1. 2 mA [Option ID = 6450]
2. 4 mA [Option ID = 6451]
3. 8 mA [Option ID = 6452]
4. 1 mA [Option ID = 6453]

Correct Answer :-

- 8 mA [Option ID = 6452]

32) If a BJT has base current $250 \mu\text{A}$ and emitter current of 15 mA then its collector current and β are:-

[Question ID = 1615]

1. $14.75 \mu\text{A}$ and 99 [Option ID = 6454]
2. 14.75 A and 59 [Option ID = 6455]
3. $14.75 \mu\text{A}$ and 99.8 [Option ID = 6456]
4. 14.75 mA and 59 [Option ID = 6457]

Correct Answer :-

- 14.75 mA and 59 [Option ID = 6457]

33) For the following Lissajous figure, the ratio of frequencies of signals applied to two inputs of CRO is

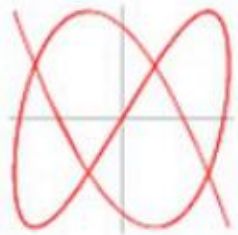

[Question ID = 1616]

1. $3/2$
[Option ID = 6458]
2. $3/4$
[Option ID = 6459]
3. $2/3$
[Option ID = 6460]
4. $5/3$
[Option ID = 6461]

Correct Answer :-

- $5/3$
[Option ID = 6461]

34) Electrical Zero Position (EZP) in Linear Variable Differential Transformer (LVDT) is:-

[Question ID = 1617]

1. Position of primary winding coil [Option ID = 6462]
2. Position of secondary winding coil [Option ID = 6463]
3. Position of core [Option ID = 6464]
4. Position of ac input voltage terminal [Option ID = 6465]

Correct Answer :-

- Position of core [Option ID = 6464]

35) A half-wave rectifier type AC voltage meter is fed with a $10 V_{\text{rms}}$ signal. The equivalent DC output (V_{dc}) is:-

[Question ID = 1618]

1. 9 V [Option ID = 6466]
2. 15 V [Option ID = 6467]
3. 4.5 V [Option ID = 6468]
4. 6.7 V [Option ID = 6469]

Correct Answer :-

- 4.5 V [Option ID = 6468]

36) The voltage output of a Hall-Effect transducer is 5 mV . If the plate is made of Si whose Hall coefficient is $6 \times 10^{-6} \text{ Vm/AT}$ (where T: Tesla), given plate thickness is 2 mm and the current passing through the plate is 2 A . The value of flux density is:-

[Question ID = 1619]

1. 0.83 T
[Option ID = 6470]
2. 1.2 T
[Option ID = 6471]
3. 1.66 T
[Option ID = 6472]
4. 2.44 T
[Option ID = 6473]

Correct Answer :-

- 0.83 T

[Option ID = 6470]

37) One Hartley oscillator circuit has two inductors of 0.5 mH and each is tuned to resonate with a capacitor which can be varied from 100 pF to 500 pF, the upper and lower frequencies of oscillation are, respectively:-

[Question ID = 1620]

1. 712 kHz, 225 kHz [Option ID = 6474]
2. 503 kHz, 318 kHz [Option ID = 6475]
3. 503 kHz, 225 kHz [Option ID = 6476]
4. 712 kHz, 318 kHz [Option ID = 6477]

Correct Answer :-

- 503 kHz, 225 kHz [Option ID = 6476]

38) A source alphabet consists of N symbols with the probability of the first two symbols being the same. A source encoder increases the probability of the first symbol by a small amount and decreases the probability of the second by same amount. After encoding, the entropy of the source

[Question ID = 1621]

1. Increases [Option ID = 6478]
2. Remains the same [Option ID = 6479]
3. Increases only if N=2 [Option ID = 6480]
4. decreases [Option ID = 6481]

Correct Answer :-

- decreases [Option ID = 6481]

39) The nyquist sampling rate for the signal $s(t) = \frac{\sin(500\pi t)}{\pi t} \times \frac{\sin(700\pi t)}{\pi t}$ is given by

[Question ID = 1622]

1. 600 Hz
[Option ID = 6482]
2. 400 Hz
[Option ID = 6483]
3. 1200 Hz
[Option ID = 6484]
4. 1400 Hz
[Option ID = 6485]

Correct Answer :-

- 1200 Hz

[Option ID = 6484]

40) Source encoding in a data communication system is done in order to:-

[Question ID = 1623]

1. enhance the information transmission [Option ID = 6486]
2. bandpass filters and envelop rate detectors [Option ID = 6487]
3. conserve the transmitted power [Option ID = 6488]
4. discriminator detection [Option ID = 6489]

Correct Answer :-

- enhance the information transmission [Option ID = 6486]

41) Consider the signal

$S(t) = m(t) \cos(2\pi f_c t) + \hat{m}(t) \sin(2\pi f_c t)$ where $\hat{m}(t)$ denotes the Hilbert transform of $m(t)$ and the bandwidth of $m(t)$ is very small compared to f_c . The signal $s(t)$ is a

[Question ID = 1624]

1. band pass signal
[Option ID = 6490]
2. low pass signal
[Option ID = 6491]
3. high pass signal
[Option ID = 6492]
4. double sideband suppressed carrier signal

[Option ID = 6493]

Correct Answer :-

- band pass signal

[Option ID = 6490]

42) Consider the frequency modulated signal $10 \cos [2\pi \cdot 10^5 t + 5 \sin(2\pi \cdot 1500 t) + 7.5 \sin(2\pi \cdot 1000 t)]$ with carrier frequency of 10^5 Hz. The modulation index is:-

[Question ID = 1625]

1. 12.5

[Option ID = 6494]

2. 7.5

[Option ID = 6495]

3. 5

[Option ID = 6496]

4. 10

[Option ID = 6497]

Correct Answer :-

- 10

[Option ID = 6497]

43) Match List I with List II

List I	List II
Operations	Function
A. Comanding	I. Improving image rejection
B. Squelch	II. Variation of step size in quantization
C. Preemphasis	III. Muting the receiver
D. Double conversion	IV. Boosting of higher modulating frequencies at the transmitter

Choose the correct answer from the options given below:

[Question ID = 1626]

1. A - II, B - III, C - IV, D - I

[Option ID = 6498]

2. A - II, B - I, C - IV, D - III

[Option ID = 6499]

3. A - IV, B - III, C - II, D - I

[Option ID = 6500]

4. A - IV, B - I, C - II, D - III

[Option ID = 6501]

Correct Answer :-

- A - II, B - III, C - IV, D - I

[Option ID = 6498]

44) The ramp signal $m(t) = at$ is applied to delta modulator with sampling period T_s and step size δ . Slope overload distortion would occur if:-

[Question ID = 1627]

1. $\delta < a$

[Option ID = 6502]

2. $\delta > a$

[Option ID = 6503]

3. $\delta > a T_s$

[Option ID = 6504]

4. $\delta < a T_s$

[Option ID = 6505]

Correct Answer :-

- $\delta < a T_s$

[Option ID = 6505]

45) A voltage of 1 volt rms is applied at the sending end of a telephone cable of length 2000 meters. The attenuation in the cable is 1 dB/m. What will be the rms voltage at receiving end of the cable?

[Question ID = 1628]

1. 10^{100} volt [Option ID = 6506]
2. 10^{50} volt [Option ID = 6507]
3. 10^{-100} volt [Option ID = 6508]
4. 10^{-50} volt [Option ID = 6509]

Correct Answer :-

- 10^{-100} volt [Option ID = 6508]

46) In PCM system, if the quantization levels are increased from 3 to 9, the relative bandwidth requirement will:-

[Question ID = 1629]

1. be doubled [Option ID = 6510]
2. be tripled [Option ID = 6511]
3. remain same [Option ID = 6512]
4. become four times [Option ID = 6513]

Correct Answer :-

- be doubled [Option ID = 6510]

47) The Nyquist sampling rate for the signal $s(t) = \frac{\sin(50\pi t)}{\pi t} \times \frac{\sin(80\pi t)}{\pi t}$ is given by

[Question ID = 1630]

1. 120 Hz
[Option ID = 6514]
2. 130 Hz
[Option ID = 6515]
3. 80 Hz
[Option ID = 6516]
4. 40 Hz
[Option ID = 6517]

Correct Answer :-

- 130 Hz
[Option ID = 6515]

48) A system has three stage cascaded amplifier each stage having a power gain of 10 dB and noise figure of 6 dB. the overall noise figure is:-

[Question ID = 1631]

1. 1 [Option ID = 6518]
2. 0 [Option ID = 6519]
3. 10 [Option ID = 6520]
4. 20 [Option ID = 6521]

Correct Answer :-

- 1 [Option ID = 6518]

49) A 2 MHz carrier is amplitude modulated by a 500 Hz modulating signal to a depth of 60%. If the unmodulated carrier power is 2 kW, the power of the modulated signal is:-

[Question ID = 1632]

1. 1 kW [Option ID = 6522]
2. 2.17 kW [Option ID = 6523]
3. 4.45 kW [Option ID = 6524]
4. 22 kW [Option ID = 6525]

Correct Answer :-

- 2.17 kW [Option ID = 6523]

50) A 1000 KHz carrier is simultaneously modulated with 300 Hz, 800 Hz and 2 KHz signals. Which of the following is least likely to be present in the output?

[Question ID = 1633]

1. 1002 KHz [Option ID = 6526]
2. 1000 KHz [Option ID = 6527]
3. 999.2 KHz [Option ID = 6528]
4. 998.0 KHz [Option ID = 6529]

Correct Answer :-

- 1000 KHz [Option ID = 6527]

51) The positive peak of an AM wave is 16 V and the minimum value is 4 V. Assuming single tone modulation, the modulation index is:-

[Question ID = 1634]

1. 0.25 [Option ID = 6530]
2. 4 [Option ID = 6531]
3. 0.36 [Option ID = 6532]
4. 0.6 [Option ID = 6533]

Correct Answer :-

- 0.6 [Option ID = 6533]

52) 24 channels are to be time multiplexed using PCM. If the sampling frequency is 10 KHz and the number of quantization levels is 128, the required bandwidth of PCM is:-

[Question ID = 1635]

1. 240 KHz [Option ID = 6534]
2. 1.68 MHz [Option ID = 6535]
3. 81.6 KHz [Option ID = 6536]
4. 3.072 MHz [Option ID = 6537]

Correct Answer :-

- 1.68 MHz [Option ID = 6535]

53) Square law modulators utilizes:-

[Question ID = 1636]

1. Non Linear range of V-I characteristics of triode [Option ID = 6538]
2. Non-linear range of V-I characteristics of diode [Option ID = 6539]
3. Linear range of V-I characteristics of diode [Option ID = 6540]
4. Linear range of V-I characteristics of triode [Option ID = 6541]

Correct Answer :-

- Non-linear range of V-I characteristics of diode [Option ID = 6539]

54) A particular material has 3×10^{24} atoms/m³ and each atom has a dipole moment of $2.5 \times 10^{-25} \hat{u}_y$ Am². The magnetic field intensity \vec{H} material with $\mu_r = 6$ is

[Question ID = 1637]

1. $0.15 \hat{u}_y$ A/m

[Option ID = 6542]

2. $0.22 \hat{u}_y$ A/m

[Option ID = 6543]

3. $0.75 \hat{u}_y$ A/m

[Option ID = 6544]

4. $2.04 \hat{u}_y$ A/m

[Option ID = 6545]

Correct Answer :-

- $0.15 \hat{u}_y$ A/m

[Option ID = 6542]

55) In the following figure, the field E_1 makes an angle of θ_1 with the axis normal to the boundary line, while the field E_2 makes an angle of θ_2 in medium 2. The ratio of normal components of E_2 over E_1 (E_{n2}/E_{n1}) is

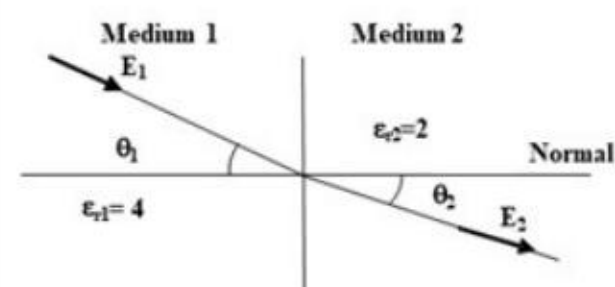

[Question ID = 1638]

1. 1/2

[Option ID = 6546]

2. 4

[Option ID = 6547]

3. 2

[Option ID = 6548]

4. 1/4

[Option ID = 6549]

Correct Answer :-

- 2

[Option ID = 6548]

56) If the flux density in a certain magnetic material is 0.25 T and the area of the material is 25 mm². The magnetic flux through material is:-

[Question ID = 1639]

1. 6.25 μWb

[Option ID = 6550]

2. 2.5 μWb

[Option ID = 6551]

3. 0.5 μWb

[Option ID = 6552]

4. 25 μWb

[Option ID = 6553]

Correct Answer :-

- 6.25 μWb

[Option ID = 6550]

57) A parallel-plate capacitor is formed with a mica dielectric $\epsilon_r = 6$, a plate area of 10 mm² and a separation of 0.01 mm². If the potential difference between the lower and upper plates is 100V, the total charge stored in capacitor is:-

[Question ID = 1640]

1. 12.00 μC

[Option ID = 6554]

2. 62.46 μC

[Option ID = 6555]

3. 5.31 μC

[Option ID = 6556]

4. 10.78 μC

[Option ID = 6557]

Correct Answer :-

- 5.31 μC

[Option ID = 6556]

58) The gradient of the field $f = \rho^2 z \cos 2\phi$ at point (2, 90°, 1) is

[Question ID = 1641]

1. $-4(\hat{u}_\rho - \hat{u}_z)$

[Option ID = 6558]

2. $-4(\hat{u}_\rho + \hat{u}_z)$

[Option ID = 6559]

3. $4(\hat{u}_\rho - \hat{u}_\phi)$

[Option ID = 6560]

4. $-4(\hat{u}_\rho - \hat{u}_\phi)$

[Option ID = 6561]

Correct Answer :-

- $-4(\hat{u}_\rho + \hat{u}_z)$

[Option ID = 6559]

59) For a dielectric material in which the electric field is 100 kV/m and electric susceptibility is 4.75, the magnitude of electric flux density is

[Question ID = 1642]

1. $8.62 \mu\text{C}/\text{m}^2$
[Option ID = 6562]
2. $5.09 \mu\text{C}/\text{m}^2$
[Option ID = 6563]
3. $6.31 \mu\text{C}/\text{m}^2$
[Option ID = 6564]
4. $7.12 \mu\text{C}/\text{m}^2$
[Option ID = 6565]

Correct Answer :-

- $5.09 \mu\text{C}/\text{m}^2$
[Option ID = 6563]

60) The speed of light in a certain medium is 25% of its speed in vacuum. The relative permittivity ϵ_r of this medium with the relative permeability $\mu_r = 1$ is

[Question ID = 1643]

1. 3 [Option ID = 6566]
2. 5 [Option ID = 6567]
3. 2 [Option ID = 6568]
4. $1/2$ [Option ID = 6569]

Correct Answer :-

- 2 [Option ID = 6568]

61) In register index addressing mode the effective address is given by

[Question ID = 1644]

1. The sum of the index register value and the operand [Option ID = 6570]
2. The operand [Option ID = 6571]
3. The difference of the index register value and the operand [Option ID = 6572]
4. The index register value [Option ID = 6573]

Correct Answer :-

- The index register value [Option ID = 6573]

62) In an 8085 microprocessor, the instruction CMP B has been executed while the content of the accumulator is less than that of register B. as a result:-

[Question ID = 1645]

1. Carry flag will be reset but zero flag will be set [Option ID = 6574]
2. Carry flag will be set but zero flag will be reset [Option ID = 6575]
3. Both Carry flag and zero flag will be reset [Option ID = 6576]
4. Both Carry flag and zero flag will be set [Option ID = 6577]

Correct Answer :-

- Carry flag will be set but zero flag will be reset [Option ID = 6575]

63) A microprocessor with a 16-bit address bus is used in a linear memory selection configuration with 4 memory chips. The maximum addressable memory space is:-

[Question ID = 1646]

1. 64 k [Option ID = 6578]
2. 8 k [Option ID = 6579]
3. 4 k [Option ID = 6580]
4. 16 k [Option ID = 6581]

Correct Answer :-

- 16 k [Option ID = 6581]

64) The number of hardware interrupts (which require an external signal to interrupt) present in a 8085 microprocessor are:-

[Question ID = 1647]

1. 4 [Option ID = 6582]
2. 5 [Option ID = 6583]
3. 1 [Option ID = 6584]
4. 13 [Option ID = 6585]

Correct Answer :-

- 5 [Option ID = 6583]

65) An 8085 assembly language program is given below. Assume that the carry flag is initially unset. The content of the accumulator after the execution of the program is

`MVI A, 07H`

```
RLC
MOV B,A
RLC
RLC
ADD B
RRC
```

[Question ID = 1648]

1. 64 H [Option ID = 6586]
2. 23 H [Option ID = 6587]
3. 8C H [Option ID = 6588]
4. 15 H [Option ID = 6589]

Correct Answer :-

- 23 H [Option ID = 6587]

66) In 8085, the pairing of registers B,C,D,E,H,L is

[Question ID = 1649]

1. B-D , C-E , H-L [Option ID = 6590]
2. B-C , D-E , H-L [Option ID = 6591]
3. B-C , D-L, H-E [Option ID = 6592]
4. B-H , D-E, C-L [Option ID = 6593]

Correct Answer :-

- B-C , D-E , H-L [Option ID = 6591]

67) The initial contents of ACC and CY in 8085 are CY = 1 and ACC = 10000001 After instruction RAL is executed twice the contents of CY and ACC respectively will be

[Question ID = 1650]

1. 0 and 00000011 [Option ID = 6594]
2. 1 and 00000111 [Option ID = 6595]
3. 0 and 00000001 [Option ID = 6596]
4. 0 and 00000111 [Option ID = 6597]

Correct Answer :-

- 0 and 00000111 [Option ID = 6597]

68) When we use RRC instruction once in 8085, the number is

[Question ID = 1651]

1. multiplied by 2 [Option ID = 6598]
2. divided by 2 [Option ID = 6599]
3. Multiplied by 4 [Option ID = 6600]
4. Divided by 4 [Option ID = 6601]

Correct Answer :-

- divided by 2 [Option ID = 6599]

69) In a microprocessor

[Question ID = 1652]

1. One machine cycle consists of several clock cycles [Option ID = 6602]
2. One machine cycle is equal to one clock cycle [Option ID = 6603]
3. One clock cycle consists of several machine cycles [Option ID = 6604]
4. One machine cycle is always less than one clock cycle [Option ID = 6605]

Correct Answer :-

- One machine cycle consists of several clock cycles [Option ID = 6602]

70) In 8085

[Question ID = 1653]

1. RST 6.5 and RST 5.5 are low level sensitive interrupts [Option ID = 6606]
2. RST 5.5 is low level sensitive interrupt and RST 6.5 is high level interrupt [Option ID = 6607]
3. RST 6.5 and RST 5.5 are high level sensitive interrupts [Option ID = 6608]
4. RST 5.5 is high level sensitive interrupt and RST 6.5 is low level interrupt [Option ID = 6609]

Correct Answer :-

- RST 6.5 and RST 5.5 are high level sensitive interrupts [Option ID = 6608]

71) 11001, 1001 and 111001 correspond to the 2's complement representation of which one of the following set of numbers?

[Question ID = 1654]

1. 25,9 and 57 respectively [Option ID = 6610]

2. -6,-6 and -6 respectively [Option ID = 6611]
3. -25,-9 and -57 respectively [Option ID = 6612]
4. -7,-7 and -7 respectively [Option ID = 6613]

Correct Answer :-

- -7,-7 and -7 respectively [Option ID = 6613]

72) The Boolean expression for the truth table shown is

A	B	C	F
0	0	0	0
0	0	1	0
0	1	0	0
0	1	1	1
1	0	0	0
1	0	1	0
1	1	0	1
1	1	1	0

[Question ID = 1655]

1. $B(A + C)(\bar{A} + \bar{C})$

[Option ID = 6614]

2. $B(A + \bar{C})(\bar{A} + C)$

[Option ID = 6615]

3. $\bar{B}(A + \bar{C})(\bar{A} + C)$

[Option ID = 6616]

4. $\bar{B}(A + C)(\bar{A} + \bar{C})$

[Option ID = 6617]

Correct Answer :-

- $B(A + C)(\bar{A} + \bar{C})$

[Option ID = 6614]

73) In a J-K FF we have $J = \bar{Q}$ and $k = 1$ (see figure). Assuming the flip-flop was initially cleared and then clocked for 6 pulses, the sequence at the Q output will be

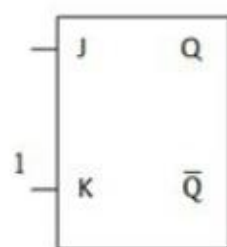

[Question ID = 1656]

1. 010000

[Option ID = 6618]

2. 011001

[Option ID = 6619]

3. 010101

[Option ID = 6620]

4. 010010

[Option ID = 6621]

Correct Answer :-

- 010101

[Option ID = 6620]

74) Among the digital IC-families - ECL, TTL and CMOS

[Question ID = 1657]

1. TTL has largest fan out [Option ID = 6622]

2. CMOS has the biggest noise margin [Option ID = 6623]

3. TTL has the lowest power consumption [Option ID = 6624]
4. ECL has the least propagation delay [Option ID = 6625]

Correct Answer :-

- ECL has the least propagation delay [Option ID = 6625]

75) Choose the correct statement from the following

[Question ID = 1658]

1. PROM contains a programmable AND array and a fixed OR array [Option ID = 6626]
2. PROM contains a fixed AND array and a programmable OR array [Option ID = 6627]
3. PLA contain a fixed AND array and a programmable OR array [Option ID = 6628]
4. PLA contains a programmable AND array and a fixed OR array [Option ID = 6629]

Correct Answer :-

- PROM contains a fixed AND array and a programmable OR array [Option ID = 6627]

76) The American Standard Code for Information Interchange has 256 characters, which are binary coded. If a certain computer generates 1,000,000 character per second, the minimum bandwidth required to transmit this signal will be

[Question ID = 1659]

1. 8 M bits/sec [Option ID = 6630]
2. 0.8 M bits/sec [Option ID = 6631]
3. 16 M bits/sec [Option ID = 6632]
4. 1.6 M bits/sec [Option ID = 6633]

Correct Answer :-

- 8 M bits/sec [Option ID = 6630]

77) If $X\bar{Y} + \bar{X}Y = Z$ then $X\bar{Z} + \bar{X}Z$ is equal to

[Question ID = 1660]

1. \bar{Y}

[Option ID = 6634]

2. Y

[Option ID = 6635]

3. 0

[Option ID = 6636]

4. 1

[Option ID = 6637]

Correct Answer :-

- Y

[Option ID = 6635]

78) In a digital system, if $(211)_x = (152)_8$, then the value of base x is

[Question ID = 1661]

1. 7 [Option ID = 6638]
2. 5 [Option ID = 6639]
3. 6 [Option ID = 6640]
4. 9 [Option ID = 6641]

Correct Answer :-

- 7 [Option ID = 6638]

79) How many AND gates are required to realize $Y = CD + EF + G$

[Question ID = 1662]

1. 3 [Option ID = 6642]
2. 4 [Option ID = 6643]
3. 2 [Option ID = 6644]
4. 5 [Option ID = 6645]

Correct Answer :-

- 2 [Option ID = 6644]

80) The analog output voltage (V_0) of 6-bit digital-to-analog converter (R-2R ladder network) with V_{ref} as 10V when the digital input is 011100 is

[Question ID = 1663]

1. 8.65 V [Option ID = 6646]
2. 4.37 V [Option ID = 6647]
3. 2.6 V [Option ID = 6648]
4. 10 V [Option ID = 6649]

Correct Answer :-

- 4.37 V [Option ID = 6647]

81) A dc supply voltage has a no load voltage of 30 V, and a full-load voltage of 25 V at a full-load current of 1 A. Its output resistance is:-

[Question ID = 1664]

1. 5 Ω [Option ID = 6650]
2. 30 Ω [Option ID = 6651]
3. 25 Ω [Option ID = 6652]
4. 20 Ω [Option ID = 6653]

Correct Answer :-

- 25 Ω [Option ID = 6652]

82) An *n*pn transistor has $f_T = 1.47 \times 10^{10}$ Hz and DC current gain $\beta_0 = 90$. For this transistor, f_β is

[Question ID = 1665]

1. 2.32×10^9 Hz [Option ID = 6654]
2. 1.64×10^8 Hz [Option ID = 6655]
3. 1.64×10^9 Hz [Option ID = 6656]
4. 2.32×10^8 Hz [Option ID = 6657]

Correct Answer :-

- 1.64×10^8 Hz [Option ID = 6655]

83) If the differential voltage gain and common mode gain of a differential amplifier are 48 dB and 2dB respectively. Then the common mode rejection ratio is:-

[Question ID = 1666]

1. 25 dB [Option ID = 6658]
2. 23 dB [Option ID = 6659]
3. 46 dB [Option ID = 6660]
4. 50 dB [Option ID = 6661]

Correct Answer :-

- 46 dB [Option ID = 6660]

84) The ripple factor from a capacitor filter _____ as the load resistance _____.

[Question ID = 1667]

1. decreases, decreases [Option ID = 6662]
2. decreases, increases [Option ID = 6663]
3. Increases, decreases [Option ID = 6664]
4. Increases, increases [Option ID = 6665]

Correct Answer :-

- decreases, increases [Option ID = 6663]

85) A feedback amplifier has an open loop gain of -100. If 4 % of the output is fed back in a degenerative loop, what is the closed loop gain of the amplifier?

[Question ID = 1668]

1. -25 [Option ID = 6666]
2. -33.3 [Option ID = 6667]
3. -20 [Option ID = 6668]
4. +25 [Option ID = 6669]

Correct Answer :-

- -20 [Option ID = 6668]

86) For $I = 250 \mu\text{A}$, $R_1 = 100 \text{ k}\Omega$, $R_2 = 70 \text{ k}\Omega$, and $R_3 = 80 \text{ k}\Omega$ in the following figure, the values for I_1 , I_2 , and V_3 are

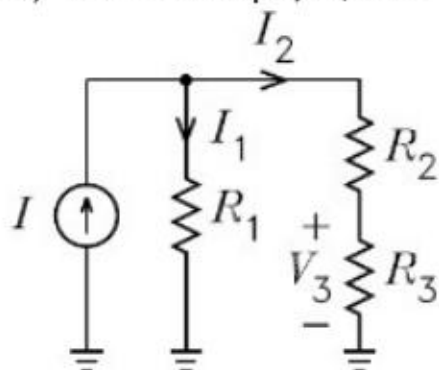

[Question ID = 1669]

1. 100 μA , 150 μA , 8V [Option ID = 6670]
2. 150 μA , 100 μA , 16V [Option ID = 6671]
3. 250 μA , 100 μA , 8V [Option ID = 6672]
4. 150 μA , 100 μA , 8V [Option ID = 6673]

Correct Answer :-

- 150 μ A, 100 μ A , 8V [Option ID = 6673]

87) Given that $R_1 = 3\text{k}\Omega$, $R_2 = 2\text{k}\Omega$, and $g_m = 0.1$ in the following figure, the input resistance to the circuit is

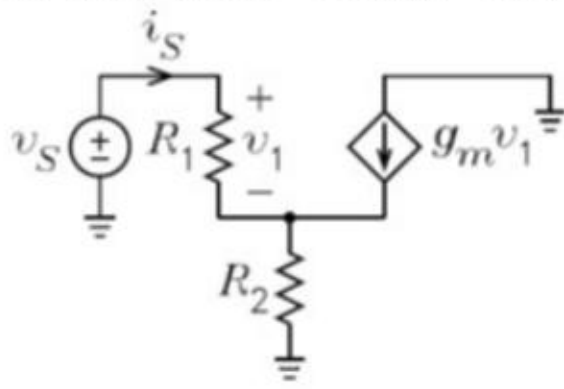

[Question ID = 1670]

1. 560 k Ω [Option ID = 6674]
2. 605 k Ω [Option ID = 6675]
3. 655 k Ω [Option ID = 6676]
4. 596 k Ω [Option ID = 6677]

Correct Answer :-

- 605 k Ω [Option ID = 6675]

88) The second harmonic distortion in an amplifier is reduced from 5% to 1% due to negative feedback. The amplifier gain is 1000, the feedback ratio will be:-

[Question ID = 1671]

1. 0.008 [Option ID = 6678]
2. 0.02 [Option ID = 6679]
3. 0.004 [Option ID = 6680]
4. 0.01 [Option ID = 6681]

Correct Answer :-

- 0.004 [Option ID = 6680]

89) A Zener regulator has an input voltage from 15 to 20 V and a load current 5 to 20 mA. If the Zener voltage is 6.8 V, the maximum value of a series resistor is:-

[Question ID = 1672]

1. 660 Ω [Option ID = 6682]
2. 320 Ω [Option ID = 6683]
3. 570 Ω [Option ID = 6684]
4. 410 Ω [Option ID = 6685]

Correct Answer :-

- 410 Ω [Option ID = 6685]

90) Two bipolar transistors Q_1 and Q_2 have the current gains $\beta_1 = 50$ and $\beta_2 = 60$, respectively. If these transistors are connected as a Darlington pair with Q_2 as output transistor and a resistance R_E of 480 Ω is connected in its emitter lead (h_{ie} is negligible). The approximate input impedance of this Darlington pair is

[Question ID = 1673]

1. 28.8 k Ω [Option ID = 6686]
2. 300 k Ω [Option ID = 6687]
3. 1.44 M Ω [Option ID = 6688]
4. 24 k Ω [Option ID = 6689]

Correct Answer :-

- 1.44 M Ω [Option ID = 6688]

91) In an amplifier with negative feedback, the bandwidth is:-

[Question ID = 1674]

1. increased by a factor of $(1 + A\beta)$

[Option ID = 6690]

2. decreased by a factor of $(1 + A\beta)$

[Option ID = 6691]

3. increased by a factor of $A\beta$

[Option ID = 6692]

4. decreased by a factor of $A\beta$

[Option ID = 6693]

Correct Answer :-

- increased by a factor of $(1 + A\beta)$

[Option ID = 6690]

92) In the circuit shown in the figure, v_s is

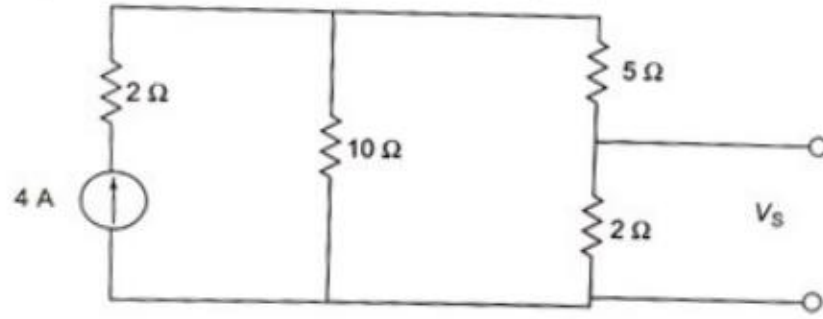

[Question ID = 1675]

1. 2.35 V [Option ID = 6694]
2. 3.5 V [Option ID = 6695]
3. 4.7 V [Option ID = 6696]
4. 6.5 V [Option ID = 6697]

Correct Answer :-

- 4.7 V [Option ID = 6696]

93) In the circuit shown in the figure, the current through the 5 Ω resistor is

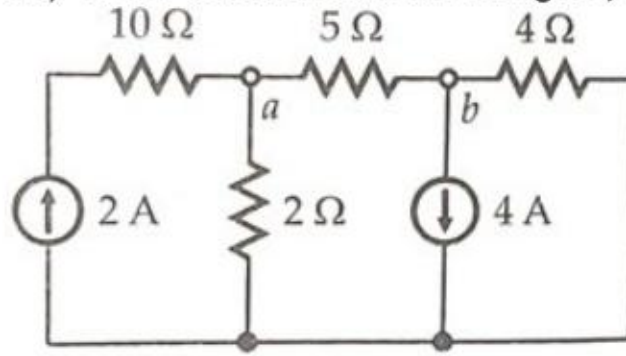

[Question ID = 1676]

1. 1.81 A [Option ID = 6698]
2. 2.96 A [Option ID = 6699]
3. 3.35 A [Option ID = 6700]
4. 4.23 A [Option ID = 6701]

Correct Answer :-

- 1.81 A [Option ID = 6698]

94) In the circuit shown in figure, the current in the 2 Ω resistor is

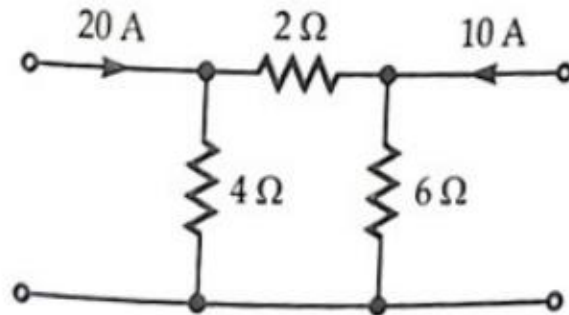

[Question ID = 1677]

1. 5.25 A [Option ID = 6702]
2. 4.75 A [Option ID = 6703]
3. 6.25 A [Option ID = 6704]
4. 11.67 A [Option ID = 6705]

Correct Answer :-

- 11.67 A [Option ID = 6705]

95) A RL series circuit has resistance 20 Ω and inductance 0.02 H. If the net impedance of the given circuit be $40\angle\phi^\circ \Omega$, the frequency is:-

[Question ID = 1678]

1. 385 Hz

[Option ID = 6706]

2. 276 Hz

[Option ID = 6707]

3. 135 Hz

[Option ID = 6708]

4. 555 Hz

[Option ID = 6709]

Correct Answer :-

- 276 Hz

[Option ID = 6707]

96) A 220 V, 110 Hz ac source supplies a series LCR circuit with a capacitor and a coil. If the coil has 50 mΩ resistance and 5 mH inductance, find the values of half power frequencies at resonance frequency of 100 Hz:-

[Question ID = 1679]

1. 89. 215 Hz, 100.725 Hz [Option ID = 6710]
2. 99. 205 Hz, 100.795 Hz [Option ID = 6711]
3. 99. 205 Hz, 110.795 Hz [Option ID = 6712]
4. 79. 235 Hz, 90.335 Hz [Option ID = 6713]

Correct Answer :-

- 99. 205 Hz, 100.795 Hz [Option ID = 6711]

97) For the given circuit, what is the value of I ?

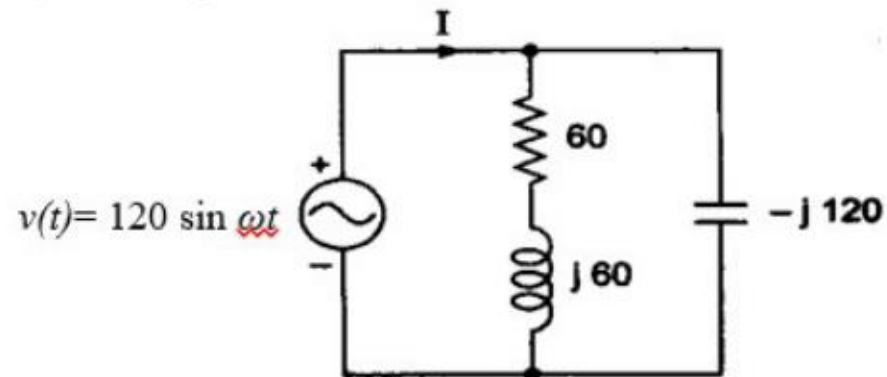

[Question ID = 1680]

1. $1 + j1$ A [Option ID = 6714]
2. $2 - j1$ A [Option ID = 6715]
3. $1 + j0$ A [Option ID = 6716]
4. $0 + j0$ A [Option ID = 6717]

Correct Answer :-

- $1 + j0$ A [Option ID = 6716]

98) Parameters for RLC circuits are $R = 2 \Omega$, $L = 1$ H and $C = 1$ F. If these are connect in parallel. The system response will be:-

[Question ID = 1681]

1. Critically damped [Option ID = 6718]
2. Overdamped [Option ID = 6719]
3. Undamped [Option ID = 6720]
4. Underdamped [Option ID = 6721]

Correct Answer :-

- Underdamped [Option ID = 6721]

99) The voltage V in Fig. is:-

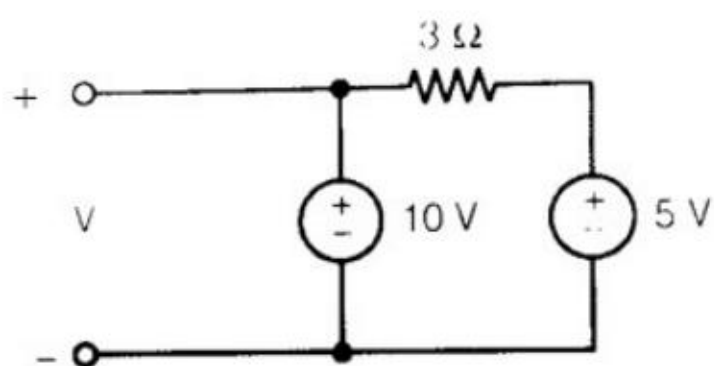

[Question ID = 1682]

1. 15 V

[Option ID = 6722]

2. 5 V

[Option ID = 6723]

3. 10 V

[Option ID = 6724]

4. None of these

[Option ID = 6725]

Correct Answer :-

- 10 V

[Option ID = 6724]

100) A parallel RLC circuit has $R = 1\text{K}\Omega$ and $C = 1\ \mu\text{F}$. The quality factor at resonance is 200. The value of inductor is:-

[Question ID = 1683]

1. $35.4\ \mu\text{H}$

[Option ID = 6726]

2. $17.7\ \mu\text{H}$

[Option ID = 6727]

3. $25\ \mu\text{H}$

[Option ID = 6728]

4. $50\ \mu\text{H}$

[Option ID = 6729]

Correct Answer :-

- $25\ \mu\text{H}$

[Option ID = 6728]