

# National Testing Agency

**Question Paper Name:** Paper I EHG 8th April 2019 Shift 1  
**Subject Name:** Paper I EHG  
**Creation Date:** 2019-04-08 14:29:50  
**Duration:** 180  
**Total Marks:** 360  
**Display Marks:** Yes

## Paper I

**Group Number :** 1  
**Group Id :** 416529153  
**Group Maximum Duration :** 0  
**Group Minimum Duration :** 180  
**Revisit allowed for view? :** No  
**Revisit allowed for edit? :** No  
**Break time:** 0  
**Group Marks:** 360

## Physics

**Section Id :** 416529253  
**Section Number :** 1  
**Section type :** Online  
**Mandatory or Optional:** Mandatory  
**Number of Questions:** 30  
**Number of Questions to be attempted:** 30  
**Section Marks:** 120  
**Display Number Panel:** Yes  
**Group All Questions:** No

**Sub-Section Number:** 1  
**Sub-Section Id:** 416529393  
**Question Shuffling Allowed :** Yes

**Question Number : 1 Question Type : MCQ Option Shuffling : Yes Display Question Number : Yes Single Line Question Option : No Option Orientation : Vertical**

**Correct Marks : 4 Wrong Marks : 1**

In SI units, the dimensions of  $\sqrt{\frac{\epsilon_0}{\mu_0}}$  is :

**Options :**

1.  $AT^2M^{-1}L^{-1}$

2.  $A^2T^3M^{-1}L^{-2}$

3.  $A^{-1}TML^3$

4.  $AT^{-3}ML^{3/2}$

Question Number : 1 Question Type : MCQ Option Shuffling : Yes Display Question Number : Yes Single Line Question Option : No Option Orientation : Vertical

Correct Marks : 4 Wrong Marks : 1

SI इकाई में,  $\sqrt{\frac{\epsilon_0}{\mu_0}}$  की विमा है :

Options :

1.  $AT^2M^{-1}L^{-1}$

2.  $A^2T^3M^{-1}L^{-2}$

3.  $A^{-1}TML^3$

4.  $AT^{-3}ML^{3/2}$

Question Number : 1 Question Type : MCQ Option Shuffling : Yes Display Question Number : Yes Single Line Question Option : No Option Orientation : Vertical

Correct Marks : 4 Wrong Marks : 1

SI એકમ પદ્ધતીમાં,  $\sqrt{\frac{\epsilon_0}{\mu_0}}$  નું પરિમાણ \_\_\_\_\_

છે.

Options :

1.  $AT^2M^{-1}L^{-1}$

2.  $A^2T^3M^{-1}L^{-2}$

3.  $A^{-1}TML^3$

4.  $AT^{-3}ML^{3/2}$

Question Number : 2 Question Type : MCQ Option Shuffling : Yes Display Question Number : Yes Single Line Question Option : No Option Orientation : Vertical

Correct Marks : 4 Wrong Marks : 1

Ship A is sailing towards north-east with velocity  $\vec{v} = 30\hat{i} + 50\hat{j}$  km/hr where  $\hat{i}$  points east and  $\hat{j}$ , north. Ship B is at a distance of 80 km east and 150 km north of Ship A and is sailing towards west at 10 km/hr. A will be at minimum distance from B in :

Options :

1. 4.2 hrs.
2. 2.2 hrs.
3. 2.6 hrs.
4. 3.2 hrs.

Question Number : 2 Question Type : MCQ Option Shuffling : Yes Display Question Number : Yes Single Line Question Option : No Option Orientation : Vertical

Correct Marks : 4 Wrong Marks : 1

जहाज A वेग  $\vec{v} = 30\hat{i} + 50\hat{j}$  km/hr से उत्तर-पूर्व

दिशा में जलयात्रा कर रहा है जहाँ  $\hat{i}$  पूर्व तथा  $\hat{j}$  उत्तर की ओर इंगित हैं। जहाज B, जहाज A से 80 km पूर्व की ओर और 150 km उत्तर की ओर, दूरी पर स्थित है और पश्चिम की ओर 10 km/hr की चाल से जलयात्रा कर रहा है। A से B की दूरी न्यूनतम होगी :

Options :

1. 4.2 घंटे में
2. 2.2 घंटे में
3. 2.6 घंटे में
4. 3.2 घंटे में

Question Number : 2 Question Type : MCQ Option Shuffling : Yes Display Question Number : Yes Single Line Question Option : No Option Orientation : Vertical

Correct Marks : 4 Wrong Marks : 1

$\vec{v} = 30\hat{i} + 50\hat{j}$  km/hr ના વેગથી એક વહાણ A

ઉત્તર-પૂર્વ દિશા તરફ જઈ રહ્યું છે. અહીં  $\hat{i}$  એ પૂર્વ તરફ અને  $\hat{j}$  એ ઉત્તર દિશા દર્શાવે છે. વહાણ B એ વહાણ A થી પૂર્વ દિશામાં 80 km અને ઉત્તર દિશામાં 150 km એ છે. અને તે પશ્ચિમ તરફ 10 km/hr ના વેગ થી જાય છે. A એ B થી \_\_\_\_\_ સમયમાં લઘુત્તમ અંતરે હશે.

Options :

1. 4.2 કલાક
2. 2.2 કલાક
3. 2.6 કલાક
4. 3.2 કલાક

Question Number : 3 Question Type : MCQ Option Shuffling : Yes Display Question Number : Yes Single Line Question Option : No Option Orientation : Vertical

Correct Marks : 4 Wrong Marks : 1

Four particles A, B, C and D with masses  $m_A = m$ ,  $m_B = 2m$ ,  $m_C = 3m$  and  $m_D = 4m$  are at the corners of a square. They have accelerations of equal magnitude with directions as shown. The acceleration of the centre of mass of the particles is :

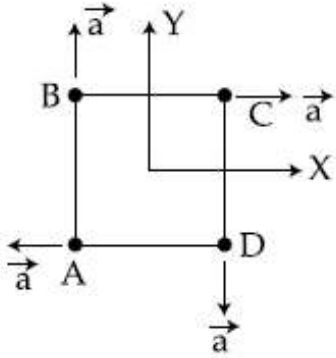

Options :

1. Zero
2.  $a(\hat{i} + \hat{j})$
3.  $\frac{a}{5}(\hat{i} + \hat{j})$

4.  $\frac{a}{5}(\hat{i}-\hat{j})$

Question Number : 3 Question Type : MCQ Option Shuffling : Yes Display Question Number : Yes Single Line Question Option : No Option Orientation : Vertical

Correct Marks : 4 Wrong Marks : 1

द्रव्यमान  $m_A = m$ ,  $m_B = 2m$ ,  $m_C = 3m$  और  $m_D = 4m$  वाले चार कण A, B, C और D एक वर्ग के कोनों पर रखे गये हैं। उनके त्वरण एकसमान परिमाण के हैं और दर्शाए गये चित्र के अनुसार हैं। कणों के द्रव्यमान केन्द्र का त्वरण है :

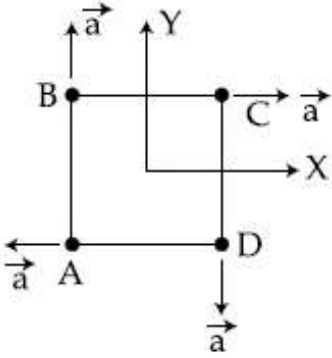

Options :

1. शून्य
2.  $a(\hat{i}+\hat{j})$
3.  $\frac{a}{5}(\hat{i}+\hat{j})$
4.  $\frac{a}{5}(\hat{i}-\hat{j})$

Question Number : 3 Question Type : MCQ Option Shuffling : Yes Display Question Number : Yes Single Line Question Option : No Option Orientation : Vertical

Correct Marks : 4 Wrong Marks : 1

ચાર કણો A, B, C અને D ના દળો અનુક્રમે  $m_A = m$ ,  $m_B = 2m$ ,  $m_C = 3m$  અને  $m_D = 4m$  છે જેઓને ચોરસના ખૂણા ઉપર મૂકવામાં આવ્યા છે. આકૃતિમાં બતાવ્યા પ્રમાણેની દિશામાં તેઓના પ્રવેગનું મૂલ્ય એકસમાન છે. કણોના દ્રવ્યમાન કેન્દ્રનો પ્રવેગ \_\_\_\_\_ છે.

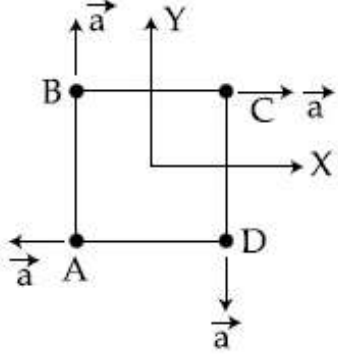

Options :

1. શૂન્ય
2.  $a(\hat{i} + \hat{j})$
3.  $\frac{a}{5}(\hat{i} + \hat{j})$
4.  $\frac{a}{5}(\hat{i} - \hat{j})$

Question Number : 4 Question Type : MCQ Option Shuffling : Yes Display Question Number : Yes Single Line Question Option : No Option Orientation : Vertical

Correct Marks : 4 Wrong Marks : 1

A particle moves in one dimension from rest under the influence of a force that varies with the distance travelled by the particle as shown in the figure. The kinetic energy of the particle after it has travelled 3 m is :

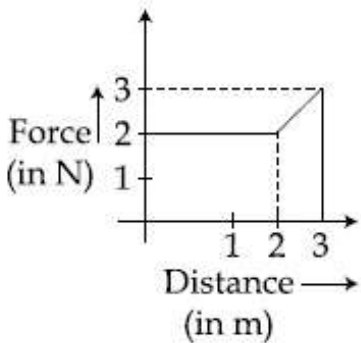

Options :

1. 5 J
2. 6.5 J
3. 4 J
4. 2.5 J

Question Number : 4 Question Type : MCQ Option Shuffling : Yes Display Question Number : Yes Single Line Question Option : No Option Orientation : Vertical

Correct Marks : 4 Wrong Marks : 1

एक कण एक बल के प्रभाव में विराम अवस्था से गति प्रारम्भ करता है। बल, कण द्वारा चली दूरी के अनुसार इस प्रकार परिवर्तित होता है जैसा कि चित्र में दर्शाया गया है। 3 m दूरी चलने के बाद कण की गतिज ऊर्जा है :

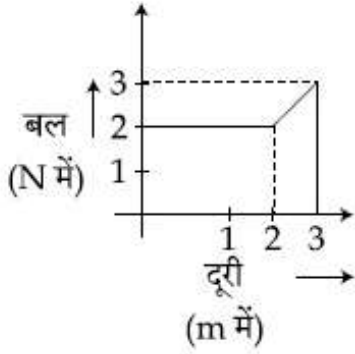

Options :

1. 5 J
2. 6.5 J
3. 4 J
4. 2.5 J

Question Number : 4 Question Type : MCQ Option Shuffling : Yes Display Question Number : Yes Single Line Question Option : No Option Orientation : Vertical

Correct Marks : 4 Wrong Marks : 1



આકૃતિમાં બતાવ્યા પ્રમાણે એક કણ તેની સ્થિર સ્થિતિમાંથી કોઈ બળ ની અસર હેઠળ ગતિ કરવાનું શરૂ કરે છે. અહીં આ બળ એ કણ દ્વારા કાપવામાં આવેલા અંતર સાથે બદલાય છે. 3 m અંતર કાપ્યા પછી કણની ગતિઊર્જા \_\_\_\_\_ છે.

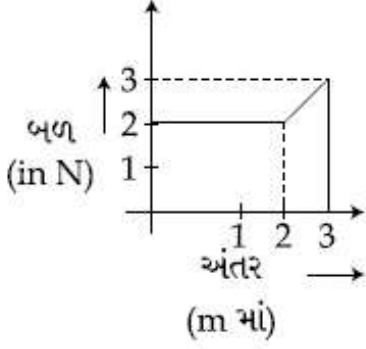

Options :

1. 5 J
2. 6.5 J
3. 4 J
4. 2.5 J

Question Number : 5 Question Type : MCQ Option Shuffling : Yes Display Question Number : Yes Single Line Question Option : No Option Orientation : Vertical

Correct Marks : 4 Wrong Marks : 1

A thin circular plate of mass  $M$  and radius  $R$  has its density varying as  $\rho(r) = \rho_0 r$  with  $\rho_0$  as constant and  $r$  is the distance from its center. The moment of Inertia of the circular plate about an axis perpendicular to the plate and passing through its edge is  $I = a MR^2$ . The value of the coefficient  $a$  is :

Options :

1.  $\frac{8}{5}$
2.  $\frac{3}{2}$
3.  $\frac{3}{5}$
4.  $\frac{1}{2}$



Question Number : 5 Question Type : MCQ Option Shuffling : Yes Display Question Number : Yes Single Line Question Option : No Option Orientation : Vertical

Correct Marks : 4 Wrong Marks : 1

द्रव्यमान  $M$  और त्रिज्या  $R$  की एक वृत्तीय प्लेट का घनत्व  $\rho(r) = \rho_0 r$ , के अनुसार परिवर्तित हो रहा है जहाँ  $\rho_0$  स्थिरांक है और  $r$  उसके केन्द्र से दूरी है। प्लेट के लम्बवत् और प्लेट की परिधि से जाने वाली अक्ष के परितः वृत्तीय प्लेट का जड़त्व आघूर्ण  $I = a MR^2$  है। गुणांक  $a$  का मान है :

Options :

1.  $\frac{8}{5}$

2.  $\frac{3}{2}$

3.  $\frac{3}{5}$

4.  $\frac{1}{2}$

Question Number : 5 Question Type : MCQ Option Shuffling : Yes Display Question Number : Yes Single Line Question Option : No Option Orientation : Vertical

Correct Marks : 4 Wrong Marks : 1

$M$  દળ અને  $R$  ત્રિજ્યાવાળી એક પાતળી વર્તુળાકાર તકતીની ઘનતા માટે  $\rho(r) = \rho_0 r$  અનુસાર બદલાય છે, જ્યાં  $\rho_0$  અચળ અને  $r$  એ કેન્દ્રથી અંતર છે. તકતીને લંબ હોય અને તકતીની ધારને કાપતી (સ્પર્શતી) હોય એવી અક્ષને સાપેક્ષે વર્તુળાકાર તકતીની જડત્વની ચાકમાત્રા  $I = a MR^2$  છે. તો ગુણક  $a$  નું મૂલ્ય \_\_\_\_\_ છે.

Options :

1.  $\frac{8}{5}$

2.  $\frac{3}{2}$

3.  $\frac{3}{5}$

4.  $\frac{1}{2}$

Question Number : 6 Question Type : MCQ Option Shuffling : Yes Display Question Number : Yes Single Line Question Option : No Option Orientation : Vertical

Correct Marks : 4 Wrong Marks : 1

Four identical particles of mass  $M$  are located at the corners of a square of side 'a'. What should be their speed if each of them revolves under the influence of others' gravitational field in a circular orbit circumscribing the square ?

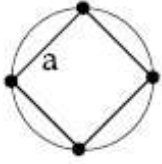

Options :

1.  $1.21 \sqrt{\frac{GM}{a}}$

2.  $1.35 \sqrt{\frac{GM}{a}}$

3.  $1.41 \sqrt{\frac{GM}{a}}$

4.  $1.16 \sqrt{\frac{GM}{a}}$

Question Number : 6 Question Type : MCQ Option Shuffling : Yes Display Question Number : Yes Single Line Question Option : No Option Orientation : Vertical

Correct Marks : 4 Wrong Marks : 1

द्रव्यमान  $M$  के चार एकसमान कण भुजा 'a' के एक वर्ग के कोनों पर स्थित हैं। यदि ये कण एक दूसरे के गुरुत्वाकर्षण प्रभाव में इस वर्ग के परिवृत्त एक वृत्तीय कक्षा में गतिशील हैं तो कण की चाल क्या होगी ?

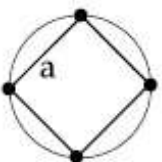

Options :

1.  $1.21 \sqrt{\frac{GM}{a}}$

2.  $1.35 \sqrt{\frac{GM}{a}}$

3.  $1.41 \sqrt{\frac{GM}{a}}$

4.  $1.16 \sqrt{\frac{GM}{a}}$

Question Number : 6 Question Type : MCQ Option Shuffling : Yes Display Question Number : Yes Single Line Question Option : No Option Orientation : Vertical

Correct Marks : 4 Wrong Marks : 1

'a' બાજુવાળા એક ચોરસના ખૂણાઓ પર M દળવાળા ચાર સમાન કણોને મૂકવામાં આવેલા છે. જો તેઓ એક બીજાના ગુરૂત્વાકર્ષી ક્ષેત્રની અસર હેઠળ ચોરસને બહારથી સ્પર્શતી વર્તુળાકાર કક્ષામાં ભ્રમણ કરતા હોય તો તેમની ઝડપ શોધો.

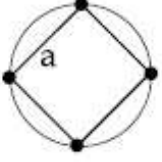

Options :

1.  $1.21 \sqrt{\frac{GM}{a}}$

2.  $1.35 \sqrt{\frac{GM}{a}}$

3.  $1.41 \sqrt{\frac{GM}{a}}$

4.  $1.16 \sqrt{\frac{GM}{a}}$

Question Number : 7 Question Type : MCQ Option Shuffling : Yes Display Question Number : Yes Single Line Question Option : No Option Orientation : Vertical

Correct Marks : 4 Wrong Marks : 1

A boy's catapult is made of rubber cord which is 42 cm long, with 6 mm diameter of cross-section and of negligible mass. The boy keeps a stone weighing 0.02 kg on it and stretches the cord by 20 cm by applying a constant force. When released, the stone flies off with a velocity of  $20 \text{ ms}^{-1}$ . Neglect the change in the area of cross-section of the cord while stretched. The Young's modulus of rubber is closest to :

Options :

1.  $10^6 \text{ Nm}^{-2}$
2.  $10^8 \text{ Nm}^{-2}$
3.  $10^4 \text{ Nm}^{-2}$
4.  $10^3 \text{ Nm}^{-2}$

Question Number : 7 Question Type : MCQ Option Shuffling : Yes Display Question Number : Yes Single Line Question Option : No Option Orientation : Vertical

Correct Marks : 4 Wrong Marks : 1

एक बालक का गुलेल 42 cm लम्बी और 6 mm अनुप्रस्थ काट के व्यास की रबड़ की डोरी का बना है, जिसका द्रव्यमान नगण्य है। बालक 0.02 kg भार का एक पत्थर इस पर रखता है और डोरी को एक नियत बल से 20 cm द्वारा तानित करता है। जब इसे छोड़ता है, तब पत्थर  $20 \text{ ms}^{-1}$  के वेग से जाता है। तानित होने पर डोरी के अनुप्रस्थ काट में परिवर्तन नगण्य है। रबड़ का यंग प्रत्यास्थता गुणांक का निकटतम मान है :

Options :

1.  $10^6 \text{ Nm}^{-2}$
2.  $10^8 \text{ Nm}^{-2}$
3.  $10^4 \text{ Nm}^{-2}$
4.  $10^3 \text{ Nm}^{-2}$

Question Number : 7 Question Type : MCQ Option Shuffling : Yes Display Question Number : Yes Single Line Question Option : No Option Orientation : Vertical

Correct Marks : 4 Wrong Marks : 1

42 cm લાંબી અને 6 mm વ્યાસવાળી એક રબ્બરની પટ્ટી માંથી એક છોકરા માટે ગીલોલ બનાવવામાં આવે છે. છોકરો 0.02 kg વજન વાળા પથ્થરને ગીલોલ પર મૂકે છે અને પટ્ટીને 20 cm જેટલી ખેંચે છે. જ્યારે તેને છોડવામાં આવે છે ત્યારે પથ્થર  $20 \text{ ms}^{-1}$  ના વેગથી ફેંકાય છે. અહીં જ્યારે પટ્ટીને ખેંચવામાં આવે છે ત્યારે એના આડછેદને અવગણવામાં આવે છે. તો રબ્બરનો યંગ મોડ્યુલસ \_\_\_\_\_ ની નજીક છે.

Options :

1.  $10^6 \text{ Nm}^{-2}$
2.  $10^8 \text{ Nm}^{-2}$
3.  $10^4 \text{ Nm}^{-2}$
4.  $10^3 \text{ Nm}^{-2}$

Question Number : 8 Question Type : MCQ Option Shuffling : Yes Display Question Number : Yes Single Line Question Option : No Option Orientation : Vertical

Correct Marks : 4 Wrong Marks : 1

Water from a pipe is coming at a rate of 100 liters per minute. If the radius of the pipe is 5 cm, the Reynolds number for the flow is of the order of : (density of water =  $1000 \text{ kg/m}^3$ , coefficient of viscosity of water =  $1 \text{ mPa s}$ )

Options :

1.  $10^4$
2.  $10^3$
3.  $10^6$
4.  $10^2$

Question Number : 8 Question Type : MCQ Option Shuffling : Yes Display Question Number : Yes Single Line Question Option : No Option Orientation : Vertical

Correct Marks : 4 Wrong Marks : 1

एक पाइप से पानी 100 लीटर प्रति मिनट की दर से निकल रहा है। यदि पाइप की त्रिज्या 5 cm है, तब प्रवाह की रेनॉल्ड संख्या की कोटि है : (पानी का घनत्व =  $1000 \text{ kg/m}^3$ , पानी का श्यानता गुणांक =  $1 \text{ mPa s}$ )

Options :

1.  $10^4$
2.  $10^3$
3.  $10^6$
4.  $10^2$

Question Number : 8 Question Type : MCQ Option Shuffling : Yes Display Question Number : Yes Single Line Question Option : No Option Orientation : Vertical

Correct Marks : 4 Wrong Marks : 1

ફાયર બ્રીગેડના પાઈપમાંથી 100 લિટર/મીનિટ ના દરથી પાણી આવે છે. જો પાઈપની ત્રિજ્યા 5 cm હોય તો પ્રવાહનો રેનોલ્ડ નંબર \_\_\_\_\_ ના ક્રમનો છે. (પાણીની ઘનતા =  $1000 \text{ kg/m}^3$ , પાણીનો સિન્ગધતા અંક =  $1 \text{ mPa s}$ )

Options :

1.  $10^4$
2.  $10^3$
3.  $10^6$
4.  $10^2$

Question Number : 9 Question Type : MCQ Option Shuffling : Yes Display Question Number : Yes Single Line Question Option : No Option Orientation : Vertical

Correct Marks : 4 Wrong Marks : 1



Two identical beakers A and B contain equal volumes of two different liquids at  $60^{\circ}\text{C}$  each and left to cool down. Liquid in A has density of  $8 \times 10^2 \text{ kg/m}^3$  and specific heat of  $2000 \text{ J kg}^{-1} \text{ K}^{-1}$  while liquid in B has density of  $10^3 \text{ kg m}^{-3}$  and specific heat of  $4000 \text{ J kg}^{-1} \text{ K}^{-1}$ . Which of the following best describes their temperature versus time graph schematically ? (assume the emissivity of both the beakers to be the same)

Options :

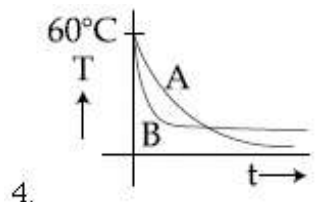
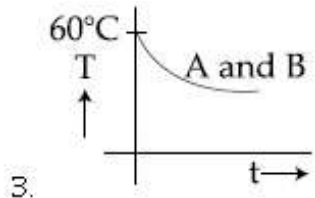
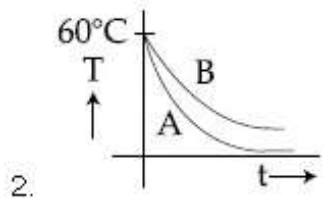
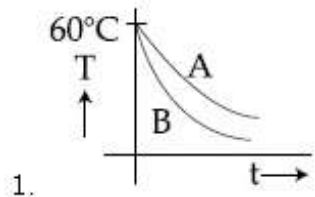

Question Number : 9 Question Type : MCQ Option Shuffling : Yes Display Question Number : Yes Single Line Question Option : No Option Orientation : Vertical Correct Marks : 4 Wrong Marks : 1



દો એકસમાન બીકર A એવં B મેં દો ભિન્ન દ્રવોં કે સમાન આયતન  $60^{\circ}\text{C}$  તાપમાન પર રખે હેં ઓર ઠંડા હોને કે લિએ છોડ દિએ ગયે હેં. A મેં દ્રવ કા ઘનત્વ  $8 \times 10^2 \text{ kg/m}^3$  હે ઓર વિશિષ્ટ ઊષ્મા  $2000 \text{ J kg}^{-1} \text{ K}^{-1}$  જબકિ B મેં દ્રવ કા ઘનત્વ  $10^3 \text{ kg m}^{-3}$  હે ઓર વિશિષ્ટ ઊષ્મા  $4000 \text{ J kg}^{-1} \text{ K}^{-1}$  હે. નિમ્નલિખિત મેં સે કોન-સા ગ્રાફ તાપમાન કા સમય કે સાથ પરિવર્તન વિધિવત્ પ્રદર્શિત કરતા હે? (દોનોં બીકરોં કી ઉત્સર્જકતા એકસમાન માન લેં)

Options :

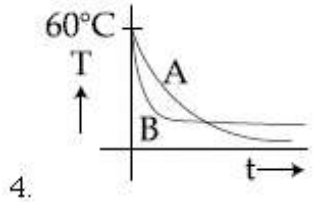
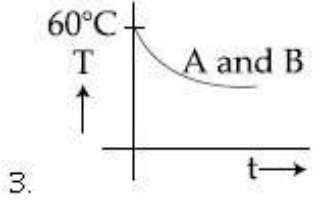
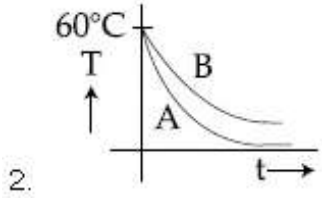
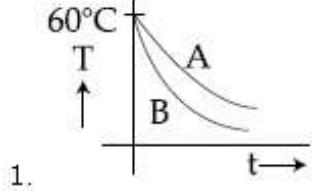

Question Number : 9 Question Type : MCQ Option Shuffling : Yes Display Question Number : Yes Single Line Question Option : No Option Orientation : Vertical

Correct Marks : 4 Wrong Marks : 1

બે એકસરખા બીકર A અને B સમાન કદવાળા બે જુદા-જુદા પ્રવાહી ને દરેક  $60^{\circ}\text{C}$  તાપમાને ઠંડા થવા મૂકવામાં આવેલા છે. બીકર A માંના પ્રવાહીની ઘનતા  $8 \times 10^2 \text{ kg/m}^3$  અને વિશિષ્ટ ઉષ્મા  $2000 \text{ J kg}^{-1} \text{ K}^{-1}$  છે જ્યારે બીકર B માંના પ્રવાહીની ઘનતા  $10^3 \text{ kg m}^{-3}$  અને વિશિષ્ટ ઉષ્મા  $4000 \text{ J kg}^{-1} \text{ K}^{-1}$  છે. નીચેનામાંથી તેમની તાપમાન વિક્ષેપ સમયની કઈ રેખાકૃતિ યોગ્ય વર્ણન કરે છે? (અહીં એવું ધારી લો કે તેમની ઉત્સર્જકતા એક સરખી છે.)

Options :

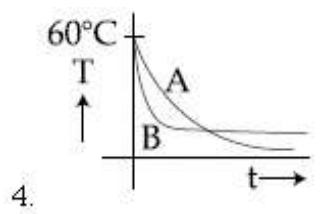
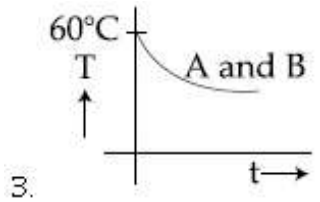
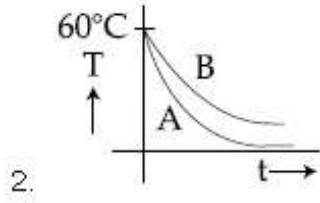
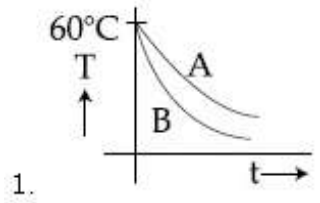

Question Number : 10 Question Type : MCQ Option Shuffling : Yes Display Question Number : Yes Single Line Question Option : No Option Orientation : Vertical  
 Correct Marks : 4 Wrong Marks : 1

A thermally insulated vessel contains 150 g of water at 0°C. Then the air from the vessel is pumped out adiabatically. A fraction of water turns into ice and the rest evaporates at 0°C itself. The mass of evaporated water will be closest to :

(Latent heat of vaporization of water =  $2.10 \times 10^6 \text{ J kg}^{-1}$  and Latent heat of Fusion of water =  $3.36 \times 10^5 \text{ J kg}^{-1}$ )

Options :

1. 150 g
2. 20 g
3. 35 g
4. 130 g

Correct Marks : 4 Wrong Marks : 1

0°C पर 150 g पानी को ऊष्मीय विलग पात्र में रखा गया है। पात्र से वायु को रूद्धोष्म प्रक्रम द्वारा निष्कासित करते हैं। पानी का एक भाग बर्फ में तथा शेष 0°C की वाष्प में परिवर्तित हो जाता है। वाष्पित पानी के द्रव्यमान का निकटतम मान होगा :

(पानी के वाष्पीकरण की गुप्त ऊष्मा =  $2.10 \times 10^6 \text{ J kg}^{-1}$  और पानी के गलन की गुप्त ऊष्मा =  $3.36 \times 10^5 \text{ J kg}^{-1}$ )

Options :

1. 150 g
2. 20 g
3. 35 g
4. 130 g

Question Number : 10 Question Type : MCQ Option Shuffling : Yes Display Question Number : Yes Single Line Question Option : No Option Orientation : Vertical

Correct Marks : 4 Wrong Marks : 1

એક ઉષ્મા અવાહક પાત્ર 0°C એ 150 g પાણી ધરાવે છે. ત્યારબાદ સમોષ્મી રીતે પાત્રમાંથી હવાને ખેંચી લેવામાં આવે છે. થોડું પાણી બરફમાં ફેરવાય છે અને બાકીના પાણીનું 0°C એ બાષ્પીભવન થઈ જાય છે. બાષ્પીભવન થયેલા પાણીનું દળ ગણો. (પાણીના વરાળની ગલન ગુપ્ત ઉષ્મા =  $2.10 \times 10^6 \text{ J kg}^{-1}$  અને ઘનીકરણ પામતા પાણીની ગલન ગુપ્ત ઉષ્મા =  $3.36 \times 10^5 \text{ J kg}^{-1}$ )

Options :

1. 150 g
2. 20 g
3. 35 g
4. 130 g

Question Number : 11 Question Type : MCQ Option Shuffling : Yes Display Question Number : Yes Single Line Question Option : No Option Orientation : Vertical

Correct Marks : 4 Wrong Marks : 1

If  $10^{22}$  gas molecules each of mass  $10^{-26}$  kg collide with a surface (perpendicular to it) elastically per second over an area  $1 \text{ m}^2$  with a speed  $10^4 \text{ m/s}$ , the pressure exerted by the gas molecules will be of the order of :

Options :

1.  $10^3 \text{ N/m}^2$
2.  $10^4 \text{ N/m}^2$
3.  $10^8 \text{ N/m}^2$
4.  $10^{16} \text{ N/m}^2$

Question Number : 11 Question Type : MCQ Option Shuffling : Yes Display Question Number : Yes Single Line Question Option : No Option Orientation : Vertical

Correct Marks : 4 Wrong Marks : 1

यदि प्रत्येक द्रव्यमान  $10^{-26} \text{ kg}$  के  $10^{22}$  गैस अणु  $10^4 \text{ m/s}$  की चाल से  $1 \text{ m}^2$  क्षेत्रफल पर प्रति सेकण्ड प्रत्यास्थ संघट्ट कर रहे हैं, तब गैस अणुओं द्वारा लगाया गया दाब का कोटिमान होगा :

Options :

1.  $10^3 \text{ N/m}^2$
2.  $10^4 \text{ N/m}^2$
3.  $10^8 \text{ N/m}^2$
4.  $10^{16} \text{ N/m}^2$

Question Number : 11 Question Type : MCQ Option Shuffling : Yes Display Question Number : Yes Single Line Question Option : No Option Orientation : Vertical

Correct Marks : 4 Wrong Marks : 1

ज्यारे  $1 \text{ m}^2$  क्षेत्रफलमा  $10^4 \text{ m/s}$  नी ङडे  $10^{-26} \text{ kg}$  दण धरावता  $10^{22}$  वायुना अणुओ प्रति सेकन्डे स्थितिस्थापक रीते अथडाता होय त्यारे आ वायुना  $1 \text{ m}^2$  क्षेत्रफल पर  $10^4 \text{ m/s}$  ङडपथी अणुओ द्वारा लागतुं दबाण \_\_\_\_\_ नां कभनुं लशे.

Options :

1.  $10^3 \text{ N/m}^2$

2.  $10^4 \text{ N/m}^2$

3.  $10^8 \text{ N/m}^2$

4.  $10^{16} \text{ N/m}^2$

Question Number : 12 Question Type : MCQ Option Shuffling : Yes Display Question Number : Yes Single Line Question Option : No Option Orientation : Vertical

Correct Marks : 4 Wrong Marks : 1

A steel wire having a radius of 2.0 mm, carrying a load of 4 kg, is hanging from a ceiling. Given that  $g = 3.1 \pi \text{ ms}^{-2}$ , what will be the tensile stress that would be developed in the wire ?

Options :

1.  $5.2 \times 10^6 \text{ Nm}^{-2}$

2.  $3.1 \times 10^6 \text{ Nm}^{-2}$

3.  $6.2 \times 10^6 \text{ Nm}^{-2}$

4.  $4.8 \times 10^6 \text{ Nm}^{-2}$

Question Number : 12 Question Type : MCQ Option Shuffling : Yes Display Question Number : Yes Single Line Question Option : No Option Orientation : Vertical

Correct Marks : 4 Wrong Marks : 1

4 kg के भार को वहन करते हुए एक 2.0 mm त्रिज्या के स्टील के एक तार को छत से लटकाया गया है। दिया है  $g = 3.1 \pi \text{ ms}^{-2}$ । तार में उत्पन्न तन्व्य प्रतिबल (tensile stress) का मान क्या होगा ?

Options :

1.  $5.2 \times 10^6 \text{ Nm}^{-2}$

2.  $3.1 \times 10^6 \text{ Nm}^{-2}$

3.  $6.2 \times 10^6 \text{ Nm}^{-2}$

4.  $4.8 \times 10^6 \text{ Nm}^{-2}$



Question Number : 12 Question Type : MCQ Option Shuffling : Yes Display Question Number : Yes Single Line Question Option : No Option Orientation : Vertical

Correct Marks : 4 Wrong Marks : 1

છત પરથી 2.0 mm ત્રિજ્યાવાળા એક સ્ટીલના તારને 4 kg વજન વડે લટકાવેલ છે. અહીં  $g = 3.1 \pi \text{ ms}^{-2}$  છે. તારમાં ઉત્પન્ન થતું તણાવ પ્રતિબળ (tensile stress) કેટલું હશે?

Options :

1.  $5.2 \times 10^6 \text{ Nm}^{-2}$
2.  $3.1 \times 10^6 \text{ Nm}^{-2}$
3.  $6.2 \times 10^6 \text{ Nm}^{-2}$
4.  $4.8 \times 10^6 \text{ Nm}^{-2}$

Question Number : 13 Question Type : MCQ Option Shuffling : Yes Display Question Number : Yes Single Line Question Option : No Option Orientation : Vertical

Correct Marks : 4 Wrong Marks : 1

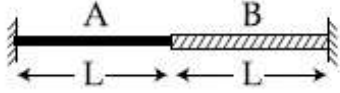

A wire of length  $2L$ , is made by joining two wires A and B of same length but different radii  $r$  and  $2r$  and made of the same material. It is vibrating at a frequency such that the joint of the two wires forms a node. If the number of antinodes in wire A is  $p$  and that in B is  $q$  then the ratio  $p : q$  is :

Options :

1. 1 : 2
2. 3 : 5
3. 4 : 9
4. 1 : 4

Question Number : 13 Question Type : MCQ Option Shuffling : Yes Display Question Number : Yes Single Line Question Option : No Option Orientation : Vertical

Correct Marks : 4 Wrong Marks : 1

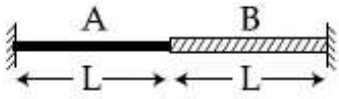

एक ही पदार्थ के एकसमान लम्बाई परन्तु भिन्न त्रिज्या  $r$  तथा  $2r$  के दो तारों को जोड़कर,  $2L$  लम्बाई का एक तार बनाया जाता है। यह इस प्रकार कम्पित होता है कि दोनों तारों का जोड़ एक निस्पंद बने। यदि तार A में प्रस्पंदों की संख्या  $p$  है और B में  $q$  है, तब अनुपात  $p : q$  है :

Options :

1. 1 : 2
2. 3 : 5
3. 4 : 9
4. 1 : 4

Question Number : 13 Question Type : MCQ Option Shuffling : Yes Display Question Number : Yes Single Line Question Option : No Option Orientation : Vertical

Correct Marks : 4 Wrong Marks : 1

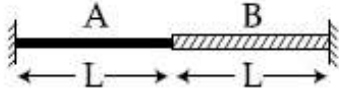

એક જ દ્રવ્યમાંથી બનાવેલા એક સરખી લંબાઈના પરંતુ જુદી જુદી ત્રિજ્યા  $r$  અને  $2r$  ધરાવતા બે તાર A અને B ને એવી રીતે જોડવામાં આવે છે કે તારની લંબાઈ  $2L$  બને છે. તે એ આવૃત્તીથી કંપન કરે છે કે જેથી બે તારના સાંધા પર નિસ્પંદ રચાય છે. જો તાર A માં પ્રસ્પંદની સંખ્યા  $p$  હોય અને તાર B માં તે  $q$  હોય તો ગુણોત્તર  $p : q$  \_\_\_\_\_ છે.

Options :

1. 1 : 2
2. 3 : 5
3. 4 : 9
4. 1 : 4

Question Number : 14 Question Type : MCQ Option Shuffling : Yes Display Question Number : Yes Single Line Question Option : No Option Orientation : Vertical

Correct Marks : 4 Wrong Marks : 1



The bob of a simple pendulum has mass 2 g and a charge of  $5.0 \mu\text{C}$ . It is at rest in a uniform horizontal electric field of intensity 2000 V/m. At equilibrium, the angle that the pendulum makes with the vertical is :

(take  $g = 10 \text{ m/s}^2$ )

Options :

1.  $\tan^{-1}(0.5)$
2.  $\tan^{-1}(5.0)$
3.  $\tan^{-1}(2.0)$
4.  $\tan^{-1}(0.2)$

Question Number : 14 Question Type : MCQ Option Shuffling : Yes Display Question Number : Yes Single Line Question Option : No Option Orientation : Vertical

Correct Marks : 4 Wrong Marks : 1

$5.0 \mu\text{C}$  आवेश वाला और द्रव्यमान 2 g का एक सरल दोलक का बॉब तीव्रता 2000 V/m के एक एकसमान क्षैतिज विद्युत क्षेत्र में विराम अवस्था पर है। साम्यावस्था में, ऊर्ध्वाधर से दोलक जो कोण बनाएगा, वह है :

( $g = 10 \text{ m/s}^2$  लें)

Options :

1.  $\tan^{-1}(0.5)$
2.  $\tan^{-1}(5.0)$
3.  $\tan^{-1}(2.0)$
4.  $\tan^{-1}(0.2)$

Question Number : 14 Question Type : MCQ Option Shuffling : Yes Display Question Number : Yes Single Line Question Option : No Option Orientation : Vertical

Correct Marks : 4 Wrong Marks : 1

2000 V/m तीव्रतावाળા એકસમાન સમક્ષિતિજ વિદ્યુત ક્ષેત્રમાં 2 g દળ અને  $5.0 \mu\text{C}$  વીજભાર વાળા એક લોલકના દોલકને સ્થિર અવસ્થામાં રાખવામાં આવેલો છે. તો ઉર્ધ્વદિશા જોડે બનતો ખૂણો \_\_\_\_\_ છે.

( $g = 10 \text{ m/s}^2$  લો.)

Options :

1.  $\tan^{-1}(0.5)$
2.  $\tan^{-1}(5.0)$
3.  $\tan^{-1}(2.0)$
4.  $\tan^{-1}(0.2)$

Question Number : 15 Question Type : MCQ Option Shuffling : Yes Display Question Number : Yes Single Line Question Option : No Option Orientation : Vertical

Correct Marks : 4 Wrong Marks : 1

A solid conducting sphere, having a charge  $Q$ , is surrounded by an uncharged conducting hollow spherical shell. Let the potential difference between the surface of the solid sphere and that of the outer surface of the hollow shell be  $V$ . If the shell is now given a charge of  $-4Q$ , the new potential difference between the same two surfaces is :

Options :

1.  $V$
2.  $2V$
3.  $-2V$
4.  $4V$

Question Number : 15 Question Type : MCQ Option Shuffling : Yes Display Question Number : Yes Single Line Question Option : No Option Orientation : Vertical

Correct Marks : 4 Wrong Marks : 1

आवेश  $Q$  वाले एक ठोस चालकीय गोले को एक अनावेशित चालकीय खोखले गोलीय कवच से घेरा गया है। ठोस गोले के पृष्ठ और खोखले कवच के बाह्य पृष्ठ के बीच विभवान्तर  $V$  है। यदि कवच को अब एक आवेश  $-4Q$  दिया जाता है, तब उन्ही दोनों पृष्ठों के बीच नया विभवान्तर होगा :

Options :

1.  $V$
2.  $2V$

3.  $-2\text{ V}$

4.  $4\text{ V}$

Question Number : 15 Question Type : MCQ Option Shuffling : Yes Display Question Number : Yes Single Line Question Option : No Option Orientation : Vertical

Correct Marks : 4 Wrong Marks : 1

Q વીજભાર ધરાવતા એક ઘન વાહક ગોળો કોઈ વીજભાર રહિત વાહક પોલા ગોળાકાર કવચથી ઘેરાયેલો છે. ધારોકે ઘન ગોળાની સપાટી અને પોલા કવચની બહારની સપાટી વચ્ચેનો સ્થિતિમાનનો તફાવત  $V$  છે. હવે જો પોલા કવચને  $-4Q$  જેટલો વીજભાર આપવામાં આવેતો આજ બે સપાટીઓ વચ્ચે નવો સ્થિતિમાનનો તફાવત \_\_\_\_\_ છે.

Options :

1.  $V$

2.  $2V$

3.  $-2V$

4.  $4V$

Question Number : 16 Question Type : MCQ Option Shuffling : Yes Display Question Number : Yes Single Line Question Option : No Option Orientation : Vertical

Correct Marks : 4 Wrong Marks : 1

Voltage rating of a parallel plate capacitor is  $500\text{ V}$ . Its dielectric can withstand a maximum electric field of  $10^6\text{ V/m}$ . The plate area is  $10^{-4}\text{ m}^2$ . What is the dielectric constant if the capacitance is  $15\text{ pF}$  ?  
(given  $\epsilon_0 = 8.86 \times 10^{-12}\text{ C}^2/\text{Nm}^2$ )

Options :

1.  $6.2$

2.  $3.8$

3.  $4.5$

4.  $8.5$

Question Number : 16 Question Type : MCQ Option Shuffling : Yes Display Question Number : Yes Single Line Question Option : No Option Orientation : Vertical

Correct Marks : 4 Wrong Marks : 1

एक समान्तर प्लेट संधारित्र की वोल्टेज श्रेणी (rating) 500 V है। इसका परावैद्युत पदार्थ अधिकतम  $10^6$  V/m का विद्युत क्षेत्र सहन कर सकता है। प्लेट का क्षेत्रफल  $10^{-4}$  m<sup>2</sup> है। यदि संधारित्र की धारिता का मान 15 pF हो तो परावैद्युतांक का मान होगा :  
(दिया है  $\epsilon_0 = 8.86 \times 10^{-12}$  C<sup>2</sup>/Nm<sup>2</sup>)

Options :

1. 6.2
2. 3.8
3. 4.5
4. 8.5

Question Number : 16 Question Type : MCQ Option Shuffling : Yes Display Question Number : Yes Single Line Question Option : No Option Orientation : Vertical

Correct Marks : 4 Wrong Marks : 1

समान्तर प्लेट કેપેસિટરનું વોલ્ટેજ રેટિંગ 500 V છે. એનું પરાવૈદ્યુત સામર્થ્ય  $10^6$  V/m મહત્તમ વિદ્યુતક્ષેત્ર જેટલું સહન કરી શકે છે. પ્લેટનું ક્ષેત્રફળ  $10^{-4}$  m<sup>2</sup> છે. 15 pF કેપેસિટન્સ માટે પરાવૈદ્યુતાંક (ડાયઇલેક્ટ્રીક અચળાંક) કેટલો હોવો જોઈએ? ( $\epsilon_0 = 8.86 \times 10^{-12}$  C<sup>2</sup>/Nm<sup>2</sup> છે.)

Options :

1. 6.2
2. 3.8
3. 4.5
4. 8.5

Question Number : 17 Question Type : MCQ Option Shuffling : Yes Display Question Number : Yes Single Line Question Option : No Option Orientation : Vertical

Correct Marks : 4 Wrong Marks : 1

For the circuit shown, with  $R_1 = 1.0 \Omega$ ,  $R_2 = 2.0 \Omega$ ,  $E_1 = 2 \text{ V}$  and  $E_2 = E_3 = 4 \text{ V}$ , the potential difference between the points 'a' and 'b' is approximately ( in V ) :

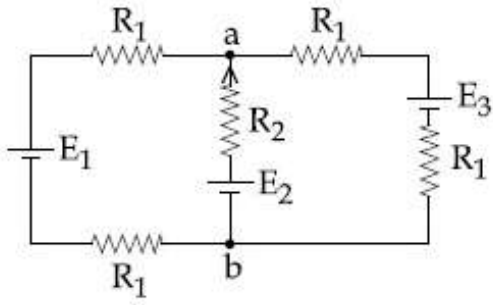

Options :

1. 3.7
2. 3.3
3. 2.7
4. 2.3

Question Number : 17 Question Type : MCQ Option Shuffling : Yes Display Question Number : Yes Single Line Question Option : No Option Orientation : Vertical

Correct Marks : 4 Wrong Marks : 1

दिखाये गये परिपथ में,  $R_1 = 1.0 \Omega$ ,  $R_2 = 2.0 \Omega$ ,  $E_1 = 2 \text{ V}$  और  $E_2 = E_3 = 4 \text{ V}$  हैं। बिन्दुओं 'a' एवं 'b' के बीच विभवान्तर लगभग (V में) है :

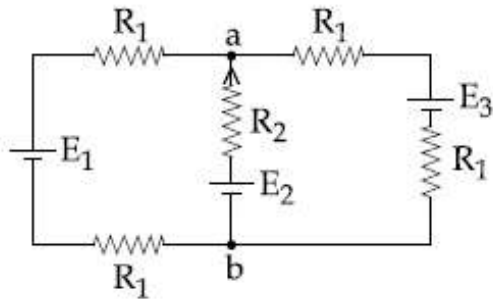

Options :

1. 3.7
2. 3.3
3. 2.7
4. 2.3

Correct Marks : 4 Wrong Marks : 1

બતાવેલ પરિપથમાં  $R_1 = 1.0 \Omega$ ,  $R_2 = 2.0 \Omega$ ,  $E_1 = 2V$   
અને  $E_2 = E_3 = 4 V$  છે. બિન્દુ a અને b વચ્ચે  
સ્થિતિમાનનો તફાવત અંદાજત (વોલ્ટમાં) \_\_\_\_\_  
છે.

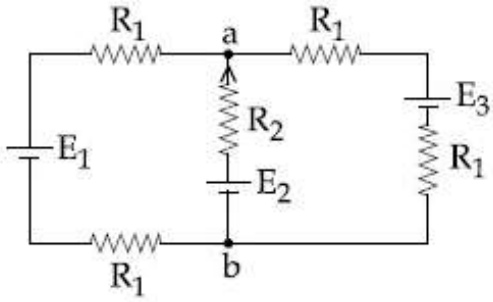

Options :

1. 3.7
2. 3.3
3. 2.7
4. 2.3

Question Number : 18 Question Type : MCQ Option Shuffling : Yes Display Question Number : Yes Single Line Question Option : No Option Orientation : Vertical

Correct Marks : 4 Wrong Marks : 1

A circular coil having  $N$  turns and radius  $r$   
carries a current  $I$ . It is held in the  $XZ$  plane  
in a magnetic field  $B \hat{i}$ . The torque on the  
coil due to the magnetic field is :

Options :

1.  $B\pi r^2 I N$
2.  $\frac{B\pi r^2 I}{N}$
3. Zero
4.  $\frac{Br^2 I}{\pi N}$

Question Number : 18 Question Type : MCQ Option Shuffling : Yes Display Question Number : Yes Single Line Question Option : No Option Orientation : Vertical

Correct Marks : 4 Wrong Marks : 1



त्रिज्या  $r$  और चक्कर  $N$  वाली एक वृत्तीय कुण्डली में धारा  $I$  प्रवाहित हो रही है। इसे चुम्बकीय क्षेत्र  $B \hat{i}$  में  $XZ$  समतल में रखा जाता है। चुम्बकीय क्षेत्र के कारण कुण्डली पर बलआघूर्ण होगा :

Options :

1.  $B\pi r^2 I N$

2.  $\frac{B\pi r^2 I}{N}$

3. शून्य

4.  $\frac{Br^2 I}{\pi N}$

Question Number : 18 Question Type : MCQ Option Shuffling : Yes Display Question Number : Yes Single Line Question Option : No Option Orientation : Vertical

Correct Marks : 4 Wrong Marks : 1

$N$  આંટા અને  $r$  ત્રિજ્યાવાળું એક વર્તુળાકાર ગુંચળું  $I$

પ્રવાહ ધરાવે છે. તેને  $B \hat{i}$  તીવ્રતાવાળા ચુંબકીય ક્ષેત્રમાં  $XZ$  સમતલમાં લટકાવેલ છે. ચુંબકીય ક્ષેત્રને લીધે ગુંચળા પર લાગતું બળયુગ્મ (ટોર્ક) \_\_\_\_\_ હશે.

Options :

1.  $B\pi r^2 I N$

2.  $\frac{B\pi r^2 I}{N}$

3. શૂન્ય

4.  $\frac{Br^2 I}{\pi N}$

Question Number : 19 Question Type : MCQ Option Shuffling : Yes Display Question Number : Yes Single Line Question Option : No Option Orientation : Vertical

Correct Marks : 4 Wrong Marks : 1



An alternating voltage  $v(t) = 220 \sin 100\pi t$  volt is applied to a purely resistive load of  $50 \Omega$ . The time taken for the current to rise from half of the peak value to the peak value is :

Options :

1. 2.2 ms
2. 3.3 ms
3. 5 ms
4. 7.2 ms

Question Number : 19 Question Type : MCQ Option Shuffling : Yes Display Question Number : Yes Single Line Question Option : No Option Orientation : Vertical

Correct Marks : 4 Wrong Marks : 1

एक प्रत्यावर्ती वोल्टेज स्रोत  $v(t) = 220 \sin 100\pi t$  वोल्ट को एक  $50 \Omega$  प्रतिरोध पर लगाया गया है। धारा का मान आधे शिखर मान से पूर्ण शिखर मान तक बढ़ने में लगे समय का मान होगा :

Options :

1. 2.2 ms
2. 3.3 ms
3. 5 ms
4. 7.2 ms

Question Number : 19 Question Type : MCQ Option Shuffling : Yes Display Question Number : Yes Single Line Question Option : No Option Orientation : Vertical

Correct Marks : 4 Wrong Marks : 1

$50 \Omega$  अवरोध धरावत्ता अवरोधने  $v(t) = 220 \sin 100\pi t$  volt वाणी अल्टरनेट (वोल्ट सुलट) वीजस्थितिमान लगाववाમાં આવે છે. પ્રવાહને તેના અડધા મહત્તમ (પીક) મૂલ્ય થી મહત્તમ (પીક) મૂલ્ય સુધી જવા માટે લાગતો સમય અંતરાલ છે :

Options :

1. 2.2 ms

2. 3.3 ms
3. 5 ms
4. 7.2 ms

Question Number : 20 Question Type : MCQ Option Shuffling : Yes Display Question Number : Yes Single Line Question Option : No Option Orientation : Vertical

Correct Marks : 4 Wrong Marks : 1

A thin strip 10 cm long is on a U shaped wire of negligible resistance and it is connected to a spring of spring constant  $0.5 \text{ Nm}^{-1}$  (see figure). The assembly is kept in a uniform magnetic field of 0.1 T. If the strip is pulled from its equilibrium position and released, the number of oscillations it performs before its amplitude decreases by a factor of  $e$  is  $N$ . If the mass of the strip is 50 grams, its resistance  $10 \Omega$  and air drag negligible,  $N$  will be close to :

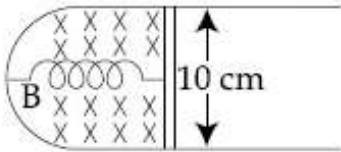

Options :

1. 1000
2. 5000
3. 10000
4. 50000

Question Number : 20 Question Type : MCQ Option Shuffling : Yes Display Question Number : Yes Single Line Question Option : No Option Orientation : Vertical

Correct Marks : 4 Wrong Marks : 1

नगण्य प्रतिरोध वाले एक U आकार के तार पर 10 cm लम्बी एक पतली पट्टी रखी है और इसे 0.5 N/m कमानी स्थिरांक वाली एक कमानी से जोड़ा गया है। (चित्र देखें)। समायोजन को एक 0.1 T के एकसमान चुम्बकीय क्षेत्र में रखा गया है। यदि पट्टी को इसकी साम्यावस्था से खींचा जाता है और फिर छोड़ दिया जाता है, तब इसके आयाम में  $e$  के गुणक से कमी आने के लिये किये गये दोलनों की संख्या  $N$  है। यदि पट्टी का द्रव्यमान 50 ग्राम है, इसका प्रतिरोध  $10 \Omega$  हैं और वायु अवरोध (drag) नगण्य है, तब  $N$  का मान लगभग होगा :

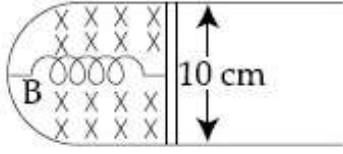

Options :

1. 1000
2. 5000
3. 10000
4. 50000

Question Number : 20 Question Type : MCQ Option Shuffling : Yes Display Question Number : Yes Single Line Question Option : No Option Orientation : Vertical

Correct Marks : 4 Wrong Marks : 1

अवगण्य अवरोध धरावता U आकारना तार पर 10 cm लांबी एक पातणी पट्टीने मुकवामां आवेल छे. अने तेने 0.5 Nm<sup>-1</sup> स्प्रिंग अचणांक धरावती स्प्रिंग वडे जडीत करेल छे. (आकृति बुओ). आ रचनाने 0.1 T वाणा चुंबकीय क्षेत्रमां मुकवामां आवे छे. ज्यारे पट्टीने तेनी संतुलन अवस्थामांथी भेंचीने छोडवामां आवे छे त्यारे तेनो कंपविस्तार  $e$  जेटलो घटे ते पहेला थता दोलनोनी संख्या  $N$  छे. जे पट्टीनो द्रव्य 50 gm, अवरोध  $10 \Omega$  अने अवगण्य हवानुं भेयाइ लोय तो  $N$  \_\_\_\_\_ नी नञ्जक हरो.

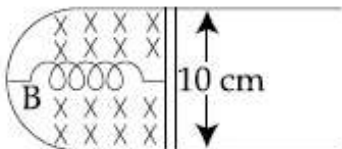

Options :

1. 1000

2. 5000
3. 10000
4. 50000

Question Number : 21 Question Type : MCQ Option Shuffling : Yes Display Question Number : Yes Single Line Question Option : No Option Orientation : Vertical

Correct Marks : 4 Wrong Marks : 1

A 20 Henry inductor coil is connected to a 10 ohm resistance in series as shown in figure. The time at which rate of dissipation of energy (Joule's heat) across resistance is equal to the rate at which magnetic energy is stored in the inductor, is :

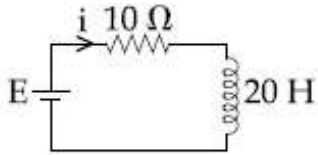

Options :

1.  $\frac{1}{2} \ln 2$
2.  $2 \ln 2$
3.  $\frac{2}{\ln 2}$
4.  $\ln 2$

Question Number : 21 Question Type : MCQ Option Shuffling : Yes Display Question Number : Yes Single Line Question Option : No Option Orientation : Vertical

Correct Marks : 4 Wrong Marks : 1

एक 20 हेनरी प्रेरण कुण्डली को 10 ओह्म प्रतिरोध से श्रेणी में जोड़ा गया है जैसा कि चित्र में दर्शाया गया है। जब प्रतिरोध में क्षय ऊर्जा (जूल ऊष्मा) की दर प्रेरण कुण्डली में संचित चुम्बकीय ऊर्जा की दर के समान हो, उस समय की गणना कीजिये।

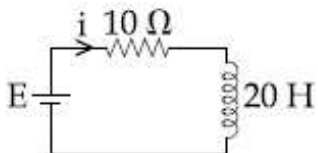

Options :

1.  $\frac{1}{2} \ln 2$

2.  $2 \ln 2$

3.  $\frac{2}{\ln 2}$

4.  $\ln 2$

Question Number : 21 Question Type : MCQ Option Shuffling : Yes Display Question Number : Yes Single Line Question Option : No Option Orientation : Vertical

Correct Marks : 4 Wrong Marks : 1

આકૃતિમાં બતાવ્યા પ્રમાણે 20 Henry ના ગુંચળાને 10 Ω ના અવરોધ સાથે શ્રેણીમાં જોડેલ છે. જ્યારે અવરોધને સમાંતર ઉર્જા વ્યયનો દર (જુલ ઉષ્મા) ગુંચળામાં સંગ્રહ પામતી ચુંબકીય ઉર્જાના દર બરાબર થાય તે માટે લાગતો સમય \_\_\_\_\_ છે.

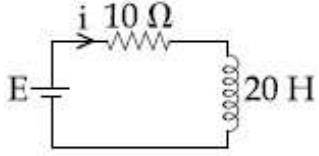

Options :

1.  $\frac{1}{2} \ln 2$

2.  $2 \ln 2$

3.  $\frac{2}{\ln 2}$

4.  $\ln 2$

Question Number : 22 Question Type : MCQ Option Shuffling : Yes Display Question Number : Yes Single Line Question Option : No Option Orientation : Vertical

Correct Marks : 4 Wrong Marks : 1

A plane electromagnetic wave travels in free space along the  $x$ -direction. The electric field component of the wave at a particular point of space and time is  $E = 6 \text{ Vm}^{-1}$  along  $y$ -direction. Its corresponding magnetic field component,  $B$  would be :

Options :



1.  $2 \times 10^{-8}$  T along z-direction
2.  $6 \times 10^{-8}$  T along x-direction
3.  $2 \times 10^{-8}$  T along y-direction
4.  $6 \times 10^{-8}$  T along z-direction

Question Number : 22 Question Type : MCQ Option Shuffling : Yes Display Question Number : Yes Single Line Question Option : No Option Orientation : Vertical

Correct Marks : 4 Wrong Marks : 1

एक समतल विद्युत चुम्बकीय तरंग मुक्त आकाश में  $x$ -दिशा में गतिशील है। आकाश के एक विशेष बिन्दु पर तरंग का विद्युत क्षेत्र घटक, एक समय पर  $E = 6 \text{ Vm}^{-1}$   $y$ -दिशा में है। उसके संगत इसका चुम्बकीय क्षेत्र घटक B होगा :

Options :

1.  $z$ -दिशा में  $2 \times 10^{-8}$  T
2.  $x$ -दिशा में  $6 \times 10^{-8}$  T
3.  $y$ -दिशा में  $2 \times 10^{-8}$  T
4.  $z$ -दिशा में  $6 \times 10^{-8}$  T

Question Number : 22 Question Type : MCQ Option Shuffling : Yes Display Question Number : Yes Single Line Question Option : No Option Orientation : Vertical

Correct Marks : 4 Wrong Marks : 1

કોઈ સમતલ વિદ્યુત ચુંબકીય તરંગો મુક્ત અવકાશમાં  $x$ -અક્ષને સમાંતર ગતિ કરે છે.  $y$ -અક્ષને સમાંતર અવકાશના કોઈ ચોક્કસ બિન્દુ અને સમયે તરંગના વિદ્યુત ક્ષેત્રનો ઘટક  $E = 6 \text{ Vm}^{-1}$  છે. આજ બિન્દુએ તેના ચુંબકીય ક્ષેત્રનો ઘટક B \_\_\_\_\_ હશે.

Options :

1.  $z$ -અક્ષને સમાંતર  $2 \times 10^{-8}$  T
2.  $x$ -અક્ષને સમાંતર  $6 \times 10^{-8}$  T
3.  $y$ -અક્ષને સમાંતર  $2 \times 10^{-8}$  T

4. z-अक्षने समांतर  $6 \times 10^{-8} \text{ T}$

Question Number : 23 Question Type : MCQ Option Shuffling : Yes Display Question Number : Yes Single Line Question Option : No Option Orientation : Vertical

Correct Marks : 4 Wrong Marks : 1

An upright object is placed at a distance of 40 cm in front of a convergent lens of focal length 20 cm. A convergent mirror of focal length 10 cm is placed at a distance of 60 cm on the other side of the lens. The position and size of the final image will be :

Options :

1. 40 cm from the convergent mirror, same size as the object
2. 20 cm from the convergent mirror, same size as the object
3. 20 cm from the convergent mirror, twice the size of the object
4. 40 cm from the convergent lens, twice the size of the object

Question Number : 23 Question Type : MCQ Option Shuffling : Yes Display Question Number : Yes Single Line Question Option : No Option Orientation : Vertical

Correct Marks : 4 Wrong Marks : 1

20 cm फोकस लम्बाई वाले एक अभिसारी लेन्स के सामने 40 cm की दूरी पर एक सीधी वस्तु को रखा गया है। लेन्स के दूसरी ओर 60 cm की दूरी पर 10 cm फोकस लम्बाई वाले एक अभिसारी दर्पण को रखा गया है। अन्तिम प्रतिबिम्ब की स्थिति और आकार होगा :

Options :

1. अभिसारी दर्पण से 40 cm पर, वस्तु के समान आकार का
2. अभिसारी दर्पण से 20 cm पर, वस्तु के समान आकार का



3. અભિસારી દર્પણ સે 20 cm પર, વસ્તુ કે આકાર  
કા ઢોગુના

4. અભિસારી લેન્સ સે 40 cm પર, વસ્તુ કે આકાર  
કા ઢોગુના

Question Number : 23 Question Type : MCQ Option Shuffling : Yes Display Question Number : Yes Single Line Question Option :  
No Option Orientation : Vertical

Correct Marks : 4 Wrong Marks : 1

એક ઊભી વસ્તુને 20 cm કેન્દ્રલંબાઈ ઘરાવતા એક  
કેન્દ્રાભિસારી લેન્સની સામે 40 cm અંતરે મુકેલ છે.  
લેન્સની બીજી બાજુએ 60 cm અંતરે એક કેન્દ્રાભિસારી  
અરીસો 10 cm અંતરે મુકેલ છે. પરિણામી પ્રતિબિંબની  
સ્થિતિ અને કદ હશે :

Options :

1. કેન્દ્રાભિસારી અરીસાથી 40 cm, વસ્તુના જેટલું  
જ કદ

2. કેન્દ્રાભિસારી અરીસાથી 20 cm, વસ્તુના જેટલું  
જ કદ

3. કેન્દ્રાભિસારી અરીસાથી 20 cm, વસ્તુથી બે ગણા  
કદનું

4. કેન્દ્રાભિસારી લેન્સથી 40 cm, વસ્તુથી બે ગણા  
કદનું

Question Number : 24 Question Type : MCQ Option Shuffling : Yes Display Question Number : Yes Single Line Question Option :  
No Option Orientation : Vertical

Correct Marks : 4 Wrong Marks : 1

In an interference experiment the ratio of

amplitudes of coherent waves is  $\frac{a_1}{a_2} = \frac{1}{3}$ .

The ratio of maximum and minimum  
intensities of fringes will be :

Options :

1. 2

2. 4

3. 9

4. 18

Question Number : 24 Question Type : MCQ Option Shuffling : Yes Display Question Number : Yes Single Line Question Option : No Option Orientation : Vertical

Correct Marks : 4 Wrong Marks : 1

किसी व्यतिकरण के प्रयोग में कलाबद्ध स्रोतों के आयामों

का अनुपात  $\frac{a_1}{a_2} = \frac{1}{3}$  हैं। फ्रिंजों की अधिकतम और

न्यूनतम तीव्रताओं का अनुपात होगा :

Options :

1. 2

2. 4

3. 9

4. 18

Question Number : 24 Question Type : MCQ Option Shuffling : Yes Display Question Number : Yes Single Line Question Option : No Option Orientation : Vertical

Correct Marks : 4 Wrong Marks : 1

कोई एक व्यतिकरणा प्रयोगमां सुसभज्द तरंगोना

कंपविस्तारनो गुणोत्तर  $\frac{a_1}{a_2} = \frac{1}{3}$  छे. शलाकाओनी

महत्तम अने न्यूनतम तीव्रतानो गुणोत्तर  $I_{max}/I_{min}$

हशे :

Options :

1. 2

2. 4

3. 9

4. 18

Question Number : 25 Question Type : MCQ Option Shuffling : Yes Display Question Number : Yes Single Line Question Option : No Option Orientation : Vertical

Correct Marks : 4 Wrong Marks : 1

In figure, the optical fiber is  $l=2$  m long and has a diameter of  $d=20\ \mu\text{m}$ . If a ray of light is incident on one end of the fiber at angle  $\theta_1=40^\circ$ , the number of reflections it makes before emerging from the other end is close to :

(refractive index of fiber is 1.31 and  $\sin 40^\circ=0.64$ )

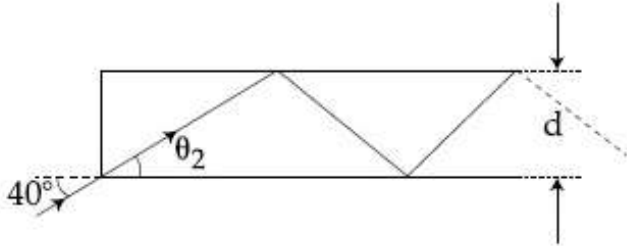

Options :

1. 57000
2. 66000
3. 55000
4. 45000

Question Number : 25 Question Type : MCQ Option Shuffling : Yes Display Question Number : Yes Single Line Question Option : No Option Orientation : Vertical

Correct Marks : 4 Wrong Marks : 1

चित्र में  $l=2$  मीटर लम्बे तथा  $d=20\ \mu\text{m}$  व्यास के एक प्रकाश तन्तु को दिखाया है। यदि प्रकाश की किरण इस तन्तु के एक सिरे पर  $\theta_1=40^\circ$  कोण पर आपतित होती है तो दूसरे सिरे से निकलने से पूर्व इसके परावर्तनों की लगभग संख्या होगी :

(फाइबर का अपवर्तनांक 1.31 है और  $\sin 40^\circ=0.64$ )

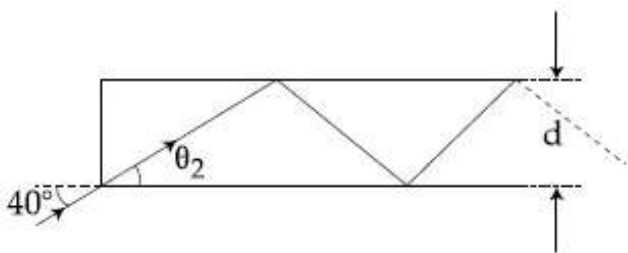

Options :

1. 57000
2. 66000

3. 55000

4. 45000

Question Number : 25 Question Type : MCQ Option Shuffling : Yes Display Question Number : Yes Single Line Question Option : No Option Orientation : Vertical

Correct Marks : 4 Wrong Marks : 1

એક પ્રકાશપુંજ  $\theta_1 = 40^\circ$  ના ખૂણે  $l = 2 \text{ m}$  લાંબા અને  $d = 20 \mu\text{m}$  વ્યાસ ધરાવતા ઓપ્ટિકલ ફાઇબર ના એક છેડા પર આપાત થાય છે. બીજા છેડાથી બહાર નિકળતા પહેલા એના દ્વારા કેટલા પરાવર્તનોની સંખ્યા \_\_\_\_\_ ની નજીકની હશે.

(ફાઇબરનો વક્રીભવનાંક 1.31 અને  $\sin 40^\circ = 0.64$ )

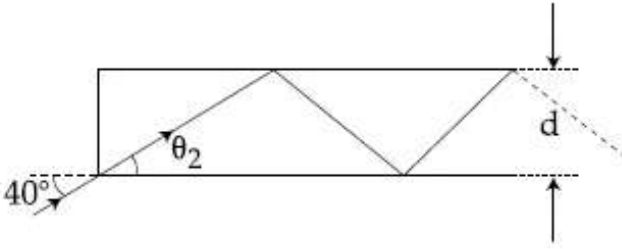

Options :

1. 57000

2. 66000

3. 55000

4. 45000

Question Number : 26 Question Type : MCQ Option Shuffling : Yes Display Question Number : Yes Single Line Question Option : No Option Orientation : Vertical

Correct Marks : 4 Wrong Marks : 1

Two particles move at right angle to each other. Their de Broglie wavelengths are  $\lambda_1$  and  $\lambda_2$  respectively. The particles suffer perfectly *inelastic* collision. The de Broglie wavelength  $\lambda$ , of the final particle, is given by :

Options :

1.  $\lambda = \frac{\lambda_1 + \lambda_2}{2}$

2.  $\lambda = \sqrt{\lambda_1 \lambda_2}$

$$3. \frac{2}{\lambda} = \frac{1}{\lambda_1} + \frac{1}{\lambda_2}$$

$$4. \frac{1}{\lambda^2} = \frac{1}{\lambda_1^2} + \frac{1}{\lambda_2^2}$$

Question Number : 26 Question Type : MCQ Option Shuffling : Yes Display Question Number : Yes Single Line Question Option : No Option Orientation : Vertical

Correct Marks : 4 Wrong Marks : 1

दो कण एक दूसरे से लम्बवत् दिशाओं में गतिशील हैं। इन कणों की डी-ब्राग्ली तरंग लम्बाइयाँ क्रमशः  $\lambda_1$  तथा  $\lambda_2$  हैं। इन कणों का पूर्णतया अप्रत्यास्थ संघट्ट होता है। परिणामी कण की डी-ब्राग्ली तरंगदैर्घ्य  $\lambda$  इस समीकरण से दी जाती है :

Options :

$$1. \lambda = \frac{\lambda_1 + \lambda_2}{2}$$

$$2. \lambda = \sqrt{\lambda_1 \lambda_2}$$

$$3. \frac{2}{\lambda} = \frac{1}{\lambda_1} + \frac{1}{\lambda_2}$$

$$4. \frac{1}{\lambda^2} = \frac{1}{\lambda_1^2} + \frac{1}{\lambda_2^2}$$

Question Number : 26 Question Type : MCQ Option Shuffling : Yes Display Question Number : Yes Single Line Question Option : No Option Orientation : Vertical

Correct Marks : 4 Wrong Marks : 1

બે કણો એકબીજાની સાપેક્ષે લંબ ગતિ કરે છે. તેમની ડી બ્રોગલી તરંગલંબાઈ અનુક્રમે  $\lambda_1$  અને  $\lambda_2$  છે. આ કણો સંપૂર્ણ અસ્થિતિસ્થાપક અથડામણ અનુભવે છે. પરિણામી કણની ડી બ્રોગલી તરંગલંબાઈ \_\_\_\_\_ સમીકરણ દ્વારા આપવામાં આવે છે.

Options :

$$1. \lambda = \frac{\lambda_1 + \lambda_2}{2}$$

$$2. \lambda = \sqrt{\lambda_1 \lambda_2}$$

$$3. \frac{2}{\lambda} = \frac{1}{\lambda_1} + \frac{1}{\lambda_2}$$

$$4. \frac{1}{\lambda^2} = \frac{1}{\lambda_1^2} + \frac{1}{\lambda_2^2}$$

Question Number : 27 Question Type : MCQ Option Shuffling : Yes Display Question Number : Yes Single Line Question Option : No Option Orientation : Vertical

Correct Marks : 4 Wrong Marks : 1

Radiation coming from transitions  $n=2$  to  $n=1$  of hydrogen atoms fall on  $\text{He}^+$  ions in  $n=1$  and  $n=2$  states. The possible transition of helium ions as they absorb energy from the radiation is :

Options :

1.  $n=2 \rightarrow n=5$

2.  $n=1 \rightarrow n=4$

3.  $n=2 \rightarrow n=3$

4.  $n=2 \rightarrow n=4$

Question Number : 27 Question Type : MCQ Option Shuffling : Yes Display Question Number : Yes Single Line Question Option : No Option Orientation : Vertical

Correct Marks : 4 Wrong Marks : 1

हाइड्रोजन परमाणु के  $n=2$  से  $n=1$  संक्रमण से निकला विकिरण  $\text{He}^+$  की  $n=1$  और  $n=2$  अवस्थाओं पर पड़ता है। हीलियम आयनों द्वारा इस विकिरण की ऊर्जा शोषण से संभव संक्रमण है :

Options :

1.  $n=2 \rightarrow n=5$

2.  $n=1 \rightarrow n=4$

3.  $n=2 \rightarrow n=3$

4.  $n=2 \rightarrow n=4$

Question Number : 27 Question Type : MCQ Option Shuffling : Yes Display Question Number : Yes Single Line Question Option : No Option Orientation : Vertical

Correct Marks : 4 Wrong Marks : 1



હાઇડ્રોજન પરમાણુની  $n=2$  થી  $n=1$  સંક્રાંતિ દરમિયાન આવતા વિકિરણો હિલીયમ આયનના  $\text{He}^+$   $n=1$  અને  $n=2$  અવસ્થા પર સંપાત થાય છે. હિલીયમ આયન દ્વારા આ વિકિરણો માંથી શોષાતી ઊર્જા વડે થતી શક્ય સંક્રાંતિઓ \_\_\_\_\_ છે.

Options :

1.  $n=2 \rightarrow n=5$

2.  $n=1 \rightarrow n=4$

3.  $n=2 \rightarrow n=3$

4.  $n=2 \rightarrow n=4$

Question Number : 28 Question Type : MCQ Option Shuffling : Yes Display Question Number : Yes Single Line Question Option : No Option Orientation : Vertical

Correct Marks : 4 Wrong Marks : 1

The reverse breakdown voltage of a Zener diode is 5.6 V in the given circuit.

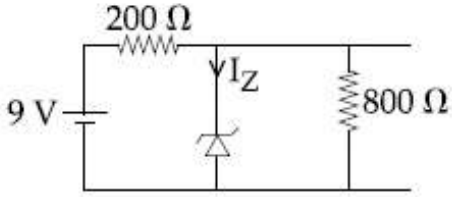

The current  $I_Z$  through the Zener is :

Options :

1. 15 mA

2. 10 mA

3. 7 mA

4. 17 mA

Question Number : 28 Question Type : MCQ Option Shuffling : Yes Display Question Number : Yes Single Line Question Option : No Option Orientation : Vertical

Correct Marks : 4 Wrong Marks : 1

परिपथ में, जीनर की पश्चदिशिक भंजन वोल्टता 5.6 V है। जीनर में धारा  $I_Z$  हैं :

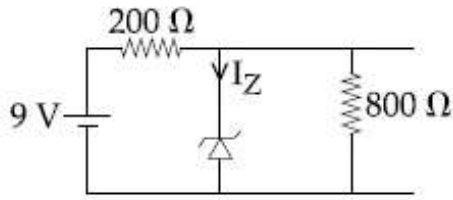

Options :

1. 15 mA
2. 10 mA
3. 7 mA
4. 17 mA

Question Number : 28 Question Type : MCQ Option Shuffling : Yes Display Question Number : Yes Single Line Question Option : No Option Orientation : Vertical

Correct Marks : 4 Wrong Marks : 1

આપેલ પરિપથમાં ઝેનર ડાયોડનો રીવર્સ બ્રેક ડાઉન વોલ્ટેજ 5.6 V છે. ઝેનર ડાયોડ માંથી પસાર થતો પ્રવાહ

$I_Z$  છે :

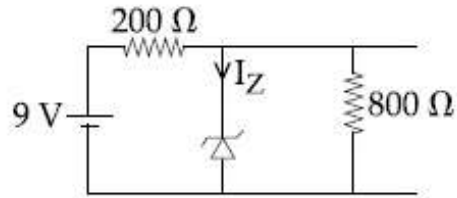

Options :

1. 15 mA
2. 10 mA
3. 7 mA
4. 17 mA

Question Number : 29 Question Type : MCQ Option Shuffling : Yes Display Question Number : Yes Single Line Question Option : No Option Orientation : Vertical

Correct Marks : 4 Wrong Marks : 1

The wavelength of the carrier waves in a modern optical fiber communication network is close to :

Options :

1. 1500 nm
2. 900 nm
3. 2400 nm
4. 600 nm

Question Number : 29 Question Type : MCQ Option Shuffling : Yes Display Question Number : Yes Single Line Question Option : No Option Orientation : Vertical

Correct Marks : 4 Wrong Marks : 1

एक आधुनिक प्रकाशीय फाइबर संचरण जाल में वाहक तरंग की निकटतम तरंगदैर्घ्य है :

Options :

1. 1500 nm
2. 900 nm
3. 2400 nm
4. 600 nm

Question Number : 29 Question Type : MCQ Option Shuffling : Yes Display Question Number : Yes Single Line Question Option : No Option Orientation : Vertical

Correct Marks : 4 Wrong Marks : 1

आधुनिक ओप्टिकल फाइबर संचार परिपथमां डेरीयर तरंगनी तरंगलंबाई \_\_\_\_\_ नी नञ्क छे.

Options :

1. 1500 nm
2. 900 nm
3. 2400 nm
4. 600 nm

Question Number : 30 Question Type : MCQ Option Shuffling : Yes Display Question Number : Yes Single Line Question Option : No Option Orientation : Vertical

Correct Marks : 4 Wrong Marks : 1

A  $200 \Omega$  resistor has a certain color code. If one replaces the red color by green in the code, the new resistance will be :

Options :

1. 100  $\Omega$
2. 300  $\Omega$
3. 400  $\Omega$
4. 500  $\Omega$

Question Number : 30 Question Type : MCQ Option Shuffling : Yes Display Question Number : Yes Single Line Question Option : No Option Orientation : Vertical

Correct Marks : 4 Wrong Marks : 1

200  $\Omega$  के एक प्रतिरोध का एक निश्चित वर्ण संकेत (color code) है। यदि लाल वर्ण को हरे वर्ण से विस्थापित कर देते हैं तो नया प्रतिरोध होगा :

Options :

1. 100  $\Omega$
2. 300  $\Omega$
3. 400  $\Omega$
4. 500  $\Omega$

Question Number : 30 Question Type : MCQ Option Shuffling : Yes Display Question Number : Yes Single Line Question Option : No Option Orientation : Vertical

Correct Marks : 4 Wrong Marks : 1

200  $\Omega$  वाणा अवरोधनो कोछक वार्सकेत आपेल छे. जे लाल कसरनी ब्रज्याअे लीलो कसर लेवामां आवेतो आ नवो अवरोध नो लुशे :

Options :

1. 100  $\Omega$
2. 300  $\Omega$
3. 400  $\Omega$
4. 500  $\Omega$

Section Id :  
Section Number :  
Section type :  
Mandatory or Optional:

Chemistry

416529254

2

Online

Mandatory

Number of Questions:	30
Number of Questions to be attempted:	30
Section Marks:	120
Display Number Panel:	Yes
Group All Questions:	No

Sub-Section Number:	1
Sub-Section Id:	416529394
Question Shuffling Allowed :	Yes

Question Number : 31 Question Type : MCQ Option Shuffling : Yes Display Question Number : Yes Single Line Question Option : No Option Orientation : Vertical

Correct Marks : 4 Wrong Marks : 1

An organic compound neither reacts with neutral ferric chloride solution nor with Fehling solution. It however, reacts with Grignard reagent and gives positive iodoform test. The compound is :

Options :

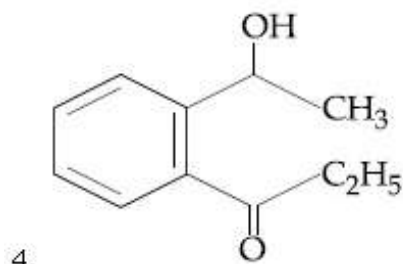
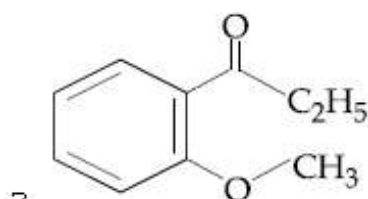
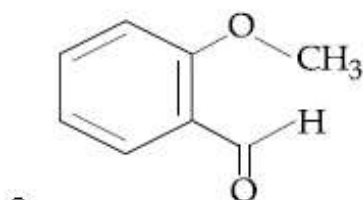
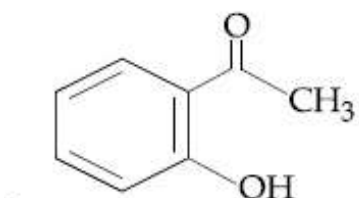

Question Number : 31 Question Type : MCQ Option Shuffling : Yes Display Question Number : Yes Single Line Question Option : No Option Orientation : Vertical

Correct Marks : 4 Wrong Marks : 1

एक कार्बनिक यौगिक न तो उदासीन फेरिक क्लोराइड विलयन के साथ और न ही फेलिंग विलयन के साथ अभिक्रिया करता है। हालाँकि यह यौगिक ग्रीन्यार अभिकर्मक के साथ अभिक्रिया करता है तथा सकारात्मक आयोडोफॉर्म टेस्ट देता है। यह यौगिक है :

Options :

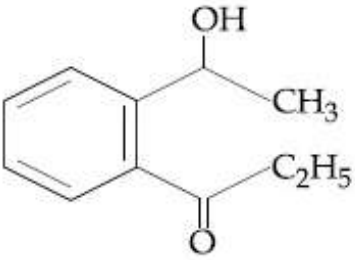
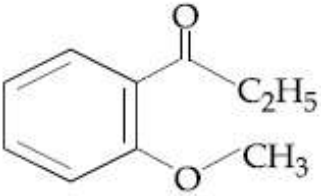
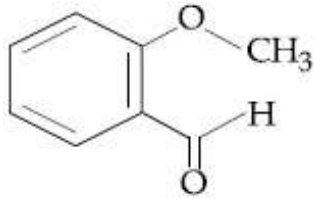
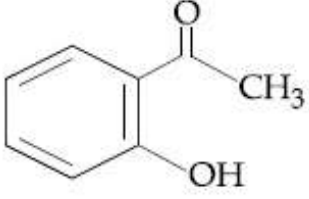

Question Number : 31 Question Type : MCQ Option Shuffling : Yes Display Question Number : Yes Single Line Question Option : No Option Orientation : Vertical

Correct Marks : 4 Wrong Marks : 1

એક કાર્બનિક સંયોજન ના તો તટસ્થ ફેરિક ક્લોરાઇડના દ્રાવણ સાથે કે નહિતો ફેલ્ડિંગ દ્રાવણથી સાથે પ્રક્રિયા કરે છે. પરંતુ તે ગ્રીનિયાર પ્રક્રિયાકર્તા સાથે પ્રક્રિયા કરે છે. અને આયોડોફોર્મની હકારાત્મક કસોટી સાથે છે. આ સંયોજન છે :

Options :

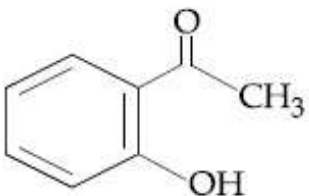



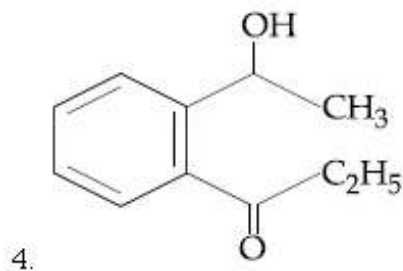
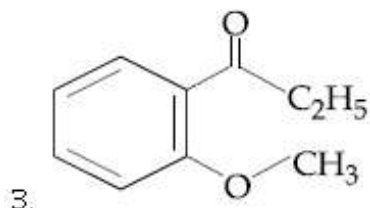
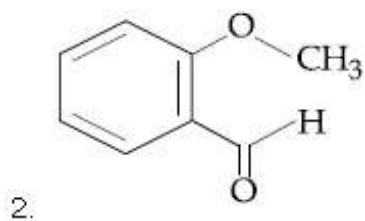

Question Number : 32 Question Type : MCQ Option Shuffling : Yes Display Question Number : Yes Single Line Question Option : No Option Orientation : Vertical

Correct Marks : 4 Wrong Marks : 1

Maltose on treatment with dilute HCl

gives :

Options :

1. D-Galactose
2. D-Glucose and D-Fructose
3. D-Fructose
4. D-Glucose

Question Number : 32 Question Type : MCQ Option Shuffling : Yes Display Question Number : Yes Single Line Question Option : No Option Orientation : Vertical

Correct Marks : 4 Wrong Marks : 1

माल्टोस तनु HCl के साथ अभिकृत करने पर देता है :

Options :

1. D-गैलेक्टोस
2. D-ग्लुकोस तथा D-फ्रुक्टोज
3. D-फ्रुक्टोज

4. D-ग्लुकोस

Question Number : 32 Question Type : MCQ Option Shuffling : Yes Display Question Number : Yes Single Line Question Option : No Option Orientation : Vertical

Correct Marks : 4 Wrong Marks : 1

दुध शर्करानी मंड HCl साथे प्रक्रिया करता शुं मणे?

Options :

1. D-गैलेक्टोज

2. D-सुकोज अने D-फ्रूक्टोज

3. D-फ्रूक्टोज

4. D-सुकोज

Question Number : 33 Question Type : MCQ Option Shuffling : Yes Display Question Number : Yes Single Line Question Option : No Option Orientation : Vertical

Correct Marks : 4 Wrong Marks : 1

Coupling of benzene diazonium chloride with 1-naphthol in alkaline medium will give :

Options :

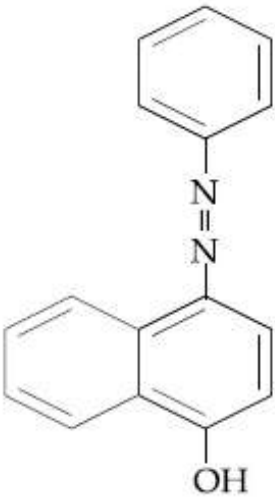

1.

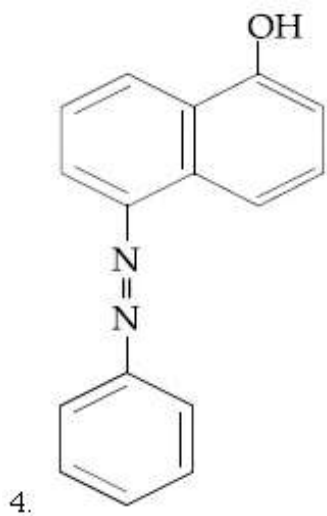
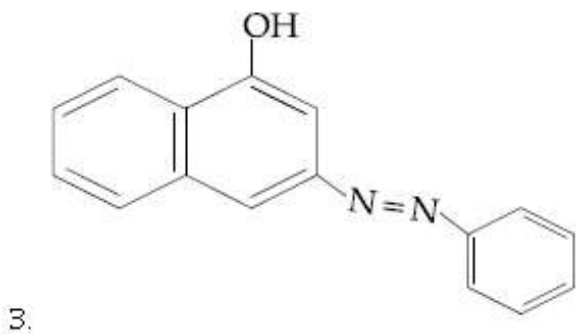
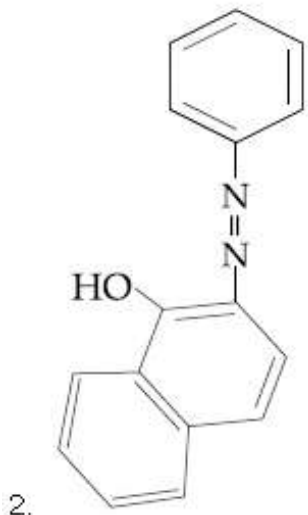

Question Number : 33 Question Type : MCQ Option Shuffling : Yes Display Question Number : Yes Single Line Question Option : No Option Orientation : Vertical

Correct Marks : 4 Wrong Marks : 1

क्षारीय माध्यम में, बेंजीन डाइजोनियम क्लोराइड को 1-नैफ्थॉल के साथ युग्मित करने पर प्राप्त होता है :

Options :

1.

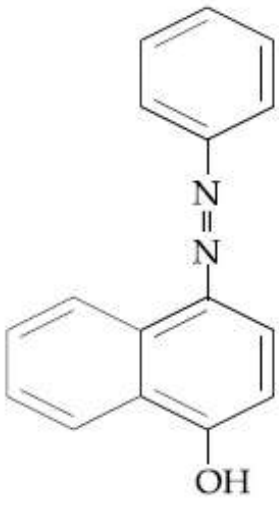

2.

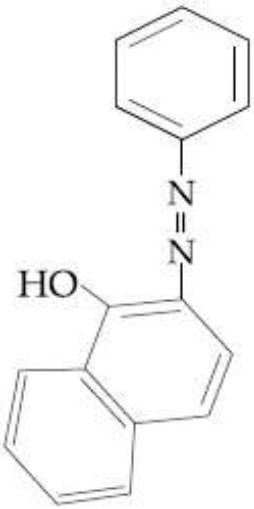

3.

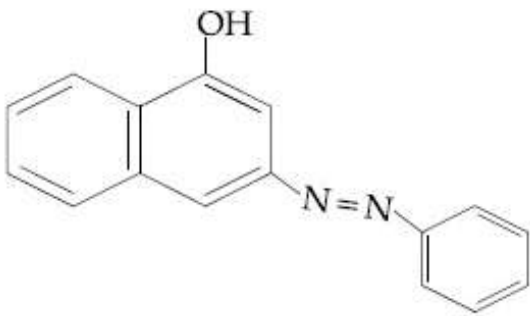

4.

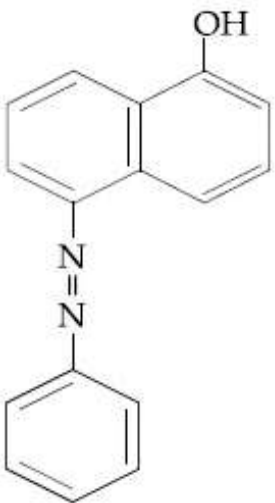

Correct Marks : 4 Wrong Marks : 1

આસ્કલાર્ઇન દ્રાવણમાં બેન્ઝીનડાય એમોનિયમ ક્લોરાઇડનું 1-નેપ્થોલની સાથે કપલિંગ (Coupling) કરતા શું મળે?

Options :

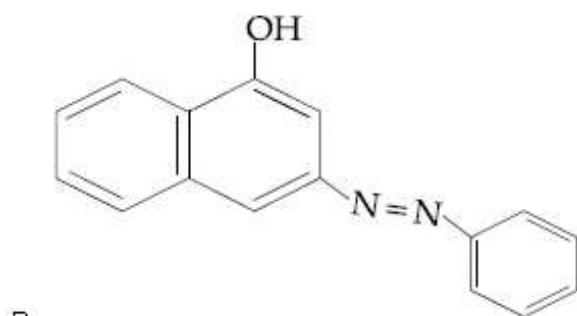
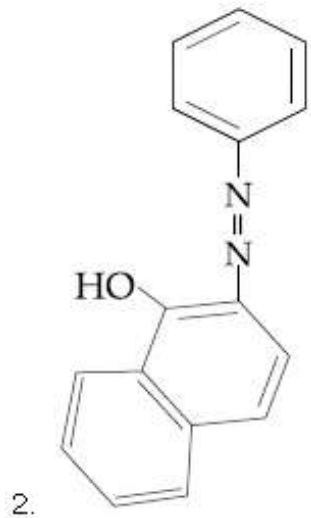
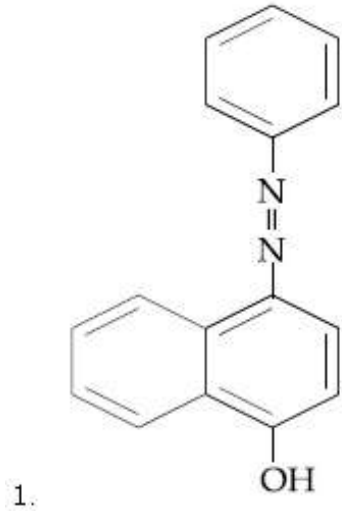

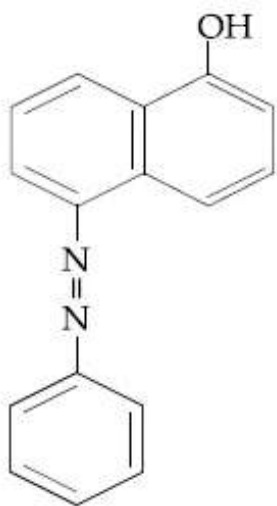

4.

Question Number : 34 Question Type : MCQ Option Shuffling : Yes Display Question Number : Yes Single Line Question Option : No Option Orientation : Vertical

Correct Marks : 4 Wrong Marks : 1

The major product of the following reaction

is :

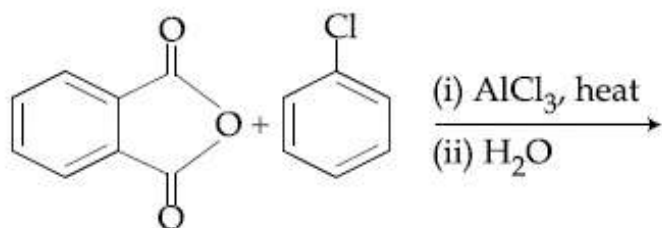

Options :

1.

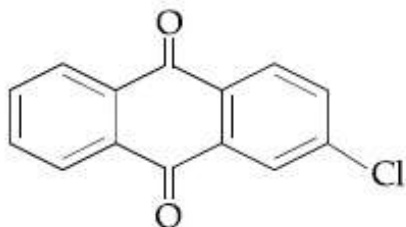

2.

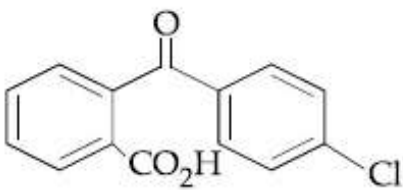

3.

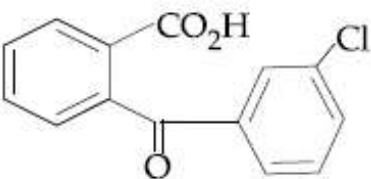



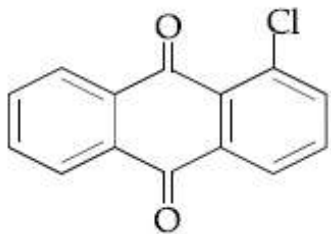

4.

Question Number : 34 Question Type : MCQ Option Shuffling : Yes Display Question Number : Yes Single Line Question Option : No Option Orientation : Vertical

Correct Marks : 4 Wrong Marks : 1

निम्न अभिक्रिया का मुख्य उत्पाद है :

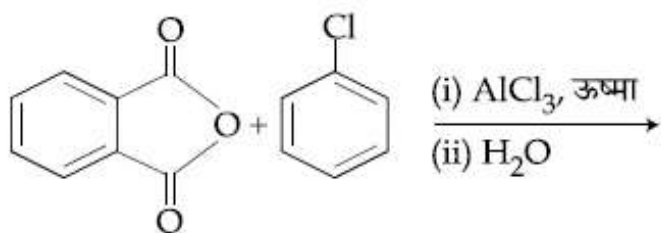

Options :

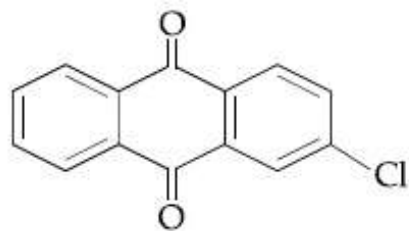

1.

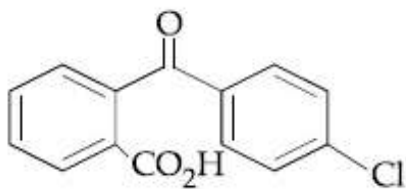

2.

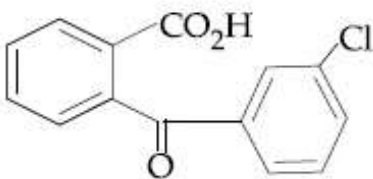

3.

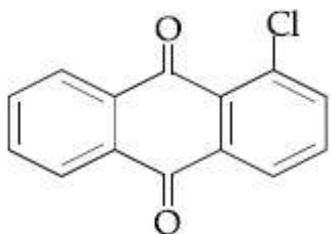

4.

Question Number : 34 Question Type : MCQ Option Shuffling : Yes Display Question Number : Yes Single Line Question Option : No Option Orientation : Vertical

Correct Marks : 4 Wrong Marks : 1

નીચેની પ્રક્રિયાની મુખ્ય નીપજ :

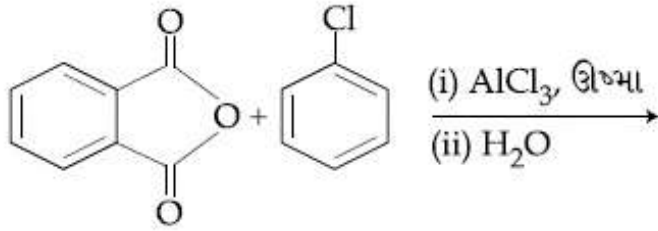

Options :

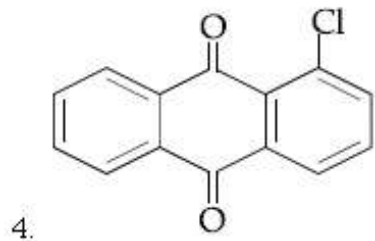
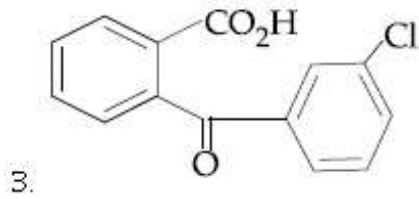
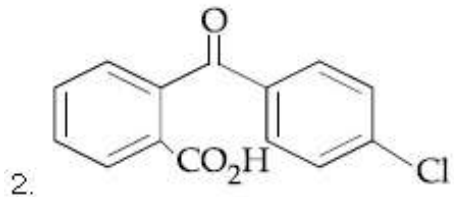
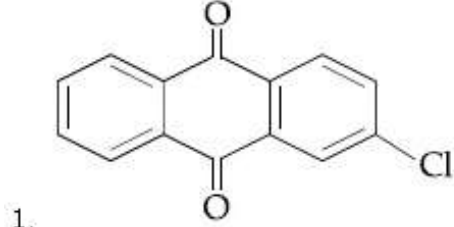

Question Number : 35 Question Type : MCQ Option Shuffling : Yes Display Question Number : Yes Single Line Question Option : No Option Orientation : Vertical

Correct Marks : 4 Wrong Marks : 1

The major product of the following reaction

is :

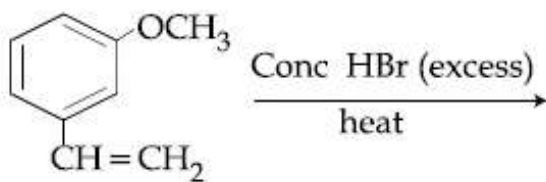

Options :

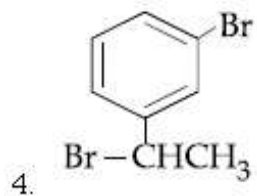
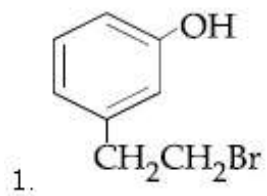

Question Number : 35 Question Type : MCQ Option Shuffling : Yes Display Question Number : Yes Single Line Question Option : No Option Orientation : Vertical

Correct Marks : 4 Wrong Marks : 1

निम्नलिखित अभिक्रिया का मुख्य उत्पाद है :

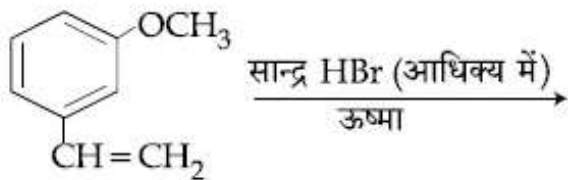

Options :

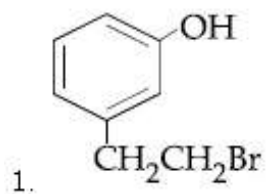

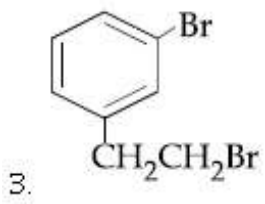

Question Number : 35 Question Type : MCQ Option Shuffling : Yes Display Question Number : Yes Single Line Question Option : No Option Orientation : Vertical

Correct Marks : 4 Wrong Marks : 1

નીચે આપેલી પ્રક્રિયાની મુખ્ય નીપજ છે :

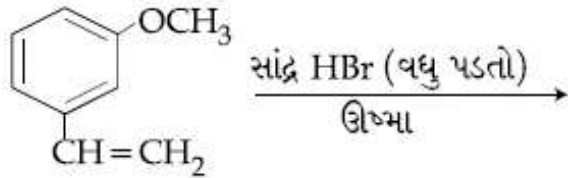

Options :

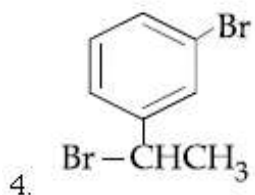
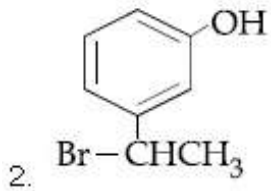
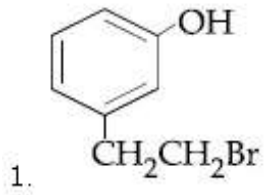

Question Number : 36 Question Type : MCQ Option Shuffling : Yes Display Question Number : Yes Single Line Question Option : No Option Orientation : Vertical

Correct Marks : 4 Wrong Marks : 1

The major product of the following reaction

is :

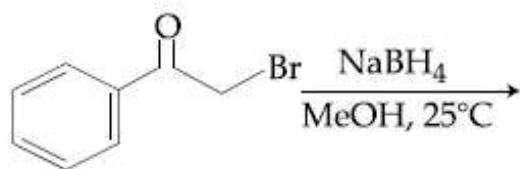

Options :

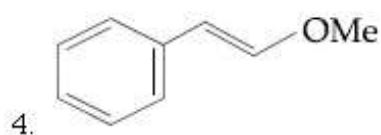
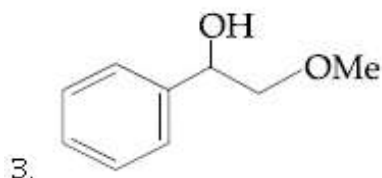
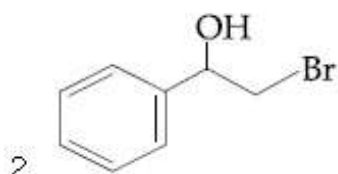
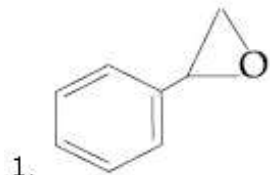

Question Number : 36 Question Type : MCQ Option Shuffling : Yes Display Question Number : Yes Single Line Question Option : No Option Orientation : Vertical

Correct Marks : 4 Wrong Marks : 1

निम्न अभिक्रिया का मुख्य उत्पाद है :

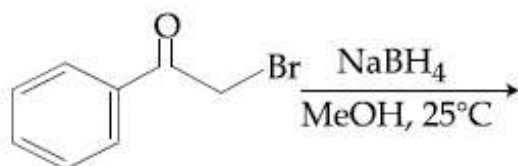

Options :

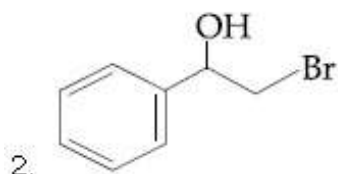
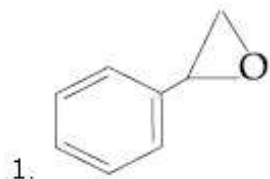

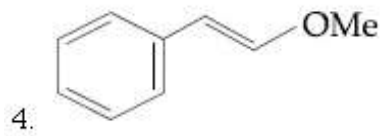
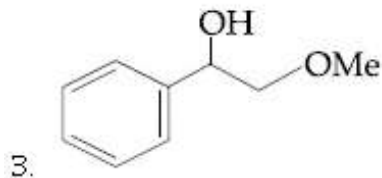

Question Number : 36 Question Type : MCQ Option Shuffling : Yes Display Question Number : Yes Single Line Question Option : No Option Orientation : Vertical

Correct Marks : 4 Wrong Marks : 1

નીચેની પ્રક્રિયાની મુખ્ય નીપજ કઈ?

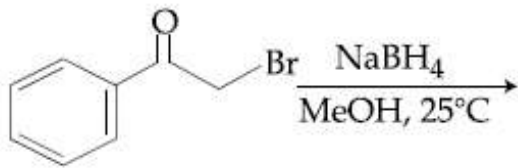

Options :

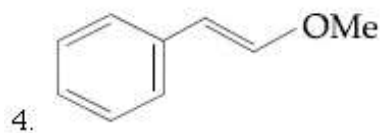
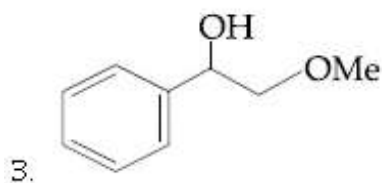
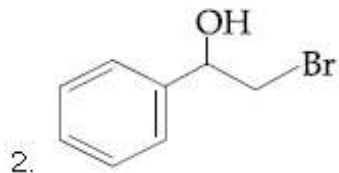
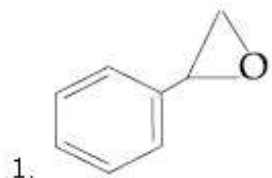

Question Number : 37 Question Type : MCQ Option Shuffling : Yes Display Question Number : Yes Single Line Question Option : No Option Orientation : Vertical

Correct Marks : 4 Wrong Marks : 1

Which of the following amines can be prepared by Gabriel phthalimide reaction ?

Options :



1. neo-pentylamine
2. n-butylamine
3. t-butylamine
4. triethylamine

Question Number : 37 Question Type : MCQ Option Shuffling : Yes Display Question Number : Yes Single Line Question Option : No Option Orientation : Vertical

Correct Marks : 4 Wrong Marks : 1

निम्न में से कौन सा ऐमीन गैब्रिएल थैलिमाइड अभिक्रिया द्वारा तैयार किया जा सकता है ?

Options :

1. निओपेन्टिलऐमीन
2. n-ब्यूटिलऐमीन
3. t-ब्यूटिलऐमीन
4. ट्राईएथिलऐमीन

Question Number : 37 Question Type : MCQ Option Shuffling : Yes Display Question Number : Yes Single Line Question Option : No Option Orientation : Vertical

Correct Marks : 4 Wrong Marks : 1

ग्रेभियल थैलिमाइड प्रक्रिया द्वारा नीचेना मांथी क्यो अमार्शन बने छे ?

Options :

1. नीओ-पेन्टार्शलअमार्शन
2. n-ब्यूटार्शलअमार्शन
3. t-ब्यूटार्शलअमार्शन
4. ट्रायर्थार्शलअमार्शन

Question Number : 38 Question Type : MCQ Option Shuffling : Yes Display Question Number : Yes Single Line Question Option : No Option Orientation : Vertical

Correct Marks : 4 Wrong Marks : 1

The IUPAC name of the following compound is :

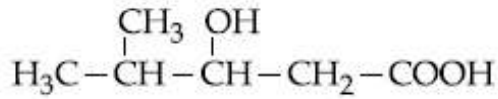

Options :

1. 3-Hydroxy-4-methylpentanoic acid
2. 4-Methyl-3-hydroxypentanoic acid
3. 4,4-Dimethyl-3-hydroxybutanoic acid
4. 2-Methyl-3-hydroxypentan-5-oic acid

Question Number : 38 Question Type : MCQ Option Shuffling : Yes Display Question Number : Yes Single Line Question Option : No Option Orientation : Vertical

Correct Marks : 4 Wrong Marks : 1

निम्न यौगिक का आई.यू.पी.ए.सी. (IUPAC) नाम है :

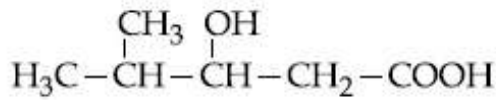

Options :

1. 3-हाइड्रॉक्सी-4-मेथिलपेन्टानोइक एसिड
2. 4-मेथिल-3-हाइड्रॉक्सीपेन्टेनोइक एसिड
3. 4,4-डाइमेथिल-3-हाइड्रॉक्सीब्यूटेनोइक एसिड
4. 2-मेथिल-3-हाइड्रॉक्सीपेन्टेन-5-ओइक एसिड

Question Number : 38 Question Type : MCQ Option Shuffling : Yes Display Question Number : Yes Single Line Question Option : No Option Orientation : Vertical

Correct Marks : 4 Wrong Marks : 1

नीचेना संयोजननुं IUPAC नाम आपो.

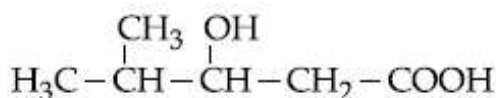

Options :

1. 3-हाइड्रॉक्सी-4-मेथिलपेन्टानोइक एसिड

2. 4-મિથાઈલ-3-હાઈડ્રોક્સીપેન્ટાનોઈક એસિડ
3. 4,4-ડાયમિથાઈલ-3-હાઈડ્રોક્સીબ્યુટાનોઈક એસિડ
4. 2-મિથાઈલ-3-હાઈડ્રોક્સીપેન્ટેન-5-ઓઈક એસિડ

Question Number : 39 Question Type : MCQ Option Shuffling : Yes Display Question Number : Yes Single Line Question Option : No Option Orientation : Vertical

Correct Marks : 4 Wrong Marks : 1

An organic compound 'X' showing the following solubility profile is :

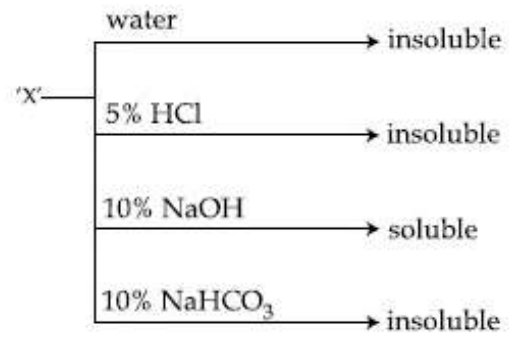

- Options :
1. Oleic acid
  2. m-Cresol
  3. o-Toluidine
  4. Benzamide

Question Number : 39 Question Type : MCQ Option Shuffling : Yes Display Question Number : Yes Single Line Question Option : No Option Orientation : Vertical

Correct Marks : 4 Wrong Marks : 1

एक कार्बनिक यौगिक 'X' जो निम्न विलेयता की रूपरेखा प्रदर्शित करता है, होगा :

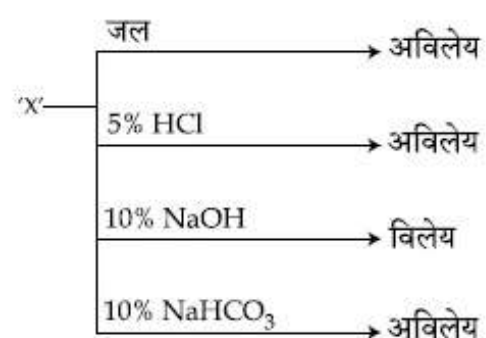

- Options :
1. ऑलेइક અમ્લ

2. m-ક્રેસોલ
3. o-ટાલુડીન
4. બેંજામાઇડ

Question Number : 39 Question Type : MCQ Option Shuffling : Yes Display Question Number : Yes Single Line Question Option : No Option Orientation : Vertical

Correct Marks : 4 Wrong Marks : 1

એક કાર્બનિક સંયોજન 'X' નીચે મુજબની દ્રાવ્યતા રૂપરેખા દર્શાવે છે. 'X' એ :

'X'	પાણી	અદ્રાવ્ય
	5% HCl	અદ્રાવ્ય
	10% NaOH	દ્રાવ્ય
	10% NaHCO <sub>3</sub>	અદ્રાવ્ય

Options :

1. ઓલીક એસિડ
2. m-ક્રેસોલ
3. o-ટોલ્યુડીન
4. બેન્ઝામાઇડ

Question Number : 40 Question Type : MCQ Option Shuffling : Yes Display Question Number : Yes Single Line Question Option : No Option Orientation : Vertical

Correct Marks : 4 Wrong Marks : 1

In the following compounds, the decreasing order of basic strength will be :

Options :

1.  $(C_2H_5)_2NH > C_2H_5NH_2 > NH_3$
2.  $NH_3 > C_2H_5NH_2 > (C_2H_5)_2NH$
3.  $(C_2H_5)_2NH > NH_3 > C_2H_5NH_2$
4.  $C_2H_5NH_2 > NH_3 > (C_2H_5)_2NH$

Question Number : 40 Question Type : MCQ Option Shuffling : Yes Display Question Number : Yes Single Line Question Option : No Option Orientation : Vertical

Correct Marks : 4 Wrong Marks : 1

निम्नलिखित यौगिकों में, क्षारीय सामर्थ्य का घटता क्रम होगा :

Options :

1.  $(C_2H_5)_2NH > C_2H_5NH_2 > NH_3$
2.  $NH_3 > C_2H_5NH_2 > (C_2H_5)_2NH$
3.  $(C_2H_5)_2NH > NH_3 > C_2H_5NH_2$
4.  $C_2H_5NH_2 > NH_3 > (C_2H_5)_2NH$

Question Number : 40 Question Type : MCQ Option Shuffling : Yes Display Question Number : Yes Single Line Question Option : No Option Orientation : Vertical

Correct Marks : 4 Wrong Marks : 1

बेजिक सामर्थ्यનો घटतो क्रम आपो :

Options :

1.  $(C_2H_5)_2NH > C_2H_5NH_2 > NH_3$
2.  $NH_3 > C_2H_5NH_2 > (C_2H_5)_2NH$
3.  $(C_2H_5)_2NH > NH_3 > C_2H_5NH_2$
4.  $C_2H_5NH_2 > NH_3 > (C_2H_5)_2NH$

Question Number : 41 Question Type : MCQ Option Shuffling : Yes Display Question Number : Yes Single Line Question Option : No Option Orientation : Vertical

Correct Marks : 4 Wrong Marks : 1

The size of the iso-electronic species  $Cl^-$ , Ar and  $Ca^{2+}$  is affected by :

Options :

1. Principal quantum number of valence shell
2. nuclear charge
3. azimuthal quantum number of valence shell

electron-electron interaction in the

4. outer orbitals

Question Number : 41 Question Type : MCQ Option Shuffling : Yes Display Question Number : Yes Single Line Question Option : No Option Orientation : Vertical

Correct Marks : 4 Wrong Marks : 1

निम्न में से किसके द्वारा समइलेक्ट्रॉनी स्पीशीज  $Cl^-$ , Ar तथा  $Ca^{2+}$  का आकार प्रभावित होगा :

Options :

1. संयोजकता कोश की मुख्य क्वान्टम संख्या
2. नाभिकीय आवेश
3. संयोजकता कोश की एजीमूथल क्वान्टम संख्या
4. बाह्य कक्षकों में इलेक्ट्रॉन-इलेक्ट्रॉन अन्योन्यक्रिया

Question Number : 41 Question Type : MCQ Option Shuffling : Yes Display Question Number : Yes Single Line Question Option : No Option Orientation : Vertical

Correct Marks : 4 Wrong Marks : 1

समइलेक्ट्रॉनीय स्पीशीज  $Cl^-$ , Ar અને  $Ca^{2+}$  ના કદ પર શાના દ્વારા અસર થાય છે?

Options :

1. સંયોજકતા કોશના મુખ્ય ક્વોન્ટમ આંક
2. ન્યૂક્લીયર ભાર
3. સંયોજકતા કક્ષકનો કોણીય વેગમાન ક્વોન્ટમ આંક
4. બાહ્ય કક્ષામાં ઇલેક્ટ્રોન-ઇલેક્ટ્રોન ક્રિયા પ્રતિક્રિયા

Question Number : 42 Question Type : MCQ Option Shuffling : Yes Display Question Number : Yes Single Line Question Option : No Option Orientation : Vertical

Correct Marks : 4 Wrong Marks : 1

With respect to an ore, Ellingham diagram helps to predict the feasibility of its

Options :

1. Thermal reduction
2. Electrolysis



3. Zone refining

4. Vapour phase refining

Question Number : 42 Question Type : MCQ Option Shuffling : Yes Display Question Number : Yes Single Line Question Option : No Option Orientation : Vertical

Correct Marks : 4 Wrong Marks : 1

इलिंगम आरेख एक अयस्क के निम्न में से किसके होने की सम्भावना की प्रागुक्ति करने में हमारी मदद करता है ,

Options :

1. तापीय अपचयन

2. विद्युत अपघटन

3. जोन परिष्करण

4. वाष्प प्रावस्था परिष्करण

Question Number : 42 Question Type : MCQ Option Shuffling : Yes Display Question Number : Yes Single Line Question Option : No Option Orientation : Vertical

Correct Marks : 4 Wrong Marks : 1

काथी धातुने संबंधित अेलींगलाम रेभाहति (आकृति) तेनी कर्ष शक्यतानी आगाली करवामां महदइप छे?

Options :

1. औष्मीय रिडक्शन

2. विद्युत विभाजन

3. जोन शुद्धिकरण

4. वाष्प अवस्था शुद्धिकरण

Question Number : 43 Question Type : MCQ Option Shuffling : Yes Display Question Number : Yes Single Line Question Option : No Option Orientation : Vertical

Correct Marks : 4 Wrong Marks : 1

100 mL of a water sample contains 0.81 g of calcium bicarbonate and 0.73 g of magnesium bicarbonate. The hardness of this water sample expressed in terms of equivalents of  $\text{CaCO}_3$  is :

(molar mass of calcium bicarbonate is  $162 \text{ g mol}^{-1}$  and magnesium bicarbonate is  $146 \text{ g mol}^{-1}$ )

Options :

1. 1,000 ppm
2. 10,000 ppm
3. 100 ppm
4. 5,000 ppm

Question Number : 43 Question Type : MCQ Option Shuffling : Yes Display Question Number : Yes Single Line Question Option : No Option Orientation : Vertical

Correct Marks : 4 Wrong Marks : 1

एक जल प्रतिदर्श के 100 mL में 0.81 g कैल्शियम बाइकार्बोनेट तथा 0.73 g मैग्नीशियम बाइकार्बोनेट हैं। इस जल प्रतिदर्श की कठोरता  $\text{CaCO}_3$  के समतुल्य रूप में व्यक्त करने पर होगी :

(कैल्शियम बाइकार्बोनेट तथा मैग्नीशियम बाइकार्बोनेट के मोलर द्रव्यमान क्रमशः  $162 \text{ g mol}^{-1}$  तथा  $146 \text{ g mol}^{-1}$  हैं)

Options :

1. 1,000 ppm
2. 10,000 ppm
3. 100 ppm
4. 5,000 ppm

Question Number : 43 Question Type : MCQ Option Shuffling : Yes Display Question Number : Yes Single Line Question Option : No Option Orientation : Vertical

Correct Marks : 4 Wrong Marks : 1

100 mL પાણીના નમૂનામાં 0.81 g કેલ્શિયમ બાયકાર્બોનેટ અને 0.73 g મેગ્નેશિયમ બાયકાર્બોનેટ ધરાવે છે. પાણીના આ નમૂનાની કઠિનતા  $\text{CaCO}_3$  નાં ppm મા કેટલી ?

( $\text{CaCO}_3$  નું મોલર દળ  $162 \text{ g mol}^{-1}$  અને મેગ્નેશિયમ બાયકાર્બોનેટનું  $146 \text{ g mol}^{-1}$  છે.)

Options :

- 1,000 ppm
- 10,000 ppm
- 100 ppm
- 5,000 ppm

Question Number : 44 Question Type : MCQ Option Shuffling : Yes Display Question Number : Yes Single Line Question Option : No Option Orientation : Vertical

Correct Marks : 4 Wrong Marks : 1

The correct order of hydration enthalpies of alkali metal ions is :

Options :

- $\text{Li}^+ > \text{Na}^+ > \text{K}^+ > \text{Rb}^+ > \text{Cs}^+$
- $\text{Li}^+ > \text{Na}^+ > \text{K}^+ > \text{Cs}^+ > \text{Rb}^+$
- $\text{Na}^+ > \text{Li}^+ > \text{K}^+ > \text{Rb}^+ > \text{Cs}^+$
- $\text{Na}^+ > \text{Li}^+ > \text{K}^+ > \text{Cs}^+ > \text{Rb}^+$

Question Number : 44 Question Type : MCQ Option Shuffling : Yes Display Question Number : Yes Single Line Question Option : No Option Orientation : Vertical

Correct Marks : 4 Wrong Marks : 1

ક્ષાર ધાતુ આયનોં કે જલયોજન ઇન્થેલ્પી કા સહી ક્રમ હૈ :

Options :

- $\text{Li}^+ > \text{Na}^+ > \text{K}^+ > \text{Rb}^+ > \text{Cs}^+$
- $\text{Li}^+ > \text{Na}^+ > \text{K}^+ > \text{Cs}^+ > \text{Rb}^+$
- $\text{Na}^+ > \text{Li}^+ > \text{K}^+ > \text{Rb}^+ > \text{Cs}^+$



Question Number : 44 Question Type : MCQ Option Shuffling : Yes Display Question Number : Yes Single Line Question Option : No Option Orientation : Vertical

Correct Marks : 4 Wrong Marks : 1

આલ્કલી ધાતુ આયનોનો જલયોજન એન્ટાપીઓનો સાથો

ક્રમાંક છે :

Options :

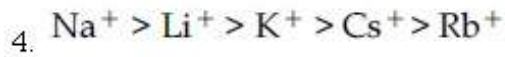
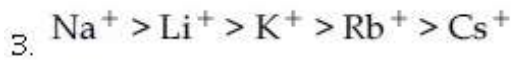
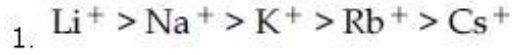

Question Number : 45 Question Type : MCQ Option Shuffling : Yes Display Question Number : Yes Single Line Question Option : No Option Orientation : Vertical

Correct Marks : 4 Wrong Marks : 1

Diborane ( $\text{B}_2\text{H}_6$ ) reacts independently with

$\text{O}_2$  and  $\text{H}_2\text{O}$  to produce, respectively :

Options :

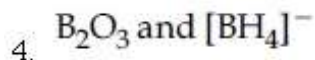
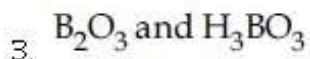
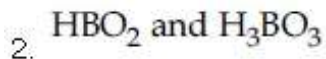
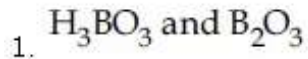

Question Number : 45 Question Type : MCQ Option Shuffling : Yes Display Question Number : Yes Single Line Question Option : No Option Orientation : Vertical

Correct Marks : 4 Wrong Marks : 1

डाइबोरेन ( $\text{B}_2\text{H}_6$ ),  $\text{O}_2$  तथा  $\text{H}_2\text{O}$  के साथ स्वतंत्र रूप

से अभिक्रिया करके क्रमशः उत्पादित करती है :

Options :

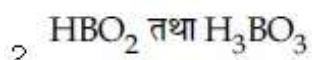
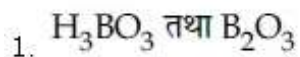

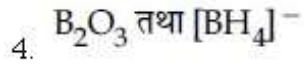
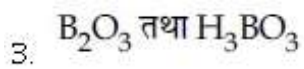

Question Number : 45 Question Type : MCQ Option Shuffling : Yes Display Question Number : Yes Single Line Question Option : No Option Orientation : Vertical

Correct Marks : 4 Wrong Marks : 1

ડાયબોરેન ( $B_2H_6$ ) અનુક્રમે  $O_2$  અને  $H_2O$  સાથે સ્વતંત્ર રીતે પ્રક્રિયા કરી શું બનાવે?

Options :

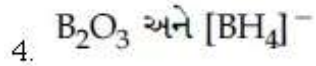
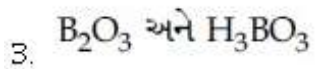
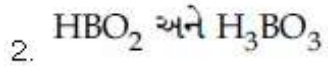
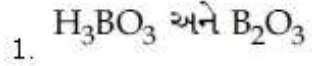

Question Number : 46 Question Type : MCQ Option Shuffling : Yes Display Question Number : Yes Single Line Question Option : No Option Orientation : Vertical

Correct Marks : 4 Wrong Marks : 1

The lanthanide ion that would show colour is :

Options :

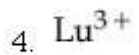
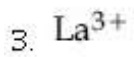
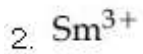

Question Number : 46 Question Type : MCQ Option Shuffling : Yes Display Question Number : Yes Single Line Question Option : No Option Orientation : Vertical

Correct Marks : 4 Wrong Marks : 1

વહ લૅન્થનાયડ આયન જો રંગ પ્રદર્શિત કરેગા, હૈ :

Options :

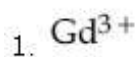

2.  $\text{Sm}^{3+}$

3.  $\text{La}^{3+}$

4.  $\text{Lu}^{3+}$

Question Number : 46 Question Type : MCQ Option Shuffling : Yes Display Question Number : Yes Single Line Question Option : No Option Orientation : Vertical

Correct Marks : 4 Wrong Marks : 1

લેન્થેનાઈડ આયન કે જે રંગ દર્શાવે છે તે :

Options :

1.  $\text{Gd}^{3+}$

2.  $\text{Sm}^{3+}$

3.  $\text{La}^{3+}$

4.  $\text{Lu}^{3+}$

Question Number : 47 Question Type : MCQ Option Shuffling : Yes Display Question Number : Yes Single Line Question Option : No Option Orientation : Vertical

Correct Marks : 4 Wrong Marks : 1

The following ligand is :

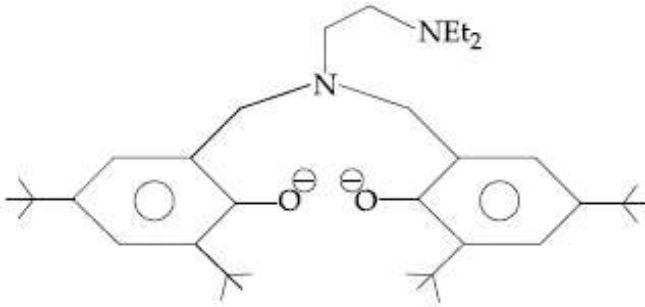

Options :

1. bidentate

2. tridentate

3. tetradentate

4. hexadentate

Question Number : 47 Question Type : MCQ Option Shuffling : Yes Display Question Number : Yes Single Line Question Option : No Option Orientation : Vertical

Correct Marks : 4 Wrong Marks : 1

निम्नलिखित संलग्नी है :

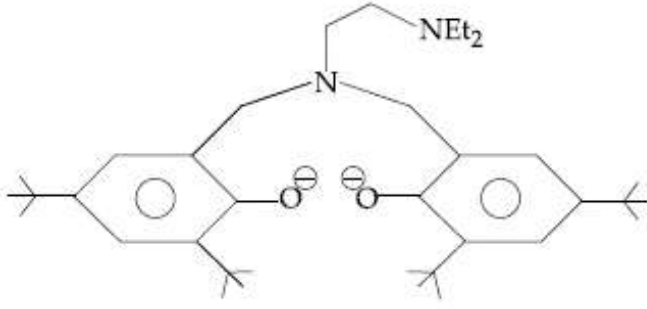

Options :

1. द्वि-दंतुर
2. त्रि-दंतुर
3. चतुरदंतुर
4. षट्-दंतुर

Question Number : 47 Question Type : MCQ Option Shuffling : Yes Display Question Number : Yes Single Line Question Option : No Option Orientation : Vertical

Correct Marks : 4 Wrong Marks : 1

नीचे आपेसुं लीगान्ड छे :

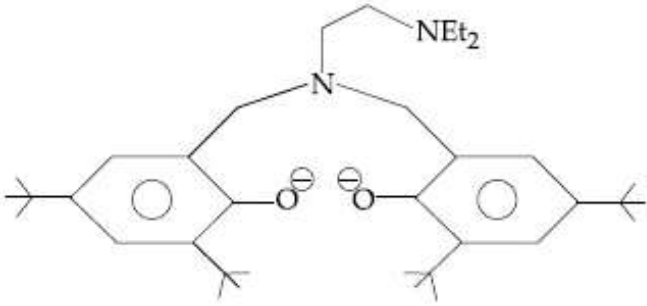

Options :

1. द्विदंतिय
2. त्रिदंतिय
3. चतुषदंतिय
4. षष्टदंतिय

Question Number : 48 Question Type : MCQ Option Shuffling : Yes Display Question Number : Yes Single Line Question Option : No Option Orientation : Vertical

Correct Marks : 4 Wrong Marks : 1



The correct order of the spin-only magnetic moment of metal ions in the following low-spin complexes,  $[V(CN)_6]^{4-}$ ,  $[Fe(CN)_6]^{4-}$ ,  $[Ru(NH_3)_6]^{3+}$ , and  $[Cr(NH_3)_6]^{2+}$ , is :

Options :

1.  $V^{2+} > Cr^{2+} > Ru^{3+} > Fe^{2+}$
2.  $V^{2+} > Ru^{3+} > Cr^{2+} > Fe^{2+}$
3.  $Cr^{2+} > Ru^{3+} > Fe^{2+} > V^{2+}$
4.  $Cr^{2+} > V^{2+} > Ru^{3+} > Fe^{2+}$

Question Number : 48 Question Type : MCQ Option Shuffling : Yes Display Question Number : Yes Single Line Question Option : No Option Orientation : Vertical

Correct Marks : 4 Wrong Marks : 1

दिये गये निम्न-प्रचक्रण संकरो  $[V(CN)_6]^{4-}$ ,  $[Fe(CN)_6]^{4-}$ ,  $[Ru(NH_3)_6]^{3+}$  तथा  $[Cr(NH_3)_6]^{2+}$  में धातु आयनों के प्रचक्रण मात्र चुम्बकीय आघूर्णों का सही क्रम है :

Options :

1.  $V^{2+} > Cr^{2+} > Ru^{3+} > Fe^{2+}$
2.  $V^{2+} > Ru^{3+} > Cr^{2+} > Fe^{2+}$
3.  $Cr^{2+} > Ru^{3+} > Fe^{2+} > V^{2+}$
4.  $Cr^{2+} > V^{2+} > Ru^{3+} > Fe^{2+}$

Question Number : 48 Question Type : MCQ Option Shuffling : Yes Display Question Number : Yes Single Line Question Option : No Option Orientation : Vertical

Correct Marks : 4 Wrong Marks : 1

नीचा स्पीन धरावता संकीर्ण  $[V(CN)_6]^{4-}$ ,  $[Fe(CN)_6]^{4-}$ ,  $[Ru(NH_3)_6]^{3+}$  अने  $[Cr(NH_3)_6]^{2+}$  ने ध्यानमां लो. तेओमा धातु आयनोनो इक्त स्पीन चुंबकीय थाकमात्रानो साथो क्मांक छे :

Options :

1.  $V^{2+} > Cr^{2+} > Ru^{3+} > Fe^{2+}$
2.  $V^{2+} > Ru^{3+} > Cr^{2+} > Fe^{2+}$

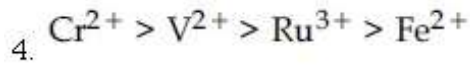
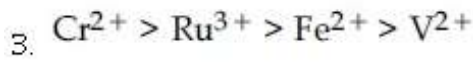

Question Number : 49 Question Type : MCQ Option Shuffling : Yes Display Question Number : Yes Single Line Question Option : No Option Orientation : Vertical

Correct Marks : 4 Wrong Marks : 1

Which is wrong with respect to our responsibility as a human being to protect our environment ?

Options :

1. Setting up compost tin in gardens.

2. Using plastic bags.

3. Restricting the use of vehicles

4. Avoiding the use of floodlighted facilities.

Question Number : 49 Question Type : MCQ Option Shuffling : Yes Display Question Number : Yes Single Line Question Option : No Option Orientation : Vertical

Correct Marks : 4 Wrong Marks : 1

मनुष्यता के नाते हमारे पर्यावरण के संरक्षण के लिए हमारी जिम्मेदारियों के संदर्भ में क्या गलत है ?

Options :

1. बगीचों में कम्पोस्ट टिन लगाना

2. प्लास्टिक बैगों का प्रयोग करना

3. वाहनों के प्रयोग पर प्रतिबन्ध लगाना

4. पूर-प्रदीप्ति सुविधाओं के प्रयोग से बचाव रखना

Question Number : 49 Question Type : MCQ Option Shuffling : Yes Display Question Number : Yes Single Line Question Option : No Option Orientation : Vertical

Correct Marks : 4 Wrong Marks : 1

मनुष्य तरीके पर्यावरणनुं रक्षा करवानी आपणी जवाबदारीना संदर्भमा क्युं भोटुं छे ?

Options :

1. अगीयाओमां भातरना ऽब्बा गोठववा

2. प्लास्टिक थेलीओनो वपराश

3. चालनोनो नियंत्रित उपयोग

4. तीव्र प्रकाशित (floodlighted) सुविधाओनो उपयोग टाणवो.

Question Number : 50 Question Type : MCQ Option Shuffling : Yes Display Question Number : Yes Single Line Question Option : No Option Orientation : Vertical

Correct Marks : 4 Wrong Marks : 1

Assertion : Ozone is destroyed by CFCs in the upper stratosphere.

Reason : Ozone holes increase the amount of UV radiation reaching the earth.

Options :

1. Assertion and reason are correct, but the reason is not the explanation for the assertion.

2. Assertion is false, but the reason is correct.

3. Assertion and reason are both correct, and the reason is the correct explanation for the assertion.

4. Assertion and reason are incorrect.

Question Number : 50 Question Type : MCQ Option Shuffling : Yes Display Question Number : Yes Single Line Question Option : No Option Orientation : Vertical

Correct Marks : 4 Wrong Marks : 1

कथन : स्ट्रेटोस्फीयर के ऊपरी भाग में CFCs द्वारा ओजोन का विनाश होता है।

कारण : ओजोनपरत छिद्रों से पृथ्वी पर पहुँचने वाले UV विकिरणों की मात्रा बढ़ती है।

Options :

1. कथन तथा कारण सही हैं परन्तु कारण, कथन की सही व्याख्या नहीं है।

2. कथन गलत है परन्तु कारण सही है।

कथन तथा कारण दोनों सही हैं और कारण,

3. कथन की सही व्याख्या करता है।

4. कथन तथा कारण दोनों गलत हैं।

Question Number : 50 Question Type : MCQ Option Shuffling : Yes Display Question Number : Yes Single Line Question Option : No Option Orientation : Vertical

Correct Marks : 4 Wrong Marks : 1

અભિધારણા : ઉપરના સમતાપી આવરણમાં CFCs દ્વારા ઓઝોન નાશ પામે છે.

કારણ : ઓઝોનના ગાબડાં પારજંબલી વિકિરણના જથ્થાને પૃથ્વી સુધી પહોંચાડવામા વધારો કરે છે.

Options :

અભિધારણા અને કારણ સાચા છે, પરંતુ કારણએ અભિધારણાની સમજૂતી નથી.

1. અભિધારણા ખોટી છે, પરંતુ કારણ સાચું છે.

અભિધારણા અને કારણ બંને સાચા છે અને કારણ એ અભિધારણા માટેની સાચી સમજૂતી છે.

4. અભિધારણા અને કારણ બંને સાચા નથી.

Question Number : 51 Question Type : MCQ Option Shuffling : Yes Display Question Number : Yes Single Line Question Option : No Option Orientation : Vertical

Correct Marks : 4 Wrong Marks : 1

In order to oxidise a mixture of one mole of each of  $\text{FeC}_2\text{O}_4$ ,  $\text{Fe}_2(\text{C}_2\text{O}_4)_3$ ,  $\text{FeSO}_4$  and  $\text{Fe}_2(\text{SO}_4)_3$  in acidic medium, the number of moles of  $\text{KMnO}_4$  required is :

Options :

1. 1

2. 1.5

3. 2

4. 3

Question Number : 51 Question Type : MCQ Option Shuffling : Yes Display Question Number : Yes Single Line Question Option : No Option Orientation : Vertical

Correct Marks : 4 Wrong Marks : 1

अम्लीय माध्यम में,  $\text{FeC}_2\text{O}_4$ ,  $\text{Fe}_2(\text{C}_2\text{O}_4)_3$ ,  $\text{FeSO}_4$  तथा  $\text{Fe}_2(\text{SO}_4)_3$  प्रत्येक के एक मोल मिश्रण को उपचयित करने के लिए आवश्यक  $\text{KMnO}_4$  के मोलों की संख्या होगी :

Options :

- 1
- 1.5
- 2
- 3

Question Number : 51 Question Type : MCQ Option Shuffling : Yes Display Question Number : Yes Single Line Question Option : No Option Orientation : Vertical

Correct Marks : 4 Wrong Marks : 1

असिद्धि माध्यममां,  $\text{FeC}_2\text{O}_4$ ,  $\text{Fe}_2(\text{C}_2\text{O}_4)_3$ ,  $\text{FeSO}_4$  अने  $\text{Fe}_2(\text{SO}_4)_3$  हरेकना 1 मोल मिश्रणनुं ओक्सीडेशन करवा भाटे जरूरी  $\text{KMnO}_4$  ना मोल केटला?

Options :

- 1
- 1.5
- 2
- 3

Question Number : 52 Question Type : MCQ Option Shuffling : Yes Display Question Number : Yes Single Line Question Option : No Option Orientation : Vertical

Correct Marks : 4 Wrong Marks : 1

Element 'B' forms ccp structure and 'A' occupies half of the octahedral voids, while oxygen atoms occupy all the tetrahedral voids. The structure of bimetallic oxide is :

Options :

- $\text{A}_2\text{BO}_4$
- $\text{AB}_2\text{O}_4$



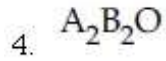
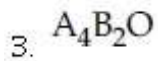

Question Number : 52 Question Type : MCQ Option Shuffling : Yes Display Question Number : Yes Single Line Question Option : No Option Orientation : Vertical

Correct Marks : 4 Wrong Marks : 1

तत्व 'B', ccp संरचना बनाता है तथा 'A' अष्टफलकीय रिक्तियों के आधे में उपस्थित है। जबकि ऑक्सीजन परमाणु सभी चतुष्फलकीय रिक्तियों में उपस्थित है। द्विधात्विक ऑक्साइड की संरचना है :

Options :

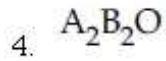
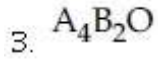
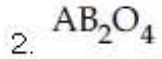
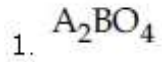

Question Number : 52 Question Type : MCQ Option Shuffling : Yes Display Question Number : Yes Single Line Question Option : No Option Orientation : Vertical

Correct Marks : 4 Wrong Marks : 1

તત્વ 'B' ccp બંધારણ બનાવે છે અને 'A' અડધા અષ્ટફલકીય છિદ્રોને રોકે છે જ્યારે સોડિયમના પરમાણુઓ તમામ ચતુષ્ફલકીય છિદ્રોને રોકે છે તો દ્વિધાત્વીય ઓક્સાઈડનું બંધારણ શોધો?

Options :

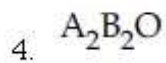
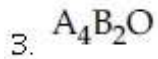
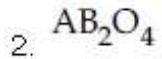
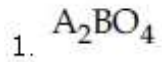

Question Number : 53 Question Type : MCQ Option Shuffling : Yes Display Question Number : Yes Single Line Question Option : No Option Orientation : Vertical

Correct Marks : 4 Wrong Marks : 1

The quantum number of four electrons are given below :

I.  $n=4, l=2, m_l=-2, m_s=-\frac{1}{2}$

II.  $n=3, l=2, m_l=1, m_s=+\frac{1}{2}$

III.  $n=4, l=1, m_l=0, m_s=+\frac{1}{2}$

IV.  $n=3, l=1, m_l=1, m_s=-\frac{1}{2}$

The correct order of their increasing energies will be :

Options :

1.  $I < II < III < IV$

2.  $I < III < II < IV$

3.  $IV < III < II < I$

4.  $IV < II < III < I$

Question Number : 53 Question Type : MCQ Option Shuffling : Yes Display Question Number : Yes Single Line Question Option : No Option Orientation : Vertical

Correct Marks : 4 Wrong Marks : 1

चार इलेक्ट्रॉनों की क्वान्टम संख्यायें नीचे दी गई हैं :

I.  $n=4, l=2, m_l=-2, m_s=-\frac{1}{2}$

II.  $n=3, l=2, m_l=1, m_s=+\frac{1}{2}$

III.  $n=4, l=1, m_l=0, m_s=+\frac{1}{2}$

IV.  $n=3, l=1, m_l=1, m_s=-\frac{1}{2}$

इनकी बढ़ती ऊर्जाओं का सही क्रम होगा :

Options :

1.  $I < II < III < IV$

2.  $I < III < II < IV$

3.  $IV < III < II < I$

4.  $IV < II < III < I$

Question Number : 53 Question Type : MCQ Option Shuffling : Yes Display Question Number : Yes Single Line Question Option : No Option Orientation : Vertical

Correct Marks : 4 Wrong Marks : 1



નીચે ચાર ઈલેક્ટ્રોનના ક્વોન્ટમ આંક આપેલા છે :

I.  $n=4, l=2, m_l = -2, m_s = -1/2$

II.  $n=3, l=2, m_l = 1, m_s = +1/2$

III.  $n=4, l=1, m_l = 0, m_s = +1/2$

IV.  $n=3, l=1, m_l = 1, m_s = -1/2$

તેમની શક્તિનો સાચો ચઢતો ક્રમ આપો.

Options :

1.  $I < II < III < IV$

2.  $I < III < II < IV$

3.  $IV < III < II < I$

4.  $IV < II < III < I$

Question Number : 54 Question Type : MCQ Option Shuffling : Yes Display Question Number : Yes Single Line Question Option : No Option Orientation : Vertical

Correct Marks : 4 Wrong Marks : 1

For silver,  $C_p (\text{J K}^{-1} \text{mol}^{-1}) = 23 + 0.01T$ . If the temperature (T) of 3 moles of silver is raised from 300 K to 1000 K at 1 atm pressure, the value of  $\Delta H$  will be close to :

Options :

1. 13 kJ

2. 21 kJ

3. 16 kJ

4. 62 kJ

Question Number : 54 Question Type : MCQ Option Shuffling : Yes Display Question Number : Yes Single Line Question Option : No Option Orientation : Vertical

Correct Marks : 4 Wrong Marks : 1

સિલ્વર કે લિષ્ટ,  $C_p (\text{J K}^{-1} \text{mol}^{-1}) = 23 + 0.01T$ . યદિ 1 atm ઢાલ પર સિલ્વર કે 3 મોલ કા તાપ (T) 300 K સે બઢકર 1000 K હો જાય તો  $\Delta H$  કા માન કિસકે નજઢીક હોગા ?

Options :

1. 13 kJ

2. 21 kJ
3. 16 kJ
4. 62 kJ

Question Number : 54 Question Type : MCQ Option Shuffling : Yes Display Question Number : Yes Single Line Question Option : No Option Orientation : Vertical

Correct Marks : 4 Wrong Marks : 1

સીલ્વર માટે,  $C_p(\text{J K}^{-1} \text{mol}^{-1}) = 23 + 0.01T$  છે.

1 વાતાવરણ દબાણે, જો સીલ્વરનાં 3 મોલનું તાપમાન (T) 300 K થી 1000 K સુધી વધારવામાં આવે તો,  $\Delta H$  ની કિંમત નીચેનામાંથી કોની નજીક છે?

Options :

1. 13 kJ
2. 21 kJ
3. 16 kJ
4. 62 kJ

Question Number : 55 Question Type : MCQ Option Shuffling : Yes Display Question Number : Yes Single Line Question Option : No Option Orientation : Vertical

Correct Marks : 4 Wrong Marks : 1

Which one of the following equations does not correctly represent the first law of thermodynamics for the given processes involving an ideal gas ? (Assume non-expansion work is zero)

Options :

1. Isothermal process :  $q = -w$
2. Cyclic process :  $q = -w$
3. Isochoric process :  $\Delta U = q$
4. Adiabatic process :  $\Delta U = -w$

Question Number : 55 Question Type : MCQ Option Shuffling : Yes Display Question Number : Yes Single Line Question Option : No Option Orientation : Vertical

Correct Marks : 4 Wrong Marks : 1

निम्न में से कौन सा समीकरण थर्मोडायनामिक्स के प्रथम सिद्धान्त को दिये गये प्रक्रमों के लिए, जिसमें आदर्श गैस है, सही रूप में प्रस्तुत नहीं करता है (मान लें कि अप्रसारण कार्य शून्य है)

Options :

1. समतापी प्रक्रम :  $q = -w$
2. चक्रीय प्रक्रम :  $q = -w$
3. समायतनिक प्रक्रम :  $\Delta U = q$
4. रुद्धोष्म प्रक्रम :  $\Delta U = -w$

Question Number : 55 Question Type : MCQ Option Shuffling : Yes Display Question Number : Yes Single Line Question Option : No Option Orientation : Vertical

Correct Marks : 4 Wrong Marks : 1

आपेली आदर्श वायुने संडोवता प्रक्रम माटे नीचेना मांथी क्यु समीकरण उष्मा गतिशास्त्रना पहिला नियमनुं सायुं निडपाइ नथी करतुं? बिनविस्तरण कार्य शून्य छे.

Options :

1. समतापी प्रक्रम :  $q = -w$
2. चक्रीय प्रक्रम :  $q = -w$
3. समकक्षीय प्रक्रम :  $\Delta U = q$
4. समोष्मी प्रक्रम :  $\Delta U = -w$

Question Number : 56 Question Type : MCQ Option Shuffling : Yes Display Question Number : Yes Single Line Question Option : No Option Orientation : Vertical

Correct Marks : 4 Wrong Marks : 1

The vapour pressures of pure liquids A and B are 400 and 600 mmHg, respectively at 298 K. On mixing the two liquids, the sum of their initial volumes is equal to the volume of the final mixture. The mole fraction of liquid B is 0.5 in the mixture. The vapour pressure of the final solution, the mole fractions of components A and B in vapour phase, respectively are :

Options :

1. 500 mmHg, 0.4, 0.6
2. 450 mmHg, 0.5, 0.5
3. 500 mmHg, 0.5, 0.5
4. 450 mmHg, 0.4, 0.6

Question Number : 56 Question Type : MCQ Option Shuffling : Yes Display Question Number : Yes Single Line Question Option : No Option Orientation : Vertical

Correct Marks : 4 Wrong Marks : 1

298 K પર શુદ્ધ દ્રવ A તથા B કે વાષ્પ દાબ ક્રમશઃ 400 તથા 600 mmHg છે. તે બંને દ્રવોને મિલકાને પર તેમને પ્રારમ્ભિક આયતનો કા યોગ તેમને અંતિમ મિશ્રણ કે આયતન કે બરાબર છે. મિશ્રણ મેં દ્રવ B કા મોલ અણુ અંશ 0.5 છે. અંતિમ વલિયન કા વાષ્પ દાબ અંવ A તથા B અવયવો કા વાષ્પ પ્રાવસ્થા મેં મોલ અણુ અંશ ક્રમશઃ હોંગે :

Options :

1. 500 mmHg, 0.4, 0.6
2. 450 mmHg, 0.5, 0.5
3. 500 mmHg, 0.5, 0.5
4. 450 mmHg, 0.4, 0.6

Question Number : 56 Question Type : MCQ Option Shuffling : Yes Display Question Number : Yes Single Line Question Option : No Option Orientation : Vertical

Correct Marks : 4 Wrong Marks : 1

298 K એ, પ્રવાહી A અને B ના વાષ્પ દબાણો અનુક્રમે 400 અને 600 mmHg છે. આ બે પ્રવાહીને ભેગા કરતા તેમના શરૂઆતના કદનો સરવાળો મિશ્રણના અંતિમ કદ કેટલો થાય છે. મિશ્રણમાં, પ્રવાહી B ના મોલ અંશ 0.5 છે. તે પરિણામી દ્રાવણનું વાષ્પદબાણ અને વાષ્પઅવસ્થામાં ઘટક A અને B ના મોલઅંશ અનુક્રમે :

Options :

1. 500 mmHg, 0.4, 0.6
2. 450 mmHg, 0.5, 0.5

3. 500 mmHg, 0.5, 0.5

4. 450 mmHg, 0.4, 0.6

Question Number : 57 Question Type : MCQ Option Shuffling : Yes Display Question Number : Yes Single Line Question Option : No Option Orientation : Vertical

Correct Marks : 4 Wrong Marks : 1

If solubility product of  $Zr_3(PO_4)_4$  is denoted by  $K_{sp}$  and its molar solubility is denoted by  $S$ , then which of the following relation between  $S$  and  $K_{sp}$  is correct ?

Options :

1.  $S = \left(\frac{K_{sp}}{144}\right)^{1/6}$

2.  $S = \left(\frac{K_{sp}}{929}\right)^{1/9}$

3.  $S = \left(\frac{K_{sp}}{6912}\right)^{1/7}$

4.  $S = \left(\frac{K_{sp}}{216}\right)^{1/7}$

Question Number : 57 Question Type : MCQ Option Shuffling : Yes Display Question Number : Yes Single Line Question Option : No Option Orientation : Vertical

Correct Marks : 4 Wrong Marks : 1

यदि  $Zr_3(PO_4)_4$  के विलेयता गुणनफल को  $K_{sp}$  द्वारा तथा इसकी मोलर विलेयता को  $S$  द्वारा अभिव्यक्त करते हों तो  $S$  तथा  $K_{sp}$  के बीच सही सम्बन्ध है :

Options :

1.  $S = \left(\frac{K_{sp}}{144}\right)^{1/6}$

2.  $S = \left(\frac{K_{sp}}{929}\right)^{1/9}$



3. 
$$S = \left( \frac{K_{sp}}{6912} \right)^{1/7}$$

4. 
$$S = \left( \frac{K_{sp}}{216} \right)^{1/7}$$

Question Number : 57 Question Type : MCQ Option Shuffling : Yes Display Question Number : Yes Single Line Question Option : No Option Orientation : Vertical

Correct Marks : 4 Wrong Marks : 1

$Zr_3(PO_4)_4$  ના દ્રાવ્યતા ગુણાકારને  $K_{sp}$  વડે સૂચિત કરેલ છે અને તેની મોલર દ્રાવ્યતાને  $S$  વડે સૂચિત કરેલ છે, તો નીચેના માંથી  $S$  અને  $K_{sp}$  વચ્ચેનો કયો સંબંધ સાચો?

Options :

1. 
$$S = \left( \frac{K_{sp}}{144} \right)^{1/6}$$

2. 
$$S = \left( \frac{K_{sp}}{929} \right)^{1/9}$$

3. 
$$S = \left( \frac{K_{sp}}{6912} \right)^{1/7}$$

4. 
$$S = \left( \frac{K_{sp}}{216} \right)^{1/7}$$

Question Number : 58 Question Type : MCQ Option Shuffling : Yes Display Question Number : Yes Single Line Question Option : No Option Orientation : Vertical

Correct Marks : 4 Wrong Marks : 1

Given that  $E_{O_2/H_2O}^{\ominus} = +1.23 \text{ V}$ ;

$E_{S_2O_8^{2-}/SO_4^{2-}}^{\ominus} = 2.05 \text{ V}$

$E_{Br_2/Br^-}^{\ominus} = +1.09 \text{ V}$ ;

$E_{Au^{3+}/Au}^{\ominus} = +1.4 \text{ V}$

The strongest oxidizing agent is :

Options :



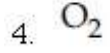
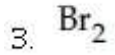
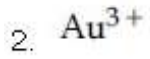
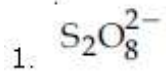

Question Number : 58 Question Type : MCQ Option Shuffling : Yes Display Question Number : Yes Single Line Question Option : No Option Orientation : Vertical

Correct Marks : 4 Wrong Marks : 1

दिया गया है,  $E_{O_2/H_2O}^\ominus = +1.23 \text{ V}$ ;

$$E_{S_2O_8^{2-}/SO_4^{2-}}^\ominus = 2.05 \text{ V}$$

$$E_{Br_2/Br^-}^\ominus = +1.09 \text{ V};$$

$$E_{Au^{3+}/Au}^\ominus = +1.4 \text{ V}$$

प्रबलतम उपचायक है :

Options :

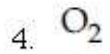
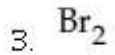
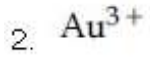
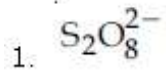

Question Number : 58 Question Type : MCQ Option Shuffling : Yes Display Question Number : Yes Single Line Question Option : No Option Orientation : Vertical

Correct Marks : 4 Wrong Marks : 1

$$E_{O_2/H_2O}^\ominus = +1.23 \text{ V};$$

$$E_{S_2O_8^{2-}/SO_4^{2-}}^\ominus = 2.05 \text{ V}$$

$$E_{Br_2/Br^-}^\ominus = +1.09 \text{ V};$$

$$E_{Au^{3+}/Au}^\ominus = +1.4 \text{ V}$$
 आपेल छे. सौथी प्रबल

ओक्सीडेशनकर्ता प्रक्रियक कयो ?

Options :

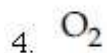
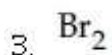
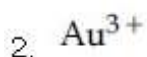
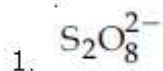

Question Number : 59 Question Type : MCQ Option Shuffling : Yes Display Question Number : Yes Single Line Question Option : No Option Orientation : Vertical

Correct Marks : 4 Wrong Marks : 1

For the reaction  $2A + B \rightarrow C$ , the values of initial rate at different reactant concentrations are given in the table below.

The rate law for the reaction is :

[A] ( $\text{mol L}^{-1}$ )	[B] ( $\text{mol L}^{-1}$ )	Initial Rate ( $\text{mol L}^{-1}\text{s}^{-1}$ )
0.05	0.05	0.045
0.10	0.05	0.090
0.20	0.10	0.72

Options :

1.  $\text{Rate} = k[A][B]$

2.  $\text{Rate} = k[A]^2[B]$

3.  $\text{Rate} = k[A][B]^2$

4.  $\text{Rate} = k[A]^2[B]^2$

Question Number : 59 Question Type : MCQ Option Shuffling : Yes Display Question Number : Yes Single Line Question Option : No Option Orientation : Vertical

Correct Marks : 4 Wrong Marks : 1

અભિક્રિયા  $2A + B \rightarrow C$  કે લિયે, અભિકારકોં કી વિભિન્ન સાન્દ્રતાઓં પર પ્રારમ્ભિક દર કે માન નીચે દી ગઈ તાલિકા મેં દિયે ગયે હેં। અભિક્રિયા કે લિયે દર નિયમ હોગા :

[A] (mol L <sup>-1</sup> )	[B] (mol L <sup>-1</sup> )	પ્રારમ્ભિક દર (mol L <sup>-1</sup> s <sup>-1</sup> )
0.05	0.05	0.045
0.10	0.05	0.090
0.20	0.10	0.72

Options :

1. દર =  $k[A][B]$
2. દર =  $k[A]^2[B]$
3. દર =  $k[A][B]^2$
4. દર =  $k[A]^2[B]^2$

Question Number : 59 Question Type : MCQ Option Shuffling : Yes Display Question Number : Yes Single Line Question Option : No Option Orientation : Vertical

Correct Marks : 4 Wrong Marks : 1

આપેલી પ્રક્રિયા  $2A + B \rightarrow C$  માટે, નીચેના ટેબલમાં પ્રક્રિયકની જૂદી-જૂદી સાંદ્રતા માટે પ્રારંભિક દરની કિંમતો આપેલી છે. પ્રક્રિયા માટે વેગનો નિયમ છે.

[A] (mol L <sup>-1</sup> )	[B] (mol L <sup>-1</sup> )	શરૂઆતની દર (mol L <sup>-1</sup> s <sup>-1</sup> )
0.05	0.05	0.045
0.10	0.05	0.090
0.20	0.10	0.72

Options :

1. વેગ =  $k[A][B]$
2. વેગ =  $k[A]^2[B]$
3. વેગ =  $k[A][B]^2$
4. વેગ =  $k[A]^2[B]^2$

Question Number : 60 Question Type : MCQ Option Shuffling : Yes Display Question Number : Yes Single Line Question Option : No Option Orientation : Vertical

Correct Marks : 4 Wrong Marks : 1

Adsorption of a gas follows Freundlich adsorption isotherm.  $x$  is the mass of the gas adsorbed on mass  $m$  of the adsorbent.

The plot of  $\log \frac{x}{m}$  versus  $\log p$  is shown in

the given graph.  $\frac{x}{m}$  is proportional to :

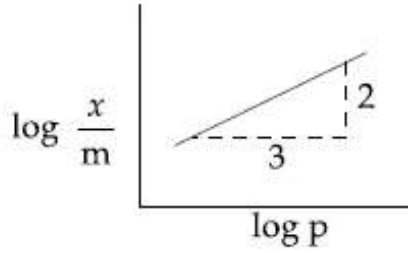

Options :

1.  $p^2$
2.  $p^{3/2}$
3.  $p^{2/3}$
4.  $p^3$

Question Number : 60 Question Type : MCQ Option Shuffling : Yes Display Question Number : Yes Single Line Question Option : No Option Orientation : Vertical

Correct Marks : 4 Wrong Marks : 1

एक गैस का अधिशोषण, फ्रायन्डलिक अधिशोषण समताप का पालन करता है। अधिशोषक के  $m$  द्रव्यमान

पर अधिशोषित गैस का द्रव्यमान  $x$  है।  $\log \frac{x}{m}$  के

विरुद्ध  $\log p$  का प्लॉट दिये गये ग्राफ में दर्शाया गया

है।  $\frac{x}{m}$  जिसके अनुपातिक है, वह है :

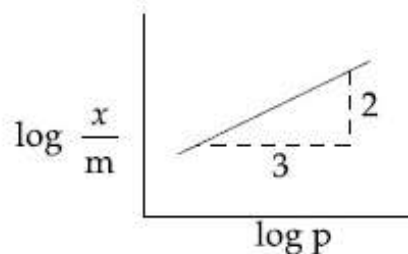

Options :

1.  $p^2$
2.  $p^{3/2}$
3.  $p^{2/3}$
4.  $p^3$

Question Number : 60 Question Type : MCQ Option Shuffling : Yes Display Question Number : Yes Single Line Question Option : No Option Orientation : Vertical

Correct Marks : 4 Wrong Marks : 1

એક વાયુનું અધિશોષણ કૂંડલીય અધિશોષણ સમતાપીને અનુસરે છે.  $m$  દળ ધરાવતા અધિશોષણ પર  $x$  દળ

ધરાવતા વાયુનું અધિશોષણ થાય છે.  $\log \frac{x}{m}$  વિરુદ્ધ

$\log p$  નો આલેખ નીચે દર્શાવેલ છે.  $\frac{x}{m}$  એ શાને ચલે

છે :

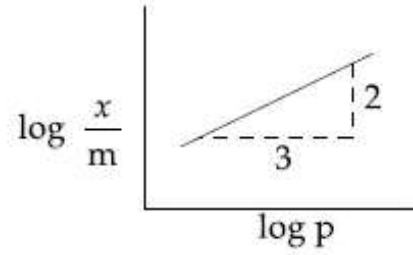

Options :

1.  $p^2$
2.  $p^{3/2}$
3.  $p^{2/3}$
4.  $p^3$

Section Id :

Section Number :

Section type :

Mandatory or Optional:

Number of Questions:

Number of Questions to be attempted:

Mathematics

416529255

3

Online

Mandatory

30

30

Section Marks:	120
Display Number Panel:	Yes
Group All Questions:	No

Sub-Section Number:	1
Sub-Section Id:	416529395
Question Shuffling Allowed :	Yes

Question Number : 61 Question Type : MCQ Option Shuffling : Yes Display Question Number : Yes Single Line Question Option : No Option Orientation : Vertical

Correct Marks : 4 Wrong Marks : 1

If  $f(x) = \log_e \left( \frac{1-x}{1+x} \right)$ ,  $|x| < 1$ , then

$f\left(\frac{2x}{1+x^2}\right)$  is equal to :

Options :

1.  $2f(x^2)$
2.  $-2f(x)$
3.  $2f(x)$
4.  $(f(x))^2$

Question Number : 61 Question Type : MCQ Option Shuffling : Yes Display Question Number : Yes Single Line Question Option : No Option Orientation : Vertical

Correct Marks : 4 Wrong Marks : 1

यदि  $f(x) = \log_e \left( \frac{1-x}{1+x} \right)$ ,  $|x| < 1$  है, तो

$f\left(\frac{2x}{1+x^2}\right)$  बराबर है :

Options :

1.  $2f(x^2)$
2.  $-2f(x)$
3.  $2f(x)$
4.  $(f(x))^2$

Question Number : 61 Question Type : MCQ Option Shuffling : Yes Display Question Number : Yes Single Line Question Option : No Option Orientation : Vertical

Correct Marks : 4 Wrong Marks : 1



Q.  $f(x) = \log_e \left( \frac{1-x}{1+x} \right), |x| < 1,$  तब

$f\left(\frac{2x}{1+x^2}\right) = \text{_____}$ .

Options :

1.  $2f(x^2)$
2.  $-2f(x)$
3.  $2f(x)$
4.  $(f(x))^2$

Question Number : 62 Question Type : MCQ Option Shuffling : Yes Display Question Number : Yes Single Line Question Option : No Option Orientation : Vertical

Correct Marks : 4 Wrong Marks : 1

If  $\alpha$  and  $\beta$  be the roots of the equation  $x^2 - 2x + 2 = 0$ , then the least value of n for

which  $\left(\frac{\alpha}{\beta}\right)^n = 1$  is :

Options :

1. 5
2. 4
3. 3
4. 2

Question Number : 62 Question Type : MCQ Option Shuffling : Yes Display Question Number : Yes Single Line Question Option : No Option Orientation : Vertical

Correct Marks : 4 Wrong Marks : 1

यदि समीकरण  $x^2 - 2x + 2 = 0$  के मूल  $\alpha$  तथा  $\beta$  हैं,

तो n का न्यूनतम मान, जिसके लिए  $\left(\frac{\alpha}{\beta}\right)^n = 1$  है,

है :

Options :

1. 5
2. 4

3. 3

4. 2

Question Number : 62 Question Type : MCQ Option Shuffling : Yes Display Question Number : Yes Single Line Question Option : No Option Orientation : Vertical

Correct Marks : 4 Wrong Marks : 1

જો  $\alpha$  અને  $\beta$  સમીકરણ  $x^2 - 2x + 2 = 0$  નાં ખીજ

હોય, તો  $\left(\frac{\alpha}{\beta}\right)^n = 1$  થાય, તે માટે  $n$  ની ન્યૂનતમ કિંમત

\_\_\_\_\_ છે.

Options :

1. 5

2. 4

3. 3

4. 2

Question Number : 63 Question Type : MCQ Option Shuffling : Yes Display Question Number : Yes Single Line Question Option : No Option Orientation : Vertical

Correct Marks : 4 Wrong Marks : 1

The sum of the solutions of the equation

$$|\sqrt{x} - 2| + \sqrt{x}(\sqrt{x} - 4) + 2 = 0, (x > 0)$$

is equal to :

Options :

1. 4

2. 9

3. 10

4. 12

Question Number : 63 Question Type : MCQ Option Shuffling : Yes Display Question Number : Yes Single Line Question Option : No Option Orientation : Vertical

Correct Marks : 4 Wrong Marks : 1

સમીકરણ

$$|\sqrt{x} - 2| + \sqrt{x}(\sqrt{x} - 4) + 2 = 0, (x > 0)$$

કે હલોં કા યોગ બરાબર હૈ :

Options :

1. 4
2. 9
3. 10
4. 12

Question Number : 63 Question Type : MCQ Option Shuffling : Yes Display Question Number : Yes Single Line Question Option : No Option Orientation : Vertical

Correct Marks : 4 Wrong Marks : 1

સમીકરણ

$$|\sqrt{x} - 2| + \sqrt{x}(\sqrt{x} - 4) + 2 = 0, (x > 0)$$

ના ઉકેલોનો સરવાળો \_\_\_\_\_ છે.

Options :

1. 4
2. 9
3. 10
4. 12

Question Number : 64 Question Type : MCQ Option Shuffling : Yes Display Question Number : Yes Single Line Question Option : No Option Orientation : Vertical

Correct Marks : 4 Wrong Marks : 1

Let  $A = \begin{pmatrix} \cos\alpha & -\sin\alpha \\ \sin\alpha & \cos\alpha \end{pmatrix}$ , ( $\alpha \in \mathbb{R}$ ) such that

$$A^{32} = \begin{pmatrix} 0 & -1 \\ 1 & 0 \end{pmatrix}. \text{ Then a value of } \alpha \text{ is :}$$

Options :

1. 0
2.  $\frac{\pi}{64}$
3.  $\frac{\pi}{32}$
4.  $\frac{\pi}{16}$

Question Number : 64 Question Type : MCQ Option Shuffling : Yes Display Question Number : Yes Single Line Question Option : No Option Orientation : Vertical

Correct Marks : 4 Wrong Marks : 1

माना  $A = \begin{pmatrix} \cos\alpha & -\sin\alpha \\ \sin\alpha & \cos\alpha \end{pmatrix}$ , ( $\alpha \in \mathbf{R}$ ) इस प्रकार

है कि  $A^{32} = \begin{pmatrix} 0 & -1 \\ 1 & 0 \end{pmatrix}$ , तो  $\alpha$  का एक मान है :

Options :

1. 0

2.  $\frac{\pi}{64}$

3.  $\frac{\pi}{32}$

4.  $\frac{\pi}{16}$

Question Number : 64 Question Type : MCQ Option Shuffling : Yes Display Question Number : Yes Single Line Question Option : No Option Orientation : Vertical

Correct Marks : 4 Wrong Marks : 1

ધારો કે  $A = \begin{pmatrix} \cos\alpha & -\sin\alpha \\ \sin\alpha & \cos\alpha \end{pmatrix}$ , ( $\alpha \in \mathbf{R}$ ) કે જેથી

$A^{32} = \begin{pmatrix} 0 & -1 \\ 1 & 0 \end{pmatrix}$ . તો  $\alpha$  ની એક કિંમત \_\_\_\_\_ છે.

Options :

1. 0

2.  $\frac{\pi}{64}$

3.  $\frac{\pi}{32}$

4.  $\frac{\pi}{16}$

Question Number : 65 Question Type : MCQ Option Shuffling : Yes Display Question Number : Yes Single Line Question Option : No Option Orientation : Vertical

Correct Marks : 4 Wrong Marks : 1

The greatest value of  $c \in \mathbb{R}$  for which the system of linear equations

$$x - cy - cz = 0$$

$$cx - y + cz = 0$$

$$cx + cy - z = 0$$

has a non-trivial solution, is :

Options :

1.  $-1$

2.  $0$

3.  $\frac{1}{2}$

4.  $2$

Question Number : 65 Question Type : MCQ Option Shuffling : Yes Display Question Number : Yes Single Line Question Option : No Option Orientation : Vertical

Correct Marks : 4 Wrong Marks : 1

$c \in \mathbb{R}$  का अधिकतम मान, जिसके लिए रैखिक समीकरण निकाय

$$x - cy - cz = 0$$

$$cx - y + cz = 0$$

$$cx + cy - z = 0$$

का एक अतुच्छ हल है, है :

Options :

1.  $-1$

2.  $0$

3.  $\frac{1}{2}$

4.  $2$

Question Number : 65 Question Type : MCQ Option Shuffling : Yes Display Question Number : Yes Single Line Question Option : No Option Orientation : Vertical

Correct Marks : 4 Wrong Marks : 1

सुरेष् समीकरण संलति

$$x - cy - cz = 0$$

$$cx - y + cz = 0$$

$$cx + cy - z = 0$$

ने योअ उकेल (non-trivial solution) भणे, ते भटे

$c \in \mathbb{R}$  नी महत्तम किंमत \_\_\_\_\_ छे.

Options :

1.  $-1$
2.  $0$
3.  $\frac{1}{2}$
4.  $2$

Question Number : 66 Question Type : MCQ Option Shuffling : Yes Display Question Number : Yes Single Line Question Option : No Option Orientation : Vertical

Correct Marks : 4 Wrong Marks : 1

All possible numbers are formed using the digits 1, 1, 2, 2, 2, 2, 3, 4, 4 taken all at a time. The number of such numbers in which the odd digits occupy even places is :

Options :

1. 160
2. 162
3. 175
4. 180

Question Number : 66 Question Type : MCQ Option Shuffling : Yes Display Question Number : Yes Single Line Question Option : No Option Orientation : Vertical

Correct Marks : 4 Wrong Marks : 1

सभी अंकों 1, 1, 2, 2, 2, 2, 3, 4, 4 को एक साथ लेकर सभी संभव संख्यायें बनाई गई हैं। इस प्रकार की संख्याओं, जिनमें विषम अंक सम स्थानों पर हैं, की संख्या है :

Options :

1. 160
2. 162
3. 175
4. 180

Question Number : 66 Question Type : MCQ Option Shuffling : Yes Display Question Number : Yes Single Line Question Option : No Option Orientation : Vertical



Correct Marks : 4 Wrong Marks : 1

1, 1, 2, 2, 2, 2, 3, 4, 4 अंकोनो अेक साथे उपयोग करी शक्य तेटली तमाम संख्याओ जनाववामां आवे छे. तो अेकी अंको जेकी स्थान पर होय तेवी केटली संख्याओ भजे?

Options :

1. 160
2. 162
3. 175
4. 180

Question Number : 67 Question Type : MCQ Option Shuffling : Yes Display Question Number : Yes Single Line Question Option : No Option Orientation : Vertical

Correct Marks : 4 Wrong Marks : 1

The sum of the co-efficients of all even degree terms in  $x$  in the expansion of

$(x + \sqrt{x^3 - 1})^6 + (x - \sqrt{x^3 - 1})^6, (x > 1)$  is equal to :

Options :

1. 24
2. 26
3. 29
4. 32

Question Number : 67 Question Type : MCQ Option Shuffling : Yes Display Question Number : Yes Single Line Question Option : No Option Orientation : Vertical

Correct Marks : 4 Wrong Marks : 1

$(x + \sqrt{x^3 - 1})^6 + (x - \sqrt{x^3 - 1})^6, (x > 1)$  के प्रसार में  $x$  के सभी समघातीय पदों के गुणांकों का योग बराबर है :

Options :

1. 24
2. 26
3. 29

4. 32

Question Number : 67 Question Type : MCQ Option Shuffling : Yes Display Question Number : Yes Single Line Question Option : No Option Orientation : Vertical

Correct Marks : 4 Wrong Marks : 1

$$(x + \sqrt{x^3 - 1})^6 + (x - \sqrt{x^3 - 1})^6, (x > 1)$$

ના વિસ્તરણમાં,  $x$  ની બેકી ઘાતવાળા તમામ પદોના સહગુણકોનો સરવાળો \_\_\_\_\_ છે.

Options :

1. 24

2. 26

3. 29

4. 32

Question Number : 68 Question Type : MCQ Option Shuffling : Yes Display Question Number : Yes Single Line Question Option : No Option Orientation : Vertical

Correct Marks : 4 Wrong Marks : 1

The sum of all natural numbers 'n' such that  $100 < n < 200$  and  $H.C.F. (91, n) > 1$  is :

Options :

1. 3203

2. 3221

3. 3121

4. 3303

Question Number : 68 Question Type : MCQ Option Shuffling : Yes Display Question Number : Yes Single Line Question Option : No Option Orientation : Vertical

Correct Marks : 4 Wrong Marks : 1

ऐसी सभी प्राकृत संख्याओं 'n', जो इस प्रकार हैं कि  $100 < n < 200$  तथा  $H.C.F. (91, n) > 1$ , का योग है :

Options :

1. 3203

2. 3221

3. 3121

4. 3303

Question Number : 68 Question Type : MCQ Option Shuffling : Yes Display Question Number : Yes Single Line Question Option : No Option Orientation : Vertical

Correct Marks : 4 Wrong Marks : 1

જે પ્રાકૃતિક સંખ્યાઓ 'n' માટે  $100 < n < 200$  અને  
ગુ.સા.અ.  $(91, n) > 1$  થાય, તેવી તમામ સંખ્યાઓનો  
સરવાળો \_\_\_\_\_ થાય.

Options :

1. 3203

2. 3221

3. 3121

4. 3303

Question Number : 69 Question Type : MCQ Option Shuffling : Yes Display Question Number : Yes Single Line Question Option : No Option Orientation : Vertical

Correct Marks : 4 Wrong Marks : 1

The sum of the series  
 $2 \cdot {}^{20}C_0 + 5 \cdot {}^{20}C_1 + 8 \cdot {}^{20}C_2 + 11 \cdot {}^{20}C_3 + \dots +$   
 $62 \cdot {}^{20}C_{20}$  is equal to :

Options :

1.  $2^{24}$

2.  $2^{25}$

3.  $2^{23}$

4.  $2^{26}$

Question Number : 69 Question Type : MCQ Option Shuffling : Yes Display Question Number : Yes Single Line Question Option : No Option Orientation : Vertical

Correct Marks : 4 Wrong Marks : 1

શ્રેણી  $2 \cdot {}^{20}C_0 + 5 \cdot {}^{20}C_1 + 8 \cdot {}^{20}C_2 + 11 \cdot {}^{20}C_3 + \dots +$   
 $62 \cdot {}^{20}C_{20}$  का योग बराबर है :

Options :

1.  $2^{24}$

2.  $2^{25}$

3.  $2^{23}$

4.  $2^{26}$

Question Number : 69 Question Type : MCQ Option Shuffling : Yes Display Question Number : Yes Single Line Question Option : No Option Orientation : Vertical

Correct Marks : 4 Wrong Marks : 1

શ્રેણી  $2 \cdot {}^{20}C_0 + 5 \cdot {}^{20}C_1 + 8 \cdot {}^{20}C_2 + 11 \cdot {}^{20}C_3 + \dots + 62 \cdot {}^{20}C_{20}$  નો સરવાળો \_\_\_\_\_ છે.

Options :

1.  $2^{24}$

2.  $2^{25}$

3.  $2^{23}$

4.  $2^{26}$

Question Number : 70 Question Type : MCQ Option Shuffling : Yes Display Question Number : Yes Single Line Question Option : No Option Orientation : Vertical

Correct Marks : 4 Wrong Marks : 1

$\lim_{x \rightarrow 0} \frac{\sin^2 x}{\sqrt{2} - \sqrt{1 + \cos x}}$  equals :

Options :

1.  $4\sqrt{2}$

2. 4

3.  $\sqrt{2}$

4.  $2\sqrt{2}$

Question Number : 70 Question Type : MCQ Option Shuffling : Yes Display Question Number : Yes Single Line Question Option : No Option Orientation : Vertical

Correct Marks : 4 Wrong Marks : 1

$\lim_{x \rightarrow 0} \frac{\sin^2 x}{\sqrt{2} - \sqrt{1 + \cos x}}$  बराबर है :

Options :

1.  $4\sqrt{2}$

2. 4

3.  $\sqrt{2}$

4.  $2\sqrt{2}$

Question Number : 70 Question Type : MCQ Option Shuffling : Yes Display Question Number : Yes Single Line Question Option : No Option Orientation : Vertical

Correct Marks : 4 Wrong Marks : 1

$$\lim_{x \rightarrow 0} \frac{\sin^2 x}{\sqrt{2} - \sqrt{1 + \cos x}} = \text{_____} .$$

Options :

1.  $4\sqrt{2}$

2. 4

3.  $\sqrt{2}$

4.  $2\sqrt{2}$

Question Number : 71 Question Type : MCQ Option Shuffling : Yes Display Question Number : Yes Single Line Question Option : No Option Orientation : Vertical

Correct Marks : 4 Wrong Marks : 1

If

$$2y = \left( \cot^{-1} \left( \frac{\sqrt{3} \cos x + \sin x}{\cos x - \sqrt{3} \sin x} \right) \right)^2, x \in \left( 0, \frac{\pi}{2} \right)$$

then  $\frac{dy}{dx}$  is equal to :

Options :

1.  $\frac{\pi}{6} - x$

2.  $\frac{\pi}{3} - x$

3.  $x - \frac{\pi}{6}$

4.  $2x - \frac{\pi}{3}$

Question Number : 71 Question Type : MCQ Option Shuffling : Yes Display Question Number : Yes Single Line Question Option : No Option Orientation : Vertical

Correct Marks : 4 Wrong Marks : 1

यदि

$$2y = \left( \cot^{-1} \left( \frac{\sqrt{3} \cos x + \sin x}{\cos x - \sqrt{3} \sin x} \right) \right)^2, x \in \left( 0, \frac{\pi}{2} \right)$$

है, तो  $\frac{dy}{dx}$  बराबर है :

Options :

1.  $\frac{\pi}{6} - x$

2.  $\frac{\pi}{3} - x$

3.  $x - \frac{\pi}{6}$

4.  $2x - \frac{\pi}{3}$

Question Number : 71 Question Type : MCQ Option Shuffling : Yes Display Question Number : Yes Single Line Question Option : No Option Orientation : Vertical

Correct Marks : 4 Wrong Marks : 1

यदि

$$2y = \left( \cot^{-1} \left( \frac{\sqrt{3} \cos x + \sin x}{\cos x - \sqrt{3} \sin x} \right) \right)^2, x \in \left( 0, \frac{\pi}{2} \right)$$

तो  $\frac{dy}{dx} =$  \_\_\_\_\_ .

Options :

1.  $\frac{\pi}{6} - x$

2.  $\frac{\pi}{3} - x$

3.  $x - \frac{\pi}{6}$

4.  $2x - \frac{\pi}{3}$

Question Number : 72 Question Type : MCQ Option Shuffling : Yes Display Question Number : Yes Single Line Question Option : No Option Orientation : Vertical

Correct Marks : 4 Wrong Marks : 1



Let  $f: [0, 2] \rightarrow \mathbb{R}$  be a twice differentiable function such that  $f''(x) > 0$ , for all  $x \in (0, 2)$ .

If  $\phi(x) = f(x) + f(2-x)$ , then  $\phi$  is :

Options :

1. increasing on  $(0, 1)$  and decreasing on  $(1, 2)$ .
2. decreasing on  $(0, 1)$  and increasing on  $(1, 2)$ .
3. increasing on  $(0, 2)$
4. decreasing on  $(0, 2)$

Question Number : 72 Question Type : MCQ Option Shuffling : Yes Display Question Number : Yes Single Line Question Option : No Option Orientation : Vertical

Correct Marks : 4 Wrong Marks : 1

$f: [0, 2] \rightarrow \mathbb{R}$  दो बार अवकलनीय फलन इस प्रकार है कि सभी  $x \in (0, 2)$  के लिए  $f''(x) > 0$  है। यदि  $\phi(x) = f(x) + f(2-x)$  है, तो  $\phi$

Options :

1.  $(0, 1)$  पर वर्धमान तथा  $(1, 2)$  पर हासमान है।
2.  $(0, 1)$  पर हासमान तथा  $(1, 2)$  पर वर्धमान है।
3.  $(0, 2)$  पर वर्धमान है।
4.  $(0, 2)$  पर हासमान है।

Question Number : 72 Question Type : MCQ Option Shuffling : Yes Display Question Number : Yes Single Line Question Option : No Option Orientation : Vertical

Correct Marks : 4 Wrong Marks : 1

ધારો કે  $f: [0, 2] \rightarrow \mathbb{R}$  એ દ્વિવિકલનીય વિધેય છે કે જેથી  $f''(x) > 0$ , પ્રત્યેક  $x \in (0, 2)$  માટે. જો  $\phi(x) = f(x) + f(2-x)$ , તો  $\phi$  એ :

Options :

1.  $(0, 1)$  પર વધતું અને  $(1, 2)$  પર ઘટતું છે.
2.  $(0, 1)$  પર ઘટતું અને  $(1, 2)$  પર વધતું છે.
3.  $(0, 2)$  પર વધતું છે.

4.  $(0, 2)$  પર ઘટતું છે.

Question Number : 73 Question Type : MCQ Option Shuffling : Yes Display Question Number : Yes Single Line Question Option : No Option Orientation : Vertical

Correct Marks : 4 Wrong Marks : 1

If  $S_1$  and  $S_2$  are respectively the sets of local minimum and local maximum points of the function,  $f(x) = 9x^4 + 12x^3 - 36x^2 + 25$ ,  $x \in \mathbb{R}$ , then :

Options :

1.  $S_1 = \{-2, 0\}; S_2 = \{1\}$

2.  $S_1 = \{-2, 1\}; S_2 = \{0\}$

3.  $S_1 = \{-1\}; S_2 = \{0, 2\}$

4.  $S_1 = \{-2\}; S_2 = \{0, 1\}$

Question Number : 73 Question Type : MCQ Option Shuffling : Yes Display Question Number : Yes Single Line Question Option : No Option Orientation : Vertical

Correct Marks : 4 Wrong Marks : 1

यदि फलन  $f(x) = 9x^4 + 12x^3 - 36x^2 + 25$ ,  $x \in \mathbb{R}$ , के स्थानीय निम्नतम तथा स्थानीय उच्चतम बिन्दुओं के समुच्चय क्रमशः  $S_1$  तथा  $S_2$  हैं, तो :

Options :

1.  $S_1 = \{-2, 0\}; S_2 = \{1\}$

2.  $S_1 = \{-2, 1\}; S_2 = \{0\}$

3.  $S_1 = \{-1\}; S_2 = \{0, 2\}$

4.  $S_1 = \{-2\}; S_2 = \{0, 1\}$

Question Number : 73 Question Type : MCQ Option Shuffling : Yes Display Question Number : Yes Single Line Question Option : No Option Orientation : Vertical

Correct Marks : 4 Wrong Marks : 1

જો વિધેય  $f(x) = 9x^4 + 12x^3 - 36x^2 + 25$ ,  $x \in \mathbb{R}$  ના સ્થાનીય ન્યૂનતમ અને સ્થાનીય મહત્તમ બિંદુઓના ગણો અનુક્રમે  $S_1$  અને  $S_2$  હોય, તો :

Options :

1.  $S_1 = \{-2, 0\}; S_2 = \{1\}$

2.  $S_1 = \{-2, 1\}; S_2 = \{0\}$

3.  $S_1 = \{-1\}; S_2 = \{0, 2\}$

4.  $S_1 = \{-2\}; S_2 = \{0, 1\}$

Question Number : 74 Question Type : MCQ Option Shuffling : Yes Display Question Number : Yes Single Line Question Option : No Option Orientation : Vertical

Correct Marks : 4 Wrong Marks : 1

$$\int \frac{\sin \frac{5x}{2}}{\sin \frac{x}{2}} dx \text{ is equal to :}$$

(where c is a constant of integration.)

Options :

1.  $x + 2 \sin x + \sin 2x + c$

2.  $x + 2 \sin x + 2 \sin 2x + c$

3.  $2x + \sin x + \sin 2x + c$

4.  $2x + \sin x + 2 \sin 2x + c$

Question Number : 74 Question Type : MCQ Option Shuffling : Yes Display Question Number : Yes Single Line Question Option : No Option Orientation : Vertical

Correct Marks : 4 Wrong Marks : 1

$$\int \frac{\sin \frac{5x}{2}}{\sin \frac{x}{2}} dx \text{ बराबर है :}$$

(जहाँ c एक समाकलन अचर है।)

Options :

1.  $x + 2 \sin x + \sin 2x + c$

2.  $x + 2 \sin x + 2 \sin 2x + c$

3.  $2x + \sin x + \sin 2x + c$

4.  $2x + \sin x + 2 \sin 2x + c$

Question Number : 74 Question Type : MCQ Option Shuffling : Yes Display Question Number : Yes Single Line Question Option : No Option Orientation : Vertical

Correct Marks : 4 Wrong Marks : 1

$$\int \frac{\sin \frac{5x}{2}}{\sin \frac{x}{2}} dx = \text{_____}.$$

(જ્યાં c એ સંકલનનો અચળાંક છે)

Options :

1.  $x + 2 \sin x + \sin 2x + c$
2.  $x + 2 \sin x + 2 \sin 2x + c$
3.  $2x + \sin x + \sin 2x + c$
4.  $2x + \sin x + 2 \sin 2x + c$

Question Number : 75 Question Type : MCQ Option Shuffling : Yes Display Question Number : Yes Single Line Question Option : No Option Orientation : Vertical

Correct Marks : 4 Wrong Marks : 1

If  $f(x) = \frac{2 - x \cos x}{2 + x \cos x}$  and  $g(x) = \log_e x$ ,

( $x > 0$ ) then the value of the integral

$$\int_{-\pi/4}^{\pi/4} g(f(x)) dx \text{ is:}$$

Options :

1.  $\log_e 2$
2.  $\log_e 3$
3.  $\log_e 1$
4.  $\log_e e$

Question Number : 75 Question Type : MCQ Option Shuffling : Yes Display Question Number : Yes Single Line Question Option : No Option Orientation : Vertical

Correct Marks : 4 Wrong Marks : 1

यदि  $f(x) = \frac{2 - x \cos x}{2 + x \cos x}$  तथा  $g(x) = \log_e x$ ,

( $x > 0$ ) हैं, तो समाकल  $\int_{-\pi/4}^{\pi/4} g(f(x)) dx$  का मान

है :

Options :

1.  $\log_e 2$

2.  $\log_e 3$

3.  $\log_e 1$

4.  $\log_e e$

Question Number : 75 Question Type : MCQ Option Shuffling : Yes Display Question Number : Yes Single Line Question Option : No Option Orientation : Vertical

Correct Marks : 4 Wrong Marks : 1

Let  $f(x) = \frac{2 - x \cos x}{2 + x \cos x}$  and  $g(x) = \log_e x$ ,

$(x > 0)$ , then  $\int_{-\pi/4}^{\pi/4} g(f(x)) dx = \dots$

Options :

1.  $\log_e 2$

2.  $\log_e 3$

3.  $\log_e 1$

4.  $\log_e e$

Question Number : 76 Question Type : MCQ Option Shuffling : Yes Display Question Number : Yes Single Line Question Option : No Option Orientation : Vertical

Correct Marks : 4 Wrong Marks : 1

The area (in sq.units) of the region  $A = \{(x, y) \in \mathbb{R} \times \mathbb{R} \mid 0 \leq x \leq 3, 0 \leq y \leq 4, y \leq x^2 + 3x\}$  is :

Options :

1. 8

2.  $\frac{26}{3}$

3.  $\frac{59}{6}$

4.  $\frac{53}{6}$

Question Number : 76 Question Type : MCQ Option Shuffling : Yes Display Question Number : Yes Single Line Question Option : No Option Orientation : Vertical

Correct Marks : 4 Wrong Marks : 1

क्षेत्र  $A = \{(x, y) \in \mathbb{R} \times \mathbb{R} \mid 0 \leq x \leq 3, 0 \leq y \leq 4, y \leq x^2 + 3x\}$  का क्षेत्रफल (वर्ग इकाइयों में) है :

Options :

1. 8

2.  $\frac{26}{3}$

3.  $\frac{59}{6}$

4.  $\frac{53}{6}$

Question Number : 76 Question Type : MCQ Option Shuffling : Yes Display Question Number : Yes Single Line Question Option : No Option Orientation : Vertical

Correct Marks : 4 Wrong Marks : 1

प्रदेश  $A = \{(x, y) \in \mathbb{R} \times \mathbb{R} \mid 0 \leq x \leq 3, 0 \leq y \leq 4, y \leq x^2 + 3x\}$  का क्षेत्रफल (वर्ग इकाइयों में) \_\_\_\_\_ है.

Options :

1. 8

2.  $\frac{26}{3}$

3.  $\frac{59}{6}$

4.  $\frac{53}{6}$

Question Number : 77 Question Type : MCQ Option Shuffling : Yes Display Question Number : Yes Single Line Question Option : No Option Orientation : Vertical

Correct Marks : 4 Wrong Marks : 1

Let  $y = y(x)$  be the solution of the differential equation,  $(x^2 + 1)^2 \frac{dy}{dx} + 2x(x^2 + 1)y = 1$  such

that  $y(0) = 0$ . If  $\sqrt{a} y(1) = \frac{\pi}{32}$ , then the value of 'a' is :

Options :

1.  $\frac{1}{16}$

2.  $\frac{1}{2}$

3. 1

4.  $\frac{1}{4}$

Question Number : 77 Question Type : MCQ Option Shuffling : Yes Display Question Number : Yes Single Line Question Option : No Option Orientation : Vertical

Correct Marks : 4 Wrong Marks : 1

माना  $y = y(x)$ , अवकल समीकरण  $(x^2 + 1)^2 \frac{dy}{dx} + 2x(x^2 + 1)y = 1$  का हल है, जबकि

$y(0) = 0$  है। यदि  $\sqrt{a} y(1) = \frac{\pi}{32}$  है, तो 'a' का

मान है :

Options :

1.  $\frac{1}{16}$

2.  $\frac{1}{2}$

3. 1

4.  $\frac{1}{4}$

Question Number : 77 Question Type : MCQ Option Shuffling : Yes Display Question Number : Yes Single Line Question Option : No Option Orientation : Vertical

Correct Marks : 4 Wrong Marks : 1



ધારો કે  $y = y(x)$  એ વિકલ સમીકરણ  
 $(x^2 + 1)^2 \frac{dy}{dx} + 2x(x^2 + 1)y = 1$  નો ઉકેલ છે તથા

$y(0) = 0$  છે. જો  $\sqrt{a} y(1) = \frac{\pi}{32}$ , તો 'a' ની કિંમત  
\_\_\_\_\_ છે.

Options :

1.  $\frac{1}{16}$

2.  $\frac{1}{2}$

3. 1

4.  $\frac{1}{4}$

Question Number : 78 Question Type : MCQ Option Shuffling : Yes Display Question Number : Yes Single Line Question Option : No Option Orientation : Vertical

Correct Marks : 4 Wrong Marks : 1

Let  $O(0, 0)$  and  $A(0, 1)$  be two fixed points.  
Then the locus of a point  $P$  such that the  
perimeter of  $\Delta AOP$  is 4, is :

Options :

1.  $9x^2 - 8y^2 + 8y = 16$

2.  $9x^2 + 8y^2 - 8y = 16$

3.  $8x^2 - 9y^2 + 9y = 18$

4.  $8x^2 + 9y^2 - 9y = 18$

Question Number : 78 Question Type : MCQ Option Shuffling : Yes Display Question Number : Yes Single Line Question Option : No Option Orientation : Vertical

Correct Marks : 4 Wrong Marks : 1

માના  $O(0, 0)$  તથા  $A(0, 1)$  દો નિશ્ચિત બિંદુ હૈ, તો  
એસે બિંદુ  $P$  જિનકે લિએ  $\Delta AOP$  કા પરિમાપ 4 હો, કા  
બિંદુપથ હૈ :

Options :

1.  $9x^2 - 8y^2 + 8y = 16$

2.  $9x^2 + 8y^2 - 8y = 16$

3.  $8x^2 - 9y^2 + 9y = 18$

4.  $8x^2 + 9y^2 - 9y = 18$

Question Number : 78 Question Type : MCQ Option Shuffling : Yes Display Question Number : Yes Single Line Question Option : No Option Orientation : Vertical

Correct Marks : 4 Wrong Marks : 1

ધારો કે  $O(0, 0)$  અને  $A(0, 1)$  બે નિશ્ચિત બિંદુઓ છે.  
તો  $\Delta AOP$  ની પરિમિતિ 4 થાય તેવા બિંદુ  $P$  નો બિંદુપથ \_\_\_\_\_ છે.

Options :

1.  $9x^2 - 8y^2 + 8y = 16$

2.  $9x^2 + 8y^2 - 8y = 16$

3.  $8x^2 - 9y^2 + 9y = 18$

4.  $8x^2 + 9y^2 - 9y = 18$

Question Number : 79 Question Type : MCQ Option Shuffling : Yes Display Question Number : Yes Single Line Question Option : No Option Orientation : Vertical

Correct Marks : 4 Wrong Marks : 1

A point on the straight line,  $3x + 5y = 15$  which is equidistant from the coordinate axes will lie only in :

Options :

1. 1<sup>st</sup>, 2<sup>nd</sup> and 4<sup>th</sup> quadrants

2. 1<sup>st</sup> quadrant

3. 1<sup>st</sup> and 2<sup>nd</sup> quadrants

4. 4<sup>th</sup> quadrant

Question Number : 79 Question Type : MCQ Option Shuffling : Yes Display Question Number : Yes Single Line Question Option : No Option Orientation : Vertical

Correct Marks : 4 Wrong Marks : 1

સરલ રેખા  $3x + 5y = 15$  પર સ્થિત એક બિંદુ, જો નિર્દેશાંક અક્ષો સે સમદૂરસ્થ છે, કેવલ સ્થિત છે :

Options :

1. प्रथम, द्वितीय तथा चतुर्थ चतुर्थांशों में
2. प्रथम चतुर्थांश में
3. प्रथम तथा द्वितीय चतुर्थांशों में
4. चतुर्थ चतुर्थांश में

Question Number : 79 Question Type : MCQ Option Shuffling : Yes Display Question Number : Yes Single Line Question Option : No Option Orientation : Vertical

Correct Marks : 4 Wrong Marks : 1

रेखा  $3x + 5y = 15$  परन्तुं अेवु बिंदु के जे अक्षोथी समान अंतरे आवेलुं छे, ते इक्त \_\_\_\_\_ .

Options :

1. प्रथम, द्वितीय अने चतुर्थ चरलामां आवशे.
2. प्रथम चरलामां आवशे.
3. प्रथम अने द्वितीय चरलामां आवशे.
4. चतुर्थ चरलामां आवशे.

Question Number : 80 Question Type : MCQ Option Shuffling : Yes Display Question Number : Yes Single Line Question Option : No Option Orientation : Vertical

Correct Marks : 4 Wrong Marks : 1

The sum of the squares of the lengths of the chords intercepted on the circle,  $x^2 + y^2 = 16$ , by the lines,  $x + y = n$ ,  $n \in \mathbb{N}$ , where  $\mathbb{N}$  is the set of all natural numbers, is :

Options :

1. 105
2. 210
3. 320
4. 160

Question Number : 80 Question Type : MCQ Option Shuffling : Yes Display Question Number : Yes Single Line Question Option : No Option Orientation : Vertical

Correct Marks : 4 Wrong Marks : 1

वृत्त  $x^2 + y^2 = 16$  पर रेखाओं  $x + y = n$ ,  $n \in \mathbb{N}$  जहाँ  $\mathbb{N}$  सभी प्राकृत संख्याओं का समुच्चय है, द्वारा काटी गई जीवाओं की लंबाइयों के वर्गों का योग है :

Options :

1. 105
2. 210
3. 320
4. 160

Question Number : 80 Question Type : MCQ Option Shuffling : Yes Display Question Number : Yes Single Line Question Option : No Option Orientation : Vertical

Correct Marks : 4 Wrong Marks : 1

रेखाओं  $x + y = n$ ,  $n \in \mathbb{N}$  (जहाँ  $\mathbb{N}$  એ પ્રાકૃતિક સંખ્યાઓનો ગણ છે), દ્વારા વર્તુળ  $x^2 + y^2 = 16$  પર અંતરિત જીવાઓની લંબાઈઓના વર્ગોનો સરવાળો \_\_\_\_\_ છે.

Options :

1. 105
2. 210
3. 320
4. 160

Question Number : 81 Question Type : MCQ Option Shuffling : Yes Display Question Number : Yes Single Line Question Option : No Option Orientation : Vertical

Correct Marks : 4 Wrong Marks : 1

The shortest distance between the line  $y = x$  and the curve  $y^2 = x - 2$  is :

Options :

1.  $\frac{11}{4\sqrt{2}}$
2.  $\frac{7}{4\sqrt{2}}$
3.  $\frac{7}{8}$

4. 2

Question Number : 81 Question Type : MCQ Option Shuffling : Yes Display Question Number : Yes Single Line Question Option : No Option Orientation : Vertical

Correct Marks : 4 Wrong Marks : 1

रेखा  $y = x$  तथा वक्र  $y^2 = x - 2$  के बीच की न्यूनतम दूरी है :

Options :

1.  $\frac{11}{4\sqrt{2}}$

2.  $\frac{7}{4\sqrt{2}}$

3.  $\frac{7}{8}$

4. 2

Question Number : 81 Question Type : MCQ Option Shuffling : Yes Display Question Number : Yes Single Line Question Option : No Option Orientation : Vertical

Correct Marks : 4 Wrong Marks : 1

रेखा  $y = x$  અને વક્ર  $y^2 = x - 2$  વચ્ચેનું ન્યૂનતમ અંતર \_\_\_\_\_ છે.

Options :

1.  $\frac{11}{4\sqrt{2}}$

2.  $\frac{7}{4\sqrt{2}}$

3.  $\frac{7}{8}$

4. 2

Question Number : 82 Question Type : MCQ Option Shuffling : Yes Display Question Number : Yes Single Line Question Option : No Option Orientation : Vertical

Correct Marks : 4 Wrong Marks : 1

If the tangents on the ellipse  $4x^2 + y^2 = 8$  at the points  $(1, 2)$  and  $(a, b)$  are perpendicular to each other, then  $a^2$  is equal to :

Options :

1.  $\frac{2}{17}$

2.  $\frac{128}{17}$

3.  $\frac{4}{17}$

4.  $\frac{64}{17}$

Question Number : 82 Question Type : MCQ Option Shuffling : Yes Display Question Number : Yes Single Line Question Option : No Option Orientation : Vertical

Correct Marks : 4 Wrong Marks : 1

यदि दीर्घवृत्त  $4x^2 + y^2 = 8$  के बिंदुओं (1, 2) तथा (a, b) पर खींची गई स्पर्शरेखाएँ परस्पर लंबवत हैं, तो  $a^2$  बराबर है :

Options :

1.  $\frac{2}{17}$

2.  $\frac{128}{17}$

3.  $\frac{4}{17}$

4.  $\frac{64}{17}$

Question Number : 82 Question Type : MCQ Option Shuffling : Yes Display Question Number : Yes Single Line Question Option : No Option Orientation : Vertical

Correct Marks : 4 Wrong Marks : 1

जे उपवलय  $4x^2 + y^2 = 8$  ना बिंदुओ (1, 2) अने (a, b) आगणना स्पर्शरेको परस्पर लंब होय, तो  $a^2 =$  \_\_\_\_\_ .

Options :

1.  $\frac{2}{17}$

2.  $\frac{128}{17}$

3.  $\frac{4}{17}$

4.  $\frac{64}{17}$

Question Number : 83 Question Type : MCQ Option Shuffling : Yes Display Question Number : Yes Single Line Question Option : No Option Orientation : Vertical

Correct Marks : 4 Wrong Marks : 1

The length of the perpendicular from the point  $(2, -1, 4)$  on the straight line,

$$\frac{x+3}{10} = \frac{y-2}{-7} = \frac{z}{1} \text{ is :}$$

Options :

1. less than 2
2. greater than 2 but less than 3
3. greater than 3 but less than 4
4. greater than 4

Question Number : 83 Question Type : MCQ Option Shuffling : Yes Display Question Number : Yes Single Line Question Option : No Option Orientation : Vertical

Correct Marks : 4 Wrong Marks : 1

बिंदु  $(2, -1, 4)$  से सरल रेखा

$$\frac{x+3}{10} = \frac{y-2}{-7} = \frac{z}{1} \text{ पर खींचे गए लंब की}$$

लंबाई :

Options :

1. 2 से कम है।
2. 2 से अधिक परंतु 3 से कम है।
3. 3 से अधिक परंतु 4 से कम है।
4. 4 से अधिक है।

Question Number : 83 Question Type : MCQ Option Shuffling : Yes Display Question Number : Yes Single Line Question Option : No Option Orientation : Vertical

Correct Marks : 4 Wrong Marks : 1



बिंदु  $(2, -1, 4)$  थी रेखा  $\frac{x+3}{10} = \frac{y-2}{-7} = \frac{z}{1}$

परना लंबनी लंबाई \_\_\_\_\_ છે.

Options :

1. 2 કરતાં ઓછી
2. 2 કરતાં વધારે પણ 3 કરતાં ઓછી
3. 3 કરતાં વધારે પણ 4 કરતાં ઓછી
4. 4 કરતાં વધારે

Question Number : 84 Question Type : MCQ Option Shuffling : Yes Display Question Number : Yes Single Line Question Option : No Option Orientation : Vertical

Correct Marks : 4 Wrong Marks : 1

The equation of a plane containing the line of intersection of the planes  $2x - y - 4 = 0$  and  $y + 2z - 4 = 0$  and passing through the point  $(1, 1, 0)$  is :

Options :

1.  $x - y - z = 0$
2.  $x + 3y + z = 4$
3.  $x - 3y - 2z = -2$
4.  $2x - z = 2$

Question Number : 84 Question Type : MCQ Option Shuffling : Yes Display Question Number : Yes Single Line Question Option : No Option Orientation : Vertical

Correct Marks : 4 Wrong Marks : 1

સમતલો  $2x - y - 4 = 0$  તથા  $y + 2z - 4 = 0$  કી પ્રતિચ્છેદન રેખા કો અંતર્વિષ્ટ કરને વાલે તથા બિંદુ  $(1, 1, 0)$  સે હોકર જાને વાલે સમતલ કા સમીકરણ હૈ :

Options :

1.  $x - y - z = 0$
2.  $x + 3y + z = 4$
3.  $x - 3y - 2z = -2$

4.  $2x - z = 2$

Question Number : 84 Question Type : MCQ Option Shuffling : Yes Display Question Number : Yes Single Line Question Option : No Option Orientation : Vertical

Correct Marks : 4 Wrong Marks : 1

સમતલો  $2x - y - 4 = 0$  અને  $y + 2z - 4 = 0$  ની છેદરેખાને સમાવતા અને બિંદુ  $(1, 1, 0)$  માંથી પસાર થતા સમતલનું સમીકરણ \_\_\_\_\_ છે.

Options :

1.  $x - y - z = 0$

2.  $x + 3y + z = 4$

3.  $x - 3y - 2z = -2$

4.  $2x - z = 2$

Question Number : 85 Question Type : MCQ Option Shuffling : Yes Display Question Number : Yes Single Line Question Option : No Option Orientation : Vertical

Correct Marks : 4 Wrong Marks : 1

The magnitude of the projection of the vector  $2\hat{i} + 3\hat{j} + \hat{k}$  on the vector perpendicular to the plane containing the vectors  $\hat{i} + \hat{j} + \hat{k}$  and  $\hat{i} + 2\hat{j} + 3\hat{k}$ , is :

Options :

1.  $3\sqrt{6}$

2.  $\frac{\sqrt{3}}{2}$

3.  $\sqrt{6}$

4.  $\sqrt{\frac{3}{2}}$

Question Number : 85 Question Type : MCQ Option Shuffling : Yes Display Question Number : Yes Single Line Question Option : No Option Orientation : Vertical

Correct Marks : 4 Wrong Marks : 1

सदिश  $2\hat{i} + 3\hat{j} + \hat{k}$  के सदिशों  $\hat{i} + \hat{j} + \hat{k}$

तथा  $\hat{i} + 2\hat{j} + 3\hat{k}$  को अंतर्विष्ट करने वाले समतल के लंबवर्तीय सदिश पर प्रक्षेप का परिमाण है :

Options :

1.  $3\sqrt{6}$

2.  $\frac{\sqrt{3}}{2}$

3.  $\sqrt{6}$

4.  $\sqrt{\frac{3}{2}}$

Question Number : 85 Question Type : MCQ Option Shuffling : Yes Display Question Number : Yes Single Line Question Option : No Option Orientation : Vertical

Correct Marks : 4 Wrong Marks : 1

सदिशो  $\hat{i} + \hat{j} + \hat{k}$  અને  $\hat{i} + 2\hat{j} + 3\hat{k}$  ને સમાવતા સમતલ ને લંબ હોય તેવા સદિશ પર, સદિશ  $2\hat{i} + 3\hat{j} + \hat{k}$  ના પ્રક્ષેપનો માન \_\_\_\_\_ છે.

Options :

1.  $3\sqrt{6}$

2.  $\frac{\sqrt{3}}{2}$

3.  $\sqrt{6}$

4.  $\sqrt{\frac{3}{2}}$

Question Number : 86 Question Type : MCQ Option Shuffling : Yes Display Question Number : Yes Single Line Question Option : No Option Orientation : Vertical

Correct Marks : 4 Wrong Marks : 1

The mean and variance of seven observations are 8 and 16, respectively. If 5 of the observations are 2, 4, 10, 12, 14, then the product of the remaining two observations is :

Options :

1. 40
2. 49
3. 45
4. 48

Question Number : 86 Question Type : MCQ Option Shuffling : Yes Display Question Number : Yes Single Line Question Option : No Option Orientation : Vertical

Correct Marks : 4 Wrong Marks : 1

सात प्रेक्षणों के माध्य तथा प्रसरण क्रमशः 8 तथा 16 हैं।  
यदि इनमें से 5 प्रेक्षण 2, 4, 10, 12, 14 हैं, तो शेष दो  
प्रेक्षणों का गुणनफल है :

Options :

1. 40
2. 49
3. 45
4. 48

Question Number : 86 Question Type : MCQ Option Shuffling : Yes Display Question Number : Yes Single Line Question Option : No Option Orientation : Vertical

Correct Marks : 4 Wrong Marks : 1

सात अवलोकनोना मध्यक अने विचरणा अनुक्रमे 8 अने  
16 छे. जे आ अवलोकनोमांनां 5 अवलोकनो  
2, 4, 10, 12, 14 छेय, तो बाकीना जे अवलोकनोना  
गुणाकार \_\_\_\_\_ छे.

Options :

1. 40
2. 49
3. 45
4. 48

Question Number : 87 Question Type : MCQ Option Shuffling : Yes Display Question Number : Yes Single Line Question Option : No Option Orientation : Vertical

Correct Marks : 4 Wrong Marks : 1

Let A and B be two non-null events such that  $A \subset B$ . Then, which of the following statements is always correct ?

Options :

1.  $P(A|B) = 1$
2.  $P(A|B) \leq P(A)$
3.  $P(A|B) \geq P(A)$
4.  $P(A|B) = P(B) - P(A)$

Question Number : 87 Question Type : MCQ Option Shuffling : Yes Display Question Number : Yes Single Line Question Option : No Option Orientation : Vertical

Correct Marks : 4 Wrong Marks : 1

माना A तथा B दो ऐसी अरिक्त (non-null) घटनायें हैं कि  $A \subset B$  है। तो निम्न में से कौन सा कथन हमेशा सही है ?

Options :

1.  $P(A|B) = 1$
2.  $P(A|B) \leq P(A)$
3.  $P(A|B) \geq P(A)$
4.  $P(A|B) = P(B) - P(A)$

Question Number : 87 Question Type : MCQ Option Shuffling : Yes Display Question Number : Yes Single Line Question Option : No Option Orientation : Vertical

Correct Marks : 4 Wrong Marks : 1

ધારો કે A અને B બે અરિક્ત ઘટનાઓ છે તથા  $A \subset B$ . તો નીચેના પૈકી કયું વિધાન હમેશાં સાચું છે ?

Options :

1.  $P(A|B) = 1$
2.  $P(A|B) \leq P(A)$
3.  $P(A|B) \geq P(A)$
4.  $P(A|B) = P(B) - P(A)$

Question Number : 88 Question Type : MCQ Option Shuffling : Yes Display Question Number : Yes Single Line Question Option : No Option Orientation : Vertical

Correct Marks : 4 Wrong Marks : 1

If  $\cos(\alpha + \beta) = \frac{3}{5}$ ,  $\sin(\alpha - \beta) = \frac{5}{13}$  and

$0 < \alpha, \beta < \frac{\pi}{4}$ , then  $\tan(2\alpha)$  is equal to :

Options :

1.  $\frac{21}{16}$

2.  $\frac{63}{16}$

3.  $\frac{63}{52}$

4.  $\frac{33}{52}$

Question Number : 88 Question Type : MCQ Option Shuffling : Yes Display Question Number : Yes Single Line Question Option : No Option Orientation : Vertical

Correct Marks : 4 Wrong Marks : 1

यदि  $\cos(\alpha + \beta) = \frac{3}{5}$ ,  $\sin(\alpha - \beta) = \frac{5}{13}$  तथा

$0 < \alpha, \beta < \frac{\pi}{4}$  हैं, तो  $\tan(2\alpha)$  बराबर है :

Options :

1.  $\frac{21}{16}$

2.  $\frac{63}{16}$

3.  $\frac{63}{52}$

4.  $\frac{33}{52}$

Question Number : 88 Question Type : MCQ Option Shuffling : Yes Display Question Number : Yes Single Line Question Option : No Option Orientation : Vertical

Correct Marks : 4 Wrong Marks : 1

१)  $\cos(\alpha + \beta) = \frac{3}{5}$ ,  $\sin(\alpha - \beta) = \frac{5}{13}$  अतः

$0 < \alpha, \beta < \frac{\pi}{4}$ , तब  $\tan(2\alpha) = \underline{\hspace{2cm}}$  .

Options :

1.  $\frac{21}{16}$

2.  $\frac{63}{16}$

3.  $\frac{63}{52}$

4.  $\frac{33}{52}$

Question Number : 89 Question Type : MCQ Option Shuffling : Yes Display Question Number : Yes Single Line Question Option : No Option Orientation : Vertical

Correct Marks : 4 Wrong Marks : 1

If  $\alpha = \cos^{-1}\left(\frac{3}{5}\right)$ ,  $\beta = \tan^{-1}\left(\frac{1}{3}\right)$ , where

$0 < \alpha, \beta < \frac{\pi}{2}$ , then  $\alpha - \beta$  is equal to :

Options :

1.  $\tan^{-1}\left(\frac{9}{14}\right)$

2.  $\sin^{-1}\left(\frac{9}{5\sqrt{10}}\right)$

3.  $\cos^{-1}\left(\frac{9}{5\sqrt{10}}\right)$

4.  $\tan^{-1}\left(\frac{9}{5\sqrt{10}}\right)$

Question Number : 89 Question Type : MCQ Option Shuffling : Yes Display Question Number : Yes Single Line Question Option : No Option Orientation : Vertical

Correct Marks : 4 Wrong Marks : 1



यदि  $\alpha = \cos^{-1}\left(\frac{3}{5}\right)$ ,  $\beta = \tan^{-1}\left(\frac{1}{3}\right)$  हैं, जहाँ

$0 < \alpha, \beta < \frac{\pi}{2}$ , तो  $\alpha - \beta$  बराबर है :

Options :

1.  $\tan^{-1}\left(\frac{9}{14}\right)$

2.  $\sin^{-1}\left(\frac{9}{5\sqrt{10}}\right)$

3.  $\cos^{-1}\left(\frac{9}{5\sqrt{10}}\right)$

4.  $\tan^{-1}\left(\frac{9}{5\sqrt{10}}\right)$

Question Number : 89 Question Type : MCQ Option Shuffling : Yes Display Question Number : Yes Single Line Question Option : No Option Orientation : Vertical

Correct Marks : 4 Wrong Marks : 1

यदि  $\alpha = \cos^{-1}\left(\frac{3}{5}\right)$ ,  $\beta = \tan^{-1}\left(\frac{1}{3}\right)$ , जहाँ

$0 < \alpha, \beta < \frac{\pi}{2}$ , तो  $\alpha - \beta =$  \_\_\_\_\_ .

Options :

1.  $\tan^{-1}\left(\frac{9}{14}\right)$

2.  $\sin^{-1}\left(\frac{9}{5\sqrt{10}}\right)$

3.  $\cos^{-1}\left(\frac{9}{5\sqrt{10}}\right)$

4.  $\tan^{-1}\left(\frac{9}{5\sqrt{10}}\right)$

Question Number : 90 Question Type : MCQ Option Shuffling : Yes Display Question Number : Yes Single Line Question Option : No Option Orientation : Vertical

Correct Marks : 4 Wrong Marks : 1

The contrapositive of the statement "If you are born in India, then you are a citizen of India", is :

Options :

1. If you are born in India, then you are not a citizen of India.
2. If you are a citizen of India, then you are born in India.
3. If you are not born in India, then you are not a citizen of India.
4. If you are not a citizen of India, then you are not born in India.

Question Number : 90 Question Type : MCQ Option Shuffling : Yes Display Question Number : Yes Single Line Question Option : No Option Orientation : Vertical

Correct Marks : 4 Wrong Marks : 1

कथन

“यदि आप भारत में जन्में हैं, तो आप भारत के एक नागरिक हैं” का प्रतिघनात्मक कथन है :

Options :

1. यदि आप भारत में जन्में हैं, तो आप भारत के नागरिक नहीं हैं।
2. यदि आप भारत के एक नागरिक हैं, तो आप भारत में जन्में हैं।
3. यदि आप भारत में नहीं जन्में, तो आप भारत के नागरिक नहीं हैं।
4. यदि आप भारत के नागरिक नहीं हैं, तो आप भारत में नहीं जन्में हैं।

Question Number : 90 Question Type : MCQ Option Shuffling : Yes Display Question Number : Yes Single Line Question Option : No Option Orientation : Vertical

Correct Marks : 4 Wrong Marks : 1

विधान “જો તમારો જન્મ ભારતમાં થયો હોય, તો તમે ભારતના નાગરિક છો”, નું સમાનાર્થી પ્રેરણ \_\_\_\_\_ છે.

Options :

1. જો તમારો જન્મ ભારતમાં થયો હોય, તો તમે ભારતના નાગરિક નથી.

2. જો તમે ભારતના નાગરિક હોવ, તો તમારો જન્મ ભારતમાં થયો છે.

3. જો તમારો જન્મ ભારતમાં નથી થયો, તો તમે ભારતના નાગરિક નથી.

4. જો તમે ભારતના નાગરિક નથી, તો તમારો જન્મ ભારતમાં નથી થયો.