

Answers & Solutions For JEE MAIN- 2015

(Code-B)

Time Durations : 3 hrs.

Maximum Marks : 360

(Chemistry, Mathematics and Physics)

Important Instructions :

1. The test is of 3 hours duration.
2. The Test Booklet consists of 90 questions. The maximum marks are 360.
3. There are three parts in the question paper A, B, C consisting of Chemistry, Mathematics and Physics having 30 questions in each part of equal weightage. Each question is allotted 4 (four) marks for each correct response.
4. Candidates will be awarded marks as stated above in Instructions No. 3 for correct response of each question. $\frac{1}{4}$ (one-fourth) marks will be deducted for indicating incorrect response of each question. No deduction from the total score will be made if no response is indicated for an item in the answer sheet.
5. There is only one correct response for each question. Filling up more than one response in each question will be treated as wrong response and marks for wrong response will be deducted accordingly as per instruction 4 above.
6. Use Blue/Black Ball Point Pen only for writing particulars/markings responses on Side-1 and Side-2 of the Answer Sheet. Use of pencil is strictly prohibited.
7. No candidate is allowed to carry any textual material, printed or written, bits of papers, pager, mobile phone, any electronic device, etc. except the Admit Card inside the examination room/hall.

- The CODE for this Booklet is B. Make sure that the CODE printed on Side-2 of the
8. Answer Sheet and also tally the serial number of the Test Booklet and Answer Sheet are the same as that on this booklet. In case of discrepancy, the candidate should immediately report the matter to the Invigilator for replacement of both the Test Booklet and the Answer

PART-A : CHEMISTRY

1. Which of the following is the energy of a possible excited state of hydrogen?

- (1) -6.8 eV (2) -3.4 eV
 (3) +6.8 eV (4) +13.6 eV

Answer (2)

Sol. Energy of excited state is negative and correspond to $n > 1$.

$$n = \sqrt{\frac{-13.6}{E_{\text{excited state}}}}$$

$$= \sqrt{\frac{-13.6}{-3.4}} = \sqrt{4} = 2$$

2. In the following sequence of reactions :

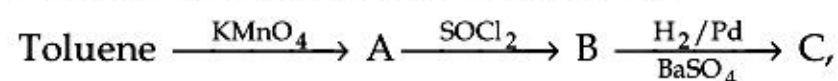

the product C is

- (1) $\text{C}_6\text{H}_5\text{CH}_3$
 (2) $\text{C}_6\text{H}_5\text{CH}_2\text{OH}$
 (3) $\text{C}_6\text{H}_5\text{CHO}$
 (4) $\text{C}_6\text{H}_5\text{COOH}$

Answer (3)

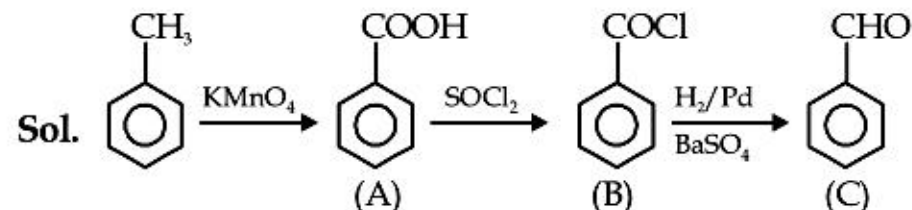

3. Which compound would give 5-keto-2-methylhexanal upon ozonolysis?

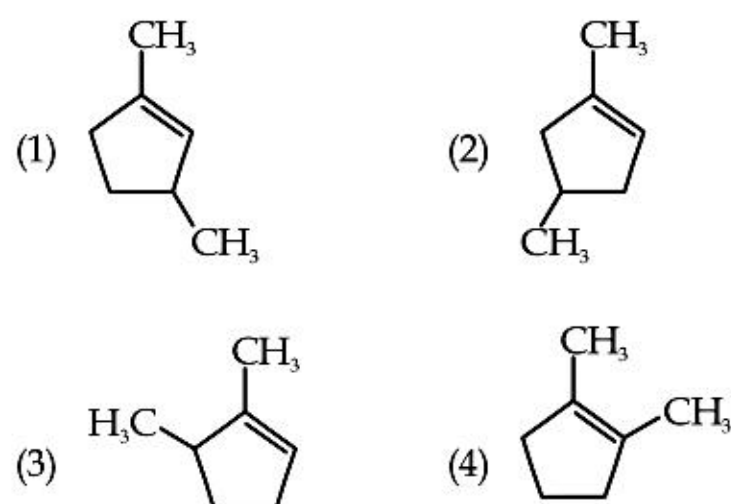

Answer (1)

Sol. 5-keto-2-methylhexanal is

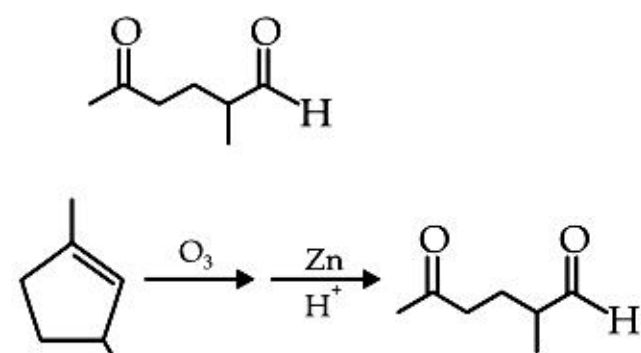

4. The ionic radii (in Å) of N^{3-} , O^{2-} and F^- are respectively

- (1) 1.36, 1.71 and 1.40
 (2) 1.71, 1.40 and 1.36
 (3) 1.71, 1.36 and 1.40
 (4) 1.36, 1.40 and 1.71

Answer (2)

Sol. Radius of N^{3-} , O^{2-} and F^- follow order



As per inequality only option (2) is correct that is 1.71 Å, 1.40 Å and 1.36 Å

5. The color of KMnO_4 is due to

- (1) d - d transition
 (2) $\text{L} \rightarrow \text{M}$ charge transfer transition
 (3) $\sigma - \sigma^*$ transition
 (4) $\text{M} \rightarrow \text{L}$ charge transfer transition

Answer (2)

Sol. Charge transfer spectra from ligand (L) to metal (M) is responsible for color of KMnO_4 .

6. **Assertion :** Nitrogen and Oxygen are the main components in the atmosphere but these do not react to form oxides of nitrogen.

Reason : The reaction between nitrogen and oxygen requires high temperature.

- (1) Both assertion and reason are correct, but the reason is not the correct explanation for the assertion
 (2) The assertion is incorrect, but the reason is correct
 (3) Both the assertion and reason are incorrect
 (4) Both assertion and reason are correct, and the reason is the correct explanation for the assertion

Answer (4)

Sol. $\text{N}_2 + \text{O}_2 \rightarrow 2\text{NO}$

Required temperature for above reaction is around 3000°C which is a quite high temperature. This reaction is observed during thunderstorm.

7. Which of the following compounds is **not** an antacid?

- (1) Cimetidine
- (2) Phenelzine
- (3) Ranitidine
- (4) Aluminium Hydroxide

Answer (2)

Sol. Phenelzine is not antacid, it is anti-depressant.

8. In the context of the Hall-Heroult process for the extraction of Al, which of the following statement is **false**?

- (1) Al_2O_3 is mixed with CaF_2 which lowers the melting point of the mixture and brings conductivity
- (2) Al^{3+} is reduced at the cathode to form Al
- (3) Na_3AlF_6 serves as the electrolyte
- (4) CO and CO_2 are produced in this process

Answer (3)

Sol. In Hall-Heroult process Al_2O_3 (molten) is electrolyte.

9. Match the catalysts to the correct processes :

Catalyst	Process
a. $TiCl_3$	(i) Wacker process
b. $PdCl_2$	(ii) Ziegler-Natta polymerization
c. $CuCl_2$	(iii) Contact process
d. V_2O_5	(iv) Deacon's process
(1) a(ii), b(i), c(iv), d(iii)	(2) a(ii), b(iii), c(iv), d(i)
(3) a(iii), b(i), c(ii), d(iv)	(4) a(iii), b(ii), c(iv), d(i)

Answer (1)

Sol. $TiCl_3$ - Ziegler Natta polymerisation

V_2O_5 - Contact process

$PdCl_2$ - Wacker process

$CuCl_2$ - Deacon's process

10. In the reaction

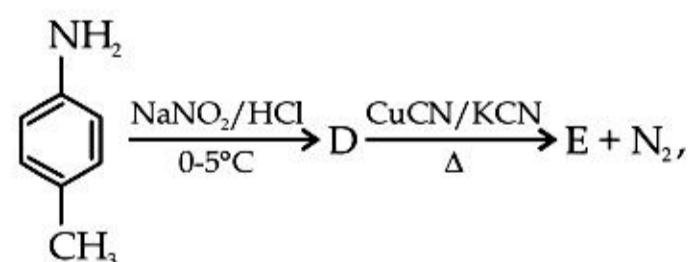

the product E is

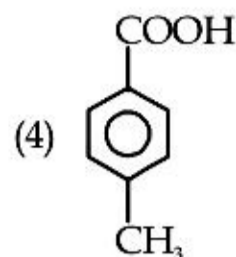
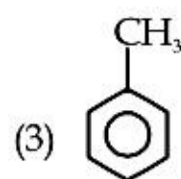
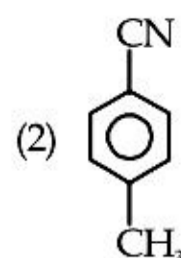
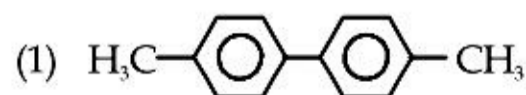

Answer (2)

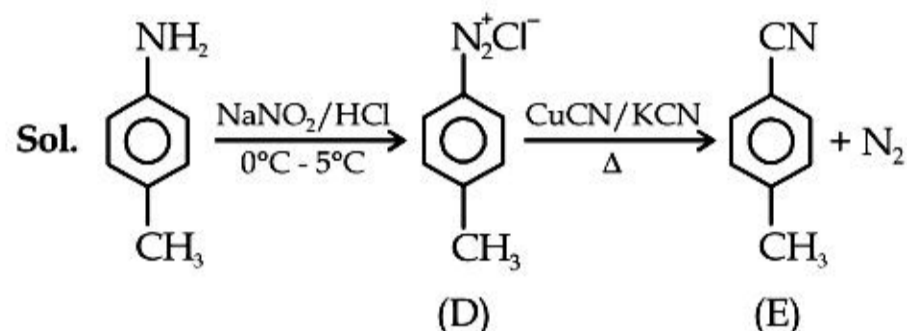

11. Which polymer is used in the manufacture of paints and lacquers?

- (1) Glyptal
- (2) Polypropene
- (3) Poly vinyl chloride
- (4) Bakelite

Answer (1)

Sol. Glyptal is used in manufacture of paints and lacquers.

12. The number of geometric isomers that can exist for square planar $[Pt(Cl)(py)(NH_3)(NH_2OH)]^+$ is (py = pyridine)

- (1) 3
- (2) 4
- (3) 6
- (4) 2

Answer (1)

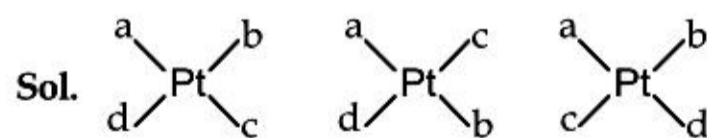

as per question a = Cl, b = py, c = NH_3 and d = NH_2OH are assumed.

13. Higher order (>3) reactions are rare due to

- (1) Increase in entropy and activation energy as more molecules are involved
- (2) Shifting of equilibrium towards reactants due to elastic collisions
- (3) Loss of active species on collision
- (4) Low probability of simultaneous collision of all the reacting species

Answer (4)

Sol. Higher order greater than 3 for reaction is rare because there is low probability of simultaneous collision of all the reacting species.

14. Which among the following is the most reactive?

- (1) Br₂ (2) I₂
(3) ICl (4) Cl₂

Answer (3)

Sol. Because of polarity and weak bond interhalogen compounds are more reactive.

15. Two faraday of electricity is passed through a solution of CuSO₄. The mass of copper deposited at the cathode is (at. mass of Cu = 63.5 amu)

- (1) 63.5 g (2) 2 g
(3) 127 g (4) 0 g

Answer (1)

Sol. Cu⁺² + 2e → Cu

So, 2 F charge deposit 1 mol of Cu. Mass deposited = 63.5 g.

16. 3 g of activated charcoal was added to 50 mL of acetic acid solution (0.06N) in a flask. After an hour it was filtered and the strength of the filtrate was found to be 0.042 N. The amount of acetic acid adsorbed (per gram of charcoal) is

- (1) 36 mg (2) 42 mg
(3) 54 mg (4) 18 mg

Answer (4)

Sol. Number of moles of acetic acid adsorbed

$$= \left(0.06 \times \frac{50}{1000} - 0.042 \times \frac{50}{1000} \right)$$

$$= \frac{0.9}{1000} \text{ moles}$$

$$\therefore \text{Weight of acetic acid adsorbed} = 0.9 \times 60 \text{ mg} \\ = 54 \text{ mg}$$

Hence, the amount of acetic acid adsorbed per g of

$$\text{charcoal} = \frac{54}{3} \text{ mg} \\ = 18 \text{ mg}$$

Hence, option (4) is correct.

17. The synthesis of alkyl fluorides is best accomplished by

- (1) Sandmeyer's reaction
(2) Finkelstein reaction
(3) Swarts reaction
(4) Free radical fluorination

Answer (3)

Sol. Swart's reaction

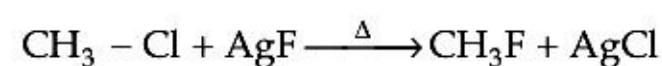

18. The molecular formula of a commercial resin used for exchanging ions in water softening is C₈H₇SO₃Na (mol. wt. 206). What would be the maximum uptake of Ca²⁺ ions by the resin when expressed in mole per gram resin?

- (1) $\frac{1}{206}$ (2) $\frac{2}{309}$
(3) $\frac{1}{412}$ (4) $\frac{1}{103}$

Answer (3)

Sol. Ca⁺² + 2C₈H₇SO₃⁻Na⁺ → Ca(C₈H₇SO₃⁻)₂ + 2Na⁺
1 mol 2 mol

$$\text{The maximum uptake} = \frac{1}{206 \times 2} = \frac{1}{412} \text{ mol/g}$$

19. Which of the vitamins given below is water soluble?

- (1) Vitamin D (2) Vitamin E
(3) Vitamin K (4) Vitamin C

Answer (4)

Sol. Vitamin C is water soluble vitamin.

20. The intermolecular interaction that is dependent on the inverse cube of distance between the molecules is

- (1) Ion-dipole interaction
(2) London force
(3) Hydrogen bond
(4) Ion-ion interaction

Answer (3)

Sol. H-bond is one of the dipole-dipole interaction and dependent on inverse cube of distance between the molecules.

21. The following reaction is performed at 298 K.

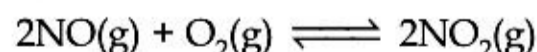

The standard free energy of formation of NO(g) is 86.6 kJ/mol at 298 K. What is the standard free energy of formation of NO₂(g) at 298 K?

$$(K_p = 1.6 \times 10^{12})$$

(1) 86600 + R(298) ln(1.6 × 10¹²)

(2) 86600 - $\frac{\ln(1.6 \times 10^{12})}{R(298)}$

(3) 0.5 [2 × 86,600 - R(298) ln 1.6 × 10¹²]

(4) R(298) ln(1.6 × 10¹²) - 86600

Answer (3)

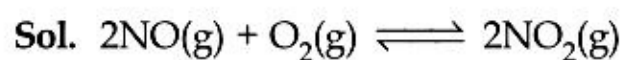

$$(\Delta G^\circ)_{\text{reaction}} = \left[(\Delta G^\circ)_{\text{formation}} \right]_{\text{product}} - \left[(\Delta G^\circ)_{\text{formation}} \right]_{\text{reactant}}$$

$$\Rightarrow -RT \ln K_P = 2 \times (\Delta G^\circ)_{\text{NO}_2} - 2(\Delta G^\circ)_{\text{NO}}$$

$$\Rightarrow (\Delta G^\circ)_{\text{NO}_2} = 2(\Delta G^\circ)_{\text{NO}} - RT \ln K_P$$

$$\Rightarrow (\Delta G^\circ)_{\text{NO}_2} = \frac{2 \times 86600 - R(298) \ln K_P}{2}$$

$$= \frac{2 \times 86600 - R(298) \ln 1.6 \times 10^{12}}{2}$$

$$= 0.5 [2 \times 86,600 - R(298) \ln 1.6 \times 10^{12}]$$

22. Which of the following compounds is **not** colored yellow?

- (1) $\text{K}_3[\text{Co}(\text{NO}_2)_6]$
- (2) $(\text{NH}_4)_3[\text{As}(\text{Mo}_3\text{O}_{10})_4]$
- (3) BaCrO_4
- (4) $\text{Zn}_2[\text{Fe}(\text{CN})_6]$

Answer (4)

Sol. $(\text{NH}_4)_3[\text{As}(\text{Mo}_3\text{O}_{10})_4]$, BaCrO_4 and $\text{K}_3[\text{Co}(\text{NO}_2)_6]$ are yellow colored compounds but $\text{Zn}_2[\text{Fe}(\text{CN})_6]$ is not yellow colored compound.

23. In Carius method of estimation of halogens, 250 mg of an organic compound gave 141 mg of AgBr. The percentage of bromine in the compound is (at mass Ag = 108; Br = 80)

- (1) 36
- (2) 48
- (3) 60
- (4) 24

Answer (4)

Sol. Percentage of Br

$$= \frac{\text{Weight of AgBr}}{\text{Mol. mass of AgBr}} \times \frac{\text{Mol. mass of Br}}{\text{Weight of O.C.}} \times 100$$

$$= \frac{141}{188} \times \frac{80}{250} \times 100$$

$$= 24\%$$

24. Sodium metal crystallizes in a body centred cubic lattice with a unit cell edge of 4.29 Å. The radius of sodium atom is approximately

- (1) 3.22 Å
- (2) 5.72 Å
- (3) 0.93 Å
- (4) 1.86 Å

Answer (4)

Sol. Edge length of BCC is 4.29 Å.

In BCC,

$$\text{edge length} = \frac{4}{\sqrt{3}} r$$

$$4.29 = \frac{4}{\sqrt{3}} r$$

$$r = \frac{4.29}{4} \sqrt{3} \approx 1.86 \text{ \AA}$$

25. Which of the following compounds will exhibit geometrical isomerism?

- (1) 3 - Phenyl - 1 - butene
- (2) 2 - Phenyl - 1 - butene
- (3) 1, 1 - Diphenyl - 1 propane
- (4) 1 - Phenyl - 2 - butene

Answer (4)

Sol. For geometrical isomerism doubly bonded carbon must be bonded to two different groups which is only satisfied by 1 - Phenyl - 2 - butene.

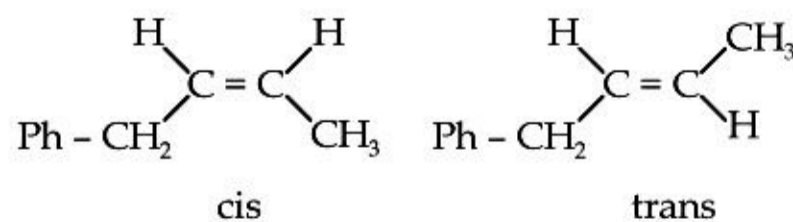

26. The vapour pressure of acetone at 20°C is 185 torr. When 1.2 g of a non-volatile substance was dissolved in 100 g of acetone at 20°C, its vapour pressure was 183 torr. The molar mass (g mol^{-1}) of the substance is

- (1) 64
- (2) 128
- (3) 488
- (4) 32

Answer (1)

Sol. Vapour pressure of pure acetone $P_A^\circ = 185$ torr
 Vapour pressure of solution, $P_S = 183$ torr
 Molar mass of solvent, $M_A = 58$ g/mole

$$\text{as we know } \frac{P_A^\circ - P_S}{P_S} = \frac{n_B}{n_A}$$

$$\Rightarrow \frac{185 - 183}{183} = \frac{W_B}{M_B} \times \frac{M_A}{W_A}$$

$$\Rightarrow \frac{2}{183} = \frac{1.2}{M_B} \times \frac{58}{100}$$

$$\Rightarrow M_B = \frac{1.2}{2} \times \frac{58}{100} \times 183$$

$$= 63.68 \text{ g/mole}$$

27. From the following statement regarding H_2O_2 , choose the **incorrect** statement

- (1) It decomposes on exposure to light
- (2) It has to be stored in plastic or wax lined glass bottles in dark.
- (3) It has to be kept away from dust
- (4) It can act only as an oxidizing agent

Answer (4)

Sol. H_2O_2 can be reduced or oxidised. Hence, it can act as reducing as well as oxidising agent.

28. Which one of the following alkaline earth metal sulphates has its hydration enthalpy greater than its lattice enthalpy?

- | | |
|--------------|--------------|
| (1) $BeSO_4$ | (2) $BaSO_4$ |
| (3) $SrSO_4$ | (4) $CaSO_4$ |

Answer (1)

Sol. $BeSO_4$ has hydration energy greater than its lattice energy.

29. The standard Gibbs energy change at 300 K for the reaction $2A \rightleftharpoons B + C$ is 2494.2 J. At a given time, the composition of the reaction mixture is

$$[A] = \frac{1}{2}, [B] = 2 \text{ and } [C] = \frac{1}{2}. \text{ The reaction proceeds}$$

in the : $[R = 8.314 \text{ J/K/mol, } e = 2.718]$

- (1) Reverse direction because $Q > K_C$
- (2) Forward direction because $Q < K_C$
- (3) Reverse direction because $Q < K_C$
- (4) Forward direction because $Q > K_C$

Answer (1)

Sol. $2A \rightleftharpoons B + C, \Delta G^\circ = 2494.2 \text{ J}$

As we know $\Delta G^\circ = -2.303 RT \log K_C$

$$\Rightarrow 2494.2 = -2.303 \times 8.314 \times 300 \log K_C$$

$$\Rightarrow -0.434 = \log K_C$$

$$\Rightarrow K_C = \text{anti log } (-0.434)$$

$$\Rightarrow K_C = 0.367$$

$$\text{Now } [A] = \frac{1}{2}, [B] = 2 \text{ and } [C] = \frac{1}{2}$$

$$\text{Now } Q_C = \frac{[C][B]}{[A]^2} = \frac{\left(\frac{1}{2}\right)(2)}{\left(\frac{1}{2}\right)^2} = 4$$

as $Q_C > K_C$, hence reaction will shift in backward direction.

30. Which one has the highest boiling point?

- | | |
|--------|--------|
| (1) Ne | (2) Kr |
| (3) Xe | (4) He |

Answer (3)

Sol. Down the group strength of van der Waal's force of attraction increases hence Xe have highest boiling point.

PART-B : MATHEMATICS

31. The sum of coefficients of integral powers of x in the binomial expansion of $(1 - 2\sqrt{x})^{50}$ is

(1) $\frac{1}{2}(3^{50})$	(2) $\frac{1}{2}(3^{50} - 1)$
---------------------------	-------------------------------

(3) $\frac{1}{2}(2^{50} + 1)$	(4) $\frac{1}{2}(3^{50} + 1)$
-------------------------------	-------------------------------

Answer (4)

$$\text{Sol. } (1 - 2\sqrt{x})^{50} = {}^{50}C_0 - {}^{50}C_1(2\sqrt{x})^1 + {}^{50}C_2(2\sqrt{x})^2 + \dots + {}^{50}C_{50}(-2\sqrt{x})^{50}$$

Sum of coefficient of integral power of x

$$= {}^{50}C_0 \cdot 2^0 + {}^{50}C_2 \cdot 2^2 + {}^{50}C_4 \cdot 2^4 + \dots + {}^{50}C_{50} \cdot 2^{50}$$

We know that

$$(1 + 2)^{50} = {}^{50}C_0 + {}^{50}C_1 \cdot 2 + \dots + {}^{50}C_{50} \cdot 2^{50}$$

Then,

$${}^{50}C_0 + {}^{50}C_2 \cdot 2^2 + \dots + {}^{50}C_{50} \cdot 2^{50} = \frac{3^{50} + 1}{2}$$

32. Let $f(x)$ be a polynomial of degree four having extreme values at $x = 1$ and $x = 2$. If $\lim_{x \rightarrow 0} \left[1 + \frac{f(x)}{x^2} \right] = 3$, then $f(2)$ is equal to
- (1) -4 (2) 0
(3) 4 (4) -8

Answer (2)

Sol. Let $f(x) = a_0 + a_1x + a_2x^2 + a_3x^3 + a_4x^4$

$$\text{Using } \lim_{x \rightarrow 0} \left[1 + \frac{f(x)}{x^2} \right] = 3$$

$$\Rightarrow \lim_{x \rightarrow 0} \frac{f(x)}{x^2} = 2$$

$$\Rightarrow \lim_{x \rightarrow 0} \frac{a_0 + a_1x + a_2x^2 + a_3x^3 + a_4x^4}{x^2} = 2$$

$$\text{So, } a_0 = 0, a_1 = 0, a_2 = 2$$

$$\text{i.e., } f(x) = 2x^2 + a_3x^3 + a_4x^4$$

$$\text{Now, } f'(x) = 4x + 3a_3x^2 + 4a_4x^3$$

$$= x[4 + 3a_3x + 4a_4x^2]$$

$$\text{Given, } f'(1) = 0 \text{ and } f'(2) = 0$$

$$\Rightarrow 3a_3 + 4a_4 + 4 = 0 \quad \dots(i)$$

$$\text{and } 6a_3 + 16a_4 + 4 = 0 \quad \dots(ii)$$

$$\text{Solving, } a_4 = \frac{1}{2}, a_3 = -2$$

$$\text{i.e., } f(x) = 2x^2 - 2x^3 + \frac{1}{2}x^4$$

$$\text{i.e., } f(2) = 0$$

33. The mean of the data set comprising of 16 observations is 16. If one of the observation valued 16 is deleted and three new observations valued 3, 4 and 5 are added to the data, then the mean of the resultant data, is
- (1) 16.0 (2) 15.8
(3) 14.0 (4) 16.8

Answer (3)

Sol. Mean = 16

$$\text{Sum} = 16 \times 16 = 256$$

$$\text{New sum} = 256 - 16 + 3 + 4 + 5 = 252$$

$$\text{Mean} = \frac{252}{18} = 14$$

34. The sum of first 9 terms of the series

$$\frac{1^3}{1} + \frac{1^3 + 2^3}{1+3} + \frac{1^3 + 2^3 + 3^3}{1+3+5} + \dots \text{ is}$$

- (1) 96 (2) 142
(3) 192 (4) 71

Answer (1)

Sol. $t_n = \frac{\left[\frac{n(n+1)}{2} \right]^2}{n^2}$

$$= \frac{(n+1)^2}{4}$$

$$= \frac{1}{4} [n^2 + 2n + 1]$$

$$= \frac{1}{4} \left[\frac{n(n+1)(2n+1)}{6} + \frac{2(n)(n+1)}{2} + 1 \right]$$

$$= \frac{1}{4} \left[\frac{9 \times 10 \times 19}{6} + 9 \times 10 + 9 \right]$$

$$= 96$$

35. Let O be the vertex and Q be any point on the parabola, $x^2 = 8y$. If the point P divides the line segment OQ internally in the ratio 1 : 3, then the locus of P is

- (1) $y^2 = x$ (2) $y^2 = 2x$
(3) $x^2 = 2y$ (4) $x^2 = y$

Answer (3)

Sol. $x^2 = 8y$

Let Q be $(4t, 2t^2)$

$$\therefore P = \left(t, \frac{t^2}{2} \right)$$

Let P be (h, k)

$$\therefore h = t, k = \frac{t^2}{2}$$

$$\therefore 2k = h^2$$

$$\therefore \text{Locus of } (h, k) \text{ is } x^2 = 2y.$$

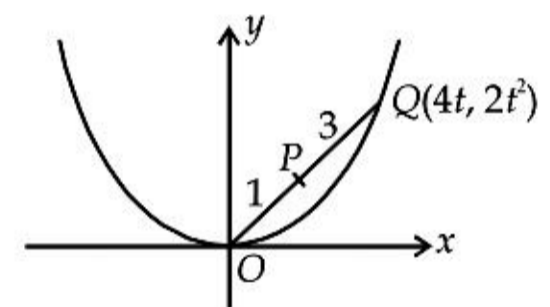

36. Let α and β be the roots of equation $x^2 - 6x - 2 = 0$.

If $a_n = \alpha^n - \beta^n$, for $n \geq 1$, then the value of $\frac{a_{10} - 2a_8}{2a_9}$

is equal to

- (1) -6 (2) 3
(3) -3 (4) 6

Answer (2)

Sol. From equation,

$$\alpha + \beta = 6$$

$$\alpha\beta = -2$$

$$\text{The value of } \frac{a_{10} - 2a_8}{2a_9} = \frac{\alpha^{10} + \beta^{10} + \alpha\beta(\alpha^8 + \beta^8)}{2(\alpha^9 + \beta^9)}$$

$$= \frac{\alpha^9(\alpha + \beta) + \beta^9(\alpha + \beta)}{2(\alpha^9 + \beta^9)}$$

$$= \frac{\alpha + \beta}{2} = \frac{6}{2} = 3$$

37. If 12 identical balls are to be placed in 3 identical boxes, then the probability that one the boxes contains exactly 3 balls is

- (1) $55\left(\frac{2}{3}\right)^{10}$ (2) $220\left(\frac{1}{3}\right)^{12}$
 (3) $22\left(\frac{1}{3}\right)^{11}$ (4) $\frac{55}{3}\left(\frac{2}{3}\right)^{11}$

Answer (4)*

Sol. Question is wrong but the best suitable option is (4).

$$\text{Required probability} = {}^{12}C_3 \frac{2^9}{3^{12}} = \frac{55}{3}\left(\frac{2}{3}\right)^{11}$$

38. A complex number z is said to be unimodular if $|z| = 1$. Suppose z_1 and z_2 are complex numbers

such that $\frac{z_1 - 2z_2}{2 - z_1\bar{z}_2}$ is unimodular and z_2 is not

unimodular. Then the point z_1 lies on a

- (1) Straight line parallel to y -axis
 (2) Circle of radius 2
 (3) Circle of radius $\sqrt{2}$
 (4) Straight line parallel to x -axis

Answer (2)

Sol. $\left(\frac{z_1 - 2z_2}{2 - z_1\bar{z}_2}\right) = 1$

$$\left(\frac{z_1 - 2z_2}{2 - z_1\bar{z}_2}\right)\left(\frac{\bar{z}_1 - 2\bar{z}_2}{2 - \bar{z}_1z_2}\right) = 1$$

$$z_1\bar{z}_1 - 2z_1\bar{z}_2 - 2z_2\bar{z}_1 + 4z_2\bar{z}_2 = 4 - 2\bar{z}_1z_2 - 2z_1\bar{z}_2 + z_1\bar{z}_1z_2\bar{z}_2$$

$$z_1\bar{z}_1 + 4z_2\bar{z}_2 = 4 + z_1\bar{z}_1z_2\bar{z}_2$$

$$z\bar{z}_1(1 - z_2\bar{z}_2) - 4(1 - z_2\bar{z}_2) = 0$$

$$(z_1\bar{z}_1 - 4)(1 - z_2\bar{z}_2) = 0$$

$$\Rightarrow z_1\bar{z}_1 = 4$$

$$|z| = 2$$

i.e. z lies on circle of radius 2.

39. The integral $\int \frac{dx}{x^2(x^4 + 1)^{3/4}}$ equals

- (1) $(x^4 + 1)^{\frac{1}{4}} + c$ (2) $-(x^4 + 1)^{\frac{1}{4}} + c$
 (3) $-\left(\frac{x^4 + 1}{x^4}\right)^{\frac{1}{4}} + c$ (4) $\left(\frac{x^4 + 1}{x^4}\right)^{\frac{1}{4}} + c$

Answer (3)

Sol. $I = \int \frac{dx}{x^2(x^4 + 1)^{3/4}} = \int \frac{dx}{x^5\left(1 + \frac{1}{x^4}\right)^{3/4}}$

$$\text{Let } 1 + \frac{1}{x^4} = t \Rightarrow \frac{-4}{x^5} dx = dt$$

$$\text{So, } I = \frac{-1}{4} \int \frac{dt}{t^{3/4}} = \frac{-1}{4} \int t^{-3/4} dt$$

$$= \frac{-1}{4} \left(\frac{t^{1/4}}{1/4}\right) + c$$

$$= -\left(1 + \frac{1}{x^4}\right)^{1/4} + c$$

So, option (3).

40. The number of points, having both co-ordinates as integers, that lie in the interior of the triangle with vertices $(0, 0)$, $(0, 41)$ and $(41, 0)$, is

- (1) 861 (2) 820
 (3) 780 (4) 901

Answer (3)

Sol.

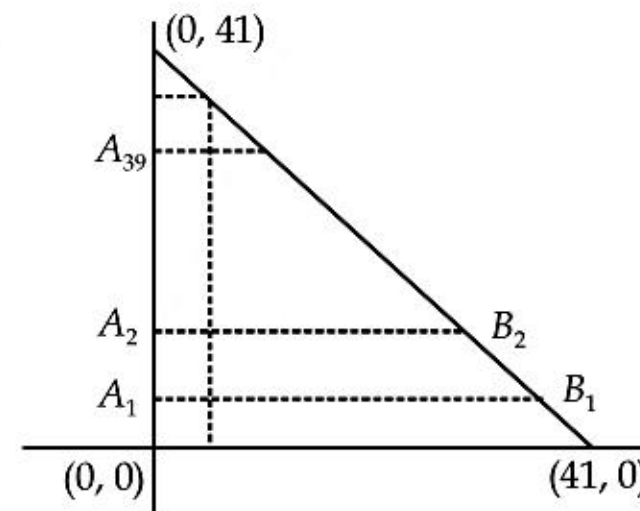

Total number of integral coordinates as required

$$= 39 + 38 + 37 + \dots + 1 = \frac{39 \times 40}{2} = 780$$

41. The distance of the point $(1, 0, 2)$ from the point of intersection of the line $\frac{x-2}{3} = \frac{y+1}{4} = \frac{z-2}{12}$ and the plane $x - y + z = 16$, is

- (1) 8 (2) $3\sqrt{21}$
 (3) 13 (4) $2\sqrt{14}$

Answer (3)

Sol. $\frac{x-2}{3} = \frac{y+1}{4} = \frac{z-2}{12} = \lambda$

$$P(3\lambda + 2, 4\lambda - 1, 12\lambda + 2)$$

Lies on plane $x - y + z = 16$

Then,

$$3\lambda + 2 - 4\lambda + 1 + 12\lambda + 2 = 16$$

$$11\lambda + 5 = 16$$

$$\lambda = 1 \quad P(5, 3, 14)$$

$$\text{Distance} = \sqrt{16 + 9 + 144} = \sqrt{169} = 13$$

42. The equation of the plane containing the line $2x - 5y + z = 3$; $x + y + 4z = 5$, and parallel to the plane, $x + 3y + 6z = 1$, is

- (1) $x + 3y + 6z = -7$ (2) $x + 3y + 6z = 7$
 (3) $2x + 6y + 12z = -13$ (4) $2x + 6y + 12z = 13$

Answer (2)

Sol. Required plane is

$$(2x - 5y + z - 3) + \lambda(x + y + 4z - 5) = 0$$

$$\text{It is parallel to } x + 3y + 6z = 1$$

$$\therefore \frac{2+\lambda}{1} = \frac{-5+\lambda}{3} = \frac{1+4\lambda}{6}$$

$$\text{Solving } \lambda = \frac{-11}{2}$$

\therefore Required plane is

$$(2x - 5y + z - 3) - \frac{11}{2}(x + y + 4z - 5) = 0$$

$$\therefore x + 3y + 6z - 7 = 0$$

43. The area (in sq. units) of the region described by $\{(x, y) : y^2 \leq 2x \text{ and } y \geq 4x - 1\}$ is

- (1) $\frac{5}{64}$ (2) $\frac{15}{64}$
 (3) $\frac{9}{32}$ (4) $\frac{7}{32}$

Answer (3)

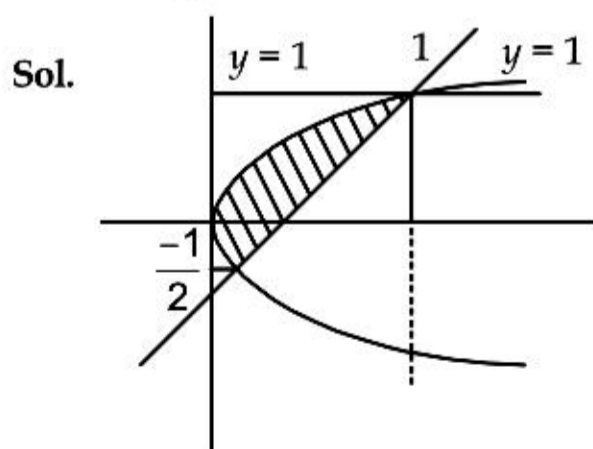

After solving $y = 4x - 1$ and $y^2 = 2x$

$$y = 4 \cdot \frac{y^2}{2} - 1$$

$$2y^2 - y - 1 = 0$$

$$y = \frac{1 \pm \sqrt{1+8}}{4} = \frac{1 \pm 3}{4} \quad y = 1, \frac{-1}{2}$$

$$A = \int_{-1/2}^1 \left(\frac{y+1}{4} \right) dy - \int_{-1/2}^1 \frac{y^2}{2} dy$$

$$= \frac{1}{4} \left[\frac{y^2}{2} + y \right]_{-1/2}^1 - \frac{1}{2} \left[\frac{y^3}{3} \right]_{-1/2}^1$$

$$= \frac{1}{4} \left[\frac{4+8-1+4}{8} \right] - \frac{1}{2} \left[\frac{8+1}{24} \right]$$

$$= \frac{1}{4} \left[\frac{15}{8} \right] - \frac{9}{48}$$

$$= \frac{15}{32} - \frac{6}{32} = \frac{9}{32}$$

44. If m is the A.M. of two distinct real numbers l and n ($l, n > 1$) and G_1, G_2 and G_3 are three geometric means between l and n , then $G_1^4 + 2G_2^4 + G_3^4$ equals.

- (1) $4lm^2n$
 (2) $4lmn^2$
 (3) $4l^2m^2n^2$
 (4) $4l^2mn$

Answer (1)

Sol. $\frac{l+n}{2} = m$

$$l + n = 2m \quad \dots(i)$$

$$G_1 = l \left(\frac{n}{l} \right)^{\frac{1}{4}}$$

$$G_2 = l \left(\frac{n}{l} \right)^{\frac{2}{4}}$$

$$G_3 = l \left(\frac{n}{l} \right)^{\frac{3}{4}}$$

$$\text{Now } G_1^4 + 2G_2^4 + G_3^4$$

$$l^4 \cdot \frac{n}{l} + 2 \cdot (l^2) \left(\frac{n}{l} \right)^2 + l^4 \left(\frac{n}{l} \right)^3$$

$$= nl^3 + 2n^2l^2 + n^3l$$

$$= 2n^2l^2 + nl(n^2 + l^2)$$

$$= 2n^2l^2 + nl((n+l)^2 - 2nl)$$

$$= nl(n+l)^2$$

$$= nl \cdot (2m)^2$$

$$= 4nlm^2$$

45. Locus of the image of the point (2, 3) in the line $(2x - 3y + 4) + k(x - 2y + 3) = 0, k \in R$, is a
- (1) Straight line parallel to y -axis
 - (2) Circle of radius $\sqrt{2}$
 - (3) Circle of radius $\sqrt{3}$
 - (4) Straight line parallel to x -axis

Answer (2)

Sol. After solving equation (i) & (ii)

$$2x - 3y + 4 = 0 \quad \dots(i)$$

$$2x - 4y + 6 = 0 \quad \dots(ii)$$

$$x = 1 \text{ and } y = 2$$

$$\text{Slope of } AB \times \text{Slope of } MN = -1$$

$$\frac{b-3}{a-2} \times \frac{\frac{b+3}{2} - 2}{\frac{a+2}{2} - 1} = -1$$

$$(y-3)(y-1) = -(x-2)x$$

$$y^2 - 4y + 3 = -x^2 + 2x$$

$$x^2 + y^2 - 2x - 4y + 3 = 0$$

$$\text{Circle of radius} = \sqrt{2}$$

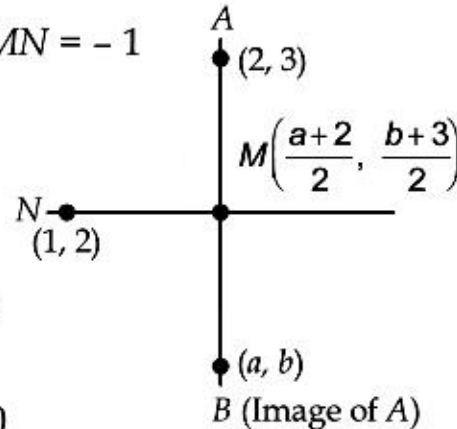

46. The area (in sq. units) of the quadrilateral formed by the tangents at the end points of the latera recta to

the ellipse $\frac{x^2}{9} + \frac{y^2}{5} = 1$, is

- (1) 18
- (2) $\frac{27}{2}$
- (3) 27
- (4) $\frac{27}{4}$

Answer (3)

Sol. Ellipse is $\frac{x^2}{9} + \frac{y^2}{5} = 1$

$$\text{i.e., } a^2 = 9, b^2 = 5$$

$$\text{So, } e = \frac{2}{3}$$

$$\text{As, required area} = \frac{2a^2}{e} = \frac{2 \times 9}{(2/3)} = 27$$

47. The number of integers greater than 6,000 that can be formed, using the digits 3, 5, 6, 7 and 8, without repetition, is

- (1) 192
- (2) 120
- (3) 72
- (4) 216

Answer (1)

Sol. 4 digit numbers

3, 5, 6, 7, 8

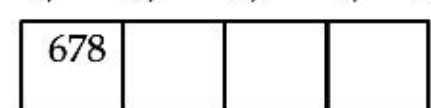

$$3 + 4 + 5 + 2 = 72$$

5 digit numbers

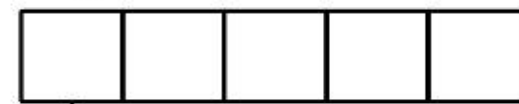

5

$$5 \times 4 \times 3 \times 2 \times 1 = 120$$

$$\text{Total number of integers} = 72 + 120 = 192$$

48. Let A and B be two sets containing four and two elements respectively. Then the number of subsets of the set $A \times B$, each having at least three elements is

- (1) 256
- (2) 275
- (3) 510
- (4) 219

Answer (4)

Sol. $n(A) = 4, n(B) = 2$

$$n(A \times B) = 8$$

$$\text{Required numbers} = {}^8C_3 + {}^8C_4 + \dots + {}^8C_8$$

$$= 2^8 - ({}^8C_0 + {}^8C_1 + {}^8C_2)$$

$$= 256 - 37$$

$$= 219$$

49. Let $\tan^{-1} y = \tan^{-1} x + \tan^{-1} \left(\frac{2x}{1-x^2} \right)$

where $|x| < \frac{1}{\sqrt{3}}$. Then a value of y is

- (1) $\frac{3x+x^3}{1-3x^2}$
- (2) $\frac{3x-x^3}{1+3x^2}$
- (3) $\frac{3x+x^3}{1+3x^2}$
- (4) $\frac{3x-x^3}{1-3x^2}$

Answer (4)

Sol. $\tan^{-1} y = \tan^{-1} x + \tan^{-1} \left(\frac{2x}{1-x^2} \right)$

$$3 \tan^{-1} x = \tan^{-1} \left(\frac{3x-x^3}{1-3x^2} \right)$$

$$y = \frac{3x-x^3}{1-3x^2}$$

50. The integral $\int_2^4 \frac{\log x^2}{\log x^2 + \log(36-12x+x^2)} dx$ is equal to

- (1) 4
- (2) 1
- (3) 6
- (4) 2

Answer (2)

Sol. $I = \int_2^4 \frac{\log x^2}{\log x^2 + \log(36-12x+x^2)} dx$

$$I = \int_2^4 \frac{\log(6-x)^2 dx}{2 \log x^2 + \log(6-x)^2}$$

$$2I = \int_2^4 1 dx$$

$$2I = 2$$

$$I = 1$$

51. The negation of $\sim s \vee (\sim r \wedge s)$ is equivalent to

- (1) $s \wedge (r \wedge \sim s)$ (2) $s \vee (r \vee \sim s)$
 (3) $s \wedge r$ (4) $s \wedge \sim r$

Answer (3)

Sol. $\sim(\sim s \vee (\sim r \wedge s))$

$$= s \wedge (r \vee \sim s)$$

$$= (s \wedge r) \vee (s \wedge \sim s)$$

$$= s \wedge r$$

52. If the angles of elevation of the top of a tower from three collinear points A, B and C, on a line leading to the foot of the tower, are 30° , 45° and 60° respectively, then the ratio, AB : BC, is

- (1) $\sqrt{3} : \sqrt{2}$ (2) $1 : \sqrt{3}$
 (3) $2 : 3$ (4) $\sqrt{3} : 1$

Answer (4)

Sol. $AO = h \cot 30^\circ$

$$= h\sqrt{3}$$

$$BO = h$$

$$CO = \frac{h}{\sqrt{3}}$$

$$\therefore \frac{AB}{BC} = \frac{AO - BO}{BO - CO}$$

$$= \frac{h\sqrt{3} - h}{h - \frac{h}{\sqrt{3}}}$$

$$= \sqrt{3}$$

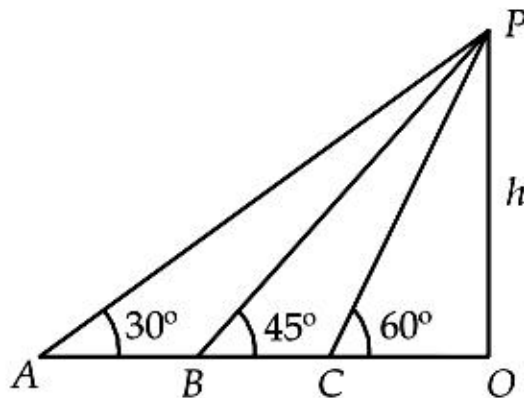

53. $\lim_{x \rightarrow 0} \frac{(1 - \cos 2x)(3 + \cos x)}{x \tan 4x}$ is equal to

- (1) 3 (2) 2
 (3) $\frac{1}{2}$ (4) 4

Answer (2)

Sol. $\lim_{x \rightarrow 0} \frac{2 \sin^2 x \cdot (3 + \cos x)}{x^2 \frac{\tan 4x}{4x} \times 4x} \times \frac{x^2}{x} = 2$

54. Let \vec{a} , \vec{b} and \vec{c} be three non-zero vectors such that no two of them are collinear and $(\vec{a} \times \vec{b}) \times \vec{c} = \frac{1}{3} |\vec{b}| |\vec{c}| \vec{a}$. If θ is the angle between vectors \vec{b} and \vec{c} , then a value of $\sin \theta$ is

- (1) $\frac{-\sqrt{2}}{3}$ (2) $\frac{2}{3}$
 (3) $\frac{-2\sqrt{3}}{3}$ (4) $\frac{2\sqrt{2}}{3}$

Answer (4)

Sol. $(\vec{a} \cdot \vec{c}) \vec{b} - (\vec{b} \cdot \vec{c}) \vec{a} = \frac{1}{3} |\vec{b}| |\vec{c}| \vec{a}$

$$\therefore -(\vec{b} \cdot \vec{c}) = \frac{1}{3} |\vec{b}| |\vec{c}|$$

$$\therefore \cos \theta = -\frac{1}{3}$$

$$\therefore \sin \theta = \frac{2\sqrt{2}}{3}$$

55. If $A = \begin{bmatrix} 1 & 2 & 2 \\ 2 & 1 & -2 \\ a & 2 & b \end{bmatrix}$ is a matrix satisfying the

equation $AA^T = 9I$, where I is 3×3 identity matrix, then the ordered pair (a, b) is equal to

- (1) $(-2, 1)$ (2) $(2, 1)$
 (3) $(-2, -1)$ (4) $(2, -1)$

Answer (3)

Sol. $\begin{bmatrix} 1 & 2 & 2 \\ 2 & 1 & -2 \\ a & 2 & b \end{bmatrix} \begin{bmatrix} 1 & 2 & a \\ 2 & 1 & 2 \\ 2 & -2 & b \end{bmatrix} = \begin{bmatrix} 9 & 0 & 0 \\ 0 & 9 & 0 \\ 0 & 0 & 9 \end{bmatrix}$

$$a + 4 + 2b = 0$$

$$2a + 2 - 2b = 0$$

$$a + 1 - b = 0$$

$$2a - 2b = -2$$

$$a + 2b = -4$$

$$3a = -6$$

$$a = -2$$

$$-2 + 1 - b = 0$$

$$b = -1$$

$$a = -2$$

$$(-2, -1)$$

$$\Rightarrow y = 2 - x$$

Solving it with the curve, we get

$$x^2 + 2x(2 - x) - 3(2 - x)^2 = 0$$

$$\Rightarrow -4x^2 + 16x - 12 = 0$$

$$\Rightarrow x^2 - 4x + 3 = 0$$

$$\Rightarrow x = 1, 3$$

So points of intersections are (1, 1) & (3, -1) i.e. normal cuts the curve again in fourth quadrant.

59. The number of common tangents to the circles

$$x^2 + y^2 - 4x - 6y - 12 = 0 \text{ and}$$

$$x^2 + y^2 + 6x + 18y + 26 = 0, \text{ is}$$

(1) 2 (2) 3

(3) 4 (4) 1

Answer (2)

Sol. $x^2 + y^2 - 4x - 6y - 12 = 0$

$$C_1(\text{center}) = (2, 3), r = \sqrt{2^2 + 3^2 + 12} = 5$$

$$x^2 + y^2 + 6x + 18y + 26 = 0$$

$$C_2(\text{center}) = (-3, -9), r = \sqrt{9 + 81 - 26}$$

$$= \sqrt{64} = 8$$

$$C_1 C_2 = 13, C_1 C_2 = r_1 + r_2$$

Number of common tangent is 3.

60. Let $y(x)$ be the solution of the differential equation

$$(x \log x) \frac{dy}{dx} + y = 2x \log x, (x \geq 1).$$

Then $y(e)$ is equal to

(1) 0 (2) 2

(3) $2e$ (4) e

Answer (2)*

Sol. It is best option. Theoretically question is wrong, because initial condition is not given.

$$x \log x \frac{dy}{dx} + y = 2x \log x \quad \text{If } x = 1 \text{ then } y = 0$$

$$\frac{dy}{dx} + \frac{y}{x \log x} = 2$$

$$\text{I.F.} = e^{\int \frac{1}{x \log x} dx} = e^{\log \log x} = \log x$$

$$\text{Solution is } y \cdot \log x = \int 2 \log x dx + c$$

$$y \log x = 2(x \log x - x) + c$$

$$x = 1, y = 0$$

$$\text{Then, } c = 2, y(e) = 2$$

PART-C : PHYSICS

61. As an electron makes a transition from an excited state to the ground state of a hydrogen-like atom/ion

(1) Kinetic energy, potential energy and total energy decrease

(2) Kinetic energy decreases, potential energy increases but total energy remains same

(3) Kinetic energy and total energy decrease but potential energy increases

(4) Its kinetic energy increases but potential energy and total energy decrease

Answer (4)

$$\text{Sol. PE} = -27.2 \frac{z^2}{n^2} \text{ eV}$$

$$\text{TE} = -\frac{13.6z^2}{n^2} \text{ eV}$$

$$\text{KE} = \frac{13.6z^2}{n^2} \text{ eV}$$

$$\text{KE} = \frac{13.6}{n^2} \text{ eV}, \text{ As } n \text{ decreases, KE} \uparrow$$

$$\text{PE} = -\frac{27.2}{n^2} \text{ eV}, \text{ as } n \text{ decreases, PE} \downarrow$$

$$\text{TE} = -\frac{13.6}{n^2} \text{ eV}, \text{ as } n \text{ decreases, TE} \downarrow$$

62. The period of oscillation of a simple pendulum is

$$T = 2\pi \sqrt{\frac{L}{g}}. \text{ Measured value of } L \text{ is } 20.0 \text{ cm known}$$

to 1 mm accuracy and time for 100 oscillations of the pendulum is found to be 90 s using a wrist watch of 1 s resolution. The accuracy in the determination of g is

(1) 3% (2) 1%

(3) 5% (4) 2%

Answer (1)

$$\text{Sol. } g = 4\pi^2 \cdot \frac{l}{T^2}$$

$$\Rightarrow \frac{\Delta g}{g} \times 100 = \frac{\Delta l}{l} \times 100 + 2 \frac{\Delta T}{T} \times 100$$

$$= \frac{\Delta l}{l} \times 100 + 2 \cdot \frac{\Delta t}{t} \times 100$$

$$= \frac{0.1}{20.0} \times 100 + 2 \times \frac{1}{90} \times 100$$

$$= \frac{100}{200} + \frac{200}{90} = \frac{1}{2} + \frac{20}{9} \cong 3\%$$

63. A long cylindrical shell carries positive surface charge σ in the upper half and negative surface charge $-\sigma$ in the lower half. The electric field lines around the cylinder will look like figure given in

(figures are schematic and not drawn to scale)

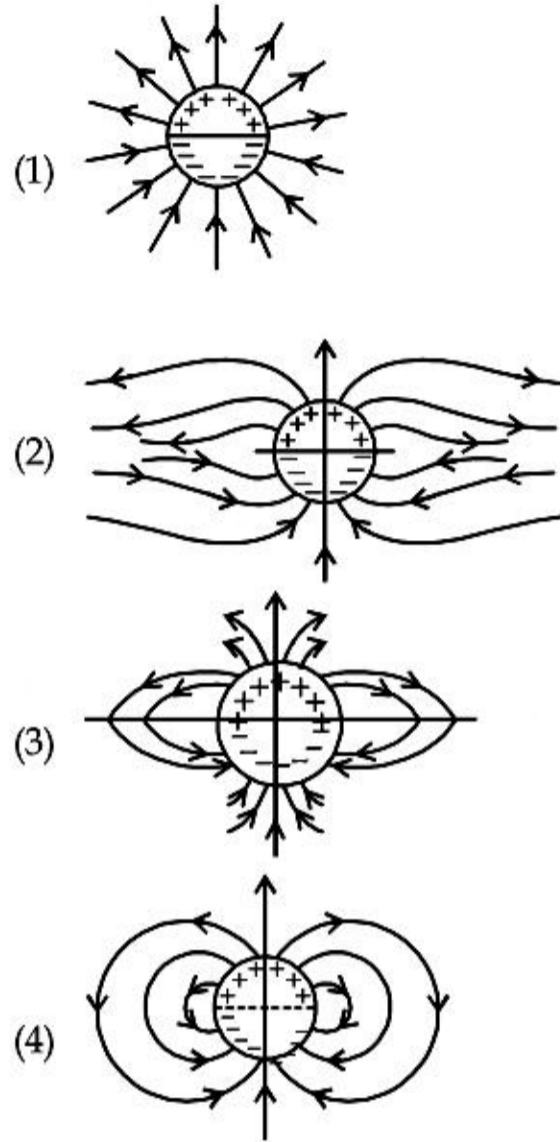

Answer (4)

Sol. The field line should resemble that of a dipole.

64. A signal of 5 kHz frequency is amplitude modulated on a carrier wave of frequency 2 MHz. The frequencies of the resultant signal is/are

- (1) 2005 kHz and 1995 kHz
- (2) 2005 kHz, 2000 kHz and 1995 kHz
- (3) 2000 kHz and 1995 kHz
- (4) 2 MHz only

Answer (2)

Sol. Frequencies of resultant signal are

$$f_c + f_m, f_c \text{ and } f_c - f_m$$

(2000 + 5) kHz, 2000 kHz, (2000 - 5) kHz,

2005 kHz, 2000 kHz, 1995 kHz

65. Consider a spherical shell of radius R at temperature T . The black body radiation inside it can be considered as an ideal gas of photons with

internal energy per unit volume $u = \frac{U}{V} \propto T^4$ and

pressure $p = \frac{1}{3} \left(\frac{U}{V} \right)$. If the shell now undergoes an

adiabatic expansion the relation between T and R is

- (1) $T \propto e^{-3R}$
- (2) $T \propto \frac{1}{R}$
- (3) $T \propto \frac{1}{R^3}$
- (4) $T \propto e^{-R}$

Answer (2)

Sol. $P = \frac{1}{3} \left(\frac{U}{V} \right) = \frac{1}{3} kT^4$... (i)

$$PV = \mu RT \quad \dots \text{(ii)}$$

$$\frac{\mu RT}{V} = \frac{1}{3} kT^4$$

$$\Rightarrow V \propto T^{-3}$$

$$R \propto \frac{1}{T}$$

66. An inductor ($L = 0.03$ H) and a resistor ($R = 0.15$ k Ω) are connected in series to a battery of 15 V, EMF in a circuit shown below. The key K_1 has been kept closed for a long time. Then at $t = 0$, K_1 is opened and key K_2 is closed simultaneously. At $t = 1$ ms, the current in the circuit will be ($e^5 \approx 150$)

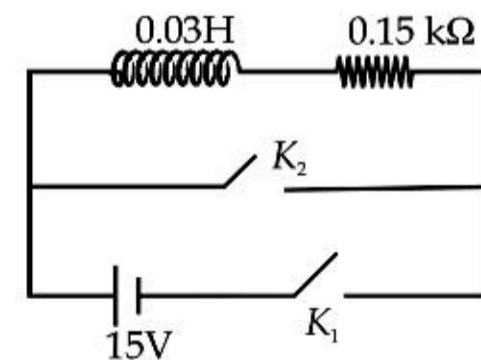

- (1) 67 mA
- (2) 6.7 mA
- (3) 0.67 mA
- (4) 100 mA

Answer (3)

Sol. $I = I_0 e^{-\frac{t}{\tau}}, \tau = \frac{L}{R}$

$$= \frac{15}{150} e^{-\frac{1 \times 10^{-3}}{1/5 \times 10^3}} = 0.67 \text{ mA}$$

67. A pendulum made of a uniform wire of cross-sectional area A has time period T . When an additional mass M is added to its bob, the time period changes to T_M . If the Young's modulus of the material of the wire is Y then $\frac{1}{Y}$ is equal to

(g = gravitational acceleration)

$$(1) \left[\left(\frac{T_M}{T} \right)^2 - 1 \right] \frac{Mg}{A}$$

$$(2) \left[1 - \left(\frac{T_M}{T} \right)^2 \right] \frac{A}{Mg}$$

$$(3) \left[1 - \left(\frac{T}{T_M} \right)^2 \right] \frac{A}{Mg}$$

$$(4) \left[\left(\frac{T_M}{T} \right)^2 - 1 \right] \frac{A}{Mg}$$

Answer (4)

$$\text{Sol. } T = 2\pi \sqrt{\frac{l}{g}} \quad \dots(1)$$

$$T_M = 2\pi \sqrt{\frac{l + \Delta l}{g}} \quad \dots(2)$$

$$Y = \frac{Fl}{A\Delta l} \Rightarrow \Delta l = \frac{Mgl}{AY} \quad \dots(3)$$

$$\Rightarrow \frac{1}{Y} = \frac{A}{Mg} \left[\left(\frac{T_M}{T} \right)^2 - 1 \right]$$

68. A red LED emits light at 0.1 watt uniformly around it. The amplitude of the electric field of the light at a distance of 1 m from the diode is

- (1) 2.45 V/m (2) 5.48 V/m
 (3) 7.75 V/m (4) 1.73 V/m

Answer (1)

$$\text{Sol. } I = \frac{P}{4\pi r^2} = U_{av} \times c \quad \dots(1)$$

$$U_{av} = \frac{1}{2} \epsilon_0 E_0^2 \quad \dots(2)$$

$$\Rightarrow \frac{P}{4\pi r^2} = \frac{1}{2} \epsilon_0 E_0^2 \times c$$

$$\Rightarrow E_0 = \sqrt{\frac{2P}{4\pi r^2 \epsilon_0 c}} = 2.45 \text{ V/m}$$

69. Two coaxial solenoids of different radii carry current I in the same direction. Let \vec{F}_1 be the magnetic force on the inner solenoid due to the outer one and \vec{F}_2 be the magnetic force on the outer solenoid due to the inner one. Then

- (1) \vec{F}_1 is radially inwards and \vec{F}_2 is radially outwards
 (2) \vec{F}_1 is radially inwards and $\vec{F}_2 = 0$
 (3) \vec{F}_1 is radially outwards and $\vec{F}_2 = 0$
 (4) $\vec{F}_1 = \vec{F}_2 = 0$

Answer (4)

Sol. Net force on each of them would be zero.

70. Consider an ideal gas confined in an isolated closed chamber. As the gas undergoes an adiabatic expansion, the average time of collision between molecules increases as V^q , where V is the volume of the gas. The value of q is

- $\left(\gamma = \frac{C_p}{C_v} \right)$
 (1) $\frac{3\gamma - 5}{6}$
 (2) $\frac{\gamma + 1}{2}$
 (3) $\frac{\gamma - 1}{2}$
 (4) $\frac{3\gamma + 5}{6}$

Answer (2)

$$\text{Sol. } \tau = \frac{\lambda}{v_{rms}} = \frac{1}{\sqrt{2}\pi d^2 \left(\frac{N}{V} \right) \sqrt{\frac{3RT}{M}}} \quad \dots(i)$$

$$\tau \propto \frac{V}{\sqrt{T}} \quad \dots(ii)$$

$$TV^{\gamma-1} = k \quad \dots(iii)$$

$$\Rightarrow \tau \propto V^{\frac{\gamma+1}{2}}$$

71. An LCR circuit is equivalent to a damped pendulum. In an LCR circuit the capacitor is charged to Q_0 and then connected to the L and R as shown below :

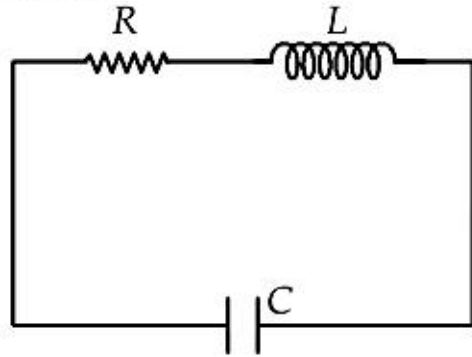

If a student plots graphs of the square of maximum charge (Q_{Max}^2) on the capacitor with time (t) for two different values L_1 and L_2 ($L_1 > L_2$) of L then which of the following represents this graph correctly? (Plots are schematic and not drawn to scale)

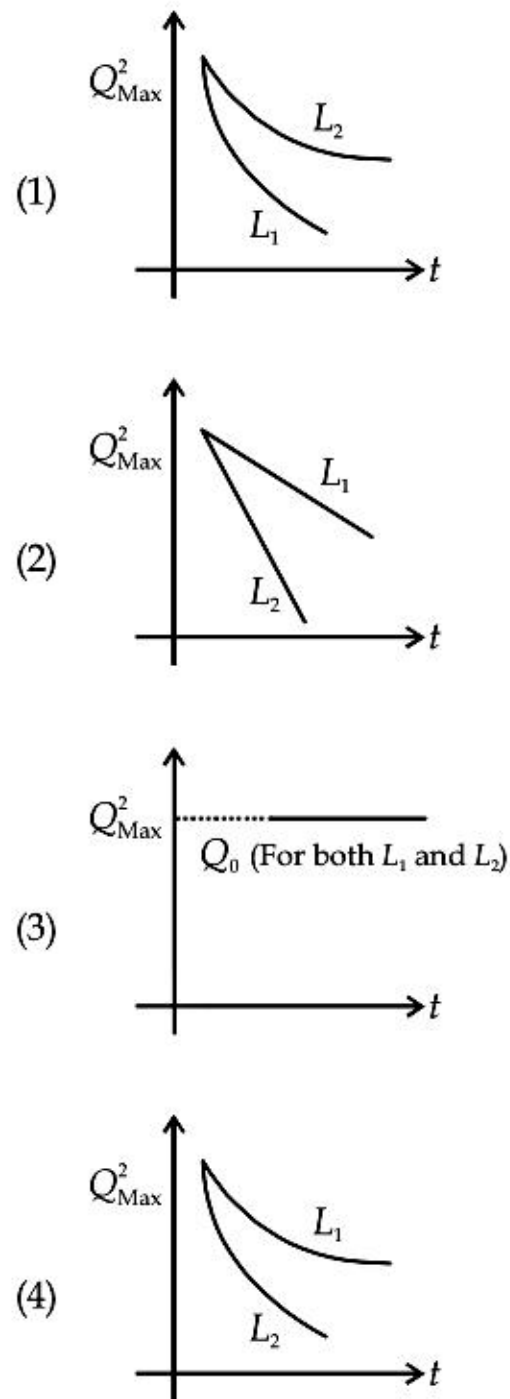

Answer (4)

Sol. For a damped pendulum, $A = A_0 e^{-bt/2m}$

$$\Rightarrow A = A_0 e^{-\left(\frac{R}{2L}\right)t}$$

(Since L plays the same role as m)

72. From a solid sphere of mass M and radius R , a spherical portion of radius $\frac{R}{2}$ is removed, as shown in the figure. Taking gravitational potential $V = 0$ at $r = \infty$, the potential at the centre of the cavity thus formed is

($G = \text{gravitational constant}$)

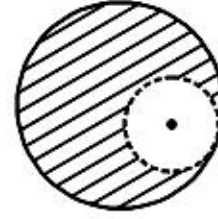

- (1) $\frac{-GM}{R}$ (2) $\frac{-2GM}{3R}$
 (3) $\frac{-2GM}{R}$ (4) $\frac{-GM}{2R}$

Answer (1)

Sol. $V = V_1 - V_2$

$$V_1 = -\frac{GM}{2R^3} \left[3R^2 - \left(\frac{R}{2}\right)^2 \right]$$

$$V_2 = -\frac{3G\left(\frac{M}{8}\right)}{2\left(\frac{R}{2}\right)}$$

$$\Rightarrow V = \frac{-GM}{R}$$

73. A train is moving on a straight track with speed 20 ms^{-1} . It is blowing its whistle at the frequency of 1000 Hz . The percentage change in the frequency heard by a person standing near the track as the train passes him is (speed of sound = 320 ms^{-1}) close to

- (1) 12% (2) 18%
 (3) 24% (4) 6%

Answer (1)

$$\text{Sol. } f_1 = f \left[\frac{v}{v - v_s} \right] = f \left[\frac{320}{320 - 20} \right] = f \times \frac{320}{300} \text{ Hz}$$

$$f_2 = f \left[\frac{v}{v + v_s} \right] = f \times \frac{320}{340} \text{ Hz}$$

$$100 \times \left(\frac{f_2}{f_1} - 1 \right) = \left(\frac{f_2 - f_1}{f_1} \right) \times 100$$

$$= 100 \left[\frac{300}{340} - 1 \right] = 12\%$$

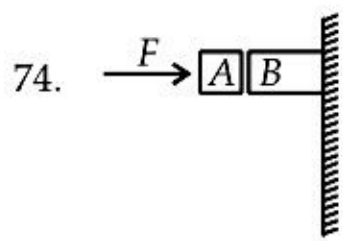

Given in the figure are two blocks A and B of weight 20 N and 100 N, respectively. These are being pressed against a wall by a force F as shown. If the coefficient of friction between the blocks is 0.1 and between block B and the wall is 0.15, the frictional force applied by the wall on block B is

- (1) 80 N (2) 120 N
 (3) 150 N (4) 100 N

Answer (2)

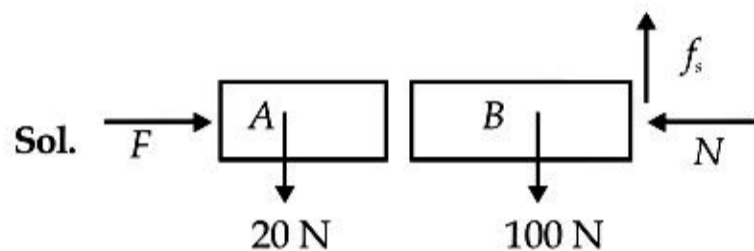

Clearly $f_s = 120$ N (for vertical equilibrium of the system)

75. Distance of the centre of mass of a solid uniform cone from its vertex is z_0 . If the radius of its base is R and its height is h then z_0 is equal to

- (1) $\frac{3h}{4}$ (2) $\frac{5h}{8}$
 (3) $\frac{3h^2}{8R}$ (4) $\frac{h^2}{4R}$

Answer (1)

Sol. $dm = \pi r^2 \cdot dy \cdot \rho$

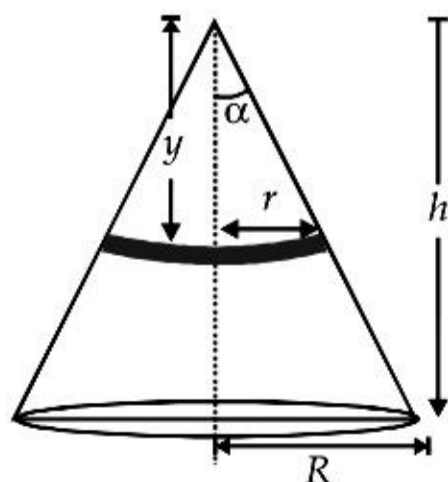

$$y_{CM} = \frac{\int y dm}{\int dm} = \frac{\int_0^h \pi r^2 dy \times \rho \times y}{\frac{1}{3} \pi R^2 h \rho}$$

$$= \frac{3h}{4}$$

76. A rectangular loop of sides 10 cm and 5 cm carrying a current I of 12 A is placed in different orientations as shown in the figures below:

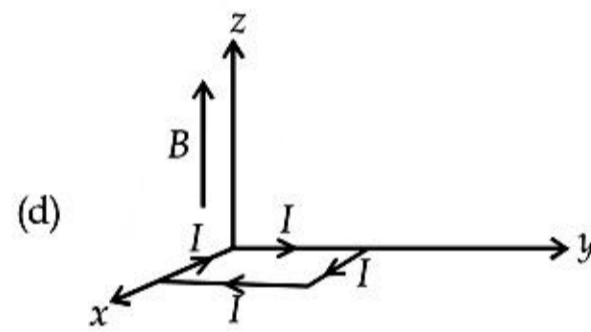
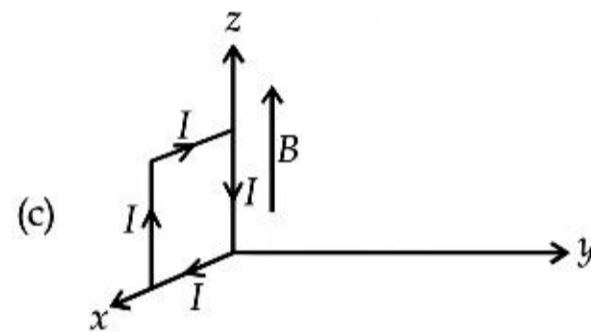
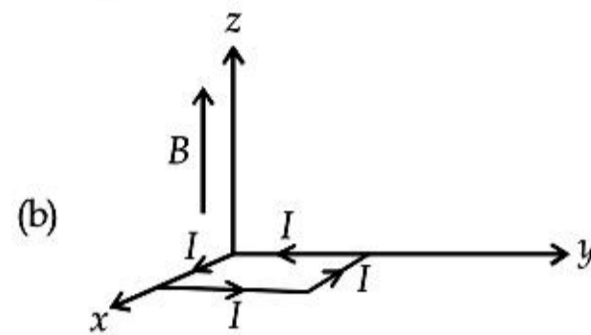
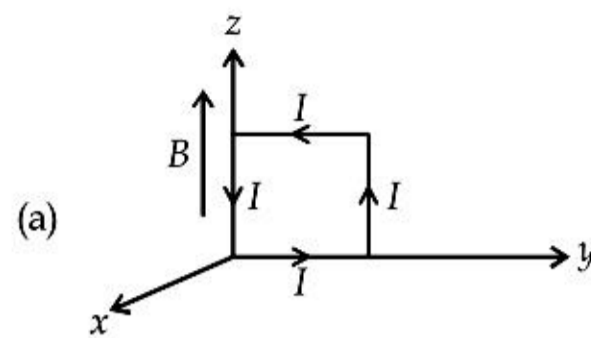

If there is a uniform magnetic field of 0.3 T in the positive z direction, in which orientations the loop would be in (i) stable equilibrium and (ii) unstable equilibrium?

- (1) (a) and (c), respectively
 (2) (b) and (d), respectively
 (3) (b) and (c), respectively
 (4) (a) and (b), respectively

Answer (2)

Sol. Stable equilibrium $\vec{M} \parallel \vec{B}$

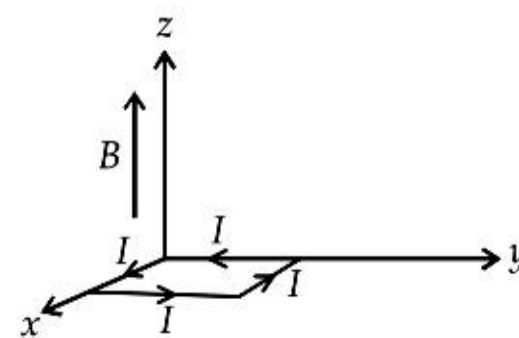

Unstable equilibrium $\vec{M} \parallel (-\vec{B})$

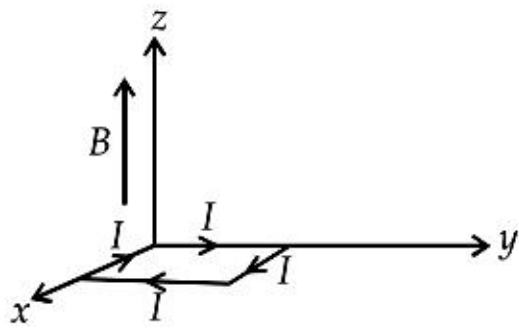

77. In the circuit shown, the current in the 1Ω resistor is

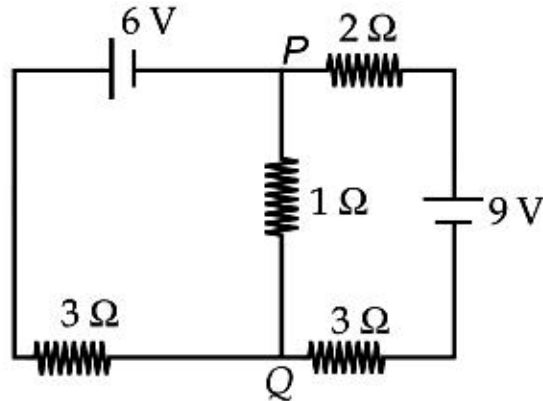

- (1) 0 A
- (2) 0.13 A, from Q to P
- (3) 0.13 A, from P to Q
- (4) 1.3 A, from P to Q

Answer (2)

Sol. From KVL,

$$9 = 6I_1 - I_2 \quad \dots(1)$$

$$6 = 4I_2 - I_1 \quad \dots(2)$$

Solving, $I_1 - I_2 = -0.13$ A

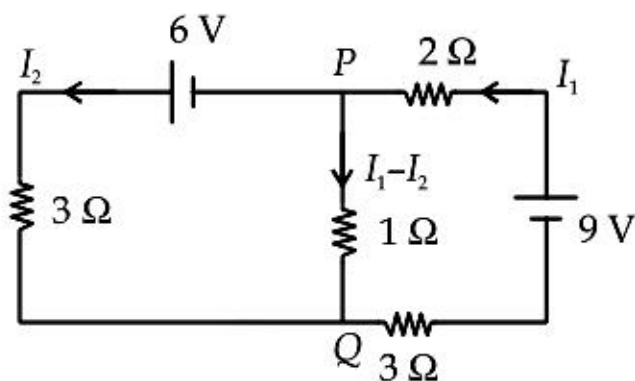

78. A uniformly charged solid sphere of radius R has potential V_0 (measured with respect to ∞) on its surface. For this sphere the equipotential surfaces with potentials $\frac{3V_0}{2}, \frac{5V_0}{4}, \frac{3V_0}{4}$ and $\frac{V_0}{4}$ have radius R_1, R_2, R_3 and R_4 respectively. Then

- (1) $R_1 \neq 0$ and $(R_2 - R_1) > (R_4 - R_3)$
- (2) $R_1 = 0$ and $R_2 < (R_4 - R_3)$
- (3) $2R < R_4$
- (4) $R_1 = 0$ and $R_2 > (R_4 - R_3)$

Answer (2, 3)

Sol. $V_0 = k \frac{Q}{R} \quad \dots(i)$

$$V_1 = \frac{kQ}{2R^3}(3R^2 - r^2)$$

$$V = \frac{3}{2}V_0 \Rightarrow R_1 = 0$$

$$\frac{5kQ}{4R} = kQ \frac{(3R^2 - r^2)}{2R^3}$$

$$\Rightarrow R_2 = \frac{R}{\sqrt{2}}$$

$$\frac{3kQ}{4R} = \frac{kQ}{R^3}$$

$$\Rightarrow R_3 = \frac{4R}{3}$$

$$\frac{1kQ}{4R} = \frac{kQ}{R_4}$$

$$\Rightarrow R_4 = 4R \Rightarrow R_4 > 2R$$

79. In the given circuit, charge Q_2 on the $2 \mu\text{F}$ capacitor changes as C is varied from $1 \mu\text{F}$ to $3 \mu\text{F}$. Q_2 as a function of C is given properly by : (Figures are drawn schematically and are not to scale)

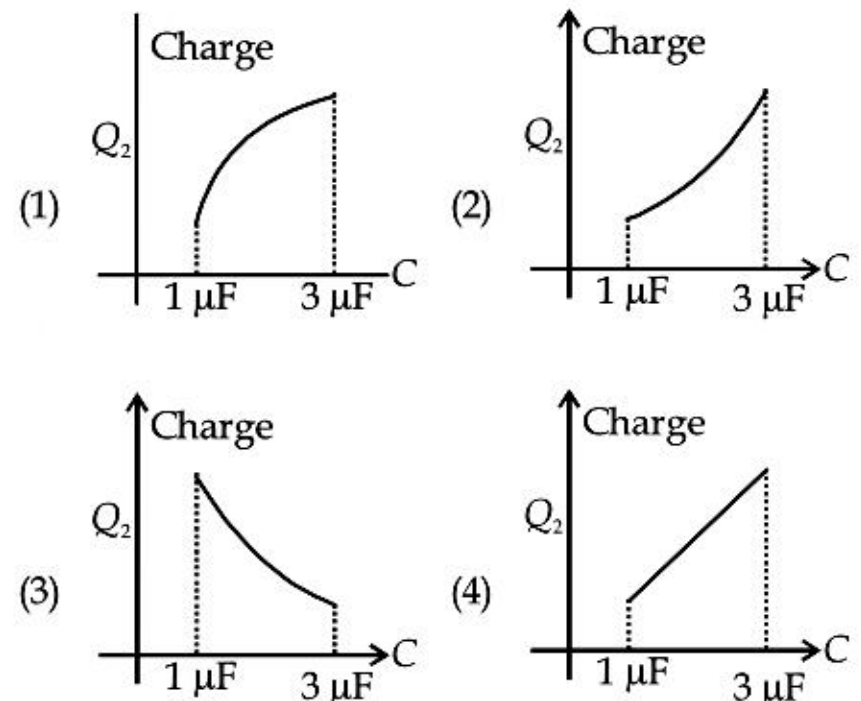
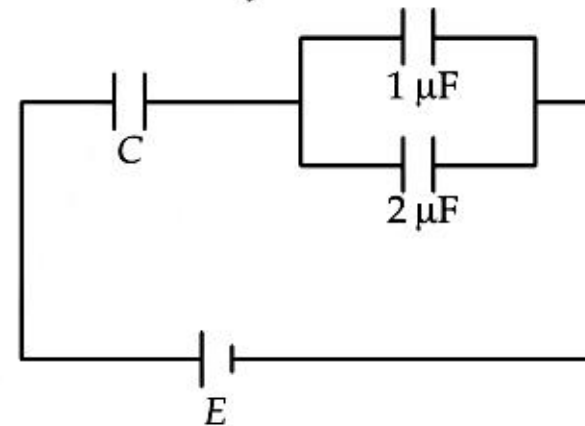

Answer (1)

Sol. $C_{\text{eq}} = \frac{3C}{3+C} \quad \dots(i)$

Total charges $q = \left(\frac{3C}{3+C} \right) E \quad \dots(ii)$

Charge upon capacitor $2 \mu\text{F}$,

$$q' = \frac{2}{3} \times \frac{3CE}{(3+C)} = \frac{2CE}{3+C} = \frac{2E}{1+\frac{3}{C}}$$

$$\text{Now, } \frac{dQ}{dC} > 0, \frac{dQ^2}{dC^2} < 0$$

80. A particle of mass m moving in the x direction with speed $2v$ is hit by another particle of mass $2m$ moving in the y direction with speed v . If the collision is perfectly inelastic, the percentage loss in the energy during the collision is close to

- (1) 50% (2) 56%
(3) 62% (4) 44%

Answer (2)

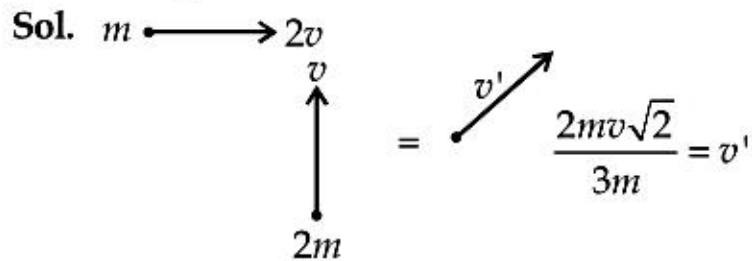

$$\text{KE loss} = \frac{1}{2}m(2v)^2 + \frac{1}{2}(2m)v^2$$

$$-\frac{1}{2} \times (3m) \left(\frac{2mv\sqrt{2}}{3m} \right)^2 = \frac{5}{3}mv^2$$

$$\text{Required \%} = \frac{\frac{5}{3}mv^2}{2mv^2 + mv^2} \times 100 = 56\%$$

81. Monochromatic light is incident on a glass prism of angle A . If the refractive index of the material of the prism is μ , a ray, incident at an angle θ , on the face AB would get transmitted through the face AC of the prism provided.

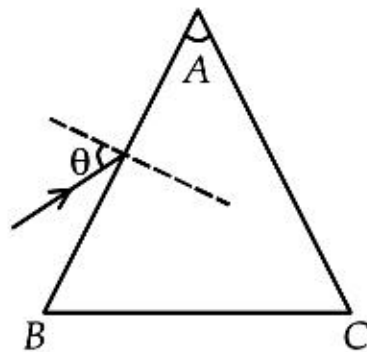

- (1) $\theta < \sin^{-1} \left[\mu \sin \left(A - \sin^{-1} \left(\frac{1}{\mu} \right) \right) \right]$
 (2) $\theta > \cos^{-1} \left[\mu \sin \left(A + \sin^{-1} \left(\frac{1}{\mu} \right) \right) \right]$
 (3) $\theta < \cos^{-1} \left[\mu \sin \left(A + \sin^{-1} \left(\frac{1}{\mu} \right) \right) \right]$
 (4) $\theta > \sin^{-1} \left[\mu \sin \left(A - \sin^{-1} \left(\frac{1}{\mu} \right) \right) \right]$

Answer (4)

Sol.

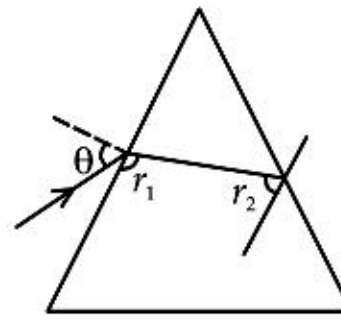

$$\sin \theta = \mu \sin r_1$$

$$\Rightarrow \sin r_1 = \frac{\sin \theta}{\mu}$$

$$\Rightarrow r_1 = \sin^{-1} \left(\frac{\sin \theta}{\mu} \right)$$

$$r_2 = A - \sin^{-1} \left(\frac{\sin \theta}{\mu} \right)$$

$$\Rightarrow r_2 < \sin^{-1} \left(\frac{1}{\mu} \right)$$

$$A - \sin^{-1} \left(\frac{\sin \theta}{\mu} \right) < \sin^{-1} \left(\frac{1}{\mu} \right)$$

$$\Rightarrow A - \sin^{-1} \left(\frac{1}{\mu} \right) < \sin^{-1} \left(\frac{\sin \theta}{\mu} \right)$$

$$\Rightarrow \sin \left(A - \sin^{-1} \left(\frac{1}{\mu} \right) \right) < \frac{\sin \theta}{\mu}$$

$$\Rightarrow \mu \left(\sin \left(A - \sin^{-1} \left(\frac{1}{\mu} \right) \right) \right) < \sin \theta$$

$$\Rightarrow \sin^{-1} \left(\mu \sin \left(A - \sin^{-1} \left(\frac{1}{\mu} \right) \right) \right) < \theta$$

82. From a solid sphere of mass M and radius R a cube of maximum possible volume is cut. Moment of inertia of cube about an axis passing through its center and perpendicular to one of its faces is

- (1) $\frac{MR^2}{16\sqrt{2}\pi}$ (2) $\frac{4MR^2}{9\sqrt{3}\pi}$
 (3) $\frac{4MR^2}{3\sqrt{3}\pi}$ (4) $\frac{MR^2}{32\sqrt{2}\pi}$

Answer (2)

Sol. $d = 2R = a\sqrt{3}$

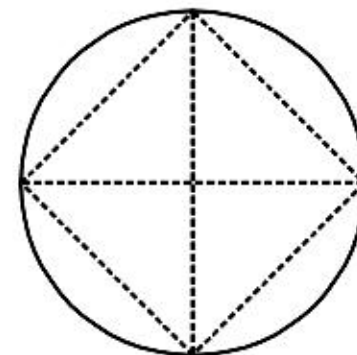

$$\Rightarrow a = \frac{2}{\sqrt{3}}R$$

$$\frac{M}{M'} = \frac{\frac{4}{3}\pi R^3}{\left(\frac{2}{\sqrt{3}}R\right)^3} = \frac{\sqrt{3}}{2}\pi$$

$$\Rightarrow M' = \frac{2M}{\sqrt{3}\pi}$$

$$I = \frac{M'a^2}{6} = \frac{2M}{\sqrt{3}\pi} \times \frac{4}{3}R^2 \times \frac{1}{6}$$

$$I = \frac{4MR^2}{9\sqrt{3}\pi}$$

83. Match List-I (Fundamental Experiment) with List-II (its conclusion) and select the correct option from the choices given below the list:

	List - I		List-II
(A)	Franck-Hertz experiment	(i)	Particle nature of light
(B)	Photo-electric experiment	(ii)	Discrete energy levels of atom
(C)	Davison-Germer experiment	(iii)	Wave nature of electron
		(iv)	Structure of atom

- (1) (A) - (ii) (B) - (iv) (C) - (iii)
 (2) (A) - (ii) (B) - (i) (C) - (iii)
 (3) (A) - (iv) (B) - (iii) (C) - (ii)
 (4) (A) - (i) (B) - (iv) (C) - (iii)

Answer (2)

- Sol.** Franck-Hertz exp.- Discrete energy level.
 Photo-electric effect- Particle nature of light
 Davison-Germer exp.- Diffraction of electron beam.
84. When 5 V potential difference is applied across a wire of length 0.1 m, the drift speed of electrons is $2.5 \times 10^{-4} \text{ ms}^{-1}$. If the electron density in the wire is $8 \times 10^{28} \text{ m}^{-3}$, the resistivity of the material is close to

- (1) $1.6 \times 10^{-7} \Omega\text{m}$
 (2) $1.6 \times 10^{-6} \Omega\text{m}$
 (3) $1.6 \times 10^{-5} \Omega\text{m}$
 (4) $1.6 \times 10^{-8} \Omega\text{m}$

Answer (3)

Sol. $V = IR = I\rho \frac{l}{A}$

$$\Rightarrow \rho = \frac{VA}{Il} = \frac{VA}{lneAv_d} = \frac{V}{l \times n \times e \times v_d}$$

$$\Rightarrow \rho = \frac{5}{0.1 \times 2.5 \times 10^{-19} \times 1.6 \times 10^{-19} \times 8 \times 10^{28}}$$

$$= 1.6 \times 10^{-5} \Omega\text{m}$$

85. For a simple pendulum, a graph is plotted between its kinetic energy (KE) and potential energy (PE) against its displacement d . Which one of the following represents these correctly?

(Graphs are schematic and not drawn to scale)

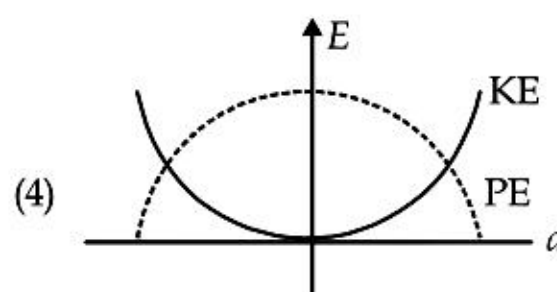
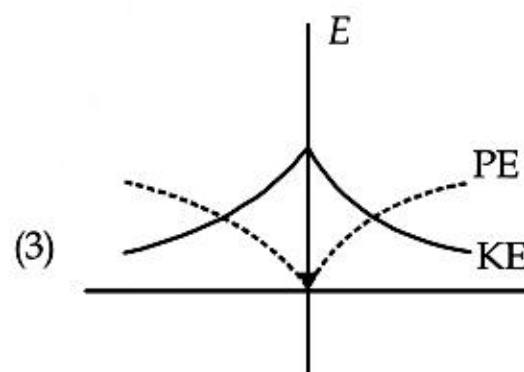
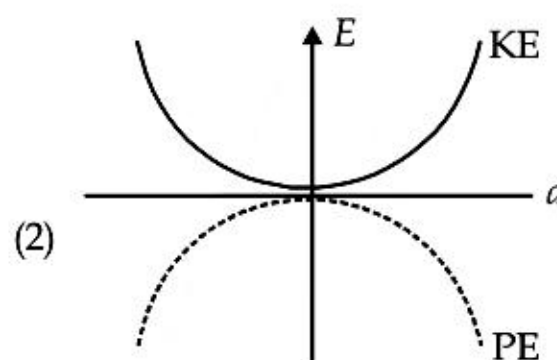
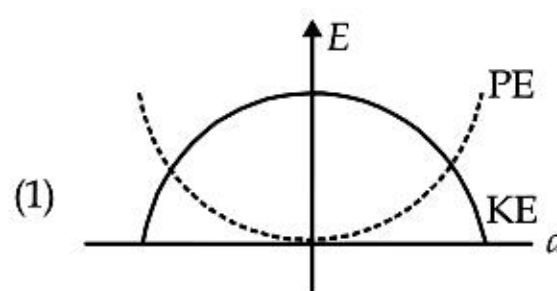

Answer (1)

Sol. $\text{KE} = \frac{1}{2}m\omega^2(A^2 - d^2)$

$$\text{PE} = \frac{1}{2}m\omega^2 d^2$$

At $d = \pm A$,

PE = maximum while KE = 0.

86. Two stones are thrown up simultaneously from the edge of a cliff 240 m high with initial speed of 10 m/s and 40 m/s respectively. Which of the following graph best represents the time variation of relative position of the second stone with respect to the first?

(Assume stones do not rebound after hitting the ground and neglect air resistance, take $g = 10 \text{ m/s}^2$)

(The figures are schematic and not drawn to scale)

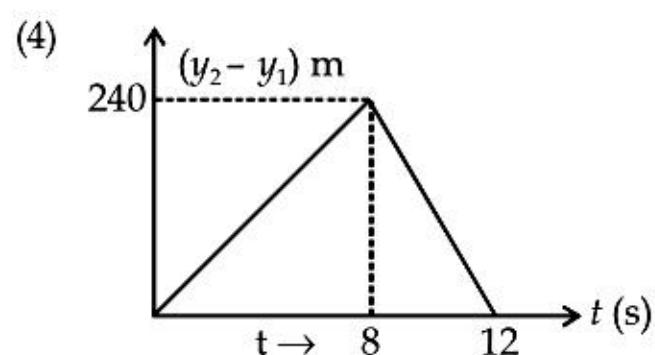
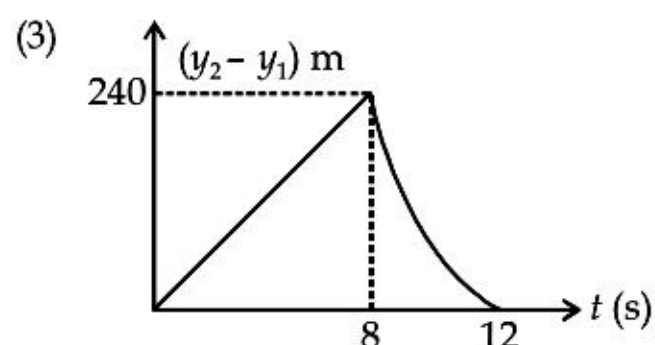
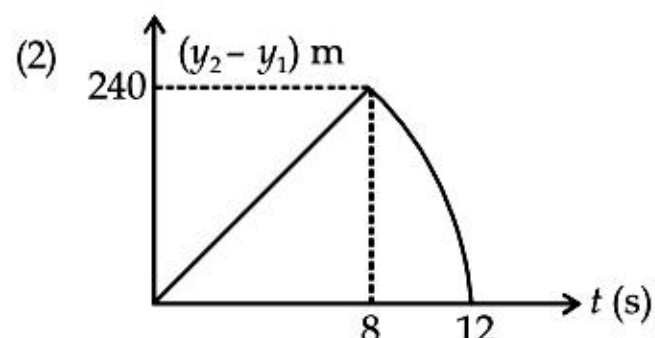
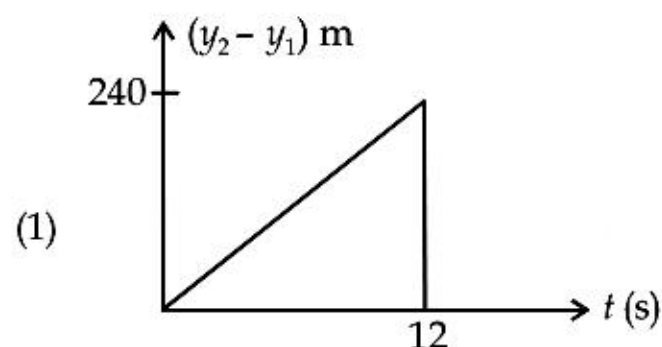

Answer (2)

Sol. Till both are in air (From $t = 0$ to $t = 8$ sec)

$$\Delta x = x_2 - x_1 = 30t$$

$$\Rightarrow \Delta x \propto t$$

When second stone hits ground and first stone is in air Δx decreases.

87. A solid body of constant heat capacity $1 \text{ J/}^\circ\text{C}$ is being heated by keeping it in contact with reservoirs in two ways :

- Sequentially keeping in contact with 2 reservoirs such that each reservoir supplies same amount of heat.
- Sequentially keeping in contact with 8 reservoirs such that each reservoir supplies same amount of heat.

In both the cases body is brought from initial temperature 100°C to final temperature 200°C . Entropy change of the body in the two cases respectively is

- $\ln 2, \ln 2$
- $\ln 2, 2\ln 2$
- $2\ln 2, 8\ln 2$
- $\ln 2, 4\ln 2$

Answer (None)

Sol. $ds' = \frac{dQ}{T} = ms \frac{dT}{T}$

$$\Delta s' = \int ds' = ms \int \frac{dT}{T} = 1 \log_e \frac{T_2}{T_1} = \log_e \frac{473}{373}$$

88. Assuming human pupil to have a radius of 0.25 cm and a comfortable viewing distance of 25 cm, the minimum separation between two objects that human eye can resolve at 500 nm wavelength is

- $30 \mu\text{m}$
- $100 \mu\text{m}$
- $300 \mu\text{m}$
- $1 \mu\text{m}$

Answer (1)

Sol. $RP = \frac{1.22\lambda}{2\mu \sin \theta} = \frac{1.22 \times (500 \times 10^{-9} \text{ m})}{2 \times 1 \times \left(\frac{1}{100}\right)}$

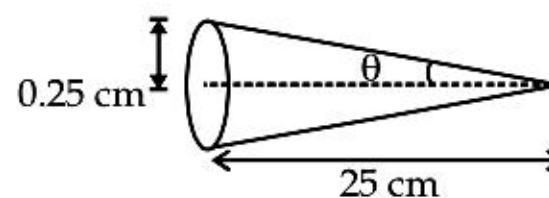

$$= 3.05 \times 10^{-5} \text{ m}$$

$$= 30 \mu\text{m}$$

89. Two long current carrying thin wires, both with current I , are held by insulating threads of length L and are in equilibrium as shown in the figure, with threads making an angle θ with the vertical. If wires have mass λ per unit length then the value of I is (g = gravitational acceleration)

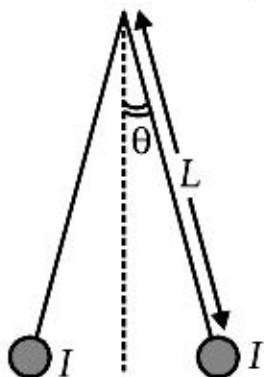

(1) $2 \sin \theta \sqrt{\frac{\pi \lambda g L}{\mu_0 \cos \theta}}$

(2) $2 \sqrt{\frac{\pi g L}{\mu_0}} \tan \theta$

(3) $\sqrt{\frac{\pi \lambda g L}{\mu_0}} \tan \theta$

(4) $\sin \theta \sqrt{\frac{\pi \lambda g L}{\mu_0 \cos \theta}}$

Answer (1)

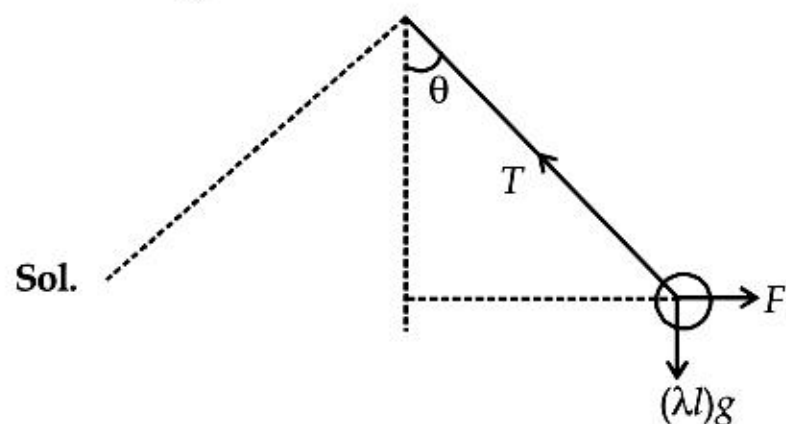

$$T \cos \theta = \lambda g l \quad \dots(1)$$

$$T \sin \theta = \frac{\mu_0}{2\pi} \cdot \frac{I \times I l}{(2L \sin \theta)} \quad \dots(2)$$

$$\Rightarrow I = 2 \sin \theta \sqrt{\frac{\pi \lambda g L}{\mu_0 \cos \theta}}$$

90. On a hot summer night, the refractive index of air is smallest near the ground and increases with height from the ground. When a light beam is directed horizontally, the Huygen's principle leads us to conclude that as it travels, the light beam

- (1) Goes horizontally without any deflection
- (2) Bends downwards
- (3) Bends upwards
- (4) Becomes narrower

Answer (3)

Sol. Consider a plane wavefront travelling horizontally. As it moves, its different parts move with different speeds. So, its shape will change as shown

\Rightarrow Light bends upward

