

Andhra Pradesh State Council of Higher Education

Notations :

- 1.Options shown in **green** color and with **✓** icon are correct.
- 2.Options shown in **red** color and with **✗** icon are incorrect.

Question Paper Name :	Electrical and Electronics Engineering 19th Sep 2021 Shift1
Duration :	180
Total Marks :	200
Display Marks:	No
Calculator :	None
Magnifying Glass Required? :	No
Ruler Required? :	No
Eraser Required? :	No
Scratch Pad Required? :	No
Rough Sketch/Notepad Required? :	No
Protractor Required? :	No
Show Watermark on Console? :	Yes
Highlighter :	No
Auto Save on Console? (SA type of questions will be always auto saved) :	Yes
Is this Group for Examiner? :	No

Mathematics

Section Id :	477203374
Section Number :	1
Mandatory or Optional :	Mandatory
Number of Questions :	50
Section Marks :	50
Enable Mark as Answered Mark for Review and Clear Response :	Yes

Question Number : 1 Question Id : 47720319029 Display Question Number : Yes Is Question Mandatory : No

If $A = \begin{bmatrix} 1 & 2 \\ 3 & 4 \end{bmatrix}$ and $B = \begin{bmatrix} 5 & 6 \\ 7 & 8 \end{bmatrix}$ then $AB^T =$

Options :

1. ✘ $\begin{bmatrix} 19 & 22 \\ 43 & 50 \end{bmatrix}$

2. ✔ $\begin{bmatrix} 17 & 23 \\ 39 & 53 \end{bmatrix}$

3. ✘ $\begin{bmatrix} 26 & 38 \\ 30 & 44 \end{bmatrix}$

4. ✘ $\begin{bmatrix} 19 & 23 \\ 30 & 53 \end{bmatrix}$

Question Number : 2 Question Id : 47720319030 Display Question Number : Yes Is Question Mandatory : No

If A is any square matrix, then $A - A^T$ is

Options :

1. ✘ a null matrix
2. ✘ an identity matrix
3. ✘ a symmetric matrix
4. ✔ a skew-symmetric matrix

Question Number : 3 Question Id : 47720319031 Display Question Number : Yes Is Question Mandatory : No

$$\text{If } \begin{vmatrix} 4 & -5 & 6 \\ 7 & x & 8 \\ -1 & 2 & -3 \end{vmatrix} = 0, \text{ then, } x =$$

Options :

1. ✘ 0
2. ✘ $-\frac{55}{6}$
3. ✔ $-\frac{15}{2}$
4. ✘ 1

Question Number : 4 Question Id : 47720319032 Display Question Number : Yes Is Question

Mandatory : No

If $A = \begin{bmatrix} 3 & -5 \\ -7 & 2 \end{bmatrix}$, $I = \begin{bmatrix} 1 & 0 \\ 0 & 1 \end{bmatrix}$ and B is a square matrix such that $AB = I$, then, $B =$

Options :

1. ✘ $\begin{bmatrix} 2 & 5 \\ 7 & 3 \end{bmatrix}$

2. ✘ $\begin{bmatrix} -2 & 5 \\ 7 & -3 \end{bmatrix}$

3. ✔ $-\frac{1}{29} \begin{bmatrix} 2 & 5 \\ 7 & 3 \end{bmatrix}$

4. ✘ $-\frac{1}{29} \begin{bmatrix} -2 & 5 \\ 7 & -3 \end{bmatrix}$

Question Number : 5 Question Id : 47720319033 Display Question Number : Yes Is Question

Mandatory : No

If $x = \alpha$, $y = \beta$, $z = \gamma$ is the unique solution of the system of simultaneous linear equations $x - 2y + z = 5$, $2x + y - 2z = -3$ and $x - 2y + 3z = 9$, then, $\gamma =$

Options :

1. ✔ 2

2. ✘ -2

3. ✘ -3

4. ✘ 3

Question Number : 6 Question Id : 47720319034 Display Question Number : Yes Is Question

Mandatory : No

$$\text{If } \frac{4x-22}{3x^2+2x-8} = \frac{A}{x+2} + \frac{B}{3x-4}, \text{ then, } A+B =$$

Options :

1. ✔ -2

2. ✘ 0

3. ✘ 2

4. ✘ 4

Question Number : 7 Question Id : 47720319035 Display Question Number : Yes Is Question

Mandatory : No

$$\text{If } \frac{4-7x^2}{3x^3+6x^2} = \frac{A}{x} + \frac{Bx+C}{x^2+2}, \text{ then, } A+C =$$

Options :

1. ✘ 0

2. ✔ $\frac{2}{3}$

3. ✘

$$\frac{3}{2}$$

4. ✘ 2

Question Number : 8 Question Id : 47720319036 Display Question Number : Yes Is Question

Mandatory : No

If $\tan \theta = -\frac{4}{3}$ and θ is not in the second quadrant, then, $\cos \theta + \csc \theta =$

Options :

1. ✔ $-\frac{13}{20}$

2. ✘ $-\frac{1}{5}$

3. ✘ $\frac{27}{20}$

4. ✘ $\frac{7}{5}$

Question Number : 9 Question Id : 47720319037 Display Question Number : Yes Is Question

Mandatory : No

The sine function, whose period is $\frac{4}{5}$, is

Options :

1. ✘

$$\sin \frac{5\pi}{4} x$$

$$\sin \frac{4\pi}{5} x$$

2. ✘

$$\sin \frac{5\pi}{2} x$$

3. ✔

$$\sin \frac{2\pi}{5} x$$

4. ✘

Question Number : 10 Question Id : 47720319038 Display Question Number : Yes Is Question Mandatory : No

If $A+B = \frac{3\pi}{4}$, then, $(1 - \tan A)(1 - \tan B) =$

Options :

1. ✘ 0

2. ✘ 1

3. ✔ 2

4. ✘ -2

Question Number : 11 Question Id : 47720319039 Display Question Number : Yes Is Question

Mandatory : No

If $0 < A < \frac{\pi}{4}$ and $\sin A = \frac{3}{5}$, then, $\sin 2A + \cos 2A =$

Options :

1. ✘ $\frac{17}{25}$

2. ✘ $\frac{24}{25}$

3. ✘ $\frac{9}{25}$

4. ✔ $\frac{31}{25}$

Question Number : 12 Question Id : 47720319040 Display Question Number : Yes Is Question

Mandatory : No

$\cos 56^\circ + \sin 26^\circ - \sin 86^\circ =$

Options :

1. ✘ -1

2. ✔ 0

3. ✘ 1

4. ✘ 2

Question Number : 13 Question Id : 47720319041 Display Question Number : Yes Is Question Mandatory : No

The general solution of the trigonometric equation $\sec x = 4 \cos x$ is $x =$

Options :

1. ✓ $2n\pi \pm \frac{\pi}{3}$ or $2n\pi \pm \frac{2\pi}{3}$

2. ✗ $2n\pi \pm \frac{\pi}{6}$ or $2n\pi \pm \frac{5\pi}{6}$

3. ✗ $2n\pi \pm \frac{\pi}{4}$ or $2n\pi \pm \frac{3\pi}{4}$

4. ✗ $n\pi + (-1)^n \frac{\pi}{3}$ or $n\pi + (-1)^n \frac{2\pi}{3}$

Question Number : 14 Question Id : 47720319042 Display Question Number : Yes Is Question Mandatory : No

The general solution of the trigonometric equation $\cos 4\theta = \cos 3\theta$ is $\theta =$

Options :

1. ✗ $n\pi + \frac{\pi}{6}$

2. ✗ $2n\pi + \frac{\pi}{3}$

3. ✓ $\frac{2n\pi}{7}$ or $2n\pi$

$$\frac{n\pi}{7} \text{ or } n\pi$$

4. ✖

Question Number : 15 Question Id : 47720319043 Display Question Number : Yes Is Question Mandatory : No

$$\cos \left[\frac{\pi}{2} + \cos^{-1} \left(-\frac{3}{5} \right) \right] =$$

Options :

1. ✖ $\frac{4}{5}$

2. ✖ $\frac{3}{5}$

3. ✔ $-\frac{4}{5}$

4. ✖ $-\frac{3}{5}$

Question Number : 16 Question Id : 47720319044 Display Question Number : Yes Is Question Mandatory : No

$$\cot \left[\tan^{-1} \left(\frac{1}{6} \right) + \tan^{-1} \left(\frac{5}{7} \right) \right] =$$

Options :

1. ✖

0

2. ✘ $\frac{1}{\sqrt{3}}$

3. ✔ 1

4. ✘ $\sqrt{3}$

Question Number : 17 Question Id : 47720319045 Display Question Number : Yes Is Question Mandatory : No

In a triangle ABC, if $b = 3$, $c = 4$ and $\cos A = \frac{7}{8}$, then, $a =$

Options :

1. ✘ 5

2. ✔ 2

3. ✘ 6

4. ✘ 8

Question Number : 18 Question Id : 47720319046 Display Question Number : Yes Is Question Mandatory : No

If $i^2 = -1$, then, $(1 - i)^{2020} =$

Options :

1. ✓ -2^{1010}

2. ✗ 2^{1010}

3. ✗ 2^{2020}

4. ✗ -2^{2020}

Question Number : 19 Question Id : 47720319047 Display Question Number : Yes Is Question

Mandatory : No

If $i^2 = -1$, then, $(\sqrt{3} + i)^4 + (\sqrt{3} - i)^4 =$

Options :

1. ✗ 32

2. ✗ -32

3. ✗ 16

4. ✓ -16

Question Number : 20 Question Id : 47720319048 Display Question Number : Yes Is Question

Mandatory : No

If (1,2) and (2,1) are the ends of one of the diameters of a circle, then the equation of the circle is

Options :

1. ✘ $x^2 + y^2 - 3x - 3y - 4 = 0$

2. ✘ $x^2 + y^2 - 3x + 3y - 4 = 0$

3. ✘ $x^2 + y^2 + 3x - 3y - 4 = 0$

4. ✔ $x^2 + y^2 - 3x - 3y + 4 = 0$

Question Number : 21 Question Id : 47720319049 Display Question Number : Yes Is Question Mandatory : No

The equation of the circle of radius 2 with its centre at (2,2) is

Options :

1. ✔ $x^2 + y^2 - 4x - 4y + 4 = 0$

2. ✘ $x^2 + y^2 + 4x + 4y + 4 = 0$

3. ✘ $x^2 + y^2 - 4x - 4y + 12 = 0$

4. ✘ $x^2 + y^2 + 4x + 4y + 12 = 0$

Question Number : 22 Question Id : 47720319050 Display Question Number : Yes Is Question

Mandatory : No

If the centre of the circle $x^2 + y^2 - 6x + ky + 9 = 0$ lies on the line $2x + y - 4 = 0$, then, the radius of that circle is

Options :

1. ✘ 1

2. ✔ 2

3. ✘ 3

4. ✘ 4

Question Number : 23 Question Id : 47720319051 Display Question Number : Yes Is Question

Mandatory : No

Distance from the focus of the parabola $y^2 = 8x$ to the point $(2,4)$ on it is

Options :

1. ✘ 1

2. ✘ 2

3. ✘ 3

4. ✔ 4

Question Number : 24 Question Id : 47720319052 Display Question Number : Yes Is Question

Mandatory : No

If e is the eccentricity and a is the length of the semi-minor axis of the ellipse $9x^2 + 4y^2 = 36$, then, $e^2 + a^2 =$

Options :

1. ✓ $\frac{41}{9}$

2. ✗ $\frac{23}{9}$

3. ✗ $\frac{17}{3}$

4. ✗ $\frac{11}{3}$

Question Number : 25 Question Id : 47720319053 Display Question Number : Yes Is Question

Mandatory : No

One of the foci of the hyperbola $\frac{x^2}{9} - \frac{y^2}{16} = -1$ is

Options :

1. ✗ (5,0)

2. ✓ (0,5)

3. ✗ (4,0)

4. ✗ (0,3)

Question Number : 26 Question Id : 47720319054 Display Question Number : Yes Is Question

Mandatory : No

$$\lim_{x \rightarrow 0} \frac{2^x - 1}{\sqrt{2+x} - \sqrt{2}} =$$

Options :

$$\sqrt{2} \log 2$$

1. ✘

$$2 \log 2$$

2. ✘

$$2\sqrt{2} \log 2$$

3. ✔

$$\text{Log } 2$$

4. ✘

Question Number : 27 Question Id : 47720319055 Display Question Number : Yes Is Question

Mandatory : No

$$\text{If } y = \sqrt{\frac{2+x^2}{2-x^2}}, \text{ then, } \frac{dy}{dx} =$$

Options :

$$\frac{4x}{(2-x^2)\sqrt{4-x^4}}$$

1. ✔

$$\frac{4x}{(2-x^2)\sqrt{4-x^2}}$$

2. ✘

3. ✘

$$\frac{4x}{(4-x^2)\sqrt{2-x^4}}$$

4. ✘ $\frac{2x}{(2-x^2)\sqrt{4-x^4}}$

Question Number : 28 Question Id : 47720319056 Display Question Number : Yes Is Question Mandatory : No

If $2x^2 - 3xy + y^2 - 4x + 6y - 7 = 0$, then, $\frac{dy}{dx} =$

Options :

1. ✘ $\frac{-4x - 3y + 4}{3x + 2y + 6}$

2. ✔ $\frac{4x - 3y - 4}{3x - 2y - 6}$

3. ✘ $\frac{4x + 3y + 4}{3x - 2y - 6}$

4. ✘ $\frac{4x - 3y - 4}{3x + 2y - 6}$

Question Number : 29 Question Id : 47720319057 Display Question Number : Yes Is Question Mandatory : No

If the radius of a sphere is increased from 5 cm to 5.03 cm, then, the approximate relative error in its surface area is

Options :

1. ✓ 0.012

2. ✗ 0.06

3. ✗ 0.08

4. ✗ 0.1

Question Number : 30 Question Id : 47720319058 Display Question Number : Yes Is Question Mandatory : No

The equation of the normal at (1,1) to the curve $y = 2x^3 - 3x^2 + x + 1$ is

Options :

1. ✓ $x + y - 2 = 0$

2. ✗ $x - y = 0$

3. ✗ $2x - 3y + 1 = 0$

4. ✗ $x - 2y + 1 = 0$

Question Number : 31 Question Id : 47720319059 Display Question Number : Yes Is Question Mandatory : No

The angle between the curves $x^2 + y^2 = 2$ and $y^2 = x$ is

Options :

1. ✓ $\text{Tan}^{-1}(3)$

2. ✗ $\text{Tan}^{-1}(2)$

3. ✗ $\frac{\pi}{4}$

4. ✗ $\frac{\pi}{2}$

Question Number : 32 Question Id : 47720319060 Display Question Number : Yes Is Question Mandatory : No

If the volume of a cube is increasing at the rate of 5 cu. cm./sec , the rate of change in the length of the edge of the cube, when the length of the edge is 5 cm., is

Options :

1. ✗ $\frac{1}{15}$ sq. cm. /sec

2. ✗ 15 cm. /sec

3. ✓ $\frac{1}{15}$ cm. /sec

4. ✗ $\frac{1}{3}$ cm. /sec

Question Number : 33 Question Id : 47720319061 Display Question Number : Yes Is Question

Mandatory : No

The interval in which the function $f(x) = 2x^3 - 9x^2 + 12x - 6$ is strictly increasing is

Options :

1. ✘ (1,2)
2. ✘ [1,2]
3. ✘ $(-\infty, 1] \cup [2, \infty)$
4. ✔ $(-\infty, 1) \cup (2, \infty)$

Question Number : 34 Question Id : 47720319062 Display Question Number : Yes Is Question

Mandatory : No

If the perimeter of a rectangle is 40 units, then the area of that rectangle is maximum when its dimensions are

Options :

1. ✘ 14, 6
2. ✘ 22, 18
3. ✔ 10, 10
4. ✘ 20, 20

Question Number : 35 Question Id : 47720319063 Display Question Number : Yes Is Question

Mandatory : No

If $u = \frac{x^2+y^2}{x-y}$, then, $\frac{\partial u}{\partial x} + \frac{\partial u}{\partial y} =$

Options :

1. ✘ 0

2. ✘ u

3. ✔ $2\left(\frac{x+y}{x-y}\right)$

4. ✘ 2u

Question Number : 36 Question Id : 47720319064 Display Question Number : Yes Is Question Mandatory : No

$$\int \frac{x^2 + 2x - 1}{\sqrt{x^3 + 3x^2 - 3x + 6}} dx =$$

Options :

1. ✔ $\frac{2}{3}\sqrt{x^3 + 3x^2 - 3x + 6} + c$

2. ✘ $\frac{1}{3}\sqrt{x^3 + 3x^2 - 3x + 6} + c$

3. ✘ $\frac{2}{3\sqrt{x^3 + 3x^2 - 3x + 6}} + c$

$$\frac{1}{6\sqrt{x^3 + 3x^2 - 3x + 6}} + c$$

4. ✖

Question Number : 37 Question Id : 47720319065 Display Question Number : Yes Is Question Mandatory : No

$$\int e^{2x} \sec 2x (1 + \tan 2x) dx =$$

Options :

1. ✖ $e^{2x} \sec 2x + c$

2. ✖ $e^{2x} \tan 2x + c$

3. ✔ $\frac{1}{2} e^{2x} \sec 2x + c$

4. ✖ $2e^{2x} \sec 2x + c$

Question Number : 38 Question Id : 47720319066 Display Question Number : Yes Is Question Mandatory : No

$$\int \frac{dx}{\sqrt{x^2 - 2x + 5}} =$$

Options :

1. ✖ $\text{Tanh}^{-1} \left(\frac{x-1}{2} \right) + c$

2. ✘ $\text{Sinh}^{-1}(x - 1) + c$

3. ✘ $\text{Cosh}^{-1}\left(\frac{x - 1}{2}\right) + c$

4. ✔ $\text{Sinh}^{-1}\left(\frac{x - 1}{2}\right) + c$

Question Number : 39 Question Id : 47720319067 Display Question Number : Yes Is Question Mandatory : No

$$\int_{-2}^2 \frac{x^2}{x - 1} dx =$$

Options :

1. ✘ $8 + \log \frac{1}{3}$

2. ✔ $4 - \log 3$

3. ✘ $2 - \log 3$

4. ✘ $4 + \log 3$

Question Number : 40 Question Id : 47720319068 Display Question Number : Yes Is Question Mandatory : No

The area enclosed between the X-axis and the curve $y = (x - 2)^2 - 9$ is

Options :

1. ✘ 54

2. ✘ $\frac{320}{3}$

3. ✔ 36

4. ✘ $\frac{124}{3}$

Question Number : 41 Question Id : 47720319069 Display Question Number : Yes Is Question

Mandatory : No

The volume formed when the area bounded by the parabola $y^2 = 8x$, the X-axis and the ordinates at $x = 0$ and $x = 2$ rotates about the X-axis is (in cubic units)

Options :

1. ✘ 4π

2. ✘ 8π

3. ✘ 32π

4. ✔ 16π

Question Number : 42 Question Id : 47720319070 Display Question Number : Yes Is Question

Mandatory : No

Mean value of $\frac{1}{4+x^2}$ on $[-2,2]$ is

Options :

1. ✘ $\frac{\pi}{4}$

2. ✘ $\frac{\pi}{8}$

3. ✘ $\frac{\pi}{32}$

4. ✔ $\frac{\pi}{16}$

Question Number : 43 Question Id : 47720319071 Display Question Number : Yes Is Question

Mandatory : No

Root Mean Square value of $\sqrt{9 - 2x^2}$ over the range $x = 0$ to $x = 3$ is

Options :

1. ✔ $\sqrt{3}$

2. ✘ 3

3. ✘ $\sqrt{6}$

4. ✘ 9

Question Number : 44 Question Id : 47720319072 Display Question Number : Yes Is Question

Mandatory : No

The differential equation of the family of curves $y = Ae^{3x} + Be^{-2x}$, where A and B are arbitrary constants, is

Options :

1. ✘ $\frac{d^2y}{dx^2} - 5\frac{dy}{dx} + 6y = 0$

2. ✘ $\frac{d^2y}{dx^2} - \frac{dy}{dx} + 6y = 0$

3. ✘ $\frac{d^2y}{dx^2} + \frac{dy}{dx} - 6y = 0$

4. ✔ $\frac{d^2y}{dx^2} - \frac{dy}{dx} - 6y = 0$

Question Number : 45 Question Id : 47720319073 Display Question Number : Yes Is Question

Mandatory : No

The general solution of the differential equation $\frac{dy}{dx} = e^{x+y}$ is

Options :

1. ✘ $e^x + e^y = c$

2. ✘ $e^x - e^y = c$

3. ✓ $e^{x+y} + ce^y + 1 = 0$

4. ✗ $e^{x+y} = ce^y + 1$

Question Number : 46 Question Id : 47720319074 Display Question Number : Yes Is Question Mandatory : No

The general solution of the differential equation $\frac{dy}{dx} - \frac{3y}{x} = \frac{2y^2}{x^2}$ is

Options :

1. ✓ $y = cx^2(x + y)$

2. ✗ $\frac{y}{x - y} = cx^2$

3. ✗ $y = cx(x + y)$

4. ✗ $y = cx(x - y)$

Question Number : 47 Question Id : 47720319075 Display Question Number : Yes Is Question Mandatory : No

The general solution of the differential equation $\frac{dy}{dx} - \frac{2y}{x} = x^2 e^{2x}$ is

Options :

1. ✘ $2y = xe^{2x} + 2cx^2$

2. ✔ $2y = x^2e^{2x} + 2cx^2$

3. ✘ $y = 2x^2e^{2x} + cx^2$

4. ✘ $y = x^2e^{2x} + cx$

Question Number : 48 Question Id : 47720319076 Display Question Number : Yes Is Question

Mandatory : No

The general solution of the differential equation $\frac{dy}{dx} + y \cot x = y^3 \sin^2 x$ is

Options :

1. ✘ $2x^2y + \csc^2 x = cy$

2. ✘ $2xy^2 + \sin^2 x = cy^2$

3. ✔ $2xy^2 + \csc^2 x = cy^2$

4. ✘ $2xy + \csc^2 x = cy^2$

Question Number : 49 Question Id : 47720319077 Display Question Number : Yes Is Question

Mandatory : No

The particular integral of the differential equation $(D^2 - 3D + 2)y = e^{3x}$ is

Options :

1. ✘ $\frac{1}{20}e^{3x}$

2. ✘ $\frac{1}{16}e^{3x}$

3. ✘ $\frac{1}{3}e^{3x}$

4. ✔ $\frac{1}{2}e^{3x}$

Question Number : 50 Question Id : 47720319078 Display Question Number : Yes Is Question

Mandatory : No

The particular integral of the differential equation $(D^2 + 9)y = \sin 3x$ is

Options :

1. ✔ $-\frac{x \cos 3x}{6}$

2. ✘ $\frac{x \cos 3x}{6}$

3. ✘ $-\frac{x \sin 3x}{6}$

4. ✘

$$\frac{x \sin 3x}{6}$$

Physics

Section Id :	477203375
Section Number :	2
Mandatory or Optional :	Mandatory
Number of Questions :	25
Section Marks :	25
Enable Mark as Answered Mark for Review and Clear Response :	Yes

Question Number : 51 Question Id : 47720319079 Display Question Number : Yes Is Question

Mandatory : No

The dimension of Universal Gas Constant "R" is:

Options :

- ✘ $[M^2 L^2 T^{-2} K^{-1}]$
- ✘ $[M^1 L^2 T^{-2}]$
- ✔ $[M^1 L^2 T^{-2} K^{-1}]$
- ✘ $[M^2 L^2 T^{-2} K^0]$

Question Number : 52 Question Id : 47720319080 Display Question Number : Yes Is Question

Mandatory : No

The value of Planck's constant 'h' is $6.626 \times 10^{-34} \text{ J.Hz}^{-1}$. Its value in eV is

Options :

1. ✘ 1.054×10^{-34}
2. ✔ 4.135×10^{-15}
3. ✘ 0.241×10^{15}
4. ✘ Unchanged

Question Number : 53 Question Id : 47720319081 Display Question Number : Yes Is Question Mandatory : No

A unit vector perpendicular to $A = \hat{i} + \hat{j} - \hat{k}$ and $B = 2\hat{i} - \hat{j} + 3\hat{k}$ is

Options :

1. ✘ $\hat{n} = (2\hat{i} - \hat{j} - 3\hat{k}) / \sqrt{14}$
2. ✔ $\hat{n} = (2\hat{i} - 5\hat{j} - 3\hat{k}) / \sqrt{38}$
3. ✘ $\hat{n} = (2\hat{i} - 5\hat{j} - 3\hat{k}) / \sqrt{28}$
4. ✘ $\hat{n} = (\hat{i} - \hat{j} - \hat{k}) / \sqrt{3}$

Question Number : 54 Question Id : 47720319082 Display Question Number : Yes Is Question Mandatory : No

If the two vectors **A** and **B** are such that $|\mathbf{A}-\mathbf{B}| = |\mathbf{A}+\mathbf{B}|$ then

Options :

1. ✘ $\mathbf{A} = \mathbf{B}$

2. ✘ A is parallel to B

3. ✘ $|\mathbf{B}| = 0$

4. ✔ A is perpendicular to B

Question Number : 55 Question Id : 47720319083 Display Question Number : Yes Is Question

Mandatory : No

A rubber ball of mass 0.2 kg falls onto the floor. The ball hits with a speed of 8 m/s and rebounds with approximately the same speed. High speed photographs show that the ball is in contact with the floor for 10^{-3} s. Then the average force exerted on the ball by the floor is

Options :

1. ✘ 1,600 N

2. ✘ 0 N

3. ✔ 3,200 N

4. ✘ 320 N

Question Number : 56 Question Id : 47720319084 Display Question Number : Yes Is Question

Mandatory : No

A projectile is fired with a speed 'u' at an angle θ with the horizontal. Find its speed when its direction of motion makes an angle α with the horizontal.

Options :

1. ✘ $u \cos(\theta) \cos(\alpha)$

2. ✘ $u \cos(\theta)$

3. ✘ $u \cos(\alpha)$

4. ✔ $u \cos(\theta) \sec(\alpha)$

Question Number : 57 Question Id : 47720319085 Display Question Number : Yes Is Question

Mandatory : No

A person travelling on a straight line moves with a uniform velocity ' v_1 ' for a distance ' x ' and with a uniform velocity ' v_2 ' for the next equal distance. The average velocity ' v ' is given by

Options :

1. ✘ $v = \frac{v_1 + v_2}{2}$

2. ✘ $v = \sqrt{v_1 v_2}$

3. ✔ $\frac{2}{v} = \frac{1}{v_1} + \frac{1}{v_2}$

4. ✘ $\frac{1}{v} = \frac{1}{v_1} + \frac{1}{v_2}$

Question Number : 58 Question Id : 47720319086 Display Question Number : Yes Is Question

Mandatory : No

A ball is dropped from a height ' H '. If it takes 0.2 sec to cross the last 6.0 m before hitting the ground, the value of height ' H ' from which it was dropped is

Options :

1. ✔ 48 m

2. ✘ 42 m

3. ✘ 12 m

4. ✘ 30 m

Question Number : 59 Question Id : 47720319087 Display Question Number : Yes Is Question

Mandatory : No

Mark the correct statement about the frictional force 'f' when a body slides across a surface with coefficient of friction μ .

Options :

1. ✘ The magnitude of 'f' is less than μN

2. ✔ 'f' is independent of the area of contact

3. ✘ 'f' depends on the area of contact

4. ✘ 'f' is directly proportional to the instantaneous velocity of the body

Question Number : 60 Question Id : 47720319088 Display Question Number : Yes Is Question

Mandatory : No

A body starts slipping down an incline and moves half meter in half second. How long will it take to move the next half meter?

Options :

1. ✔ 0.2 sec

2. ✘ 0.5 sec

3. ✘ 1.0 sec

4. ✘ 0.1 sec

Question Number : 61 Question Id : 47720319089 Display Question Number : Yes Is Question

Mandatory : No

The energy needed to eject a 50kg spacecraft from the surface of the earth is (radius of the earth is 6.4×10^6 m)

Options :

1. ✘ 1.1×10^4 J

2. ✘ 1.1×10^9 J

3. ✘ 3.13×10^4 J

4. ✔ 3.13×10^9 J

Question Number : 62 Question Id : 47720319090 Display Question Number : Yes Is Question

Mandatory : No

A particle of mass 'm' moves in one dimension along the positive x-axis. It is acted on by a constant force directed towards the origin with magnitude 'B', and an inverse square law repulsive force with magnitude (A/x^2) away from the origin. The equilibrium position x_0 of the mass is at

Options :

1. ✘ $x_0=0$

2. ✔ $x_0=(A/B)^{1/2}$

3. ✘ $x_0 = (A/B)$

4. ✘ $x_0 = (B/A)^{1/2}$

Question Number : 63 Question Id : 47720319091 Display Question Number : Yes Is Question Mandatory : No

Ocean thermal energy is due to

Options :

1. ✘ Energy stored by waves in the ocean

2. ✘ Tides arising out in the ocean

3. ✘ Pressure difference at different levels in the ocean

4. ✔ Temperature difference at different levels in the ocean

Question Number : 64 Question Id : 47720319092 Display Question Number : Yes Is Question Mandatory : No

Consider the wave $y = (10 \text{ mm}) \sin[(2 \text{ cm}^{-1})x - (60 \text{ s}^{-1})t]$. The time period of this wave is

Options :

1. ✔ $\frac{\pi}{30} \text{ sec}$

2. ✘ $\frac{30}{\pi} \text{ sec}$

3. ✘ $\frac{\pi}{60} \text{ sec}$

4. ✘ $\frac{\pi}{120}$ sec

Question Number : 65 Question Id : 47720319093 Display Question Number : Yes Is Question Mandatory : No

If the speed of sound at 0°C is 332ms^{-1} , then the atmospheric temperature of a day when sound travels 336 m in one second is

Options :

1. ✘ 4°C

2. ✘ 20°C

3. ✘ 17°C

4. ✔ 7°C

Question Number : 66 Question Id : 47720319094 Display Question Number : Yes Is Question Mandatory : No

A sound source vibrates with a frequency of 1.0 kHz. Two sound waves, originating from this source, travel along different paths in air, where one path is 166 cm longer than other and then meet at a point. Then what will be the nature of interference? The speed of sound in air is 332ms^{-1} .

Options :

1. ✔ It will be a constructive interference

2. ✘ It will be a destructive interference

3. ✘ Provided information is insufficient to say about nature of interference

4. ✘ It will depend on the type of source

Question Number : 67 Question Id : 47720319095 Display Question Number : Yes Is Question

Mandatory : No

A simple pendulum is taken to a place in space where its distance from the surface of the earth is equal to the radius of the earth. What will be the time period of small oscillations of the pendulum if the length of the string is 1.0 m. Take $g = \pi^2 \text{ m/s}^2$ at the surface of the earth.

Options :

1. ✘ 2 sec

2. ✔ 4 sec

3. ✘ $\frac{1}{\pi}$ sec

4. ✘ 2π sec

Question Number : 68 Question Id : 47720319096 Display Question Number : Yes Is Question

Mandatory : No

The motion of a block of mass 'm' is restricted on x-axis by attaching two identical springs of spring constant 'k' on its opposite sides. The other ends of the springs are fixed on walls. When the mass is displaced from its equilibrium position on either side, it executes a simple harmonic motion. The period of oscillations for this oscillation is

Options :

1. ✘ $2\pi\sqrt{\frac{m}{k}}$

2. ✘ $2\pi\sqrt{\frac{k}{m}}$

3. ✘ $2\pi\sqrt{\frac{2k}{m}}$

4. ✔ $2\pi\sqrt{\frac{m}{2k}}$

Question Number : 69 Question Id : 47720319097 Display Question Number : Yes Is Question

Mandatory : No

Is it always true that $dU = C_v dT$?

Options :

1. ✘ Yes.

2. ✘ No, it is never true

3. ✔ It is true only for ideal gas

4. ✘ It is true only for non-ideal gas

Question Number : 70 Question Id : 47720319098 Display Question Number : Yes Is Question

Mandatory : No

One mole of ideal monatomic gas is confined in a cylinder by a piston and is maintained at a constant temperature T_0 by thermal contact with a heat reservoir. The gas slowly expands from V_1 to V_2 while being held at the same temperature T_0 . The change in internal energy of the gas is

Options :

1. ✘ $RT_0 \ln(V_2/V_1)$

2. ✓ zero

3. ✗ RT_0

4. ✗ $RT_0 \ln(V_1/V_2)$

Question Number : 71 Question Id : 47720319099 Display Question Number : Yes Is Question Mandatory : No

A pan filled with hot food cools from 94°C to 86°C in 2 minutes when the room temperature is at 20°C . How long will it take to cool from 71°C to 69°C ?

Options :

1. ✓ 0.7 min

2. ✗ 0.5 min

3. ✗ 0.4 min

4. ✗ 2 min.

Question Number : 72 Question Id : 47720319100 Display Question Number : Yes Is Question Mandatory : No

In an adiabatic expansion of an ideal gas

Options :

1. ✗ $PV = \text{constant}$

2. ✗ $PV^{\gamma-1} = \text{constant}$

3. ✘ $TV^\gamma = \text{constant}$

4. ✔ $P^{1-\gamma}T^\gamma = \text{constant}$

Question Number : 73 Question Id : 47720319101 Display Question Number : Yes Is Question

Mandatory : No

The rms speed of a nitrogen (N_2) molecule at 300K is (One mole of N_2 has a mass of 28 g and $k_B = 1.38 \times 10^{-23} \text{ JK}^{-1}$)

Options :

1. ✘ 450 ms^{-1}

2. ✘ 123 ms^{-1}

3. ✔ 517 ms^{-1}

4. ✘ 230 ms^{-1}

Question Number : 74 Question Id : 47720319102 Display Question Number : Yes Is Question

Mandatory : No

Which of the following are not the properties of superconductors?

Options :

1. ✘ They possess infinite conductivity

2. ✘ They possess zero resistivity

3. ✔ They are ferromagnetic in nature

4. ✘ They are diamagnetic in nature

Question Number : 75 Question Id : 47720319103 Display Question Number : Yes Is Question

Mandatory : No

The minimum energy required for a photoelectron to escape from a metal plate in a photocell is called

Options :

1. ✘ Planck's constant

2. ✔ Work function

3. ✘ Threshold energy

4. ✘ Stopping voltage

Chemistry

Section Id :	477203376
Section Number :	3
Mandatory or Optional :	Mandatory
Number of Questions :	25
Section Marks :	25
Enable Mark as Answered Mark for Review and Clear Response :	Yes

Question Number : 76 Question Id : 47720319104 Display Question Number : Yes Is Question

Mandatory : No

Which of the following is not a fundamental particle?

Options :

1. ✘ Electron
2. ✘ Proton
3. ✔ Alpha particle
4. ✘ Neutron

Question Number : 77 Question Id : 47720319105 Display Question Number : Yes Is Question

Mandatory : No

A given orbital labelled by the magnetic quantum number, $m=-1$. This cannot be

Options :

1. ✔ s-orbital
2. ✘ p-orbital
3. ✘ d-orbital
4. ✘ f-orbital

Question Number : 78 Question Id : 47720319106 Display Question Number : Yes Is Question

Mandatory : No

Maximum number of electrons that may be present in one 4f-orbital is

Options :

1. ✓ 2

2. ✗ 4

3. ✗ 7

4. ✗ 14

Question Number : 79 Question Id : 47720319107 Display Question Number : Yes Is Question Mandatory : No

Which of the following is favourable condition for the formation of ionic bond?

Options :

1. ✗ Small cation with small charge

2. ✗ Small anion with large charge

3. ✓ Large difference in the electronegativity

4. ✗ Small cation with large charge

Question Number : 80 Question Id : 47720319108 Display Question Number : Yes Is Question Mandatory : No

The covalency of nitrogen in HNO_2 is

Options :

1. ✘ 0

2. ✘ 2

3. ✔ 3

4. ✘ 5

Question Number : 81 Question Id : 47720319109 Display Question Number : Yes Is Question Mandatory : No

The normality of 0.98%(w/v) H_2SO_4 solution is

Options :

1. ✘ 0.1N

2. ✔ 0.2N

3. ✘ 0.4N

4. ✘ 1 N

Question Number : 82 Question Id : 47720319110 Display Question Number : Yes Is Question Mandatory : No

The equivalent weight of CuSO_4 when it is converted to Cu_2I_2 (M= Mol.wt)

Options :

1. ✔

M/1

2. ✘ M/2

3. ✘ M/3

4. ✘ 2M

Question Number : 83 Question Id : 47720319111 Display Question Number : Yes Is Question Mandatory : No

Which of the following is centi-normal solution ?

Options :

1. ✘ 1 N

2. ✘ N/10

3. ✘ N/20

4. ✔ N/100

Question Number : 84 Question Id : 47720319112 Display Question Number : Yes Is Question Mandatory : No

The unit for ionic product of water is

Options :

1. ✘ Mole/kg

2. ✘ Mole-kg

3. ✔ Mole²lit⁻²

4. ✘ Mole²lit²

Question Number : 85 Question Id : 47720319113 Display Question Number : Yes Is Question Mandatory : No

Which of the following is relatively strong Lewis acid?

Options :

1. ✘ BF₃

2. ✘ BCl₃

3. ✘ BBr₃

4. ✔ BI₃

Question Number : 86 Question Id : 47720319114 Display Question Number : Yes Is Question Mandatory : No

The decrease in electrical conductivity of metals with increase in temperature is due to increase in

Options :

1. ✘ the velocity of electrons

2. ✓ the resistance of the metal

3. ✘ the number of electrons

4. ✘ the number of metal atoms

Question Number : 87 Question Id : 47720319115 Display Question Number : Yes Is Question Mandatory : No

In the electrolytic cell, flow of electrons is from:

Options :

1. ✘ Cathode to anode in the solution

2. ✘ Cathode to anode through external circuit

3. ✓ Anode to cathode through external circuit

4. ✘ Anode to cathode in the solution

Question Number : 88 Question Id : 47720319116 Display Question Number : Yes Is Question Mandatory : No

The product of electrolysis of aqueous NaCl solution are

Options :

1. ✘ Na at cathode and Cl_2 at anode

2. ✓ H_2 at cathode and Cl_2 at anode
3. ✗ H_2 at cathode and O_2 at anode
4. ✗ Na at cathode and O_2 at anode

Question Number : 89 Question Id : 47720319117 Display Question Number : Yes Is Question Mandatory : No

When zinc piece is kept in CuSO_4 solution, copper get precipitated because

Options :

1. ✗ Standard reduction potential of zinc is more than copper
2. ✓ Standard reduction potential of zinc is less than copper
3. ✗ Atomic number of zinc is larger than copper
4. ✗ Atomic number of zinc is lower than copper

Question Number : 90 Question Id : 47720319118 Display Question Number : Yes Is Question Mandatory : No

Hardness of water is expressed in terms of ----- equivalents.

Options :

1. ✓ CaCO_3

2. ✘ MgCO_3

3. ✘ Na_2CO_3

4. ✘ K_2CO_3

Question Number : 91 Question Id : 47720319119 Display Question Number : Yes Is Question Mandatory : No

Anion exchange resin is regenerated by using

Options :

1. ✘ dil NaCl

2. ✘ dil HCl

3. ✔ dil NaOH

4. ✘ dil KCl

Question Number : 92 Question Id : 47720319120 Display Question Number : Yes Is Question Mandatory : No

Which of the following is responsible for temporary hardness?

Options :

1. ✘ MgCl_2

2. ✘ CaSO_4

3. ✘ MgSO_4

4. ✔ $\text{Mg}(\text{HCO}_3)_2$

Question Number : 93 Question Id : 47720319121 Display Question Number : Yes Is Question Mandatory : No

Corrosion is an example of -----

Options :

1. ✔ Oxidation

2. ✘ Reduction

3. ✘ Electrolysis

4. ✘ Hydrolysis

Question Number : 94 Question Id : 47720319122 Display Question Number : Yes Is Question Mandatory : No

In electrochemical corrosion, if the formed corrosion product is insoluble in the medium then the corrosion rate further -----

Options :

1. ✘ Increases

2. ✔ Decreases

3. ✘ Partially increases

4. ✘ No change

Question Number : 95 Question Id : 47720319123 Display Question Number : Yes Is Question Mandatory : No

Which of the following is an example of co-polymer ?

Options :

1. ✘ PVC

2. ✘ Teflon

3. ✘ Polythene

4. ✔ Buna-S rubber

Question Number : 96 Question Id : 47720319124 Display Question Number : Yes Is Question Mandatory : No

Which of the following polymer contains nitrogen atoms ?

Options :

1. ✘ PVC

2. ✘ Bakelite

3. ✔ Nylon

4. ✘ Teflon

Question Number : 97 Question Id : 47720319125 Display Question Number : Yes Is Question Mandatory : No

Isoprene is monomer of

Options :

1. ✘ Teflon

2. ✘ Nylon

3. ✔ Natural rubber

4. ✘ PVC

Question Number : 98 Question Id : 47720319126 Display Question Number : Yes Is Question Mandatory : No

The only liquid fuel in nature is

Options :

1. ✘ Kerosene

2. ✘ Diesel

3. ✘ Petrol

4. ✔ Petroleum

Question Number : 99 Question Id : 47720319127 Display Question Number : Yes Is Question

Mandatory : No

The medium which reacts with pollutant is called

Options :

1. ✓ Sink
2. ✗ Receptor
3. ✗ Speciation
4. ✗ Contaminant

Question Number : 100 Question Id : 47720319128 Display Question Number : Yes Is Question

Mandatory : No

Which of the following is used in the estimation of Chemical Oxygen Demand (COD) ?

Options :

1. ✗ Methyl orange
2. ✓ $K_2Cr_2O_7 + 50\% H_2SO_4$
3. ✗ $CaOCl_2 + 50\% H_2SO_4$
4. ✗ Alum +CaO

Electrical and Electronics Engineering

Section Id :	477203377
Section Number :	4
Mandatory or Optional :	Mandatory
Number of Questions :	100
Section Marks :	100
Enable Mark as Answered Mark for Review and Clear Response :	Yes

Question Number : 101 Question Id : 47720319129 Display Question Number : Yes Is Question Mandatory : No

The demagnetizing component of armature reaction in a DC generator

Options :

1. ✓ Reduces generated emf
2. ✗ Increases armature speed
3. ✗ Reduces interpoles flux density
4. ✗ Results in sparking trouble

Question Number : 102 Question Id : 47720319130 Display Question Number : Yes Is Question Mandatory : No

A 4 pole, lap wound d.c. generator has 40 coils with 8 turns per coil. It is driven at 1200 rpm. If the flux per pole is 0.022 Wb, then the generated emf is

Options :

1. ✗ 265.8 V

2. ✘ 276.3 V

3. ✔ 281.6 V

4. ✘ 287.9 V

Question Number : 103 Question Id : 47720319131 Display Question Number : Yes Is Question Mandatory : No

In Fleming's right hand rule, the direction of the induced emf in the conductor is given by

Options :

1. ✘ Index finger

2. ✔ Middle finger

3. ✘ Thumb

4. ✘ Ring finger

Question Number : 104 Question Id : 47720319132 Display Question Number : Yes Is Question Mandatory : No

The armature reaction effect in d.c. machines can be neutralized by using

Options :

1. ✘ Only compensating winding

2. ✘ Only interpoles

3. ✓ Both compensating winding and interpoles

4. ✗ Main field winding

Question Number : 105 Question Id : 47720319133 Display Question Number : Yes Is Question Mandatory : No

Which of the following motor is having very high no load speed?

Options :

1. ✗ DC shunt motor

2. ✓ DC series motor

3. ✗ DC compound motor

4. ✗ Induction motor

Question Number : 106 Question Id : 47720319134 Display Question Number : Yes Is Question Mandatory : No

If a shunt motor is started with its field winding open then

Options :

1. ✗ It will rotate at the same speed as that with its field winding closed

2. ✗ It will rotate at less speed as that with its field winding closed

3. ✓ It will rotate at dangerously high speed

4. ✘ It will not rotate

Question Number : 107 Question Id : 47720319135 Display Question Number : Yes Is Question Mandatory : No

If a resistance is added in series with the field winding of d.c. shunt motor, then its

Options :

1. ✘ Both speed and torque decreases
2. ✘ Both speed and torque increases
3. ✘ Speed decreases, torque increases
4. ✔ Speed increases, torque decreases

Question Number : 108 Question Id : 47720319136 Display Question Number : Yes Is Question Mandatory : No

A 220 V, d.c. motor draws an armature current of 20 A. Its armature resistance is 0.6 ohm. Then the back emf in the motor will be

Options :

1. ✘ 195 V
2. ✘ 202 V
3. ✔ 208 V

4. ✘ 215 V

Question Number : 109 Question Id : 47720319137 Display Question Number : Yes Is Question Mandatory : No

The main purpose of performing short circuit test on a transformer is to measure its

Options :

1. ✔ Copper loss

2. ✘ Core loss

3. ✘ Insulation resistance

4. ✘ Total loss

Question Number : 110 Question Id : 47720319138 Display Question Number : Yes Is Question Mandatory : No

The essential condition for parallel operation of two single-phase transformers is that they should have the same

Options :

1. ✘ KVA Rating

2. ✘ Turn Ratio

3. ✘ Size

4. ✔

Polarity and Turn Ratio

Question Number : 111 Question Id : 47720319139 Display Question Number : Yes Is Question

Mandatory : No

Which of the following loss in a transformer is zero even at full load?

Options :

1. ✘ Eddy current loss
2. ✘ Core loss
3. ✘ Copper loss
4. ✔ Friction loss

Question Number : 112 Question Id : 47720319140 Display Question Number : Yes Is Question

Mandatory : No

The size of the transformer core mainly depends on

Options :

1. ✘ Air gap
2. ✘ Area of core
3. ✘ Flux density of core
4. ✔ Frequency and area of core

Question Number : 113 Question Id : 47720319141 Display Question Number : Yes Is Question

Mandatory : No

Open delta transformers can be obtained from _____

Options :

1. ✓ Delta-delta
2. ✗ Star-delta
3. ✗ Delta-star
4. ✗ Only Star

Question Number : 114 Question Id : 47720319142 Display Question Number : Yes Is Question

Mandatory : No

What are the modes in which power can be transferred in an autotransformer?

Options :

1. ✗ Conduction and intension
2. ✗ Induction and intension
3. ✓ Conduction and Induction
4. ✗ Cannot be said

Question Number : 115 Question Id : 47720319143 Display Question Number : Yes Is Question

Mandatory : No

In a transformer the resistance between its primary and secondary is

Options :

1. ✘ Zero
2. ✔ Infinite
3. ✘ 1000 ohm
4. ✘ 100 ohm

Question Number : 116 Question Id : 47720319144 Display Question Number : Yes Is Question Mandatory : No

Alternator on infinite bus bar has constant _____

Options :

1. ✔ Terminal voltage and frequency
2. ✘ Frequency
3. ✘ Power factor
4. ✘ Power factor and terminal voltage

Question Number : 117 Question Id : 47720319145 Display Question Number : Yes Is Question Mandatory : No

The rating of the alternator is decided by _____

Options :

1. ✔

Losses

2. ✘ Voltage
3. ✘ Armature Current
4. ✘ Temperature

Question Number : 118 Question Id : 47720319146 Display Question Number : Yes Is Question

Mandatory : No

The short circuit characteristic of alternator is a straight line due to _____

Options :

1. ✔ No saturation
2. ✘ No armature reaction
3. ✘ No eddy current
4. ✘ No hysteresis loss

Question Number : 119 Question Id : 47720319147 Display Question Number : Yes Is Question

Mandatory : No

What happens if field winding of the synchronous motor is short circuited?

Options :

1. ✘ First, it starts as induction motor then run as synchronous motor

2. ✘ It will not start
3. ✘ Motor will burn out
4. ✔ It runs as induction motor

Question Number : 120 Question Id : 47720319148 Display Question Number : Yes Is Question Mandatory : No

The armature current of the synchronous motor has large values for

Options :

1. ✘ High excitation
2. ✘ Unity power factor
3. ✔ Both high and low excitation
4. ✘ Only at low excitation

Question Number : 121 Question Id : 47720319149 Display Question Number : Yes Is Question Mandatory : No

The damper winding in a synchronous motor is provided for

Options :

1. ✘ Starting torque only
2. ✘ Reducing eddy currents

3. ✓ Preventing hunting and providing the starting torque

4. ✗ Reducing the noise level

Question Number : 122 Question Id : 47720319150 Display Question Number : Yes Is Question Mandatory : No

If autotransformer method of starting is used to start an induction motor to replace star-delta method, then the required tapping on the transformer will be _____

Options :

1. ✓ 57.73%

2. ✗ 86.7%

3. ✗ 57%

4. ✗ 66.66%

Question Number : 123 Question Id : 47720319151 Display Question Number : Yes Is Question Mandatory : No

Three phase supply is fed to the Induction motor and is running at its normal operating conditions. Then the synchronous speed can be defined as speed at which?

Options :

1. ✓ Stator magnetic field rotates

2. ✗ Rotor magnetic field rotates

3. ✘ Rotor rotates

4. ✘ Slip speed

Question Number : 124 Question Id : 47720319152 Display Question Number : Yes Is Question Mandatory : No

A 4 pole three phase induction motor having synchronous speed of 1500 rpm is operating at 1450rpm. The frequency of the induced emf in rotor is?

Options :

1. ✔ 1.667 Hz

2. ✘ 16.667 Hz

3. ✘ 0.1667 Hz

4. ✘ 166.667 Hz

Question Number : 125 Question Id : 47720319153 Display Question Number : Yes Is Question Mandatory : No

In a 3-phase slip ring induction motor high starting torque is achieved by

Options :

1. ✘ Increasing supply voltage

2. ✘ Increasing supply frequency

3. ✘ Connecting a capacitor across the motor terminals

4. ✓ Connecting a star connected resistance across slip ring terminals of motor

Question Number : 126 Question Id : 47720319154 Display Question Number : Yes Is Question

Mandatory : No

In a capacitor start and run motors the function of the running capacitor in series with the auxiliary winding is to

Options :

1. ✓ Improve power factor
2. ✗ Reduce fluctuations in torque
3. ✗ Increase overload capacity
4. ✗ To improve torque

Question Number : 127 Question Id : 47720319155 Display Question Number : Yes Is Question

Mandatory : No

In split-phase motor, the main winding is made up of

Options :

1. ✗ Thick wire placed at the top of the slots
2. ✓ Thick wire placed at the bottom of the slots
3. ✗ Thin wire placed at the top of the slots
4. ✗ Thin wire placed at the bottom of the slots

Question Number : 128 Question Id : 47720319156 Display Question Number : Yes Is Question

Mandatory : No

The power factor of a single phase load can be calculated if the instruments available are

Options :

1. ✘ One voltmeter and one ammeter
2. ✔ One voltmeter, one ammeter and one wattmeter
3. ✘ One voltmeter, one ammeter and one energy meter
4. ✘ Only wattmeter

Question Number : 129 Question Id : 47720319157 Display Question Number : Yes Is Question

Mandatory : No

In a single phase power factor meter the phase difference between the currents in the two pressure coils is

Options :

1. ✘ Exactly 0°
2. ✘ Approximately 0°
3. ✔ Exactly 90°
4. ✘ Approximately 90°

Question Number : 130 Question Id : 47720319158 Display Question Number : Yes Is Question Mandatory : No

The disc of an instrument using eddy current damping should be made of

Options :

1. ✘ Conducting and magnetic material
2. ✘ Non-conducting and magnetic material
3. ✔ Conducting and nonmagnetic material
4. ✘ Only conducting material

Question Number : 131 Question Id : 47720319159 Display Question Number : Yes Is Question Mandatory : No

If damping torque is not provided in an instrument

Options :

1. ✘ An instrument will show full wave of quantity even under small values
2. ✘ The pointer will move only when full rated load is provided
3. ✘ The pointer will oscillate about its final deflected position and will never come to rest even under steady conditions
4. ✔ The pointer will oscillate about its final deflected position for quite some time before coming to rest

Question Number : 132 Question Id : 47720319160 Display Question Number : Yes Is Question

Mandatory : No

What should be the height of the 'Roof Pole'?

Options :

1. ✘ 3m
2. ✔ Less than 3m
3. ✘ More than 3m
4. ✘ Cannot be decided

Question Number : 133 Question Id : 47720319161 Display Question Number : Yes Is Question

Mandatory : No

Earthing is necessary to give protection against

Options :

1. ✔ Danger of electric shock
2. ✘ Voltage fluctuation
3. ✘ Overloading
4. ✘ High temperature of the conductors

Question Number : 134 Question Id : 47720319162 Display Question Number : Yes Is Question

Mandatory : No

The earthing rod orientation in the pit should be:

Options :

1. ✘ 45°
2. ✘ Horizontal
3. ✔ Vertical
4. ✘ 75°

Question Number : 135 Question Id : 47720319163 Display Question Number : Yes Is Question Mandatory : No

What is the cause for mechanical overloads in the induction motors?

Options :

1. ✔ Stalling
2. ✘ Blowing of fuse
3. ✘ Under voltage
4. ✘ Open circuit

Question Number : 136 Question Id : 47720319164 Display Question Number : Yes Is Question Mandatory : No

Locomotives with monometer bogies have

Options :

1. ✘ Uneven distribution of tractive effect

2. ✓ Suitability for passenger as well freight service
3. ✘ Lot of skidding
4. ✘ Low coefficient of adhesion

Question Number : 137 Question Id : 47720319165 Display Question Number : Yes Is Question Mandatory : No

Specific energy consumption is least in _____ service.

Options :

1. ✓ Main line
2. ✘ Urban
3. ✘ Suburban
4. ✘ Rural service only

Question Number : 138 Question Id : 47720319166 Display Question Number : Yes Is Question Mandatory : No

The coasting retardation is around

Options :

1. ✘ 16 km phps
2. ✘ 1.6 km phps

3. ✓ 0.16 km phps

4. ✗ 40 km phps

Question Number : 139 Question Id : 47720319167 Display Question Number : Yes Is Question Mandatory : No

Overhead lines for power supply to tram cars are at a minimum height of

Options :

1. ✗ 3 m

2. ✗ 6 m

3. ✓ 10 m

4. ✗ 15 m

Question Number : 140 Question Id : 47720319168 Display Question Number : Yes Is Question Mandatory : No

The rate of acceleration on suburban or urban services is restricted by the consideration of

Options :

1. ✗ Engine power

2. ✗ Track curves

3. ✓ Passenger discomfort

4. ✘ Track size

Question Number : 141 Question Id : 47720319169 Display Question Number : Yes Is Question Mandatory : No

Which of the following is the advantage of electric braking?

Options :

1. ✘ It is instantaneous
2. ✘ Motor continues to remain loaded during braking
3. ✔ It avoids wear of track
4. ✘ More heat is generated during braking

Question Number : 142 Question Id : 47720319170 Display Question Number : Yes Is Question Mandatory : No

The value of coefficient of adhesion will be high when rails are

Options :

1. ✘ Greased
2. ✔ Cleaned with sand
3. ✘ Sprayed with oil
4. ✘ Wet

Question Number : 143 Question Id : 47720319171 Display Question Number : Yes Is Question

Mandatory : No

Which of the following is the disadvantage of electric traction over other systems of traction?

Options :

1. ✘ Corrosion problems in the underground pipe work
2. ✘ Short time power failure interrupts traffic for hours
3. ✔ High Capital outlay in fixed installations beside route limitation
4. ✘ Interference with communication lines

Question Number : 144 Question Id : 47720319172 Display Question Number : Yes Is Question

Mandatory : No

With regards to measuring current and voltage in an AC circuit, modern AC instruments are calibrated to read:

Options :

1. ✔ RMS values
2. ✘ Peak values
3. ✘ Average values
4. ✘ Form factor values

Question Number : 145 Question Id : 47720319173 Display Question Number : Yes Is Question

Mandatory : No

The current waveform for a purely resistive circuit:

Options :

1. ✘ Leads the voltage by 90°
2. ✔ Is in phase with the voltage
3. ✘ Lags the voltage by 90°
4. ✘ Alternately leads and lags the voltage

Question Number : 146 Question Id : 47720319174 Display Question Number : Yes Is Question

Mandatory : No

When two capacitors are connected in series, the total capacitance:

Options :

1. ✘ Is double the capacitance of any one
2. ✔ Is decreased
3. ✘ Is increased
4. ✘ Remains the same as the largest one

Question Number : 147 Question Id : 47720319175 Display Question Number : Yes Is Question

Mandatory : No

The power factor of an AC circuit can be found using the formula, Power factor =

Options :

1. ✘ Volt-amperes/watts
2. ✘ Volt-amperes x current
3. ✔ Watts/volt-amperes
4. ✘ Volts x volt-amperes

Question Number : 148 Question Id : 47720319176 Display Question Number : Yes Is Question Mandatory : No

The reactive power can be measured with wattmeter when voltage across voltage coil is adjusted to be out of phase with the current by

Options :

1. ✔ 90°
2. ✘ 180°
3. ✘ 45°
4. ✘ 0°

Question Number : 149 Question Id : 47720319177 Display Question Number : Yes Is Question Mandatory : No

The 8051 microcontroller is of ___ pin package as a _____ processor.

Options :

1. ✘ 30, 1byte

2. ✘ 20, 1 byte

3. ✔ 40, 8 bit

4. ✘ 40, 8 byte

Question Number : 150 Question Id : 47720319178 Display Question Number : Yes Is Question

Mandatory : No

What is the address range of SFR Register bank?

Options :

1. ✘ 00H-77H

2. ✘ 40H-80H

3. ✘ 80H-7FH

4. ✔ 80H-FFH

Question Number : 151 Question Id : 47720319179 Display Question Number : Yes Is Question

Mandatory : No

Serial port interrupt is generated, if _____ bits are set

Options :

1. ✘ IE

2. ✘ RI, IE

3. ✘ IP, TI

4. ✔ RI, TI

Question Number : 152 Question Id : 47720319180 Display Question Number : Yes Is Question Mandatory : No

In 8051 which interrupt has highest priority?

Options :

1. ✘ IE1

2. ✘ TF0

3. ✔ IE0

4. ✘ TF1

Question Number : 153 Question Id : 47720319181 Display Question Number : Yes Is Question Mandatory : No

The condition for the validity of Ohm's law is that the

Options :

1. ✔ Temperature should remain constant

2. ✘ Current should be proportional to voltage

3. ✘ Resistance must be wire wound type

4. ✘ Resistance must be varying type

Question Number : 154 Question Id : 47720319182 Display Question Number : Yes Is Question Mandatory : No

Property of a material which opposes the production of magnetic flux in it is called

Options :

1. ✘ MMF

2. ✔ Reluctance

3. ✘ Permeance

4. ✘ Permittivity

Question Number : 155 Question Id : 47720319183 Display Question Number : Yes Is Question Mandatory : No

Resistance of the conductor is doubled keeping the potential difference across it constant. The rate of generation of heat will be

Options :

1. ✔ Be halved

2. ✘ Becomes four times

3. ✘ Become one fourth

4. ✘ Be doubled

Question Number : 156 Question Id : 47720319184 Display Question Number : Yes Is Question

Mandatory : No

Which of the following statement is not correct about the magnetic field?

Options :

1. ✘ Magnetic field lines form a continuous closed curve.
2. ✘ Magnetic field line do not intersect each other.
3. ✘ Direction of tangent at any point on the magnetic field line curve gives the direction of magnetic field at that point.
4. ✔ Outside the magnet, magnetic field lines go from South to North pole of the magnet.

Question Number : 157 Question Id : 47720319185 Display Question Number : Yes Is Question

Mandatory : No

What happens to the force acting between the charged particles, if the distance between them is halved?

Options :

1. ✔ It increases by four times
2. ✘ It gets doubled
3. ✘ It becomes half
4. ✘ It reduces by one-fourth

Question Number : 158 Question Id : 47720319186 Display Question Number : Yes Is Question

Mandatory : No

Which of the following is a semiconductor material?

Options :

1. ✘ Phosphorous
2. ✘ Rubber
3. ✔ Silicon
4. ✘ Aluminium

Question Number : 159 Question Id : 47720319187 Display Question Number : Yes Is Question

Mandatory : No

Which of the following circuit element is an active component?

Options :

1. ✘ Capacitor
2. ✔ Transistor
3. ✘ Inductor
4. ✘ Resistor

Question Number : 160 Question Id : 47720319188 Display Question Number : Yes Is Question

Mandatory : No

Which of the following generation station has minimum running cost?

Options :

1. ✘ Thermal power station
2. ✔ Hydro-electric power station
3. ✘ Nuclear power station
4. ✘ Gas based power station

Question Number : 161 Question Id : 47720319189 Display Question Number : Yes Is Question

Mandatory : No

Economiser is used to heat

Options :

1. ✘ Air
2. ✔ Feed water
3. ✘ Flue Gases
4. ✘ Smoke

Question Number : 162 Question Id : 47720319190 Display Question Number : Yes Is Question

Mandatory : No

Kaplan turbine is used for.....hydro-electric plant

Options :

1. ✘ Medium and low head
2. ✘ High head
3. ✔ Low head
4. ✘ Low and high head

Question Number : 163 Question Id : 47720319191 Display Question Number : Yes Is Question Mandatory : No

The function of a surge tank is.....

Options :

1. ✘ To supply water at constant pressure
2. ✘ To produce surges in the pipe line
3. ✔ To relieve water hammer pressures in the penstock pipe
4. ✘ To produce varying pressure

Question Number : 164 Question Id : 47720319192 Display Question Number : Yes Is Question Mandatory : No

When nuclear reactor is operating at constant power, the multiplication factor is.....

Options :

1. ✔ Equal to unity

2. ✘ More than unity

3. ✘ Less than unity

4. ✘ Zero

Question Number : 165 Question Id : 47720319193 Display Question Number : Yes Is Question Mandatory : No

The most appropriate operating speeds in rpm of generators used in Thermal, Nuclear and Hydro-power plants would respectively be

Options :

1. ✘ 3000, 300 and 1500

2. ✔ 3000, 3000 and 300

3. ✘ 1500, 1500 and 3000

4. ✘ 1000, 900 and 750

Question Number : 166 Question Id : 47720319194 Display Question Number : Yes Is Question Mandatory : No

To limit current chopping in vacuum circuit breakers, the contact material used has:

Options :

1. ✔ High vapour pressure and low conductivity properties

2. ✘ High vapour pressure and high conductivity properties
3. ✘ Low vapour pressure and high conductivity properties
4. ✘ Low vapour pressure and low conductivity properties

Question Number : 167 Question Id : 47720319195 Display Question Number : Yes Is Question Mandatory : No

A Mho relay is a:

Options :

1. ✔ Voltage restrained directional relay
2. ✘ Voltage controlled over current relay
3. ✘ Directional restrained over current relay
4. ✘ Directional restrained over voltage relay

Question Number : 168 Question Id : 47720319196 Display Question Number : Yes Is Question Mandatory : No

The normal practice to specify the making current of a circuit breaker is in terms of

Options :

1. ✘ R.M.S value
2. ✔ Peak value

3. ✘ Average value

4. ✘ Form factor

Question Number : 169 Question Id : 47720319197 Display Question Number : Yes Is Question

Mandatory : No

Auto reclosing is used in case of

Options :

1. ✘ Lightning arrester

2. ✔ Air blast Circuit Breaker

3. ✘ Bulk oil Circuit Breaker

4. ✘ Minimum oil Circuit Breaker

Question Number : 170 Question Id : 47720319198 Display Question Number : Yes Is Question

Mandatory : No

Ring main distribution is preferred to a radial system because

Options :

1. ✔ Voltage drop in the feeder is less and supply is more reliable

2. ✘ Voltage drop in the feeder is less and power factor is high

3. ✘ Power factor is high and supply is more reliable

4. ✘ Power factor is high and system is less expensive

Question Number : 171 Question Id : 47720319199 Display Question Number : Yes Is Question Mandatory : No

The good effect of corona on overhead lines is to

Options :

Increase the line carrying capacity due to conducting ionised air envelop

1. ✘ around the conductor

2. ✘ Increase the power factor due to corona loss

3. ✘ Reduce the radio interference from the conductor

4. ✔ Reduce the steepness of surge fronts.

Question Number : 172 Question Id : 47720319200 Display Question Number : Yes Is Question Mandatory : No

The values of A, B, C and D constants for a short transmission line are respectively

Options :

1. ✘ Z, 0, 1 and 1

2. ✘ 0, 1, 1 and 1

3. ✔ 1, Z, 0 and 1

4. ✘ 1, 1, Z and 0.

Question Number : 173 Question Id : 47720319201 Display Question Number : Yes Is Question

Mandatory : No

Between two supports, due to sag the conductor takes the form of

Options :

1. ✔ Catenary

2. ✘ Triangle

3. ✘ Ellipse

4. ✘ Semi-circle

Question Number : 174 Question Id : 47720319202 Display Question Number : Yes Is Question

Mandatory : No

Whenever the conductors are dead-ended or there is a change in the direction of transmission line, the insulators used are of the

Options :

1. ✘ Pin type

2. ✘ Suspension type

3. ✔ Strain type

4. ✘ Shackle type

Question Number : 175 Question Id : 47720319203 Display Question Number : Yes Is Question

Mandatory : No

Transmission lines are transposed to

Options :

1. ✘ Reduce copper loss
2. ✘ Reduce skin effect
3. ✔ Prevent interference with neighbouring telephone lines
4. ✘ prevent short-circuit between any two lines

Question Number : 176 Question Id : 47720319204 Display Question Number : Yes Is Question

Mandatory : No

The voltages across various discs of suspension insulators having identical discs is different due to

Options :

1. ✘ Surface leakage currents
2. ✘ Series capacitance
3. ✔ Shunt capacitances to ground
4. ✘ Series and shunt capacitances.

Question Number : 177 Question Id : 47720319205 Display Question Number : Yes Is Question

Mandatory : No

Sheaths are used in cables to:

Options :

1. ✘ Provide proper insulation
2. ✘ Provide mechanical strength
3. ✔ Prevent ingress of moisture
4. ✘ Prevent current

Question Number : 178 Question Id : 47720319206 Display Question Number : Yes Is Question

Mandatory : No

Stringing chart is useful for:

Options :

1. ✔ Finding the sag in the conductor
2. ✘ In the design of tower
3. ✘ In the design of insulator string
4. ✘ Finding the distance between the tower

Question Number : 179 Question Id : 47720319207 Display Question Number : Yes Is Question

Mandatory : No

Charging current in medium transmission line is

Options :

1. ✓ Maximum at receiving end
2. ✗ Maximum at sending end
3. ✗ More in between sending end and receiving end
4. ✗ Equal throughout the line

Question Number : 180 Question Id : 47720319208 Display Question Number : Yes Is Question

Mandatory : No

A PN junction acts as a

Options :

1. ✗ Controlled switch
2. ✗ Bidirectional switch
3. ✓ Unidirectional switch
4. ✗ Open circuit

Question Number : 181 Question Id : 47720319209 Display Question Number : Yes Is Question

Mandatory : No

Zener diode can be described as

Options :

1. ✘ A rectifier diode
2. ✔ A device with constant – voltage
3. ✘ A device with constant – current
4. ✘ A device that works in the forward region

Question Number : 182 Question Id : 47720319210 Display Question Number : Yes Is Question

Mandatory : No

A 4-variable AND-OR circuit produces a 1 at its Y output. Which combination of inputs is correct?

Options :

1. ✘ $A = 0, B = 0, C = 0, D = 0$
2. ✘ $A = 0, B = 1, C = 1, D = 0$
3. ✔ $A = 1, B = 1, C = 0, D = 0$
4. ✘ $A = 1, B = 0, C = 0, D = 0$

Question Number : 183 Question Id : 47720319211 Display Question Number : Yes Is Question

Mandatory : No

What type of logic circuit is represented by the figure shown below?

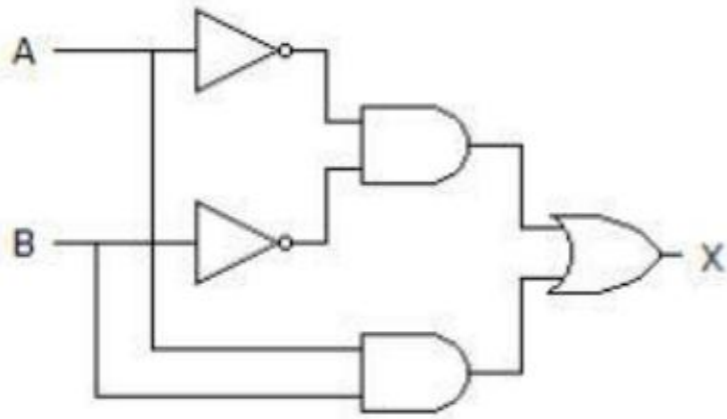

Options :

1. ✘ XOR
2. ✔ XNOR
3. ✘ XAND
4. ✘ XNAND

Question Number : 184 Question Id : 47720319212 Display Question Number : Yes Is Question

Mandatory : No

Which of the following expressions is in the sum-of-products form?

Options :

1. ✘ $(A + B)(C + D)$
2. ✘ $(AB)(CD)$
3. ✘ $AB(CD)$
4. ✔ $AB + CD$

Question Number : 185 Question Id : 47720319213 Display Question Number : Yes Is Question

Mandatory : No

What is the binary subtraction of $101001 - 010110 = ?$

Options :

1. ✓ 010011

2. ✗ 100110

3. ✗ 011001

4. ✗ 010010

Question Number : 186 Question Id : 47720319214 Display Question Number : Yes Is Question

Mandatory : No

Oscillators are used to _____ AC voltage.

Options :

1. ✗ Prevent

2. ✓ Generate

3. ✗ Amplify

4. ✗ Rectify

Question Number : 187 Question Id : 47720319215 Display Question Number : Yes Is Question

Mandatory : No

The output of oscillator will not depend upon _____

Options :

1. ✘ Feedback
2. ✘ Amplifier
3. ✘ Both feedback and amplifier
4. ✔ Input voltage

Question Number : 188 Question Id : 47720319216 Display Question Number : Yes Is Question Mandatory : No

The use of amplifier in a circuit is to _____ for input signal.

Options :

1. ✘ Provide a phase shift
2. ✔ Provide strength
3. ✘ Provide frequency enhancement
4. ✘ Make circuit compatible

Question Number : 189 Question Id : 47720319217 Display Question Number : Yes Is Question Mandatory : No

DC average current of a centre taped full wave rectifier is _____

(Where I_m is the maximum peak current of input)

Options :

1. ✔ $2I_m/\pi$

2. ✘ I_m/π

3. ✘ $I_m/2\pi$

4. ✘ $1.414I_m/\pi$

Question Number : 190 Question Id : 47720319218 Display Question Number : Yes Is Question Mandatory : No

For a NPN bipolar transistor, what is the main stream of current in the base region?

Options :

1. ✘ Drift of holes

2. ✔ Diffusion of holes

3. ✘ Drift of electrons

4. ✘ Diffusion of electrons

Question Number : 191 Question Id : 47720319219 Display Question Number : Yes Is Question Mandatory : No

A thyristor can be brought from the forward conduction mode to forward blocking mode by

Options :

1. ✘ The dv/dt triggering method

2. ✘ Applying a negative gate signal
3. ✘ Applying a positive gate signal
4. ✔ Applying a reverse voltage across anode-cathode terminals

Question Number : 192 Question Id : 47720319220 Display Question Number : Yes Is Question Mandatory : No

di/dt protection is provided to the thyristor by

Options :

1. ✘ Connecting an inductor in parallel across the load
2. ✔ Connecting an inductor in series with the load
3. ✘ Connecting an inductor in parallel across the gate terminal
4. ✘ Connecting an inductor in series with the gate

Question Number : 193 Question Id : 47720319221 Display Question Number : Yes Is Question Mandatory : No

SCRs are connected in parallel to fulfill the _____ demand

Options :

1. ✘ High voltage
2. ✔ High current
3. ✘

Size

4. ✘ Efficiency

Question Number : 194 Question Id : 47720319222 Display Question Number : Yes Is Question Mandatory : No

The GTO can be turned off

Options :

1. ✘ by a positive gate pulse
2. ✔ by a negative gate pulse
3. ✘ by a negative anode-cathode voltage
4. ✘ by removing the gate pulse

Question Number : 195 Question Id : 47720319223 Display Question Number : Yes Is Question Mandatory : No

A single phase full-converter using R load is a _____ quadrant converter and that using an RL load without FD is a _____ quadrant converter

Options :

1. ✘ One, one
2. ✘ Two, one
3. ✔ One, two

4. ✘ Two, two

Question Number : 196 Question Id : 47720319224 Display Question Number : Yes Is Question Mandatory : No

A chopper may be thought as a

Options :

1. ✘ An inverter with DC input
2. ✔ A DC equivalent of an AC transformer
3. ✘ A diode rectifier
4. ✘ A DC equivalent of an induction motor

Question Number : 197 Question Id : 47720319225 Display Question Number : Yes Is Question Mandatory : No

In case of the 120° mode of operation, _____ devices conduct at a time

Options :

1. ✔ 2
2. ✘ 3
3. ✘ 4
4. ✘ 6

Question Number : 198 Question Id : 47720319226 Display Question Number : Yes Is Question Mandatory : No

Which one of the following is the main advantage of the SMPS over linear power supply ?

Options :

1. ✘ No transformer is required
2. ✘ Only one stage of conversion
3. ✘ No filter is required
4. ✔ Low power dissipation

Question Number : 199 Question Id : 47720319227 Display Question Number : Yes Is Question Mandatory : No

_____ is used for critical loads where temporary power failure can cause a great deal of inconvenience

Options :

1. ✘ SMPS
2. ✔ UPS
3. ✘ MPS
4. ✘ RCCB

Question Number : 200 Question Id : 47720319228 Display Question Number : Yes Is Question

Mandatory : No

In order to prevent distortion in the output signal after amplification, the input signal must be

Options :

1. ✘ Be higher than the positive saturation level of the amplifier
2. ✘ Be lower than the negative saturation level of the amplifier
3. ✔ Lie with the negative and the positive saturation level of the amplifier
4. ✘ Be both higher than the positive saturation level of the amplifier and lower than the negative saturation level of the amplifier