

UGC NET PAPER 2 DECEMBER 3, 2021 SHIFT 2 ELECTRONIC SCIENCE QUESTION PAPER

Topic:- ElectSci_SHAAN_NOV21A

1) For semiconductor, with both electrons and holes as carriers, the resistivity can be expressed as:

[Question ID = 709][Question Description = S2_qSNz_PG_ETS_Q01]

1. $q(\mu_n n + \mu_p p)$

[Option ID = 2833]

2. $q(\mu_n n - \mu_p p)$

[Option ID = 2834]

3. $\frac{q}{(\mu_n n + \mu_p p)}$

[Option ID = 2835]

4. $\frac{1}{q(\mu_n n + \mu_p p)}$

[Option ID = 2836]

Correct Answer :-

• $q(\mu_n n + \mu_p p)$

[Option ID = 2833]

2) The band structure of a crystalline solid, that is, the energy momentum (E-K) relationship, is usually obtained by solving:

[Question ID = 710][Question Description = S2_qSNz_PG_ETS_Q02]

1. Laplace Equation [Option ID = 2837]

2. Poisson Equation [Option ID = 2838]

3. Schrodinger Equation [Option ID = 2839]

4. Maxwell Equation [Option ID = 2840]

Correct Answer :-

• Laplace Equation [Option ID = 2837]

3) The Schottky effect is the image force induced lowering of the potential energy for charge carrier emission when an electric field is applied. The attractive force called image force is:

[Question ID = 711][Question Description = S2_qSNz_PG_ETS_Q03]

1. $\frac{-q}{16\pi x^2}$

[Option ID = 2841]

2. $\frac{-q}{16\pi \epsilon_0 x}$

[Option ID = 2842]

3. $\frac{-q}{16\pi \epsilon_0 x^2}$

[Option ID = 2843]

4. $\frac{q}{8\pi \epsilon_0 x^2}$

[Option ID = 2844]

Correct Answer :-

• $\frac{-q}{16\pi x^2}$

[Option ID = 2841]

4) In JFET, the Pinch-off Voltage can be defined as:

[Question ID = 712][Question Description = S2_qSNz_PG_ETS_Q04]

1. $\frac{qN_D a^2}{\epsilon_s}$

[Option ID = 2845]

2. $\frac{qN_D a}{2\epsilon_s}$

[Option ID = 2846]

3. $\frac{qN_D a^2}{2 \epsilon_s}$

[Option ID = 2847]

4. $\frac{qN_D}{2 \epsilon_s \cdot a}$

[Option ID = 2848]

Correct Answer :-

• $\frac{qN_D a^2}{\epsilon_s}$

[Option ID = 2845]

5) The desired property of gate and interconnection metallization is [Question ID = 713][Question Description = S2_qSNz_PG_ETS_Q05]

1. High resistivity [Option ID = 2849]
2. Low resistivity [Option ID = 2850]
3. Low conductivity [Option ID = 2851]
4. Large stress [Option ID = 2852]

Correct Answer :-

- High resistivity [Option ID = 2849]

6) In a silicon oxidation model, $\frac{B}{A}$ is the linear rate constant and τ accounts for the shift in the time coordinate to account for the presence of the initial oxide layer, then the linear law is represented as:

[Question ID = 714][Question Description = S2_qSNz_PG_ETS_Q06]

1. $\frac{B}{A}(t - \tau)$

[Option ID = 2853]

2. $\frac{A}{B}(t - \tau)$

[Option ID = 2854]

3. $\frac{B}{A}(t + \tau)$

[Option ID = 2855]

4. $\frac{B t}{A \tau}$

[Option ID = 2856]

Correct Answer :-

• $\frac{B}{A}(t - \tau)$

[Option ID = 2853]

7) In a silicon oxidation model, if C_G and C_S are the oxidant concentration in the bulk of the gas and oxidant concentration adjacent to the oxide surface, respectively, then the gas phase flux are:

(h_G is the gas phase mass transfer coefficient)

[Question ID = 715][Question Description = S2_qSNz_PG_ETS_Q07]

1. $\frac{h_G}{C_G - C_S}$

[Option ID = 2857]

2. $\frac{h_G}{C_G + C_S}$

[Option ID = 2858]

3. $h_G(C_G - C_S)$

[Option ID = 2859]

4. $h_G(C_G + C_S)$

[Option ID = 2860]

Correct Answer :-

• $\frac{h_G}{C_G - C_S}$

[Option ID = 2857]

- 8) If C_s and C_l are the equilibrium concentration of impurities in the solid and liquid near the interface respectively, then for dilute solutions encountered in silicon growth, an equilibrium segregation coefficient K_a may be defined as:

[Question ID = 716][Question Description = S2_qSNz_PG_ETS_Q08]

1. $\frac{C_s}{C_l}$

[Option ID = 2861]

2. $\frac{C_l}{C_s}$

[Option ID = 2862]

3. $C_s - C_l$

[Option ID = 2863]

4. $\frac{C_s - C_l}{C_l}$

[Option ID = 2864]

Correct Answer :-

- $\frac{C_s}{C_l}$

[Option ID = 2861]

- 9) The circuit shown in the following figure is initially under steady-state condition. The switch is moved from position 1 to position 2 at $t = 0$. The current after switching will be:

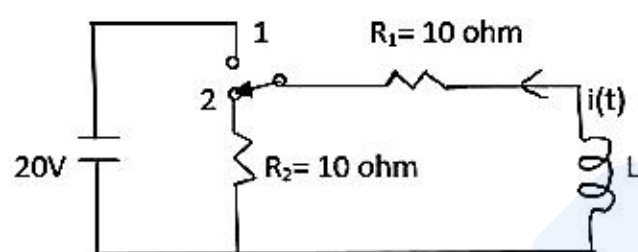

[Question ID = 717][Question Description = S2_qSNz_PG_ETS_Q09]

1. $2e^{-5t}$ A [Option ID = 2865]
2. $1 - 2e^{-5t}$ A [Option ID = 2866]
3. $1 + 2e^{-5t}$ A [Option ID = 2867]
4. $2e^{5t}$ A [Option ID = 2868]

Correct Answer :-

- $2e^{-5t}$ A [Option ID = 2865]

- 10) A differential equation is given as $x(t+2) + 3x(t+1) + 2x(t) = 0$; $x(0) = 0$, $x(1) = 1$. The solution of this equation will be:

[Question ID = 718][Question Description = S2_qSNz_PG_ETS_Q10]

1. $x(KT) = (-1)^k + (2)^k$ [Option ID = 2869]
2. $x(KT) = (-1)^k \cdot (2)^k$ [Option ID = 2870]
3. $x(KT) = (-1)^k + (-2)^k$ [Option ID = 2871]
4. $x(KT) = (-1)^k - (-2)^k$ [Option ID = 2872]

Correct Answer :-

- $x(KT) = (-1)^k + (2)^k$ [Option ID = 2869]

- 11) Consider the network shown in the following figure. The state equation of the system will be:

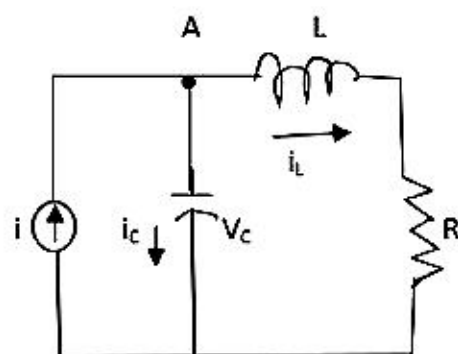

[Question ID = 719][Question Description = S2_qSNz_PG_ETS_Q11]

1. $\frac{d}{dt} \begin{bmatrix} V_c \\ i_L \end{bmatrix} = \begin{bmatrix} 0 & -1/C \\ 1/L & -R/L \end{bmatrix} \begin{bmatrix} V_c \\ i_L \end{bmatrix} + \begin{bmatrix} 1/C \\ 0 \end{bmatrix} i$

[Option ID = 2873]

$$2. \frac{d}{dt} \begin{bmatrix} v_C \\ i_L \end{bmatrix} = \begin{bmatrix} 0 & -R/L \\ 1/L & -1/C \end{bmatrix} \begin{bmatrix} v_C \\ i_L \end{bmatrix} + \begin{bmatrix} 1/C \\ 0 \end{bmatrix} i$$

[Option ID = 2874]

$$3. \frac{d}{dt} \begin{bmatrix} v_C \\ i_L \end{bmatrix} = \begin{bmatrix} 1/L & -R/L \\ 0 & -1/C \end{bmatrix} \begin{bmatrix} v_C \\ i_L \end{bmatrix} + \begin{bmatrix} 1/C \\ 0 \end{bmatrix} i$$

[Option ID = 2875]

$$4. \frac{d}{dt} \begin{bmatrix} v_C \\ i_L \end{bmatrix} = \begin{bmatrix} 1/L & R/L \\ 0 & -1/C \end{bmatrix} \begin{bmatrix} v_C \\ i_L \end{bmatrix} + \begin{bmatrix} 1/C \\ 0 \end{bmatrix} i$$

[Option ID = 2876]

Correct Answer :-

- $\frac{d}{dt} \begin{bmatrix} v_C \\ i_L \end{bmatrix} = \begin{bmatrix} 0 & -1/C \\ 1/L & -R/L \end{bmatrix} \begin{bmatrix} v_C \\ i_L \end{bmatrix} + \begin{bmatrix} 1/C \\ 0 \end{bmatrix} i$

[Option ID = 2873]

12) The roots of a system having a transfer function

$$G(s) = \frac{4(s+2)}{(s+3)(s+4)}$$

will be:

[Question ID = 720][Question Description = S2_qSNz_PG_ETS_Q12]

1. either -3 or -4 [Option ID = 2877]
2. either -3 or 4 [Option ID = 2878]
3. either 3 or -4 [Option ID = 2879]
4. either 3 or 4 [Option ID = 2880]

Correct Answer :-

- either -3 or -4 [Option ID = 2877]

13) An amplifier has power gain of 800. Its decibel power gain is:[Question ID = 721][Question Description = S2_qSNz_PG_ETS_Q13]

1. 19 dB [Option ID = 2881]
2. 30 dB [Option ID = 2882]
3. 28 dB [Option ID = 2883]
4. 29 dB [Option ID = 2884]

Correct Answer :-

- 19 dB [Option ID = 2881]

14) Which of the following statements is NOT correct about Bipolar Junction Transistors?[Question ID = 722][Question Description = S2_qSNz_PG_ETS_Q14]

1. Emitter-follower configuration will always have an output voltage slightly less than the input signal. [Option ID = 2885]
2. Common-base configuration has very low input impedance. [Option ID = 2886]
3. The CE emitter-bias configuration with an unbypassed emitter resistor has a larger input resistance than the bypassed configuration. [Option ID = 2887]
4. The voltage-divider bias configuration has much less stability than the fixed bias configuration. [Option ID = 2888]

Correct Answer :-

- Emitter-follower configuration will always have an output voltage slightly less than the input signal. [Option ID = 2885]

15) If A_{FT} is the total passband gain, f_L is low cutoff frequency, f_H is high cutoff frequency, then voltage gain magnitude of a band-pass filter is given by:

[Question ID = 723][Question Description = S2_qSNz_PG_ETS_Q15]

$$1. \left| \frac{V_0}{V_{in}} \right| = \frac{A_{FT}}{\sqrt{[1+(f/f_L)^2][1+(f/f_H)^2]}}$$

[Option ID = 2889]

$$2. \left| \frac{V_0}{V_{in}} \right| = \frac{A_{FT}(f/f_H)}{\sqrt{[1+(f/f_L)^2][1+(f/f_H)^2]}}$$

[Option ID = 2890]

$$3. \left| \frac{V_0}{V_{in}} \right| = \frac{A_{FT}(f/f_L)}{\sqrt{[1+(f/f_L)^2][1+(f/f_H)^2]}}$$

[Option ID = 2891]

$$4. \left| \frac{V_0}{V_{in}} \right| = \frac{A_{FT}(f/f_L)(f/f_H)}{\sqrt{[1+(f/f_L)^2][1+(f/f_H)^2]}}$$

[Option ID = 2892]

Correct Answer :-

- $\left| \frac{V_0}{V_{in}} \right| = \frac{A_{FT}}{\sqrt{[1+(f/f_L)^2][1+(f/f_H)^2]}}$

[Option ID = 2889]

16) Which of the following statements is wrong about noise in Operational Amplifiers?[Question ID = 724][Question Description = S2_qSNz_PG_ETS_Q16]

1. Thermal noise is the result of random motion of the charge carriers in a resistor. [Option ID = 2893]
2. Shot noise arises from the discrete nature of the current flow in electronic devices. [Option ID = 2894]
3. Popcorn noise is caused by imperfect semiconductor surface conditions. [Option ID = 2895]
4. Flicker noise occurs in active devices at very high frequencies. [Option ID = 2896]

Correct Answer :-

- Thermal noise is the result of random motion of the charge carriers in a resistor. [Option ID = 2893]

17) What is entered variable map?[Question ID = 725][Question Description = S2_qSNz_PG_ETS_Q17]

1. A map to solve the sequential circuits. [Option ID = 2897]
2. An alternative to Karnaugh Map where the variable is placed as output. [Option ID = 2898]
3. A modified version of Karnaugh Map where the variable is placed as composite. [Option ID = 2899]
4. A tabular method for logic simplification. [Option ID = 2900]

Correct Answer :-

- A map to solve the sequential circuits. [Option ID = 2897]

18) The simplified boolean expression for the following K-map to find F(A,B,C,D) in SOP:

AB \ CD	00	01	10	11
00	0	0	1	0
01	1	1	1	0
10	0	1	1	1
11	0	1	0	0

[Question ID = 726][Question Description = S2_qSNz_PG_ETS_Q18]

1. $BD + \bar{A}B\bar{D} + \bar{A}CD + AC\bar{D} + ABD$

[Option ID = 2901]

2. $BD + \bar{A}B\bar{D} + \bar{A}\bar{C}D + AC\bar{D}$

[Option ID = 2902]

3. $\bar{A}B\bar{D} + \bar{A}\bar{C}D + AC\bar{D} + ABD$

[Option ID = 2903]

4. $\bar{A}B\bar{C} + \bar{A}CD + AC\bar{D} + ABC$

[Option ID = 2904]

Correct Answer :-

- $BD + \bar{A}B\bar{D} + \bar{A}CD + AC\bar{D} + ABD$

[Option ID = 2901]

19) Determine the output of the logic array given in the following figure. The Xs represent connected link.

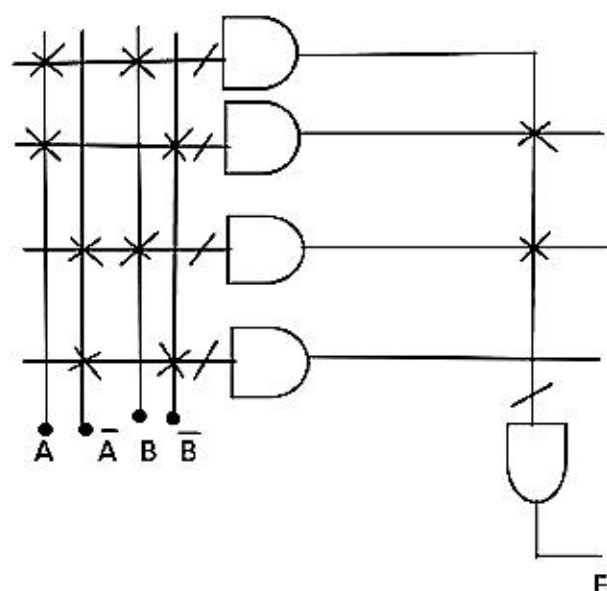

[Question ID = 727][Question Description = S2_qSNz_PG_ETS_Q19]

1. $\overline{A}\overline{B} + \overline{A}B$

[Option ID = 2905]

2. 1 [Option ID = 2906]

3. 0 [Option ID = 2907]

4. $AB + \overline{A}\overline{B}$

[Option ID = 2908]

Correct Answer :-

• $\overline{A}\overline{B} + \overline{A}B$

[Option ID = 2905]

20) The ripple counter shown in the following figure uses flip flops that trigger on the negative-edge transition of the C-P input. Is the counter self-starting?

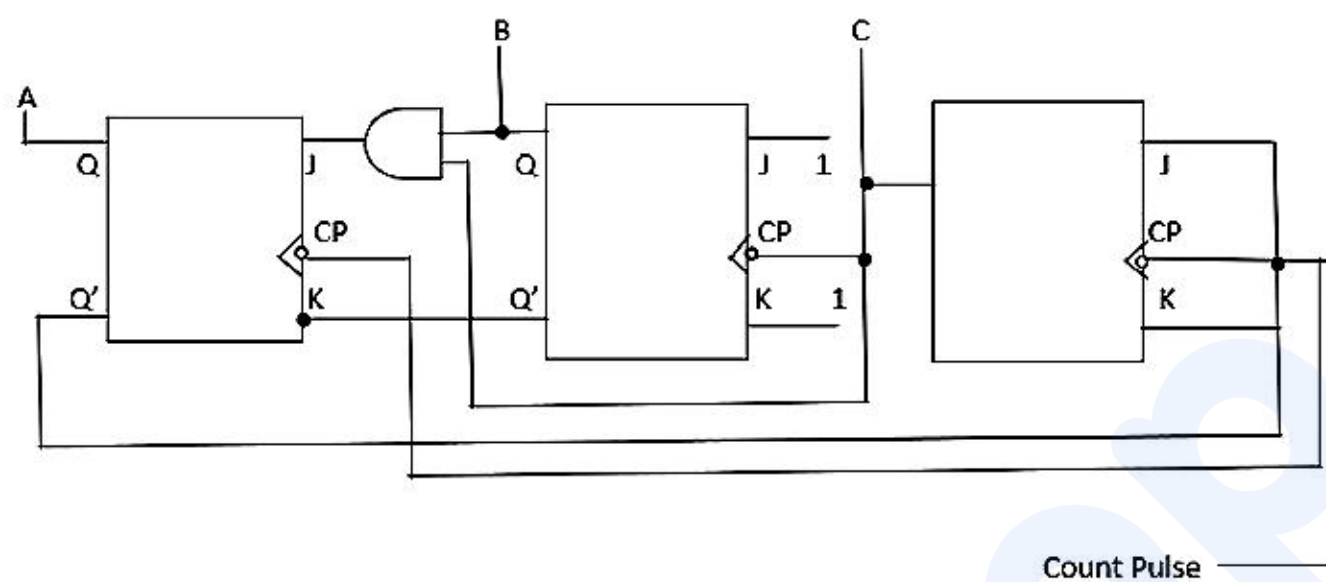

[Question ID = 728][Question Description = S2_qSNz_PG_ETS_Q20]

1. Yes [Option ID = 2909]

2. No [Option ID = 2910]

3. Yes, when all inputs are 1 [Option ID = 2911]

4. Yes, when all inputs are 0 [Option ID = 2912]

Correct Answer :-

• Yes [Option ID = 2909]

21) What is the operation and result of the following instruction, given the register content shown in Figure 1.

JMP 023AH

CS=2000	AX=A407
DS=3000	BX=24B3
SS=4000	CX=0002
ES=3000	DX=FFFA
SP=FFFF	
BP=0009	
SI=4200	
DI=4300	

Figure 1

[Question ID = 729][Question Description = S2_qSNz_PG_ETS_Q21]

1. The content of IP is replaced with 023AH and program execution jumps to 2023BH. [Option ID = 2913]

2. The content of IP is replaced with 023AH and program execution jumps to 2023AH. [Option ID = 2914]

3. The content of IP is replaced with 023AH and program execution jumps to 20239H. [Option ID = 2915]

4. The content of IP is replaced with 023AH and program execution jumps to 2023CH. [Option ID = 2916]

Correct Answer :-

• The content of IP is replaced with 023AH and program execution jumps to 2023BH. [Option ID = 2913]

22) If the data segment register (DS) contains 4000H, what physical address will the instruction MOV, AL, [234BH] read?

[Question ID = 730][Question Description = S2_qSNz_PG_ETS_Q22]

1. 634B0H

[Option ID = 2917]

2. 1BA50H

[Option ID = 2918]

3. 4235BH

[Option ID = 2919]

4. 4234BH

[Option ID = 2920]

Correct Answer :-

- 634B0H

[Option ID = 2917]

23) The three basic structure types used to write the algorithm for a program are sequence, selection and repetition. Which of the following is NOT an advantage of using only these structures when writing the algorithm for a program?

[Question ID = 731][Question Description = S2_qSNz_PG_ETS_Q23]

1. Algorithm is easy to debug. [Option ID = 2923]
2. Algorithm is easy to understand. [Option ID = 2921]
3. Algorithm has very low space complexity. [Option ID = 2924]
4. Algorithm is easy to implement. [Option ID = 2922]

Correct Answer :-

- Algorithm is easy to understand. [Option ID = 2921]

24) Which is lowest priority interrupt of 8086 microprocessor?[Question ID = 732][Question Description = S2_qSNz_PG_ETS_Q24]

1. INTR [Option ID = 2925]
2. NMI [Option ID = 2926]
3. INT_n [Option ID = 2927]
4. SINGLE-STEP [Option ID = 2928]

Correct Answer :-

- INTR [Option ID = 2925]

25) For parallel polarisation, for lossless dielectrics, the expression for Brewster angle for a wave traveling from medium 1 to the medium of refractive indices η_1 and η_2 respectively is

[Question ID = 733][Question Description = S2_qSNz_PG_ETS_Q25]

$$1. \theta = \sin^{-1} \left(\frac{\sqrt{\epsilon_1/\epsilon_2}}{\sqrt{1 + \sqrt{\epsilon_1/\epsilon_2}}} \right)$$

[Option ID = 2929]

$$2. \theta = \sin^{-1} \left(\frac{\sqrt{\epsilon_2/\epsilon_1}}{\sqrt{1 + \epsilon_2/\epsilon_1}} \right)$$

[Option ID = 2930]

$$3. \theta = \sin^{-1} \left(\sqrt{\frac{\epsilon_2}{\epsilon_1}} \right)$$

[Option ID = 2931]

$$4. \theta = \cos^{-1} \left(\sqrt{\frac{\epsilon_1}{\epsilon_2}} \right)$$

[Option ID = 2932]

Correct Answer :-

- $\theta = \sin^{-1} \left(\frac{\sqrt{\epsilon_1/\epsilon_2}}{\sqrt{1 + \sqrt{\epsilon_1/\epsilon_2}}} \right)$

[Option ID = 2929]

26) Vector $\vec{A} = \hat{y}.3 + \hat{z}.2$ and $\vec{B} = \hat{x}.5 + \hat{y}.8$ extend from the origin. Find $\vec{A} \cdot \vec{B}$

Choose the correct answer.

[Question ID = 734][Question Description = S2_qSNz_PG_ETS_Q26]

1. 15 [Option ID = 2933]
2. 16 [Option ID = 2934]
3. 24 [Option ID = 2935]
4. 6 [Option ID = 2936]

Correct Answer :-

- 15 [Option ID = 2933]

- 27) Water flowing in x direction has a rate of $\vec{B}_x = 3yz \text{ liters/minute/m}^2$. The total flow or flux of water through the rectangular area with corners $(0,0,0)$, $(0,3,0)$, $(0,0,2)$ and $(0,3,2)$ m is

[Question ID = 735][Question Description = S2_qSNz_PG_ETS_Q27]

1. 18 liters/minute

[Option ID = 2937]

2. 27 liters/minute

[Option ID = 2938]

3. 3 liters/minute

[Option ID = 2939]

4. 36 liters/minute

[Option ID = 2940]

Correct Answer :-

- 18 liters/minute

[Option ID = 2937]

- 28) The value of transmission line impedance of a coaxial line of internal diameter 'a' and external diameter 'b' is given by the expression:

[Question ID = 736][Question Description = S2_qSNz_PG_ETS_Q28]

1. $Z_0 = 118\sqrt{\epsilon_r} \log\left(\frac{a}{b}\right)$

[Option ID = 2941]

2. $Z_0 = \frac{138}{\sqrt{\epsilon_r}} \log\left(\frac{a}{b}\right)$

[Option ID = 2942]

3. $Z_0 = \frac{138}{\sqrt{\epsilon_r}} \log\left(\frac{b}{a}\right)$

[Option ID = 2943]

4. $Z_0 = \frac{276}{\sqrt{\epsilon_r}} \log\left(\frac{a}{b}\right)$

[Option ID = 2944]

Correct Answer :-

- $Z_0 = 118\sqrt{\epsilon_r} \log\left(\frac{a}{b}\right)$

[Option ID = 2941]

- 29) In a multimode fiber (step index), number of modes passing at an operating wavelength of 1300 nm are 1000, the refractive index of the core is 1.50 and that of the cladding is 1.48. The value of core diameter is:

[Question ID = 737][Question Description = S2_qSNz_PG_ETS_Q29]

1. 100 nm [Option ID = 2945]
 2. 2.5 μm [Option ID = 2946]
 3. 125 μm [Option ID = 2947]
 4. 6.25 μm [Option ID = 2948]

Correct Answer :-

- 100 nm [Option ID = 2945]

- 30) In optical fibers, the Rayleigh scattering is proportional to:[Question ID = 738][Question Description = S2_qSNz_PG_ETS_Q30]

1. $\frac{1}{\lambda}$

[Option ID = 2949]

2. $\frac{1}{\lambda^2}$

[Option ID = 2950]

3. $\frac{1}{\lambda^3}$

[Option ID = 2951]

4. $\frac{1}{\lambda^4}$

A *

[Option ID = 2952]

Correct Answer :-

- $\frac{1}{\lambda}$

[Option ID = 2949]

31) The absolute maximum operating frequency of a converter grade SCR whose turn on time and turn off time are $3 \mu\text{s}$ and $200 \mu\text{s}$ respectively is:

[Question ID = 739][Question Description = S2_qSNz_PG_ETS_Q31]

1. 9.4 kHz [Option ID = 2953]
2. 5.2 kHz [Option ID = 2954]
3. 4.9 kHz [Option ID = 2955]
4. 300 kHz [Option ID = 2956]

Correct Answer :-

- 9.4 kHz [Option ID = 2953]

32) A single phase 220V, 1kW electric room radiator is connected across 220V supply through a triac. For a delay angle of 90° , the value of power dissipated by the radiator is:

[Question ID = 740][Question Description = S2_qSNz_PG_ETS_Q32]

1. 49.985 W [Option ID = 2957]
2. 2500 W [Option ID = 2958]
3. 398.9 W [Option ID = 2959]
4. 500 W [Option ID = 2960]

Correct Answer :-

- 49.985 W [Option ID = 2957]

33) If f_m is modulating frequency and m_f is modulation index, then by the Carson's rule, the bandwidth of an FM signal at the input of a conventional discriminator will be:

[Question ID = 741][Question Description = S2_qSNz_PG_ETS_Q33]

1. $2 f_m (m_f + 1)$ Hz [Option ID = 2961]
2. $2 f_m (m_f - 1)$ Hz [Option ID = 2962]
3. $f_m (2m_f + 1)$ Hz [Option ID = 2963]
4. $f_m (2m_f - 1)$ Hz [Option ID = 2964]

Correct Answer :-

- $2 f_m (m_f + 1)$ Hz [Option ID = 2961]

34) A 10kW carrier is simultaneously modulated by two modulating signals corresponding to a modulation index of 40% and 30%, respectively. The total radiated power will be:

[Question ID = 742][Question Description = S2_qSNz_PG_ETS_Q34]

1. 10 kW [Option ID = 2965]
2. 12.5 kW [Option ID = 2966]
3. 11.25 kW [Option ID = 2967]
4. 10.25 kW [Option ID = 2968]

Correct Answer :-

- 10 kW [Option ID = 2965]

35) If an amplitude modulated wave $10[1+0.6 \cos 2\pi 10^3 t] \cos 2\pi \cdot 10^6 \cdot t$ is to be detected by a linear diode detector, then the time constant will be:

[Question ID = 743][Question Description = S2_qSNz_PG_ETS_Q35]

1. 1.7 msec [Option ID = 2969]
2. 0.17 msec [Option ID = 2970]
3. 17 msec [Option ID = 2971]
4. 0.17 sec [Option ID = 2972]

Correct Answer :-

- 1.7 msec [Option ID = 2969]

36) If the in-phase and quadrature components in an M-ary PSK system are permitted to be independent, then this scheme becomes a:

[Question ID = 744][Question Description = S2_qSNz_PG_ETS_Q36]

1. QAM [Option ID = 2973]
2. DPSK [Option ID = 2974]
3. M-ary QAM [Option ID = 2975]
4. FSK [Option ID = 2976]

Correct Answer :-

- QAM [Option ID = 2973]

37) Which of the following statements is correct?[Question ID = 745][Question Description = S2_qSNz_PG_ETS_Q37]

1. Compensation of a second-order instrument is done to decrease its damping ratio. [Option ID = 2977]
2. If the time constant of a temperature measuring system is increased, it would improve the frequency response of the system. [Option ID = 2978]
3. The mean square value of a random signal cannot be found from a plot of its mean square spectral density against ω . [Option ID = 2979]
4. Compensation of an instrument improves its dynamic characteristics. [Option ID = 2980]

Correct Answer :-

- Compensation of a second-order instrument is done to decrease its damping ratio. [Option ID = 2977]

38) The Q of the coil using series connection measurement method is given by which of the following equations?[Question ID = 746][Question Description = S2_qSNz_PG_ETS_Q38]

$$1. Q_s = \frac{(C_1 - C_2)}{(C_1 Q_1 - C_2 Q_2)}$$

[Option ID = 2981]

$$2. Q_s = \frac{(C_1 - C_2)(Q_1 Q_2)}{(C_1 Q_1 - C_2 Q_2)}$$

[Option ID = 2982]

$$3. Q_s = \frac{(C_1 Q_1 - C_2 Q_2)}{(C_1 - C_2)}$$

[Option ID = 2983]

$$4. Q_s = \frac{C_1 Q_1 - C_2 Q_2}{(C_1 - C_2)(Q_1 Q_2)}$$

[Option ID = 2984]

Correct Answer :-

- $Q_s = \frac{(C_1 - C_2)}{(C_1 Q_1 - C_2 Q_2)}$

[Option ID = 2981]

39) Using a 10-bit conversion, the dynamic range available from an input signal sampled for 4 seconds at a sampling rate of 20 kHz is:

[Question ID = 747][Question Description = S2_qSNz_PG_ETS_Q39]

1. 60 dB [Option ID = 2985]
2. 120 dB [Option ID = 2986]
3. 30 dB [Option ID = 2987]
4. 15 dB [Option ID = 2988]

Correct Answer :-

- 60 dB [Option ID = 2985]

40) If N_i and N_o are the corresponding speeds of input and output shafts of a Gear Dynamometer, respectively, and η is overall mechanical efficiency, the input torque ' τ_i ' applied by mass ' m ' at a distance ' R ' is given by:

[Question ID = 748][Question Description = S2_qSNz_PG_ETS_Q40]

$$1. \tau_i = \frac{m_g R}{\eta \frac{N_o}{N_i} - 1}$$

[Option ID = 2989]

$$2. \tau_i = \frac{m_g R}{\eta \frac{N_i}{N_o} - 1}$$

[Option ID = 2990]

$$3. \tau_i = \frac{m_g R}{1 - \eta \frac{N_o}{N_i}}$$

[Option ID = 2991]

$$4. \tau_i = \frac{m_g R}{1 - \eta \frac{N_i}{N_o}}$$

[Option ID = 2992]

Correct Answer :-

$$\bullet \tau_i = \frac{m_g R}{\eta \frac{N_p}{N_i} - 1}$$

[Option ID = 2989]

41) In enhancement type of MOSFET, at zero gate bias:

- A. Channel conductance is very low
- B. Channel conductance is very high
- C. Channel resistance is very low
- D. Channel resistance is very high

Choose the **correct** answer from the options given below:

[Question ID = 749][Question Description = S2_qSNz_PG_ETS_Q41]

- 1. A and B only [Option ID = 2993]
- 2. A and C only [Option ID = 2994]
- 3. B and D only [Option ID = 2995]
- 4. A and D only [Option ID = 2996]

Correct Answer :-

- A and B only [Option ID = 2993]

42) The maximum operating frequency of a MOSFET is

A. $\frac{\omega_m}{2\pi}$

B. $\frac{\mu_n V_D}{2\pi L^2}$

C. $\frac{\mu_n L^2}{2\pi}$

D. $\frac{\mu_n V_D}{2\pi L}$

Choose the **correct** answer from the options given below:

[Question ID = 750][Question Description = S2_qSNz_PG_ETS_Q42]

- 1. A and C only [Option ID = 2997]
- 2. A and D only [Option ID = 2998]
- 3. A and B only [Option ID = 2999]
- 4. B and D only [Option ID = 3000]

Correct Answer :-

- A and C only [Option ID = 2997]

43) In a Semiconductor Device operation, the current continuity equations are:

A. $\frac{\partial n}{\partial t} = G_n + U_n + \frac{1}{q} \nabla \cdot J_n$

B. $\frac{\partial p}{\partial t} = G_p + U_p + \frac{1}{q} \nabla \cdot J_p$

C. $\frac{\partial p}{\partial t} = G_p - U_p + \frac{1}{q} \nabla \cdot J_p$

D. $\frac{\partial n}{\partial t} = G_n - U_n + \frac{1}{q} \nabla \cdot J_n$

Choose the **correct** answer from the options given below:

[Question ID = 751][Question Description = S2_qSNz_PG_ETS_Q43]

- 1. A and B only
[Option ID = 3001]
- 2. B and C only
[Option ID = 3002]
- 3. C and D only
[Option ID = 3003]
- 4. A and D only
[Option ID = 3004]

Correct Answer :-

- A and B only

[Option ID = 3001]

44) In JFET, the current density in the x-direction is:

- A. $\sigma(x)E_x$
- B. $qN_D\mu E_x$
- C. $\frac{q}{2\epsilon_s}N_D\mu$
- D. $\frac{N_D\mu}{2\epsilon_s}$

Choose the **correct** answer from the options given below:

[Question ID = 752][Question Description = S2_qSNz_PG_ETS_Q44]

1. B and C only [Option ID = 3005]
2. C and D only [Option ID = 3006]
3. A and D only [Option ID = 3007]
4. A and B only [Option ID = 3008]

Correct Answer :-

- B and C only [Option ID = 3005]

45) In JFET, the transconductance in the saturation region is given by:

- A. $\sqrt{\frac{V_G + V_{bi}}{V_P}}$
- B. $g_{\max} \left(1 - \sqrt{\frac{V_G + V_{bi}}{V_P}} \right)$
- C. $qN_D a \mu \frac{z}{L} \left(1 - \sqrt{\frac{V_G + V_{bi}}{V_P}} \right)$
- D. $\left(g_{\max} - \sqrt{\frac{V_G + V_{bi}}{V_P}} \right)$

Choose the **correct** answer from the options given below:

[Question ID = 753][Question Description = S2_qSNz_PG_ETS_Q45]

1. A and B only [Option ID = 3009]
2. B and C only [Option ID = 3010]
3. C and D only [Option ID = 3011]
4. A and D only [Option ID = 3012]

Correct Answer :-

- A and B only [Option ID = 3009]

46) Consider the system represented by $y[n] = 2x[n] + 3$

- A. The system is linear.
- B. The system is non-linear.
- C. The system does not have homogeneity property.
- D. The system follows the additive property.

Choose the **correct** answer from the options given below:

[Question ID = 754][Question Description = S2_qSNz_PG_ETS_Q46]

1. A and D only [Option ID = 3013]
2. A and C only [Option ID = 3014]
3. B and C only [Option ID = 3015]
4. C and D only [Option ID = 3016]

Correct Answer :-

- A and D only [Option ID = 3013]

47) Which of the following statements regarding the Fourier series are correct?

- A. For an even symmetry, only sine terms exist.
- B. For an even symmetry, only cosine terms exist.
- C. For an odd symmetry, only cosine terms exist.
- D. For an odd symmetry, only sine terms exist.

Choose the **correct** answer from the options given below:

[Question ID = 755][Question Description = S2_qSNz_PG_ETS_Q47]

1. A and C only [Option ID = 3017]
2. B and D only [Option ID = 3018]
3. C and D only [Option ID = 3019]
4. A and D only [Option ID = 3020]

Correct Answer :-

- A and C only [Option ID = 3017]

48) Which of the following statements regarding Laplace and Fourier transforms are correct?

A. In order for a function to possess a Laplace transform, it must obey the condition

$$\int_{0^-}^{\infty} |f(t)|e^{-\alpha t} dt > \infty, \alpha \in \text{Re}^+$$

B. In order for a function to possess a Laplace transform, it must obey the condition

$$\int_{0^-}^{\infty} |f(t)|e^{-\alpha t} dt < \infty, \alpha \in \text{Re}^+$$

C. For a function to have a Fourier transform, it must obey the condition $\int_{-\infty}^{\infty} |f(t)| dt > \infty$

D. For a function to have a Fourier transform, it must obey the condition $\int_{-\infty}^{\infty} |f(t)|e^{-\alpha t} dt < \infty$

Choose the **correct** answer from the options given below:

[Question ID = 756][Question Description = S2_qSNz_PG_ETS_Q48]

1. A and C only [Option ID = 3021]
2. B and C only [Option ID = 3022]
3. B and D only [Option ID = 3023]
4. A and D only [Option ID = 3024]

Correct Answer :-

- A and C only [Option ID = 3021]

49) Which of the following statements are correct?

- A. Schottky barriers are established by depositing a metal, such as Tungsten, on a p-type channel.
- B. The transfer characteristics of a depletion type MESFET are similar to those of a depletion type MOSFET.
- C. Maximum operating conditions are determined by the product of drain-to-source voltage and drain current.
- D. A complimentary MOSFET has negligibly small input impedance.

Choose the **correct** answer from the options given below:

[Question ID = 757][Question Description = S2_qSNz_PG_ETS_Q49]

1. A and C only [Option ID = 3025]
2. A and D only [Option ID = 3026]
3. B and C only [Option ID = 3027]
4. B and D only [Option ID = 3028]

Correct Answer :-

- A and C only [Option ID = 3025]

50) Which of the following statements are correct?

- A. A multiplier can be used as a balanced demodulator or detector.
- B. Dynamic range compression is the process of reducing the peak-to-peak variation of a signal to a lower range.
- C. An antilogarithmic amplifier is useful for dynamic range compression.
- D. In a phase-locked loop circuit, the capture range is always larger than the lock range.

Choose the *correct* answer from the options given below:

[Question ID = 758][Question Description = S2_qSNz_PG_ETS_Q50]

1. A and B only [Option ID = 3029]
2. A and C only [Option ID = 3030]
3. B and C only [Option ID = 3031]
4. B and D only [Option ID = 3032]

Correct Answer :-

- A and B only [Option ID = 3029]

51) A single bit comparator compares two numbers A and B and produces three outputs

Y_1 (if $A = B$), Y_2 (if $A > B$) and Y_3 (if $A < B$) as given below:

- A. $Y_1 = A \odot B$; $Y_2 = A\bar{B}$; $Y_3 = \bar{A}B$
- B. $Y_1 = A \oplus B$; $Y_2 = AB$; $Y_3 = \bar{A}\bar{B}$
- C. $Y_1 = A+B$; $Y_2 = A \oplus B$; $Y_3 = A \odot B$
- D. $Y_1 = \bar{A}\bar{B} + AB$; $Y_2 = A\bar{B}$; $Y_3 = \bar{A}B$

Choose the *correct* answer from the options given below:

[Question ID = 759][Question Description = S2_qSNz_PG_ETS_Q51]

1. A and B only [Option ID = 3033]
2. A, B and C only [Option ID = 3034]
3. A, C and D only [Option ID = 3035]
4. A and D only [Option ID = 3036]

Correct Answer :-

- A and B only [Option ID = 3033]

52) For a JK Flip-flop

- A. When $J = 0$, $K = 1$, $Q_{n+1} = 0$
- B. When $J = 1$, $K = 1$, $Q_{n+1} = 1$
- C. When $J = 1$, $K = 1$, $Q_{n+1} = \bar{Q}_n$
- D. When $J = 1$, $K = 0$, $Q_{n+1} = 1$
- E. When $J = 1$, $K = 0$, $Q_{n+1} = 0$

Choose the *correct* answer from the options given below:

[Question ID = 760][Question Description = S2_qSNz_PG_ETS_Q52]

1. A, C and E only
[Option ID = 3037]
2. B and D only
[Option ID = 3038]
3. C and E only
[Option ID = 3039]
4. A, C and D only
[Option ID = 3040]

Correct Answer :-

- A, C and E only

[Option ID = 3037]

53) Which of the following is/are NOT processor control instructions?

- A. STC
- B. CMC
- C. JNO
- D. NOP
- E. CWD

Choose the *correct* answer from the options given below:

[Question ID = 761][Question Description = S2_qSNz_PG_ETS_Q53]

1. A, B and E only [Option ID = 3041]
2. C and E only [Option ID = 3042]
3. C and D only [Option ID = 3043]
4. D and E only [Option ID = 3044]

Correct Answer :-

- A, B and E only [Option ID = 3041]

54) Which of the following are the major steps which are taken to troubleshoot a microcomputer system? Assume all ICs are in the socket.

- A. Identify the symptoms and make a careful visual and tactical inspection.
- B. Check the power supply.
- C. Switch OFF and ON the system.
- D. Check the control signals such as

\overline{RD} , \overline{WR} , ALE, RDY and RESET

Choose the **correct** answer from the options given below:

[Question ID = 762][Question Description = S2_qSNz_PG_ETS_Q54]

1. A and C only
[Option ID = 3045]
2. A, B and D only
[Option ID = 3046]
3. A, B and C only
[Option ID = 3047]
4. C and D only
[Option ID = 3048]

Correct Answer :-

- A and C only

[Option ID = 3045]

55) For small loop antennas:

- A. $\overline{E}_\phi = \frac{120 \pi^2 \sin\theta A}{r^2 \lambda^2}$
- B. $\overline{E}_\phi = \frac{120 \pi^2 [I] \sin\theta A}{r \lambda^2}$
- C. $\overline{H}_\theta = \frac{\pi [I] \sin\theta A}{r \lambda^2}$
- D. $\overline{H}_\theta = \frac{\pi \sin\theta A}{r^2 \lambda^2}$
- E. $\overline{H}_\theta = \frac{120 \pi^2}{r} [I] \sin\theta \frac{A}{\lambda^2}$

Choose the **correct** answer from the options given below:

[Question ID = 763][Question Description = S2_qSNz_PG_ETS_Q55]

1. A and D only [Option ID = 3049]
2. B and D only [Option ID = 3050]
3. B and C only [Option ID = 3051]
4. B and E only [Option ID = 3052]

Correct Answer :-

- A and D only [Option ID = 3049]

56) In 60-degree PWM inverter power supply,

- A. Power devices are made 'ON' for 1/3 of the cycle.
- B. Power devices are made 'OFF' for 1/3 of the cycle.
- C. The phase voltage = 0.57735 V_{supply} .
- D. Line voltage = V_{supply} .
- E. Line voltage < V_{supply} .

Choose the **correct** answer from the options given below:

[Question ID = 764][Question Description = S2_qSNz_PG_ETS_Q56]

1. B, C and E only [Option ID = 3053]
2. C and D only [Option ID = 3054]
3. B, C and D only [Option ID = 3055]
4. A, C and D only [Option ID = 3056]

Correct Answer :-

- B, C and E only [Option ID = 3053]

57) Broadside arrays have

- A. Number of dipoles of unequal size
- B. Number of dipoles equally spaced
- C. Collinear dipoles
- D. Dipoles in phase
- E. Dipoles are 90° out of phase

Choose the **correct** answer from the options given below:

[Question ID = 765][Question Description = S2_qSNz_PG_ETS_Q57]

1. A and B only
[Option ID = 3057]
2. A, C and E only
[Option ID = 3058]
3. B, C and E only
[Option ID = 3059]
4. B, C and D only
[Option ID = 3060]

Correct Answer :-

- A and B only

[Option ID = 3057]

58) Following equations are given for retarded time-varying fields

- A. $\nabla^2 V = -\rho/\epsilon + \omega^2\mu\epsilon V$
- B. $\nabla^2 V = \rho/\epsilon + \omega^2\mu\epsilon V$
- C. $\nabla^2 A = -\mu\bar{j} + \omega^2\mu\epsilon\bar{j}$
- D. $\nabla^2 A = \mu\bar{j} + \omega^2\mu\epsilon\bar{j}$

Choose the **correct** answer from the options given below:

[Question ID = 766][Question Description = S2_qSNz_PG_ETS_Q58]

1. A and D only [Option ID = 3061]
2. A and C only [Option ID = 3062]
3. B and C only [Option ID = 3063]
4. B and D only [Option ID = 3064]

Correct Answer :-

- A and D only [Option ID = 3061]

59) Which of the following statements are correct?

- A. DSB-SC modulation is well suited for point to point communication involving one transmitter and one receiver.
- B. VSB modulation is a linear modulation scheme.
- C. SSB is a non-linear modulation scheme.
- D. FM is a linear modulation scheme.

Choose the **correct** answer from the options given below:

[Question ID = 767][Question Description = S2_qSNz_PG_ETS_Q59]

1. A and B only [Option ID = 3065]
2. A and C only [Option ID = 3066]
3. B and C only [Option ID = 3067]
4. B and D only [Option ID = 3068]

Correct Answer :-

- A and B only [Option ID = 3065]

60) Which of the following statements are correct?

- A. M-ary modulation scheme is preferable where the bandwidth requirement is important.
- B. M-ary PSK system considers 'M' different phases in the range ' $\pi/2$ '.
- C. In M-ary modulation scheme, only coherent detection is possible.
- D. M-ary QAM scheme uses ' m^2 ' carrier signals having the same frequency.

Choose the *correct* answer from the options given below:

[Question ID = 768][Question Description = S2_qSNz_PG_ETS_Q60]

1. A and B only [Option ID = 3069]
2. A and C only [Option ID = 3070]
3. B and C only [Option ID = 3071]
4. C and D only [Option ID = 3072]

Correct Answer :-

- A and B only [Option ID = 3069]

61) Which of the following statements are correct?

- A. If the intermediate frequency is too high, poor selectivity results even if sharp cutoff filters are used in the IF stage.
- B. A high value of intermediate frequency increases tracking difficulties.
- C. As the intermediate frequency is lowered, image frequency rejection becomes better.
- D. A very low intermediate frequency can make the selectivity too sharp.

Choose the *correct* answer from the options given below:

[Question ID = 769][Question Description = S2_qSNz_PG_ETS_Q61]

1. A and B only [Option ID = 3073]
2. B and C only [Option ID = 3074]
3. C and D only [Option ID = 3075]
4. B and D only [Option ID = 3076]

Correct Answer :-

- A and B only [Option ID = 3073]

62) A diac is

- A. a two electrode, bidirectional avalanche diode.
- B. a device which conducts below the breakover voltage.
- C. a unidirectional resistive device.
- D. designed to supply large gate current.
- E. used to supply the voltage to the motors.

Choose the *correct* answer from the options given below:

[Question ID = 770][Question Description = S2_qSNz_PG_ETS_Q62]

1. A, B and C only [Option ID = 3077]
2. A, C and D only [Option ID = 3078]
3. A and D only [Option ID = 3079]
4. A, B and E only [Option ID = 3080]

Correct Answer :-

- A, B and C only [Option ID = 3077]

63) Response time of photodiode has

- A. dependance on transit time.
- B. dependance on diffusion time.
- C. RC time constant dependance.

D. $t_d = \frac{W}{V_d}$

E. $t_d = \frac{V_d}{W}$

Choose the **correct** answer from the options given below:

[Question ID = 771][Question Description = S2_qSNz_PG_ETS_Q63]

1. A, B, C and D only [Option ID = 3081]
2. B, C and E only [Option ID = 3082]
3. A and B only [Option ID = 3083]
4. A, C, and E only [Option ID = 3084]

Correct Answer :-

- A, B, C and D only [Option ID = 3081]

64) Which of the following statements are correct?

- A. For dynamic measurements using resistance strain gauges, temperature compensation is not necessary.
- B. Eddy current type of transducer gives an output proportional to velocity.
- C. A variable capacitance type transducer gives an output proportional to acceleration.
- D. A piezoelectric transducer cannot be used to measure static variables.

Choose the **correct** answer from the options given below:

[Question ID = 772][Question Description = S2_qSNz_PG_ETS_Q64]

1. A and B only [Option ID = 3085]
2. B and D only [Option ID = 3086]
3. B and C only [Option ID = 3087]
4. A and D only [Option ID = 3088]

Correct Answer :-

- A and B only [Option ID = 3085]

65) Which of the following statements are correct?

- A. Ultrasonic method for liquid level measurement is not preferred in industrial applications.
- B. In a pH meter, the glass electrode is the reference electrode.
- C. A chromatograph is used for analysing the composition of a gas.
- D. The production of Korotkoff sounds in indirect blood pressure measurement is due to pressure pulses produced due to the difference in systolic and diastolic blood pressure.

Choose the **correct** answer from the options given below:

[Question ID = 773][Question Description = S2_qSNz_PG_ETS_Q65]

1. A and C only [Option ID = 3089]
2. B and C only [Option ID = 3090]
3. B and D only [Option ID = 3091]
4. C and D only [Option ID = 3092]

Correct Answer :-

- A and C only [Option ID = 3089]

66) Match **List I** with **List II**

List I	List II
A. Ideal MIS diode (n-type)	I. $\frac{L}{v_s}$
B. Extrinsic Debyelength (hole)	II. $\frac{\mu E_x}{1 + \mu E_x / v_s}$
C. Field dependent mobility	III. $\sqrt{\frac{kT\epsilon_s}{P_{PO}q^2}}$
D. Transit time for velocity saturation	IV. $\phi_{ms} = \phi_m - \left(x + \frac{E_g}{2q} - \psi_B\right)$

Choose the **correct** answer from the options given below:

[Question ID = 774][Question Description = S2_qSNz_PG_ETS_Q66]

1. A - IV, B - III, C - II, D - I [Option ID = 3093]
2. A - I, B - IV, C - III, D - II [Option ID = 3094]
3. A - II, B - I, C - IV, D - III [Option ID = 3095]
4. A - III, B - II, C - I, D - IV [Option ID = 3096]

Correct Answer :-

- A - IV, B - III, C - II, D - I [Option ID = 3093]

67) Match List I with List II

List I	List II
A. Diffusion	I. PMMA
B. Oxidation	II. Proximity Printing
C. UV Resist	III. $\frac{\partial C(x,t)}{\partial t} = \frac{\partial J(x,t)}{\partial x}$
D. X-ray Lithography	IV. Deal and Grove's Model

Choose the correct answer from the options given below:

[Question ID = 775][Question Description = S2_qSNz_PG_ETS_Q67]

1. A - II, B - III, C - IV, D - I [Option ID = 3097]
2. A - III, B - IV, C - I, D - II [Option ID = 3098]
3. A - IV, B - I, C - II, D - III [Option ID = 3099]
4. A - I, B - II, C - III, D - IV [Option ID = 3100]

Correct Answer :-

- A - II, B - III, C - IV, D - I [Option ID = 3097]

68) Match List I with List II

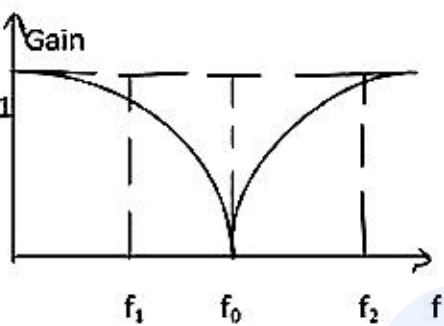
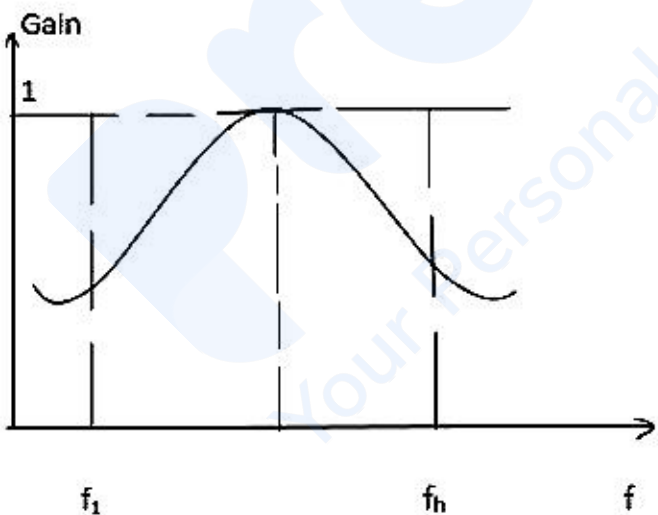
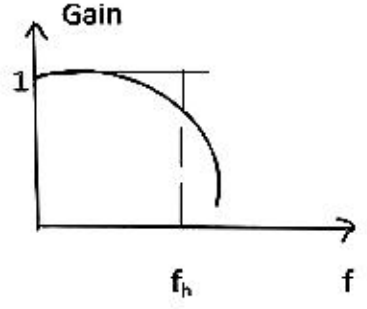
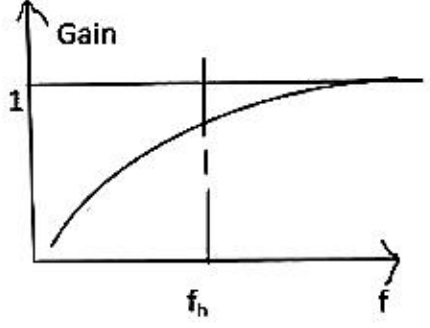
List I	List II
A. Low Pass Filter	I. 
B. High Pass Filter	II. 
C. Band Pass Filter	III. 
D. Band Reject Filter	IV. 

Choose the **correct** answer from the options given below:

[Question ID = 776][Question Description = S2_qSNz_PG_ETS_Q68]

1. A - II, B - III, C - IV, D - I [Option ID = 3101]
2. A - II, B - I, C - IV, D - III [Option ID = 3102]
3. A - III, B - IV, C - I, D - II [Option ID = 3103]
4. A - III, B - IV, C - II, D - I [Option ID = 3104]

Correct Answer :-

- A - II, B - III, C - IV, D - I [Option ID = 3101]

69) Match **List I** with **List II**

List I	List II
JFET - Bias	Characteristic Equation
A. Self-bias	I. $I_D = \frac{V_{SS} - V_{GS}}{R_S}$
B. Voltage-divider bias	II. $I_D = \frac{V_{EE} - V_{BE}}{R_E}$
C. Source bias	III. $V_{GS} = -I_D R_S$
D. Current-source bias	IV. $I_D = \frac{V_G - V_{GS}}{R_S}$

Choose the **correct** answer from the options given below:

[Question ID = 777][Question Description = S2_qSNz_PG_ETS_Q69]

1. A - III, B - IV, C - II, D - I [Option ID = 3105]
2. A - I, B - III, C - II, D - IV [Option ID = 3106]
3. A - II, B - IV, C - I, D - III [Option ID = 3107]
4. A - III, B - IV, C - I, D - II [Option ID = 3108]

Correct Answer :-

- A - III, B - IV, C - II, D - I [Option ID = 3105]

70) Match **List I** with **List II**

List I	List II															
Logic gate	Truth table															
A. Negative OR	I. <table border="1"> <tr><td>A</td><td>B</td><td>F</td></tr> <tr><td>0</td><td>0</td><td>1</td></tr> <tr><td>0</td><td>1</td><td>0</td></tr> <tr><td>1</td><td>0</td><td>0</td></tr> <tr><td>1</td><td>1</td><td>0</td></tr> </table>	A	B	F	0	0	1	0	1	0	1	0	0	1	1	0
A	B	F														
0	0	1														
0	1	0														
1	0	0														
1	1	0														
B. Exclusive NOR	II. <table border="1"> <tr><td>A</td><td>B</td><td>F</td></tr> <tr><td>0</td><td>0</td><td>1</td></tr> <tr><td>0</td><td>1</td><td>1</td></tr> <tr><td>1</td><td>0</td><td>1</td></tr> <tr><td>1</td><td>1</td><td>0</td></tr> </table>	A	B	F	0	0	1	0	1	1	1	0	1	1	1	0
A	B	F														
0	0	1														
0	1	1														
1	0	1														
1	1	0														
C. Exclusive OR	III. <table border="1"> <tr><td>A</td><td>B</td><td>F</td></tr> <tr><td>0</td><td>0</td><td>1</td></tr> <tr><td>0</td><td>1</td><td>0</td></tr> <tr><td>1</td><td>0</td><td>0</td></tr> <tr><td>1</td><td>1</td><td>1</td></tr> </table>	A	B	F	0	0	1	0	1	0	1	0	0	1	1	1
A	B	F														
0	0	1														
0	1	0														
1	0	0														
1	1	1														
D. Negative AND	IV. <table border="1"> <tr><td>A</td><td>B</td><td>F</td></tr> <tr><td>0</td><td>0</td><td>0</td></tr> <tr><td>0</td><td>1</td><td>1</td></tr> <tr><td>1</td><td>0</td><td>1</td></tr> <tr><td>1</td><td>1</td><td>0</td></tr> </table>	A	B	F	0	0	0	0	1	1	1	0	1	1	1	0
A	B	F														
0	0	0														
0	1	1														
1	0	1														
1	1	0														

Choose the **correct** answer from the options given below:

[Question ID = 778][Question Description = S2_qSNz_PG_ETS_Q70]

1. A - I, B - II, C - IV, D - III [Option ID = 3109]
2. A - IV, B - I, C - II, D - III [Option ID = 3110]
3. A - I, B - IV, C - III, D - II [Option ID = 3111]
4. A - II, B - III, C - IV, D - I [Option ID = 3112]

Correct Answer :-

- A - I, B - II, C - IV, D - III [Option ID = 3109]

71) Match **List I** with **List II**

List I	List II
Assembly code	Content of register A after the code
A. MOV A, #37H CPL A	I. 02

B. MOV A, #37H ANL A, #0CAH	II. FFH
C. MOV A, #37H ORL A, #0CAH	III. F0H
D. MOV A, #37H XRL A, #0CAH	IV. C8H

Choose the correct answer from the options given below:

[Question ID = 779][Question Description = S2_qSNz_PG_ETS_Q71]

1. A - IV, B - III, C - I, D - II

[Option ID = 3113]

2. A - I, B - II, C - III, D - IV

[Option ID = 3114]

3. A - IV, B - I, C - III, D - II

[Option ID = 3115]

4. A - IV, B - I, C - II, D - III

[Option ID = 3116]

Correct Answer :-

- A - IV, B - III, C - I, D - II

[Option ID = 3113]

72) Match List I with List II

List I	List II
US New Military Bands for Microwaves	Frequency range in GHz
A. H band	I. 2.000-3.000 GHz
B. J band	II. 4.000-6.000 GHz
C. G band	III. 6.000-8.000 GHz
D. E band	IV. 10.000-20.000 GHz

Choose the correct answer from the options given below:

[Question ID = 780][Question Description = S2_qSNz_PG_ETS_Q72]

1. A - I, B - III, C - II, D - IV [Option ID = 3117]

2. A - III, B - IV, C - II, D - I [Option ID = 3118]

3. A - I, B - II, C - III, D - IV [Option ID = 3119]

4. A - III, B - II, C - IV, D - I [Option ID = 3120]

Correct Answer :-

- A - I, B - III, C - II, D - IV [Option ID = 3117]

73) Match List I with List II

List I	List II
A. FDMA	I. Frequency Hopping
B. TDMA	II. Guard Band
C. CDMA	III. Onboard Switching
D. SDMA	IV. Guard Time

Choose the correct answer from the options given below:

[Question ID = 781][Question Description = S2_qSNz_PG_ETS_Q73]

1. A - II, B - IV, C - I, D - III [Option ID = 3121]

2. A - IV, B - II, C - III, D - I [Option ID = 3122]

3. A - IV, B - II, C - I, D - III [Option ID = 3123]

4. A - II, B - I, C - III, D - IV [Option ID = 3124]

Correct Answer :-

- A - II, B - IV, C - I, D - III [Option ID = 3121]

74) Match List I with List II

List I	List II
f(t)	F(S)
A. e^{-at}	I. $\frac{s}{s^2 + \omega^2}$
B. te^{at}	II. $\frac{\omega}{s^2 + \omega^2}$
C. $\sin \omega t$	III. 1

	$(s-a)^2$
D. $\cos wt$	IV. $\frac{1}{(s+a)}$

Choose the **correct** answer from the options given below:

[Question ID = 782][Question Description = S2_qSNz_PG_ETS_Q74]

1. A - I, B - II, C - IV, D - III [Option ID = 3125]
2. A - III, B - II, C - I, D - IV [Option ID = 3126]
3. A - IV, B - III, C - I, D - II [Option ID = 3127]
4. A - IV, B - III, C - II, D - I [Option ID = 3128]

Correct Answer :-

- A - I, B - II, C - IV, D - III [Option ID = 3125]

75) Match List I with List II

List I	List II
Performance Characteristic	Definition
A. Correction	I. Nearness of indicated value to the true value of the quantity being measured
B. Precision	II. Opposite of error
C. Accuracy	III. Closeness with which the same value of input quantity is measured under different conditions
D. Reproducibility	IV. Degree of refinement with which a measured value is stated

Choose the correct answer from the options given below:

[Question ID = 783][Question Description = S2_qSNz_PG_ETS_Q75]

1. A - IV, B - I, C - II, D - III
[Option ID = 3129]
2. A - II, B - I, C - IV, D - III
[Option ID = 3130]
3. A - II, B - IV, C - I, D - III
[Option ID = 3131]
4. A - III, B - II, C - IV, D - I
[Option ID = 3132]

Correct Answer :-

- A - IV, B - I, C - II, D - III
[Option ID = 3129]

76) Arrange the following in ascending order of their conductivity.

- A. Silicon dioxide
- B. Intrinsic Silicon
- C. Extrinsic Silicon
- D. Aluminium

Choose the **correct** answer from the options given below

[Question ID = 784][Question Description = S2_qSNz_PG_ETS_Q76]

1. A, B, C, D [Option ID = 3133]
2. B, C, D, A [Option ID = 3134]
3. C, D, A, B [Option ID = 3135]
4. D, A, B, C [Option ID = 3136]

Correct Answer :-

- A, B, C, D [Option ID = 3133]

77) Arrange the following in ascending order of their bandgap (at -300K)

- A. GaN
- B. GaP
- C. GaAs

D. Si

Choose the *correct* answer from the options given below

[Question ID = 785][Question Description = S2_qSNz_PG_ETS_Q77]

1. D, C, B, A [Option ID = 3137]
2. C, D, A, B [Option ID = 3138]
3. B, A, C, D [Option ID = 3139]
4. A, B, D, C [Option ID = 3140]

Correct Answer :-

- D, C, B, A [Option ID = 3137]

78) Consider the following circuits and arrange them in ascending order of their complexity.

- A. First order low pass filter
- B. Sallen-Key filter
- C. Fourth order Butterworth low pass filter
- D. Non-inverting amplifier

Choose the *correct* answer from the options given below

[Question ID = 786][Question Description = S2_qSNz_PG_ETS_Q78]

1. D, A, C, B [Option ID = 3141]
2. D, A, B, C [Option ID = 3142]
3. C, B, A, D [Option ID = 3143]
4. B, C, D, A [Option ID = 3144]

Correct Answer :-

- D, A, C, B [Option ID = 3141]

79) Arrange the following components of dual-slot integrating A/D converter in order of their appearance while moving from input to output stage.

- A. Comparator
- B. Control
- C. Integrator
- D. Counter

Choose the *correct* answer from the options given below

[Question ID = 787][Question Description = S2_qSNz_PG_ETS_Q79]

1. C, A, D, B [Option ID = 3145]
2. C, A, B, D [Option ID = 3146]
3. C, B, A, D [Option ID = 3147]
4. C, D, A, B [Option ID = 3148]

Correct Answer :-

- C, A, D, B [Option ID = 3145]

80) A number may be represented in various number systems. Arrange the following number systems in ascending order based on the number of bits needed to represent the same number.

- A. Binary
- B. Decimal
- C. Hexadecimal
- D. Octal

Choose the *correct* answer from the options given below

[Question ID = 788][Question Description = S2_qSNz_PG_ETS_Q80]

1. D, A, B, C [Option ID = 3149]
2. B, C, A, D [Option ID = 3150]
3. C, B, D, A [Option ID = 3151]
4. A, B, C, D [Option ID = 3152]

Correct Answer :-

- D, A, B, C [Option ID = 3149]

81) Arrange the different operations to run instructions in a computer system, from the beginning to last stage

- A. Instruction decode
- B. Instruction fetch

C. Operand fetch

D. Execute

Choose the *correct* answer from the options given below

[Question ID = 789][Question Description = S2_qSNz_PG_ETS_Q81]

1. A, B, C, D [Option ID = 3153]
2. B, A, C, D [Option ID = 3154]
3. C, D, A, B [Option ID = 3155]
4. D, B, C, A [Option ID = 3156]

Correct Answer :-

- A, B, C, D [Option ID = 3153]

82) Arrange the following antennas in ascending order of their radiation resistance.

- A. Short dipole ($L = \lambda/10$) ($I_{av} = I_0$)
- B. Short dipole ($L = \lambda/10$) ($I_{av} = I_0/2$)
- C. Linear $\lambda/2$ dipole (sinusoidal current distribution)
- D. Small Loop (square loop) single turn of ($L = \lambda/10$)

Choose the *correct* answer from the options given below

[Question ID = 790][Question Description = S2_qSNz_PG_ETS_Q82]

1. B, D, A, C [Option ID = 3157]
2. C, B, A, D [Option ID = 3158]
3. D, B, A, C [Option ID = 3159]
4. B, D, C, A [Option ID = 3160]

Correct Answer :-

- B, D, A, C [Option ID = 3157]

83) Arrange the following modulation systems in decreasing order of the bandwidth requirements.

- A. Single Side Band
- B. Double Side Band
- C. Vestigial Side Band
- D. Frequency Modulation

Choose the *correct* answer from the options given below

[Question ID = 791][Question Description = S2_qSNz_PG_ETS_Q83]

1. A, C, D, B [Option ID = 3161]
2. C, A, B, D [Option ID = 3162]
3. D, B, A, C [Option ID = 3163]
4. D, B, C, A [Option ID = 3164]

Correct Answer :-

- A, C, D, B [Option ID = 3161]

84) Arrange the following system types in ascending order of their intersection with 0 dB axis.

- A. Type N system
- B. Type 3 system
- C. Type 2 system
- D. Type 4 system

Choose the *correct* answer from the options given below

[Question ID = 792][Question Description = S2_qSNz_PG_ETS_Q84]

1. A, D, B, C [Option ID = 3165]
2. C, B, D, A [Option ID = 3166]
3. C, B, A, D [Option ID = 3167]
4. D, C, B, A [Option ID = 3168]

Correct Answer :-

- A, D, B, C [Option ID = 3165]

85) Arrange the following manometric liquid in ascending order of their specific gravity at 20° C.

- A. Water
- B. Carbon tetrachloride
- C. Transformer Oil
- D. Mercury
- E. Dibutylphthalate

Choose the *correct* answer from the options given below

[Question ID = 793][Question Description = S2_qSNz_PG_ETS_Q85]

1. A, C, B, E, D

[Option ID = 3169]

2. A, D, B, C, E

[Option ID = 3170]

3. C, A, E, B, D

[Option ID = 3171]

4. B, C, A, E, D

[Option ID = 3172]

Correct Answer :-

- A, C, B, E, D

[Option ID = 3169]

86) Given below are two statements, one is labelled as Assertion A and the other is labelled as Reason R

Assertion A: When MOSFET is in conductive state, the saturation current flow after the channel is pinched off.

Reason R: The substrate bias affects the threshold voltage of a MOSFET.

In light of the above statements, choose the *most appropriate* answer from the options given below

[Question ID = 794][Question Description = S2_qSNz_PG_ETS_Q86]

1. Both A and R are correct and R is the correct explanation of A

[Option ID = 3173]

2. Both A and R are correct but R is NOT the correct explanation of A

[Option ID = 3174]

3. A is correct but R is not correct

[Option ID = 3175]

4. A is not correct but R is correct

[Option ID = 3176]

Correct Answer :-

- Both A and R are correct and R is the correct explanation of A

[Option ID = 3173]

87) Given below are two statements

Statement I: The scaling theorem relates scale changes in frequency domain to the consequent changes in scale in the time domain.

Statement II: The scaling theorem is not applicable to an impulse signal.

In light of the above statements, choose the *correct* answer from the options given below

[Question ID = 795][Question Description = S2_qSNz_PG_ETS_Q87]

1. Both Statement I and Statement II are true [Option ID = 3177]

2. Both Statement I and Statement II are false [Option ID = 3178]

3. Statement I is true but Statement II is false [Option ID = 3179]

4. Statement I is false but Statement II is true [Option ID = 3180]

Correct Answer :-

- Both Statement I and Statement II are true [Option ID = 3177]

88) Given below are two statements, one is labelled as Assertion A and the other is labelled as Reason R

Assertion A: A reflex klystron is a single cavity high power generator of efficiency 90%.

Reason R: The loop gain is unity with a phase shift of multiple of 2π .

In light of the above statements, choose the *most appropriate* answer from the options given below

[Question ID = 796][Question Description = S2_qSNz_PG_ETS_Q88]

1. Both A and R are correct and R is the correct explanation of A

[Option ID = 3181]

2. Both A and R are correct but R is NOT the correct explanation of A

[Option ID = 3182]

3. A is correct but R is not correct

[Option ID = 3183]

4. A is not correct but R is correct

[Option ID = 3184]

Correct Answer :-

- Both A and R are correct and R is the correct explanation of A

[Option ID = 3181]

89) Given below are two statements, one is labelled as Assertion A and the other is labelled as Reason R

Assertion A: Major advantage of DRAM is that the capacitor cell never loses its charge and hence there is no need to refresh periodically.

Reason R: When DRAM is being refreshed, the data cannot be accessed.

In light of the above statements, choose the *correct* answer from the options given below

[Question ID = 797][Question Description = S2_qSNz_PG_ETS_Q89]

1. Both A and R are true and R is the correct explanation of A

[Option ID = 3185]

2. Both A and R are true but R is NOT the correct explanation of A

[Option ID = 3186]

3. A is true but R is false

[Option ID = 3187]

4. A is false but R is true

[Option ID = 3188]

Correct Answer :-

- Both A and R are true and R is the correct explanation of A

[Option ID = 3185]

90) Given below are two statements

Statement I: By bringing together the computational capability of microelectronics with the perception and control capabilities of microminiaturized sensors and actuators, MEMS technologies are enabling smart systems on a chip to be mass-produced.

Statement II: While considering IoT deployment, data integrity and authenticity are no more security concerns at the sensor node level.

In light of the above statements, choose the *correct* answer from the options given below

[Question ID = 798][Question Description = S2_qSNz_PG_ETS_Q90]

1. Both Statement I and Statement II are true [Option ID = 3189]

2. Both Statement I and Statement II are false [Option ID = 3190]

3. Statement I is true but Statement II is false [Option ID = 3191]

4. Statement I is false but Statement II is true [Option ID = 3192]

Correct Answer :-

- Both Statement I and Statement II are true [Option ID = 3189]

Topic:- ElectSci_SHAAN_NOV21B

1) Read the passage given below and answer the question

The Metal Oxide Semiconductor Field Effect Transistor (MOSFET) is the most important device at the forefront of high-density integrated circuits such as microprocessors and semiconductor memories. It is also becoming an important power device. The principle of the surface field-effect transistor was first proposed in the 1930s and the first MOSFET was reported in 1960 using the Si-SiO₂ system. The current in MOSFET is transported by carriers of one polarity only and hence it is usually referred to as a unipolar device. Although MOSFETs have been made with various semiconductors, such as Ge, Si, and GaAs and use various insulators such as SiO₂, Si₃N₄ and Al₂O₃, the most important system is Si-SiO₂.

The drain current density including both drift and diffusion component is given by:

[Question ID = 799][Question Description = S2_qSNz_PG_ETS_Q91]

1. $q\mu_n n E_y - qD_n \nabla n$

[Option ID = 3193]

2. $qnE_y + qD_n \nabla_n$
 [Option ID = 3194]
3. $qn\mu_n + qD_n \nabla_n$
 [Option ID = 3195]
4. $q\mu_n \cdot nE_y + qD_n \nabla_n$
 [Option ID = 3196]

Correct Answer :-

- $q\mu_n \cdot nE_y - qD_n \nabla_n$
 [Option ID = 3193]

2) Read the passage given below and answer the question

The Metal Oxide Semiconductor Field Effect Transistor (MOSFET) is the most important device at the forefront of high-density integrated circuits such as microprocessors and semiconductor memories. It is also becoming an important power device. The principle of the surface field-effect transistor was first proposed in the 1930s and the first MOSFET was reported in 1960 using the Si-SiO₂ system. The current in MOSFET is transported by carriers of one polarity only and hence it is usually referred to as a unipolar device. Although MOSFETs have been made with various semiconductors, such as Ge, Si, and GaAs and use various insulators such as SiO₂, Si₃N₄ and Al₂O₃, the most important system is Si-SiO₂.

The threshold voltage under idealised conditions is:

[Question ID = 800][Question Description = S2_qSNz_PG_ETS_Q92]

1. $V_T = 2\psi_B$
 [Option ID = 3197]
2. $V_T = 2\psi_B - \frac{\sqrt{2\epsilon_s q N_A}}{C_i}$
 [Option ID = 3198]
3. $V_T = 2\psi_B + \frac{\sqrt{2\epsilon_s q N_A (2\psi_B)}}{C_i}$
 [Option ID = 3199]
4. $V_T = \frac{\sqrt{2\epsilon_s q N_A (\psi_B)}}{C_i} + \psi_B$
 [Option ID = 3200]

Correct Answer :-

- $V_T = 2\psi_B$
 [Option ID = 3197]

3) Read the passage given below and answer the question

The Metal Oxide Semiconductor Field Effect Transistor (MOSFET) is the most important device at the forefront of high-density integrated circuits such as microprocessors and semiconductor memories. It is also becoming an important power device. The principle of the surface field-effect transistor was first proposed in the 1930s and the first MOSFET was reported in 1960 using the Si-SiO₂ system. The current in MOSFET is transported by carriers of one polarity only and hence it is usually referred to as a unipolar device. Although MOSFETs have been made with various semiconductors, such as Ge, Si, and GaAs and use various insulators such as SiO₂, Si₃N₄ and Al₂O₃, the most important system is Si-SiO₂.

The channel resistance of an elemental section dy is

[Question ID = 801][Question Description = S2_qSNz_PG_ETS_Q93]

1. $\frac{dy}{\mathcal{L}\mu_n}$
 [Option ID = 3201]
2. $\frac{dy}{\mathcal{L}\mu_n |Q_n(y)|}$
 [Option ID = 3202]
3. $\frac{dy}{|Q_n(y)| \mathcal{L}}$

[Option ID = 3203]

$$4. \frac{dy}{\mu_n |Q_n(y)|}$$

[Option ID = 3204]

Correct Answer :-

- $\frac{dy}{\mu_n}$

[Option ID = 3201]

4) Read the passage given below and answer the question

The Metal Oxide Semiconductor Field Effect Transistor (MOSFET) is the most important device at the forefront of high-density integrated circuits such as microprocessors and semiconductor memories. It is also becoming an important power device. The principle of the surface field-effect transistor was first proposed in the 1930s and the first MOSFET was reported in 1960 using the Si-SiO₂ system. The current in MOSFET is transported by carriers of one polarity only and hence it is usually referred to as a unipolar device. Although MOSFETs have been made with various semiconductors, such as Ge, Si, and GaAs and use various insulators such as SiO₂, Si₃N₄ and Al₂O₃, the most important system is Si-SiO₂.

In n-channel MOSFET, the charge induced in the inversion layer per unit area at a distance y from the source is:

[Question ID = 802][Question Description = S2_qSNz_PG_ETS_Q94]

$$1. Q_n(y) = [V_G + \psi_s(y)] C_i - Q_B(y)$$

[Option ID = 3205]

$$2. Q_n(y) = -[V_G - \psi_s(y)] C_i - Q_B(y)$$

[Option ID = 3206]

$$3. Q_n(y) = -[V_G - \psi_s(y)] C_i + Q_B(y)$$

[Option ID = 3207]

$$4. Q_n(y) = -[V_G + \psi_s(y)] C_i + Q_B(y)$$

[Option ID = 3208]

Correct Answer :-

- $Q_n(y) = [V_G + \psi_s(y)] C_i - Q_B(y)$

[Option ID = 3205]

5) Read the passage given below and answer the question

The Metal Oxide Semiconductor Field Effect Transistor (MOSFET) is the most important device at the forefront of high-density integrated circuits such as microprocessors and semiconductor memories. It is also becoming an important power device. The principle of the surface field-effect transistor was first proposed in the 1930s and the first MOSFET was reported in 1960 using the Si-SiO₂ system. The current in MOSFET is transported by carriers of one polarity only and hence it is usually referred to as a unipolar device. Although MOSFETs have been made with various semiconductors, such as Ge, Si, and GaAs and use various insulators such as SiO₂, Si₃N₄ and Al₂O₃, the most important system is Si-SiO₂.

The one dimensional Poisson equation for the surface space charge region at the drain is:

[Question ID = 803][Question Description = S2_qSNz_PG_ETS_Q95]

$$1. \frac{\partial^2 \psi}{\partial x^2} = -\frac{q}{\epsilon_s} (N_D^+ - N_A^- + p - n)$$

[Option ID = 3209]

$$2. \frac{\partial^2 \psi}{\partial x^2} = \frac{q}{\epsilon_s} (N_D^+ + N_A^- - p - n)$$

[Option ID = 3210]

$$3. \frac{\partial^2 \psi}{\partial x^2} = -\frac{q}{\epsilon_s} (N_A^- - N_D^+ - p - n)$$

[Option ID = 3211]

$$4. \frac{\partial^2 \psi}{\partial x^2} = \frac{q}{\epsilon_s} (N_A^- - N_D^+ + p - n)$$

[Option ID = 3212]

Correct Answer :-

$$\bullet \frac{\partial^2 \psi}{\partial x^2} = -\frac{q}{\epsilon_s} (N_D^+ - N_A^- + p - n)$$

[Option ID = 3209]

Topic:- ElectSci_SHAAN_NOV21C

1) Read the passage given below and answer the question

One very common use of filters is bandwidth limiting. Analog filter implementation consists of two categories: passive and active. The active filters are further classified as high-pass, low-pass, band-pass, band-reject and all-pass. Butterworth and Chebyshev are commonly used practical filters. The key characteristic of Butterworth filter is that it has a flat passband and stopband. The practical limit for most RC active filters is close to 30 kHz. The Chebyshev response is referred to as an equiripple response because passband is characterised by a series of ripples that have equal maximum levels and equal minimum levels besides exhibiting flat stopband.

Which of the following statements is NOT correct for a Chebyshev Filter?

[Question ID = 804][Question Description = S2_qSNz_PG_ETS_Q96]

1. Chebyshev filter tends to exhibit ringing effect with transient signals.

[Option ID = 3213]

2. Time delay and phase characteristics of Chebyshev filter are comparatively better than that of Butterworth filter.

[Option ID = 3214]

3. Chebyshev filters have a sharper slope than Butterworth filters.

[Option ID = 3215]

4. Chebyshev filters are capable of achieving more attenuation in stopband.

[Option ID = 3216]

Correct Answer :-

- Chebyshev filter tends to exhibit ringing effect with transient signals.

[Option ID = 3213]

2) Read the passage given below and answer the question

One very common use of filters is bandwidth limiting. Analog filter implementation consists of two categories: passive and active. The active filters are further classified as high-pass, low-pass, band-pass, band-reject and all-pass. Butterworth and Chebyshev are commonly used practical filters. The key characteristic of Butterworth filter is that it has a flat passband and stopband. The practical limit for most RC active filters is close to 30 kHz. The Chebyshev response is referred to as an equiripple response because passband is characterised by a series of ripples that have equal maximum levels and equal minimum levels besides exhibiting flat stopband.

Which of the following statements is NOT correct about Butterworth filter?

[Question ID = 805][Question Description = S2_qSNz_PG_ETS_Q97]

1. Butterworth is the most popular alignment type.

[Option ID = 3217]

2. Butterworth is characterised by its moderate amplitude and phase response.

[Option ID = 3218]

3. It exhibits the slowest roll-off of any monoatomic (single-slope) filter.

[Option ID = 3219]

4. This is the only filter whose 3dB down frequency equals its critical frequency ($f_{3dB}=f_c$).

[Option ID = 3220]

Correct Answer :-

- Butterworth is the most popular alignment type.

[Option ID = 3217]

3) Read the passage given below and answer the question

One very common use of filters is bandwidth limiting. Analog filter implementation consists of two categories: passive and active. The active filters are further classified as high-pass, low-pass, band-pass, band-reject and all-pass. Butterworth and

Chebyshev are commonly used practical filters. The key characteristic of Butterworth filter is that it has a flat passband and stopband. The practical limit for most RC active filters is close to 30 kHz. The Chebyshev response is referred to as an equiripple response because passband is characterised by a series of ripples that have equal maximum levels and equal minimum levels besides exhibiting flat stopband.

A filter is needed to remove induced 60 Hz hum from a transducer signal. The rejection bandwidth is 2 Hz. The correct combination of R_{damping} and C values for this filter are:

[Question ID = 806][Question Description = S2_qSNz_PG_ETS_Q98]

1. 30 Ω , 32.5 milli Farads

[Option ID = 3221]

2. 68 Ω , 30.5 milli Farads

[Option ID = 3222]

3. 82 Ω , 3.25 milli Farads

[Option ID = 3223]

4. 89 Ω , 2.65 milli Farads

[Option ID = 3224]

Correct Answer :-

• 30 Ω , 32.5 milli Farads

[Option ID = 3221]

4) Read the passage given below and answer the questions that follow

One very common use of filters is bandwidth limiting. Analog filter implementation consists of two categories: passive and active. The active filters are further classified as high-pass, low-pass, band-pass, band-reject and all-pass. Butterworth and Chebyshev are commonly used practical filters. The key characteristic of Butterworth filter is that it has a flat passband and stopband. The practical limit for most RC active filters is close to 30 kHz. The Chebyshev response is referred to as an equiripple response because passband is characterised by a series of ripples that have equal maximum levels and equal minimum levels besides exhibiting flat stopband.

The characteristic equation for the output voltage of an All-pass filter is given by:

[Question ID = 807][Question Description = S2_qSNz_PG_ETS_Q99]

1. $V_o = V_{in} \left(1 + \frac{2}{j2\pi fRC} \right)$

[Option ID = 3225]

2. $V_o = V_{in} \left(-1 + \frac{2}{j2\pi fRC} \right)$

[Option ID = 3226]

3. $V_o = V_{in} \left(-1 + \frac{2}{j2\pi fRC + 1} \right)$

[Option ID = 3227]

4. $V_o = V_{in} \left(1 + \frac{2}{j2\pi fRC + 1} \right)$

[Option ID = 3228]

Correct Answer :-

• $V_o = V_{in} \left(1 + \frac{2}{j2\pi fRC} \right)$

[Option ID = 3225]

5) Read the passage given below and answer the questions that follow

One very common use of filters is bandwidth limiting. Analog filter implementation consists of two categories: passive and active. The active filters are further classified as high-pass, low-pass, band-pass, band-reject and all-pass. Butterworth and Chebyshev are commonly used practical filters. The key characteristic of Butterworth filter is that it has a flat passband and stopband. The practical limit for most RC active filters is close to 30 kHz. The Chebyshev response is referred to as an equiripple response because passband is characterised by a series of ripples that have equal maximum levels and equal minimum levels besides exhibiting flat stopband.

Which of the following statements are correct for active filters?

A. Multiple feedback are preferred for $Q \leq 10$.

B. For $Q > 10$, state variable filter is used.

(3) 25.8%

(4) 24.6%

[Question ID = 2639][Question Description = Q1_GP_SET8_S1_Shift2]

1. 1 [Option ID = 10553]
2. 2 [Option ID = 10554]
3. 3 [Option ID = 10555]
4. 4 [Option ID = 10556]

Correct Answer :-

- 1 [Option ID = 10553]

- 2) The table below presents the unit sales of the 'ZZ999' Motorcycle in six European Countries over a six month period from January – 2020 to June 2020. These motorcycles are imported into each country by a main dealer. Based on the data in the table, answer the question :

Country – wise Sale of Motorcycles

Country	January	February	March	April	May	June	Total
Germany	34	47	45	54	56	60	
UK	40	44	36	47	47	46	
France	37	32	32	32	34	33	
Belgium	14	14	14	16	17	14	
Spain	29	29	28	31	29	31	
Italy	22	24	24	26	25	23	
Total							

What percentage (%) of the overall total of motorcycles was sold in May?

- (1) 24.1% (2) 25.6%
 (3) 27.1% (4) 17.8%

निम्नलिखित सारणी जनवरी 2020 से जून 2020 तक की छह माह की अवधि में छह यूरोपीय देशों द्वारा 'ZZ999' मोटर साइकिल की एकक बिक्री (यूनिट सेल) को दर्शाती है। ये मोटरसाइकिलें किसी मुख्य विक्रेता (डीलर) के द्वारा प्रत्येक देश में आयातित की जाती हैं। सारणी में प्रस्तुत आँकड़ों के आधार पर प्रश्न का उत्तर दीजिए:

देश-वार मोटरसाइकिलों की बिक्री

देश	जनवरी	फरवरी	मार्च	अप्रैल	मई	जून	कुल
जर्मनी	34	47	45	54	56	60	
यू के	40	44	36	47	47	46	
फ्रांस	37	32	32	32	34	33	
बेल्जियम	14	14	14	16	17	14	
स्पेन	29	29	28	31	29	31	
इटली	22	24	24	26	25	23	
कुल							

मई माह में बेची गई कुल योग का प्रतिशत क्या है?

- (1) 24.1% (2) 25.6%
 (3) 27.1% (4) 17.8%

[Question ID = 2640][Question Description = Q2_GP_SET8_S1_Shift2]

1. 1 [Option ID = 10557]
2. 2 [Option ID = 10558]
3. 3 [Option ID = 10559]
4. 4 [Option ID = 10560]

Correct Answer :-

- 1 [Option ID = 10557]

- 3) The table below presents the unit sales of the 'ZZ999' Motorcycle in six European Countries over a six month period from January – 2020 to June 2020. These motorcycles are imported

into each country by a main dealer. Based on the data in the table, answer the question :

Country – wise Sale of Motorcycles

Country	January	February	March	April	May	June	Total
Germany	34	47	45	54	56	60	
UK	40	44	36	47	47	46	
France	37	32	32	32	34	33	
Belgium	14	14	14	16	17	14	
Spain	29	29	28	31	29	31	
Italy	22	24	24	26	25	23	
Total							

Which month showed the biggest increase in total sales from the previous month?

- (1) February (2) March
(3) April (4) May

निम्नलिखित सारणी जनवरी 2020 से जून 2020 तक की छह माह की अवधि में छह यूरोपीय देशों द्वारा 'ZZ999' मोटर साइकिल की एकक बिक्री (यूनिट सेल) को दर्शाती है। ये मोटरसाइकिलें किसी मुख्य विक्रेता (डीलर) के द्वारा प्रत्येक देश में आयातित की जाती हैं। सारणी में प्रस्तुत आँकड़ों के आधार पर प्रश्न का उत्तर दीजिए:

देश-वार मोटरसाइकिलों की बिक्री

देश	जनवरी	फरवरी	मार्च	अप्रैल	मई	जून	कुल
जर्मनी	34	47	45	54	56	60	
यू के	40	44	36	47	47	46	
फ्रांस	37	32	32	32	34	33	
बेल्जियम	14	14	14	16	17	14	
स्पेन	29	29	28	31	29	31	
इटली	22	24	24	26	25	23	
कुल							

किस माह की बिक्री पिछली माह की बिक्री की तुलना में सर्वाधिक वृद्धि दर्शाती है?

- (1) फरवरी (2) मार्च
(3) अप्रैल (4) मई

[Question ID = 2641][Question Description = Q3_GP_SET8_S1_Shift2]

- 1 [Option ID = 10561]
- 2 [Option ID = 10562]
- 3 [Option ID = 10563]
- 4 [Option ID = 10564]

Correct Answer :-

- 1 [Option ID = 10561]

- 4) The table below presents the unit sales of the 'ZZ999' Motorcycle in six European Countries over a six month period from January – 2020 to June 2020. These motorcycles are imported into each country by a main dealer. Based on the data in the table, answer the question :

Country – wise Sale of Motorcycles

Country	January	February	March	April	May	June	Total
Germany	34	47	45	54	56	60	
UK	40	44	36	47	47	46	
France	37	32	32	32	34	33	
Belgium	14	14	14	16	17	14	
Spain	29	29	28	31	29	31	
Italy	22	24	24	26	25	23	
Total							

In the month of February, what percentage (%) of the monthly total was sold to the biggest importer?

- (1) 24.7% (2) 23.1%
(3) 36.5% (4) 51.1%

निम्नलिखित सारणी जनवरी 2020 से जून 2020 तक की छह माह की अवधि में छह यूरोपीय देशों द्वारा 'ZZ999' मोटर साइकिल की एकक बिक्री (यूनिट सेल) को दर्शाती है। ये मोटरसाइकिलें किसी मुख्य विक्रेता (डीलर) के द्वारा प्रत्येक देश में आयातित की जाती हैं। सारणी में प्रस्तुत आँकड़ों के आधार पर प्रश्न का उत्तर दीजिए:

देश-वार मोटरसाइकिलों की बिक्री

देश	जनवरी	फरवरी	मार्च	अप्रैल	मई	जून	कुल
जर्मनी	34	47	45	54	56	60	
यू के	40	44	36	47	47	46	
फ्रांस	37	32	32	32	34	33	
बेल्जियम	14	14	14	16	17	14	
स्पेन	29	29	28	31	29	31	
इटली	22	24	24	26	25	23	
कुल							

फरवरी माह में सबसे बड़े आयातकर्ता को कुल मासिक मोटरसाइकिलों का कितना प्रतिशत बेचा गया?

- (1) 24.7% (2) 23.1%
(3) 36.5% (4) 51.1%

[Question ID = 2642][Question Description = Q4_GP_SET8_S1_Shift2]

- 1 [Option ID = 10565]
- 2 [Option ID = 10566]
- 3 [Option ID = 10567]
- 4 [Option ID = 10568]

Correct Answer :-

- 1 [Option ID = 10565]

- 5) The table below presents the unit sales of the 'ZZ999' Motorcycle in six European Countries over a six month period from January – 2020 to June 2020. These motorcycles are imported into each country by a main dealer. Based on the data in the table, answer the question :

Country – wise Sale of Motorcycles

Country	January	February	March	April	May	June	Total
Germany	34	47	45	54	56	60	
UK	40	44	36	47	47	46	
France	37	32	32	32	34	33	
Belgium	14	14	14	16	17	14	
Spain	29	29	28	31	29	31	
Italy	22	24	24	26	25	23	
Total							

What percentage (%) of the total imports is accounted for by the three smallest importers?

- (1) 37.1% (2) 14.8%
(3) 40.0% (4) 35.2%

निम्नलिखित सारणी जनवरी 2020 से जून 2020 तक की छह माह की अवधि में छह यूरोपीय देशों द्वारा 'ZZ999' मोटर साइकिल की एकक बिक्री (यूनिट सेल) को दर्शाती है। ये मोटरसाइकिलें किसी मुख्य विक्रेता (डीलर) के द्वारा प्रत्येक देश में आयातित की जाती हैं। सारणी में प्रस्तुत आँकड़ों के आधार पर प्रश्न का उत्तर दीजिए:

देश-वार मोटरसाइकिलों की बिक्री

देश	जनवरी	फरवरी	मार्च	अप्रैल	मई	जून	कुल
जर्मनी	34	47	45	54	56	60	
यू के	40	44	36	47	47	46	
फ्रांस	37	32	32	32	34	33	
बेल्जियम	14	14	14	16	17	14	
स्पेन	29	29	28	31	29	31	
इटली	22	24	24	26	25	23	
कुल							

तीन सबसे छोटे आयातकर्ताओं द्वारा कुल आयात का कितना प्रतिशत आयात किया गया है ?

- (1) 37.1% (2) 14.8%
(3) 40.0% (4) 35.2%

[Question ID = 2643][Question Description = Q5_GP_SET8_S1_Shift2]

- 1 [Option ID = 10569]
- 2 [Option ID = 10570]
- 3 [Option ID = 10571]
- 4 [Option ID = 10572]

Correct Answer :-

- 1 [Option ID = 10569]

Topic:- GP_Set8_B

1) What is the name for the type of checklist or rating scale that expresses criteria on some point-scale to determine the quality of the performance of a student?

- (1) Diffusion (2) Rubrics
(3) Track system (4) Deduction

एक विद्यार्थी के गुणवत्ता निर्धारण के लिए मानदण्डों को दर्शाने वाली चिह्नकन सूची या निर्धारण का क्या नाम है ?

- (1) विसरण (2) रूब्रिक
(3) ट्रैक-सिस्टम (4) निगमन

[Question ID = 2684][Question Description = Q06_GP_Set8_S1_Shift2]

- 1 [Option ID = 10733]
- 2 [Option ID = 10734]
- 3 [Option ID = 10735]
- 4 [Option ID = 10736]

Correct Answer :-

- 1 [Option ID = 10733]

2) What is the name of the mental process that assists learners to reflect on their thinking by internalizing, understanding, and recalling the content to be learned?

- (1) Meta cognition (2) Rubrics
(3) Peer tutoring (4) Debriefing

उस मानसिक प्रक्रिया का नाम क्या है जो आभ्यन्तरीकरण, ग्रहणशक्ति, अधिगमित की जाने वाली विषय-वस्तु के प्रत्याह्वान के द्वारा शिक्षार्थी को उनके चिन्तन विमर्श पर सहायता करती है ?

- (1) अधिसंज्ञान (2) रूब्रिक
(3) समकक्षी अनुशिक्षण (4) संक्षिप्त जानकारी लेना

[Question ID = 2685][Question Description = Q07_GP_Set8_S1_Shift2]

- 1 [Option ID = 10737]
- 2 [Option ID = 10738]
- 3 [Option ID = 10739]
- 4 [Option ID = 10740]

Correct Answer :-

- 1 [Option ID = 10737]

3) Given below are two statements :

Statement I : In free version of google meet (through your personal Gmail / Google account) you can record your session / class.

Statement II : To join an online class / session conducted via Google Meet you need to login to your Google account.

In the light of the above statements, choose the correct answer from the options given below:

- (1) Both Statement I and Statement II are correct
- (2) Both Statement I and Statement II are incorrect
- (3) Statement I is correct but Statement II is incorrect
- (4) Statement I is incorrect but Statement II is correct

नीचे दो कथन दिए गए हैं :

कथन (I) : गूगल मीट के फ्री वर्जन में (अपने व्यक्तिगत जी मेल/गूगल एकाउंट के द्वारा आप अपना सत्र रिकार्ड कर सकते हैं।

कथन (II) : गूगल मीट द्वारा संचालित एक ऑनलाइन कक्षा/सत्र को ज्वाइन करने के लिए आपको अपने गूगल एकाउंट में लॉग-इन करने की जरूरत पड़ती है।

उपरोक्त कथन के आलोक में, नीचे दिए गए विकल्पों में से सबसे उपयुक्त उत्तर का चयन कीजिए :

- (1) कथन I और II दोनों सही हैं।
- (2) कथन I और II दोनों गलत हैं।
- (3) कथन I सही है, लेकिन कथन II गलत है।
- (4) कथन I गलत है, लेकिन कथन II सही है।

[Question ID = 2686][Question Description = Q08_GP_Set8_S1_Shift2]

1. 1 [Option ID = 10741]
2. 2 [Option ID = 10742]
3. 3 [Option ID = 10743]
4. 4 [Option ID = 10744]

Correct Answer :-

- 1 [Option ID = 10741]

4) Which of these decision traps pertain to personal qualities?

- (A) Frame blindness
- (B) Overconfidence
- (C) Taking shortcuts
- (D) Being unsystematic
- (E) Not keeping records

Choose the correct answer from the options given below :

- (1) (A), (B), (C) only
- (2) (B), (C), (D) only
- (3) (A), (C), (D) only
- (4) (C), (D), (E) only

निम्नलिखित में से कौन निर्णय-पाश वैयक्तिक गुणों से सम्बन्धित हैं?

- (A) अन्ध-विन्यास
- (B) अति-निष्ठा

- (C) संक्षिप्त मार्गानुसरण
- (D) अव्यवस्थित होना
- (E) रिकॉर्ड नहीं रखना

नीचे दिए गए विकल्पों में से सही उत्तर का चयन कीजिए :

- (1) केवल (A), (B), (C) (2) केवल (B), (C), (D)
- (3) केवल (A), (C), (D) (4) केवल (C), (D), (E)

[Question ID = 2687][Question Description = Q09_GP_Set8_S1_Shift2]

1. 1 [Option ID = 10745]
2. 2 [Option ID = 10746]
3. 3 [Option ID = 10747]
4. 4 [Option ID = 10748]

Correct Answer :-

- 1 [Option ID = 10745]

5) Match List I with List II

List I	List II
(A) Proprietary LMS	(I) MOODLE
(B) Open source LMS	(II) Google classroom
(C) Cloud based LMS	(III) Black board
(D) Data collection and quiz	(IV) Google form

Choose the correct answer from the options given below :

- (1) (A)-(IV), (B)-(III), (C)-(I), (D)-(II)
- (2) (A)-(II), (B)-(IV), (C)-(III), (D)-(I)
- (3) (A)-(I), (B)-(II), (C)-(IV), (D)-(III)
- (4) (A)-(III), (B)-(I), (C)-(II), (D)-(IV)

सूची-I के साथ सूची-II का मिलान कीजिए :

सूची-I	सूची-II
(A) प्रोप्राएटरी एल.एम.एस.	(I) एम.ओ.ओ.डी.एल.ई. (मूडल)
(B) ओपेन सोर्स एल.एम.एस.	(II) गूगल क्लासरूम
(C) क्लाउड बेस्ड एल.एम.एस.	(III) ब्लैक बोर्ड
(D) डेटा संकलन और क्विज	(IV) गूगल फॉर्म

नीचे दिये गए विकल्पों में से सही उत्तर का चयन कीजिए :

- (1) (A)-(IV), (B)-(III), (C)-(I), (D)-(II)
- (2) (A)-(II), (B)-(IV), (C)-(III), (D)-(I)
- (3) (A)-(I), (B)-(II), (C)-(IV), (D)-(III)
- (4) (A)-(III), (B)-(I), (C)-(II), (D)-(IV)

[Question ID = 2688][Question Description = Q10_GP_Set8_S1_Shift2]

1. 1 [Option ID = 10749]
2. 2 [Option ID = 10750]
3. 3 [Option ID = 10751]
4. 4 [Option ID = 10752]

Correct Answer :-

• 1 [Option ID = 10749]

6) Scientific research has the ultimate goal of explaining any phenomenon by

- | | |
|-----------------------|----------------------------|
| (1) Conditional laws | (2) Laws of uniqueness |
| (3) Laws of intuition | (4) Laws of generalisation |

वैज्ञानिक शोध के पास किसी परिघटना के कारण बताने का अन्तिम लक्ष्य, किसके माध्यम से होता है?

- | | |
|---------------------------|-------------------------|
| (1) गोपनीय नियम | (2) अद्वितीयता का नियम |
| (3) अन्तः प्रज्ञा का नियम | (4) सामान्यीकरण का नियम |

[Question ID = 2689][Question Description = Q11_GP_Set8_S1_Shift2]

1. 1 [Option ID = 10753]
2. 2 [Option ID = 10754]
3. 3 [Option ID = 10755]
4. 4 [Option ID = 10756]

Correct Answer :-

• 1 [Option ID = 10753]

7) Which of the following are true case studies?

- (A) Easy to generalize the findings
- (B) Normally Selects one case for analysis at a time
- (C) Highly quantitative in character
- (D) Integrates different perspectives
- (E) Adopts the most consequent approach to the particular

Choose the correct answer from the options given below :

- | | |
|------------------------|------------------------|
| (1) (A), (B), (C) only | (2) (B), (C), (D) only |
| (3) (B), (D), (E) only | (4) (C), (D), (E) only |

निम्नलिखित में से कौन प्रकरण-अध्ययन के बारे में सत्य हैं?

- (A) प्राप्ति का सामान्यीकरण आसान है
- (B) सामान्यतया एक समय में एक प्रकरण का चयन करता है।
- (C) विशेषता में उच्च परिमाण वाला।
- (D) विभिन्न परिप्रेक्ष्यों को संघटित करता है।
- (E) विविध हेतु सर्वोत्कृष्ट अनुवर्ती उपागम को अंगीकार करता है।

नीचे दिए गए विकल्पों में से सही उत्तर का चयन कीजिए :

- | | |
|------------------------|------------------------|
| (1) केवल (A), (B), (C) | (2) केवल (B), (C), (D) |
| (3) केवल (B), (D), (E) | (4) केवल (C), (D), (E) |

[Question ID = 2690][Question Description = Q12_GP_Set8_S1_Shift2]

1. 1 [Option ID = 10757]
2. 2 [Option ID = 10758]
3. 3 [Option ID = 10759]
4. 4 [Option ID = 10760]

Correct Answer :-

- 1 [Option ID = 10757]

8) Identify the sequence of methodological steps in focus group research :

- (A) Select a sample
- (B) Prepare the focus group material
- (C) Define the problem
- (D) Decide the number of groups needed
- (E) Prepare the mechanics of the study

Choose the correct answer from the options given below :

- | | |
|-----------------------------|-----------------------------|
| (1) (A), (E), (D), (C), (B) | (2) (C), (A), (D), (E), (B) |
| (3) (B), (C), (A), (D), (E) | (4) (D), (A), (C), (B), (E) |

संकेन्द्रित समूह शोध में क्रमकद्ध चरण की श्रृंखला की पहचान करें :

- (A) एक प्रतिदर्श चुनें।
- (B) संकेन्द्रित समूह उपादान तैयार करें।
- (C) समस्या को परिभाषित करें।
- (D) आवश्यक समूह संख्या का निर्णय लें।
- (E) अध्ययन प्रणाली तैयार करें।

नीचे दिए गए विकल्पों में से सही उत्तर का चयन कीजिए :

- | | |
|-----------------------------|-----------------------------|
| (1) (A), (E), (D), (C), (B) | (2) (C), (A), (D), (E), (B) |
| (3) (B), (C), (A), (D), (E) | (4) (D), (A), (C), (B), (E) |

[Question ID = 2691][Question Description = Q13_GP_Set8_S1_Shift2]

1. 1 [Option ID = 10761]
2. 2 [Option ID = 10762]
3. 3 [Option ID = 10763]
4. 4 [Option ID = 10764]

Correct Answer :-

- 1 [Option ID = 10761]

9) Given below are two statements :

Statement I: Social scientists believe that the quantitative tradition does not accept the idea of

Statement I : Social sciences struggling to the reductionist tradition do not accept the idea of predicting human behavior in mechanistic terms.

Statement II : It is asserted that the main aim of social science research is to promote human understanding.

In the light of the above statements, choose the correct answer from the options given below:

- (1) Both Statement I and Statement II are true
- (2) Both Statement I and Statement II are false
- (3) Statement I is true but Statement II is false
- (4) Statement I is false but Statement II is true

नीचे दो कथन दिए गए हैं :

कथन (I) : वेस्तेहन रीति से सम्बद्ध सामाजिक वैज्ञानिक यन्त्रवादी पदों में मानव व्यवहार भविष्यवाणी के विचार को स्वीकार नहीं करते हैं।

कथन (II) : यह निश्चयपूर्वक कहा जाता है कि सामाजिक विज्ञान शोध उद्देश्य मानव बोध को प्रोत्साहित करता है।

उपरोक्त कथन के आलोक में, नीचे दिए गए विकल्पों में से सही उत्तर का चयन कीजिए :

- (1) कथन I और II दोनों सत्य हैं।
- (2) कथन I और II दोनों असत्य हैं।
- (3) कथन I सत्य है, लेकिन कथन II असत्य है।
- (4) कथन I असत्य है, लेकिन कथन II सत्य है।

[Question ID = 2692][Question Description = Q14_GP_Set8_S1_Shift2]

1. 1 [Option ID = 10765]
2. 2 [Option ID = 10766]
3. 3 [Option ID = 10767]
4. 4 [Option ID = 10768]

Correct Answer :-

- 1 [Option ID = 10765]

10) Match List I with List II

List I Concept	List II Description
(A) Isomorphism	(I) Use of both qualitative and quantitative methods
(B) Triangulation	(II) Premise that the simplest method is most preferable
(C) Principle of Parsimony	(III) A property of a population
(D) Parameter	(IV) Similarity of structure

Choose the correct answer from the options given below :

- (1) (A)-(I), (B)-(II), (C)-(III), (D)-(IV)
- (2) (A)-(II), (B)-(III), (C)-(IV), (D)-(I)

(3) (A)-(III), (B)-(IV), (C)-(I), (D)-(II)

(4) (A)-(IV), (B)-(I), (C)-(II), (D)-(III)

सूची-I के साथ सूची-II का मिलान कीजिए :

सूची-I संकल्पना	सूची-II विवरण
(A) समाकृतिकता	(I) गुणात्मक और परिणामात्मक दोनों पद्धतियों का प्रयोग
(B) त्रिभुजन	(II) आधार वाक्य कि सरलतम पद्धति सर्वाधिक वरीय है
(C) कृपणता का सिद्धान्त	(III) जनसंख्या का गुण
(D) प्राचल	(IV) संरचना की समानता

नीचे दिये गए विकल्पों में से सही उत्तर का चयन कीजिए :

(1) (A)-(I), (B)-(II), (C)-(III), (D)-(IV)

(2) (A)-(II), (B)-(III), (C)-(IV), (D)-(I)

(3) (A)-(III), (B)-(IV), (C)-(I), (D)-(II)

(4) (A)-(IV), (B)-(I), (C)-(II), (D)-(III)

[Question ID = 2693][Question Description = Q15_GP_Set8_S1_Shift2]

1. 1 [Option ID = 10769]
2. 2 [Option ID = 10770]
3. 3 [Option ID = 10771]
4. 4 [Option ID = 10772]

Correct Answer :-

- 1 [Option ID = 10769]

11) In a classroom, transforming verbal and non-verbal signs back into messages is known as

(1) Feedback

(2) Encoding

(3) Decoding

(4) Reverse communication

कक्षा में भाषिक (वर्बल) संकेत तथा अभाषिक (नान-वर्बल) संकेतों का संदेश में रूपांतरण कहलाता है

(1) प्रतिपुष्टि (फीडबैक)

(2) संकेतन (इन्कोडिंग)

(3) विसंकेतन (डिकोडिंग)

(4) विपरीत संप्रेषण (रिवर्स कम्यूनिकेशन)

[Question ID = 2694][Question Description = Q16_GP_Set8_S1_Shift2]

1. 1 [Option ID = 10773]
2. 2 [Option ID = 10774]
3. 3 [Option ID = 10775]
4. 4 [Option ID = 10776]

Correct Answer :-

- 1 [Option ID = 10773]

12) Perspective taking in communication supports

(A) Behavioural rigidity

(B) Openness

(C) Sharing of information

(D) Trust

(E) Secrecy

Choose the correct answer from the options given below :

(1) (A), (B), and (C) only

(2) (B), (C), and (D) only

(3) (C), (D), and (E) only

(4) (A), (C), and (E) only

संप्रेषण में परिप्रेक्ष्य ग्रहण निम्नलिखित में से किसकी सहायता करता है?

- (A) व्यवहारपरक अनध्यता
- (B) खुलापन
- (C) सूचना की साझेदारी
- (D) विश्वास
- (E) गोपनीयता

नीचे दिए गए विकल्पों में से सही उत्तर का चयन कीजिए :

- (1) केवल (A), (B) और (C)
- (2) केवल (B), (C) और (D)
- (3) केवल (C), (D) और (E)
- (4) केवल (A), (C) और (E)

[Question ID = 2695][Question Description = Q17_GP_Set8_S1_Shift2]

- 1. 1 [Option ID = 10777]
- 2. 2 [Option ID = 10778]
- 3. 3 [Option ID = 10779]
- 4. 4 [Option ID = 10780]

Correct Answer :-

- 1 [Option ID = 10777]

13)

Given below are two statements : One is labelled as Assertion (A) and the other is labelled as Reason (R) :

Assertion (A) : The positive feedback from the teacher is necessary to motivate students.

Reasons (R) : Continuous criticism of students is the best method to make them realize positive outcomes in their pursuit of knowledge.

In the light of the above statements, choose the answer from the options given below :

- (1) Both (A) and (R) are true and (R) is the correct explanation of (A)
- (2) Both (A) and (R) are true but (R) is NOT the correct explanation of (A)
- (3) (A) is true but (R) is false
- (4) (A) is false but (R) is true

नीचे दो कथन दिए गए हैं : एक अभिकथन (Assertion A) के रूप में लिखित है तो दूसरा उसके कारण (Reason R) के रूप में

अभिकथन (A) : शिक्षकों से सकारात्मक प्रतिपुष्टि (पॉजिटिव फीडबैक) विद्यार्थियों को अभिप्रेरित करने के लिए अनिवार्य होती है।

कारण (R) : विद्यार्थियों की लगातार आलोचना उनके ज्ञान की इच्छा में सकारात्मक परिणाम को महसूस कराने की सर्वोत्तम विधि है।

- (1) (A) और (R) दोनों सही हैं और (R), (A) की सही व्याख्या है।
- (2) (A) और (R) दोनों सत्य हैं लेकिन (R), (A) की सही व्याख्या नहीं है।
- (3) (A) सत्य है लेकिन (R) असत्य है।
- (4) (A) असत्य है लेकिन (R) सत्य है।

[Question ID = 2696][Question Description = Q18_GP_Set8_S1_Shift2]

1. 1 [Option ID = 10781]
2. 2 [Option ID = 10782]
3. 3 [Option ID = 10783]
4. 4 [Option ID = 10784]

Correct Answer :-

- 1 [Option ID = 10781]

14) The sequence of the stages of communication process is :

- (A) Level of acceptance
- (B) Transmission of cognitive data
- (C) Message reception
- (D) Understanding
- (E) Reaction

Choose the correct answer from the options given below :

- | | |
|-----------------------------|-----------------------------|
| (1) (A), (B), (C), (D), (E) | (2) (B), (C), (D), (E), (A) |
| (3) (C), (E), (D), (A), (B) | (4) (B), (C), (D), (A), (E) |

संप्रेषण प्रक्रिया में चरणों का अनुक्रम है:

- (A) प्रतिग्रहण (एक्सेप्टेंस) का स्तर
- (B) संज्ञानात्मक (कॉग्निटिव) आँकड़ों का संचरण
- (C) संदेश ग्रहण (मेसेज रिसेप्शन)
- (D) बोध (अण्डरस्टैंडिंग)
- (E) प्रतिक्रिया

नीचे दिए गए विकल्पों में से सही उत्तर का चयन कीजिए :

- | | |
|-----------------------------|-----------------------------|
| (1) (A), (B), (C), (D), (E) | (2) (B), (C), (D), (E), (A) |
| (3) (C), (E), (D), (A), (B) | (4) (B), (C), (D), (A), (E) |

[Question ID = 2697][Question Description = Q19_GP_Set8_S1_Shift2]

1. 1 [Option ID = 10785]

2. 2 [Option ID = 10786]
3. 3 [Option ID = 10787]
4. 4 [Option ID = 10788]

Correct Answer :-

- 1 [Option ID = 10785]

15) Match List I with List II

List I	List II
Type of communication	Characteristic feature
(A) Network communication	(I) Formal and Planned
(B) Mass communication	(II) Creates identity and unique dynamics
(C) Public communication	(III) Inter – dependent relations
(D) Small group communication	(IV) Anonymous audience

Choose the correct answer from the options given below :

- (1) (A)-(II), (B)-(III), (C)-(IV), (D)-(I)
- (2) (A)-(III), (B)-(IV), (C)-(I), (D)-(II)
- (3) (A)-(IV), (B)-(I), (C)-(II), (D)-(III)
- (4) (A)-(I), (B)-(II), (C)-(III), (D)-(IV)

सूची-I के साथ सूची-II का मिलान कीजिए :

सूची-I	सूची-II
संप्रेषण के प्रकार	विशेषताएं
(A) नेटवर्क संचार	(I) औपचारिक तथा योजनाबद्ध
(B) जन संचार (मास कम्यूनिकेशन)	(II) यह अनन्यता (आइडेन्टिटी) तथा अद्वितीय गतिकी (यूनिक डायनामिक्स) का निर्माण करता है।
(C) सार्वजनिक संचार (पब्लिक कम्यूनिकेशन)	(III) अन्योन्याश्रित संबंध (इन्टर डिपेन्डेन्ट रिलेशन्स)
(D) लघु समूह संचार	(IV) असात श्रोता (अनॉनिमस ऑडिएन्स)

नीचे दिये गए विकल्पों में से सही उत्तर का चयन कीजिए :

- (1) (A)-(II), (B)-(III), (C)-(IV), (D)-(I)
- (2) (A)-(III), (B)-(IV), (C)-(I), (D)-(II)
- (3) (A)-(IV), (B)-(I), (C)-(II), (D)-(III)
- (4) (A)-(I), (B)-(II), (C)-(III), (D)-(IV)

[Question ID = 2698][Question Description = Q20_GP_Set8_S1_Shift2]

1. 1 [Option ID = 10789]
2. 2 [Option ID = 10790]
3. 3 [Option ID = 10791]
4. 4 [Option ID = 10792]

Correct Answer :-

- 1 [Option ID = 10789]

16)

Sagun purchased a smartphone at $9/10^{\text{th}}$ of its selling price and sold it at 8% more than its selling price. Her gain is

- | | |
|---------|---------|
| (1) 10% | (2) 12% |
| (3) 18% | (4) 20% |

सगुन ने एक स्मार्ट फोन इसके बिक्रय मूल्य के 9/10वें मूल्य पर खरीदा तथा इसे इसके बिक्रय मूल्य से 8% अधिक पर बेचा।
उसका लाभ है

- (1) 10% (2) 12%
(3) 18% (4) 20%

[Question ID = 2699][Question Description = Q21_GP_Set8_S1_Shift2]

1. 1 [Option ID = 10793]
2. 2 [Option ID = 10794]
3. 3 [Option ID = 10795]
4. 4 [Option ID = 10796]

Correct Answer :-

- 1 [Option ID = 10793]

17) If CHARCOAL is coded as 45164913, how will you code COALCAR?

- (1) 4913413 (2) 6194314
(3) 3194416 (4) 4913416

यदि कूट भाषा में CHARCOAL को 45164913 लिखा जाए, तो COALCAR को किस प्रकार लिखा जाएगा?

- (1) 4913413 (2) 6194314
(3) 3194416 (4) 4913416

[Question ID = 2700][Question Description = Q22_GP_Set8_S1_Shift2]

1. 1 [Option ID = 10797]
2. 2 [Option ID = 10798]
3. 3 [Option ID = 10799]
4. 4 [Option ID = 10800]

Correct Answer :-

- 1 [Option ID = 10797]

18) Looking at a photo of a man, Ravi said, 'His mother is the wife of my Father's son. I have no brothers and sisters'.
At whose photo was Ravi looking?

- (1) His Cousin (2) His Son
(3) His Uncle (4) His nephew

किसी पुरुष के फोटो की तरफ देखकर रवि ने कहा, "उसकी माँ मेरे पिता के पुत्र की पत्नी है। मेरा कोई भाई या बहन नहीं है।" रवि किसके फोटो की तरफ देख रहा था?

- (1) अपने चचेरे भाई/बहन (कजन) (2) अपने पुत्र
(3) अपने चाचा (4) अपने भतीजा

[Question ID = 2701][Question Description = Q23_GP_Set8_S1_Shift2]

1. 1 [Option ID = 10801]
2. 2 [Option ID = 10802]
3. 3 [Option ID = 10803]
4. 4 [Option ID = 10804]

Correct Answer :-

- 1 [Option ID = 10801]

19) Given below are two statements :

Statement I: If the interest on a sum borrowed for a certain period is reckoned uniformly, then it is called compound interest.

Statement II : The money borrowed or lent out for a certain period is called simple interest.

In the light of the above statements, choose the correct answer from the options given below:

- (1) Both Statement I and Statement II are true
- (2) Both Statement I and Statement II are false
- (3) Statement I is true but Statement II is false
- (4) Statement I is false but Statement II is true

नीचे दो कथन दिए गए हैं :

कथन (I) : यदि किसी अवधि के लिए गये ऋण पर ब्याज की गणना एक समान की जाती है, तो वह ब्याज चक्रवृद्धि ब्याज कहलाता है।

कथन (II) : किसी अवधि के लिए ऋण ली गई अथवा ऋण दी गई धनराशि सामान्य ब्याज कहलाती है।

उपरोक्त कथन के आलोक में, नीचे दिए गए विकल्पों में से सही उत्तर का चयन कीजिए :

- (1) कथन I और II दोनों सत्य हैं।
- (2) कथन I और II दोनों असत्य हैं।
- (3) कथन I सत्य है, लेकिन कथन II असत्य है।
- (4) कथन I असत्य है, लेकिन कथन II सत्य है।

[Question ID = 2702][Question Description = Q24_GP_Set8_S1_Shift2]

1. 1 [Option ID = 10805]
2. 2 [Option ID = 10806]
3. 3 [Option ID = 10807]
4. 4 [Option ID = 10808]

Correct Answer :-

- 1 [Option ID = 10805]

20) Match List I with List II With respect to completion of sentences

List I	List II
(A) The sum of first forty five natural number is	(I) 19
(B) The least prime number is	(II) 75
(C) The total number of prime numbers less than 70 is	(III) 1035
(D) On dividing 4150 by a certain number the quotient is 55 and the remainder is 25. The divisor is	(IV) 2

Choose the correct answer from the options given below :

- (1) (A)-(II), (B)-(III), (C)-(I), (D)-(IV)
- (2) (A)-(III), (B)-(II), (C)-(IV), (D)-(I)
- (3) (A)-(III), (B)-(IV), (C)-(I), (D)-(II)
- (4) (A)-(II), (B)-(IV), (C)-(III), (D)-(I)

सूची-I के साथ सूची-II का मिलान कीजिए इस प्रकार कीजिए कि वाक्य पूरा हो जाए।

सूची-I	सूची-II
(A) प्रथम पैंतालीस प्राकृतिक संख्याओं का योग है	(I) 19
(B) सबसे छोटी रूढ़ संख्या है।	(II) 75
(C) सत्तर से छोटी रूढ़ संख्याओं का कुल योग होगा।	(III) 1035
(D) संख्या 4150 को किसी संख्या से भाग देने पर भागफल 55 और शेष 25 होता है, तो भाजक है	(IV) 2

नीचे दिये गए विकल्पों में से सही उत्तर का चयन कीजिए :

- (1) (A)-(II), (B)-(III), (C)-(I), (D)-(IV)
- (2) (A)-(III), (B)-(II), (C)-(IV), (D)-(I)
- (3) (A)-(III), (B)-(IV), (C)-(I), (D)-(II)
- (4) (A)-(II), (B)-(IV), (C)-(III), (D)-(I)

[Question ID = 2703][Question Description = Q25_GP_Set8_S1_Shift2]

1. 1 [Option ID = 10809]
2. 2 [Option ID = 10810]
3. 3 [Option ID = 10811]
4. 4 [Option ID = 10812]

Correct Answer :-

- 1 [Option ID = 10809]

21) Given below are two statements : One is labelled as Assertion (A) and the other is labelled as Reason (R) :

Assertion (A) : The argument "Everything is nameable because it is knowlegable" is fallacious.

Reasons (R) : There is nothing that is not nameable and I cannot find a place where, because of the absence of the major term, the middle term is also absent.

In the light of the above statements, choose the most appropriate answer from the options given below :

- (1) Both (A) and (R) are correct and (R) is the correct explanation of (A)
- (2) Both (A) and (R) are correct and (R) is NOT the correct explanation of (A)
- (3) (A) is correct but (R) is not correct
- (4) (A) is not correct but (R) is correct

नीचे दो कथन दिए गए हैं : एक अभिकथन (Assertion A) के रूप में लिखित है तो दूसरा उसके कारण (Reason R) के रूप में :

अभिकथन (A) : तर्क – "हर वस्तु का नाम हो सकता है क्योंकि वह ज्ञेय (नालिजेबल) है" भ्रामक है।

कारण (R) : ऐसी कोई वस्तु नहीं जिसका नाम नहीं हो सकता और मैं ऐसा कोई स्थान नहीं पाता है, जहां साध्य नहीं है तो हेतु भी नहीं है।

उपरोक्त कथन के आलोक में, नीचे दीए गए विकल्पों में से सबसे उपयुक्त उत्तर का चयन कीजिए :

- (1) (A) और (R) दोनों सही हैं और (R) (A) की सही व्याख्या है।

21) (A) और (R) दोनों सही हैं लेकिन (R), (A) की सही व्याख्या नहीं है।

(2) (A) और (R) दोनों सही हैं लेकिन (R), (A) की सही व्याख्या नहीं है।

(3) (A) सही है लेकिन (R) सही नहीं है।

(4) (A) सही नहीं है लेकिन (R) सही है।

[Question ID = 2704][Question Description = Q26_GP_Set8_S1_Shift2]

1. 1 [Option ID = 10813]
2. 2 [Option ID = 10814]
3. 3 [Option ID = 10815]
4. 4 [Option ID = 10816]

Correct Answer :-

- 1 [Option ID = 10813]

22) Given below are two statements :

Statement I : The terms 'true' and 'false' apply to arguments.

Statement II : The terms 'true' and 'false' apply to statements.

In the light of the above statements, choose the correct answer from the options given below:

- (1) Both Statement I and Statement II are true
- (2) Both Statement I and Statement II are false
- (3) Statement I is true but Statement II is false
- (4) Statement I is false but Statement II is true

नीचे दो कथन दिए गए हैं :

कथन (I) : 'सही' और 'गलत' पद तर्कों पर लागू होते हैं।

कथन (II) : 'सही' और 'गलत' पद कथनों पर लागू होते हैं।

उपरोक्त कथन के आलोक में, नीचे दिए गए विकल्पों में से सही उत्तर का चयन कीजिए :

- (1) कथन I और II दोनों सत्य हैं।
- (2) कथन I और II दोनों असत्य हैं।
- (3) कथन I सत्य है, लेकिन कथन II असत्य है।
- (4) कथन I असत्य है, लेकिन कथन II सत्य है।

[Question ID = 2705][Question Description = Q27_GP_Set8_S1_Shift2]

1. 1 [Option ID = 10817]
2. 2 [Option ID = 10818]
3. 3 [Option ID = 10819]
4. 4 [Option ID = 10820]

Correct Answer :-

- 1 [Option ID = 10817]

23) Given below are two statements :

Statement I : The fallacy of contradictory middle (viruddha) occurs in an argument when the middle term is found both where the major is found and where it is not found.

Statement II : The fallacy of contradictory middle (viruddha) is committed in an argument when the middle term is found only where major term is absent.

In the light of the above statements, choose the correct answer from the options given below:

- (1) Both Statement I and Statement II are true
- (2) Both Statement I and Statement II are false
- (3) Statement I is true but Statement II is false
- (4) Statement I is false but Statement II is true

नीचे दो कथन दिए गए हैं :

कथन (I) : किसी तर्क में विरुद्ध हेत्वाभास तब होता है जब हेतु दोनों ही स्थितियों में पाया जाता है - जब साध्य का पता लग जाय और उसका पता नहीं लगे।

कथन (II) : किसी तर्क में विरुद्ध हेत्वाभास तब होता है जब हेतु का पता तभी लगे जब साध्य न रहे।

उपरोक्त कथन के आलोक में, नीचे दिए गए विकल्पों में से सही उत्तर का चयन कीजिए :

- (1) कथन I और II दोनों सत्य हैं।
- (2) कथन I और II दोनों असत्य हैं।
- (3) कथन I सत्य है, लेकिन कथन II असत्य है।
- (4) कथन I असत्य है, लेकिन कथन II सत्य है।

[Question ID = 2706][Question Description = Q28_GP_Set8_S1_Shift2]

1. 1 [Option ID = 10821]
2. 2 [Option ID = 10822]
3. 3 [Option ID = 10823]
4. 4 [Option ID = 10824]

Correct Answer :-

- 1 [Option ID = 10821]

24) Given below are two statements : One is labelled as Assertion (A) and the other is labelled as Reason (R) :

Assertion (A) : For Naiyāyikas, logic is not formalized and divorced from existence.

Reasons (R) : Naiyāyika's interest in logic is for finding out the truth about the existent world, but not merely for finding out the instrument of thought for their own sake.

In the light of the above statements, choose the most appropriate answer from the options given below :

- (1) Both (A) and (R) are correct and (R) is the correct explanation of (A)
- (2) Both (A) and (R) are correct and (R) is NOT the correct explanation of (A)
- (3) (A) is correct but (R) is not correct
- (4) (A) is not correct but (R) is correct

गद्य का कथन (A) है . एक आकस्मिकता (ASSERTION A) का रूप में लिखा है (A) दूसरा उक्त कारण (REASON R) का रूप में :

अभिकथन (A) : नैयायिकों के अनुसार, तर्क आकारबद्ध नहीं होता है तथा यह अस्तित्व से विच्छिन्न होता है।

कारण (R) : तर्क में नैयायिकों की रुचि विद्यमान विश्व के सत्य का पता लगाने में है, न कि केवल उनके अपने लिए विचार के साधनों को ढूँढने में।

उपरोक्त कथन के आलोक में, नीचे दीए गए विकल्पों में से सबसे उपयुक्त उत्तर का चयन कीजिए :

- (1) (A) और (R) दोनों सही हैं और (R), (A) की सही व्याख्या है।
- (2) (A) और (R) दोनों सही हैं लेकिन (R), (A) की सही व्याख्या नहीं है।
- (3) (A) सही है लेकिन (R) सही नहीं है।
- (4) (A) सही नहीं है लेकिन (R) सही है।

[Question ID = 2707][Question Description = Q29_GP_Set8_S1_Shift2]

1. 1 [Option ID = 10825]
2. 2 [Option ID = 10826]
3. 3 [Option ID = 10827]
4. 4 [Option ID = 10828]

Correct Answer :-

- 1 [Option ID = 10825]

25) Socialized medicine is not recommended because it would result in reduction of the over all quality of medical care. In addition, it might well bankrupt the federal treasury. This is the whole case against socialized medicine. "What is the conclusion in the above argument?"

- (1) Socialized medicine is not recommended.
- (2) Socialized medicine would result in reduction in the overall quality of medical care.
- (3) Socialized medicine might bankrupt the federal treasury.
- (4) There are overwhelming arguments against socialized medicine.

समाजिकृत औषधि की अनुशंसा नहीं की जाती है क्योंकि इससे चिकित्सा सेवा की सम्पूर्ण गुणवत्ता में हास होगा। इसके अतिरिक्त, इससे संघीय राजकोष भी दिवालिया हो जाएगा। यह समाजिकृत औषधि की पूरी कहानी है। उपर्युक्त तर्क का क्या निष्कर्ष है?

- (1) समाजिकृत औषधि की अनुशंसा नहीं की जाती है।
- (2) समाजिकृत औषधि से चिकित्सा सेवा की सम्पूर्ण गुणवत्ता में हास होगा।
- (3) समाजिकृत औषधि से संघीय राजकोष दिवालिया हो जाएगा।
- (4) समाजिकृत औषधि के विरुद्ध मजबूत तर्क दिए गए हैं।

[Question ID = 2708][Question Description = Q30_GP_Set8_S1_Shift2]

1. 1 [Option ID = 10829]
2. 2 [Option ID = 10830]
3. 3 [Option ID = 10831]
4. 4 [Option ID = 10832]

Correct Answer :-

- 1 [Option ID = 10829]

26) With respect to Computers, which of the following groups consists of volatile memory only?

- | | |
|-----------------------|-----------------------|
| (1) RAM and Pen Drive | (2) Hard Disk and ROM |
| (3) RAM and Cache | (4) Cache and ROM |

कम्प्यूटर के सम्बन्ध में निम्नलिखित में से कौन सा समूह केवल वोलाटाइल मेमोरी का है?

- | | |
|-----------------------|------------------------|
| (1) रैम और पेन ड्राइव | (2) हार्ड डिस्क और रौम |
| (3) रैम और कैश | (4) कैश और रौम |

[Question ID = 2709][Question Description = Q31_GP_Set8_S1_Shift2]

1. 1 [Option ID = 10833]
2. 2 [Option ID = 10834]
3. 3 [Option ID = 10835]
4. 4 [Option ID = 10836]

(4) कथन I असत्य है, लेकिन कथन II सत्य है।

[Question ID = 2711][Question Description = Q33_GP_Set8_S1_Shift2]

1. 1 [Option ID = 10841]
2. 2 [Option ID = 10842]
3. 3 [Option ID = 10843]
4. 4 [Option ID = 10844]

Correct Answer :-

- 1 [Option ID = 10841]

29) Which of the following are software?

- (A) Adobe
- (B) Web browser
- (C) Compiler
- (D) Device Driver

Choose the correct statements from above :

- (1) (A), (B) and (C) only
- (2) (B), (C) and (D) only
- (3) (A), (C) and (D) only
- (4) (A), (B) and (D) only

निम्नलिखित में से कौन सॉफ्टवेयर हैं?

- (A) एडोब
- (B) वेब ब्राउज़र
- (C) कम्पाइलर
- (D) डिवाइस ड्राइवर

नीचे दिए गए विकल्पों में से सही उत्तर का चयन कीजिए :

- (1) केवल (A), (B) और (C)
- (2) केवल (B), (C) और (D)
- (3) केवल (A), (C) और (D)
- (4) केवल (A), (B) और (D)

[Question ID = 2712][Question Description = Q34_GP_Set8_S1_Shift2]

1. 1 [Option ID = 10845]
2. 2 [Option ID = 10846]
3. 3 [Option ID = 10847]
4. 4 [Option ID = 10848]

Correct Answer :-

- 1 [Option ID = 10845]

30) Match List I with List II

List I (Name of Company)	List II (Founder)
(A) Apple Inc.	(I) N.R. Narayana Murthy
(B) Microsoft Inc.	(II) Steve Jobs
(C) Infosys Ltd.	(III) Bill Gates
(D) Airtel	(IV) Sunil Bharti Mittal

Choose the correct answer from the options given below :

- (1) (A)-(III), (B)-(IV), (C)-(II), (D)-(I)
- (2) (A)-(IV), (B)-(III), (C)-(II), (D)-(I)
- (3) (A)-(II), (B)-(IV), (C)-(I), (D)-(III)
- (4) (A)-(II), (B)-(III), (C)-(I), (D)-(IV)

सूची-I के साथ सूची-II का मिलान कीजिए :

सूची-I कम्पनी के नाम	सूची-II संस्थापक
(A) एप्पल इंक.	(I) एन. आर. नारायणमूर्ति

- (B) माइक्रोसाफ्ट इंक. (II) स्टाव जाब्स
(C) इन्फोसिस लिमिटेड (III) बिल गेट्स
(D) एअरटेल (IV) सुनील भारती मित्तल

नीचे दिए गए विकल्पों में से सही उत्तर का चयन कीजिए :

- (1) (A)-(III), (B)-(IV), (C)-(II), (D)-(I)
(2) (A)-(IV), (B)-(III), (C)-(II), (D)-(I)
(3) (A)-(II), (B)-(IV), (C)-(I), (D)-(III)
(4) (A)-(II), (B)-(III), (C)-(I), (D)-(IV)

[Question ID = 2713][Question Description = Q35_GP_Set8_S1_Shift2]

1. 1 [Option ID = 10849]
2. 2 [Option ID = 10850]
3. 3 [Option ID = 10851]
4. 4 [Option ID = 10852]

Correct Answer :-

- 1 [Option ID = 10849]

31) According to one of the Sustainable Development Goals, the per capita global food waste at the retail and consumer levels is to be reduced to the extent of

- (1) 1/2 (Half) (2) 1/3 (One third)
(3) 1/4 (One fourth) (4) 1/10 (One tenth)

धारणीय विकास संवृद्धियों में से एक के अनुसार, खुदरा और उपभोक्ता स्तर पर प्रति व्यक्ति वैश्विक आहार-उच्छिष्ट को किस परिमाण तक घटाया जाए :

- (1) 1/2 (आधा) (2) 1/3 (एक तिहाई)
(3) 1/4 (एक चौथाई) (4) 1/10 (एक दहाई)

[Question ID = 2714][Question Description = Q36_GP_Set8_S1_Shift2]

1. 1 [Option ID = 10853]
2. 2 [Option ID = 10854]
3. 3 [Option ID = 10855]
4. 4 [Option ID = 10856]

Correct Answer :-

- 1 [Option ID = 10853]

32) According to WHO standards, the pesticide content (Lindane or DDT) in drinking water should not exceed

- (1) 1 μgL^{-1} (2) 2 μgL^{-1}
(3) 5 μgL^{-1} (4) 10 μgL^{-1}

विश्व स्वास्थ्य संगठन के अनुसार पेय जल में कीटनाशक की मात्रा (लिण्डेन या डी.डी.टी.) _____ से अधिक नहीं होनी चाहिए:

- (1) 1 μgL^{-1} (2) 2 μgL^{-1}
(3) 5 μgL^{-1} (4) 10 μgL^{-1}

[Question ID = 2715][Question Description = Q37_GP_Set8_S1_Shift2]

1. 1 [Option ID = 10857]
2. 2 [Option ID = 10858]
3. 3 [Option ID = 10859]
4. 4 [Option ID = 10860]

Correct Answer :-

- 1 [Option ID = 10857]

33) Which of the following Pollutants has the least residence time in atmosphere?

- (1) Nitric Oxide (2) Nitrous Oxide
(3) Chlorofluorocarbons (4) Methane

निम्न में से किस प्रदूषक का वायु में न्यूनतम उपस्थिति काल है?

- (1) नाइट्रिक ऑक्साइड (2) नाइट्रस ऑक्साइड

(3) क्लोरो-फ्लोरो-कार्बन

(4) मीथेन

[Question ID = 2716][Question Description = Q38_GP_Set8_S1_Shift2]

1. 1 [Option ID = 10861]
2. 2 [Option ID = 10862]
3. 3 [Option ID = 10863]
4. 4 [Option ID = 10864]

Correct Answer :-

- 1 [Option ID = 10861]

34) Noise levels (db) are referenced to the human hearing threshold at a frequency of

- | | |
|-----------|------------|
| (1) 50 Hz | (2) 100 Hz |
| (3) 1 KHz | (4) 4 KHz |

किस आवृत्ति पर मानव-श्रवण-अवसीमा का ध्वनि प्रदूषण स्तर (डी.बी.) पर सम्बन्ध निर्देश किया जाता है?

- | | |
|-----------|------------|
| (1) 50 Hz | (2) 100 Hz |
| (3) 1 KHz | (4) 4 KHz |

[Question ID = 2717][Question Description = Q39_GP_Set8_S1_Shift2]

1. 1 [Option ID = 10865]
2. 2 [Option ID = 10866]
3. 3 [Option ID = 10867]
4. 4 [Option ID = 10868]

Correct Answer :-

- 1 [Option ID = 10865]

35) International Solar Alliance Framework Agreement entered into force in the year

- | | |
|----------|----------|
| (1) 2015 | (2) 2017 |
| (3) 2016 | (4) 2018 |

अन्तर्राष्ट्रीय सौर गठबंधन सन्धि (इंटरनेशनल सोलर अलायंस फ्रेमवर्क एग्रीमेंट) लागू हुआ ?

- | | |
|----------|----------|
| (1) 2015 | (2) 2017 |
| (3) 2016 | (4) 2018 |

[Question ID = 2718][Question Description = Q40_GP_Set8_S1_Shift2]

1. 1 [Option ID = 10869]
2. 2 [Option ID = 10870]
3. 3 [Option ID = 10871]
4. 4 [Option ID = 10872]

Correct Answer :-

- 1 [Option ID = 10869]

36) In Banabhatta's Kadambri, good education has been described as having knowledge of 64 Kalaa or arts. Among these 64 Kalaa, Which among the following subjects were included

- (1) Only arts such as Singing and Painting
- (2) Only arts and vocational courses
- (3) Arts, vocational courses and Medicine
- (4) Arts, vocational courses, Engineering, Medicine, Mathematic, Science and Many other subjects.

बाणभट्ट की कादम्बरी में, उत्तम शिक्षा का वर्णन 64 कलाओं का ज्ञान रखने के रूप में किया गया है। इन 64 कलाओं में निम्नलिखित में से कौन सम्मिलित थे ?

- (1) केवल गायन और चित्रण जैसी कलायें
- (2) केवल व्यावसायिक पाठ्यक्रम और कलायें
- (3) कलाएँ, व्यावसायिक पाठ्यक्रम, आयुर्विज्ञान
- (4) कलाएँ, व्यावसायिक पाठ्यक्रम, अभियान्त्रिकी, आयुर्विज्ञान, गणित-शास्त्र, विज्ञान और कई अन्य विषय।

[Question ID = 2719][Question Description = Q41_GP_Set8_S1_Shift2]

1. 1 [Option ID = 10873]
2. 2 [Option ID = 10874]
3. 3 [Option ID = 10875]
4. 4 [Option ID = 10876]

Correct Answer :-

- 1 [Option ID = 10873]

37)

Given below are two statements : One is labelled as Assertion (A) and the other is labelled as Reason (R) :

Assertion (A) : Doing Inter – disciplinary research is more challenging than that in within any single discipline.

Reasons (R) : It is not possible to combine knowledge from two disciplines.

In the light of the above statements, choose the correct answer from the options given below :

- (1) Both (A) and (R) are true and (R) is the correct explanation of (A)
- (2) Both (A) and (R) are true but (R) is NOT the correct explanation of (A)
- (3) (A) is true but (R) is false
- (4) (A) is false but (R) is true

नीचे दो कथन दिए गए हैं : एक अभिकथन (Assertion A) के रूप में लिखित है तो दूसरा उसके कारण (Reason R) के रूप में :

अभिकथन (A) : अन्तर विषय शोध करना अधिक चुनौती पूर्ण है, किसी एक अकेले विषय के अन्तर्गत किए गए शोध की तुलना में।

कारण (R) : दो विषयों से प्राप्त ज्ञान का संयोजन सम्भव नहीं है।

उपरोक्त कथन के आलोक में, नीचे दी गई विकल्पों में से सही उत्तर का चयन कीजिए :

- (1) (A) और (R) दोनों सही हैं और (R), (A) की सही व्याख्या है।
- (2) (A) और (R) दोनों सत्य हैं लेकिन (R), (A) की सही व्याख्या नहीं है।
- (3) (A) सत्य है लेकिन (R) असत्य है।
- (4) (A) असत्य है लेकिन (R) सत्य है।

[Question ID = 2720][Question Description = Q42_GP_Set8_S1_Shift2]

1. 1 [Option ID = 10877]
2. 2 [Option ID = 10878]
3. 3 [Option ID = 10879]
4. 4 [Option ID = 10880]

Correct Answer :-

- 1 [Option ID = 10877]

38)

Empirical studies have shown that the women students are under represented in the disciplines such as science, technology, engineering, and mathematics (STEM). Its possible reasons could be

- (A) Women students do not feel comfortable with STEM subjects.
- (B) Women students cannot excel in STEM subjects
- (C) Woment students lack in aptitude in STEM subjects
- (D) Women students face threats due to negative stereotypes.
- (E) Women students are not encouraged by the parents to join STEM disciplines.

Choose the correct answer from the options given below :

- (1) (A), (C), (E) only
- (2) (B), (E) only
- (3) (C), (D) only
- (4) (D), (E) only

- (1) कथन I और II दोनों सत्य हैं ।
- (2) कथन I और II दोनों असत्य हैं ।
- (3) कथन I सत्य है, लेकिन कथन II असत्य है।
- (4) कथन I असत्य है, लेकिन कथन II सत्य है।

[Question ID = 2722][Question Description = Q44_GP_Set8_S1_Shift2]

1. 1 [Option ID = 10885]
2. 2 [Option ID = 10886]
3. 3 [Option ID = 10887]
4. 4 [Option ID = 10888]

Correct Answer :-

- 1 [Option ID = 10885]

40) Global Citizenship Education (GCED) aims at

- (A) Making students to become members of U.N.O.
- (B) Helping students to understand contemporary global challenges.
- (C) Making students to become promoters of peaceful societies.
- (D) Making students eligible to join foreign services.
- (E) Making students eligible to become diplomats.

Choose the correct answer from the options given below :

- (1) (A), (B) only (2) (B), (C) only
- (3) (C), (D) only (4) (D), (E) only

वैश्विक नागरिकता शिक्षा (जी.सी.ई.डी) का उद्देश्य है।

- (A) विद्यार्थियों को यू.एन.ओ. का सदस्य बनने के लिए तैयार करना।
- (B) विद्यार्थियों को समसामयिक वैश्विक चुनौतियों को समझने में सहायता करना।
- (C) विद्यार्थियों को शांतिपूर्ण समाज का प्रोत्साहनकर्ता बनने के लिए तैयार करना।
- (D) विद्यार्थियों को विदेश सेवाओं में जाने के योग्य बनाना।
- (E) विद्यार्थियों को राजनयिक बनने के योग्य बनाना।

नीचे दिए गए विकल्पों में से सही उत्तर का चयन कीजिए :

- (1) केवल (A), (B) (2) केवल (B), (C)
- (3) केवल (C), (D) (4) केवल (D), (E)

[Question ID = 2723][Question Description = Q45_GP_Set8_S1_Shift2]

1. 1 [Option ID = 10889]
2. 2 [Option ID = 10890]

3. 3 [Option ID = 10891]

4. 4 [Option ID = 10892]

Correct Answer :-

• 1 [Option ID = 10889]

Topic:- GP_Set8_C

1) Read the passage and answer question

The need for a theory of justice relates to the discipline of engagement in reasoning about a subject on which it is as eminent author Burke noted, very difficult to speak. It is sometimes claimed that justice is not a matter of reasoning at all; it is one of being appropriately sensitive and having the right note for injustice. It is easy to be tempted to think along these lines. When we find, for example, a raging female, it seems natural to protest rather than reason elaborately about justice and injustice. And yet a calamity would be a case of injustice only if it could have been prevented, and particularly if those who could have undertaken preventive action had failed to try. Reasoning in some form cannot but be involved in moving from the observation of a tragedy to the diagnosis of injustice. Further more, cases of injustice may be much more complex and subtle than the assessment of an observable calamity. There could be different arguments suggesting disparate conclusions, and evaluations of justice may be anything but straight forward. The avoidance of reasoned justification often comes not from indignant protestors but from placid guardians of order and justice. Reticence has appealed throughout history to those with a governing role, endowed with public authority, who are unsure of the grounds for action, or unwilling to scrutinize the basis of their policies. The requirements of a theory of justice include bringing reason into play in the diagnosis of justice and injustice. Over hundreds of years, writers on justice in different parts of the world have attempted to provide the intellectual basis for moving from a general sense of injustice to particular reasoned diagnosis of injustice.

What is central to the theory of justice?

- | | |
|----------------------------|--------------------------------|
| (1) Reasoning on a subject | (2) Difficult interpretations |
| (3) Subjective engagement | (4) Identification of an issue |

निम्नलिखित गद्यांश को पढ़िए और प्रश्न के उत्तर दीजिए :

न्याय के सिद्धान्त की आवश्यकता का संबंध किसी ऐसे विषय के बारे में तर्क के अनुशासन को लागू करने से संबंधित होने से है जिसके विषय में बर्क जैसे विख्यात लेखक ने भी कुछ कहना बहुत कठिन बताया है। कभी-कभी यह दावा किया जाता है कि न्याय को तर्क का विषय बिलकुल नहीं कहा जा सकता; यह उनमें से एक है जिनमें उपयुक्त संवेदना के साथ-साथ अन्याय की सही समझ हो। इस रूप में सोचने के लिए प्रेरित होना आसान है। उदाहरण के लिए, जब हम पाते हैं कि किसी भीषण अकाल की स्थिति में न्याय तथा अन्याय के बारे में विस्तारपूर्वक तर्क-वितर्क करने की अपेक्षा इसका विरोध करना स्वाभाविक है। पुनश्च कोई आपदा तभी एक अन्याय हो सकती है यदि इसका निवारण किया जा सके, तथा विशेष रूप से वे लोग जो इस विषय में निवारणात्मक कार्य कर सकते थे, ऐसा करने के प्रयास में असफल रहे। किसी रूप में तर्क कुछ और नहीं, बल्कि किसी त्रासदी के अवलोकन से अन्याय के निदान की तरफ बढ़ने की यात्रा है। इसके अतिरिक्त, अन्याय के विषय अवलोकन किए जाने लायक आपदा के मूल्यांकन की तुलना में अधिक जटिल और सूक्ष्म हैं। यहां भिन्न-भिन्न निष्कर्षों के सुझाव वाले अलग-अलग तर्क हो सकते हैं और न्याय का मूल्यांकन कुछ भी हो सकता है पर सीधे सीधे। प्रायः न्याय के तर्कयुक्त प्रतिपादन का परिहार रूढ़ विरोधकर्ताओं से नहीं, बल्कि व्यवस्था तथा न्याय के शांतिप्रिय संरक्षकों से हो पाता है। इतिहास गवाह है कि मौन केवल उन्हीं को भाता रहा है - जिन्हें नियंत्रण संबंधी भूमिका, लोक प्राधिकार प्राप्त है तथा जो कार्रवाई करने के आधार के बारे में अनिश्चय की स्थिति में हैं अथवा अपनी नीति के आधार की छानबीन करने के इच्छुक नहीं हैं। न्याय के सिद्धान्त की आवश्यकता में न्याय तथा अन्याय के निदान में तर्क की भूमिका होती है। सैकड़ों वर्षों से विश्व के विभिन्न भागों में न्याय के संबंध में लिखने वाले लेखकों ने अन्याय सामान्य अर्थ से अन्याय के विशेष तर्कपूर्ण निदान की ओर जाने हेतु बौद्धिक आधार प्रदान करने का प्रयास किया है।

न्याय के सिद्धान्त का केंद्र क्या है?

- | | |
|--------------------------------|----------------------------|
| (1) किसी विषय के बारे में तर्क | (2) विभिन्न व्याख्याएं |
| (3) व्यक्तिनिष्ठ संलग्नता | (4) किसी विषय का तादात्म्य |

1. 1 [Option ID = 10893]
2. 2 [Option ID = 10894]
3. 3 [Option ID = 10895]
4. 4 [Option ID = 10896]

Correct Answer :-

- 1 [Option ID = 10893]

2) Read the passage and answer question

The need for a theory of justice relates to the discipline of engagement in reasoning about a subject on which it is as eminent author Burke noted, very difficult to speak. It is sometimes claimed that justice is not a matter of reasoning at all; it is one of being appropriately sensitive and having the right note for injustice. It is easy to be tempted to think along these lines. When we find, for example, a raging female, it seems natural to protest rather than reason elaborately about justice and injustice. And yet a calamity would be a case of injustice only if it could have been prevented, and particularly if those who could have undertaken preventive action had failed to try. Reasoning in some form cannot but be involved in moving from the observation of a tragedy to the diagnosis of injustice. Further more, cases of injustice may be much more complex and subtle than the assessment of an observable calamity. There could be different arguments suggesting disparate conclusions, and evaluations of justice may be anything but straight forward. The avoidance of reasoned justification often comes not from indignant protestors but from placid guardians of order and justice. Reticence has appealed throughout history to those with a governing role, endowed with public authority, who are unsure of the grounds for action, or unwilling to scrutinize the basis of their policies. The requirements of a theory of justice include bringing reason into play in the diagnosis of justice and injustice. Over hundreds of years, writers on justice in different parts of the world have attempted to provide the intellectual basis for moving from a general sense of injustice to particular reasoned diagnosis of injustice.

What is the simplistic view about justice?

- (1) It is a matter of reasoning
- (2) It is being appropriately made aware of injustice
- (3) It is of very little significance
- (4) It is a matter of protest

निम्नलिखित गद्यांश को पढ़िए और प्रश्न के उत्तर दीजिए :

न्याय के सिद्धांत की आवश्यकता का संबंध किसी ऐसे विषय के बारे में तर्क के अनुशासन को लागू करने से संबंधित होने से है जिसके विषय में बर्क जैसे विख्यात लेखक ने भी कुछ कहना बहुत कठिन बताया है। कभी-कभी यह दावा किया जाता है कि न्याय को तर्क का विषय बिल्कुल नहीं कहा जा सकता; यह उनमें से एक है जिनमें उपयुक्त संवेदना के साथ-साथ अन्याय की सही समझ हो। इस रूप में सोचने के लिए प्रेरित होना आसान है। उदाहरण के लिए, जब हम पाते हैं कि किसी भीषण अकाल की स्थिति में न्याय तथा अन्याय के बारे में विस्तारपूर्वक तर्क-वितर्क करने की अपेक्षा इसका विरोध करना स्वाभाविक है। पुनश्च कोई आपदा तभी एक अन्याय हो सकती है यदि इसका निवारण किया जा सके, तथा विशेष रूप से वे लोग जो इस विषय में निवारणात्मक कार्य कर सकते थे, ऐसा करने के प्रयास में असफल रहे। किसी रूप में तर्क कुछ और नहीं, बल्कि किसी त्रासदी के अवलोकन से अन्याय के निदान की तरफ बढ़ने की यात्रा है। इसके अतिरिक्त, अन्याय के विषय अवलोकन किए जाने लायक आपदा के मूल्यांकन की तुलना में अधिक जटिल और सूक्ष्म हैं। यहां भिन्न-भिन्न निष्कर्षों के सुझाव वाले अलग-अलग तर्क हो सकते हैं और न्याय का मूल्यांकन कुछ भी हो सकता है पर सीधे सीधे। प्रायः न्याय के तर्कयुक्त प्रतिपादन का परिहार रुष्ट विरोधकर्ताओं से नहीं, बल्कि व्यवस्था तथा न्याय के शांतिप्रिय संरक्षकों से हो पाता है। इतिहास गवाह है कि मौन केवल उन्हीं को भाता रहा है - जिन्हें नियंत्रण संबंधी भूमिका, लोक प्राधिकार प्राप्त है तथा जो कार्रवाई करने के आधार के बारे में अनिश्चय की स्थिति में हैं अथवा अपनी नीति के आधार की छानबीन करने के इच्छुक नहीं हैं। न्याय के सिद्धान्त की आवश्यकता में न्याय तथा अन्याय के निदान में तर्क की भूमिका होती है। सैकड़ों वर्षों से विश्व के विभिन्न भागों में न्याय के संबंध में लिखने वाले लेखकों ने अन्याय सामान्य अर्थ से अन्याय के विशेष तर्कपूर्ण निदान की ओर जाने हेतु बौद्धिक आधार प्रदान करने का प्रयास किया है।

न्याय के विषय में एकपक्षीय विचार क्या है?

- (1) यह तर्क का विषय है।
- (2) यह अन्याय के बारे में समुचित रूप से जानकारी प्राप्त करता है।

(3) यह बहुत कम महत्वपूर्ण है।

(4) यह विरोध का विषय है।

[Question ID = 2725][Question Description = Q47_GP_SET8_S1_Shift2]

1. 1 [Option ID = 10897]
2. 2 [Option ID = 10898]
3. 3 [Option ID = 10899]
4. 4 [Option ID = 10900]

Correct Answer :-

- 1 [Option ID = 10897]

3) Read the passage and answer question

The need for a theory of justice relates to the discipline of engagement in reasoning about a subject on which it is as eminent author Burke noted, very difficult to speak. It is sometimes claimed that justice is not a matter of reasoning at all; it is one of being appropriately sensitive and having the right note for injustice. It is easy to be tempted to think along these lines. When we find, for example, a raging femine, it seems natural to protest rather than reason elaborately about justice and injustice. And yet a calamity would be a case of injustice only if it could have been prevented, and particularly if those who could have undertaken preventive action had failed to try. Reasoning in some form cannot but be involved in moving from the observation of a tragedy to the diagnosis of injustice. Further more, cases of injustice may be much more complex and subtle than the assessment of an observable calamity. There could be different arguments suggesting disparate conclusions, and evaluations of justice may be anything but straight forward. The avoidance of reasoned justification often comes not from indignant protestors but from placid guardians of order and justice. Reticence has appealed throughout history to those with a governing role, endowed with public authority, who are unsure of the grounds for action, or unwilling to scrutinize the basis of their policies. The requirements of a theory of justice include bringing reason into play in the diagnosis of justice and injustice. Over hundreds of years, writers on justice in different parts of the world have attempted to provide the intellectual basis for moving from a general sense of injustice to particular reasoned diagnosis of injustice.

In the case of a calamity, it should lead to a feeling of injustice when

- (1) It is left unobserved
- (2) It affects vulnerable people
- (3) Concerned authorities did not make an attempt to prevent it
- (4) Concerned authorities did not know how to prevent it

निम्नलिखित गद्यांश को पढ़िए और प्रश्न के उत्तर दीजिए :

न्याय के सिद्धांत की आवश्यकता का संबंध किसी ऐसे विषय के बारे में तर्क के अनुशासन को लागू करने से संबंधित होने से है जिसके विषय में बर्क जैसे विख्यात लेखक ने भी कुछ कहना बहुत कठिन बताया है। कभी-कभी यह दावा किया जाता है कि न्याय को तर्क का विषय बिलकुल नहीं कहा जा सकता; यह उनमें से एक है जिनमें उपयुक्त संवेदना के साथ-साथ अन्याय की सही समझ हो। इस रूप में सोचने के लिए प्रेरित होना आसान है। उदाहरण के लिए, जब हम पाते हैं कि किसी भीषण अकाल की स्थिति में न्याय तथा अन्याय के बारे में विस्तारपूर्वक तर्क-वितर्क करने की अपेक्षा इसका विरोध करना स्वाभाविक है। पुनश्च कोई आपदा तभी एक अन्याय हो सकती है यदि इसका निवारण किया जा सके, तथा विशेष रूप से वे लोग जो इस विषय में निवारणात्मक कार्य कर सकते थे, ऐसा करने के प्रयास में असफल रहे। किसी रूप में तर्क कुछ और नहीं, बल्कि किसी त्रासदी के अवलोकन से अन्याय के निदान की तरफ बढ़ने की यात्रा है। इसके अतिरिक्त, अन्याय के विषय अवलोकन किए जाने लायक आपदा के मूल्यांकन की तुलना में अधिक जटिल और सूक्ष्म हैं। यहां भिन्न-भिन्न निष्कर्षों के सुझाव वाले अलग-अलग तर्क हो सकते हैं और न्याय का मूल्यांकन कुछ भी हो सकता है पर सीधे सीधे। प्रायः न्याय के तर्कयुक्त प्रतिपादन का परिहार रुढ़ विरोधकर्ताओं से नहीं, बल्कि व्यवस्था तथा न्याय के शांतिप्रिय संरक्षकों से हो पाता है। इतिहास गवाह है कि मौन केवल उन्हीं को भाता रहा है - जिन्हें नियंत्रण संबंधी भूमिका, लोक प्राधिकार प्राप्त है तथा जो कार्रवाई करने के आधार के बारे में अनिश्चय की स्थिति में हैं अथवा अपनी नीति के आधार की छानबीन करने के इच्छुक नहीं हैं। न्याय के सिद्धान्त की आवश्यकता में न्याय तथा अन्याय के निदान में तर्क की भूमिका होती है। सैकड़ों वर्षों से विश्व के विभिन्न भागों में न्याय के संबंध में लिखने वाले लेखकों ने अन्याय सामान्य अर्थ से अन्याय के विशेष तर्कपूर्ण निदान की ओर जाने हेतु बौद्धिक आधार प्रदान करने का प्रयास किया है।

किसी आपदा के घटित होने के मामले में,

- (1) इसका अवलोकन नहीं किया जाना चाहिए।
- (2) यह कमजोर लोगों को प्रभावित करता है।
- (3) संबंधित प्राधिकारी इसके निवारण का प्रयास नहीं करते।
- (4) संबंधित अधिकारियों को इस बात की जानकारी नहीं होती कि इसका निवारण कैसे किया जाए।

[Question ID = 2726][Question Description = Q48_GP_SET8_S1_Shift2]

1. 1 [Option ID = 10901]
2. 2 [Option ID = 10902]
3. 3 [Option ID = 10903]
4. 4 [Option ID = 10904]

Correct Answer :-

- 1 [Option ID = 10901]

4) Read the passage and answer question

The need for a theory of justice relates to the discipline of engagement in reasoning about a subject on which it is as eminent author Burke noted, very difficult to speak. It is sometimes claimed that justice is not a matter of reasoning at all; it is one of being appropriately sensitive and having the right note for injustice. It is easy to be tempted to think along these lines. When we find, for example, a raging femine, it seems natural to protest rather than reason elaborately about justice and injustice. And yet a calamity would be a case of injustice only if it could have been prevented, and particularly if those who could have undertaken preventive action had failed to try. Reasoning in some form cannot but be involved in moving from the observation of a tragedy to the diagnosis of injustice. Further more, cases of injustice may be much more complex and subtle than the assessment of an observable calamity. There could be different arguments suggesting disparate conclusions, and evaluations of justice may be anything but straight forward. The avoidance of reasoned justification often comes not from indignant protestors but from placid guardians of order and justice. Reticence has appealed throughout history to those with a governing role, endowed with public authority, who are unsure of the grounds for action, or unwilling to scrutinize the basis of their policies. The requirements of a theory of justice include bringing reason into play in the diagnosis of justice and injustice. Over hundreds of years, writers on justice in different parts of the world have attempted to provide the intellectual basis for moving from a general sense of injustice to particular reasoned diagnosis of injustice.

Avoidance of reasoned justification can be sourced to

- (1) Protectors seeking justice
- (2) People unaffected by policy - decisions
- (3) The public not interested in justice
- (4) Public authority

निम्नलिखित गद्यांश को पढ़िए और प्रश्न के उत्तर दीजिए :

न्याय के सिद्धांत की आवश्यकता का संबंध किसी ऐसे विषय के बारे में तर्क के अनुशासन को लागू करने से संबंधित होने से है जिसके विषय में बर्क जैसे विख्यात लेखक ने भी कुछ कहना बहुत कठिन बताया है। कभी-कभी यह दावा किया जाता है कि न्याय को तर्क का विषय बिलकुल नहीं कहा जा सकता; यह उनमें से एक है जिनमें उपयुक्त संवेदना के साथ-साथ अन्याय की सही समझ हो। इस रूप में सोचने के लिए प्रेरित होना आसान है। उदाहरण के लिए, जब हम पाते हैं कि किसी भीषण अकाल की स्थिति में न्याय तथा अन्याय के बारे में विस्तारपूर्वक तर्क-वितर्क करने की अपेक्षा इसका विरोध करना स्वाभाविक है। पुनश्च कोई आपदा तभी एक अन्याय हो सकती है यदि इसका निवारण किया जा सके, तथा विशेष रूप से वे लोग जो इस विषय में निवारणात्मक कार्य कर सकते थे, ऐसा करने के प्रयास में असफल रहे। किसी रूप में तर्क कुछ और नहीं, बल्कि किसी त्रासदी के अवलोकन से अन्याय के निदान की तरफ बढ़ने की यात्रा है। इसके अतिरिक्त, अन्याय के विषय अवलोकन किए जाने लायक आपदा के मूल्यांकन की तुलना में अधिक जटिल और सूक्ष्म हैं। यहां भिन्न-भिन्न निष्कर्षों के सुझाव वाले अलग-अलग तर्क हो सकते हैं और न्याय का मूल्यांकन कुछ भी हो सकता है पर सीधे सीधे। प्रायः न्याय के तर्कयुक्त प्रतिपादन का परिहार रूढ़ विरोधकर्ताओं से नहीं, बल्कि व्यवस्था तथा न्याय के शांतिप्रिय संरक्षकों से हो पाता है। इतिहास गवाह है कि मौन केवल उन्हीं को भाता रहा है - जिन्हें नियंत्रण संबंधी भूमिका, लोक प्राधिकार प्राप्त है तथा जो कार्रवाई करने के आधार के बारे में अनिश्चय की स्थिति में हैं अथवा अपनी नीति के आधार की छानबीन करने के इच्छुक नहीं हैं। न्याय के सिद्धान्त की

आवश्यकता में न्याय तथा अन्याय के निदान में तर्क का भूमिका होता है। सकड़ा वषा स तवश्व क त्वाभन्न भागा म न्याय क संबंध में लिखने वाले लेखकों ने अन्याय सामान्य अर्थ से अन्याय के विशेष तर्कपूर्ण निदान की ओर जाने हेतु बौद्धिक आधार प्रदान करने का प्रयास किया है।

तर्कपूर्ण न्याय के प्रतिपादन का परिहार करने का स्रोत होता है

- (1) न्याय चाहने वाले विरोधकर्ता
- (2) नीतिगत निर्णयों से प्रभावित लोग
- (3) न्याय में रुचि नहीं रखने वाली आम जनता
- (4) सार्वजनिक प्राधिकारी

[Question ID = 2727][Question Description = Q49_GP_SET8_S1_Shift2]

1. 1 [Option ID = 10905]
2. 2 [Option ID = 10906]
3. 3 [Option ID = 10907]
4. 4 [Option ID = 10908]

Correct Answer :-

- 1 [Option ID = 10905]

5) Read the passage and answer question

The need for a theory of justice relates to the discipline of engagement in reasoning about a subject on which it is as eminent author Burke noted, very difficult to speak. It is sometimes claimed that justice is not a matter of reasoning at all; it is one of being appropriately sensitive and having the right note for injustice. It is easy to be tempted to think along these lines. When we find, for example, a raging female, it seems natural to protest rather than reason elaborately about justice and injustice. And yet a calamity would be a case of injustice only if it could have been prevented, and particularly if those who could have undertaken preventive action had failed to try. Reasoning in some form cannot but be involved in moving from the observation of a tragedy to the diagnosis of injustice. Further more, cases of injustice may be much more complex and subtle than the assessment of an observable calamity. There could be different arguments suggesting disparate conclusions, and evaluations of justice may be anything but straight forward. The avoidance of reasoned justification often comes not from indignant protestors but from placid guardians of order and justice. Reticence has appealed throughout history to those with a governing role, endowed with public authority, who are unsure of the grounds for action, or unwilling to scrutinize the basis of their policies. The requirements of a theory of justice include bringing reason into play in the diagnosis of justice and injustice. Over hundreds of years, writers on justice in different parts of the world have attempted to provide the intellectual basis for moving from a general sense of injustice to particular reasoned diagnosis of injustice.

A particular diagnosis of injustice will lead to a theory of justice based on

- (1) A general sense of the issues
- (2) Empirical analysis of injustice
- (3) Intellectual evaluations
- (4) Historical traditions

निम्नलिखित गद्यांश को पढ़िए और प्रश्न के उत्तर दीजिए :

न्याय के सिद्धांत की आवश्यकता का संबंध किसी ऐसे विषय के बारे में तर्क के अनुशासन को लागू करने से संबंधित होने से है जिसके विषय में बर्क जैसे विख्यात लेखक ने भी कुछ कहना बहुत कठिन बताया है। कभी-कभी यह दावा किया जाता है कि न्याय को तर्क का विषय बिल्कुल नहीं कहा जा सकता; यह उनमें से एक है जिनमें उपयुक्त संवेदना के साथ-साथ अन्याय की सही समझ हो। इस रूप में सोचने के लिए प्रेरित होना आसान है। उदाहरण के लिए, जब हम पाते हैं कि किसी भीषण अकाल की स्थिति में न्याय तथा अन्याय के बारे में विस्तारपूर्वक तर्क-वितर्क करने की अपेक्षा इसका विरोध करना स्वाभाविक है। पुनश्च कोई आपदा तभी एक अन्याय हो सकती है यदि इसका निवारण किया जा सके, तथा विशेष रूप से वे लोग जो इस विषय में निवारणात्मक कार्य कर सकते थे, ऐसा करने के प्रयास में असफल रहे। किसी रूप में तर्क कुछ और नहीं, बल्कि किसी त्रासदी के अवलोकन से अन्याय के निदान की तरफ बढ़ने की यात्रा है। इसके अतिरिक्त, अन्याय के विषय अवलोकन

एक जान लायक आपदा क मूल्यांकन का तुलना म आधक जाटल आर सूक्ष्म ह। यहा अभन्न-अभन्न तन्त्रिका क सुझाव वाल अलग-अलग तर्क हो सकते हैं और न्याय का मूल्यांकन कुछ भी हो सकता है पर सीधे सीधे। प्रायः न्याय के तर्कयुक्त प्रतिपादन का परिहार रूढ विरोधकर्ताओं से नहीं, बल्कि व्यवस्था तथा न्याय के शांतिप्रिय संरक्षकों से हो पाता है। इतिहास गवाह है कि मौन केवल उन्हीं को भाता रहा है - जिन्हें नियंत्रण संबंधी भूमिका, लोक प्राधिकार प्राप्त है तथा जो कार्रवाई करने के आधार के बारे में अनिश्चय की स्थिति में हैं अथवा अपनी नीति के आधार की छानबीन करने के इच्छुक नहीं हैं। न्याय के सिद्धान्त की आवश्यकता में न्याय तथा अन्याय के निदान में तर्क की भूमिका होती है। सैकड़ों वर्षों से विश्व के विभिन्न भागों में न्याय के संबंध में लिखने वाले लेखकों ने अन्याय सामान्य अर्थ से अन्याय के विशेष तर्कपूर्ण निदान की ओर जाने हेतु बौद्धिक आधार प्रदान करने का प्रयास किया है।

न्याय के विशेष निदान से न्याय के एक सिद्धान्त का निर्माण होगा जो _____ पर आधारित होगा।

- (1) विषयों का सामान्य बोध
- (2) अन्याय का आनुभविक विश्लेषण
- (3) बौद्धिक मूल्यांकन
- (4) ऐतिहासिक परंपरा

[Question ID = 2728][Question Description = Q50_GP_SET8_S1_Shift2]

1. 1 [Option ID = 10909]
2. 2 [Option ID = 10910]
3. 3 [Option ID = 10911]
4. 4 [Option ID = 10912]

Correct Answer :-

- 1 [Option ID = 10909]

