

PART A – PHYSICS

1. The pressure that has to be applied to the ends of a steel wire of length 10 cm to keep its length constant when its temperature is raised by 100°C is :

(For steel Young's modulus is $2 \times 10^{11} \text{ N m}^{-2}$ and coefficient of thermal expansion is $1.1 \times 10^{-5} \text{ K}^{-1}$)

- (1) $2.2 \times 10^7 \text{ Pa}$ (2) $2.2 \times 10^6 \text{ Pa}$
 (3) $2.2 \times 10^8 \text{ Pa}$ (4) $2.2 \times 10^9 \text{ Pa}$

Ans. (3)

Sol. Thermal strain = $\alpha \Delta T$

(by $l = l_0 (1 + \alpha \Delta T)$)

\Rightarrow Thermal stress in Rod (Pressure due to Thermal strain) = $Y \alpha \Delta T$

$$= 2 \times 10^{11} \times 1.1 \times 10^{-5} \times 100$$

$$= 2.2 \times 10^8 \text{ Pa}$$

2. A conductor lies along the z-axis at $-1.5 \leq z < 1.5 \text{ m}$ and carries a fixed current of 10.0 A in $-\hat{a}_z$ direction (see figure). For a field $\vec{B} = 3.0 \times 10^{-4} e^{-0.2x} \hat{a}_y \text{ T}$, find the power required to move the conductor at constant speed to $x = 2.0 \text{ m}$, $y = 0 \text{ m}$ in $5 \times 10^{-3} \text{ s}$. Assume parallel motion along the x-axis.

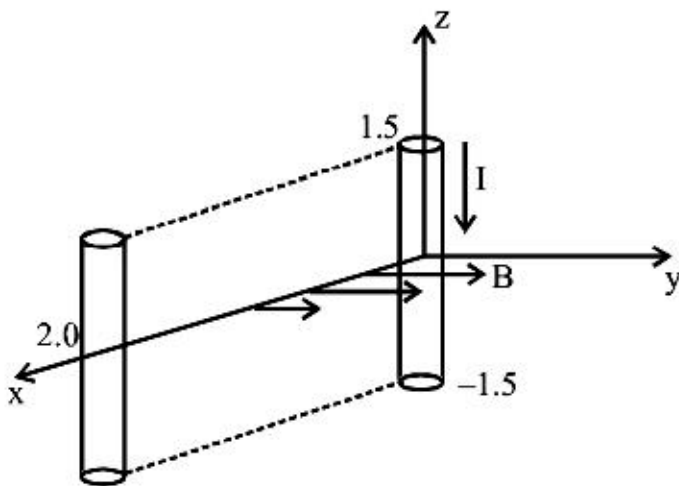

- (1) 14.85 W (2) 29.7 W
 (3) 1.57 W (4) 2.97 W

Ans. (4)

Sol. Force on Conductor $F = i \ell B$

$$F = (10)(3) (3 \times 10^{-4} e^{-0.2x})$$

$$\vec{F} = 90 \times 10^{-4} (e^{-0.2x}) \hat{a}_x$$

$$\text{Work done } W = \int_{x=0}^{x=2} F dx$$

$$W = 90 \times 10^{-4} \int_0^2 e^{-0.2x} dx$$

$$W = 90 \times 10^{-4} \left[\frac{e^{-0.2x}}{-0.2} \right]_{x=0}^{x=2}$$

$$= 90 \times 10^{-4} \left[\frac{e^{-0.4} - 1}{-0.2} \right]$$

Now Average power

$$P_{\text{avg.}} = \frac{\text{work}}{\text{time}}$$

$$P_{\text{avg.}} = \frac{90 \times 10^{-4} \times (1 - e^{-0.4})}{5 \times 10^{-3} \times 0.2}$$

$$P_{\text{avg.}} = 2.97 \text{ Watt}$$

3. A bob of mass m attached to an inextensible string of length ℓ is suspended from a vertical support. The bob rotates in a horizontal circle with an angular speed $\omega \text{ rad/s}$ about the vertical. About the point of suspension :

- (1) Angular momentum changes in direction but not in magnitude
 (2) Angular momentum changes both in direction and magnitude
 (3) Angular momentum is conserved
 (4) Angular momentum changes in magnitude but not in direction.

Ans. (1)

Sol.

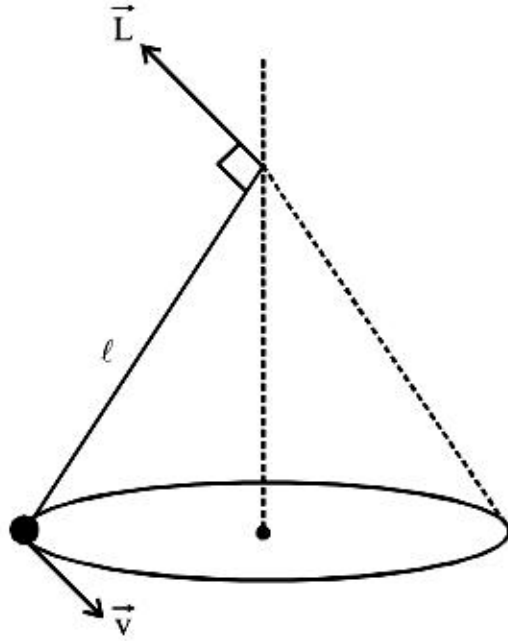

$\vec{\tau}$ of mg is perpendicular to \vec{L} . Hence magnitude of \vec{L} is constant but direction will change.

4. The current voltage relation of diode is given by $I = (e^{1000V/T} - 1)$ mA, where the applied voltage V is in volts and the temperature T is in degree Kelvin. If a student makes an error measuring $\pm 0.01V$ while measuring the current of 5 mA at 300 K, what will be error in the value of current in mA ?

- (1) 0.5 mA (2) 0.05 mA
 (3) 0.2 mA (4) 0.02 mA

Ans. (3)

Sol. Given current $I = (e^{1000V/T} - 1)$ mA

$$\Rightarrow I + 1 = e^{1000V/T}$$

$$dI = \frac{1000}{T} \left[e^{\frac{1000V}{T}} \right] dV$$

$$dI = \frac{1000}{T} [I + 1] dV$$

$$= \frac{1000}{300} [6] \times (0.01)$$

$$dI = 0.2 \text{ mA}$$

5. An open glass tube is immersed in mercury in such a way that a length of 8 cm extends above the mercury level. The open of the tube is then closed and sealed and the tube is raised vertically up by addition 46 cm. What will be length of the air column above mercury in the tube now ?

(Atmospheric pressure = 76 cm of Hg)

- (1) 38 cm (2) 6 cm (3) 16 cm (4) 22 cm

Ans. (3)

Sol.

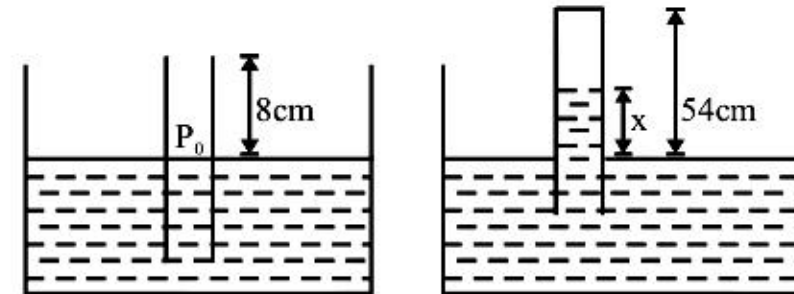

$$P_0 A(8) = P' A(54 - x)$$

$$P_0 8 = P' (54 - x) \quad \dots\dots(1)$$

$$P' = P_0 - \rho gx \quad \dots\dots(2)$$

$$\text{Comparing } (P_0)8 = (P_0 - \rho gx) (54 - x)$$

$$(76)8 = (76 - x) (54 - x)$$

Solving we get $x = 38$ cm

Air column = $54 - 38 = 16$ cm

hence 3 option is correct.

6. Match **List-I** (Electromagnetic wave type) with **List-II** (Its association/application) and select the correct option from the choices given below the lists :

List-I		List-II	
(a)	Infrared waves	(i)	To treat muscular strain
(b)	Radio waves	(ii)	For broadcasting
(c)	X-rays	(iii)	To detect fracture of bones
(d)	Ultraviolet rays	(iv)	Absorbed by the ozone layer of the atmosphere

- (a) (b) (c) (d)
 (1) (iii) (ii) (i) (iv)
 (2) (i) (ii) (iii) (iv)
 (3) (iv) (iii) (ii) (i)
 (4) (i) (ii) (iv) (iii)

Ans. (2)

Sol. Factual question

7. A parallel plate capacitor is made of two circular plates separated by a distance of 5 mm and with a dielectric of dielectric constant 2.2 between them. When the electric field in the dielectric is 3×10^4 V/m, the charge density of the positive plate will be close to :

- (1) 3×10^4 C/m² (2) 6×10^4 C/m²
 (3) 6×10^{-7} C/m² (4) 3×10^{-7} C/m²

Ans. (3)

Sol. $\frac{\sigma}{K\epsilon_0} = 3 \times 10^4$

$$\frac{\sigma}{2.25 \times 8.86 \times 10^{-12}} = 3 \times 10^4$$

$$\sigma = 6 \times 10^{-7} \text{ C/m}^2$$

8. A student measured the length of a rod and wrote it as 3.50 cm. Which instrument did he use to measure it ?

- (1) A screw gauge having 100 divisions in the circular scale and pitch as 1 mm.
 (2) A screw gauge having 50 divisions in the circular scale and pitch as 1 mm.
 (3) A meter scale
 (4) A vernier calliper where the 10 divisions in vernier scale matches with 9 division in main scale and main scale has 10 divisions in 1 cm.

Ans. (4)

Sol. Least count of vernier calliper is 0.01 cm
 Hence it matches with the reading.

9. Four particles, each of mass M and equidistant from each other, move along a circle of radius R under the action of their mutual gravitational attraction. The speed of each particle is :

(1) $\sqrt{\frac{GM}{R}}(1+2\sqrt{2})$ (2) $\frac{1}{2}\sqrt{\frac{GM}{R}}(1+2\sqrt{2})$

(3) $\sqrt{\frac{GM}{R}}$ (4) $\sqrt{2\sqrt{2}\frac{GM}{R}}$

Ans. (2)

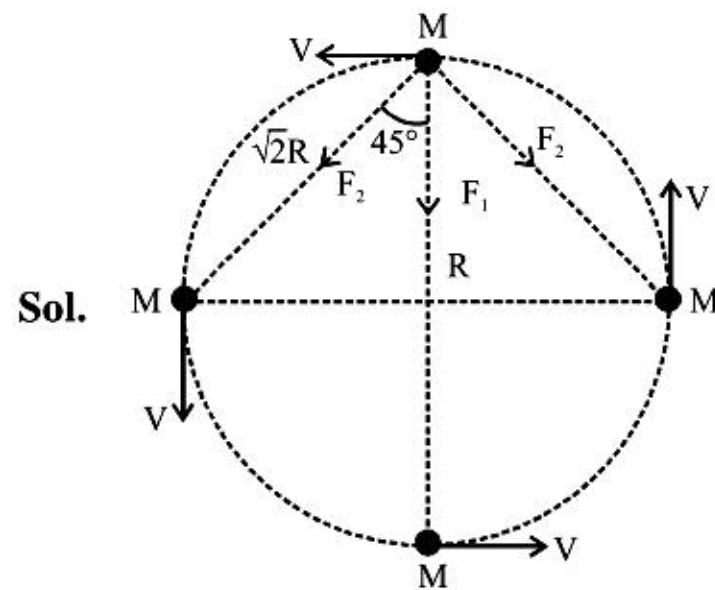

Sol.

Net force on one particle

$$F_{\text{net}} = F_1 + 2F_2 \cos 45^\circ = \text{Centripetal force}$$

$$\Rightarrow \frac{GM^2}{(2R)^2} + \left[\frac{2GM^2}{(\sqrt{2}R)^2} \cos 45^\circ \right] = \frac{MV^2}{R}$$

$$V = \frac{1}{2} \sqrt{\frac{GM}{R}} (1 + 2\sqrt{2})$$

10. In a large building, there are 15 bulbs of 40 W, 5 bulbs of 100 W, 5 fans of 80 W and 1 heater of 1 kW. The voltage of the electric mains is 220 V. The minimum capacity of the main fuse of the building will be :

- (1) 12 A (2) 14 A
 (3) 8 A (4) 10 A

Ans. (1)

Sol. All devices are in parallel so total current drawn is gives as

$$i_{\text{net}} = \frac{\text{Total Power}}{220}$$

$$i_{\text{net}} = \frac{15 \times 40 + 5 \times 100 + 5 \times 80 + 1000}{220}$$

$$i_{\text{net}} = \frac{2500}{220} \approx 11.36 \text{ A}$$

minimum capacity of main fuse should be more than 11.36 A

Ans is ≈ 12 A Hence (1)

11. A particle moves with simple harmonic motion in a straight line. In first τ s, after starting from rest it travels a distance a , and in next τ s it travels $2a$, in same direction, then :

- (1) Amplitude of motion is $4a$
- (2) Time period of oscillation is 6τ
- (3) Amplitude of motion is $3a$
- (4) Time period of oscillation is 8τ

Ans. (2)



$$x = A \sin(\omega t + \pi/2)$$

$$x = A \cos \omega t$$

$$A - a = A \cos \omega \tau \quad \cos \omega \tau = \frac{A - a}{A}$$

$$\cos 2 \omega \tau = \frac{A - 3a}{A}$$

$$2 \cos^2 \omega \tau - 1 = \frac{A - 3a}{A} = 2 \left(\frac{A - a}{A} \right)^2 - 1$$

$$2(A - a)^2 - A^2 = (A)(A - 3a)$$

$$2A^2 + 2a^2 - 4Aa - A^2 = A^2 - 3aA$$

$$2a^2 - 4Aa = -3aA$$

$$2a^2 = Aa$$

$$A = 2a$$

$$\cos \omega \tau = \frac{a}{2a} = \frac{1}{2}$$

$$\omega \tau = \frac{\pi}{3}$$

$$\frac{2\pi}{\omega} = T \quad T = \frac{2\pi \cdot 3\tau}{\pi}$$

$$T = 6\tau$$

12. The coercivity of a small magnet where the ferromagnet gets demagnetized is $3 \times 10^3 \text{ A m}^{-1}$. The current required to be passed in a solenoid of length 10 cm and number of turns 100, so that the magnet gets demagnetized when inside the solenoid, is :

- (1) 3A
- (2) 6 A
- (3) 30 mA
- (4) 60 mA

Ans. (1)

Sol. Coercivity = $\frac{B}{\mu_0} = 3 \times 10^3 = nI$
 $3 \times 10^3 = 1000 I$
 $I = 3A$

13. The forward biased diode connection is :

- (1)
- (2)
- (3)
- (4)

Ans. (3)

Sol. By convention

14. During the propagation of electromagnetic waves in a medium :

- (1) Electric energy density is equal to the magnetic energy density
- (2) Both electric magnetic energy densities are zero
- (3) Electric energy density is double of the magnetic energy density
- (4) Electric energy density is half of the magnetic energy density.

Ans. (1)

Sol. Factual question

15. In the circuit shown here, the point 'C' is kept connected to point 'A' till the current flowing through the circuit becomes constant. Afterward, suddenly, point 'C' is disconnected from point 'A' and connected to point 'B' at time $t = 0$. Ratio of the voltage across resistance and the inductor at $t = L/R$ will be equal to :

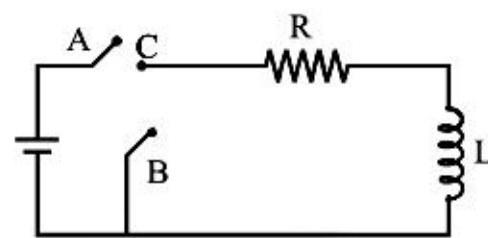

- (1) -1
- (2) $\frac{1-e}{e}$
- (3) $\frac{e}{1-e}$
- (4) 1

Ans. (1)

Sol. $V_R + V_L = 0$

$$\frac{V_R}{V_L} = -1$$

16. A mass 'm' is supported by a massless string wound around a uniform hollow cylinder of mass m and radius R. If the string does not slip on the cylinder, with what acceleration will the mass fall on release?

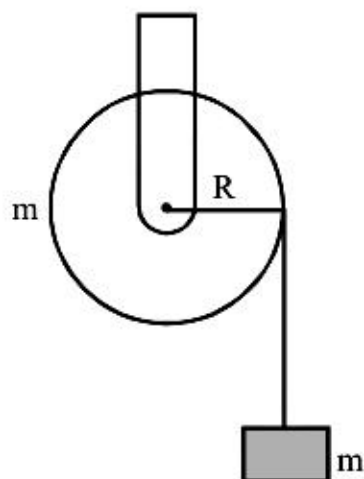

- (1) $\frac{5g}{6}$ (2) g (3) $\frac{2g}{3}$ (4) $\frac{g}{2}$

Ans. (4)

Sol. $mg - T = ma$

$$T \times R = \frac{mR^2}{2} \times \frac{a}{R}$$

$$\Rightarrow a = \frac{g}{2}$$

17. One mole of diatomic ideal gas undergoes a cyclic process ABC as shown in figure. The process BC is adiabatic. The temperatures at A, B and C are 400 K, 800 K and 600 K respectively. Choose the correct statement :

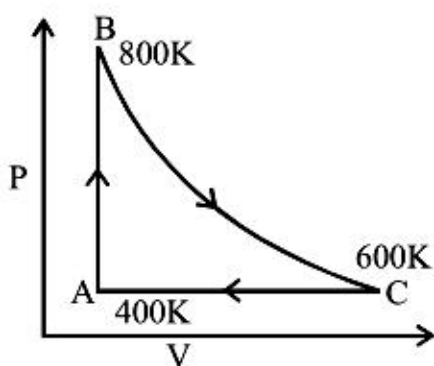

- (1) The change in internal energy in the process AB is $-350 R$.
 (2) The change in internal energy in the process BC is $-500R$
 (3) The change in internal energy in whole cyclic process is $250 R$.
 (4) The change in internal energy in the process CA is $700 R$.

Ans. (2)

Sol. Change in internal energy = $\frac{fnR\Delta T}{2}$

$$= \frac{5}{2} \times 1 \times R \times (-200)$$

$$= -500 R$$

18. From a tower of height H, a particle is thrown vertically upwards with a speed u. The time taken by the particle, to hit the ground, is n times that taken by it to reach the highest point of its path.

The relation between H, u and n is :

- (1) $2gH = nu^2(n - 2)$ (2) $gH = (n - 2)u^2$
 (3) $2gH = n^2u^2$ (4) $gH = (n - 2)^2u^2$

Ans. (1)

Sol. Time to reach highest point = $t = \frac{u}{g}$

time to reach ground = nt

$$S = ut + \frac{1}{2}at^2$$

$$-H = u(nt) - \frac{1}{2}g(nt)^2$$

$$\Rightarrow 2gH = nu^2(n - 2)$$

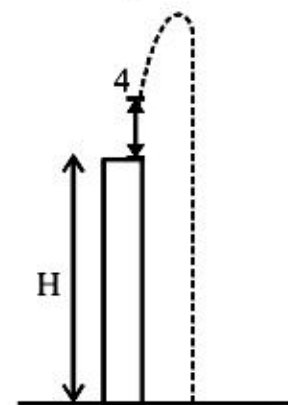

19. A thin convex lens made from crown glass

$\left(\mu = \frac{3}{2}\right)$ has focal length f. When it is measured in two different liquids having

refractive indices $\frac{4}{3}$ and $\frac{5}{3}$, it has the focal

length f_1 and f_2 respectively. The correct relation between the focal lengths is :

- (1) $f_2 > f$ and f_1 becomes negative
 (2) f_1 and f_2 both become negative
 (3) $f_1 = f_2 < f$
 (4) $f_1 > f$ and f_2 become negative

Ans. (4)

Sol. $\frac{1}{f} = \left(\frac{3/2}{1} - 1\right) \left(\frac{1}{R_1} - \frac{1}{R_2}\right)$ (1)

$\frac{1}{f_1} = \left(\frac{3/2}{4/3} - 1\right) \left(\frac{1}{R_1} - \frac{1}{R_2}\right)$ (2)

$\frac{1}{f_2} = \left(\frac{3/2}{5/3} - 1\right) \left(\frac{1}{R_1} - \frac{1}{R_2}\right)$ (3)

20. Three rods of Copper, Brass and Steel are welded together to form a Y-shaped structure. Area of cross-section of each rod = 4 cm². End of copper rod is maintained at 100°C where as ends of brass and steel are kept at 0°C. Lengths of the copper, brass and steel rods are 46, 13 and 12 cms respectively. The rods are thermally insulated from surroundings except at ends. Thermal conductivities of copper, brass and steel are 0.92, 0.26 and 0.12 CGS units respectively. Rate of heat flow through copper rod is :

- (1) 4.8 cal/s (2) 6.0 cal/s
 (3) 1.2 cal/s (4) 2.4 cal/s

Ans. (1)

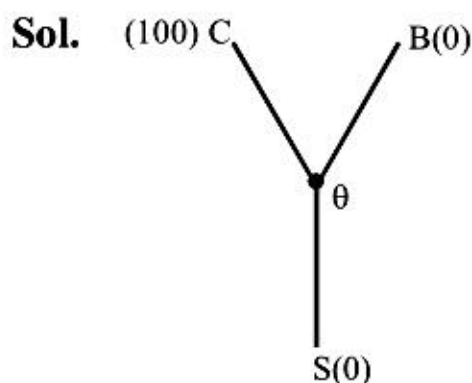

$$\frac{100 - \theta}{R_C} = \frac{\theta - 0}{R_B} + \frac{\theta - 0}{R_S}$$

where $R = \frac{\ell}{KA}$

on solving we get $\theta = 40$

Heat flow per unit time through copper rod

$$= \frac{(100 - 40)}{\ell_C} (K_C A_C)$$

$$= \frac{60}{46} \times 0.92 \times 4$$

$$= 4.8 \text{ cal/s}$$

21. A pipe of length 85 cm is closed from one end. Find the number of possible natural oscillations of air column in the pipe whose frequencies lie below 1250 Hz. The velocity of sound in air is 340 m/s.

- (1) 6 (2) 4
 (3) 12 (4) 8

Ans. (1)

Sol. Fundamental frequency of closed organ pipe

$$f_0 = \frac{v}{4\ell} = \frac{340}{4 \times 0.85} = 100 \text{ Hz}$$

So possible frequencies below 1250 Hz are 100 Hz, 300 Hz, 500 Hz, 700 Hz, 900 Hz, 1100 Hz

⇒ No. of frequencies = 6

22. There is a circular tube in a vertical plane. Two liquids which do not mix and of densities d_1 and d_2 are filled in the tube. Each liquid subtends 90° angle at centre. Radius joining their interface makes an angle α with vertical.

Ratio $\frac{d_1}{d_2}$ is :

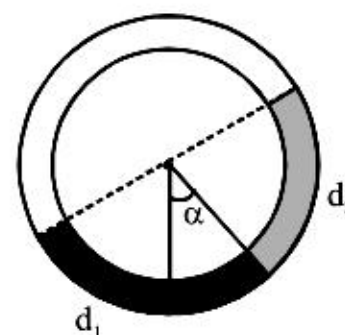

- (1) $\frac{1 + \tan \alpha}{1 - \tan \alpha}$ (2) $\frac{1 + \sin \alpha}{1 - \cos \alpha}$
 (3) $\frac{1 + \sin \alpha}{1 - \sin \alpha}$ (4) $\frac{1 + \cos \alpha}{1 - \cos \alpha}$

Ans. (1)

Sol.

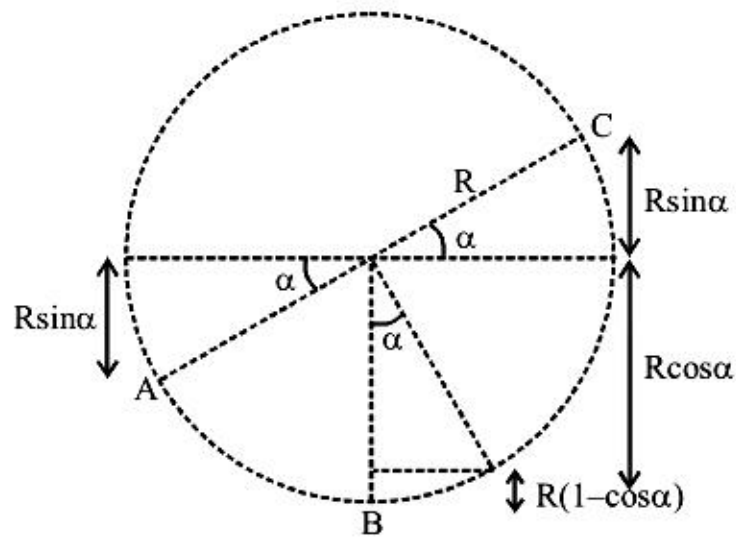

Let Radius of circular tube is R

Also $P_A = P_C = P_0$

Pressure at point B

$$P_B = P_0 + d_1(R - R \sin \alpha)g$$

$$= P_0 + d_2(R \sin \alpha + R \cos \alpha)g$$

$$\Rightarrow d_1(\cos \alpha - \sin \alpha) = d_2(\sin \alpha + \cos \alpha)$$

$$\frac{d_1}{d_2} = \frac{\cos \alpha + \sin \alpha}{\cos \alpha - \sin \alpha} = \frac{1 + \tan \alpha}{1 - \tan \alpha}$$

23. A green light is incident from the water to the air - water interface at the critical angle (θ). Select the **correct** statement.

- (1) The spectrum of visible light whose frequency is more than that of green light will come out to the air medium.
- (2) The entire spectrum of visible light will come out of the water at various angles to the normal
- (3) The entire spectrum of visible light will come out of the water at an angle of 90° to the normal.
- (4) The spectrum of visible light whose frequency is less than that of green light will come out to the air medium.

Ans. (4)

Sol. Frequency of light (ν) > frequency of green light (ν_G)

μ is also greater than μ_G and critical angle of light is less than green light therefore light will get total internal reflection and not come out to the air.

For frequency of light (ν) < ν_G ; light will not suffer T.I.R. Therefore light come out to the air

24. Hydrogen (${}_1\text{H}^1$), Deuterium (${}_1\text{H}^2$), singly ionised Helium (${}_2\text{He}^4$)⁺ and doubly ionised lithium (${}_3\text{Li}^6$)⁺⁺ all have one electron around the nucleus. Consider an electron transition from $n = 2$ to $n = 1$. If the wave lengths of emitted radiation are λ_1 , λ_2 , λ_3 and λ_4 respectively then approximately which one of the following is **correct** ?

- (1) $\lambda_1 = \lambda_2 = 4\lambda_3 = 9\lambda_4$
- (2) $\lambda_1 = 2\lambda_2 = 3\lambda_3 = 4\lambda_4$
- (3) $4\lambda_1 = 2\lambda_2 = 2\lambda_3 = \lambda_4$
- (4) $\lambda_1 = 2\lambda_2 = 2\lambda_3 = \lambda_4$

Ans. (1)

Sol. In Bohr model

$$\frac{1}{\lambda} = RZ^2 \left[\frac{1}{n_1^2} - \frac{1}{n_2^2} \right]$$

$$\Rightarrow \lambda \propto \frac{1}{Z^2}$$

$$\lambda_1 : \lambda_2 : \lambda_3 : \lambda_4 :: \frac{1}{1} : \frac{1}{1} : \frac{1}{4} : \frac{1}{9}$$

$$\Rightarrow \lambda_1 = \lambda_2 = 4\lambda_3 = 9\lambda_4$$

25. The radiation corresponding to $3 \rightarrow 2$ transition of hydrogen atom falls on a metal surface to produce photoelectrons. These electrons are made to enter a magnetic field of $3 \times 10^{-4}\text{T}$. If the radius of the largest circular path followed by these electrons is 10.0 mm, the work function of the metal is close to :-

- (1) 0.8 eV
- (2) 1.6 eV
- (3) 1.8 eV
- (4) 1.1 eV

Ans. (4)

Sol. In magnetic field, Radius $R = \frac{\sqrt{2m(\text{K.E.})}}{qB}$

$$\text{K.E.} = \frac{q^2 B^2 R^2}{2m}$$

$$\text{K.E.} = 0.80 \text{ eV}$$

Energy of photon for transition from $3 \rightarrow 2$ in hydrogen atom

$$E = 13.6 \left[\frac{1}{2^2} - \frac{1}{3^2} \right] = 1.88 \text{ eV}$$

From Einstein photoelectric equation

$$E = \text{K.E.}_{\text{max}} + \phi$$

$$\Rightarrow 1.88 = 0.8 + \phi \Rightarrow \phi = 1.08 \text{ eV}$$

$$\phi \approx 1.1 \text{ eV}$$

26. A block of mass m is placed on a surface with a vertical cross section given by $y = \frac{x^3}{6}$. If the coefficient of friction is 0.5, the maximum height above the ground at which the block can be placed without slipping is :-

- (1) $\frac{1}{3}m$ (2) $\frac{1}{2}m$ (3) $\frac{1}{6}m$ (4) $\frac{2}{3}m$

Ans. (3)

Sol.

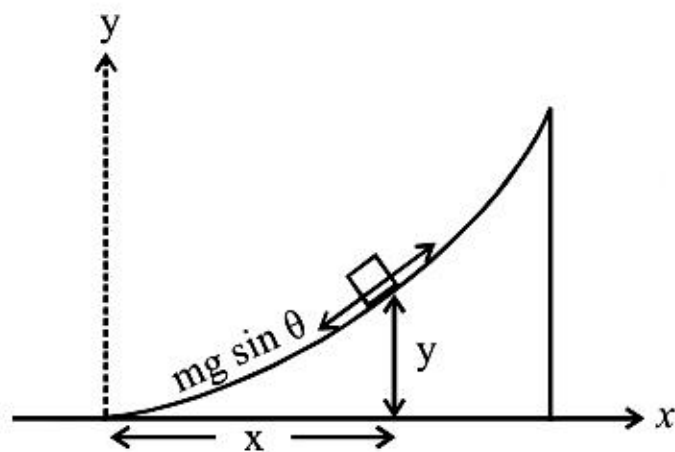

For equilibrium under limiting friction

$$mg \sin \theta = \mu mg \cos \theta$$

$$\Rightarrow \tan \theta = \mu$$

From the equation of surface $y = \frac{x^3}{6}$

$$\text{slope} = \frac{dy}{dx} = \frac{3x^2}{6} = \tan \theta$$

$$\Rightarrow \frac{x^2}{2} = \mu = 0.5 \Rightarrow x = 1$$

$$\text{So } y = \frac{1}{6}$$

27. When a rubber-band is stretched by a distance x , it exerts a restoring force of magnitude $F = ax + bx^2$ where a and b are constants. The work done in stretching the unstretched rubber-band by L is:-

(1) $\frac{aL^2}{2} + \frac{bL^3}{3}$

(2) $\frac{1}{2} \left(\frac{aL^2}{2} + \frac{bL^3}{3} \right)$

(3) $aL^2 + bL^3$

(4) $\frac{1}{2}(aL^2 + bL^3)$

Ans. (1)

Sol. Work done = $\int_0^L F dx$

$$= \int_0^L (ax + bx^2) dx$$

$$= \frac{aL^2}{2} + \frac{bL^3}{3}$$

28. On heating water, bubbles being formed at the bottom of the vessel detach and rise. Take the bubbles to be spheres of radius R and making a circular contact of radius r with the bottom of the vessel. If $r \ll R$, and the surface tension of water is T , value of r just before bubbles detach is:-

(density of water is ρ_w)

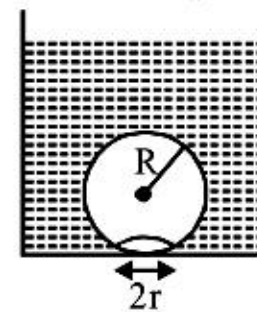

(1) $R^2 \sqrt{\frac{\rho_w g}{T}}$

(2) $R^2 \sqrt{\frac{3\rho_w g}{T}}$

(3) $R^2 \sqrt{\frac{\rho_w g}{3T}}$

(4) $R^2 \sqrt{\frac{\rho_w g}{6T}}$

Ans. (Bonus)

Sol.

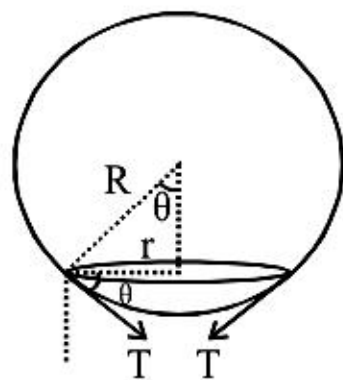

Force due to Surface Tension

$$= T (2\pi r) \sin \theta$$

$$= T (2\pi r) \times \frac{r}{R}$$

This force will balance the force of Bouyancy

$$T (2\pi r) \times \frac{r}{R} = \rho_w \times \frac{4}{3} \pi R^3 g$$

$$r = R^2 \sqrt{\frac{2\rho_w g}{3T}}$$

29. Two beams, A and B, of plane polarized light with mutually perpendicular planes of polarization are seen through a polaroid. From the position when the beam A has maximum intensity (and beam B has zero intensity), a rotation of polaroid through 30° makes the two beams appear equally bright. If the initial intensities of the two beams are I_A and I_B

respectively, then $\frac{I_A}{I_B}$ equals :

(1) 1 (2) $\frac{1}{3}$

(3) 3 (4) $\frac{3}{2}$

Ans. (2)

- Sol. When polaroid is at Angle 30° with beam A, it makes 60° with beam B

by malus law

$$I_A \cos^2 30^\circ = I_B \cos^2 60^\circ$$

$$\Rightarrow \frac{I_A}{I_B} = \frac{1}{3}$$

30. Assume that an electric field $\vec{E} = 30x^2 \hat{i}$ exists in space. Then the potential difference $V_A - V_O$, where V_O is the potential at the origin and V_A the potential at $x = 2$ m is :-

- (1) -80 J (2) 80 J
 (3) 120 J (4) -120 J

Ans. (1)

Sol. Given unit in options is wrong.

By using $dv = -\vec{E} \cdot \overline{dx}$

$$\Delta V = - \int \vec{E} \cdot \overline{dx}$$

$$V_A - V_0 = - \int_{x=0}^{x=2} 30x^2 dx = -10x^3 \Big|_{x=0}^{x=2}$$

$$V_A - V_0 = -10 [8 - 0] = -80 \text{ V}$$

31. The image of the line

$$\frac{x-1}{3} = \frac{y-3}{1} = \frac{z-4}{-5} \text{ in the plane}$$

$2x - y + z + 3 = 0$ is the line :

(1) $\frac{x+3}{3} = \frac{y-5}{1} = \frac{z-2}{-5}$

(2) $\frac{x+3}{-3} = \frac{y-5}{-1} = \frac{z+2}{5}$

(3) $\frac{x-3}{3} = \frac{y+5}{1} = \frac{z-2}{-5}$

(4) $\frac{x-3}{-3} = \frac{y+5}{-1} = \frac{z-2}{5}$

Ans. (1)

Sol. L : $\frac{x-1}{3} = \frac{y-3}{1} = \frac{z-4}{-5}$

P : $2x - y + z + 3 = 0$

It can be observed given line is parallel to given plane.

Image of (1, 3, 4) in given plane can be calculated as

$$\frac{x-1}{2} = \frac{y-3}{-1} = \frac{z-4}{1} = \frac{-2(2 \times 1 - 3 + 4 + 3)}{6} = -2$$

$$\Rightarrow x = -3 ; y = 5 ; z = 2$$

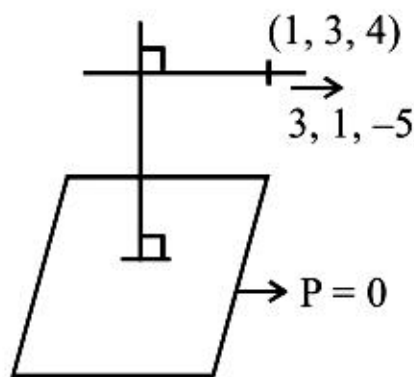

∴ Required line is

$$\frac{x+3}{3} = \frac{y-5}{1} = \frac{z-2}{-5}$$

32. If the coefficients of x^3 and x^4 in the expansion of $(1 + ax + bx^2)(1 - 2x)^{18}$ in powers of x are both zero, then (a, b) is equal to :-

(1) $\left(16, \frac{251}{3}\right)$ (2) $\left(14, \frac{251}{3}\right)$

(3) $\left(14, \frac{272}{3}\right)$ (4) $\left(16, \frac{272}{3}\right)$

Ans. (4)

Sol. In the expansion of $(1 + ax + bx^2)(1 - 2x)^{18}$

General term = $(1 + ax + bx^2) \cdot {}^{18}C_r (-2x)^r$

Coefficient of

$$x^3 = {}^{18}C_3(-2)^3 + a \cdot {}^{18}C_2(-2)^2 + b \cdot {}^{18}C_1(-2) = 0$$

Coefficient of

$$x^4 = {}^{18}C_4(-2)^4 + a \cdot {}^{18}C_3(-2)^3 + b \cdot {}^{18}C_2(-2)^2 = 0$$

on solving the equations we get

$$153a - 9b = 1632 \quad \dots(i)$$

$$3b - 32a = -240 \quad \dots(ii)$$

on solving we get $a = 16$ & $b = \frac{272}{3}$.

33. If $a \in \mathbb{R}$ and the equation

$$-3(x - [x])^2 + 2(x - [x]) + a^2 = 0$$

(where $[x]$ denotes the greatest integer $\leq x$) has no integral solution, then all possible values of a lie in the interval :

(1) $(-1, 0) \cup (0, 1)$ (2) $(1, 2)$

(3) $(-2, -1)$ (4) $(-\infty, -2) \cup (2, \infty)$

Ans. (1)

Sol. Given equation is

$$-3(x - [x])^2 + 2(x - [x]) + a^2 = 0$$

$$\Rightarrow a^2 = 3 \cdot \{x\}^2 - 2\{x\}$$

$$= 3 \cdot \left(\{x\} - \frac{1}{3}\right)^2 - \frac{1}{3} \quad (\because \{x\} \neq 0 \Rightarrow a^2 \neq 0)$$

$$\Rightarrow a^2 \in (0, 1)$$

$$\Rightarrow a \in (-1, 0) \cup (0, 1).$$

34. If $[\vec{a} \times \vec{b} \quad \vec{b} \times \vec{c} \quad \vec{c} \times \vec{a}] = \lambda [\vec{a} \vec{b} \vec{c}]^2$ then λ is equal to:

(1) 2 (2) 3 (3) 0 (4) 1

Ans. (4)

Sol. $[\vec{a} \times \vec{b} \quad \vec{b} \times \vec{c} \quad \vec{c} \times \vec{a}] = (\vec{a} \times \vec{b}) \cdot ((\vec{b} \times \vec{c}) \times (\vec{c} \times \vec{a}))$
 $= (\vec{a} \times \vec{b}) \cdot ([\vec{b} \vec{c} \vec{a}] \vec{c} - [\vec{b} \vec{c} \vec{c}] \vec{a})$
 $= [\vec{a} \vec{b} \vec{c}]^2$
 $\Rightarrow \lambda = 1.$

35. The variance of first 50 even natural numbers is:-

- (1) $\frac{833}{4}$ (2) 833 (3) 437 (4) $\frac{437}{4}$

Ans. (2)

Sol. We have to calculate variance of the data 2, 4, 6, 8, ..., 100

$$\sigma^2 = \frac{\sum x_i^2}{n} - \left(\frac{\sum x_i}{n} \right)^2$$

Now, $\sum x_i^2 = 2^2 + 4^2 + \dots + 100^2 = \frac{4 \cdot 50 \cdot 51 \cdot 101}{6}$

Now, $\frac{\sum x_i^2}{50} = 3434$

Also, $\left(\frac{\sum x_i}{n} \right)^2 = \left(\frac{2 \cdot 50 \cdot 51}{2 \cdot 50} \right)^2 = 2601$

$\therefore \sigma^2 = 3434 - 2601 = 833.$

36. A bird is sitting on the top of a vertical pole 20m high and its elevation from a point O on the ground is 45° . It flies off horizontally straight away from the point O. After one second, the elevation of the bird from O is reduced to 30° . Then the speed (in m/s) of the bird is :

- (1) $40(\sqrt{2}-1)$ (2) $40(\sqrt{3}-\sqrt{2})$
(3) $20\sqrt{2}$ (4) $20(\sqrt{3}-1)$

Ans. (4)

Sol. $OT = 20 = BT$
Now, In $\triangle OBL$

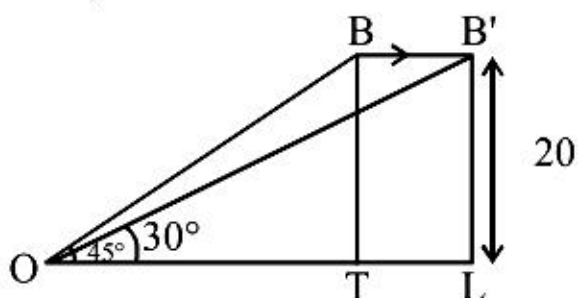

$$\tan 30^\circ = \frac{20}{20 + TL} = \frac{1}{\sqrt{3}}$$

$$\therefore TL = 20(\sqrt{3}-1)$$

$$\therefore \text{speed is } 20(\sqrt{3}-1) \text{ m/sec.}$$

37. The integral

$$\int_0^\pi \sqrt{1 + 4 \sin^2 \frac{x}{2} - 4 \sin \frac{x}{2}} dx \text{ equals :}$$

- (1) $\pi - 4$ (2) $\frac{2\pi}{3} - 4 - 4\sqrt{3}$
(3) $4\sqrt{3} - 4$ (4) $4\sqrt{3} - 4 - \frac{\pi}{3}$

Ans. (4)

Sol. $I = \int_0^\pi \left| 2 \sin \frac{x}{2} - 1 \right| dx = 2 \int_0^{\pi/2} |2 \sin x - 1| dx$

$$= 2 \left(\int_0^{\pi/6} (1 - 2 \sin x) dx + \int_{\pi/6}^{\pi/2} (2 \sin x - 1) dx \right)$$

$$= 2 \left(x + 2 \cos x \right)_0^{\pi/6} + \left(-2 \cos x - x \right)_{\pi/6}^{\pi/2}$$

$$= 4\sqrt{3} - 4 - \frac{\pi}{3}$$

38. The statement $\sim(p \leftrightarrow \sim q)$ is :

- (1) equivalent to $p \leftrightarrow q$
(2) equivalent to $\sim p \leftrightarrow q$
(3) a tautology
(4) a fallacy

Ans. (1)

Sol. Given statement is $\sim(p \leftrightarrow \sim q)$

As we know $\sim(p \leftrightarrow q) \equiv \sim p \leftrightarrow q$ or $p \leftrightarrow \sim q$

$$\therefore \sim(p \leftrightarrow \sim q) \equiv p \leftrightarrow q.$$

39. If A is an 3×3 non-singular matrix such that $AA' = A'A$ and $B = A^{-1} A'$, the BB' equals :

- (1) $I + B$ (2) I
(3) B^{-1} (4) $(B^{-1})'$

Ans. (2)

Sol. $B = A^{-1} A'$

$$\begin{aligned}
 B^T &= (A^{-1} A^T)^T = A (A^{-1})^T \\
 \therefore BB^T &= A^{-1} A^T A (A^{-1})^T \\
 &= A^{-1} AA^T (A^T)^{-1} (\because AA^T = A^T A) \\
 &= I
 \end{aligned}$$

40. The integral $\int \left(1+x - \frac{1}{x}\right) e^{x+\frac{1}{x}} dx$ is equal to :

- (1) $(x-1)e^{x+\frac{1}{x}} + c$ (2) $xe^{x+\frac{1}{x}} + c$
 (3) $(x+1)e^{x+\frac{1}{x}} + c$ (4) $-xe^{x+\frac{1}{x}} + c$

Ans. (2)

Sol. $\int \left(1+x - \frac{1}{x}\right) e^{x+\frac{1}{x}} dx$

$$\begin{aligned}
 &= \int \left(e^{x+\frac{1}{x}} + xe^{x+\frac{1}{x}} \left(1 - \frac{1}{x^2}\right) \right) dx \\
 &= \int (f(x) + x f'(x)) dx \quad (\text{where } f(x) = e^{x+\frac{1}{x}}) \\
 &= x \cdot e^{x+\frac{1}{x}} + c.
 \end{aligned}$$

41. If z is a complex number such that $|z| \geq 2$, then

the minimum value of $\left|z + \frac{1}{2}\right|$:

- (1) is equal to $\frac{5}{2}$
 (2) lies in the interval $(1, 2)$
 (3) is strictly greater than $\frac{5}{2}$
 (4) is strictly greater than $\frac{3}{2}$ but less than $\frac{5}{2}$

Ans. (2)

Sol. $\left|z + \frac{1}{2}\right| \geq \left||z| - \frac{1}{2}\right|$

Min. value of $\left|z + \frac{1}{2}\right|$ occurs at $|z| = 2$

$\therefore |z| \geq 2$

$\therefore \left|z + \frac{1}{2}\right|_{\text{Min}} = \left|2 - \frac{1}{2}\right| = \frac{3}{2}$

42. If g is the inverse of a function f and

$f'(x) = \frac{1}{1+x^5}$, then $g'(x)$ is equal to :

- (1) $1+x^5$ (2) $5x^4$
 (3) $\frac{1}{1+\{g(x)\}^5}$ (4) $1+\{g(x)\}^5$

Ans. (4)

Sol. $f(g(x)) = x$
 $\Rightarrow f'(g(x)) \cdot g'(x) = 1$

$\therefore g'(x) = \frac{1}{f'(g(x))} = 1 + \{g(x)\}^5$

43. If $\alpha, \beta \neq 0$, and $f(n) = \alpha^n + \beta^n$ and

$$\begin{vmatrix} 3 & 1+f(1) & 1+f(2) \\ 1+f(1) & 1+f(2) & 1+f(3) \\ 1+f(2) & 1+f(3) & 1+f(4) \end{vmatrix}$$

$= K(1-\alpha)^2(1-\beta)^2(\alpha-\beta)^2$, then K is equal to :

- (1) $\alpha\beta$ (2) $\frac{1}{\alpha\beta}$ (3) 1 (4) -1

Ans. (3)

Sol. $\begin{vmatrix} 3 & 1+\alpha+\beta & 1+\alpha^2+\beta^2 \\ 1+\alpha+\beta & 1+\alpha^2+\beta^2 & 1+\alpha^3+\beta^3 \\ 1+\alpha^2+\beta^2 & 1+\alpha^3+\beta^3 & 1+\alpha^4+\beta^4 \end{vmatrix}$

$$= \begin{vmatrix} 1 & 1 & 1 \\ 1 & \alpha & \beta \\ 1 & \alpha^2 & \beta^2 \end{vmatrix}^2 = (1-\alpha)^2(1-\beta)^2(\alpha-\beta)^2$$

$\therefore K = 1$

44. Let $f_K(x) = \frac{1}{K}(\sin^k x + \cos^k x)$ where $x \in \mathbb{R}$ and

$K \geq 1$. Then $f_4(x) - f_6(x)$ equals:

- (1) $\frac{1}{6}$ (2) $\frac{1}{3}$ (3) $\frac{1}{4}$ (4) $\frac{1}{12}$

Ans. (4)

Sol. $f_K(x) = \frac{1}{K}(\sin^K x + \cos^K x)$

\therefore

$$f_4(x) - f_6(x) = \frac{\sin^4 x + \cos^4 x}{4} - \frac{\sin^6 x + \cos^6 x}{6}$$

$$= \frac{1 - 2\sin^2 x \cos^2 x}{4} - \frac{1 - 3\sin^2 x \cos^2 x}{6}$$

$$= \frac{2}{24} = \frac{1}{12}$$

45. Let α and β be the roots of equation $px^2 + qx + r = 0$, $p \neq 0$. If p, q, r are in A.P. and

$\frac{1}{\alpha} + \frac{1}{\beta} = 4$, then the value of $|\alpha - \beta|$ is:

- (1) $\frac{\sqrt{61}}{9}$ (2) $\frac{2\sqrt{17}}{9}$ (3) $\frac{\sqrt{34}}{9}$ (4) $\frac{2\sqrt{13}}{9}$

Ans. (4)

Sol. $\frac{\alpha + \beta}{\alpha\beta} = 4 = -\frac{q}{r} \Rightarrow q = -4r$

$\therefore p, q$ & r are in A.P. $2q = p + r$
 $\Rightarrow -8r = p + r \Rightarrow p = -9r$

$$|\alpha - \beta| = \sqrt{(\alpha + \beta)^2 - 4\alpha\beta}$$

$$= \sqrt{\frac{q^2 - 4pr}{p^2}} = \sqrt{\frac{16r^2 + 36r^2}{p^2}}$$

$$= \sqrt{\frac{52r^2}{p^2}} = \sqrt{\frac{52}{81}} = \frac{2\sqrt{13}}{9}$$

46. Let A and B be two events such that

$P(\overline{A \cup B}) = \frac{1}{6}$, $P(A \cap B) = \frac{1}{4}$ and $P(\overline{A}) = \frac{1}{4}$,

Where \overline{A} stands for the complement of the event A . Then the events A and B are :

- (1) mutually exclusive and independent.
 (2) equally likely but not independent.
 (3) independent but not equally likely.
 (4) independent and equally likely.

Ans. (3)

Sol. $P(A \cup B) = 1 - P(\overline{A \cup B}) = \frac{5}{6}$

$\therefore P(A) + P(B) - P(A \cap B) = P(A \cup B)$

$\frac{3}{4} + P(B) - \frac{1}{4} = \frac{5}{6}$

$\therefore P(B) = \frac{1}{3}$

$\therefore P(A) = \frac{3}{4}$ & $P(B) = \frac{1}{3}$

$\therefore P(A) \cdot P(B) = \frac{1}{4} = P(A \cap B)$

$\therefore A$ & B are independent but not equally likely

47. If f and g are differentiable functions in $[0, 1]$ satisfying $f(0) = 2 = g(1)$, $g(0) = 0$ and $f(1) = 6$, then for some $c \in]0, 1[$:

- (1) $2f'(c) = g'(c)$ (2) $2f'(c) = 3g'(c)$
 (3) $f'(c) = g'(c)$ (4) $f'(c) = 2g'(c)$

Ans. (4)

Sol. Consider a function

$h(x) = f(x) - 2g(x)$

$\therefore h(0) = 2, h(1) = 2$

$\therefore h(x)$ is continuous and differentiable in $[0, 1]$

\therefore by Rolle's theorem, there exist at least one ' c ' such that

$h'(c) = 0$
 $= f'(c) = 2g'(c)$

48. Let the population of rabbits surviving at a time t be governed by the differential equation

$\frac{dp(t)}{dt} = \frac{1}{2}p(t) - 200$. If $p(0) = 100$, then $p(t)$ equals :

- (1) $400 - 300 e^{t/2}$ (2) $300 - 200 e^{-t/2}$
 (3) $600 - 500 e^{t/2}$ (4) $400 - 300 e^{-t/2}$

Ans. (1)

Sol. $\frac{dp(t)}{dt} = \frac{1}{2}p(t) - 200$

$$\int_{100}^{p(t)} \frac{dp(t)}{p(t) - 400} = \int_0^t \frac{dt}{2}$$

$$\Rightarrow \log \left| \frac{p(t) - 400}{-300} \right| = \frac{t}{2}$$

$$|P(t) - 400| = 300 e^{t/2}$$

$$400 - P(t) = 300 e^{t/2}$$

$$\therefore P(t) = 400 - 300e^{t/2}$$

49. Let C be the circle with centre at (1, 1) and radius = 1. If T is the circle centred at (0, y), passing through origin and touching the circle C externally, then the radius of T is equal to :

(1) $\frac{\sqrt{3}}{\sqrt{2}}$ (2) $\frac{\sqrt{3}}{2}$ (3) $\frac{1}{2}$ (4) $\frac{1}{4}$

Ans. (4)

Sol. $C_1 C_2 = r_1 + r_2$

$$\sqrt{1 + (1 - y)^2} = 1 + y$$

$$\therefore y = \frac{1}{4}$$

$$\therefore \text{radius} = \frac{1}{4}$$

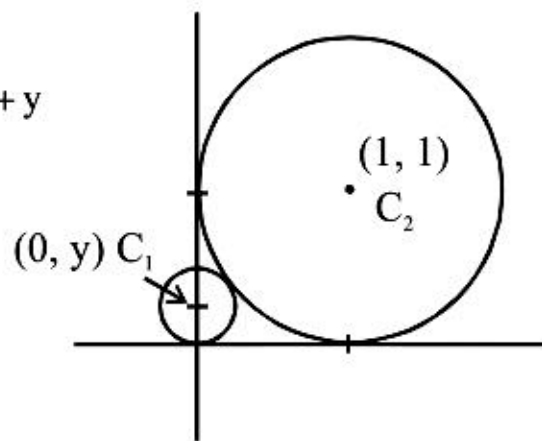

50. The area of the region described by $A = \{(x, y) : x^2 + y^2 \leq 1 \text{ and } y^2 \leq 1 - x\}$ is :

(1) $\frac{\pi}{2} + \frac{4}{3}$ (2) $\frac{\pi}{2} - \frac{4}{3}$

(3) $\frac{\pi}{2} - \frac{2}{3}$ (4) $\frac{\pi}{2} + \frac{2}{3}$

Ans. (1)

Sol. Shaded Area

$$= \frac{\pi}{2} + 2 \int_{y=0}^1 x \, dy$$

$$= \frac{\pi}{2} + 2 \int_0^1 (1 - y^2) \, dy$$

$$= \frac{\pi}{2} + 2 \left(1 - \frac{1}{3} \right)$$

$$= \frac{\pi}{2} + \frac{4}{3}$$

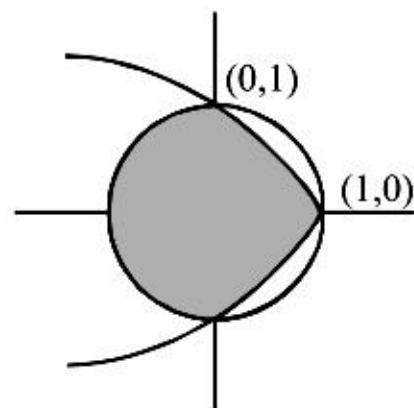

51. Let a, b, c and d be non-zero numbers. If the point of intersection of the lines $4ax + 2ay + c = 0$ and $5bx + 2by + d = 0$ lies in the fourth quadrant and is equidistant from the two axes then :

(1) $2bc - 3ad = 0$ (2) $2bc + 3ad = 0$

(3) $3bc - 2ad = 0$ (4) $3bc + 2ad = 0$

Ans. (3)

Sol. Put $y = -x$ [because equidistant points in fourth quadrant lies on $y = -x$]

$$4ax + 2ay + c = 0$$

$$\Rightarrow 4ax - 2ax + c = 0$$

$$\Rightarrow x = -\frac{c}{2a} \quad \dots(1)$$

$$5bx + 2by + d = 0$$

$$\Rightarrow 5bx - 2bx + d = 0$$

$$\Rightarrow 3bx + d = 0$$

$$\Rightarrow x = -\frac{d}{3b} \quad \dots(2)$$

from (1) & (2)

$$-\frac{c}{2a} = -\frac{d}{3b}$$

$$\Rightarrow 3bc - 2ad = 0$$

52. Let PS be the median of the triangle with vertices P (2, 2), Q (6, -1) and R (7, 3). The equation of the line passing through (1, -1) and parallel to PS is :

(1) $4x - 7y - 11 = 0$ (2) $2x + 9y + 7 = 0$

(3) $4x + 7y + 3 = 0$ (4) $2x - 9y - 11 = 0$

Ans. (2)

Sol. Slope of PS

$$M_{PS} = \frac{2-1}{2-\frac{13}{2}}$$

$$M_{PS} = -\frac{2}{9}$$

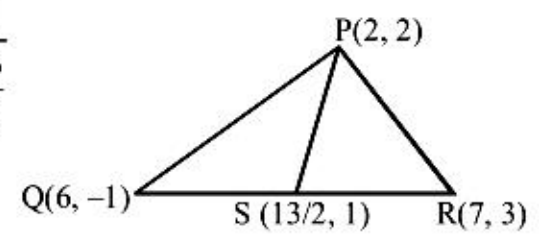

Equation of the line passing through (1, -1) and parallel to PS

$$y + 1 = -\frac{2}{9}(x - 1)$$

$$\Rightarrow 9y + 9 = -2x + 2$$

$$\Rightarrow 2x + 9y + 7 = 0$$

53. $\lim_{x \rightarrow 0} \frac{\sin(\pi \cos^2 x)}{x^2}$ is equal to:

- (1) $\frac{\pi}{2}$ (2) 1 (3) $-\pi$ (4) π

Ans. (4)

Sol. $\lim_{x \rightarrow 0} \frac{\sin(\pi \cos^2 x)}{x^2}$
 $\Rightarrow \lim_{x \rightarrow 0} \frac{\sin(\pi - \pi \sin^2 x)}{x^2}$
 $\Rightarrow \lim_{x \rightarrow 0} \frac{\sin(\pi \sin^2 x)}{\pi \sin^2 x} \times \pi \frac{\sin^2 x}{x^2}$
 $\Rightarrow \lim_{x \rightarrow 0} \frac{\sin(\pi \sin^2 x)}{\pi \sin^2 x} \times \pi \times \lim_{x \rightarrow 0} \left(\frac{\sin x}{x}\right)^2$
 $\Rightarrow 1 \times \pi \times 1$
 $= \pi$

54. If $X = \{4^n - 3n - 1 : n \in \mathbb{N}\}$ and $Y = \{9(n-1) : n \in \mathbb{N}\}$, where \mathbb{N} is the set of natural numbers, then $X \cup Y$ is equal to :

- (1) \mathbb{N} (2) $Y - X$ (3) X (4) Y

Ans. (4)

Sol. $X = 4^n - 3n - 1$
 $= (1 + 3)^n - 3n - 1$
 $= [{}^n C_0 3^0 + {}^n C_1 3^1 + {}^n C_2 3^2 + \dots + {}^n C_n 3^n] - 3n - 1$
 $= {}^n C_2 3^2 + {}^n C_3 3^3 + {}^n C_4 3^4 + \dots + {}^n C_n 3^n$
 $= 3^2 [{}^n C_2 + {}^n C_3 3^1 + {}^n C_4 3^2 + \dots + {}^n C_n 3^{n-2}]$
 $= 9 \times \text{integer (non negative) where } n \in \mathbb{N}$
 $= \text{multiple of 9 (non negative)}$
 $Y = 9(n-1) = \text{all non-negative multiple of 9 so}$
 $X \cup Y = Y$

55. The locus of the foot of perpendicular drawn from the centre of the ellipse $x^2 + 3y^2 = 6$ on any tangent to it is :

- (1) $(x^2 - y^2)^2 = 6x^2 + 2y^2$
 (2) $(x^2 - y^2)^2 = 6x^2 - 2y^2$
 (3) $(x^2 + y^2)^2 = 6x^2 + 2y^2$
 (4) $(x^2 + y^2)^2 = 6x^2 - 2y^2$

Ans. (3)

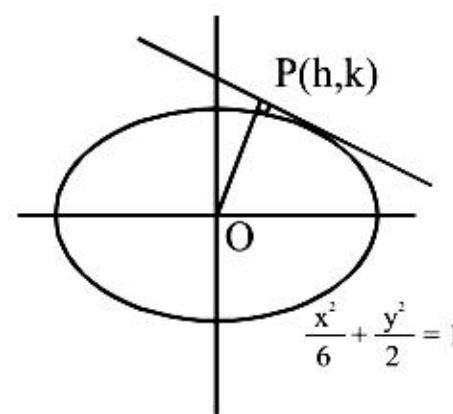

Sol.

Let the foot of perpendicular be (h, k)

then $m_{op} = \frac{k}{h}$

equation of tangent is

$$y = mx \pm \sqrt{a^2 m^2 + b^2}$$

$$y = mx \pm \sqrt{6m^2 + 2}$$

satisfied by (h, k) and $m = -\frac{1}{m_{op}} = -\frac{h}{k}$

$$\left(k + \frac{h^2}{k}\right)^2 = \frac{6h^2}{k^2} + 2$$

multiply by k^2

$$(k^2 + h^2)^2 = 6h^2 + 2k^2$$

$$\Rightarrow (x^2 + y^2)^2 = 6x^2 + 2y^2$$

56. Three positive numbers form an increasing G.P. If the middle term in this G.P. is doubled, the new numbers are in A.P. Then the common ratio of the G.P. is :

- (1) $\sqrt{2} + \sqrt{3}$ (2) $3 + \sqrt{2}$
 (3) $2 - \sqrt{3}$ (4) $2 + \sqrt{3}$

Ans. (4)

Sol. Let a, ar, ar^2 are in G.P.

$\therefore a, 2ar, ar^2$ are in AP

$$\Rightarrow 4ar = a + ar^2$$

$$\Rightarrow r^2 - 4r + 1 = 0$$

$$\Rightarrow r = 2 + \sqrt{3}, 2 - \sqrt{3}$$

Since GP is an increasing G.P

$$\Rightarrow r = 2 + \sqrt{3}$$

57. If $(10)^9 + 2(11)^1 (10)^8 + 3(11)^2 (10)^7 + \dots + 10 (11)^9 = k (10)^9$, then k is equal to :

(1) $\frac{121}{10}$ (2) $\frac{441}{100}$

(3) 100 (4) 110

Ans. (3)

Sol. $S = 10^9 + 2(11)^1 (10)^8 + 3(11)^2 (10)^7 + \dots + 10(11)^9$

$$\frac{11}{10}S = (11)(10)^8 + 2(11)^2 (10)^7 + \dots + 11^{10}$$

$$-\frac{S}{10} = 10^9 + (11 \cdot 10^8 + 11^2 \cdot 10^7 + \dots + 11^9) - 11^{10}$$

$$-\frac{S}{10} = 10^9 + 11 \cdot 10^8 \frac{\left(1 - \left(\frac{11}{10}\right)^9\right)}{\left(1 - \frac{11}{10}\right)} - 11^{10}$$

$$= 10^9 + 10^8 \cdot 11 \frac{(10^9 - 11^9)}{10^9(-1)} - 11^{10}$$

$$= 10^9 + 11(11^9 - 10^9) - 11^{10}$$

$$= 10^9(1 - 11)$$

$$S = 10^{11} = K \cdot 10^9$$

$$\Rightarrow K = 100$$

58. The angle between the lines whose direction cosines satisfy the equations $\ell + m + n = 0$ and $\ell^2 = m^2 + n^2$ is :

(1) $\frac{\pi}{3}$ (2) $\frac{\pi}{4}$ (3) $\frac{\pi}{6}$ (4) $\frac{\pi}{2}$

Ans. (1)

Sol. $\ell^2 = m^2 + n^2$... (1)

$$\ell + m + n = 0 \Rightarrow \ell = -(m + n) \dots (2)$$

$$(m + n)^2 = m^2 + n^2$$

$$mn = 0$$

Either $m = 0$ or $n = 0$

$$\text{for } m = 0, \ell = -n \Rightarrow \frac{\ell}{1} = \frac{m}{0} = \frac{n}{-1}$$

$$\text{//y for } n = 0, \ell = -m \Rightarrow \frac{\ell}{1} = \frac{m}{-1} = \frac{n}{0}$$

$$\Rightarrow \cos \theta = \frac{|1+0+0|}{\sqrt{2}\sqrt{2}} = \frac{1}{2}$$

$$\Rightarrow \theta = \frac{\pi}{3}$$

59. The slope of the line touching both, the parabolas $y^2 = 4x$ and $x^2 = -32y$ is :

(1) $\frac{1}{2}$ (2) $\frac{3}{2}$ (3) $\frac{1}{8}$ (4) $\frac{2}{3}$

Ans. (1)

Sol. Tangent to curve $y^2 = 4x$ is $y = mx + \frac{1}{m}$

... (1)

Tangent to curve $x^2 = -32y$ is $y = mx + 8m^2$

... (2)

On comparing (1) and (2)

$$m = \frac{1}{2}$$

60. If $x = -1$ and $x = 2$ are extreme points of $f(x) = \alpha \log |x| + \beta x^2 + x$ then :

(1) $\alpha = -6, \beta = \frac{1}{2}$

(2) $\alpha = -6, \beta = -\frac{1}{2}$

(3) $\alpha = 2, \beta = -\frac{1}{2}$

(4) $\alpha = 2, \beta = \frac{1}{2}$

Ans. (3)

Sol. $f(x) = \alpha \log |x| + \beta x^2 + x$

$$\Rightarrow f(x) = \frac{\alpha}{x} + 2\beta x + 1$$

$$\text{put } x = -1 \Rightarrow -\alpha - 2\beta + 1 = 0 \dots (1)$$

$$\text{put } x = 2 \Rightarrow \frac{\alpha}{2} + 4\beta + 1 = 0 \dots (2)$$

On solving (1) and (2)

$$\alpha = 2, \beta = -\frac{1}{2}$$

61. Which one of the following properties is **not** shown by NO ?

- (1) It combines with oxygen to form nitrogen dioxide
 (2) It's bond order is 2.5
 (3) It is diamagnetic in gaseous state
 (4) It is a neutral oxide

Ans. (3)

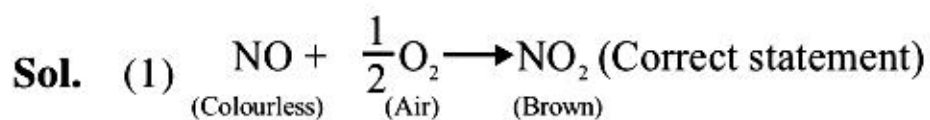

- (2) NO is odd e^- molecule which have B.O. = 2.5 (correct statment)
 (3) NO has an unpaired e^- in its antibonding M.O. \therefore it is paramagnetic compound (given statement in Q. is incorrect)
 (4) It is neutral towards litmus (correct statement)

62. If Z is a compressibility factor, van der Waals equation **at low** pressure can be written as :

- (1) $Z = 1 - \frac{Pb}{RT}$ (2) $Z = 1 + \frac{Pb}{RT}$
 (3) $Z = 1 + \frac{RT}{Pb}$ (4) $Z = 1 - \frac{a}{VRT}$

Ans. (4)

Sol. At low pressure, $V_m \rightarrow$ large
 $(V_m - b) \approx V_m$

$$\Rightarrow \left(P + \frac{a}{V_m^2} \right) V_m = RT$$

$$\Rightarrow PV_m + \frac{a}{V_m} = RT$$

$$\Rightarrow \frac{PV_m}{RT} + \frac{a}{V_m RT} = 1$$

$$\Rightarrow Z = \frac{PV_m}{RT} = 1 - \frac{a}{V_m RT}$$

63. The metal that cannot be obtained by electrolysis of an aqueous solution of its salts is:

- (1) Cu (2) Cr (3) Ag (4) Ca

Ans. (4)

Sol. (4) Ca is a reactive metal and extraction of reactive metal is not possible by electrolysis of aq. salt solution.

64. Resistance of 0.2 M solution of an electrolyte is 50Ω . The specific conductance of the solution is 1.4 S m^{-1} . The resistance of 0.5 M solution of the same electrolyte is 280Ω . The molar conductivity of 0.5 M solution of the electrolyte in $\text{S m}^2 \text{ mol}^{-1}$ is :

- (1) 5×10^3 (2) 5×10^2
 (3) 5×10^{-4} (4) 5×10^{-3}

Ans. (3)

Sol. $K = \frac{1}{R} \times \frac{\ell}{A}$

$$\frac{K_1}{K_2} = \frac{R_2}{R_1}$$

$$\frac{1.4}{K_2} = \frac{280}{50}$$

$$K_2 = \frac{7}{28} = \frac{1}{4} \text{ S m}^{-1}$$

$$\lambda_m = \frac{K}{M \times 1000} = \frac{1}{4} \times \frac{1}{0.5 \times 1000}$$

$$= 5 \times 10^{-4} \text{ S m}^2 \text{ mol}^{-1}$$

65. CsCl crystallises in body centred cubic lattice. if 'a' is its edge length then which of the following expression is **correct** :

- (1) $r_{\text{Cs}^+} + r_{\text{Cl}^-} = \frac{\sqrt{3}}{2}a$ (2) $r_{\text{Cs}^+} + r_{\text{Cl}^-} = \sqrt{3}a$
 (3) $r_{\text{Cs}^+} + r_{\text{Cl}^-} = 3a$ (4) $r_{\text{Cs}^+} + r_{\text{Cl}^-} = \frac{3a}{2}$

Ans. (1)

Sol. In CsCl crystal Cs^+ ion is present in cubic void therefore $r_{\text{Cs}^+} + r_{\text{Cl}^-} = \frac{\sqrt{3}a}{2}$

66. Consider separate solution of 0.500 M $\text{C}_2\text{H}_5\text{OH}(\text{aq})$, 0.100 M $\text{Mg}_3(\text{PO}_4)_2(\text{aq})$, 0.250 M $\text{KBr}(\text{aq})$ and 0.125 M $\text{Na}_3\text{PO}_4(\text{aq})$ at 25°C . Which statement is true about these solutions, assuming all salts to be strong electrolytes ?

- (1) 0.125 M $\text{Na}_3\text{PO}_4(\text{aq})$ has the highest osmotic pressure.
- (2) 0.500 M $\text{C}_2\text{H}_5\text{OH}(\text{aq})$ has the highest osmotic pressure.
- (3) They all have the same osmotic pressure.
- (4) 0.100 M $\text{Mg}_3(\text{PO}_4)_2(\text{aq})$ has the highest osmotic pressure.

Ans. (3)

Sol. $\pi = i C R T$

S.No.	Electrolyte	i	C	$i \times C$
1	$\text{C}_2\text{H}_5\text{OH}$	1	0.5M	0.5
2	$\text{Mg}_3(\text{PO}_4)_2$	5	0.1M	0.5
3	KBr	2	0.25M	0.5
4	Na_3PO_4	4	0.125M	0.5

\therefore all have same osmotic pressure.

67. In which of the following reaction H_2O_2 acts as a reducing agent ?

- (a) $\text{H}_2\text{O}_2 + 2\text{H}^+ + 2\text{e}^- \rightarrow 2\text{H}_2\text{O}$
- (b) $\text{H}_2\text{O}_2 - 2\text{e}^- \rightarrow \text{O}_2 + 2\text{H}^+$
- (c) $\text{H}_2\text{O}_2 + 2\text{e}^- \rightarrow 2\text{OH}^-$
- (d) $\text{H}_2\text{O}_2 + 2\text{OH}^- - 2\text{e}^- \rightarrow \text{O}_2 + 2\text{H}_2\text{O}$

- (1) (a), (c) (2) (b), (d)
- (3) (a), (b) (4) (c), (d)

Ans. (2)

Sol. A chemical species will act as reducing agent when it loses electron therefore correct options are (b) and (d).

68. In S_N^2 reactions, the correct order of reactivity for the following compounds :

CH_3Cl , $\text{CH}_3\text{CH}_2\text{Cl}$, $(\text{CH}_3)_2\text{CHCl}$ and $(\text{CH}_3)_3\text{CCl}$ is :

- (1) $\text{CH}_3\text{CH}_2\text{Cl} > \text{CH}_3\text{Cl} > (\text{CH}_3)_2\text{CHCl} > (\text{CH}_3)_3\text{CCl}$
- (2) $(\text{CH}_3)_2\text{CHCl} > \text{CH}_3\text{CH}_2\text{Cl} > \text{CH}_3\text{Cl} > (\text{CH}_3)_3\text{CCl}$
- (3) $\text{CH}_3\text{Cl} > (\text{CH}_3)_2\text{CHCl} > \text{CH}_3\text{CH}_2\text{Cl} > (\text{CH}_3)_3\text{CCl}$
- (4) $\text{CH}_3\text{Cl} > \text{CH}_3\text{CH}_2\text{Cl} > (\text{CH}_3)_2\text{CHCl} > (\text{CH}_3)_3\text{CCl}$

Ans. (4)

Sol. In S_N^2 reaction reactivity order for R-X with respect to 'R' follows $1^\circ > 2^\circ > 3^\circ$ which is based on less steric crowding which helps for ease of transition state formation.

$$\text{rate for } \text{S}_\text{N}^2 \propto \frac{1}{\text{Steric hindrance on C of C-LG}}$$

then correct order will be

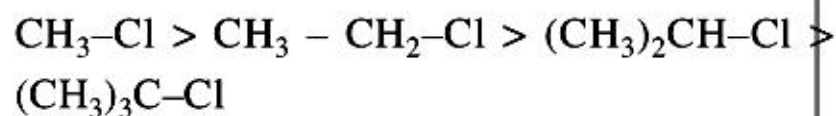

69. The octahedral complex of a metal ion M^{3+} with four monodentate ligands L_1 , L_2 , L_3 and L_4 absorb wavelength in the region of red, green, yellow and blue, respectively. The increasing order of ligand strength of the four ligands is:

- (1) $\text{L}_3 < \text{L}_2 < \text{L}_4 < \text{L}_1$ (2) $\text{L}_1 < \text{L}_2 < \text{L}_4 < \text{L}_3$
- (3) $\text{L}_4 < \text{L}_3 < \text{L}_2 < \text{L}_1$ (4) $\text{L}_1 < \text{L}_3 < \text{L}_2 < \text{L}_4$

Ans. (4)

Sol. The frequency order of given absorbed light is:
Blue > Green > Yellow > Red.

Respective L_4 L_2 L_3 L_1
ligands

Hence the ligand strength order is $\text{L}_4 > \text{L}_2 > \text{L}_3 > \text{L}_1$. Because strong field ligand causes higher splitting gap for octahedral-complex and absorbs high frequency light for d-d transition. Hence the answer is (4).

70. For the estimation of nitrogen, 1.4 g of an organic compound was digested by Kjeldahl method and the evolved ammonia was absorbed in 60 mL of $\frac{M}{10}$ sulphuric acid. The unreacted acid required 20 mL of $\frac{M}{10}$ sodium hydroxide for complete neutralization. The percentage of nitrogen in the compound is :
 (1) 3% (2) 5% (3) 6% (4) 10%

Ans. (4)

Sol. \therefore mass of organic compound = 1.4 gm

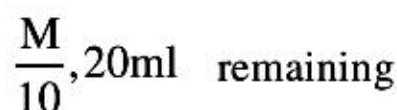
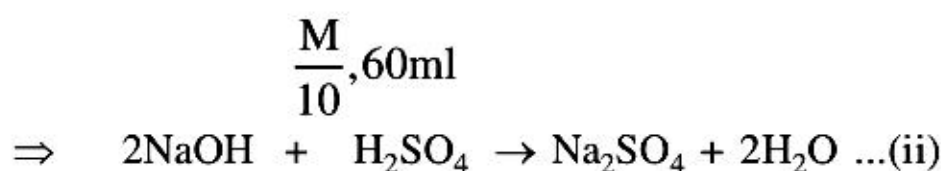
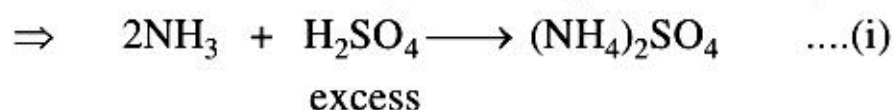

\Rightarrow m moles of remaining $\text{H}_2\text{SO}_4 = 1$
 m moles of $\text{NH}_3 = 2 \times$ m moles of H_2SO_4 used
 in reaction (i)
 $= 2 \times (6 - 1)$
 $= 10$

\Rightarrow moles of N = moles of $\text{NH}_3 = 10 \times 10^{-3}$

\Rightarrow mass of N = $\frac{1}{100} \times 14 = 0.14$ gm

\therefore % by mass of nitrogen = $\frac{0.14}{1.4} \times 100$
 $= 10\%$

71. The equivalent conductance of NaCl at concentration C and at infinite dilution are λ_C and λ_∞ , respectively. The correct relationship between λ_C and λ_∞ is given as :

(where the constant B is positive)

(1) $\lambda_C = \lambda_\infty - (B)\sqrt{C}$ (2) $\lambda_C = \lambda_\infty + (B)\sqrt{C}$

(3) $\lambda_C = \lambda_\infty + (B)C$ (4) $\lambda_C = \lambda_\infty - (B)C$

Ans. (1)

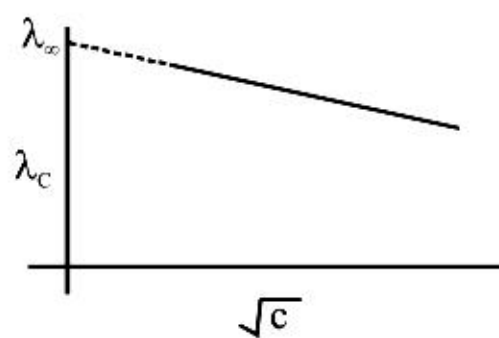

Sol.

$$\lambda_C = \lambda_\infty - B\sqrt{C}; \text{ Debye-Huckel equation}$$

72. For the reaction $\text{SO}_{2(g)} + \frac{1}{2}\text{O}_{2(g)} \rightleftharpoons \text{SO}_{3(g)}$, if $K_p = K_c (RT)^x$ where the symbols have usual meaning then the value of x is :
 (assuming ideality)

(1) $\frac{1}{2}$ (2) 1

(3) -1 (4) $-\frac{1}{2}$

Ans. (4)

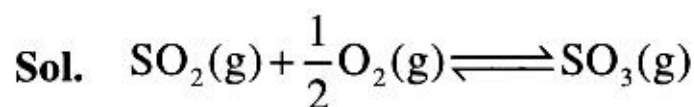

$$K_p = K_c (RT)^x$$

$$x = 1 - 1 - \frac{1}{2} = -\frac{1}{2}$$

73. In the reaction,
 CH_3COOH

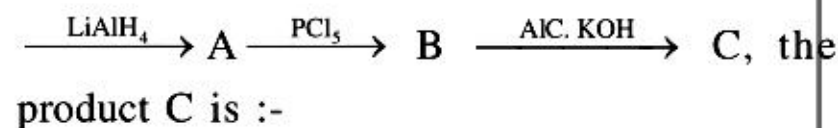

- (1) Ethylene (2) Acetyl chloride
 (3) Acetaldehyde (4) Acetylene

Ans. (1)

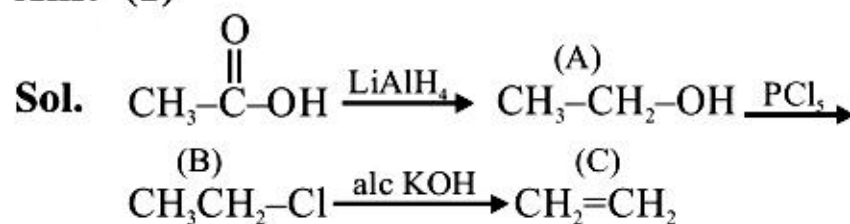

Reduction of CH_3COOH will produce $\text{CH}_3\text{CH}_2\text{OH}$ (A)
 Now reaction of $\text{CH}_3\text{CH}_2\text{OH}$ (A) with PCl_5 will produce $\text{CH}_3\text{CH}_2\text{Cl}$ (B).
 Now alcoholic KOH with Et-Cl will produce $\text{CH}_2=\text{CH}_2$ (C) Ethylene by E_2 elimination.
 Thus Ans. is (1) Ethylene.

74. Sodium phenoxide when heated with CO_2 under pressure at 125°C yields a product which on acetylation produces C.

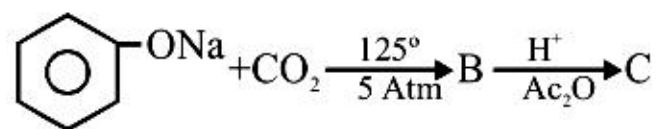

The major product C would be :

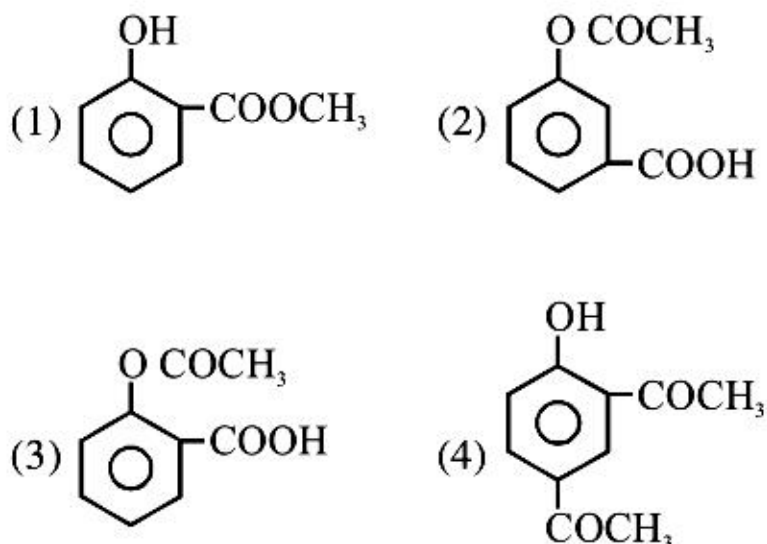

Ans. (3)

Sol. First step is carboxylation (Kolbe schmidt reaction) & second step is acetylation of sodium salt of aspirin (B) :-

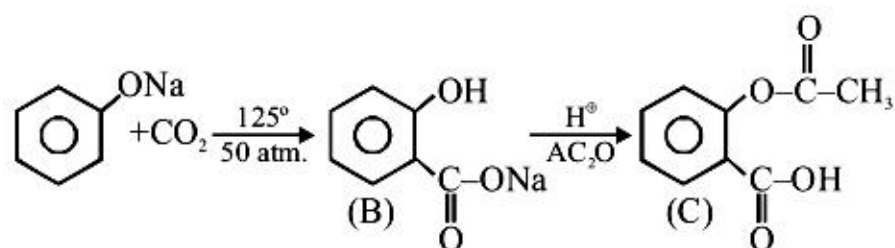

75. On heating an aliphatic primary amine with chloroform and ethanolic potassium hydroxide, the organic compound formed is :-

- (1) an alkyl cyanide
- (2) an alkyl isocyanide
- (3) an alkanol
- (4) an alkanediol

Ans. (2)

Sol. It is a carbyl amine reaction used for identification of primary amine also known as isocyanide test because of offensive smell of isocyanide.

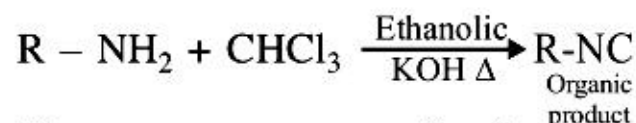

76. The correct statement for the molecule, CsI_3 , is:

- (1) it contains Cs^{3+} and I^- ions
- (2) it contains Cs^+ , I^- and lattice I_2 molecule
- (3) it is a covalent molecule
- (4) it contains Cs^+ and I_3^- ions

Ans. (4)

Sol. CsI_3 is an ionic compound and consisting of Cs^+ and I_3^- .

77. The equation which is balanced and represents the correct product (s) is :

- (1) $[\text{Mg}(\text{H}_2\text{O})_6]^{2+} + (\text{EDTA})^{4-} \xrightarrow{\text{excess NaOH}} [\text{Mg}(\text{EDTA})]^{2-} + 6\text{H}_2\text{O}$
- (2) $\text{CuSO}_4 + 4\text{KCN} \rightarrow \text{K}_2[\text{Cu}(\text{CN})_4] + \text{K}_2\text{SO}_4$
- (3) $\text{Li}_2\text{O} + 2\text{KCl} \rightarrow 2\text{LiCl} + \text{K}_2\text{O}$
- (4) $[\text{CoCl}(\text{NH}_3)_5]^+ + 5\text{H}^+ \rightarrow \text{Co}^{2+} + 5\text{NH}_4^+ + \text{Cl}^-$

Ans. (4)

Sol. (1)

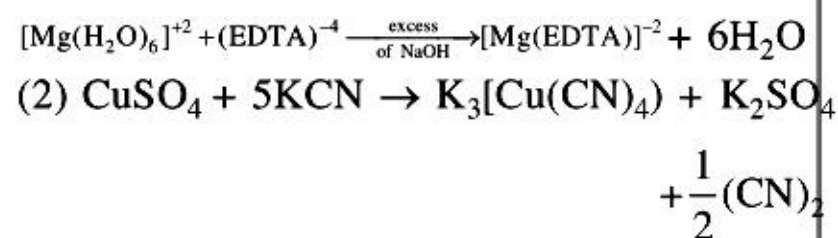

- (3) $2\text{LiCl} + \text{K}_2\text{O} \rightarrow \text{Li}_2\text{O} + 2\text{KCl}$

backward reaction of given equation is correct

- (4) $[\text{CoCl}(\text{NH}_3)_5]^+ + 5\text{H}^+ \rightarrow \text{Co}^{2+} + 5\text{NH}_4^+ + \text{Cl}^-$
Hence NH_3 gets protonated and makes Co^{2+} ion free in solution.

78. For which of the following molecule significant $\mu \neq 0$

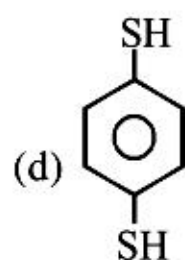
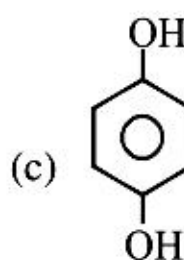
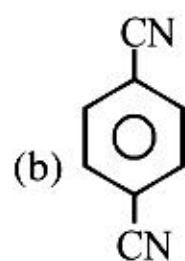
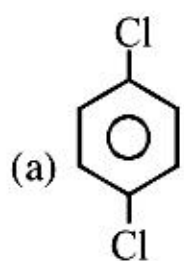

- (1) Only (c) (2) (c) and (d)
 (3) Only (a) (4) (a) and (b)

Ans. (2)

Sol. Due to presence of $\ell.p(s)$ on oxygen and sulphur

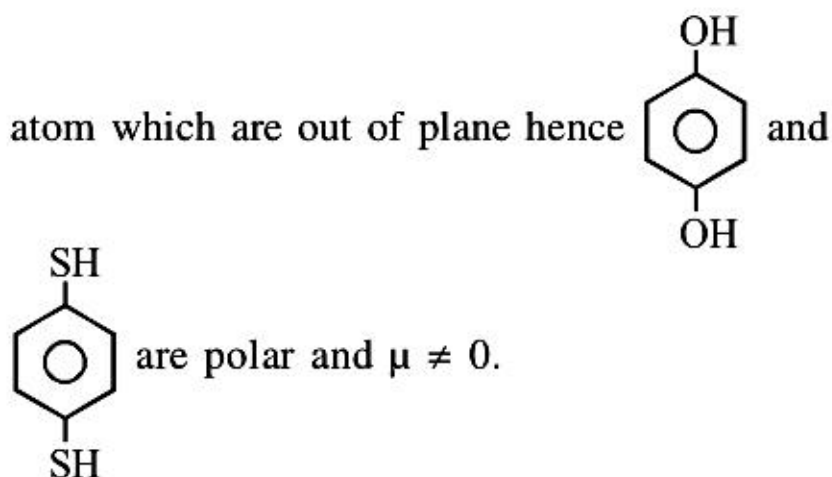

79. For the non-stoichiometre reaction $2A + B \rightarrow C + D$, the following kinetic data were obtained in three separate experiments, all at 298 K.

Initial Concentration (A)	Initial Concentration (B)	Initial rate of formation of C ($\text{mol L}^{-1}\text{S}^{-1}$)
0.1M	0.1M	1.2×10^{-3}
0.1M	0.2M	1.2×10^{-3}
0.2M	0.1M	2.4×10^{-3}

- (1) $\frac{dc}{dt} = k[A][B]^2$ (2) $\frac{dc}{dt} = k[A]$
 (3) $\frac{dc}{dt} = k[A][B]$ (4) $\frac{dc}{dt} = k[A]^2[B]$

Ans. (2)

Sol. Rate law -

$$r = k[A]^\alpha [B]^\beta$$

from table

$$1.2 \times 10^{-3} = k [0.1]^\alpha [0.1]^\beta \quad \dots(i)$$

$$1.2 \times 10^{-3} = k [0.1]^\alpha [0.2]^\beta \quad \dots(ii)$$

$$2.4 \times 10^{-3} = k [0.2]^\alpha [0.1]^\beta \quad \dots(iii)$$

from (i) and (ii) $\Rightarrow \beta = 0$
 from (i) and (iii) $\Rightarrow \alpha = 1$
 \therefore rate law would be -
 $r = k[A]$

80. Which series of reactions correctly represents chemical relations related to iron and its compound?

- (1) $\text{Fe} \xrightarrow{\text{Cl}_2, \text{heat}} \text{FeCl}_3 \xrightarrow{\text{heat, air}} \text{FeCl}_2 \xrightarrow{\text{Zn}} \text{Fe}$
 (2) $\text{Fe} \xrightarrow{\text{O}_2, \text{heat}} \text{Fe}_3\text{O}_4 \xrightarrow{\text{CO}, 600^\circ\text{C}} \text{FeO} \xrightarrow{\text{CO}, 700^\circ\text{C}} \text{Fe}$
 (3) $\text{Fe} \xrightarrow{\text{dil H}_2\text{SO}_4} \text{FeSO}_4 \xrightarrow{\text{H}_2\text{SO}_4, \text{O}_2} \text{Fe}_2(\text{SO}_4)_2 \xrightarrow{\text{Heat}} \text{Fe}$
 (4) $\text{Fe} \xrightarrow{\text{O}_2, \text{heat}} \text{FeO} \xrightarrow{\text{dil H}_2\text{SO}_4} \text{FeSO}_4 \xrightarrow{\text{Heat}} \text{Fe}$

Ans. (2)

Sol. Ans. is (2) because all steps are correct as per information.

- (1) is wrong because $\text{FeCl}_3 \xrightarrow[\text{(in presence of air)}]{\Delta, 1/2 \text{O}_2} \text{FeOCl} + \text{Cl}_2 \uparrow$
 (3) is wrong because $\text{Fe}_2(\text{SO}_4)_3 \xrightarrow{\Delta} \text{Fe}_2\text{O}_3(s) + 3\text{SO}_3 \uparrow$
 (4) is wrong because $2\text{FeSO}_4 \xrightarrow{\Delta} \text{Fe}_2\text{O}_3(s) + \text{SO}_2 \uparrow + \text{SO}_3 \uparrow$

81. Considering the basic strength of amines in aqueous solution, which one has the smallest pK_b value ?

- (1) $(CH_3)_3N$ (2) $C_6H_5NH_2$
 (3) $(CH_3)_2NH$ (4) CH_3NH_2

Ans. (3)

Sol. Basicity order :

$(CH_3)_2NH > CH_3NH_2 > (CH_3)_3N > C_6H_5NH_2$
 (in aq medium)

pK_b order :

$(CH_3)_2NH < CH_3NH_2 < (CH_3)_3N < C_6H_5NH_2$
 smallest pK_b : $(CH_3)_2NH$

82. Which one of the following bases is **not** present in DNA ?

- (1) Cytosine (2) Thymine
 (3) Quinoline (4) Adenine

Ans. (3)

Sol. All cytosine, thymine and adenine are present in DNA. Only quinoline is not present in DNA.

83. The correct set of four quantum numbers for the valence electrons of rubidium atom ($Z = 37$) is:

- (1) $5, 1, 1, +\frac{1}{2}$ (2) $5, 0, 1, +\frac{1}{2}$
 (3) $5, 0, 0, +\frac{1}{2}$ (4) $5, 1, 0, +\frac{1}{2}$

Ans. (3)

Sol. $Z = 37$; $[Kr]5s^1$

$n = 5, \ell = 0, m = 0, s = +\frac{1}{2}$ or $-\frac{1}{2}$

84. The major organic compound formed by the reaction of 1, 1, 1-trichloroethane with silver powder is :-

- (1) 2-Butyne (2) 2-Butene
 (3) Acetylen (4) Ethene

Ans. (1)

Sol.

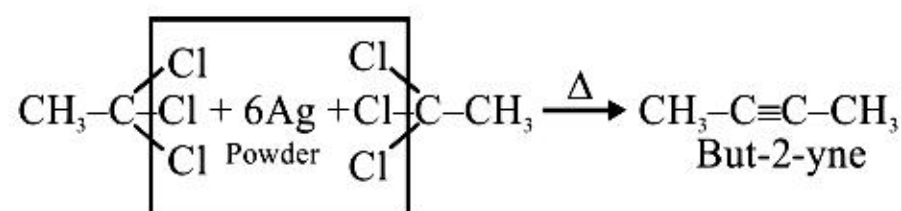

85. Given below are the half -cell reactions :-

$Mn^{2+} + 2e^- \rightarrow Mn$; $E^\circ = -1.18V$

$2(Mn^{3+} + e^- \rightarrow Mn^{2+})$; $E^\circ = +1.51 V$

The E° for $3Mn^{2+} \rightarrow Mn + 2Mn^{3+}$ will be :

- (1) $-0.33 V$; the reaction will not occur
 (2) $-0.33 V$; the reaction will occur
 (3) $-2.69 V$; the reaction will not occur
 (4) $-2.69 V$; the reaction will occur

Ans. (3)

Sol. $Mn^{2+} + 2e^- \rightarrow Mn$; $E^\circ = -1.18V$

$(Mn^{2+} \rightarrow Mn^{3+} + e^-) \times 2$; $E^\circ = -1.51V$

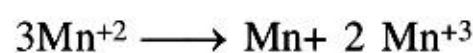

$$E^\circ_{cell} = -1.18 - 1.51$$

$$E^\circ_{cell} = -2.69 \text{ volt}$$

the reaction will not occur.

86. The ratio of masses of oxygen and nitrogen in a particular gaseous mixture is 1 : 4. The ratio of number of their molecule is :

- (1) 1 : 8 (2) 3 : 16 (3) 1 : 4 (4) 7 : 32

Ans. (4)

Sol. Given $\frac{W_{O_2}}{W_{N_2}} = \frac{1}{4}$

$$\Rightarrow \frac{n_{O_2}}{n_{N_2}} = \frac{W_{O_2} \times M_{N_2}}{W_{N_2} \times M_{O_2}}$$

$$= \frac{1}{4} \times \frac{28}{32} = \frac{7}{32}$$

87. Which one is classified as a condensation polymer?

- (1) Teflon (2) Acrylonitrile
(3) Dacron (4) Neoprene

Ans. (3)

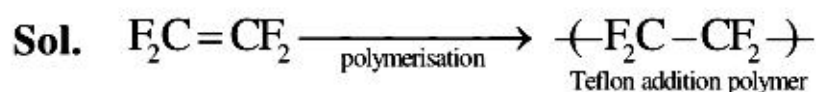

Acrylonitrile in monomeric unit.

Dacron is condensation polymer (Polyester).

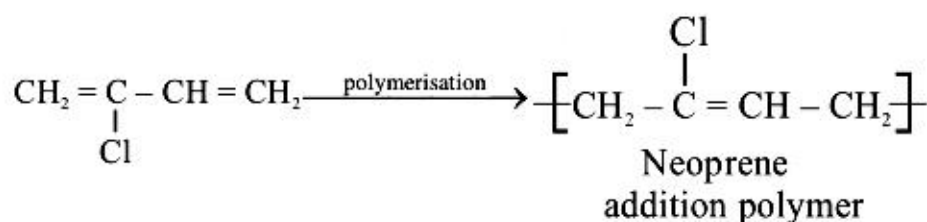
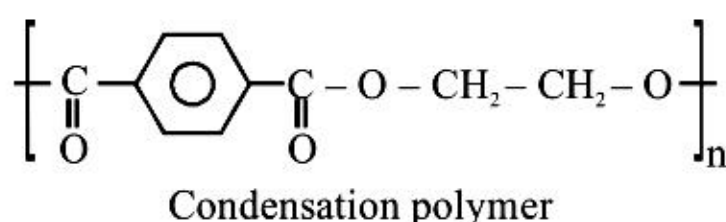
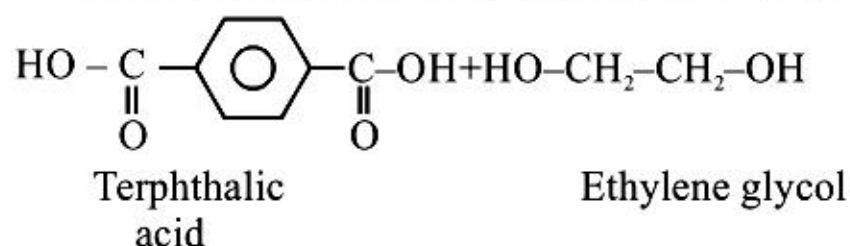

88. Among the following oxoacids, the correct decreasing order of acid strength is :-

- (1) $HClO_4 > HClO_3 > HClO_2 > HOCl$
(2) $HClO_2 > HClO_4 > HClO_3 > HOCl$
(3) $HOCl > HClO_2 > HClO_3 > HClO_4$
(4) $HClO_4 > HOCl > HClO_2 > HClO_3$

Ans. (1)

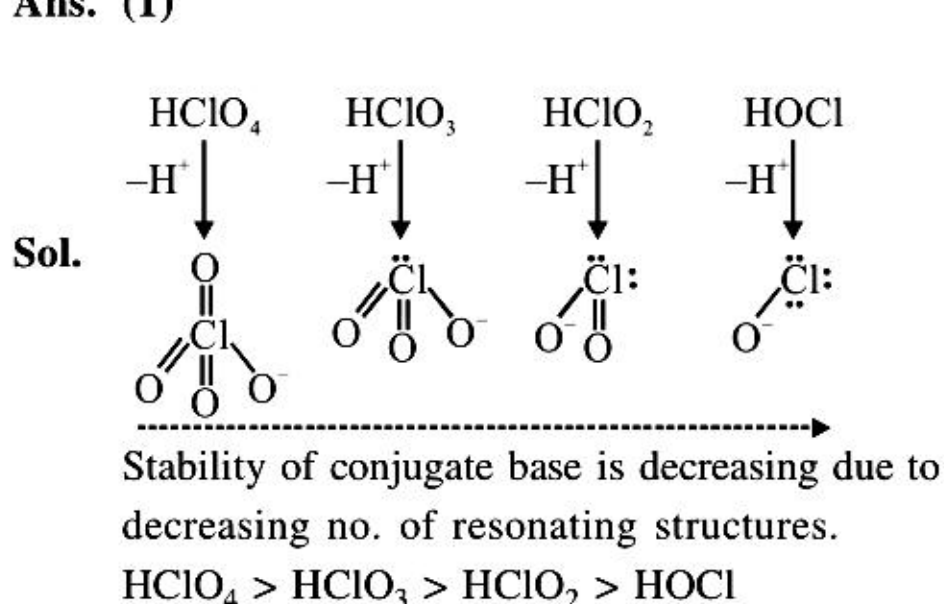

89. For complete combustion of ethanol, $C_2H_5OH(l) + 3O_2(g) \rightarrow 2CO_2(g) + 3H_2O(l)$, the amount of heat produced as measured in bomb calorimeter, is 1364.47 kJ mol⁻¹ at 25°C. Assuming ideality the Enthalpy of combustion, $\Delta_c H$, for the reaction will be :-

- (R = 8.314 kJ mol⁻¹)
(1) -1460.50 kJ mol⁻¹
(2) -1350.50 kJ mol⁻¹
(3) -1366.95 kJ mol⁻¹
(4) -1361.95 kJ mol⁻¹

Ans. (3)

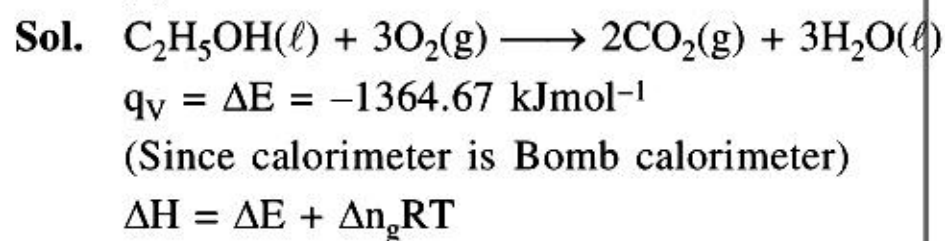

$$= -1364.67 + \frac{(-1)(8.314)(298)}{1000}$$

$$= -1364.67 + (-2.477)$$

$$\approx -1366.95 \text{ kJ/mol}$$

90. The most suitable reagent for the conversion of $R-CH_2-OH \rightarrow R-CHO$ is :-

- (1) CrO_3
(2) PCC (Pyridinium chlorochromate)
(3) $KMnO_4$
(4) $K_2Cr_2O_7$

Ans. (2)

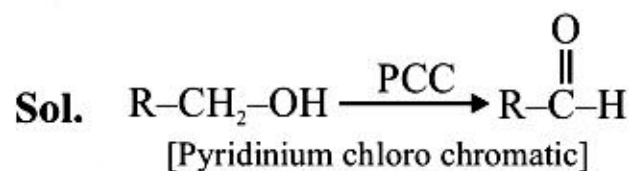

PCC is milder oxidising agent, oxidises only into aldehyde.