



Telangana State Council Higher Education

Notations :

- 1.Options shown in **green** color and with  icon are correct.
- 2.Options shown in **red** color and with  icon are incorrect.

Question Paper Name :	Electronics and Instrumentation Engineering 3rd Aug 2021 Shift1
Subject Name :	Electronics and Instrumentation Engineering
Creation Date :	2021-08-04 15:47:34
Duration :	180
Total Marks :	200
Display Marks:	No
Calculator :	None
Magnifying Glass Required? :	No
Ruler Required? :	No
Eraser Required? :	No
Scratch Pad Required? :	No
Rough Sketch/Notepad Required? :	No
Protractor Required? :	No
Show Watermark on Console? :	Yes
Highlighter :	No
Auto Save on Console? :	Yes

Electronics and Instrumentation Engineering

Group Number : 1

Group Id :	800894100
Group Maximum Duration :	0
Group Minimum Duration :	180
Show Attended Group? :	No
Edit Attended Group? :	No
Break time :	0
Group Marks :	200
Is this Group for Examiner? :	No

Mathematics

Section Id :	800894388
Section Number :	1
Section type :	Online
Mandatory or Optional :	Mandatory
Number of Questions :	50
Number of Questions to be attempted :	50
Section Marks :	50
Enable Mark as Answered Mark for Review and Clear Response :	Yes
Sub-Section Number :	1
Sub-Section Id :	800894442
Question Shuffling Allowed :	Yes

Question Number : 1 Question Id : 80089419846 Question Type : MCQ Option Shuffling : Yes
Display Question Number : Yes Is Question Mandatory : No Option Orientation : Vertical
Correct Marks : 1 Wrong Marks : 0

If $A = \begin{bmatrix} 1 & 0 & 0 \\ 1 & 0 & 1 \\ 0 & 1 & 0 \end{bmatrix}$, then $A^{50} =$

Options :

1. ✘ $\begin{bmatrix} 1 & 0 & 0 \\ 0 & 1 & 0 \\ 0 & 0 & 1 \end{bmatrix}$

2. ✔ $\begin{bmatrix} 1 & 0 & 0 \\ 25 & 1 & 0 \\ 25 & 0 & 1 \end{bmatrix}$

3. ✘ $\begin{bmatrix} 1 & 0 & 0 \\ 24 & 1 & 0 \\ 24 & 0 & 1 \end{bmatrix}$

4. ✘ $\begin{bmatrix} 1 & 0 & 0 \\ 50 & 1 & 0 \\ 50 & 0 & 1 \end{bmatrix}$

Question Number : 2 Question Id : 80089419847 Question Type : MCQ Option Shuffling : Yes

Display Question Number : Yes Is Question Mandatory : No Option Orientation : Vertical

Correct Marks : 1 Wrong Marks : 0

If $a + b + c = 0$, $\begin{vmatrix} ax & by & cz \\ bz & cx & ay \\ cy & az & bx \end{vmatrix} = k \begin{vmatrix} x & y & z \\ z & x & y \\ y & z & x \end{vmatrix} = abc(x^3 + y^3 + z^3) - xyz(a^3 + b^3 + c^3)$, then $k =$

Options :

1. ✘ xyz

2. ✔ abc

3. ✘ $x + y + z$

4. ✘ 0

Question Number : 3 Question Id : 80089419848 Question Type : MCQ Option Shuffling : Yes

Display Question Number : Yes Is Question Mandatory : No Option Orientation : Vertical

Correct Marks : 1 Wrong Marks : 0

Consider the statements with reference to the 3×3 matrices A and B and k is a constant .

I) $A = kB \Rightarrow |A| = k|B|$.

II) $\text{adj}(AB) = \text{adj}(B) \text{adj}(A)$.

III) for a matrix C, if $A=BC \Rightarrow C=B^{-1}A$

Which of the above statements are correct?

Options :

1. ✘ Only I and II are correct

2. ✔ Only II is correct

3. ✘ Only III is correct

4. ✘ Only II and III are correct

Question Number : 4 Question Id : 80089419849 Question Type : MCQ Option Shuffling : Yes

Display Question Number : Yes Is Question Mandatory : No Option Orientation : Vertical

Correct Marks : 1 Wrong Marks : 0

If the solution of the system of equations $x - y + z = 4, 2x + y - 3z = 0, x + y + z = 2$ is (x, y, z) ,

then $x+y+z=$

Options :

1. ✘ 0

2. ✘ 3

3. ✔ 2

4. ✘ 4

Question Number : 5 Question Id : 80089419850 Question Type : MCQ Option Shuffling : Yes

Display Question Number : Yes Is Question Mandatory : No Option Orientation : Vertical

Correct Marks : 1 Wrong Marks : 0

If $\frac{3x-2}{(x+1)(2x^2+3)} = \frac{A}{x+1} - \frac{Bx+C}{2x^2+3}$, then $A + B + C =$

Options :

1. ✘ 2

2. ✔ -4

3. ✘ 0

4. ✘ -2

Question Number : 6 Question Id : 80089419851 Question Type : MCQ Option Shuffling : Yes

Display Question Number : Yes Is Question Mandatory : No Option Orientation : Vertical

Correct Marks : 1 Wrong Marks : 0

If $y = \frac{a^x + a^{-x}}{2}$, $x > 0$ and $a > 1$ then $x =$

Options :

1. ✘ $\frac{a^y - a^{-y}}{2}$

2. ✓ $\log_a(y + \sqrt{y^2 - 1})$

3. ✘ $\log_a\left(\frac{y - \sqrt{y^2 - 1}}{2}\right)$

4. ✘ $\log_{1/a} y$

Question Number : 7 Question Id : 80089419852 Question Type : MCQ Option Shuffling : Yes

Display Question Number : Yes Is Question Mandatory : No Option Orientation : Vertical

Correct Marks : 1 Wrong Marks : 0

If $a^{2019-x} \cdot b^{2021x} = a^{x+2021} \cdot b^{2019x}$, then $x =$

Options :

1. ✘ $\log_{\left(\frac{b}{a}\right)} b$

2. ✘ $\log_{\left(\frac{a}{b}\right)} b$

3. ✓ $\log_{\left(\frac{b}{a}\right)} a$

4. ✘ $\log_{\left(\frac{a}{b}\right)} a$

Question Number : 8 Question Id : 80089419853 Question Type : MCQ Option Shuffling : Yes

Display Question Number : Yes Is Question Mandatory : No Option Orientation : Vertical

Correct Marks : 1 Wrong Marks : 0

If $\tan \theta = \frac{p}{q}$ then $\frac{p \sin \theta - q \cos \theta}{p \sin \theta + q \cos \theta} =$

Options :

1. ✘ $\frac{p-q}{p+q}$

2. ✘ $\frac{p^2 - q}{p + q^2}$

3. ✔ $\frac{p^2 - q^2}{p^2 + q^2}$

4. ✘ $\frac{2p}{p+q}$

Question Number : 9 Question Id : 80089419854 Question Type : MCQ Option Shuffling : Yes

Display Question Number : Yes Is Question Mandatory : No Option Orientation : Vertical

Correct Marks : 1 Wrong Marks : 0

If the area of a triangle is 75 sq.cm and two of its sides are 20 cm and 15 cm, then the included angle between the sides is

Options :

1. ✘ 60° or 120°

2. ✔ 30° or 150°

3. ✘ 45° or 135°

4. ✘ 90° or 135°

Question Number : 10 Question Id : 80089419855 Question Type : MCQ Option Shuffling : Yes

Display Question Number : Yes Is Question Mandatory : No Option Orientation : Vertical

Correct Marks : 1 Wrong Marks : 0

If $\cosh 2x = 99$, then $\coth x =$

Options :

1. ✘ $\frac{5}{7\sqrt{2}}$

2. ✔ $\frac{10}{7\sqrt{2}}$

3. ✘ $\frac{10}{2\sqrt{7}}$

4. ✘ $\frac{5}{2\sqrt{7}}$

Question Number : 11 Question Id : 80089419856 Question Type : MCQ Option Shuffling : Yes

Display Question Number : Yes Is Question Mandatory : No Option Orientation : Vertical

Correct Marks : 1 Wrong Marks : 0

A complex number 'z' having least modulus value and satisfying $|z - 2 + 2i| = 1$ is

Options :

1. ✘ $\left(2 - \frac{1}{\sqrt{2}}\right)(1 + i)$

2. ✘ $\left(2 + \frac{1}{\sqrt{2}}\right)(1 + i)$

3. ✔ $\left(2 - \frac{1}{\sqrt{2}}\right)(1 - i)$

4. ✘ $\left(2 + \frac{1}{\sqrt{2}}\right)(1 - i)$

Question Number : 12 Question Id : 80089419857 Question Type : MCQ Option Shuffling : Yes

Display Question Number : Yes Is Question Mandatory : No Option Orientation : Vertical

Correct Marks : 1 Wrong Marks : 0

If $\frac{(1+i)x-2i}{3+i} + \frac{(2-3i)y+i}{3-i} = 1$, then $x + y =$

Options :

1. ✘ $\frac{75}{67}$

2. ✘ $\frac{18}{37}$

3. ✘ $\frac{57}{35}$

4. ✔ $\frac{66}{23}$

Question Number : 13 Question Id : 80089419858 Question Type : MCQ Option Shuffling : Yes

Display Question Number : Yes Is Question Mandatory : No Option Orientation : Vertical

Correct Marks : 1 Wrong Marks : 0

$\left(\frac{\sqrt{3}+i}{2}\right)^6 + \left(\frac{\sqrt{3}-i}{2}\right)^6 =$

Options :

1. ✔ -2

2. ✘ -4

3. ✘ -6

4. ✘ -8

Question Number : 14 Question Id : 80089419859 Question Type : MCQ Option Shuffling : Yes

Display Question Number : Yes Is Question Mandatory : No Option Orientation : Vertical

Correct Marks : 1 Wrong Marks : 0

If the equation of the straight line $x + y + 1 = 0$ is changed into the form $x \cos \alpha + y \sin \alpha = p$, ($p > 0$), then $\alpha =$

Options :

1. ✘ $\frac{\pi}{4}$

2. ✘ $\frac{3\pi}{4}$

3. ✔ $\frac{5\pi}{4}$

4. ✘ $\frac{7\pi}{4}$

Question Number : 15 Question Id : 80089419860 Question Type : MCQ Option Shuffling : Yes

Display Question Number : Yes Is Question Mandatory : No Option Orientation : Vertical

Correct Marks : 1 Wrong Marks : 0

GCD of p, q, r is 1. If the line $px + qy + r = 0$ is passing through the point $(4,3)$ the sum of the intercepts

made by the line on the coordinate axes is 14, then a value of $p + q + r =$

Options :

1. ✘ -25

2. ✘ -23

3. ✔ -17

4. ✘ 31

Question Number : 16 Question Id : 80089419861 Question Type : MCQ Option Shuffling : Yes

Display Question Number : Yes Is Question Mandatory : No Option Orientation : Vertical

Correct Marks : 1 Wrong Marks : 0

The distance between the parallel lines $3x - 4y + 20 = 0, 3x - 4y + 5 = 0$ is

Options :

1. ✘ 15 units

2. ✘ 20 units

3. ✔ 3 units

4. ✘ 5 units

Question Number : 17 Question Id : 80089419862 Question Type : MCQ Option Shuffling : Yes

Display Question Number : Yes Is Question Mandatory : No Option Orientation : Vertical

Correct Marks : 1 Wrong Marks : 0

The distance between the centers of the two circles touching the coordinate axes and the line $3x + 4y = 12$ in the first quadrant is

Options :

1. ✘ $5\sqrt{3}$

2. ✘ $2\sqrt{5}$

3. ✘ $3\sqrt{5}$

4. ✔ $5\sqrt{2}$

Question Number : 18 Question Id : 80089419863 Question Type : MCQ Option Shuffling : Yes

Display Question Number : Yes Is Question Mandatory : No Option Orientation : Vertical

Correct Marks : 1 Wrong Marks : 0

The equation of a tangent to the circle $x^2 + y^2 - 2x + 8y - 23 = 0$ having slope 3 is

Options :

1. ✘ $6x - 2y + 25 = 0$

2. ✘ $3x - y + 27 = 0$

3. ✘ $3x - y + 23 = 0$

4. ✔ $3x - y + 13 = 0$

Question Number : 19 Question Id : 80089419864 Question Type : MCQ Option Shuffling : Yes

Display Question Number : Yes Is Question Mandatory : No Option Orientation : Vertical

Correct Marks : 1 Wrong Marks : 0

The interval in which the value of λ lies, if the line $3x - 4y = \lambda$ cuts the circle $x^2 + y^2 - 4x - 8y = 5$ at two points is

Options :

1. ✘ $(15, 35)$

2. ✘ (35, 15)

3. ✔ (-35, 15)

4. ✘ (-15, 35)

Question Number : 20 Question Id : 80089419865 Question Type : MCQ Option Shuffling : Yes

Display Question Number : Yes Is Question Mandatory : No Option Orientation : Vertical

Correct Marks : 1 Wrong Marks : 0

For $A \neq 0$ $\lim_{n \rightarrow \infty} \left(\frac{A + e^{nx}}{x + Ae^{nx}} \right) =$

Options :

1. ✘ 1, when $x > 0$

2. ✔ $\frac{A}{x}$, when $x < 0$

3. ✘ $\frac{A}{x}$, when $x > 0$

4. ✘ 0, when $x \in \mathbb{R}$

Question Number : 21 Question Id : 80089419866 Question Type : MCQ Option Shuffling : Yes

Display Question Number : Yes Is Question Mandatory : No Option Orientation : Vertical

Correct Marks : 1 Wrong Marks : 0

Let f be a differentiable function such that $f(x + y) = f(x) \cdot f(y), \forall x, y \in \mathbb{R}$. If $f'(0) = -3$ and $f(5) = 9$,

then $f'(5) =$

Options :

1. ✓ -27

2. ✗ 6

3. ✗ $-\frac{1}{3}$

4. ✗ -3

Question Number : 22 Question Id : 80089419867 Question Type : MCQ Option Shuffling : Yes

Display Question Number : Yes Is Question Mandatory : No Option Orientation : Vertical

Correct Marks : 1 Wrong Marks : 0

If $y = x^{-x}$ then $\frac{x d^2y}{y dx^2} + 1 =$

Options :

1. ✗ x

2. ✗ y^2

3. ✓ $y(1 + \log_e x)^2$

4. ✗ $(1 + \log_e x)$

Question Number : 23 Question Id : 80089419868 Question Type : MCQ Option Shuffling : Yes

Display Question Number : Yes Is Question Mandatory : No Option Orientation : Vertical

Correct Marks : 1 Wrong Marks : 0

The angle of intersection between the curves $x^2 + y^2 = 36\sqrt{2}$ and $x^2 - y^2 = 36$, is

Options :

1. ✘ $\frac{\pi}{6}$

2. ✔ $\frac{\pi}{4}$

3. ✘ $\frac{\pi}{3}$

4. ✘ $\frac{\pi}{12}$

Question Number : 24 Question Id : 80089419869 Question Type : MCQ Option Shuffling : Yes

Display Question Number : Yes Is Question Mandatory : No Option Orientation : Vertical

Correct Marks : 1 Wrong Marks : 0

If m is the slope of a tangent to the curve $e^y = 1 + x^2$, then

Options :

1. ✘ $|m| > 1$

2. ✘ $m > 1$

3. ✘ $m > -1$

4. ✔ $|m| \leq 1$

Question Number : 25 Question Id : 80089419870 Question Type : MCQ Option Shuffling : Yes

Display Question Number : Yes Is Question Mandatory : No Option Orientation : Vertical

Correct Marks : 1 Wrong Marks : 0

The maximum and minimum values of the function $f(x) = x^3 - 18x^2 + 96x + 4$ are M and

m respectively, then $M-m=$

Options :

1. ✓ 32

2. ✗ 22

3. ✗ 42

4. ✗ 52

Question Number : 26 Question Id : 80089419871 Question Type : MCQ Option Shuffling : Yes

Display Question Number : Yes Is Question Mandatory : No Option Orientation : Vertical

Correct Marks : 1 Wrong Marks : 0

If $u = \log\left(\frac{x^2+y^2}{x^5+y^5}\right)$, then $\left(x\frac{\partial u}{\partial x} + y\frac{\partial u}{\partial y}\right) =$

Options :

1. ✗ e^u

2. ✓ -2

3. ✗ $\log(u)$

4. ✗ 1

Question Number : 27 Question Id : 80089419872 Question Type : MCQ Option Shuffling : Yes

Display Question Number : Yes Is Question Mandatory : No Option Orientation : Vertical

Correct Marks : 1 Wrong Marks : 0

If $f(t) = 1 + t^2 + t^4 + t^6$, then $\int f(\tan x) dx =$

Options :

1. ✘ $x + \frac{(\tan x)^3}{3} + \frac{(\tan x)^5}{5} + \frac{(\tan x)^7}{7} + c$

2. ✔ $\tan x + \frac{(\tan x)^5}{5} + c$

3. ✘ $(\tan x)^2 + \frac{(\tan x)^5}{5} + c$

4. ✘ $\tan x + \frac{(\tan x)^3}{3} + \frac{(\tan x)^5}{5} + \frac{(\tan x)^7}{7} + c$

Question Number : 28 Question Id : 80089419873 Question Type : MCQ Option Shuffling : Yes

Display Question Number : Yes Is Question Mandatory : No Option Orientation : Vertical

Correct Marks : 1 Wrong Marks : 0

If $\int ((1+x)\sin x + (1-x)\cos x) dx = A(\sin x - \cos x) + f(x)(\sin x + \cos x) + C$, then $A f(x) =$

Options :

1. ✘ $3x$

2. ✘ $3 \sin x$

3. ✔ $-2x$

4. ✘ $2x + \sin x$

Question Number : 29 Question Id : 80089419874 Question Type : MCQ Option Shuffling : Yes

Display Question Number : Yes Is Question Mandatory : No Option Orientation : Vertical

Correct Marks : 1 Wrong Marks : 0

$$\text{If } \int x^5 e^{x^2} dx = \frac{1}{2} e^{x^2} f(x) + c \text{ then } f(2) =$$

Options :

1. ✘ 8

2. ✘ 9

3. ✔ 10

4. ✘ 12

Question Number : 30 Question Id : 80089419875 Question Type : MCQ Option Shuffling : Yes

Display Question Number : Yes Is Question Mandatory : No Option Orientation : Vertical

Correct Marks : 1 Wrong Marks : 0

$$\lim_{n \rightarrow \infty} \frac{1}{n} \left(\sin\left(\frac{1}{n}\right) + \sin\left(\frac{2}{n}\right) + \sin\left(\frac{3}{n}\right) + \dots + \sin(1) \right) =$$

Options :

1. ✘ $\cos(1)$

2. ✘ $\cos\left(\frac{1}{2}\right)$

3. ✔ $2\sin^2\left(\frac{1}{2}\right)$

4. ✘ $\log 2$

Question Number : 31 Question Id : 80089419876 Question Type : MCQ Option Shuffling : Yes

Display Question Number : Yes Is Question Mandatory : No Option Orientation : Vertical

Correct Marks : 1 Wrong Marks : 0

The area bounded by the curve $y = (x - 1)(x - 2)(x - 3)$ and x -axis lying between $x = 1$ and $x = 3$

is

Options :

1. ✘ $\frac{5}{2}$

2. ✘ $\frac{11}{2}$

3. ✔ $\frac{1}{2}$

4. ✘ $\frac{7}{4}$

Question Number : 32 Question Id : 80089419877 Question Type : MCQ Option Shuffling : Yes

Display Question Number : Yes Is Question Mandatory : No Option Orientation : Vertical

Correct Marks : 1 Wrong Marks : 0

The area of the region bounded by the curves $y = \sin x$ and $y = \cos x$, x -axis, $x=0$ and $x=\frac{\pi}{2}$ is

Options :

1. ✘ twice the area between $y = (\sin x - \cos x)$, x -axis, $x=0$ and $x=\frac{\pi}{4}$

2. ✘ equal to the area between $y = \sin x$, x -axis, $x=0$ and $x=\frac{\pi}{4}$

3. ✘

equal to the area between $y = (\sin x + \cos x)$, x-axis, $x=0$ and $x=\frac{\pi}{2}$

4. ✓ twice the area between $y = \sin x$, x-axis, $x=0$ and $x=\frac{\pi}{4}$

Question Number : 33 Question Id : 80089419878 Question Type : MCQ Option Shuffling : Yes

Display Question Number : Yes Is Question Mandatory : No Option Orientation : Vertical

Correct Marks : 1 Wrong Marks : 0

The value of a function f at different points are given in the following table

x	0	1	2	3	4	5	6
f(x)	0	1	1.414	1.732	2	2.236	2.449

The approximate value of $\int_0^6 f(x) dx =$

Options :

1. ✘ 8.516

2. ✓ 9.716

3. ✘ 9.125

4. ✘ 9.203

Question Number : 34 Question Id : 80089419879 Question Type : MCQ Option Shuffling : Yes

Display Question Number : Yes Is Question Mandatory : No Option Orientation : Vertical

Correct Marks : 1 Wrong Marks : 0

If p and q respectively are order and degree of the differential equation $y^2 \left(\frac{d^2y}{dx^2} \right) + 3x \left(\frac{dy}{dx} \right)^{\frac{1}{3}} = \sin x - x^2y^2$, then pq =

Options :

1. ✘ 2

2. ✔ 6

3. ✘ 15

4. ✘ 12

Question Number : 35 Question Id : 80089419880 Question Type : MCQ Option Shuffling : Yes

Display Question Number : Yes Is Question Mandatory : No Option Orientation : Vertical

Correct Marks : 1 Wrong Marks : 0

The equation of the curve passing through the origin and satisfying the differential equation $\frac{dy}{dx} = \frac{x-y}{x+y}$ is

Options :

1. ✔ $x^2 - y^2 - 2xy = 0$

2. ✘ $x^2 - y^2 + 2xy = 0$

3. ✘ $x^2 + y^2 - 2xy = 0$

4. ✘ $x^2 + y^2 + 2xy = 0$

Question Number : 36 Question Id : 80089419881 Question Type : MCQ Option Shuffling : Yes

Display Question Number : Yes Is Question Mandatory : No Option Orientation : Vertical

Correct Marks : 1 Wrong Marks : 0

The solution of the differential equation $\frac{dy}{dx} - ky = 0, y(0) = 1$, approach zero as $x \rightarrow \infty$, when

Options :

1. ✘ $k = 0$
2. ✘ $k > 0$
3. ✔ $k < 0$
4. ✘ k is any real number

Question Number : 37 Question Id : 80089419882 Question Type : MCQ Option Shuffling : Yes

Display Question Number : Yes Is Question Mandatory : No Option Orientation : Vertical

Correct Marks : 1 Wrong Marks : 0

The general solution of the differential equation $x \frac{dy}{dx} + y = x^3 y^6$ is

Options :

1. ✘ $(5x^3 - cx^5)y^5 = 2$
2. ✘ $(5x^5 - cx^3)y^5 = 2$
3. ✘ $(5x^5 + cx^3)y^5 = 2$
4. ✔ $(5x^3 + cx^5)y^5 = 2$

Question Number : 38 Question Id : 80089419883 Question Type : MCQ Option Shuffling : Yes

Display Question Number : Yes Is Question Mandatory : No Option Orientation : Vertical

Correct Marks : 1 Wrong Marks : 0

If the particular integral of $\frac{d^2y}{dx^2} - 6\frac{dy}{dx} + 13y = 8e^{3x} \sin 2x$ is equal to $f(x)$ times the particular

integral of $\frac{d^2y}{dx^2} + 4y = \sin 2x$, then $f(x) =$

Options :

1. ✘ e^{2x}
2. ✔ $8e^{3x}$
3. ✘ $8 \sin 2x$
4. ✘ $8e^{3x} \sin 2x$

Question Number : 39 Question Id : 80089419884 Question Type : MCQ Option Shuffling : Yes

Display Question Number : Yes Is Question Mandatory : No Option Orientation : Vertical

Correct Marks : 1 Wrong Marks : 0

The particular integral of $\frac{d^2y}{dx^2} + 4y = -4 \cos 2x$ is

Options :

1. ✔ $-x \sin 2x$
2. ✘ $\frac{-x \sin 2x}{2}$
3. ✘ $\frac{-x \cos 2x}{2}$
4. ✘ $-x \cos 2x$

Question Number : 40 Question Id : 80089419885 Question Type : MCQ Option Shuffling : Yes

Display Question Number : Yes Is Question Mandatory : No Option Orientation : Vertical

Correct Marks : 1 Wrong Marks : 0

The Laplace transform of the function $f(t) = |t - 1| + |t + 1|, t \geq 0$ is

Options :

1. ✘ $\frac{2}{s}(s + e^{-s})$

2. ✔ $\frac{2}{s^2}(s + e^{-s})$

3. ✘ $\frac{2}{s^2}(s - e^{-s})$

4. ✘ $\frac{2}{s}(s - e^{-s})$

Question Number : 41 Question Id : 80089419886 Question Type : MCQ Option Shuffling : Yes

Display Question Number : Yes Is Question Mandatory : No Option Orientation : Vertical

Correct Marks : 1 Wrong Marks : 0

If $L\{F(t)\} = \frac{2s+5}{s^2+2s-3}$ then $L\{F(2t)\} =$

Options :

1. ✔ $\frac{2s+10}{s^2+4s-12}$

2. ✘ $\frac{2s+10}{s^2+4s+12}$

3. ✘ $\frac{2s+10}{s^2+6s-12}$

4. ✘ $\frac{s+5}{s^2+4s-12}$

Question Number : 42 Question Id : 80089419887 Question Type : MCQ Option Shuffling : Yes

Display Question Number : Yes Is Question Mandatory : No Option Orientation : Vertical

Correct Marks : 1 Wrong Marks : 0

If $f(t) = \sin t + (\sin 2t - \sin t)u(t - \pi) + (\sin 3t - \sin 2t)u(t - 2\pi)$ where $u(t - a)$ is a unit step

function, then $f(t)$ when $\pi \leq t \leq 2\pi$ is

Options :

1. ✘ $\sin t$

2. ✔ $\sin 2t$

3. ✘ $\sin 3t$

4. ✘ $\sin t + \sin 2t$

Question Number : 43 Question Id : 80089419888 Question Type : MCQ Option Shuffling : Yes

Display Question Number : Yes Is Question Mandatory : No Option Orientation : Vertical

Correct Marks : 1 Wrong Marks : 0

The Laplace transform of $f(t) = \begin{cases} 0, & 0 < t \leq 1 \\ (t - 1), & 1 < t < 2 \\ 1, & t \geq 2 \end{cases}$

Options :

1. ✘

$$\frac{e^{-s}+e^{-2s}}{s^2}$$

2. ✘ $\frac{e^{-s}-e^{-2s}}{s}$

3. ✔ $\frac{e^{-s}-e^{-2s}}{s^2}$

4. ✘ $\frac{e^{-2s}-e^{-s}}{s^2}$

Question Number : 44 Question Id : 80089419889 Question Type : MCQ Option Shuffling : Yes
Display Question Number : Yes Is Question Mandatory : No Option Orientation : Vertical
Correct Marks : 1 Wrong Marks : 0

$$L^{-1}\left\{\frac{3s+1}{(s+1)^4}\right\} = e^{-t}F(t) \text{ then } F(1) =$$

Options :

1. ✘ $\frac{1}{6}$

2. ✘ $\frac{1}{3}$

3. ✔ $\frac{7}{6}$

4. ✘ $\frac{5}{6}$

Question Number : 45 Question Id : 80089419890 Question Type : MCQ Option Shuffling : Yes

Display Question Number : Yes Is Question Mandatory : No Option Orientation : Vertical

Correct Marks : 1 Wrong Marks : 0

If $L(f(t)) = \left\{ \frac{1}{(s+4)^{5/2}} \right\}$, then $f(t)$ is

Options :

1. ✓ $\frac{4}{3\sqrt{\pi}} e^{-4t} t^{3/2}$

2. ✗ $\frac{4}{3\sqrt{\pi}} t^{3/2}$

3. ✗ $\frac{4}{3\sqrt{\pi}} e^{4t} t^{3/2}$

4. ✗ $\frac{4}{3\sqrt{\pi}} e^{-4t} t^{5/2}$

Question Number : 46 Question Id : 80089419891 Question Type : MCQ Option Shuffling : Yes

Display Question Number : Yes Is Question Mandatory : No Option Orientation : Vertical

Correct Marks : 1 Wrong Marks : 0

If $y = y(t)$ satisfies the differential equation $y''' + 2y'' - y' - 2y = 0$ together with the conditions

$y(0) = y'(0) = 0, y''(0) = 3$, then the Laplace transform of $y(t)$ is equal to

Options :

1. ✗ $\frac{3}{(s^2-1)(s-2)}$

2. ✓ $\frac{3}{(s^2-1)(s+2)}$

3. ✘ $\frac{3}{(s^2+1)(s+2)}$

4. ✘ $\frac{3}{(s^2+1)(s-2)}$

Question Number : 47 Question Id : 80089419892 Question Type : MCQ Option Shuffling : Yes

Display Question Number : Yes Is Question Mandatory : No Option Orientation : Vertical

Correct Marks : 1 Wrong Marks : 0

Let $f(x) = e^{2x}$ in $(-\pi, \pi)$ and $f(x + 2\pi) = f(x), \forall x$. If the Fourier series expansion of the function is

$$f(x) = \sum_{n=0}^{\infty} (a_n \cos nx + b_n \sin nx) \text{ then } a_0 =$$

Options :

1. ✘ $\frac{\sinh 2\pi}{8\pi}$

2. ✘ $\frac{\sinh 2\pi}{\pi}$

3. ✘ $\frac{\sinh 2\pi}{4\pi}$

4. ✔ $\frac{\sinh 2\pi}{2\pi}$

Question Number : 48 Question Id : 80089419893 Question Type : MCQ Option Shuffling : Yes

Display Question Number : Yes Is Question Mandatory : No Option Orientation : Vertical

Correct Marks : 1 Wrong Marks : 0

If $f(x) = \begin{cases} 0, & \text{if } -\pi \leq x \leq 0 \\ \sin x, & \text{if } 0 \leq x \leq \pi \end{cases}$, $f(x + 2\pi) = f(x), \forall x$ and $f(x) = \sum_{n=0}^{\infty} (a_n \cos nx + b_n \sin nx)$, then

$$b_1 + b_2 + b_3 =$$

Options :

1. ✘ 0

2. ✘ -1

3. ✔ $\frac{1}{2}$

4. ✘ $\frac{1}{4}$

Question Number : 49 Question Id : 80089419894 Question Type : MCQ Option Shuffling : Yes

Display Question Number : Yes Is Question Mandatory : No Option Orientation : Vertical

Correct Marks : 1 Wrong Marks : 0

If $f(x)$ is periodic function defined on $-p \leq x \leq p$, then the coefficient of $\cos \frac{n\pi x}{p}$ in the Fourier series expansion of $f(x)$ is

Options :

1. ✘ $\frac{1}{p} \int_{-p}^p f(x) \cos nx dx$

2. ✘ $\frac{1}{2p} \int_{-p}^p f(x) \cos \frac{nx}{p} dx$

3. ✘ $\frac{2}{p} \int_0^p f(x) \cos \frac{n\pi x}{p} dx$

4. ✓ $\frac{1}{p} \int_{-p}^p f(x) \cos \frac{n\pi x}{p} dx$

Question Number : 50 Question Id : 80089419895 Question Type : MCQ Option Shuffling : Yes

Display Question Number : Yes Is Question Mandatory : No Option Orientation : Vertical

Correct Marks : 1 Wrong Marks : 0

If $f(x) = |\cos x|, x \in (-\pi, \pi)$ and $f(x) = \sum_{n=0}^{\infty} (a_n \cos nx + b_n \sin nx)$, then $a_0 + b_1 =$

Options :

1. ✗ $\frac{-4}{\pi^2}$

2. ✓ $\frac{2}{\pi}$

3. ✗ $\frac{4}{\pi}$

4. ✗ $\frac{-2}{\pi^2}$

Physics

Section Id :	800894389
Section Number :	2
Section type :	Online
Mandatory or Optional :	Mandatory
Number of Questions :	25
Number of Questions to be attempted :	25
Section Marks :	25
Enable Mark as Answered Mark for Review and	Yes

Clear Response :

Sub-Section Number : 1

Sub-Section Id : 800894443

Question Shuffling Allowed : Yes

Question Number : 51 Question Id : 80089419896 Question Type : MCQ Option Shuffling : Yes

Display Question Number : Yes Is Question Mandatory : No Option Orientation : Vertical

Correct Marks : 1 Wrong Marks : 0

The dimensional formulae of the following pair of physical quantities are same

Options :

1. ✘ Heat and Temperature

2. ✘ Work and Power

3. ✔ Work and Energy

4. ✘ Power and Energy

Question Number : 52 Question Id : 80089419897 Question Type : MCQ Option Shuffling : Yes

Display Question Number : Yes Is Question Mandatory : No Option Orientation : Vertical

Correct Marks : 1 Wrong Marks : 0

In the phenomenon of photo electric effect, the number of photo electrons emitted is proportional to

Options :

1. ✔ The intensity of radiation

2. ✘ The frequency of radiation

3. ✖ The velocity of incident radiation

4. ✖ The work-function of cathode material

Question Number : 53 Question Id : 80089419898 Question Type : MCQ Option Shuffling : Yes

Display Question Number : Yes Is Question Mandatory : No Option Orientation : Vertical

Correct Marks : 1 Wrong Marks : 0

The superconducting state is perfectly _____ in nature

Options :

1. ✔ Diamagnetic

2. ✖ Paramagnetic

3. ✖ Ferromagnetic

4. ✖ Non-magnetic

Question Number : 54 Question Id : 80089419899 Question Type : MCQ Option Shuffling : Yes

Display Question Number : Yes Is Question Mandatory : No Option Orientation : Vertical

Correct Marks : 1 Wrong Marks : 0

An ideal gas at temperature T is compressed through an isochoric process until its pressure is doubled
What is the final temperature

Options :

1. ✔ $2T$

2. ✘ $T/2$

3. ✘ T

4. ✘ $3T$

Question Number : 55 Question Id : 80089419900 Question Type : MCQ Option Shuffling : Yes

Display Question Number : Yes Is Question Mandatory : No Option Orientation : Vertical

Correct Marks : 1 Wrong Marks : 0

Match the following lists

List-I

- A. Isochoric process
- B. Isobaric process
- C. Isothermal process
- D. Adiabatic process

List-II

- i. Pressure remains constant
- ii. Temperature remains constant
- iii. Heat remains constant
- iv. Volume remains constant

Options :

1. ✘ A-i, B-ii, C-iii, D-iv

2. ✘ A-iv, B-ii, C-iii, D-i

3. ✘ A-iv, B-iii, C-ii, D-i

4. ✔ A-iv, B-i, C-ii, D-iii

Question Number : 56 Question Id : 80089419901 Question Type : MCQ Option Shuffling : Yes

Display Question Number : Yes Is Question Mandatory : No Option Orientation : Vertical

Correct Marks : 1 Wrong Marks : 0

The difference between two specific heats, C_p and C_v for a gas represents

Options :

1. ✘ Increase in kinetic energy of gas molecules
2. ✘ Increase in potential energy of gas molecules
3. ✔ External work done
4. ✘ Internal work done

**Question Number : 57 Question Id : 80089419902 Question Type : MCQ Option Shuffling : Yes
Display Question Number : Yes Is Question Mandatory : No Option Orientation : Vertical
Correct Marks : 1 Wrong Marks : 0**

Two vectors of equal magnitude R make an angle 60 degrees with each other. What is the magnitude of their resultant?

Options :

1. ✘ $R/\sqrt{2}$
2. ✘ $2\sqrt{2} R$
3. ✘ $\sqrt{2} R$
4. ✔ $\sqrt{3} R$

**Question Number : 58 Question Id : 80089419903 Question Type : MCQ Option Shuffling : Yes
Display Question Number : Yes Is Question Mandatory : No Option Orientation : Vertical
Correct Marks : 1 Wrong Marks : 0**

If \mathbf{i} and \mathbf{j} represent unit vectors in East and North directions, then the vector $\mathbf{i} - \mathbf{j}$ is in the direction of

Options :

1. ✘ North-East
2. ✘ North-West
3. ✔ South-East
4. ✘ South-West

Question Number : 59 Question Id : 80089419904 Question Type : MCQ Option Shuffling : Yes

Display Question Number : Yes Is Question Mandatory : No Option Orientation : Vertical

Correct Marks : 1 Wrong Marks : 0

If θ is the angle between two vectors \vec{a} and \vec{b} , then $|\vec{a} \cdot \vec{b}| = |\vec{a} \times \vec{b}|$, when θ is equal to

Options :

1. ✘ 0
2. ✔ $\frac{\pi}{4}$
3. ✘ $\frac{\pi}{2}$
4. ✘ π

Question Number : 60 Question Id : 80089419905 Question Type : MCQ Option Shuffling : Yes

Display Question Number : Yes Is Question Mandatory : No Option Orientation : Vertical

Correct Marks : 1 Wrong Marks : 0

A stone of mass 10 gm is horizontally thrown from a cliff of height 500 m with an initial velocity 100 m/s. Time taken to reach the ground. [Take $g = 10 \text{ m/s}^2$, and neglect air resistance].

Options :

1. ✘ $\sqrt{80}$ s
2. ✘ 40 s
3. ✘ 20 s
4. ✔ 10 s

Question Number : 61 Question Id : 80089419906 Question Type : MCQ Option Shuffling : Yes

Display Question Number : Yes Is Question Mandatory : No Option Orientation : Vertical

Correct Marks : 1 Wrong Marks : 0

The maximum height a football reaches if it is kicked with a velocity 40 m/s at an angle 30 degrees with the horizontal. (Take $g = 10 \text{ m/s}^2$)

Options :

1. ✘ 60 m
2. ✘ 40 m
3. ✔ 20 m
4. ✘ 10 m

Question Number : 62 Question Id : 80089419907 Question Type : MCQ Option Shuffling : Yes
Display Question Number : Yes Is Question Mandatory : No Option Orientation : Vertical
Correct Marks : 1 Wrong Marks : 0

Which of the following produces least friction?

Options :

1. ✘ Sliding friction
2. ✘ Composite friction
3. ✔ Rolling friction
4. ✘ Static friction

Question Number : 63 Question Id : 80089419908 Question Type : MCQ Option Shuffling : Yes
Display Question Number : Yes Is Question Mandatory : No Option Orientation : Vertical
Correct Marks : 1 Wrong Marks : 0

Two cars of unequal masses, having similar tyres, are moving on horizontal surface with the same initial speed. The minimum stopping distance is

Options :

1. ✘ smaller for lighter car
2. ✘ smaller for heavier car
3. ✘ depends on the volume of the car
4. ✔ same for both the cars

Question Number : 64 Question Id : 80089419909 Question Type : MCQ Option Shuffling : Yes
Display Question Number : Yes Is Question Mandatory : No Option Orientation : Vertical
Correct Marks : 1 Wrong Marks : 0

What is the work done by an engine which lifts a mass of 100 kg through a height of 10 cm

[Take $g = 10 \text{ m/s}^2$]

Options :

1. ✓ 100 J
2. ✗ 1000J
3. ✗ 10,000 J
4. ✗ 1 J

Question Number : 65 Question Id : 80089419910 Question Type : MCQ Option Shuffling : Yes
Display Question Number : Yes Is Question Mandatory : No Option Orientation : Vertical
Correct Marks : 1 Wrong Marks : 0

If a light body and a heavy body have equal momentum, then

Options :

1. ✓ The lighter body has greater energy than the heavier body
2. ✗ The lighter body has lesser kinetic energy than the heavier body
3. ✗ The kinetic energy of the lighter body is equal to the kinetic energy of the heavier body
4. ✗ The kinetic energy of both the bodies are independent of momentum

Question Number : 66 Question Id : 80089419911 Question Type : MCQ Option Shuffling : Yes

Display Question Number : Yes Is Question Mandatory : No Option Orientation : Vertical

Correct Marks : 1 Wrong Marks : 0

In simple harmonic motion, the restoring force must be proportional to

Options :

1. ✘ Amplitude

2. ✘ Frequency

3. ✘ Velocity

4. ✔ Displacement

Question Number : 67 Question Id : 80089419912 Question Type : MCQ Option Shuffling : Yes

Display Question Number : Yes Is Question Mandatory : No Option Orientation : Vertical

Correct Marks : 1 Wrong Marks : 0

The time period of the particle executing simple harmonic motion as per the equation

$$x = (25 \text{ m}) \sin [(2 \pi \text{ s}^{-1}) t + \pi / 2].$$

Options :

1. ✔ 1 s

2. ✘ 2 s

3. ✘ 3 s

4. ✘ 4 s

Question Number : 68 Question Id : 80089419913 Question Type : MCQ Option Shuffling : Yes

Display Question Number : Yes Is Question Mandatory : No Option Orientation : Vertical

Correct Marks : 1 Wrong Marks : 0

What is the length of a simple pendulum that has a period of 10 s ?

Options :

1. ✘ 24.84 cm

2. ✘ 2.484 cm

3. ✘ 2.484 m

4. ✔ 24.84 m

Question Number : 69 Question Id : 80089419914 Question Type : MCQ Option Shuffling : Yes

Display Question Number : Yes Is Question Mandatory : No Option Orientation : Vertical

Correct Marks : 1 Wrong Marks : 0

The intensity of sound is measured in the units of

Options :

1. ✘ Joule

2. ✘ Ampere

3. ✔ Decibel

4. ✘ Volt

Question Number : 70 Question Id : 80089419915 Question Type : MCQ Option Shuffling : Yes

Display Question Number : Yes Is Question Mandatory : No Option Orientation : Vertical

Correct Marks : 1 Wrong Marks : 0

According to Sabine the reverberation time is

Options :

1. ✓ Proportional to the volume of the hall and inversely proportional to the total absorption
2. ✗ Proportional to the total absorption and inversely proportional to the volume of the hall
3. ✗ Proportional to both volume of the hall and total absorption
4. ✗ Independent of volume of the hall and total absorption

Question Number : 71 Question Id : 80089419916 Question Type : MCQ Option Shuffling : Yes

Display Question Number : Yes Is Question Mandatory : No Option Orientation : Vertical

Correct Marks : 1 Wrong Marks : 0

When the deforming forces are removed, if a body remains in the deformed state and does not even partially regain its original shape it is called

Options :

1. ✗ Elastic body
2. ✗ Perfectly elastic body
3. ✓ Inelastic body

4. ✓ Plastic body

Note: For this question, ambiguity is found in question/answer. Candidate will get full marks for this question if any of the correct options are chosen.

Question Number : 72 Question Id : 80089419917 Question Type : MCQ Option Shuffling : Yes

Display Question Number : Yes Is Question Mandatory : No Option Orientation : Vertical

Correct Marks : 1 Wrong Marks : 0

The viscosity of a gas _____

Options :

1. ✗ Decreases with increase in temperature

2. ✓ Increases with increase in temperature

3. ✗ Is independent of temperature

4. ✗ is independent of pressure for very high pressure intensities

Question Number : 73 Question Id : 80089419918 Question Type : MCQ Option Shuffling : Yes

Display Question Number : Yes Is Question Mandatory : No Option Orientation : Vertical

Correct Marks : 1 Wrong Marks : 0

Ohm's law is not applicable to _____

Options :

1. ✗ DC circuits

2. ✗ High currents

3. ✘ Small resistors

4. ✔ Semiconductors

Question Number : 74 Question Id : 80089419919 Question Type : MCQ Option Shuffling : Yes

Display Question Number : Yes Is Question Mandatory : No Option Orientation : Vertical

Correct Marks : 1 Wrong Marks : 0

Assume that the current through resistor 50Ω in the given circuit is zero, the value of R is

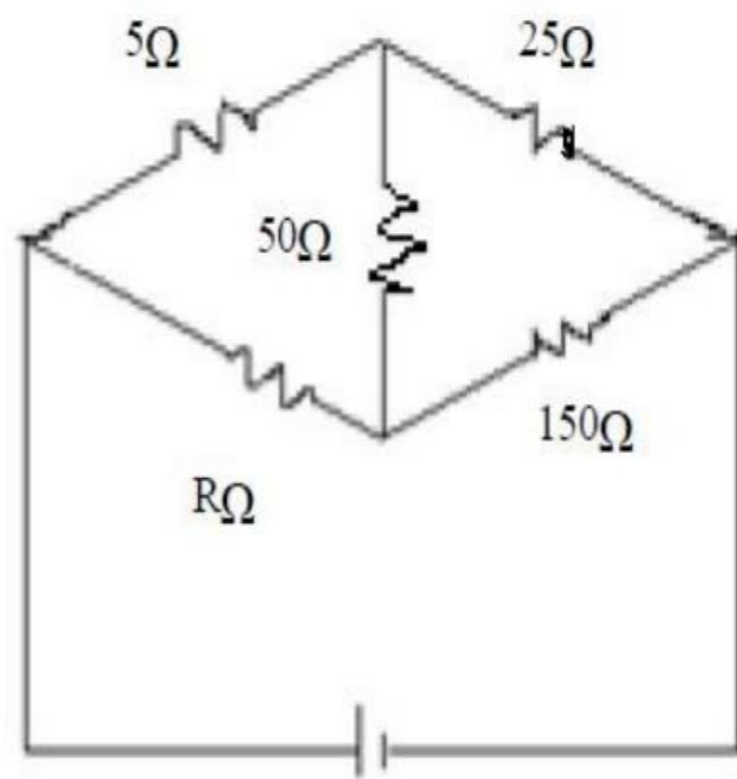

Options :

1. ✔ 30Ω

2. ✘ 40Ω

3. ✘ 50Ω

4. ✘ 100Ω

Question Number : 75 Question Id : 80089419920 Question Type : MCQ Option Shuffling : Yes

Display Question Number : Yes Is Question Mandatory : No Option Orientation : Vertical

Correct Marks : 1 Wrong Marks : 0

The force of attraction between the magnetic poles of strength m_1 and m_2 separated by a distance 'd' in free space is given by

Options :

1. ✘ $F = \frac{\mu}{4\pi} \frac{m_1 m_2}{d^2}$

2. ✔ $F = \frac{\mu_0}{4\pi} \frac{m_1 m_2}{d^2}$

3. ✘ $F = \frac{\mu_0}{2\pi} \frac{m_1 m_2}{d^2}$

4. ✘ $F = \frac{\mu_0}{4\pi} \frac{d^2}{m_1 m_2}$

Chemistry

Section Id :	800894390
Section Number :	3
Section type :	Online
Mandatory or Optional :	Mandatory
Number of Questions :	25
Number of Questions to be attempted :	25
Section Marks :	25
Enable Mark as Answered Mark for Review and Clear Response :	Yes
Sub-Section Number :	1
Sub-Section Id :	800894444

Question Shuffling Allowed :

Yes

Question Number : 76 Question Id : 80089419921 Question Type : MCQ Option Shuffling : Yes

Display Question Number : Yes Is Question Mandatory : No Option Orientation : Vertical

Correct Marks : 1 Wrong Marks : 0

According to Paulis exclusion principle, two electrons in the same orbital contains

Options :

1. ✘ Vertical spins

2. ✘ Angular spins

3. ✘ Same spins

4. ✔ Opposite spins

Question Number : 77 Question Id : 80089419922 Question Type : MCQ Option Shuffling : Yes

Display Question Number : Yes Is Question Mandatory : No Option Orientation : Vertical

Correct Marks : 1 Wrong Marks : 0

In the formation of nitrogen molecule, the number of electron pairs shared between the two nitrogen atoms is

Options :

1. ✘ Two

2. ✔ Three

3. ✘ One

4. ✘ Four

Question Number : 78 Question Id : 80089419923 Question Type : MCQ Option Shuffling : Yes

Display Question Number : Yes Is Question Mandatory : No Option Orientation : Vertical

Correct Marks : 1 Wrong Marks : 0

In the redox reaction of hypo and Iodine, the oxidation number of sulphur atom changes from

Options :

1. ✓ +2 to +2.5

2. ✗ +2.5 to +2.0

3. ✗ +2.0 to +3.0

4. ✗ +1.0 to +2.0

Question Number : 79 Question Id : 80089419924 Question Type : MCQ Option Shuffling : Yes

Display Question Number : Yes Is Question Mandatory : No Option Orientation : Vertical

Correct Marks : 1 Wrong Marks : 0

When the Phenol and water mixed together, the formed solution is called

Options :

1. ✗ Homogeneous

2. ✓ Heterogeneous

3. ✗ Colloidal

4. ✗ Azeotropic

Question Number : 80 Question Id : 80089419925 Question Type : MCQ Option Shuffling : Yes
Display Question Number : Yes Is Question Mandatory : No Option Orientation : Vertical
Correct Marks : 1 Wrong Marks : 0

How many grams of anhydrous oxalic acid is required to prepare one liter of 0.1 N oxalic acid solution?

Options :

1. ✘ 45 grams
2. ✘ 9.0 grams
3. ✔ 4.5 grams
4. ✘ 0.9 grams

Question Number : 81 Question Id : 80089419926 Question Type : MCQ Option Shuffling : Yes
Display Question Number : Yes Is Question Mandatory : No Option Orientation : Vertical
Correct Marks : 1 Wrong Marks : 0

If the sulphate ion concentration in a solution of $\text{Al}_2(\text{SO}_4)_3$ is 0.25 M, the concentration of $\text{Al}_2(\text{SO}_4)_3$ in the solution is

Options :

1. ✘ 0.250 M
2. ✘ 0.0625 M
3. ✔ 0.0833 M
4. ✘ 0.125M

Question Number : 82 Question Id : 80089419927 Question Type : MCQ Option Shuffling : Yes

Display Question Number : Yes Is Question Mandatory : No Option Orientation : Vertical

Correct Marks : 1 Wrong Marks : 0

Which of the following pair of species represent as conjugate Acid base?

Options :

1. ✘ HCl, H₂O

2. ✘ H₃PO₄, H₃O⁺

3. ✔ HSO₃⁻, SO₃²⁻

4. ✘ H₂CO₃, CO₂

Question Number : 83 Question Id : 80089419928 Question Type : MCQ Option Shuffling : Yes

Display Question Number : Yes Is Question Mandatory : No Option Orientation : Vertical

Correct Marks : 1 Wrong Marks : 0

From the following, choose the correct [H⁺] of a NaOH solution in M, if its pOH is 11.3

Options :

1. ✔ 2×10^{-3}

2. ✘ 2.7×10^{-3}

3. ✘ 2.7×10^{-12}

4. ✘ 6.2×10^{-8}

Question Number : 84 Question Id : 80089419929 Question Type : MCQ Option Shuffling : Yes

Display Question Number : Yes Is Question Mandatory : No Option Orientation : Vertical

Correct Marks : 1 Wrong Marks : 0

Hydrochloric acid is a strong acid. This means that _____.

Options :

1. ✓ HCl dissociates completely into $H^+(aq)$ and $Cl^-(aq)$ when it dissolves in water
2. ✗ HCl does not dissociate at all when it is dissolved in water
3. ✗ HCl produces a gaseous product when it is neutralized
4. ✗ HCl cannot be neutralized by a weak base

Question Number : 85 Question Id : 80089419930 Question Type : MCQ Option Shuffling : Yes

Display Question Number : Yes Is Question Mandatory : No Option Orientation : Vertical

Correct Marks : 1 Wrong Marks : 0

The impurities associated with mineral used in metallurgy are called

Options :

1. ✗ Flux
2. ✓ Gangue
3. ✗ Slag
4. ✗ Ore

Question Number : 86 Question Id : 80089419931 Question Type : MCQ Option Shuffling : Yes

Display Question Number : Yes Is Question Mandatory : No Option Orientation : Vertical

Correct Marks : 1 Wrong Marks : 0

German silver is an alloy of

Options :

1. ✘ Ag, Cu, Zn

2. ✘ Ag, Cu, Au

3. ✔ Cu, Zn, Ni

4. ✘ Cu, Zn, Fe

Question Number : 87 Question Id : 80089419932 Question Type : MCQ Option Shuffling : Yes

Display Question Number : Yes Is Question Mandatory : No Option Orientation : Vertical

Correct Marks : 1 Wrong Marks : 0

The degree of dissociation of weak electrolytes is

Options :

1. ✘ 100 %

2. ✘ $\geq 30\%$

3. ✘ $\leq 10\%$

4. ✔ $< 3\%$

Question Number : 88 Question Id : 80089419933 Question Type : MCQ Option Shuffling : Yes Display Question Number : Yes Is Question Mandatory : No Option Orientation : Vertical Correct Marks : 1 Wrong Marks : 0

With reference to Faraday's second law, the weights of different substances deposited by the passage of the same quantity of electricity, are proportional to their _____

Options :

1. ✓ Chemical equivalent weights
2. ✗ Current supply
3. ✗ Chemical equivalent density
4. ✗ Molecular Weights

Question Number : 89 Question Id : 80089419934 Question Type : MCQ Option Shuffling : Yes Display Question Number : Yes Is Question Mandatory : No Option Orientation : Vertical Correct Marks : 1 Wrong Marks : 0

A zinc rod is placed in 0.1M solution of zinc sulphate at 25°C. Assuming that the salt is dissociated to the extent of 95% at this dilution. The potential of the electrode at this temperature is ($E_{\text{Zn}^{2+}/\text{Zn}}^{\circ} = -0.76 \text{ V}$ and $\log 0.095 = -1.0223$).

Options :

1. ✗ -0.76 V
2. ✗ $+0.76 \text{ V}$
3. ✓ -0.79 V
4. ✗ $+0.79 \text{ V}$

Question Number : 90 Question Id : 80089419935 Question Type : MCQ Option Shuffling : Yes

Display Question Number : Yes Is Question Mandatory : No Option Orientation : Vertical

Correct Marks : 1 Wrong Marks : 0

Which of the following does not corrode when exposed to air?

Options :

1. ✘ Cu

2. ✔ Al

3. ✔ Ag

4. ✘ Fe

Note: For this question, ambiguity is found in question/answer. Candidate will get full marks for this question if any of the correct options are chosen.

Question Number : 91 Question Id : 80089419936 Question Type : MCQ Option Shuffling : Yes

Display Question Number : Yes Is Question Mandatory : No Option Orientation : Vertical

Correct Marks : 1 Wrong Marks : 0

Which metals from the following can provide cathodic protection to Iron?

Options :

1. ✘ Zn and Cu

2. ✘ Al and Cu

3. ✘ Al and Ni

4. ✓ Al and Zn

Question Number : 92 Question Id : 80089419937 Question Type : MCQ Option Shuffling : Yes

Display Question Number : Yes Is Question Mandatory : No Option Orientation : Vertical

Correct Marks : 1 Wrong Marks : 0

The hardness of water is caused by

Options :

1. ✗ Undissolved salts of Ca^{+2} and Mg^{+2}

2. ✗ Undissolved salts of Cu^{+2} and Mg^{+2}

3. ✓ Dissolved salts of Ca^{+2} and Mg^{+2}

4. ✗ Undissolved CaCO_3

Question Number : 93 Question Id : 80089419938 Question Type : MCQ Option Shuffling : Yes

Display Question Number : Yes Is Question Mandatory : No Option Orientation : Vertical

Correct Marks : 1 Wrong Marks : 0

A water sample contains 204 mg of CaSO_4 per Litre. Its hardness in terms of CaCO_3 equivalent is

Options :

1. ✓ 150 ppm

2. ✗ 136 ppm

3. ✗ 204 ppm

100 ppm

4. ✘

Question Number : 94 Question Id : 80089419939 Question Type : MCQ Option Shuffling : Yes

Display Question Number : Yes Is Question Mandatory : No Option Orientation : Vertical

Correct Marks : 1 Wrong Marks : 0

Hard water can block radiators due to the formation of?

Options :

1. ✔ insoluble calcium and magnesium salts

2. ✘ insoluble sodium salts

3. ✘ insoluble phosphate salts

4. ✘ insoluble potassium salts

Question Number : 95 Question Id : 80089419940 Question Type : MCQ Option Shuffling : Yes

Display Question Number : Yes Is Question Mandatory : No Option Orientation : Vertical

Correct Marks : 1 Wrong Marks : 0

Choose the incorrect statement from the following options.

Options :

The molecular weight of the polymer steadily rises throughout the reaction,

1. ✘ in condensation polymerisation

2. ✘ In addition polymerisation, growth of chain is at one active centre.

3. ✘ No by product will be formed in the addition polymerisation

The molecular weight of the polymer steadily increases throughout the reaction,

4. ✓ in addition polymerisation

Question Number : 96 Question Id : 80089419941 Question Type : MCQ Option Shuffling : Yes

Display Question Number : Yes Is Question Mandatory : No Option Orientation : Vertical

Correct Marks : 1 Wrong Marks : 0

Which of the following is a thermoplastic?

Options :

1. ✓ Teflon
2. ✗ Natural rubber
3. ✗ Neoprene
4. ✗ Buna-S

Question Number : 97 Question Id : 80089419942 Question Type : MCQ Option Shuffling : Yes

Display Question Number : Yes Is Question Mandatory : No Option Orientation : Vertical

Correct Marks : 1 Wrong Marks : 0

Which of the following a characteristic feature is of a good fuel?

Options :

1. ✗ High moisture content
2. ✗ Should undergo spontaneous combustion
3. ✗ Low calorific value

4. ✓ High calorific value

Question Number : 98 Question Id : 80089419943 Question Type : MCQ Option Shuffling : Yes

Display Question Number : Yes Is Question Mandatory : No Option Orientation : Vertical

Correct Marks : 1 Wrong Marks : 0

Producer gas is primarily a mixture of

Options :

1. ✓ CO + N₂

2. ✗ CO + H₂

3. ✗ CO + CH₄

4. ✗ N₂ + H₂

Question Number : 99 Question Id : 80089419944 Question Type : MCQ Option Shuffling : Yes

Display Question Number : Yes Is Question Mandatory : No Option Orientation : Vertical

Correct Marks : 1 Wrong Marks : 0

The measurement of dissolved oxygen used by microorganisms during the biochemical oxidation of organic matter in 5 days at 20°C is said to be

Options :

1. ✓ Biological Oxygen Demand

2. ✗ Chemical Oxygen Demand

3. ✗ Biological Dissolved Oxygen

4. ✘ Threshold Oxygen Demand

Question Number : 100 Question Id : 80089419945 Question Type : MCQ Option Shuffling : Yes
Display Question Number : Yes Is Question Mandatory : No Option Orientation : Vertical
Correct Marks : 1 Wrong Marks : 0

Which of the following is a green house gas?

Options :

1. ✘ H₂

2. ✘ N₂

3. ✘ CO

4. ✔ CO₂

Electronics and Instrumentation Engineering

Section Id :	800894391
Section Number :	4
Section type :	Online
Mandatory or Optional :	Mandatory
Number of Questions :	100
Number of Questions to be attempted :	100
Section Marks :	100
Enable Mark as Answered Mark for Review and Clear Response :	Yes
Sub-Section Number :	1

Sub-Section Id :

800894445

Question Shuffling Allowed :

Yes

Question Number : 101 Question Id : 80089419946 Question Type : MCQ Option Shuffling : Yes

Display Question Number : Yes Is Question Mandatory : No Option Orientation : Vertical

Correct Marks : 1 Wrong Marks : 0

Two coils of self inductance 8 H and 10 H are connected in parallel such a way that their mutual inductance of 4 H

assists the self inductances. The effective inductance of the combination is

Options :

1. ✘ 2.4 H

2. ✔ 6.4 H

3. ✘ 10 H

4. ✘ 26 H

Question Number : 102 Question Id : 80089419947 Question Type : MCQ Option Shuffling : Yes

Display Question Number : Yes Is Question Mandatory : No Option Orientation : Vertical

Correct Marks : 1 Wrong Marks : 0

A two winding transformer has iron losses and full load copper losses equal to W watts each. It is tested along

with another similar transformer for back to back test. The total power input would be

Options :

1. ✔ 4 W

2. ✘ 2 W

3. ✘ 1 W

4. ✘ 0.5 W

Question Number : 103 Question Id : 80089419948 Question Type : MCQ Option Shuffling : Yes

Display Question Number : Yes Is Question Mandatory : No Option Orientation : Vertical

Correct Marks : 1 Wrong Marks : 0

How many kilocalories of heat will approximately be developed in a 420 W electric bulb in 10 minutes?

Options :

1. ✘ 25.2

2. ✘ 10.5

3. ✘ 30

4. ✔ 60

Question Number : 104 Question Id : 80089419949 Question Type : MCQ Option Shuffling : Yes

Display Question Number : Yes Is Question Mandatory : No Option Orientation : Vertical

Correct Marks : 1 Wrong Marks : 0

In a linear network, the ratio of voltage excitation to current response is unaltered when the position of excitation and response are interchanged. This assertion stems from the

Options :

1. ✘ Principle of duality

2. ✔

Reciprocity theorem

3. ✘ Principle of Superposition

4. ✘ Equivalence theorem

Question Number : 105 Question Id : 80089419950 Question Type : MCQ Option Shuffling : Yes
Display Question Number : Yes Is Question Mandatory : No Option Orientation : Vertical

Correct Marks : 1 Wrong Marks : 0

The following $V - I$ characteristic represents

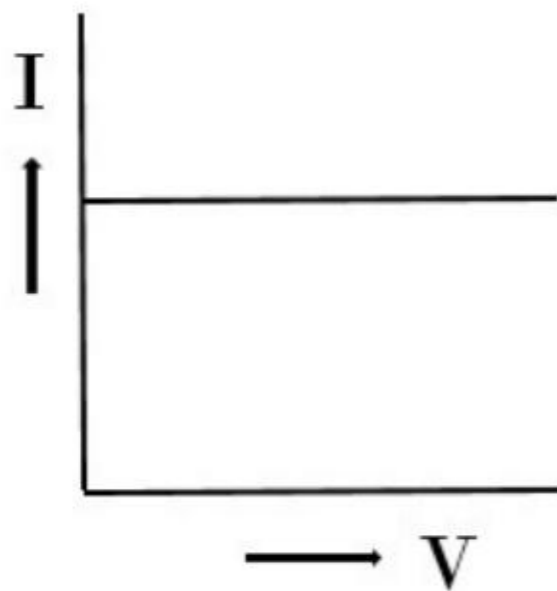

Options :

1. ✔ Ideal Current Source

2. ✘ Ideal Voltage Source

3. ✘ Practical Current Source

4. ✘ Practical Voltage Source

Question Number : 106 Question Id : 80089419951 Question Type : MCQ Option Shuffling : Yes
Display Question Number : Yes Is Question Mandatory : No Option Orientation : Vertical
Correct Marks : 1 Wrong Marks : 0

Which of the following is not a part of transformer?

Options :

1. ✘ Core
2. ✘ Coils
3. ✔ Rotor
4. ✘ Transformer oil

Question Number : 107 Question Id : 80089419952 Question Type : MCQ Option Shuffling : Yes
Display Question Number : Yes Is Question Mandatory : No Option Orientation : Vertical
Correct Marks : 1 Wrong Marks : 0

The unit of absolute permittivity is

Options :

1. ✘ Volt/ metre
2. ✘ Coulomb/ Farad
3. ✔ Farad/ metre
4. ✘ Coulomb/meter²

Question Number : 108 Question Id : 80089419953 Question Type : MCQ Option Shuffling : Yes
Display Question Number : Yes Is Question Mandatory : No Option Orientation : Vertical
Correct Marks : 1 Wrong Marks : 0

The direction of rotation of a d.c motor can be reversed

Options :

1. ✘ By reversing the connections of both armature and the field windings with the supply
2. ✔ By reversing the connections of either the armature or the field.
3. ✘ By reducing the field flux
4. ✘ By introducing an extra resistance in the armature circuit

Question Number : 109 Question Id : 80089419954 Question Type : MCQ Option Shuffling : Yes
Display Question Number : Yes Is Question Mandatory : No Option Orientation : Vertical
Correct Marks : 1 Wrong Marks : 0

Which of the following are same for primary and secondary of a 1- phase transformer?

Options :

1. ✘ Resistances and leakage reactances only
2. ✘ Currents and induced voltages only
3. ✔ Voltage per turn and Ampere-turns only
4. ✘ Copper loss only

Question Number : 110 Question Id : 80089419955 Question Type : MCQ Option Shuffling : Yes

Display Question Number : Yes Is Question Mandatory : No Option Orientation : Vertical

Correct Marks : 1 Wrong Marks : 0

The slip of 400 V, three phase, 50 Hz, 4-pole induction motor when rotating at 1440 r.p.m is

Options :

1. ✘ 2%

2. ✘ 3%

3. ✔ 4%

4. ✘ 5%

Question Number : 111 Question Id : 80089419956 Question Type : MCQ Option Shuffling : Yes

Display Question Number : Yes Is Question Mandatory : No Option Orientation : Vertical

Correct Marks : 1 Wrong Marks : 0

Torque developed by a three-phase, 400 V, Induction motor is 100 N-m. If the applied voltage is reduced to 200-V, the developed torque will be

Options :

1. ✘ 50 N-m

2. ✔ 25 N-m

3. ✘ 200 N-m

4. ✘ 62.5 N-m

Question Number : 112 Question Id : 80089419957 Question Type : MCQ Option Shuffling : Yes

Display Question Number : Yes Is Question Mandatory : No Option Orientation : Vertical

Correct Marks : 1 Wrong Marks : 0

A voltage source is delivering a maximum power of 25 W to the load. The power generated by the source is

Options :

1. ✘ 25 W

2. ✘ 75 W

3. ✘ 100 W

4. ✔ 50 W

Question Number : 113 Question Id : 80089419958 Question Type : MCQ Option Shuffling : Yes

Display Question Number : Yes Is Question Mandatory : No Option Orientation : Vertical

Correct Marks : 1 Wrong Marks : 0

When the rotor circuit resistance of a poly phase induction motor is increased

Options :

1. ✔ The starting torque increases

2. ✘ The maximum value of torque increases

3. ✘ The slip at which maximum torque occurs remains unchanged

4. ✘ Maximum torque is developed at starting

Question Number : 114 Question Id : 80089419959 Question Type : MCQ Option Shuffling : Yes

Display Question Number : Yes Is Question Mandatory : No Option Orientation : Vertical

Correct Marks : 1 Wrong Marks : 0

The rotor reactance of a 3-phase Induction motor under running conditions, is proportional to

Options :

1. ✓ Slip
2. ✗ $1/\text{slip}$
3. ✗ Supply voltage
4. ✗ Induced e.m.f

Question Number : 115 Question Id : 80089419960 Question Type : MCQ Option Shuffling : Yes

Display Question Number : Yes Is Question Mandatory : No Option Orientation : Vertical

Correct Marks : 1 Wrong Marks : 0

Primary cells are

Options :

1. ✗ Rechargeable
2. ✓ Can't Recharge
3. ✗ Discharges fast
4. ✗ Wet cells

Question Number : 116 Question Id : 80089419961 Question Type : MCQ Option Shuffling : Yes

Display Question Number : Yes Is Question Mandatory : No Option Orientation : Vertical

Correct Marks : 1 Wrong Marks : 0

Current flowing in an inductor 'L' is given by the formula

Options :

1. ✓ $i = \frac{1}{L} \int_{-\infty}^t V dt$

2. ✗ $i = L \frac{dv}{dt}$

3. ✗ $i = L \int_{-\infty}^t V dt$

4. ✗ $i = \frac{1}{L} \frac{dv}{dt}$

Question Number : 117 Question Id : 80089419962 Question Type : MCQ Option Shuffling : Yes

Display Question Number : Yes Is Question Mandatory : No Option Orientation : Vertical

Correct Marks : 1 Wrong Marks : 0

Light emitting diode (LED) operates in

Options :

1. ✓ Forward bias

2. ✗ Reverse bias

3. ✗ Both forward & reverse

4. ✘ Un bias

Question Number : 118 Question Id : 80089419963 Question Type : MCQ Option Shuffling : Yes

Display Question Number : Yes Is Question Mandatory : No Option Orientation : Vertical

Correct Marks : 1 Wrong Marks : 0

Given two coupled inductors L_1 and L_2 , their mutual inductance M satisfies

Options :

1. ✘ $M = \sqrt{L_1^2 + L_2^2}$

2. ✘ $M > \frac{L_1 + L_2}{2}$

3. ✘ $M > \sqrt{L_1 L_2}$

4. ✔ $M \leq \sqrt{L_1 L_2}$

Question Number : 119 Question Id : 80089419964 Question Type : MCQ Option Shuffling : Yes

Display Question Number : Yes Is Question Mandatory : No Option Orientation : Vertical

Correct Marks : 1 Wrong Marks : 0

Which of the following diode used in voltage regulator?

Options :

1. ✘ LED

2. ✘ Photo diode

3. ✔ Zener diode

4. ✘ Forward biased Zener diode

Question Number : 120 Question Id : 80089419965 Question Type : MCQ Option Shuffling : Yes
Display Question Number : Yes Is Question Mandatory : No Option Orientation : Vertical
Correct Marks : 1 Wrong Marks : 0

For the circuit shown below, calculate the voltage across each diode V_1 and V_2 . If the diodes are identical and made up of silicon and also breakdown voltage of each diode is greater than 5V

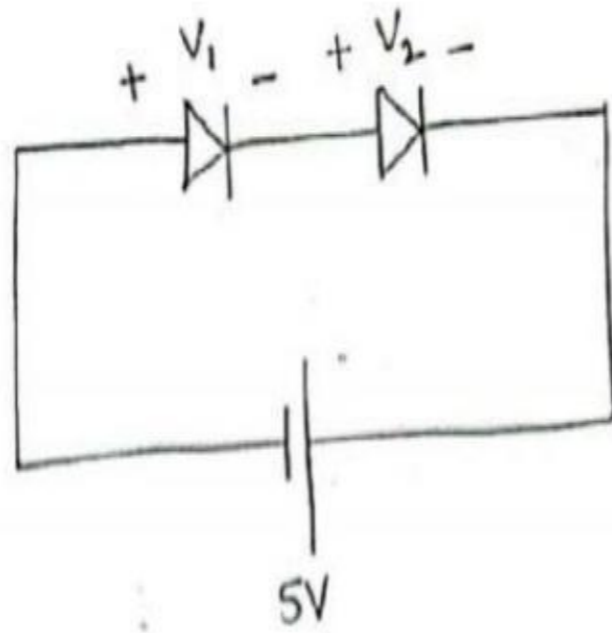

Options :

1. ✘ 2.5V

2. ✘ 5V

3. ✔ -2.5V

4. ✘ 0V

Question Number : 121 Question Id : 80089419966 Question Type : MCQ Option Shuffling : Yes
Display Question Number : Yes Is Question Mandatory : No Option Orientation : Vertical

Correct Marks : 1 Wrong Marks : 0

In-an n-type silicon, which of the following statement is true

Options :

1. ✘ $n_e \gg n_h$ and trivalent atoms are dopants
2. ✔ $n_e \gg n_h$ and pentavalent atoms are dopants
3. ✘ $n_e \ll n_h$ and pentavalent atoms are dopants
4. ✘ $n_e \ll n_h$ and trivalent atoms are dopants

Question Number : 122 Question Id : 80089419967 Question Type : MCQ Option Shuffling : Yes

Display Question Number : Yes Is Question Mandatory : No Option Orientation : Vertical

Correct Marks : 1 Wrong Marks : 0

Consider the following statements, A tunnel diode is :

- a) made of Ge and GaAs
- b) an abrupt junction with both sides heavily doped
- c) an abrupt junction with one side heavily doped
- d) a majority carrier device

Which of the following statements are correct

Options :

1. ✔ a and b
2. ✘ c and d

3. ✘ a, c and d

4. ✘ a, b and d

Question Number : 123 Question Id : 80089419968 Question Type : MCQ Option Shuffling : Yes

Display Question Number : Yes Is Question Mandatory : No Option Orientation : Vertical

Correct Marks : 1 Wrong Marks : 0

Voltage gain for a transistor amplifier is _____

Options :

1. ✘ Constant for all frequencies

2. ✔ Constant for mid frequencies

3. ✘ High at high frequencies

4. ✘ High at low frequencies

Question Number : 124 Question Id : 80089419969 Question Type : MCQ Option Shuffling : Yes

Display Question Number : Yes Is Question Mandatory : No Option Orientation : Vertical

Correct Marks : 1 Wrong Marks : 0

The transfer characteristic in the circuit shown below if V_{in} ranges from -10V to 10V is:

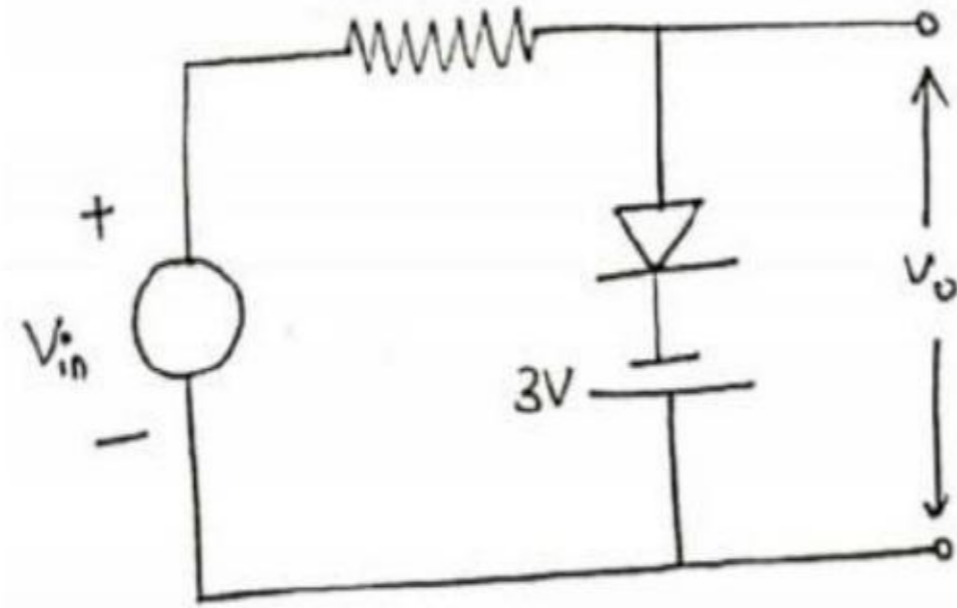

Options :

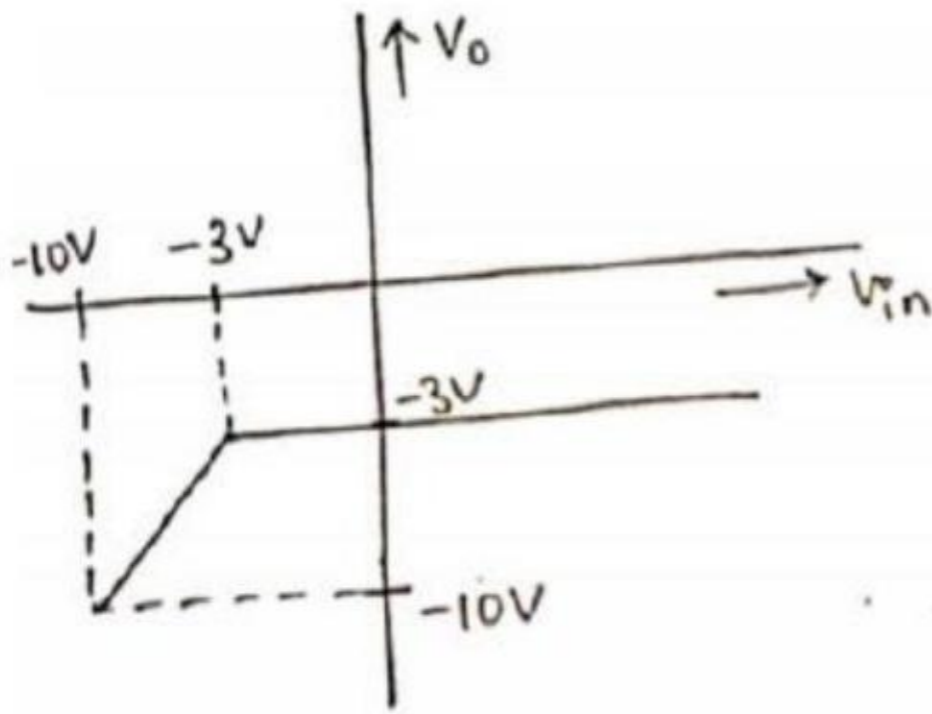

1. ✓

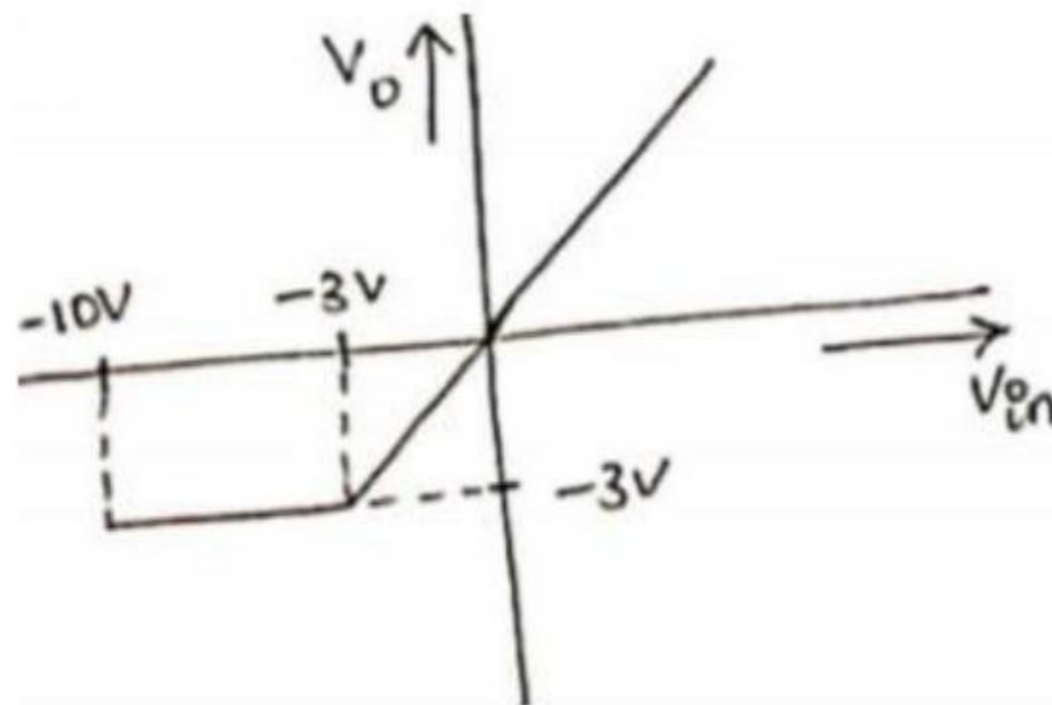

2. ✗

3. ✗

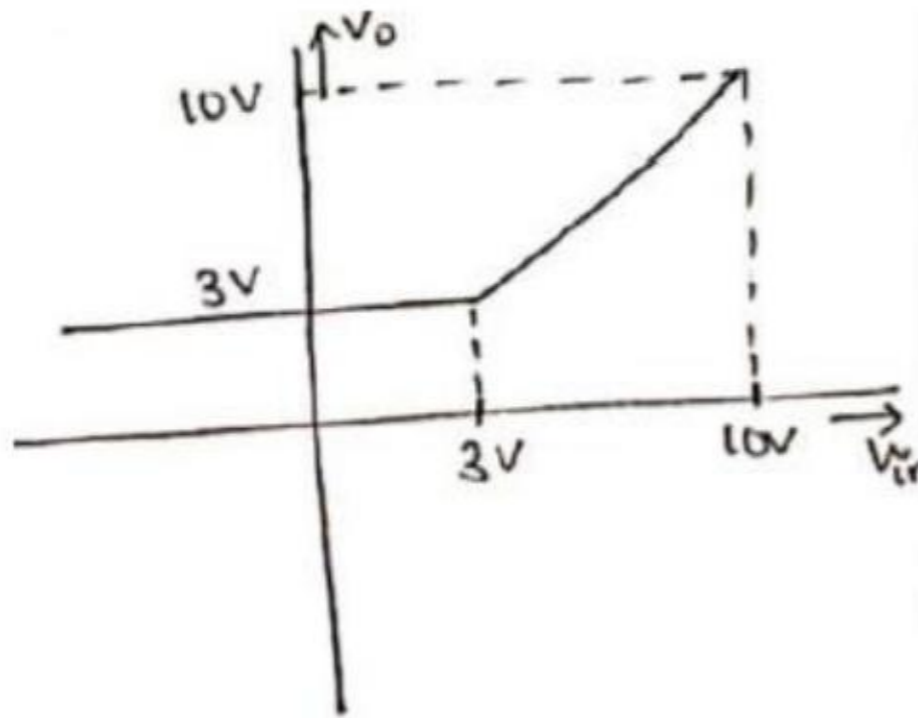
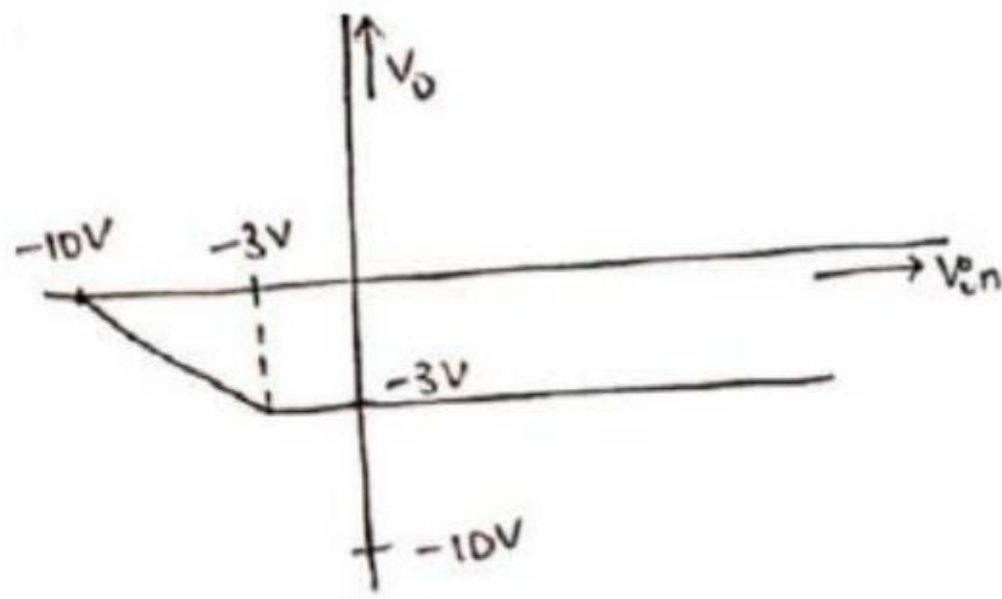

4. ✘

Question Number : 125 Question Id : 80089419970 Question Type : MCQ Option Shuffling : Yes

Display Question Number : Yes Is Question Mandatory : No Option Orientation : Vertical

Correct Marks : 1 Wrong Marks : 0

For a CE-transistor amplifier, the signal voltage across the R_c of $2\text{ k}\Omega$ is 2 V . Current amplification factor of transistor is 100. If base resistance is $1\text{ k}\Omega$, find the input signal voltage?

Options :

1. ✔ 0.01 v

2. ✘ 0.001 v

3. ✘ 0.1 v

4. ✘ 1.0 v

Question Number : 126 Question Id : 80089419971 Question Type : MCQ Option Shuffling : Yes

Display Question Number : Yes Is Question Mandatory : No Option Orientation : Vertical

Correct Marks : 1 Wrong Marks : 0

Darlington circuit is consists of two transistors

Options :

1. ✘ in common base configuration connected in series
2. ✔ in common collector configuration connected in series
3. ✘ in common emitter configuration connected in parallel
4. ✘ in common base configuration connected in parallel

Question Number : 127 Question Id : 80089419972 Question Type : MCQ Option Shuffling : Yes

Display Question Number : Yes Is Question Mandatory : No Option Orientation : Vertical

Correct Marks : 1 Wrong Marks : 0

Medium input and output impedance amplifier is

Options :

1. ✔ Common-Emitter (CE) type
2. ✘ C-B type
3. ✘ C-C type
4. ✘

Cascaded

Question Number : 128 Question Id : 80089419973 Question Type : MCQ Option Shuffling : Yes

Display Question Number : Yes Is Question Mandatory : No Option Orientation : Vertical

Correct Marks : 1 Wrong Marks : 0

Class B, push pull amplifier has conversion efficiency of _____ theoretically

Options :

1. ✓ 78.5%

2. ✗ 50%

3. ✗ 25%

4. ✗ 100%

Question Number : 129 Question Id : 80089419974 Question Type : MCQ Option Shuffling : Yes

Display Question Number : Yes Is Question Mandatory : No Option Orientation : Vertical

Correct Marks : 1 Wrong Marks : 0

Potentiometers (PoT) is a

Options :

1. ✗ Fixed Resister

2. ✓ Variable resister

3. ✗ Temperature dependent Resistor

4. ✗

Insulator

Question Number : 130 Question Id : 80089419975 Question Type : MCQ Option Shuffling : Yes

Display Question Number : Yes Is Question Mandatory : No Option Orientation : Vertical

Correct Marks : 1 Wrong Marks : 0

The voltage gain $\frac{V_o}{V_{in}}$ for the following circuit is _____, Assume $V_{BE}=0.7V$, $\beta=100$

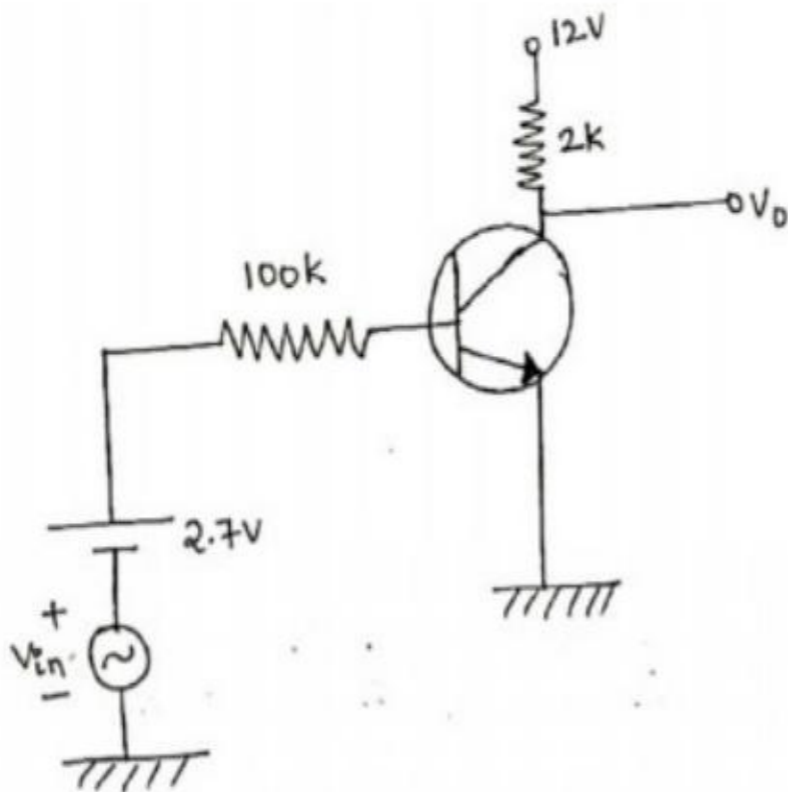

Options :

1. ✘ -1.5

2. ✔ -1.97

3. ✘ -2.5

4. ✘ 1.5

Question Number : 131 Question Id : 80089419976 Question Type : MCQ Option Shuffling : Yes

Display Question Number : Yes Is Question Mandatory : No Option Orientation : Vertical

Correct Marks : 1 Wrong Marks : 0

An ideal operational amplifier (op-amp) should have bandwidth of

Options :

1. ✘ Zero
2. ✘ Maximum
3. ✔ Infinite
4. ✘ Minimum

Question Number : 132 Question Id : 80089419977 Question Type : MCQ Option Shuffling : Yes

Display Question Number : Yes Is Question Mandatory : No Option Orientation : Vertical

Correct Marks : 1 Wrong Marks : 0

For a transistor to be in _____ region for acting as amplifier

Options :

1. ✘ Saturation region
2. ✔ Active region
3. ✘ Cut off region
4. ✘ Reverse cut off region

Question Number : 133 Question Id : 80089419978 Question Type : MCQ Option Shuffling : Yes

Display Question Number : Yes Is Question Mandatory : No Option Orientation : Vertical

Correct Marks : 1 Wrong Marks : 0

Cascode amplifier consist of

Options :

1. ✓ CE stage followed by CB stage
2. ✗ CB stage followed by CE stage
3. ✗ CE stage followed by CC stage
4. ✗ CB stage followed by CC stage

Question Number : 134 Question Id : 80089419979 Question Type : MCQ Option Shuffling : Yes

Display Question Number : Yes Is Question Mandatory : No Option Orientation : Vertical

Correct Marks : 1 Wrong Marks : 0

With usual notations, the condition for sustained oscillations in Colpitts Oscillator is

Options :

1. ✓ $|A_v| \geq \frac{C_1}{C_2}$
2. ✗ $|A_v| \leq \frac{C_1}{C_2}$
3. ✗ $|A_v| \geq \frac{R_1 C_1}{R_2 C_2}$
4. ✗ $|A_v| \leq \frac{R_1 C_1}{R_2 C_2}$

Question Number : 135 Question Id : 80089419980 Question Type : MCQ Option Shuffling : Yes

Display Question Number : Yes Is Question Mandatory : No Option Orientation : Vertical

Correct Marks : 1 Wrong Marks : 0

Which is the basic element of all the a.c signal sources, generates sinusoidal signal of a known frequency?

Options :

1. ✘ Amplifier
2. ✔ Oscillator
3. ✘ Transformer
4. ✘ Filter

Question Number : 136 Question Id : 80089419981 Question Type : MCQ Option Shuffling : Yes

Display Question Number : Yes Is Question Mandatory : No Option Orientation : Vertical

Correct Marks : 1 Wrong Marks : 0

The number 43 in 2's complement representation is

Options :

1. ✘ 01010101
2. ✘ 11010101
3. ✔ 00101011
4. ✘ 10101011

Question Number : 137 Question Id : 80089419982 Question Type : MCQ Option Shuffling : Yes

Display Question Number : Yes Is Question Mandatory : No Option Orientation : Vertical

Correct Marks : 1 Wrong Marks : 0

Electronic Calculator is a

Options :

1. ✓ Digital system
2. ✘ Analog system
3. ✘ Control system
4. ✘ Multiplexer

Question Number : 138 Question Id : 80089419983 Question Type : MCQ Option Shuffling : Yes

Display Question Number : Yes Is Question Mandatory : No Option Orientation : Vertical

Correct Marks : 1 Wrong Marks : 0

Universal gates are

Options :

1. ✘ AND, NAND
2. ✘ OR, NOR
3. ✓ NAND, NOR
4. ✘ AND, OR

Question Number : 139 Question Id : 80089419984 Question Type : MCQ Option Shuffling : Yes

Display Question Number : Yes Is Question Mandatory : No Option Orientation : Vertical

Correct Marks : 1 Wrong Marks : 0

RAM is a memory type of

Options :

1. ✓ Volatile
2. ✗ Non Volatile
3. ✗ Read only type
4. ✗ Write only type

Question Number : 140 Question Id : 80089419985 Question Type : MCQ Option Shuffling : Yes

Display Question Number : Yes Is Question Mandatory : No Option Orientation : Vertical

Correct Marks : 1 Wrong Marks : 0

In half Adder circuit, sum & carry bits are implemented with gates respectively

Options :

1. ✓ EX-OR, AND
2. ✗ EX-OR, OR
3. ✗ AND, EX-OR
4. ✗ EX-OR, EX-NOR

Question Number : 141 Question Id : 80089419986 Question Type : MCQ Option Shuffling : Yes

Display Question Number : Yes Is Question Mandatory : No Option Orientation : Vertical

Correct Marks : 1 Wrong Marks : 0

Decade counters is also known as

Options :

1. ✘ Mod – 8
2. ✔ Mod – 10
3. ✘ Mod – 16
4. ✘ Mod - N

Question Number : 142 Question Id : 80089419987 Question Type : MCQ Option Shuffling : Yes

Display Question Number : Yes Is Question Mandatory : No Option Orientation : Vertical

Correct Marks : 1 Wrong Marks : 0

4 x1 Multiplexer has

Options :

1. ✔ 4 data inputs, 2 selection lines, 1 output
2. ✘ 2 data inputs, 4 selection lines, 1 output
3. ✘ 1 data inputs, 2 selection lines, 4 output
4. ✘ 4 data inputs, 1 selection lines, 2 output

Question Number : 143 Question Id : 80089419988 Question Type : MCQ Option Shuffling : Yes

Display Question Number : Yes Is Question Mandatory : No Option Orientation : Vertical

Correct Marks : 1 Wrong Marks : 0

The output of a gate is LOW when at least one of its inputs is HIGH. This is true for

Options :

1. ✘ AND
2. ✘ NAND
3. ✘ OR
4. ✔ NOR

Question Number : 144 Question Id : 80089419989 Question Type : MCQ Option Shuffling : Yes

Display Question Number : Yes Is Question Mandatory : No Option Orientation : Vertical

Correct Marks : 1 Wrong Marks : 0

If a counter having 10 Flipflops is initially at 0. What count will it hold after 2060 pulses?

Options :

1. ✔ 000 000 1100
2. ✘ 000 001 1100
3. ✘ 000 001 1000
4. ✘ 000 000 1110

Question Number : 145 Question Id : 80089419990 Question Type : MCQ Option Shuffling : Yes

Display Question Number : Yes Is Question Mandatory : No Option Orientation : Vertical

Correct Marks : 1 Wrong Marks : 0

A pulse train with a frequency of 1MHz is counted using modulo-1024 ripple counter built with J-K flipflops. For proper operation of counter, the maximum permissible propagation delay per flipflop stage is -----

Options :

1. ✘ 10 nSec
2. ✘ 1000 nSec
3. ✔ 100 nSec
4. ✘ 1 nSec

Question Number : 146 Question Id : 80089419991 Question Type : MCQ Option Shuffling : Yes Display Question Number : Yes Is Question Mandatory : No Option Orientation : Vertical Correct Marks : 1 Wrong Marks : 0

A circuit in which data gets shifted towards left or right when clock pulses are applied is called

Options :

1. ✘ Flip flop
2. ✔ Shift Register
3. ✘ Counter
4. ✘ Latch

Question Number : 147 Question Id : 80089419992 Question Type : MCQ Option Shuffling : Yes

Display Question Number : Yes Is Question Mandatory : No Option Orientation : Vertical

Correct Marks : 1 Wrong Marks : 0

The dual of a Boolean function is obtained by

Options :

1. ✘ Interchanging all 0s and 1s only
2. ✘ Changing all 0s to 1s only
3. ✘ Changing all 1s to 0s only
4. ✔ Interchanging (i) all 0s and 1s and (ii) '+' and '-' signs

Question Number : 148 Question Id : 80089419993 Question Type : MCQ Option Shuffling : Yes

Display Question Number : Yes Is Question Mandatory : No Option Orientation : Vertical

Correct Marks : 1 Wrong Marks : 0

Value of MSB and full scale output for an 8-bit DAC for $V_R=10V$ is

Options :

1. ✘ 5V, 10V
2. ✔ 5V, 9.961V
3. ✘ 9.961V, 5V
4. ✘ 10V, 5V

Question Number : 149 Question Id : 80089419994 Question Type : MCQ Option Shuffling : Yes

Display Question Number : Yes Is Question Mandatory : No Option Orientation : Vertical

Correct Marks : 1 Wrong Marks : 0

Karnaugh map is used to

Options :

1. ✘ Minimise the number of flip-flops in a digital circuit
2. ✘ Maximize the number of gates
3. ✘ Maximize the fan-in requirements
4. ✔ Minimize the number of gates and fan-in requirements of the gates in a digital circuit

Question Number : 150 Question Id : 80089419995 Question Type : MCQ Option Shuffling : Yes

Display Question Number : Yes Is Question Mandatory : No Option Orientation : Vertical

Correct Marks : 1 Wrong Marks : 0

Maximum Conversion time in successive approximation ADC is

Options :

1. ✔ N Clock Cycles
2. ✘ 2^N Clock Cycles
3. ✘ $2^{N+1}-1$ Clock Cycles
4. ✘ $2^{N-1}-1$ Clock Cycles

Question Number : 151 Question Id : 80089419996 Question Type : MCQ Option Shuffling : Yes

Display Question Number : Yes Is Question Mandatory : No Option Orientation : Vertical

Correct Marks : 1 Wrong Marks : 0

A transducers is a device which

Options :

1. ✘ Transfers a signal from one circuit to the other
2. ✔ Converts a physical quantity to be measured into an equivalent electrical signal
3. ✘ Amplifies a signal for the purpose of measurement
4. ✘ Converts an ac signal into a dc signal.

Question Number : 152 Question Id : 80089419997 Question Type : MCQ Option Shuffling : Yes

Display Question Number : Yes Is Question Mandatory : No Option Orientation : Vertical

Correct Marks : 1 Wrong Marks : 0

An analog transducer with a 0-10V input is able to distinguish a change of 10mV in its input signal if its resolution

is

Options :

1. ✘ 1 part in 100
2. ✔ 1 part in 1000
3. ✘ 1 part in 10
4. ✘ 1 part in 10000

Question Number : 153 Question Id : 80089419998 Question Type : MCQ Option Shuffling : Yes

Display Question Number : Yes Is Question Mandatory : No Option Orientation : Vertical

Correct Marks : 1 Wrong Marks : 0

Which of the following is an active transducer?

Options :

1. ✘ Thermistor
2. ✘ LVDT
3. ✘ Photo transistor
4. ✔ Thermocouple

Question Number : 154 Question Id : 80089419999 Question Type : MCQ Option Shuffling : Yes

Display Question Number : Yes Is Question Mandatory : No Option Orientation : Vertical

Correct Marks : 1 Wrong Marks : 0

The emf developed by a thermocouple depends on

Options :

1. ✘ The length of wires and temperature difference between the hot and cold junctions
2. ✘ Materials used, diameter of wires used and temperature difference between the hot and cold junctions
3. ✔ Materials used, temperature of hot junction and temperature of cold junction
4. ✘ Materials used, shape and size of materials, resistance of the wires and temperature difference between the hot and cold junctions

Question Number : 155 Question Id : 80089420000 Question Type : MCQ Option Shuffling : Yes

Display Question Number : Yes Is Question Mandatory : No Option Orientation : Vertical

Correct Marks : 1 Wrong Marks : 0

A thermistor is a

Options :

1. ✘ Temperature-dependent resistor with +ve temperature coefficient of resistance
2. ✔ Temperature-dependent resistor with -ve temperature coefficient of resistance
3. ✘ Temperature-independent resistor with +ve temperature coefficient of resistance
4. ✘ Temperature-independent resistor with -ve temperature coefficient of resistance

Question Number : 156 Question Id : 80089420001 Question Type : MCQ Option Shuffling : Yes

Display Question Number : Yes Is Question Mandatory : No Option Orientation : Vertical

Correct Marks : 1 Wrong Marks : 0

A piezoelectric type accelerometer has a sensitivity of 100mV/g. The transducer is subjected to a constant

acceleration of 5g. The steady state output of the transducer will be

Options :

1. ✔ 0V
2. ✘ 100mV
3. ✘ 0.5V

4. ✘ 5.0V

Question Number : 157 Question Id : 8008942002 Question Type : MCQ Option Shuffling : Yes

Display Question Number : Yes Is Question Mandatory : No Option Orientation : Vertical

Correct Marks : 1 Wrong Marks : 0

Which one of the following is Inductive type transducer?

Options :

1. ✔ LVDT-type transducer

2. ✘ Thermistor transducers

3. ✘ Thermocouple-type transducer

4. ✘ Strain gauge

Question Number : 158 Question Id : 8008942003 Question Type : MCQ Option Shuffling : Yes

Display Question Number : Yes Is Question Mandatory : No Option Orientation : Vertical

Correct Marks : 1 Wrong Marks : 0

The differential pressure transmitter of a flow meter using a venturi tube reads 2.5×10^5 Pa for a flow rate of $0.5 \text{ m}^3/\text{s}$.

The approximate flow rate in m^3/s for a differential pressure of 0.9×10^5 Pa is

Options :

1. ✔ 0.30

2. ✘ 0.18

3. ✘ 0.83

4. ✘ 0.60

Question Number : 159 Question Id : 80089420004 Question Type : MCQ Option Shuffling : Yes Display Question Number : Yes Is Question Mandatory : No Option Orientation : Vertical

Correct Marks : 1 Wrong Marks : 0

Which of the following is variable area flow meter?

Options :

1. ✘ Orifice
2. ✘ Venturi
3. ✘ Ultrasonic
4. ✔ Rotameter

Question Number : 160 Question Id : 80089420005 Question Type : MCQ Option Shuffling : Yes Display Question Number : Yes Is Question Mandatory : No Option Orientation : Vertical

Correct Marks : 1 Wrong Marks : 0

Scale factor of transducer is

Options :

1. ✔ Directly proportional to sensitivity
2. ✘ Inversely proportional to sensitivity
3. ✘ Directly proportional to square of sensitivity

4. ✘ Inversely proportional to square of sensitivity

Question Number : 161 Question Id : 80089420006 Question Type : MCQ Option Shuffling : Yes

Display Question Number : Yes Is Question Mandatory : No Option Orientation : Vertical

Correct Marks : 1 Wrong Marks : 0

Strain gauge is not used for measurement of

Options :

1. ✘ Force

2. ✘ Torque

3. ✘ Pressure

4. ✔ Temperature

Question Number : 162 Question Id : 80089420007 Question Type : MCQ Option Shuffling : Yes

Display Question Number : Yes Is Question Mandatory : No Option Orientation : Vertical

Correct Marks : 1 Wrong Marks : 0

Pneumatic transducer is used to measure

Options :

1. ✔ Pressure

2. ✘ Alkalinity

3. ✘ Flow of liquid

4. ✘ Viscosity

Question Number : 163 Question Id : 80089420008 Question Type : MCQ Option Shuffling : Yes Display Question Number : Yes Is Question Mandatory : No Option Orientation : Vertical Correct Marks : 1 Wrong Marks : 0

Which of the following are the Hydel power plant units?

- I. Reservoir & Dam
- II. Boiler
- III. Turbine
- IV. Generator

Options :

1. ✘ I,II,III,IV

2. ✔ I,III,IV

3. ✘ II,III,IV

4. ✘ I,IV

Question Number : 164 Question Id : 80089420009 Question Type : MCQ Option Shuffling : Yes Display Question Number : Yes Is Question Mandatory : No Option Orientation : Vertical Correct Marks : 1 Wrong Marks : 0

Which of the following nuclear reactor doesn't require a heat exchanger to supply steam to power turbine?

Options :

1. ✘ Molten sodium cooled

2. ✘ Helium cooled

3. ✔ Boiling water

4. ✘ Pressurized water

Question Number : 165 Question Id : 80089420010 Question Type : MCQ Option Shuffling : Yes

Display Question Number : Yes Is Question Mandatory : No Option Orientation : Vertical

Correct Marks : 1 Wrong Marks : 0

Wet-end and dry-end operators are used in manufacturing of

Options :

1. ✘ Iron & Steel

2. ✔ Paper

3. ✘ Power

4. ✘ Cement

Question Number : 166 Question Id : 80089420011 Question Type : MCQ Option Shuffling : Yes

Display Question Number : Yes Is Question Mandatory : No Option Orientation : Vertical

Correct Marks : 1 Wrong Marks : 0

Which one of the following is open loop control system?

Options :

1. ✔ Traffic light control

2. ✘ A thermostatic control
3. ✘ The respiratory system of human being
4. ✘ A system for controlling the movement of the slide of a copying milling machine

Question Number : 167 Question Id : 80089420012 Question Type : MCQ Option Shuffling : Yes Display Question Number : Yes Is Question Mandatory : No Option Orientation : Vertical Correct Marks : 1 Wrong Marks : 0

Which one of the following is Cheapest and simple control system?

Options :

1. ✔ Open loop
2. ✘ Close loop
3. ✘ Non linear
4. ✘ Cacade

Question Number : 168 Question Id : 80089420013 Question Type : MCQ Option Shuffling : Yes Display Question Number : Yes Is Question Mandatory : No Option Orientation : Vertical Correct Marks : 1 Wrong Marks : 0

The industrial controller having the best steady-state accuracy is

Options :

1. ✔ An Integral controller
2. ✘

A derivative controller

3. ✘ A rate feedback controller

4. ✘ A proportional controller

Question Number : 169 Question Id : 80089420014 Question Type : MCQ Option Shuffling : Yes Display Question Number : Yes Is Question Mandatory : No Option Orientation : Vertical Correct Marks : 1 Wrong Marks : 0

The variable which is modified to reach processes output at set value is known as

Options :

1. ✘ Controlled variable

2. ✔ Manipulated variable

3. ✘ Load variable

4. ✘ Normal variable

Question Number : 170 Question Id : 80089420015 Question Type : MCQ Option Shuffling : Yes Display Question Number : Yes Is Question Mandatory : No Option Orientation : Vertical Correct Marks : 1 Wrong Marks : 0

Which of the following is a three mode controller?

Options :

1. ✘ Proportional controller

2. ✘ ON-OFF controller
3. ✘ Integral controller
4. ✔ PID controller

Question Number : 171 Question Id : 80089420016 Question Type : MCQ Option Shuffling : Yes Display Question Number : Yes Is Question Mandatory : No Option Orientation : Vertical Correct Marks : 1 Wrong Marks : 0

Cascade controller consist of

Options :

1. ✘ Primary controller only
2. ✘ Secondary controller only
3. ✔ Both primary and secondary controller
4. ✘ Ratio controller

Question Number : 172 Question Id : 80089420017 Question Type : MCQ Option Shuffling : Yes Display Question Number : Yes Is Question Mandatory : No Option Orientation : Vertical Correct Marks : 1 Wrong Marks : 0

Which of the following control action has long period of oscillation?

Options :

1. ✔ PI type

2. ✘ P type
3. ✘ PD type
4. ✘ PID type

Question Number : 173 Question Id : 80089420018 Question Type : MCQ Option Shuffling : Yes Display Question Number : Yes Is Question Mandatory : No Option Orientation : Vertical Correct Marks : 1 Wrong Marks : 0

The motor gives discrete steps of rotation is known as

Options :

1. ✘ Servomotor
2. ✘ A.C motor
3. ✔ Stepper motor
4. ✘ D.C motor

Question Number : 174 Question Id : 80089420019 Question Type : MCQ Option Shuffling : Yes Display Question Number : Yes Is Question Mandatory : No Option Orientation : Vertical Correct Marks : 1 Wrong Marks : 0

Which of the following component configurations completely forms a Current to Pressure converter?

Options :

1. ✘ Flapper & Nozzle
2. ✘ Flapper, Nozzle & Spring

3. ✓ Flapper, Nozzle, Spring & Pivot

4. ✗ Flapper, Nozzle & Pivot

Question Number : 175 Question Id : 80089420020 Question Type : MCQ Option Shuffling : Yes

Display Question Number : Yes Is Question Mandatory : No Option Orientation : Vertical

Correct Marks : 1 Wrong Marks : 0

The standard current signal range in process industries

Options :

1. ✗ 0- 20 mA

2. ✗ 3-15 mA

3. ✓ 4-20 mA

4. ✗ 0-15mA

Question Number : 176 Question Id : 80089420021 Question Type : MCQ Option Shuffling : Yes

Display Question Number : Yes Is Question Mandatory : No Option Orientation : Vertical

Correct Marks : 1 Wrong Marks : 0

Which of the following statement is Correct?

Options :

1. ✓ Feed forward control system is used to minimize the deviation of the controlled variable

2. ✗ Feed forward control system is used to maximize the deviation of the controlled variable

3. ✘ Feed forward control system acts after the output is disturbed

4. ✘ In cascade control configuration, there is one manipulated variable and only one measurement

Question Number : 177 Question Id : 80089420022 Question Type : MCQ Option Shuffling : Yes

Display Question Number : Yes Is Question Mandatory : No Option Orientation : Vertical

Correct Marks : 1 Wrong Marks : 0

Solenoid valve operated with the signal of

Options :

1. ✔ Electrical

2. ✘ Mechanical

3. ✘ Thermal

4. ✘ Pneumatic

Question Number : 178 Question Id : 80089420023 Question Type : MCQ Option Shuffling : Yes

Display Question Number : Yes Is Question Mandatory : No Option Orientation : Vertical

Correct Marks : 1 Wrong Marks : 0

A P/I converter displays current value as 18mA. The corresponding pressure is

Options :

1. ✘ 14.5 psi

2. ✔ 13.5 psi

3. ✘ 16 psi

4. ✘ 18 psi

Question Number : 179 Question Id : 80089420024 Question Type : MCQ Option Shuffling : Yes

Display Question Number : Yes Is Question Mandatory : No Option Orientation : Vertical

Correct Marks : 1 Wrong Marks : 0

Which of the following statements is not true for an integrated circuit?

Options :

1. ✘ Integrated circuits are basically microelectronic circuit

2. ✘ Integrated circuits connect all components

3. ✘ Integrated circuits are very small in size

4. ✔ Integrated circuits consists only of active circuit components

Question Number : 180 Question Id : 80089420025 Question Type : MCQ Option Shuffling : Yes

Display Question Number : Yes Is Question Mandatory : No Option Orientation : Vertical

Correct Marks : 1 Wrong Marks : 0

In medium scale Integration number of components are

Options :

1. ✘ <10

2. ✘ <100

3. ✓ >100

4. ✗ >1000

Question Number : 181 Question Id : 80089420026 Question Type : MCQ Option Shuffling : Yes

Display Question Number : Yes Is Question Mandatory : No Option Orientation : Vertical

Correct Marks : 1 Wrong Marks : 0

Logic gate is an example of

Options :

1. ✓ Small-scale integrated circuits (SSI)

2. ✗ Medium-scale integrated circuits (MSI)

3. ✗ Large-scale integrated circuits (LSI)

4. ✗ Very-large scale integrated circuits (VLSI)

Question Number : 182 Question Id : 80089420027 Question Type : MCQ Option Shuffling : Yes

Display Question Number : Yes Is Question Mandatory : No Option Orientation : Vertical

Correct Marks : 1 Wrong Marks : 0

Unit for slew rate of Op-Amp is

Options :

1. ✗ $\mu\text{s}/\text{V}$

2. ✓ $\text{V}/\mu\text{s}$

3. ✘ $I/\mu s$

4. ✘ $\mu s/I$

Question Number : 183 Question Id : 80089420028 Question Type : MCQ Option Shuffling : Yes

Display Question Number : Yes Is Question Mandatory : No Option Orientation : Vertical

Correct Marks : 1 Wrong Marks : 0

An RS flip-flop is an integral part of

Options :

1. ✔ IC 555

2. ✘ IC 741

3. ✘ MC 1741

4. ✘ IC 78XX

Question Number : 184 Question Id : 80089420029 Question Type : MCQ Option Shuffling : Yes

Display Question Number : Yes Is Question Mandatory : No Option Orientation : Vertical

Correct Marks : 1 Wrong Marks : 0

The relation between input voltage and output voltage of the following circuit if $R_a=R_b=R_c$ is

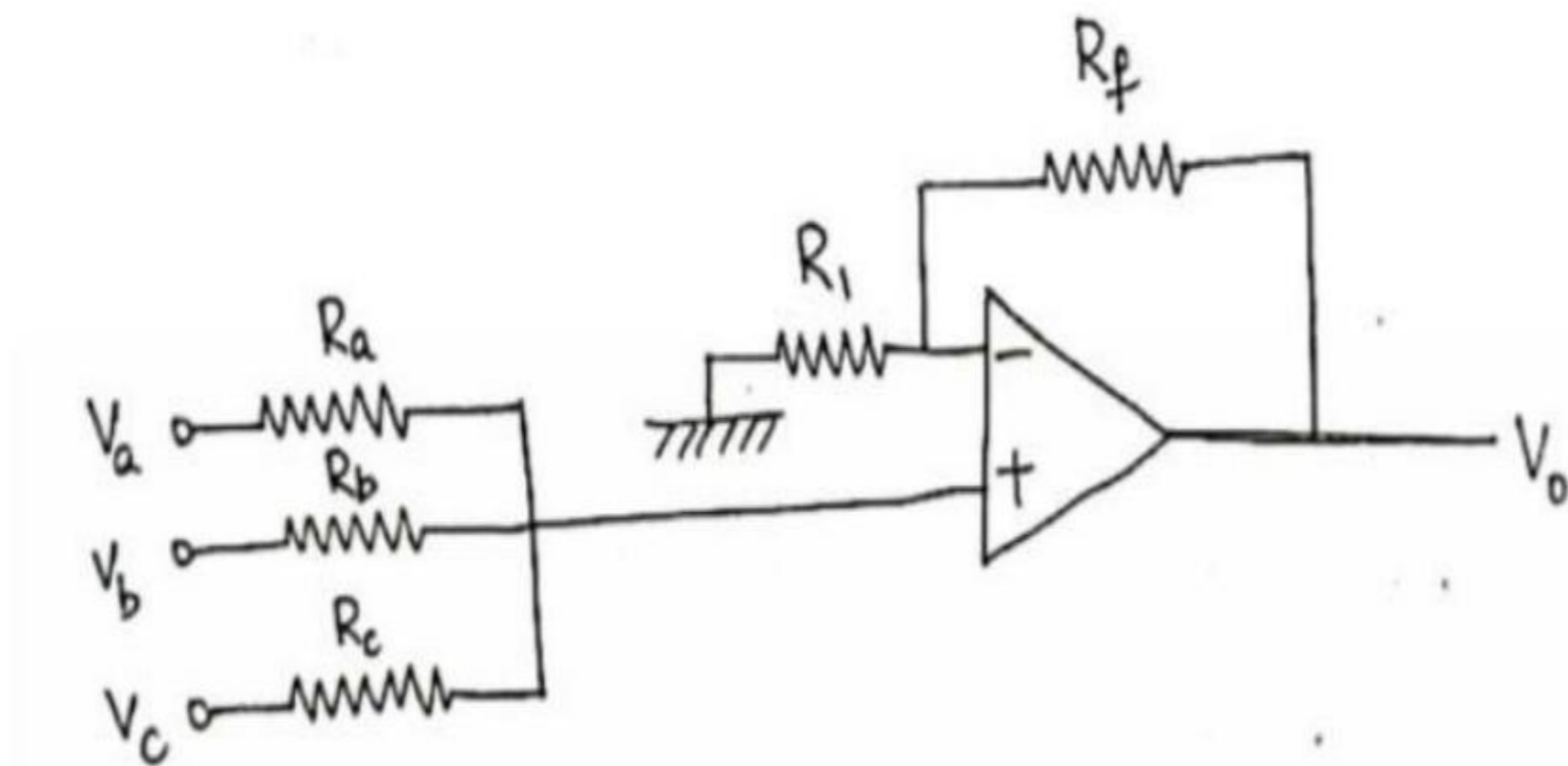

Options :

1. ✘ $\frac{R_f}{R_1} \left(\frac{V_a + V_b + V_c}{3} \right)$

2. ✔ $\left(1 + \frac{R_f}{R_1} \right) \left(\frac{V_a + V_b + V_c}{3} \right)$

3. ✘ $-\left(\frac{R_f}{R_1} \right) \left(\frac{V_a + V_b + V_c}{3} \right)$

4. ✘ $\left(1 - \frac{R_f}{R_1} \right) \left(\frac{V_a + V_b + V_c}{3} \right)$

Question Number : 185 Question Id : 80089420030 Question Type : MCQ Option Shuffling : Yes

Display Question Number : Yes Is Question Mandatory : No Option Orientation : Vertical

Correct Marks : 1 Wrong Marks : 0

An operational amplifier (op-amp) is basically a _____ amplifier

Options :

1. ✔ Negative feedback

2. ✘ Low input impedance

3. ✘ Low-gain

4. ✘ Low band width

Question Number : 186 Question Id : 80089420031 Question Type : MCQ Option Shuffling : Yes

Display Question Number : Yes Is Question Mandatory : No Option Orientation : Vertical

Correct Marks : 1 Wrong Marks : 0

With usual notations, the duty cycle of Astable Multivibrator is given by

Options :

1. ✔ $\frac{R_A + R_B}{R_A + 2R_B}$

2. ✘ $\frac{R_A + 2R_B}{R_A + R_B}$

3. ✘ $\frac{R_A}{R_A + R_B}$

4. ✘ $\frac{R_A}{R_A + 2R_B}$

Question Number : 187 Question Id : 80089420032 Question Type : MCQ Option Shuffling : Yes

Display Question Number : Yes Is Question Mandatory : No Option Orientation : Vertical

Correct Marks : 1 Wrong Marks : 0

A monostable multivibrator is also called a

Options :

1. ✘ Flip-flop
2. ✘ Clock
3. ✔ One shot multivibrator
4. ✘ Free running multivibrator

Question Number : 188 Question Id : 80089420033 Question Type : MCQ Option Shuffling : Yes Display Question Number : Yes Is Question Mandatory : No Option Orientation : Vertical Correct Marks : 1 Wrong Marks : 0

The Number of pins available in 78xx regulator are ?

Options :

1. ✔ 3
2. ✘ 4
3. ✘ 2
4. ✘ 5

Question Number : 189 Question Id : 80089420034 Question Type : MCQ Option Shuffling : Yes Display Question Number : Yes Is Question Mandatory : No Option Orientation : Vertical Correct Marks : 1 Wrong Marks : 0

8051 is a

Options :

1. ✘ 16 bit microcontroller
2. ✔ 8 bit microcontroller
3. ✘ 32 bit microcontroller
4. ✘ 4 bit microcontroller

Question Number : 190 Question Id : 80089420035 Question Type : MCQ Option Shuffling : Yes

Display Question Number : Yes Is Question Mandatory : No Option Orientation : Vertical

Correct Marks : 1 Wrong Marks : 0

8051 microcontroller has memory ROM, RAM size

Options :

1. ✔ 4 KB of ROM , 128 bytes of RAM
2. ✘ 128 bytes of ROM , 4 KB of RAM
3. ✘ 4 KB of ROM , 1KB bytes of RAM
4. ✘ 2 KB of ROM , 128 bytes of RAM

Question Number : 191 Question Id : 80089420036 Question Type : MCQ Option Shuffling : Yes

Display Question Number : Yes Is Question Mandatory : No Option Orientation : Vertical

Correct Marks : 1 Wrong Marks : 0

Which of the following Mnemonic corresponds to register addressing mode in 8051 Microcontroller?

Options :

1. ✘ MOV @ R0, 80h
2. ✘ MOV @ R1, A
3. ✔ MOV R5, A
4. ✘ MOV add, A

Question Number : 192 Question Id : 80089420037 Question Type : MCQ Option Shuffling : Yes

Display Question Number : Yes Is Question Mandatory : No Option Orientation : Vertical

Correct Marks : 1 Wrong Marks : 0

Integration of processor with necessary peripherals on a single chip is known as

Options :

1. ✘ Microprocessor
2. ✔ Micro controller
3. ✘ PLC
4. ✘ SCADA

Question Number : 193 Question Id : 80089420038 Question Type : MCQ Option Shuffling : Yes

Display Question Number : Yes Is Question Mandatory : No Option Orientation : Vertical

Correct Marks : 1 Wrong Marks : 0

How many addresses are in 8255 interfacing peripheral?

Options :

1. ✘ 2

2. ✓ 3

3. ✗ 4

4. ✗ 5

Question Number : 194 Question Id : 80089420039 Question Type : MCQ Option Shuffling : Yes

Display Question Number : Yes Is Question Mandatory : No Option Orientation : Vertical

Correct Marks : 1 Wrong Marks : 0

8051 Microcontroller is used in which of the following application?

Options :

1. ✓ Automatic water level maintenance

2. ✗ Calculators

3. ✗ Accounting systems

4. ✗ Laser Printer

Question Number : 195 Question Id : 80089420040 Question Type : MCQ Option Shuffling : Yes

Display Question Number : Yes Is Question Mandatory : No Option Orientation : Vertical

Correct Marks : 1 Wrong Marks : 0

Programming method most widely used in PLC's are

Options :

1. ✗ Instruction set

2. ✓ Ladder diagram

3. ✘ FBD

4. ✘ Assembly language

**Question Number : 196 Question Id : 80089420041 Question Type : MCQ Option Shuffling : Yes
Display Question Number : Yes Is Question Mandatory : No Option Orientation : Vertical
Correct Marks : 1 Wrong Marks : 0**

Which of the following statement is Correct with respect to PLC?

Options :

1. ✘ The latch instruction is often called as RES (reset)

2. ✘ The Set instruction causes the relay not to self hold

3. ✓ Retentive relays retain their state of activation, even when the power supply is Off

4. ✘ HSC is one of the low speed counter instruction

**Question Number : 197 Question Id : 80089420042 Question Type : MCQ Option Shuffling : Yes
Display Question Number : Yes Is Question Mandatory : No Option Orientation : Vertical
Correct Marks : 1 Wrong Marks : 0**

Which of the following is not SCADA element?

Options :

1. ✘ Sensor

2. ✘ Actuator

3. ✘ PLC

4. ✔ CNC

Question Number : 198 Question Id : 80089420043 Question Type : MCQ Option Shuffling : Yes

Display Question Number : Yes Is Question Mandatory : No Option Orientation : Vertical

Correct Marks : 1 Wrong Marks : 0

Which of the following is a part of PLC architecture?

Options :

1. ✘ Actuator

2. ✘ Motor

3. ✘ Graphical code

4. ✔ Input sensing module

Question Number : 199 Question Id : 80089420044 Question Type : MCQ Option Shuffling : Yes

Display Question Number : Yes Is Question Mandatory : No Option Orientation : Vertical

Correct Marks : 1 Wrong Marks : 0

which of the following is a programmable peripheral interface (PPI) ?

Options :

1. ✘ 8085

2. ✘ 8051

3. ✓ 8255

4. ✘ 8086

Question Number : 200 Question Id : 80089420045 Question Type : MCQ Option Shuffling : Yes

Display Question Number : Yes Is Question Mandatory : No Option Orientation : Vertical

Correct Marks : 1 Wrong Marks : 0

What will be the outcome of the ladder logic program shown below?

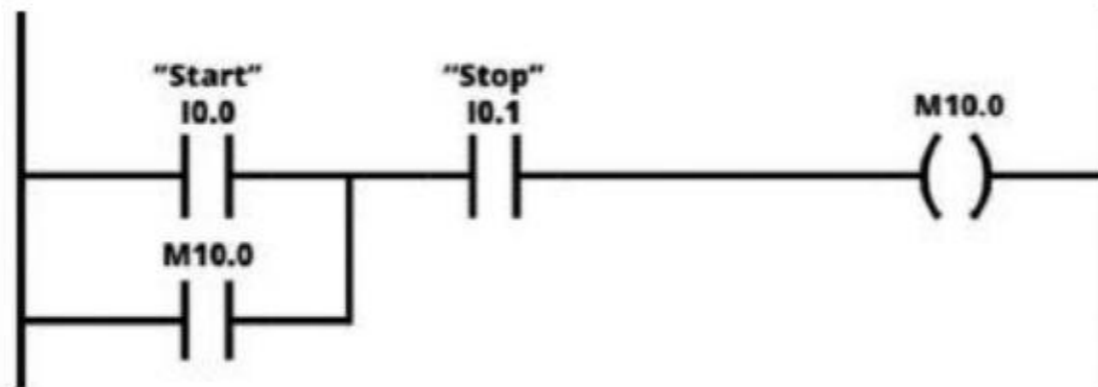

Options :

1. ✓ The Motor (M10.0) can be ON/OFF by single push button

2. ✘ The Motor (M10.0) can be ON/OFF by two push button

3. ✘ The Motor (M10.0) can only be ON by single push button

4. ✘ The Motor (M10.0) can only be OFF by single push button