

National Testing Agency

Question Paper Name:	Paper I EHG 12th Jan 2019 Shift 2
Subject Name:	Paper I EHG
Creation Date:	2019-01-13 00:46:26
Duration:	180
Total Marks:	360
Display Marks:	Yes

Paper I

Group Number :	1
Group Id :	416529124
Group Maximum Duration :	0
Group Minimum Duration :	180
Revisit allowed for view? :	No
Revisit allowed for edit? :	No
Break time:	0
Group Marks:	360

Physics

Section Id :	416529154
Section Number :	1
Section type :	Online
Mandatory or Optional:	Mandatory
Number of Questions:	30
Number of Questions to be attempted:	30
Section Marks:	120
Display Number Panel:	Yes
Group All Questions:	No

Sub-Section Number:	1
Sub-Section Id:	416529163
Question Shuffling Allowed :	Yes

Question Number : 1 Question Type : MCQ Option Shuffling : Yes Display Question Number : Yes Single Line Question Option : No Option Orientation : Vertical

Correct Marks : 4 Wrong Marks : 1

Let l , r , c and v represent inductance, resistance, capacitance and voltage,

respectively. The dimension of $\frac{l}{rcv}$ in SI

units will be :

Options :

- [LTA]

2. $[A^{-1}]$

3. $[LT^2]$

4. $[LA^{-2}]$

Question Number : 1 Question Type : MCQ Option Shuffling : Yes Display Question Number : Yes Single Line Question Option : No Option Orientation : Vertical

Correct Marks : 4 Wrong Marks : 1

माना l, r, c व v क्रमशः प्रेरकत्व, प्रतिरोध, धारिता व

विभव को दर्शाते हैं। $\frac{l}{rcv}$ की विमा SI मात्रकों में

होगी :

Options :

1. $[LTA]$

2. $[A^{-1}]$

3. $[LT^2]$

4. $[LA^{-2}]$

Question Number : 1 Question Type : MCQ Option Shuffling : Yes Display Question Number : Yes Single Line Question Option : No Option Orientation : Vertical

Correct Marks : 4 Wrong Marks : 1

l, r, c અને v અનુક્રમે પ્રેરણ, અવરોધ, સંગ્રાહકતા

(કેપેસિટન્સ) અને વોલ્ટેજ રજૂ કરે છે. $\frac{l}{rcv}$ નો SI

એકમ પદ્ધતીમાં પરિમાણ :

Options :

1. $[LTA]$

2. $[A^{-1}]$

3. $[LT^2]$

4. $[LA^{-2}]$

Question Number : 2 Question Type : MCQ Option Shuffling : Yes Display Question Number : Yes Single Line Question Option : No Option Orientation : Vertical

Correct Marks : 4 Wrong Marks : 1

Two particles A, B are moving on two concentric circles of radii R_1 and R_2 with equal angular speed ω . At $t=0$, their positions and direction of motion are shown in the figure :

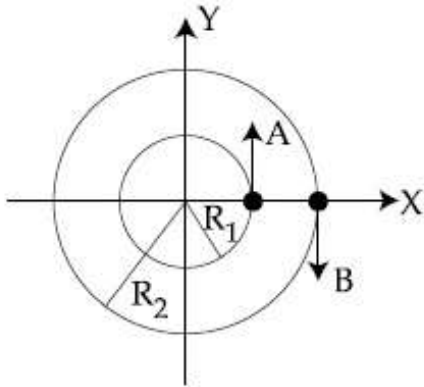

The relative velocity $\vec{v}_A - \vec{v}_B$ at $t = \frac{\pi}{2\omega}$ is given by :

Options :

1. $\omega(R_1 - R_2)\hat{i}$

2. $\omega(R_2 - R_1)\hat{i}$

3. $-\omega(R_1 + R_2)\hat{i}$

4. $\omega(R_1 + R_2)\hat{i}$

Question Number : 2 Question Type : MCQ Option Shuffling : Yes Display Question Number : Yes Single Line Question Option : No Option Orientation : Vertical Correct Marks : 4 Wrong Marks : 1

दो कण, A एवं B, बराबर कोणीय वेग ω से R_1 एवं R_2 त्रिज्या के दो समकेन्द्रित वृत्तों पर चल रहे हैं। समय $t=0$ पर उनकी गति की दिशाएँ एवं स्थितियों को चित्र में दिखाया गया है।

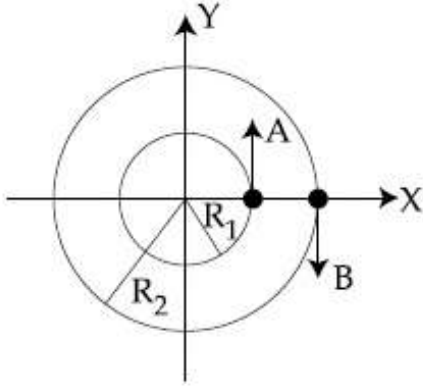

$t = \frac{\pi}{2\omega}$ पर सापेक्ष वेग $\vec{v}_A - \vec{v}_B$ होगा :

Options :

1. $\omega(R_1 - R_2)\hat{i}$

2. $\omega(R_2 - R_1)\hat{i}$

3. $-\omega(R_1 + R_2)\hat{i}$

4. $\omega(R_1 + R_2)\hat{i}$

Question Number : 2 Question Type : MCQ Option Shuffling : Yes Display Question Number : Yes Single Line Question Option : No Option Orientation : Vertical

Correct Marks : 4 Wrong Marks : 1

બે કણો A અને B, ω જેટલી સમાન કોણીય ઝડપ સાથે R_1 અને R_2 જેટલી ત્રિજ્યાઓ ધરાવતા બે સમકેન્દ્રીય વર્તુળો પર ગતિ કરે છે. $t=0$ સમયે તેમના સ્થાન અને ગતિની દિશા આકૃતિમાં દર્શાવેલ છે.

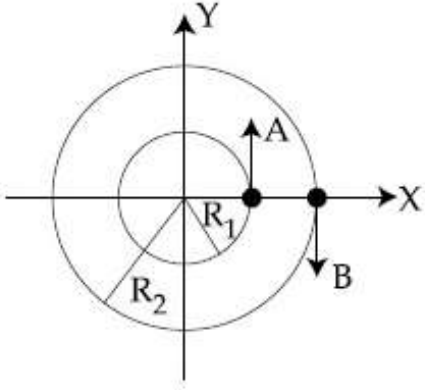

$t = \frac{\pi}{2\omega}$ સમયે સાપેક્ષ વેગ $\vec{v}_A - \vec{v}_B$ _____

થી આપી શકાય.

Options :

1. $\omega(R_1 - R_2)\hat{i}$
2. $\omega(R_2 - R_1)\hat{i}$
3. $-\omega(R_1 + R_2)\hat{i}$
4. $\omega(R_1 + R_2)\hat{i}$

Question Number : 3 Question Type : MCQ Option Shuffling : Yes Display Question Number : Yes Single Line Question Option : No Option Orientation : Vertical

Correct Marks : 4 Wrong Marks : 1

A block kept on a rough inclined plane, as shown in the figure, remains at rest upto a maximum force 2 N down the inclined plane. The maximum external force up the inclined plane that does not move the block is 10 N. The coefficient of static friction between the block and the plane is :

[Take $g = 10 \text{ m/s}^2$]

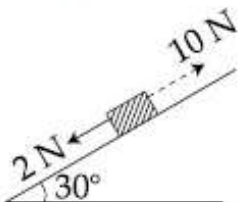

Options :

1. $\frac{1}{2}$

2. $\frac{\sqrt{3}}{4}$

3. $\frac{2}{3}$

4. $\frac{\sqrt{3}}{2}$

Question Number : 3 Question Type : MCQ Option Shuffling : Yes Display Question Number : Yes Single Line Question Option : No Option Orientation : Vertical

Correct Marks : 4 Wrong Marks : 1

चित्रानुसार, एक खुरदरे आनत तल पर, एक गुटका रखा है। यदि गुटके पर समतल के समदिश व नीचे की ओर 2 N मान तक का बल लगाया जाता है तो गुटका स्थिर रहता है। ऐसा बल जब ऊपर की ओर लगाते हैं तो 10 N बल के मान तक गुटका स्थिर रहता है। गुटके व समतल के बीच घर्षण गुणांक का मान होगा :

$[g = 10 \text{ m/s}^2]$

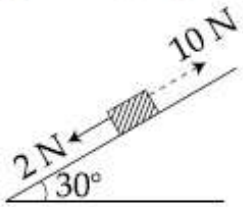

Options :

1. $\frac{1}{2}$

2. $\frac{\sqrt{3}}{4}$

3. $\frac{2}{3}$

4. $\frac{\sqrt{3}}{2}$

Question Number : 3 Question Type : MCQ Option Shuffling : Yes Display Question Number : Yes No Option Orientation : Vertical

Correct Marks : 4 Wrong Marks : 1

આકૃતિમાં દર્શાવ્યા અનુસાર એક ખરબચડા ઢળતા સમતલ (પાટિયા) પર મુકેલ ચોસલું, ઢળતા સમતલથી નીચે તરફ લાગતા 2 N જેટલા મહત્તમ બળની સામે સ્થિર રહે છે. બ્લોક (ચોસલું) ખસે નહીં તે રીતે ઢળતા સમતલની ઊપર તરફ લાગતું મહત્તમ બાહ્ય બળ 10 N છે. ચોસલા અને સમતલ વચ્ચે સ્થિત ઘર્ષણાંક હશે :
[$g = 10 \text{ m/s}^2$]

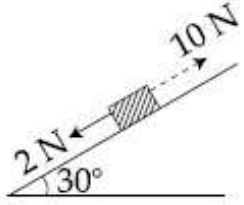

Options :

1. $\frac{1}{2}$

2. $\frac{\sqrt{3}}{4}$

3. $\frac{2}{3}$

4. $\frac{\sqrt{3}}{2}$

Question Number : 4 Question Type : MCQ Option Shuffling : Yes Display Question Number : Yes Single Line Question Option : No Option Orientation : Vertical

Correct Marks : 4 Wrong Marks : 1

An alpha-particle of mass m suffers 1-dimensional elastic collision with a nucleus at rest of unknown mass. It is scattered directly backwards losing, 64% of its initial kinetic energy. The mass of the nucleus is :

Options :

1. $4m$

2. $3.5m$

3. $2m$

4. $1.5m$

Question Number : 4 Question Type : MCQ Option Shuffling : Yes Display Question Number : Yes Single Line Question Option : No Option Orientation : Vertical

Correct Marks : 4 Wrong Marks : 1

एक m द्रव्यमान का अल्फा कण किसी अज्ञात द्रव्यमान के स्थिर नाभिक से एक-विमीय प्रत्यास्थ संघट्ट करके अपनी प्रारंभिक गतिज ऊर्जा का 64% भाग क्षय करके ठीक विपरीत दिशा में प्रकीर्णित हो जाता है। नाभिक का द्रव्यमान होगा :

Options :

1. 4 m
2. 3.5 m
3. 2 m
4. 1.5 m

Question Number : 4 Question Type : MCQ Option Shuffling : Yes Display Question Number : Yes Single Line Question Option : No Option Orientation : Vertical

Correct Marks : 4 Wrong Marks : 1

m द्रव्यमान का एक अल्फा-कण को अज्ञात द्रव्यमान धरावता स्थिर न्युक्लियस साथे एक-पारिभाषीय स्थितिस्थापक अथवा अनुभव है, अने तेनी प्रारंभिक गतिज ऊर्जा का 64% गुणावी ठीक पाछणी दिशां प्रकीर्णित थाय है. न्युक्लियसनुं द्रव्य हसे :

Options :

1. 4 m
2. 3.5 m
3. 2 m
4. 1.5 m

Question Number : 5 Question Type : MCQ Option Shuffling : Yes Display Question Number : Yes Single Line Question Option : No Option Orientation : Vertical

Correct Marks : 4 Wrong Marks : 1

A particle of mass 20 g is released with an initial velocity 5 m/s along the curve from the point A, as shown in the figure. The point A is at height h from point B. The particle slides along the frictionless surface. When the particle reaches point B, its angular momentum about O will be :

(Take $g = 10 \text{ m/s}^2$)

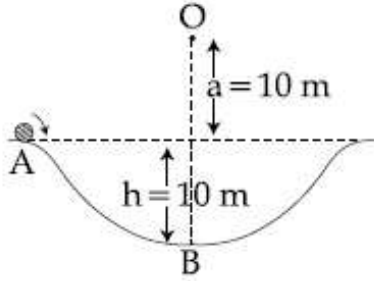

Options :

1. $6 \text{ kg-m}^2/\text{s}$
2. $8 \text{ kg-m}^2/\text{s}$
3. $2 \text{ kg-m}^2/\text{s}$
4. $3 \text{ kg-m}^2/\text{s}$

Question Number : 5 Question Type : MCQ Option Shuffling : Yes Display Question Number : Yes Single Line Question Option : No Option Orientation : Vertical

Correct Marks : 4 Wrong Marks : 1

चित्रानुसार 20 g द्रव्यमान के एक कण को 5 m/s व
वक्र के अनुगत आरम्भिक वेग से बिन्दु A से छोड़ा
जाता है। बिन्दु A की बिन्दु B से ऊँचाई h है। यह कण
घर्षणहीन पृष्ठ पर सरकता है। जब कण बिन्दु B पर
पहुँचता है, तो इसका बिन्दु O के सापेक्ष कोणीय संवेग
क्या होगा ?

(दिया है : $g = 10 \text{ m/s}^2$)

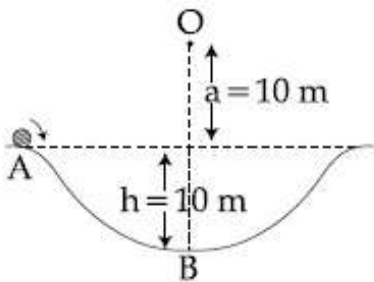

Options :

1. $6 \text{ kg-m}^2/\text{s}$

2. $8 \text{ kg-m}^2/\text{s}$
3. $2 \text{ kg-m}^2/\text{s}$
4. $3 \text{ kg-m}^2/\text{s}$

Question Number : 5 Question Type : MCQ Option Shuffling : Yes Display Question Number : Yes Single Line Question Option : No Option Orientation : Vertical

Correct Marks : 4 Wrong Marks : 1

એક 20 g દળ ધરાવતા કણને આકૃતિમાં દર્શાવ્યા અનુસાર બિંદુ B થી h ઊંચાઈ એ આવેલા બિંદુ A આગળથી 5 m/s જેટલા પ્રારંભિક વેગ સાથે મુક્ત કરવામાં આવે છે. કણ ઘર્ષણ રહિત સપાટી પર સરકે છે. કણ જ્યારે બિંદુ B આગળ પહોંચે છે, ત્યારે તેનું O ની સાપેક્ષ કોણીય વેગમાન _____ થશે.

($g = 10 \text{ m/s}^2$ લો.)

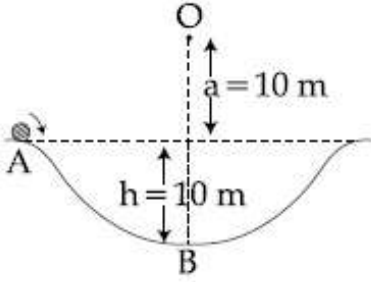

Options :

1. $6 \text{ kg-m}^2/\text{s}$
2. $8 \text{ kg-m}^2/\text{s}$
3. $2 \text{ kg-m}^2/\text{s}$
4. $3 \text{ kg-m}^2/\text{s}$

Question Number : 6 Question Type : MCQ Option Shuffling : Yes Display Question Number : Yes Single Line Question Option : No Option Orientation : Vertical

Correct Marks : 4 Wrong Marks : 1

The moment of inertia of a solid sphere, about an axis parallel to its diameter and at a distance of x from it, is ' $I(x)$ '. Which one of the graphs represents the variation of $I(x)$ with x correctly ?

Options :

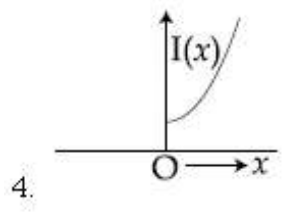
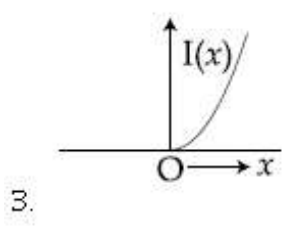
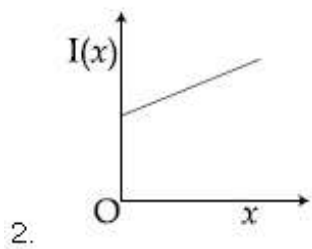
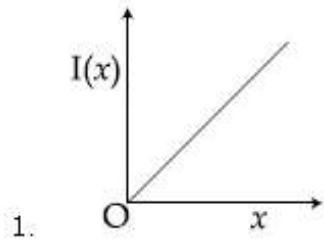

Question Number : 6 Question Type : MCQ Option Shuffling : Yes Display Question Number : Yes Single Line Question Option : No Option Orientation : Vertical

Correct Marks : 4 Wrong Marks : 1

एक ठोस गोले का जड़त्व आघूर्ण, एक अक्ष के सापेक्ष, जो उसके व्यास के समान्तर तथा उससे x दूरी पर है, $I(x)$ है। निम्न में से कौन सा ग्राफ $I(x)$ का x के साथ परिवर्तन को सही दर्शाता है?

Options :

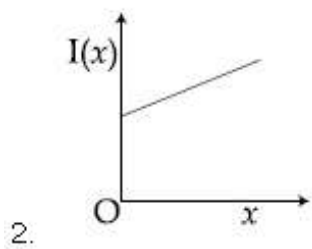
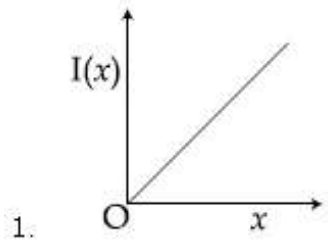

3.

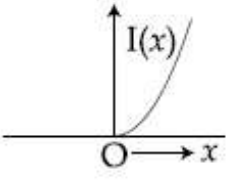

4.

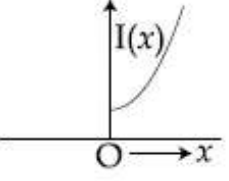

Question Number : 6 Question Type : MCQ Option Shuffling : Yes Display Question Number : Yes Single Line Question Option : No Option Orientation : Vertical

Correct Marks : 4 Wrong Marks : 1

એક ઘન ગોળાની તેના વ્યાસને સમાંતર અને તેનાથી x અંતરે રહેલ અક્ષને અનુલક્ષીને જડત્વની ચાકમાત્રા $I(x)$ છે. નીચે આપેલા આલેખો પૈકી કયો આલેખ $I(x)$ નું x સાથેનો ફેરફાર સાચી રીતે દર્શાવે છે ?

Options :

1.

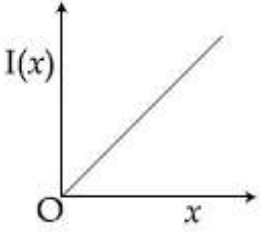

2.

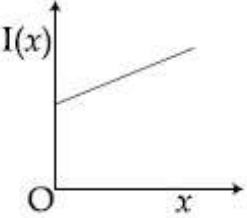

3.

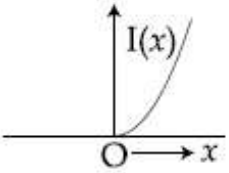

4.

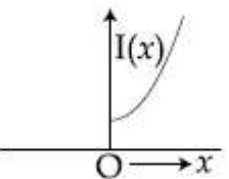

Question Number : 7 Question Type : MCQ Option Shuffling : Yes Display Question Number : Yes No Option Orientation : Vertical

Correct Marks : 4 Wrong Marks : 1

Two satellites, A and B, have masses m and $2m$ respectively. A is in a circular orbit of radius R , and B is in a circular orbit of radius $2R$ around the earth. The ratio of their kinetic energies, T_A/T_B , is :

Options :

1. 2
2. $\frac{1}{2}$
3. 1
4. $\sqrt{\frac{1}{2}}$

Question Number : 7 Question Type : MCQ Option Shuffling : Yes Display Question Number : Yes Single Line Question Option : No Option Orientation : Vertical

Correct Marks : 4 Wrong Marks : 1

दो उपग्रहों, A और B, के द्रव्यमान क्रमशः m एवं $2m$ हैं। पृथ्वी के परितः A, त्रिज्या R के वृत्ताकार कक्ष में तथा, B त्रिज्या $2R$ के वृत्ताकार कक्षा में चल रहे हैं। उपग्रहों की गतिज ऊर्जाओं के अनुपात, T_A/T_B का मान होगा :

Options :

1. 2
2. $\frac{1}{2}$
3. 1
4. $\sqrt{\frac{1}{2}}$

Question Number : 7 Question Type : MCQ Option Shuffling : Yes Display Question Number : Yes Single Line Question Option : No Option Orientation : Vertical

Correct Marks : 4 Wrong Marks : 1

બે ઉપગ્રહો A અને B ના દળો અનુક્રમે m અને $2m$ છે. પૃથ્વીને ફરતે, A એ R ત્રિજ્યાની વર્તુળાકાર કક્ષા અને B એ $2R$ ત્રિજ્યાની વર્તુળાકાર કક્ષામાં છે. તેની ગતિ ઊર્જાઓનો ગુણોત્તર T_A/T_B _____ છે.

Options :

1. 2

2. $\frac{1}{2}$

3. 1

4. $\sqrt{\frac{1}{2}}$

Question Number : 8 Question Type : MCQ Option Shuffling : Yes Display Question Number : Yes Single Line Question Option : No Option Orientation : Vertical

Correct Marks : 4 Wrong Marks : 1

A long cylindrical vessel is half filled with a liquid. When the vessel is rotated about its own vertical axis, the liquid rises up near the wall. If the radius of vessel is 5 cm and its rotational speed is 2 rotations per second, then the difference in the heights between the centre and the sides, in cm, will be :

Options :

1. 0.4

2. 0.1

3. 2.0

4. 1.2

Question Number : 8 Question Type : MCQ Option Shuffling : Yes Display Question Number : Yes Single Line Question Option : No Option Orientation : Vertical

Correct Marks : 4 Wrong Marks : 1

एक लंबे बेलनाकार पात्र द्रव से आधा भरा हुआ है। जब पात्र को अपनी ऊर्ध्व अक्ष के संगत घुमाते हैं तो, द्रव पात्र की दीवार के समीप ऊपर उठता है। यदि पात्र की त्रिज्या 5 cm तथा इसकी घूर्णन गति 2 चक्कर प्रति सेकेण्ड है, तो पात्र के मध्य तथा किनारे पर द्रव की ऊँचाई में अन्तर का मान cm में, होगा :

Options :

1. 0.4

2. 0.1

3. 2.0

4. 1.2

Question Number : 8 Question Type : MCQ Option Shuffling : Yes Display Question Number : Yes Single Line Question Option : No Option Orientation : Vertical

Correct Marks : 4 Wrong Marks : 1

કોઈ જંબે નળાકારીય પાત્રમાં પ્રવાહી આધા ભરેલ છે. જ્યારે પાત્ર પોતાની ઉર્ધ્વ અક્ષને અનુલક્ષીને પરિભ્રમણ કરે છે ત્યારે દિવાલની નજીક (અડીને) પ્રવાહી ઊપર ચઢે છે. જો પાત્રની ત્રિજ્યા 5 cm અને તેની ચાક ઝડપ 2 ભ્રમણ પ્રતિ સેકન્ડ હોય તો તેના કેન્દ્ર (મધ્યભાગ) અને છેડાની વચ્ચે ઊંચાઈનો તફાવત, cm માં, _____ હશે.

Options :

1. 0.4

2. 0.1

3. 2.0

4. 1.2

Question Number : 9 Question Type : MCQ Option Shuffling : Yes Display Question Number : Yes Single Line Question Option : No Option Orientation : Vertical

Correct Marks : 4 Wrong Marks : 1

A soap bubble, blown by a mechanical pump at the mouth of a tube, increases in volume, with time, at a constant rate. The graph that correctly depicts the time dependence of pressure inside the bubble is given by :

Note: For this question, discrepancy is found in question/answer. Full Marks is being awarded to all candidates.

Options :

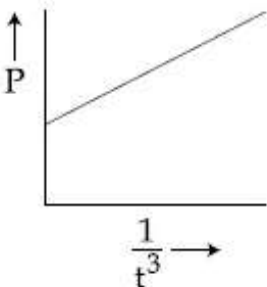

1.

2.

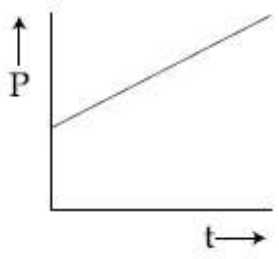

3.

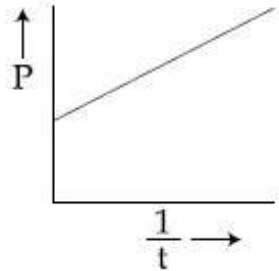

4.

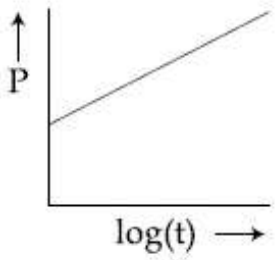

Question Number : 9 Question Type : MCQ Option Shuffling : Yes Display Question Number : Yes Single Line Question Option : No Option Orientation : Vertical

Correct Marks : 4 Wrong Marks : 1

एक नली के मुख पर एक यांत्रिक पम्प से फुलाकर एक साबुन के बुलबुले का आयतन, समय के साथ, एक स्थिर दर से बढ़ता है। निम्न ग्राफों में कौन, बुलबुले के अन्दर के दाब का समय के साथ बदलाव को, सही चित्रित करता है?

Note: For this question, discrepancy is found in question/answer. Full Marks is being awarded to all candidates.

Options :

1.

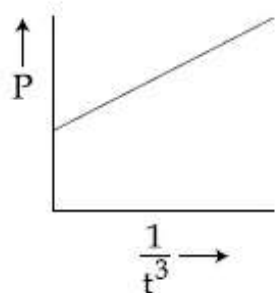

2.

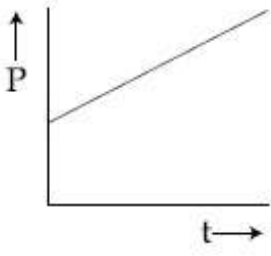

3.

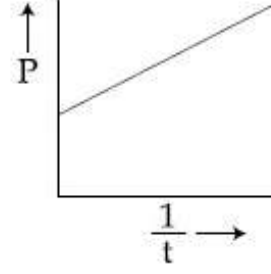

4.

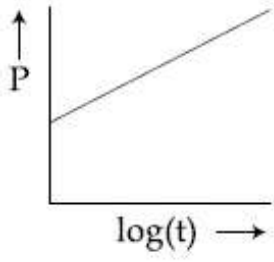

Question Number : 9 Question Type : MCQ Option Shuffling : Yes Display Question Number : Yes Single Line Question Option : No Option Orientation : Vertical

Correct Marks : 4 Wrong Marks : 1

એક યાંત્રિક પંપ વડે નળીના છેડા (મુખ) આગળ બનાવેલ સાબુના પરપોટાનું કદ એ અચળ દરે વધે છે. પરપોટાની અંદરના દબાણનું સમય પરનો આધાર સાચી રીતે દર્શાવતો આલેખ _____ મુજબ આપી શકાય.

Note: For this question, discrepancy is found in question/answer. Full Marks is being awarded to all candidates.

Options :

1.

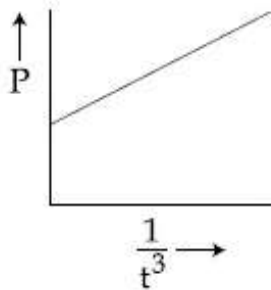

2.

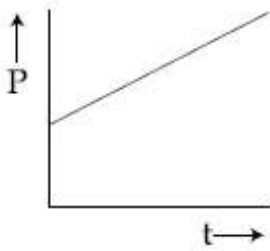

3.

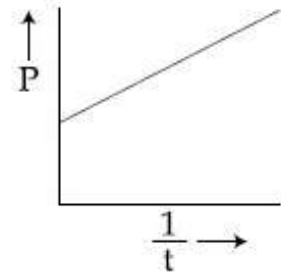

4.

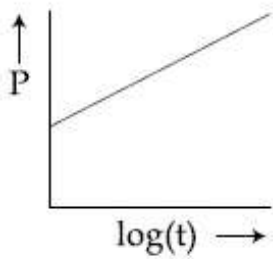

Question Number : 10 Question Type : MCQ Option Shuffling : Yes Display Question Number : Yes Single Line Question Option : No Option Orientation : Vertical

Correct Marks : 4 Wrong Marks : 1

A vertical closed cylinder is separated into two parts by a frictionless piston of mass m and of negligible thickness. The piston is free to move along the length of the cylinder. The length of the cylinder above the piston is l_1 , and that below the piston is l_2 , such that $l_1 > l_2$. Each part of the cylinder contains n moles of an ideal gas at equal temperature T . If the piston is stationary, its mass, m , will be given by :

(R is universal gas constant and g is the acceleration due to gravity)

Options :

1. $\frac{nRT}{g} \left[\frac{1}{l_2} + \frac{1}{l_1} \right]$

2. $\frac{nRT}{g} \left[\frac{l_1 - l_2}{l_1 l_2} \right]$

$$3. \frac{RT}{g} \left[\frac{2l_1 + l_2}{l_1 l_2} \right]$$

$$4. \frac{RT}{ng} \left[\frac{l_1 - 3l_2}{l_1 l_2} \right]$$

Question Number : 10 Question Type : MCQ Option Shuffling : Yes Display Question Number : Yes Single Line Question Option : No Option Orientation : Vertical

Correct Marks : 4 Wrong Marks : 1

गैस से भरे हुए एक बन्द ऊर्ध्वाधर बेलनाकार बर्तन को, एक घर्षणहीन एवं नगण्य मोटाई के, m द्रव्यमान के पिस्टन से दो भागों में बाँटते हैं। पिस्टन बेलन की लम्बाई के अनुदिश चलने को स्वतंत्र है। पिस्टन के ऊपर बेलन की लम्बाई l_1 और पिस्टन के नीचे की लम्बाई l_2 इस प्रकार है कि, $l_1 > l_2$ है। बेलन के प्रत्येक भाग में एक आदर्श गैस के n मोल समान तापमान T पर हैं। यदि पिस्टन स्थायी है तो इसके द्रव्यमान m का मान होगा :

(R , सार्वत्रिक गैस नियतांक तथा g , गुरुत्वीय त्वरण है)

Options :

$$1. \frac{nRT}{g} \left[\frac{1}{l_2} + \frac{1}{l_1} \right]$$

$$2. \frac{nRT}{g} \left[\frac{l_1 - l_2}{l_1 l_2} \right]$$

$$3. \frac{RT}{g} \left[\frac{2l_1 + l_2}{l_1 l_2} \right]$$

$$4. \frac{RT}{ng} \left[\frac{l_1 - 3l_2}{l_1 l_2} \right]$$

Question Number : 10 Question Type : MCQ Option Shuffling : Yes Display Question Number : Yes Single Line Question Option : No Option Orientation : Vertical

Correct Marks : 4 Wrong Marks : 1

એક ઉર્ધ્વ બંધ નળાકારને કોઈ m દળ ધરાવતા અને અવગણ્ય જડાઈ ધરાવતા ધર્ષણરહિત પિસ્ટન વડે બે ભાગમાં વહેંચવામાં આવે છે, કે જે નળાકારની લંબાઈને સમાંતર મુક્ત રીતે ગતિ કરી શકે છે. પિસ્ટનની ઊપર રહેલ નળાકારની લંબાઈ l_1 અને પિસ્ટનની નીચે રહેલ નળાકારની લંબાઈ l_2 એવી રીતે છે કે જેથી l_1 એ l_2 કરતાં વધારે હોય. નળાકારનો દરેક ભાગ સમાન તાપમાન T એ n મોલ આદર્શવાયુ ધરાવે છે. જો પિસ્ટન સ્થિર હોય તો તેનું દળ m _____ થી આપી શકાય. (R એ સાર્વત્રિક વાયુ અચળાંક અને g એ ગુરૂત્વાકર્ષણ પ્રવેગ છે.)

Options :

1. $\frac{nRT}{g} \left[\frac{1}{l_2} + \frac{1}{l_1} \right]$

2. $\frac{nRT}{g} \left[\frac{l_1 - l_2}{l_1 l_2} \right]$

3. $\frac{RT}{g} \left[\frac{2l_1 + l_2}{l_1 l_2} \right]$

4. $\frac{RT}{ng} \left[\frac{l_1 - 3l_2}{l_1 l_2} \right]$

Question Number : 11 Question Type : MCQ Option Shuffling : Yes Display Question Number : Yes Single Line Question Option : No Option Orientation : Vertical

Correct Marks : 4 Wrong Marks : 1

An ideal gas is enclosed in a cylinder at pressure of 2 atm and temperature, 300 K. The mean time between two successive collisions is 6×10^{-8} s. If the pressure is doubled and temperature is increased to 500 K, the mean time between two successive collisions will be close to :

Options :

1. 3×10^{-6} s

2. 2×10^{-7} s

3. $0.5 \times 10^{-8} \text{ s}$

4. $4 \times 10^{-8} \text{ s}$

Question Number : 11 Question Type : MCQ Option Shuffling : Yes Display Question Number : Yes Single Line Question Option : No Option Orientation : Vertical

Correct Marks : 4 Wrong Marks : 1

एक बन्द सिलेण्डर में एक आदर्श गैस 2 atm दाब, एवं 300 K तापमान पर हैं। दो क्रमागत संघट्टों के बीच औसत समय $6 \times 10^{-8} \text{ s}$ है। यदि दाब को दोगुना तथा तापमान को 500 K कर दे, तो दो क्रमागत संघट्टों के बीच औसत समय का सन्निकट मान होगा :

Options :

1. $3 \times 10^{-6} \text{ s}$

2. $2 \times 10^{-7} \text{ s}$

3. $0.5 \times 10^{-8} \text{ s}$

4. $4 \times 10^{-8} \text{ s}$

Question Number : 11 Question Type : MCQ Option Shuffling : Yes Display Question Number : Yes Single Line Question Option : No Option Orientation : Vertical

Correct Marks : 4 Wrong Marks : 1

કોઈ આદર્શ વાયુ 2 atm દબાણે અને 300 K તાપમાને એક નળાકારમાં રાખેલ છે. બે ક્રમિક અથડામણો વચ્ચેનો સરેરાશ સમય $6 \times 10^{-8} \text{ s}$ છે. હવે જો દબાણ બમણું અને તાપમાન વધારીને 500 K કરવામાં આવે તો બે ક્રમિક અથડામણો વચ્ચેનો સરેરાશ સમય લગભગ _____ થશે.

Options :

1. $3 \times 10^{-6} \text{ s}$

2. $2 \times 10^{-7} \text{ s}$

3. $0.5 \times 10^{-8} \text{ s}$

4. $4 \times 10^{-8} \text{ s}$

Question Number : 12 Question Type : MCQ Option Shuffling : Yes Display Question Number : Yes Single Line Question Option : No Option Orientation : Vertical

Correct Marks : 4 Wrong Marks : 1

A simple harmonic motion is represented by :

$$y = 5(\sin 3\pi t + \sqrt{3} \cos 3\pi t) \text{ cm}$$

The amplitude and time period of the motion are :

Options :

1. $5 \text{ cm}, \frac{3}{2} \text{ s}$

2. $5 \text{ cm}, \frac{2}{3} \text{ s}$

3. $10 \text{ cm}, \frac{3}{2} \text{ s}$

4. $10 \text{ cm}, \frac{2}{3} \text{ s}$

Question Number : 12 Question Type : MCQ Option Shuffling : Yes Display Question Number : Yes Single Line Question Option : No Option Orientation : Vertical

Correct Marks : 4 Wrong Marks : 1

एक सरल आवर्त गति को निम्न समीकरण से दिखाया जाता है :

$$y = 5(\sin 3\pi t + \sqrt{3} \cos 3\pi t) \text{ cm}$$

गति के आयाम तथा आवर्तकाल होंगे :

Options :

1. $5 \text{ cm}, \frac{3}{2} \text{ s}$

2. $5 \text{ cm}, \frac{2}{3} \text{ s}$

3. $10 \text{ cm}, \frac{3}{2} \text{ s}$

4. $10 \text{ cm}, \frac{2}{3} \text{ s}$

Question Number : 12 Question Type : MCQ Option Shuffling : Yes Display Question Number : Yes Single Line Question Option : No Option Orientation : Vertical

Correct Marks : 4 Wrong Marks : 1

કોઈ સરળ આવર્ત ગતિ

$y = 5(\sin 3\pi t + \sqrt{3} \cos 3\pi t)$ cm વડે રજૂ થાય છે.
ગતિ માટે કંપવિસ્તાર અને આવર્તકાળ _____
થશે.

Options :

1. $5 \text{ cm}, \frac{3}{2} \text{ s}$

2. $5 \text{ cm}, \frac{2}{3} \text{ s}$

3. $10 \text{ cm}, \frac{3}{2} \text{ s}$

4. $10 \text{ cm}, \frac{2}{3} \text{ s}$

Question Number : 13 Question Type : MCQ Option Shuffling : Yes Display Question Number : Yes Single Line Question Option : No Option Orientation : Vertical

Correct Marks : 4 Wrong Marks : 1

A resonance tube is old and has jagged end. It is still used in the laboratory to determine velocity of sound in air. A tuning fork of frequency 512 Hz produces first resonance when the tube is filled with water to a mark 11 cm below a reference mark, near the open end of the tube. The experiment is repeated with another fork of frequency 256 Hz which produces first resonance when water reaches a mark 27 cm below the reference mark. The velocity of sound in air, obtained in the experiment, is close to :

Options :

1. 328 ms^{-1}

2. 335 ms^{-1}

3. 322 ms^{-1}

4. 341 ms^{-1}

Question Number : 13 Question Type : MCQ Option Shuffling : Yes Display Question Number : Yes No Option Orientation : Vertical



collegedunia
India's largest Student Review Platform

Correct Marks : 4 Wrong Marks : 1

एक अनुनादी नली पुरानी है तथा उसके किनारे खराब हैं। इसको तभी भी प्रयोगशाला में, वायु में ध्वनि की चाल ज्ञात करने के लिये, उपयोग करते हैं। नली के खुले सिरे के समीप निर्देशक चिन्ह से 11 cm नीचे एक चिन्ह तक नली में जब पानी भर देते हैं, तो 512 Hz आवृत्ति का एक स्वरित्र द्विभुज प्रथम अनुनाद उत्पन्न करता है। यह प्रयोग दूसरे 256 Hz वाले स्वरित्र द्विभुज के साथ दोहराते हैं तो, प्रथम अनुनाद निर्देशक चिन्ह से 27 cm नीचे उत्पन्न हो जाता है। प्रयोग में पायी गयी ध्वनि की वायु में सन्निकट चाल होगी :

Options :

1. 328 ms^{-1}
2. 335 ms^{-1}
3. 322 ms^{-1}
4. 341 ms^{-1}

Question Number : 13 Question Type : MCQ Option Shuffling : Yes Display Question Number : Yes Single Line Question Option : No Option Orientation : Vertical

Correct Marks : 4 Wrong Marks : 1

કોઈ અનુનાદીય નળી જુની અને તેને ખવાઈને ઢાંતા પડી ગયેલ છેડો છે. હજુ પણ તે પ્રયોગશાળામાં હવામાં ધ્વનિનો વેગ માપવા વપરાય છે. જ્યારે પાણી ભરેલી નળીને તેના ખુલ્લા છેડાની નજીક દોરેલી નિશાનીથી નીચે 11 cm આગળ દોરેલ નિશાની (માર્ક) આગળ રાખતા 512 Hz ધરાવતો ધ્વનિ ચિપીયો પ્રથમ અનુનાદ ઉત્પન્ન કરે છે. જ્યારે પ્રયોગ બીજા 256 Hz આવૃત્તિનાં ધ્વનિ ચિપીયાથી પુનરાવર્તિત કરવામાં આવે છે ત્યારે પ્રથમ અનુનાદ પાણી જ્યારે આપેલ સંદર્ભ નિશાનીથી નીચે 27 cm આગળ હોય ત્યારે મળે છે. પ્રયોગમાં મળતો હવામાં ધ્વનિનો વેગ _____ ની નજીકનો હશે.

Options :

1. 328 ms^{-1}
2. 335 ms^{-1}
3. 322 ms^{-1}

4. 341 ms^{-1}

Question Number : 14 Question Type : MCQ Option Shuffling : Yes Display Question Number : Yes Single Line Question Option : No Option Orientation : Vertical

Correct Marks : 4 Wrong Marks : 1

A parallel plate capacitor with plates of area 1 m^2 each, are at a separation of 0.1 m . If the electric field between the plates is 100 N/C , the magnitude of charge on each plate is :

(Take $\epsilon_0 = 8.85 \times 10^{-12} \frac{\text{C}^2}{\text{N-m}^2}$)

Options :

1. $6.85 \times 10^{-10} \text{ C}$
2. $7.85 \times 10^{-10} \text{ C}$
3. $8.85 \times 10^{-10} \text{ C}$
4. $9.85 \times 10^{-10} \text{ C}$

Question Number : 14 Question Type : MCQ Option Shuffling : Yes Display Question Number : Yes Single Line Question Option : No Option Orientation : Vertical

Correct Marks : 4 Wrong Marks : 1

एक समान्तर प्लेट संधारित्र की प्रत्येक प्लेट का क्षेत्रफल 1 m^2 तथा प्लेटों के बीच की दूरी 0.1 m है। यदि प्लेटों के बीच विद्युत क्षेत्र 100 N/C हो तो, संधारित्र की प्रत्येक प्लेट पर आवेश का परिमाण है,

($\epsilon_0 = 8.85 \times 10^{-12} \frac{\text{C}^2}{\text{N-m}^2}$ लीजिये)

Options :

1. $6.85 \times 10^{-10} \text{ C}$
2. $7.85 \times 10^{-10} \text{ C}$
3. $8.85 \times 10^{-10} \text{ C}$
4. $9.85 \times 10^{-10} \text{ C}$

Question Number : 14 Question Type : MCQ Option Shuffling : Yes Display Question Number : Ye No Option Orientation : Vertical

Correct Marks : 4 Wrong Marks : 1

કોઈ સમાંતર પ્લેટ કેપેસિટરની દરેક પ્લેટનું ક્ષેત્રફળ 1 m^2 અને તેમની વચ્ચેનું અંતર 0.1 m છે. જો બે પ્લેટો વચ્ચેનું વિદ્યુત ક્ષેત્ર 100 N/C હોય તો દરેક પ્લેટ પરના વિદ્યુતભારનું મૂલ્ય :

$$(\epsilon_0 = 8.85 \times 10^{-12} \frac{\text{C}^2}{\text{N-m}^2} \text{ લો.})$$

Options :

1. $6.85 \times 10^{-10} \text{ C}$
2. $7.85 \times 10^{-10} \text{ C}$
3. $8.85 \times 10^{-10} \text{ C}$
4. $9.85 \times 10^{-10} \text{ C}$

Question Number : 15 Question Type : MCQ Option Shuffling : Yes Display Question Number : Yes Single Line Question Option : No Option Orientation : Vertical

Correct Marks : 4 Wrong Marks : 1

In the circuit shown, find C if the effective capacitance of the whole circuit is to be $0.5 \mu\text{F}$. All values in the circuit are in μF .

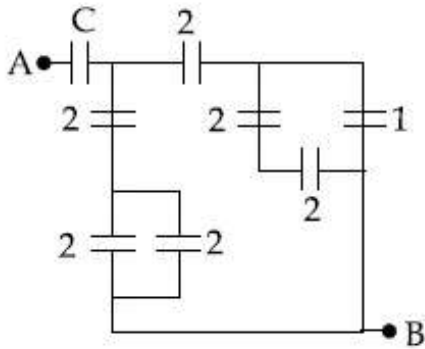

Options :

1. $\frac{7}{10} \mu\text{F}$
2. $4 \mu\text{F}$
3. $\frac{7}{11} \mu\text{F}$
4. $\frac{6}{5} \mu\text{F}$

Question Number : 15 Question Type : MCQ Option Shuffling : Yes Display Question Number : Yes Single Line Question Option : No Option Orientation : Vertical

Correct Marks : 4 Wrong Marks : 1

दिखाये गये परिपथ में, यदि पूरे परिपथ की प्रभावी धारिता $0.5 \mu\text{F}$ है तो C का मान क्या होगा? परिपथ में सभी धारिताएं μF में हैं।

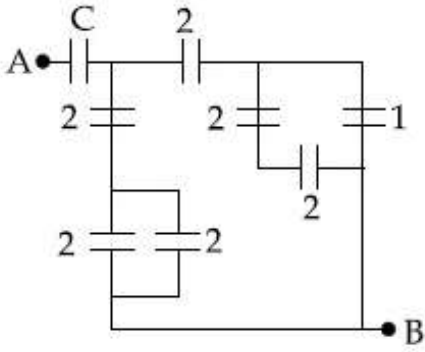

Options :

1. $\frac{7}{10} \mu\text{F}$
2. $4 \mu\text{F}$
3. $\frac{7}{11} \mu\text{F}$
4. $\frac{6}{5} \mu\text{F}$

Question Number : 15 Question Type : MCQ Option Shuffling : Yes Display Question Number : Yes Single Line Question Option : No Option Orientation : Vertical

Correct Marks : 4 Wrong Marks : 1

दशांशवेल परिपथमां, जे आभाय परिपथनी असरकारक संघारकता (कपेसिटेन्स) $0.5 \mu\text{F}$ छेय तो C शोधो. परिपथमां दशांशवेल तमाम मूल्य μF मां छे.

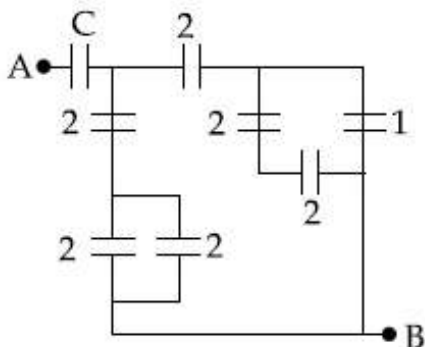

Options :

1. $\frac{7}{10} \mu\text{F}$

2. $4 \mu\text{F}$

3. $\frac{7}{11} \mu\text{F}$

4. $\frac{6}{5} \mu\text{F}$

Question Number : 16 Question Type : MCQ Option Shuffling : Yes Display Question Number : Yes Single Line Question Option : No Option Orientation : Vertical

Correct Marks : 4 Wrong Marks : 1

In the given circuit diagram, the currents, $I_1 = -0.3 \text{ A}$, $I_4 = 0.8 \text{ A}$ and $I_5 = 0.4 \text{ A}$, are flowing as shown. The currents I_2 , I_3 and I_6 , respectively, are :

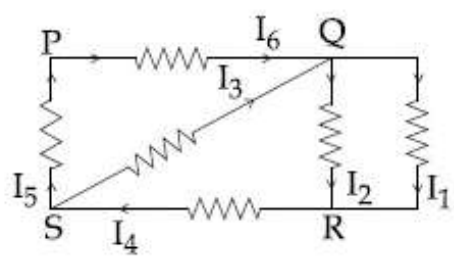

Options :

1. $1.1 \text{ A}, -0.4 \text{ A}, 0.4 \text{ A}$

2. $-0.4 \text{ A}, 0.4 \text{ A}, 1.1 \text{ A}$

3. $1.1 \text{ A}, 0.4 \text{ A}, 0.4 \text{ A}$

4. $0.4 \text{ A}, 1.1 \text{ A}, 0.4 \text{ A}$

Question Number : 16 Question Type : MCQ Option Shuffling : Yes Display Question Number : Yes Single Line Question Option : No Option Orientation : Vertical

Correct Marks : 4 Wrong Marks : 1

दिखाये गये परिपथ में धारायें $I_1 = -0.3 \text{ A}$, $I_4 = 0.8 \text{ A}$ और $I_5 = 0.4 \text{ A}$ प्रवाहित हो रही हैं। धाराओं, I_2 , I_3 तथा I_6 के मान क्रमशः होंगे :

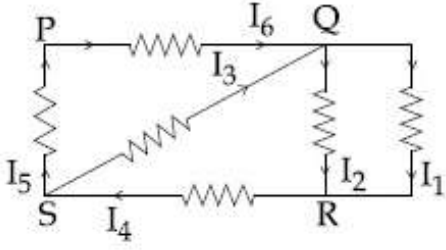

Options :

1. 1.1 A , -0.4 A , 0.4 A
2. -0.4 A , 0.4 A , 1.1 A
3. 1.1 A , 0.4 A , 0.4 A
4. 0.4 A , 1.1 A , 0.4 A

Question Number : 16 Question Type : MCQ Option Shuffling : Yes Display Question Number : Yes Single Line Question Option : No Option Orientation : Vertical

Correct Marks : 4 Wrong Marks : 1

આપેલ પરિપથમાં દર્શાવ્યા મુજબ પ્રવાહો $I_1 = -0.3 \text{ A}$, $I_4 = 0.8 \text{ A}$ અને $I_5 = 0.4 \text{ A}$ વહે છે. પ્રવાહો I_2 , I_3 અને I_6 અનુક્રમે _____ થશે.

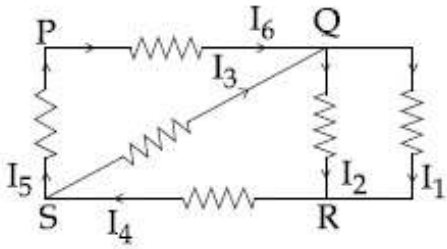

Options :

1. 1.1 A , -0.4 A , 0.4 A
2. -0.4 A , 0.4 A , 1.1 A
3. 1.1 A , 0.4 A , 0.4 A
4. 0.4 A , 1.1 A , 0.4 A

Question Number : 17 Question Type : MCQ Option Shuffling : Yes Display Question Number : Yes Single Line Question Option : No Option Orientation : Vertical

Correct Marks : 4 Wrong Marks : 1

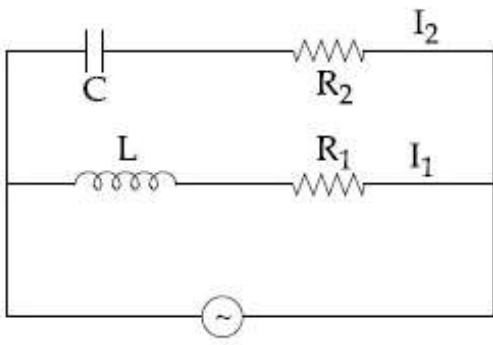

In the above circuit, $C = \frac{\sqrt{3}}{2} \mu\text{F}$, $R_2 = 20 \Omega$,

$L = \frac{\sqrt{3}}{10} \text{H}$ and $R_1 = 10 \Omega$. Current in

L- R_1 path is I_1 and in C- R_2 path it is I_2 . The voltage of A.C source is given by,

$V = 200\sqrt{2}\sin(100t)$ volts. The phase difference between I_1 and I_2 is :

Note: For this question, discrepancy is found in question/answer. Full Marks is being awarded to all candidates.

Options :

1. 0°
2. 60°
3. 90°
4. 30°

Question Number : 17 Question Type : MCQ Option Shuffling : Yes Display Question Number : Yes Single Line Question Option : No Option Orientation : Vertical

Correct Marks : 4 Wrong Marks : 1

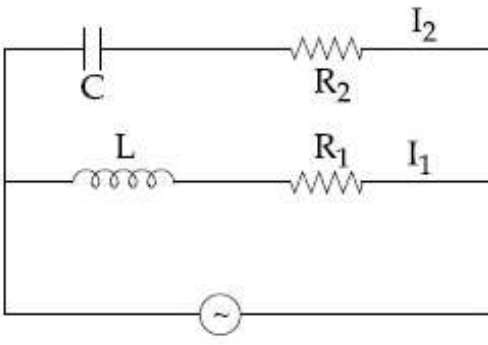

दिखाये गये परिपथ में $C = \frac{\sqrt{3}}{2} \mu\text{F}$, $R_2 = 20 \Omega$,

$L = \frac{\sqrt{3}}{10} \text{ H}$ तथा $R_1 = 10 \Omega$ है। L - R_1 पथ में धारा

I_1 , और C - R_2 पथ में धारा I_2 है। AC स्रोत की वोल्टता,

$V = 200\sqrt{2}\sin(100t)$ वोल्ट सूत्र द्वारा दी गयी है।

I_1 तथा I_2 के बीच कलान्तर है :

Note: For this question, discrepancy is found in question/answer. Full Marks is being awarded to all candidates.

Options :

1. 0°
2. 60°
3. 90°
4. 30°

Question Number : 17 Question Type : MCQ Option Shuffling : Yes Display Question Number : Yes Single Line Question Option : No Option Orientation : Vertical

Correct Marks : 4 Wrong Marks : 1

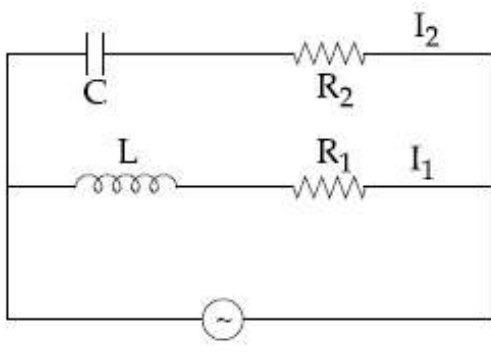

ઉપરોક્ત પરિપથમાં $C = \frac{\sqrt{3}}{2} \mu\text{F}$, $R_2 = 20 \Omega$,

$L = \frac{\sqrt{3}}{10} \text{H}$ અને $R_1 = 10 \Omega$ છે. L - R_1 માં પ્રવાહ

I_1 અને C - R_2 માં તે I_2 છે. AC વોલ્ટેજ ઉદ્દગમ

$V = 200\sqrt{2}\sin(100t)$ વોલ્ટથી આપવામાં આવે છે.

I_1 અને I_2 વચ્ચેનો કળા તફાવત :

Note: For this question, discrepancy is found in question/answer. Full Marks is being awarded to all candidates.

Options :

1. 0°
2. 60°
3. 90°
4. 30°

Question Number : 18 Question Type : MCQ Option Shuffling : Yes Display Question Number : Yes Single Line Question Option : No Option Orientation : Vertical

Correct Marks : 4 Wrong Marks : 1

A galvanometer, whose resistance is 50 ohm, has 25 divisions in it. When a current of $4 \times 10^{-4} \text{A}$ passes through it, its needle (pointer) deflects by one division. To use this galvanometer as a voltmeter of range 2.5 V, it should be connected to a resistance of :

Options :

1. 6250 ohm
2. 6200 ohm
3. 250 ohm
4. 200 ohm

Question Number : 18 Question Type : MCQ Option Shuffling : Yes Display Question Number : Yes Single Line Question Option : No Option Orientation : Vertical

Correct Marks : 4 Wrong Marks : 1

50 Ω પ્રતિરોધ વાલે એક ગૈલ્વેનોમીટર મેં 25 ભાગ હૈં । જબ ઇસમેં 4×10^{-4} A કી ધારા પ્રવાહિત કરતે હૈં તો ઇસકી સુઈ દ્વારા 1 ભાગ કા વિક્ષેપ હોતા હૈં । ઇસ ગૈલ્વેનોમીટર કો 2.5 V પરાસ વાલે વોલ્ટમીટર કે રૂપ મેં ઉપયોગ કરને કે લિયે, ઇસકે સાથ કૌન-સા પ્રતિરોધ જોડના પડેગા ?

Options :

1. 6250 ohm
2. 6200 ohm
3. 250 ohm
4. 200 ohm

Question Number : 18 Question Type : MCQ Option Shuffling : Yes Display Question Number : Yes Single Line Question Option : No Option Orientation : Vertical

Correct Marks : 4 Wrong Marks : 1

કોઈ અસિત ગુંચળું ધરાવતા ગેલ્વેનોમીટરનો અવરોધ 50 Ω અને તેના પર 25 કાપા છે. જ્યારે તેમાંથી 4×10^{-4} એમ્પિયર પ્રવાહ પસાર થાય ત્યારે તેની સોય (દર્શક) એક કાપા જેટલું આવર્તન અનુભવે છે. આ ગેલ્વેનોમીટરને 2.5Vના વોલ્ટમીટર તરીકે વાપરવું હોય તો તે _____ અવરોધ સાથે જોડવું પડશે.

Options :

1. 6250 ઓહ્મ
2. 6200 ઓહ્મ
3. 250 ઓહ્મ
4. 200 ઓહ્મ

Question Number : 19 Question Type : MCQ Option Shuffling : Yes Display Question Number : Yes Single Line Question Option : No Option Orientation : Vertical

Correct Marks : 4 Wrong Marks : 1

A paramagnetic material has 10^{28} atoms/ m^3 . Its magnetic susceptibility at temperature 350 K is 2.8×10^{-4} . Its susceptibility at 300 K is :

Options :

1. 3.726×10^{-4}
2. 3.267×10^{-4}
3. 2.672×10^{-4}
4. 3.672×10^{-4}

Question Number : 19 Question Type : MCQ Option Shuffling : Yes Display Question Number : Yes Single Line Question Option : No Option Orientation : Vertical

Correct Marks : 4 Wrong Marks : 1

एक अनुचुम्बकीय पदार्थ में 10^{28} परमाणु /मी³ हैं। पदार्थ की 350 K तापमान पर, चुम्बकीय प्रवृत्ति 2.8×10^{-4} है। 300 K पर, उसकी चुम्बकीय प्रवृत्ति होगी :

Options :

1. 3.726×10^{-4}
2. 3.267×10^{-4}
3. 2.672×10^{-4}
4. 3.672×10^{-4}

Question Number : 19 Question Type : MCQ Option Shuffling : Yes Display Question Number : Yes Single Line Question Option : No Option Orientation : Vertical

Correct Marks : 4 Wrong Marks : 1

કોઈ અનુચુંબકીય (પેરામેગ્નેટીક) પદાર્થમાં 10^{28} પરમાણુ પ્રતિ m^3 રહેલા છે. તેની 350 K તાપમાને ચુંબકીય સસેપ્ટિબિલિટી 2.8×10^{-4} છે. તેની 300 K તાપમાને સસેપ્ટિબિલિટી _____ થશે.

Options :

1. 3.726×10^{-4}
2. 3.267×10^{-4}
3. 2.672×10^{-4}

4. 3.672×10^{-4}

Question Number : 20 Question Type : MCQ Option Shuffling : Yes Display Question Number : Yes Single Line Question Option : No Option Orientation : Vertical

Correct Marks : 4 Wrong Marks : 1

A 10 m long horizontal wire extends from North East to South West. It is falling with a speed of 5.0 ms^{-1} , at right angles to the horizontal component of the earth's magnetic field, of $0.3 \times 10^{-4} \text{ Wb/m}^2$. The value of the induced emf in wire is :

Options :

1. $1.1 \times 10^{-3} \text{ V}$
2. $2.5 \times 10^{-3} \text{ V}$
3. $1.5 \times 10^{-3} \text{ V}$
4. $0.3 \times 10^{-3} \text{ V}$

Question Number : 20 Question Type : MCQ Option Shuffling : Yes Display Question Number : Yes Single Line Question Option : No Option Orientation : Vertical

Correct Marks : 4 Wrong Marks : 1

एक 10 मीटर का क्षैतिज तार, उत्तर-पूर्व से दक्षिण-पश्चिम दिशा में विस्तृत है, और 5.0 ms^{-1} की चाल से पृथ्वी के चुम्बकीय क्षेत्र के क्षैतिज घटक, $0.3 \times 10^{-4} \text{ Wb/m}^2$, के लम्बवत् गिर रहा है। तार में प्रेरित विद्युत वाहक बल का मान होगा :

Options :

1. $1.1 \times 10^{-3} \text{ V}$
2. $2.5 \times 10^{-3} \text{ V}$
3. $1.5 \times 10^{-3} \text{ V}$
4. $0.3 \times 10^{-3} \text{ V}$

Question Number : 20 Question Type : MCQ Option Shuffling : Yes Display Question Number : Yes Single Line Question Option : No Option Orientation : Vertical

Correct Marks : 4 Wrong Marks : 1

કોઈ 10 m લાંબો સમક્ષિતિજ તાર કે જે ઉત્તર-પૂર્વથી દક્ષિણ-પશ્ચિમ દિશામાં ખેંચાયેલો હોય અને પૃથ્વીના $0.3 \times 10^{-4} \text{ Wb/m}^2$ ના ચુંબકીય ક્ષેત્રના સમક્ષિતિજ ઘટને કાટકોણે 5.0 ms^{-1} ની ઝડપથી પતન કરે છે. પ્રેરિત emf નું તત્કાલિક મૂલ્ય હશે :

Options :

1. $1.1 \times 10^{-3} \text{ V}$
2. $2.5 \times 10^{-3} \text{ V}$
3. $1.5 \times 10^{-3} \text{ V}$
4. $0.3 \times 10^{-3} \text{ V}$

Question Number : 21 Question Type : MCQ Option Shuffling : Yes Display Question Number : Yes Single Line Question Option : No Option Orientation : Vertical

Correct Marks : 4 Wrong Marks : 1

The mean intensity of radiation on the surface of the Sun is about 10^8 W/m^2 . The rms value of the corresponding magnetic field is closest to :

Options :

1. 10^{-4} T
2. 10^{-2} T
3. 1 T
4. 10^2 T

Question Number : 21 Question Type : MCQ Option Shuffling : Yes Display Question Number : Yes Single Line Question Option : No Option Orientation : Vertical

Correct Marks : 4 Wrong Marks : 1

સૂર્યની સપાટી ઉપર વિકિરણની સરેરાશ તીવ્રતા લગભગ 10^8 W/m^2 છે. તેને આનુષંગિક ચુંબકીય ક્ષેત્રનું rms મૂલ્ય _____ ની નજીકનું હશે.

Options :

1. 10^{-4} T
2. 10^{-2} T
3. 1 T

4. 10^2 T

Question Number : 21 Question Type : MCQ Option Shuffling : Yes Display Question Number : Yes Single Line Question Option : No Option Orientation : Vertical

Correct Marks : 4 Wrong Marks : 1

सूर्य की सतह पर विकिरण की औसत तीव्रता लगभग 10^8 W/m² है। तो संगत चुम्बकीय क्षेत्र का निकटतम वर्ग-माध्य-मूल मान होगा :

Options :

1. 10^{-4} T

2. 10^{-2} T

3. 1 T

4. 10^2 T

Question Number : 22 Question Type : MCQ Option Shuffling : Yes Display Question Number : Yes Single Line Question Option : No Option Orientation : Vertical

Correct Marks : 4 Wrong Marks : 1

A plano-convex lens (focal length f_2 , refractive index μ_2 , radius of curvature R) fits exactly into a plano-concave lens (focal length f_1 , refractive index μ_1 , radius of curvature R). Their plane surfaces are parallel to each other. Then, the focal length of the combination will be :

Options :

1. $f_1 + f_2$

2. $f_1 - f_2$

3. $\frac{2f_1 f_2}{f_1 + f_2}$

4. $\frac{R}{\mu_2 - \mu_1}$

Question Number : 22 Question Type : MCQ Option Shuffling : Yes Display Question Number : Yes Single Line Question Option : No Option Orientation : Vertical

Correct Marks : 4 Wrong Marks : 1

एक समतल-उत्तल लेंस (फोकस दूरी f_2 , अपवर्तनांक μ_2 , वक्रता त्रिज्या R) एक समतल-अवतल लेंस (फोकस दूरी f_1 , अपवर्तनांक μ_1 , वक्रता त्रिज्या R) में ठीक बैठ जाता है। उनके समतल पृष्ठ एक दूसरे के समान्तर हैं। इस संयोजन की फोकस दूरी होगी :

Options :

1. $f_1 + f_2$

2. $f_1 - f_2$

3. $\frac{2f_1 f_2}{f_1 + f_2}$

4. $\frac{R}{\mu_2 - \mu_1}$

Question Number : 22 Question Type : MCQ Option Shuffling : Yes Display Question Number : Yes Single Line Question Option : No Option Orientation : Vertical

Correct Marks : 4 Wrong Marks : 1

કોઈ સમતલ-બહિર્ગોળ લેન્સ (કેન્દ્રલંબાઈ f_2 , વક્રીભવનાંક μ_2 અને વક્રતાત્રિજ્યા R) એ કોઈ સમતલ-અંતર્ગોળ લેન્સ (કેન્દ્ર લંબાઈ f_1 , વક્રીભવનાંક μ_1 અને વક્રતાત્રિજ્યા R) માં બરાબર બંધ બેસે છે. તેમની સમતલ સપાટીઓ એક બીજાને સમાંતર રહે છે. તો આ સંયોજનની કેન્દ્ર લંબાઈ _____ થશે.

Options :

1. $f_1 + f_2$

2. $f_1 - f_2$

3. $\frac{2f_1 f_2}{f_1 + f_2}$

4. $\frac{R}{\mu_2 - \mu_1}$

Question Number : 23 Question Type : MCQ Option Shuffling : Yes Display Question Number : Yes Single Line Question Option : No Option Orientation : Vertical

Correct Marks : 4 Wrong Marks : 1

Formation of real image using a biconvex lens is shown below :

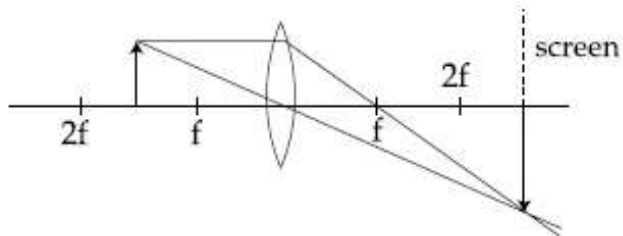

If the whole set up is immersed in water without disturbing the object and the screen positions, what will one observe on the screen ?

Options :

1. No change
2. Magnified image
3. Image disappears
4. Erect real image

Question Number : 23 Question Type : MCQ Option Shuffling : Yes Display Question Number : Yes Single Line Question Option : No Option Orientation : Vertical

Correct Marks : 4 Wrong Marks : 1

एक उभयोत्तल लेंस से एक वास्तविक प्रतिबिम्ब के बनने का चित्र में दर्शाया गया है :

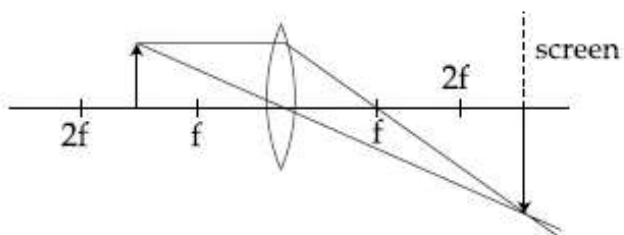

वस्तु तथा पर्दे की स्थिति को बिना विचलित किये इस संपूर्ण संयोजन को यदि पानी में डुबा दिया जाये तो, पर्दे पर क्या दिखेगा ?

Options :

1. कोई बदलाव नहीं
2. आवर्धित प्रतिबिम्ब
3. प्रतिबिम्ब लुप्त हो जायेगा
4. ऊर्ध्व (erect) वास्तविक प्रतिबिम्ब

Question Number : 23 Question Type : MCQ Option Shuffling : Yes Display Question Number : Yes Single Line Question Option : No Option Orientation : Vertical

Correct Marks : 4 Wrong Marks : 1

કોઈ દ્વિ-બહિર્ગોળ લેન્સ વડે રચાતા વાસ્તવિક પ્રતિબિંબની રચના નીચે દર્શાવેલ છે.

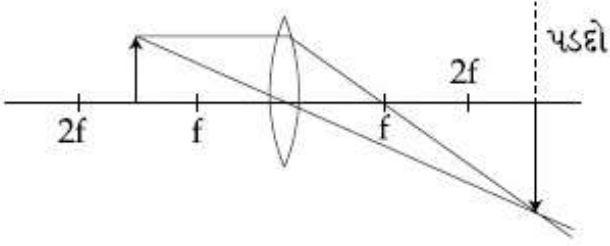

જો આ આખીય ગોઠવણીને વસ્તુ અને પડદાના સ્થાનને ખલેલ પહોંચાડ્યા (બદલ્યા) વગર પાણીમાં ડૂબાડવામાં આવે તો પડદા પર આપણને શું દેખાશે?

Options :

1. કોઈ ફેરફાર નહીં
2. વિસ્તૃત (મોટું) પ્રતિબિંબ
3. પ્રતિબિંબ દેખાશે નહીં
4. સીધું વાસ્તવિક પ્રતિબિંબ

Question Number : 24 Question Type : MCQ Option Shuffling : Yes Display Question Number : Yes Single Line Question Option : No Option Orientation : Vertical

Correct Marks : 4 Wrong Marks : 1

જબ કોઈ પ્રકાશ સંવેદી સતહ ν આવૃત્તિ કે એક વર્ણીય પ્રકાશ દ્વારા પ્રકાશિત કી જાતી હૈ તો પ્રકાશ વૈદ્યુત ધારા કા નિરોધી વિભવ $-V_0/2$ હોતા હૈ। જબ વહી સતહ $\nu/2$ આવૃત્તિ કે એકવર્ણી પ્રકાશ દ્વારા પ્રકાશિત કી જાતી હૈ તો નિરોધી વિભવ $-V_0$ પાયા જાતા હૈ। પ્રકાશ-વૈદ્યુત ઉત્સર્જન કી દેહલી આવૃત્તિ હોગી :

Options :

1. 2ν
2. $\frac{5\nu}{3}$
3. $\frac{4}{3}\nu$

4. $\frac{3\nu}{2}$

Question Number : 24 Question Type : MCQ Option Shuffling : Yes Display Question Number : Yes Single Line Question Option : No Option Orientation : Vertical

Correct Marks : 4 Wrong Marks : 1

જ્યારે કોઈ ફોટો સંવેદી સપાટીને ν જેટલી આવૃત્તિ ધરાવતા એકરંગી પ્રકાશથી પ્રકાશિત કરવામાં આવે છે. ત્યારે ફોટો-પ્રવાહ માટેનું સ્ટોપિંગ પોટેન્શિયલ (સ્થિતિમાન) $-V_0/2$ મળે છે. જ્યારે સપાટીને $\nu/2$ જેટલી આવૃત્તિ ધરાવતા એકરંગી પ્રકાશથી પ્રકાશિત કરવામાં આવે છે ત્યારે સ્ટોપિંગ પોટેન્શિયલ $-V_0$ મળે છે. આ ફોટો ઇલેક્ટ્રિક ઉત્સર્જન માટેની થ્રેશોલ્ડ આવૃત્તિ _____ હશે.

Options :

1. 2ν

2. $\frac{5\nu}{3}$

3. $\frac{4}{3}\nu$

4. $\frac{3\nu}{2}$

Question Number : 24 Question Type : MCQ Option Shuffling : Yes Display Question Number : Yes Single Line Question Option : No Option Orientation : Vertical

Correct Marks : 4 Wrong Marks : 1

When a certain photosensitive surface is illuminated with monochromatic light of frequency ν , the stopping potential for the photo current is $-V_0/2$. When the surface is illuminated by monochromatic light of frequency $\nu/2$, the stopping potential is $-V_0$. The threshold frequency for photoelectric emission is :

Options :

1. 2ν

2. $\frac{5\nu}{3}$

3. $\frac{4}{3} \nu$

4. $\frac{3\nu}{2}$

Question Number : 25 Question Type : MCQ Option Shuffling : Yes Display Question Number : Yes Single Line Question Option : No Option Orientation : Vertical

Correct Marks : 4 Wrong Marks : 1

In a Frank-Hertz experiment, an electron of energy 5.6 eV passes through mercury vapour and emerges with an energy 0.7 eV. The minimum wavelength of photons emitted by mercury atoms is close to :

Options :

1. 220 nm
2. 2020 nm
3. 1700 nm
4. 250 nm

Question Number : 25 Question Type : MCQ Option Shuffling : Yes Display Question Number : Yes Single Line Question Option : No Option Orientation : Vertical

Correct Marks : 4 Wrong Marks : 1

एक फ्रैंक-हर्ट्ज प्रयोग के दौरान, 5.6 eV ऊर्जा का एक इलेक्ट्रॉन पारे के वाष्प से गुजर कर 0.7 eV की ऊर्जा के साथ बाहर निकलता है। पारे के परमाणु द्वारा उत्सर्जित फोटॉन की न्यूनतम तरंगदैर्घ्य का सन्निकट मान होगा :

Options :

1. 220 nm
2. 2020 nm
3. 1700 nm
4. 250 nm

Question Number : 25 Question Type : MCQ Option Shuffling : Yes Display Question Number : Yes Single Line Question Option : No Option Orientation : Vertical

Correct Marks : 4 Wrong Marks : 1

ફેન્ક-હટ્ઝના પ્રયોગમાં, 5.6 eV ઊર્જા ધરાવતો કોઈ ઇલેક્ટ્રોન પારાની બાષ્પમાંથી પસાર થાય છે અને 0.7 eV ઊર્જા સાથે નિર્ગમન પામે છે. ત્યારબાદ પારો એક પ્રોટોનનું ઉત્સર્જન કરે છે. ઉત્સર્જતા પ્રોટોનની લઘુત્તમ તરંગલંબાઈ _____ ની નજીકની હશે.

Options :

1. 220 nm
2. 2020 nm
3. 1700 nm
4. 250 nm

Question Number : 26 Question Type : MCQ Option Shuffling : Yes Display Question Number : Yes Single Line Question Option : No Option Orientation : Vertical

Correct Marks : 4 Wrong Marks : 1

In a radioactive decay chain, the initial nucleus is ${}_{90}^{232}\text{Th}$. At the end there are 6 α -particles and 4 β -particles which are emitted. If the end nucleus is ${}_{Z}^AX$, A and Z are given by :

Options :

1. A = 202 ; Z = 80
2. A = 208 ; Z = 82
3. A = 208 ; Z = 80
4. A = 200 ; Z = 81

Question Number : 26 Question Type : MCQ Option Shuffling : Yes Display Question Number : Yes Single Line Question Option : No Option Orientation : Vertical

Correct Marks : 4 Wrong Marks : 1

કિસી એક રેડિયો-એક્ટિવ ક્ષય શ્રેણીમાં આરંભિક નાભિક ${}_{90}^{232}\text{Th}$ છે. અંતમાં કુલ 6 α -કણ અને 4 β -કણ ઉત્સર્જિત થયા છે. અંત નાભિક ${}_{Z}^AX$ છે તો, A અને Z ના મૂલ્યો :

Options :

1. $A = 202 ; Z = 80$
2. $A = 208 ; Z = 82$
3. $A = 208 ; Z = 80$
4. $A = 200 ; Z = 81$

Question Number : 26 Question Type : MCQ Option Shuffling : Yes Display Question Number : Yes Single Line Question Option : No Option Orientation : Vertical

Correct Marks : 4 Wrong Marks : 1

રેડિયો-એક્ટિવ શ્રુંખલા ક્ષય પ્રક્રિયામાં, પ્રારંભિક ન્યુક્લિયસ ${}_{90}^{232}\text{Th}$ છે. અંતે, 6 α -કણો અને 4 β -કણો ઉત્સર્જન પામે છે. અંત ન્યુક્લિયસ $\frac{A}{Z}\text{X}$ છે, A અને Z _____ થી આપી શકાય.

Options :

1. $A = 202 ; Z = 80$
2. $A = 208 ; Z = 82$
3. $A = 208 ; Z = 80$
4. $A = 200 ; Z = 81$

Question Number : 27 Question Type : MCQ Option Shuffling : Yes Display Question Number : Yes Single Line Question Option : No Option Orientation : Vertical

Correct Marks : 4 Wrong Marks : 1

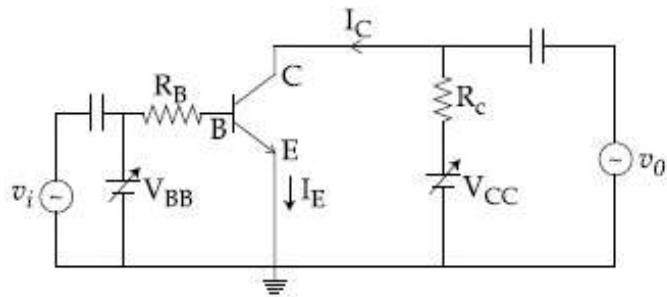

In the figure, given that V_{BB} supply can vary from 0 to 5.0 V, $V_{CC} = 5$ V, $\beta_{dc} = 200$, $R_B = 100$ k Ω , $R_C = 1$ k Ω and $V_{BE} = 1.0$ V, The minimum base current and the input voltage at which the transistor will go to saturation, will be, respectively :

Options :

1. 25 μA and 3.5 V

2. $20 \mu\text{A}$ and 2.8 V
3. $25 \mu\text{A}$ and 2.8 V
4. $20 \mu\text{A}$ and 3.5 V

Question Number : 27 Question Type : MCQ Option Shuffling : Yes Display Question Number : Yes Single Line Question Option : No Option Orientation : Vertical

Correct Marks : 4 Wrong Marks : 1

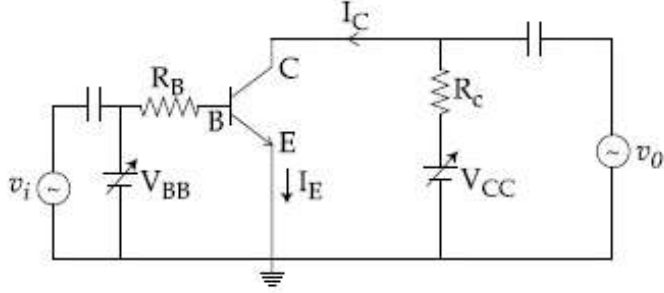

दिखाये गये चित्र में V_{BB} स्रोत 0 से 5.0 V तक बदल सकता है, $V_{CC} = 5 \text{ V}$, $\beta_{dc} = 200$, $R_B = 100 \text{ k}\Omega$, $R_C = 1 \text{ k}\Omega$ और $V_{BE} = 1.0 \text{ V}$ हैं। न्यूनतम आधार धारा तथा निवेशी सिग्नल, जिस पर ट्रांजिस्टर संतृप्ति अवस्था में पहुँच जाये, क्रमशः होंगे :

Options :

1. $25 \mu\text{A}$ और 3.5 V
2. $20 \mu\text{A}$ और 2.8 V
3. $25 \mu\text{A}$ और 2.8 V
4. $20 \mu\text{A}$ और 3.5 V

Question Number : 27 Question Type : MCQ Option Shuffling : Yes Display Question Number : Yes Single Line Question Option : No Option Orientation : Vertical

Correct Marks : 4 Wrong Marks : 1

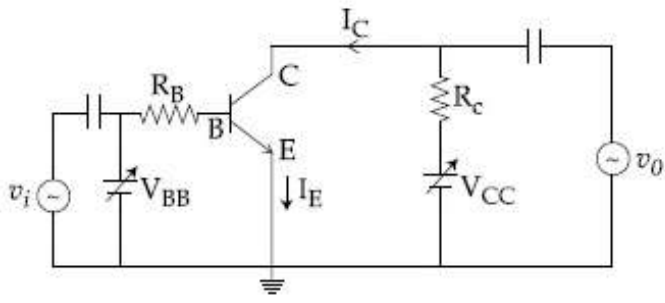

ઊપર આપેલ આકૃતિમાં V_{BB} ઉદ્ગમ 0 થી 5.0 V સુધી બદલાય છે, $V_{CC} = 5$ V, $\beta_{dc} = 200$ અને $R_B = 100$ k Ω , $R_C = 1$ k Ω અને $V_{BE} = 1.0$ V છે. ટ્રાન્ઝિસ્ટર સંતૃપ્ત સ્થિતિમાં પહોંચે તે માટે લઘુત્તમ બેઇઝ પ્રવાહ અને ટ્રાન્ઝિસ્ટર સંતૃપ્ત સ્થિતિમાં પહોંચે તે માટેનો ઇનપૂટ (આદાન) વોલ્ટેજ, અનુક્રમે _____ થશે.

Options :

1. 25 μ A અને 3.5 V
2. 20 μ A અને 2.8 V
3. 25 μ A અને 2.8 V
4. 20 μ A અને 3.5 V

Question Number : 28 Question Type : MCQ Option Shuffling : Yes Display Question Number : Yes Single Line Question Option : No Option Orientation : Vertical

Correct Marks : 4 Wrong Marks : 1

To double the covering range of a TV transmission tower, its height should be multiplied by :

Options :

1. 2
2. 4
3. $\sqrt{2}$
4. $\frac{1}{\sqrt{2}}$

Question Number : 28 Question Type : MCQ Option Shuffling : Yes Display Question Number : Yes Single Line Question Option : No Option Orientation : Vertical

Correct Marks : 4 Wrong Marks : 1

एक टी.वी. प्रसारण मीनार के विस्तार परास को दोगुना करने के लिए उसकी ऊँचाई को बदलना होगा :

Options :

1. 2 गुना
2. 4 गुना
3. $\sqrt{2}$ गुना
4. $\frac{1}{\sqrt{2}}$ गुना

Question Number : 28 Question Type : MCQ Option Shuffling : Yes Display Question Number : Yes Single Line Question Option : No Option Orientation : Vertical

Correct Marks : 4 Wrong Marks : 1

TV ट्रांसमीटर टावर माटे आवरी लेवातो विस्तार बभणो करवा तेनी उँचाईने _____ थी गुणवी पडरो.

Options :

1. 2
2. 4
3. $\sqrt{2}$
4. $\frac{1}{\sqrt{2}}$

Question Number : 29 Question Type : MCQ Option Shuffling : Yes Display Question Number : Yes Single Line Question Option : No Option Orientation : Vertical

Correct Marks : 4 Wrong Marks : 1

A load of mass M kg is suspended from a steel wire of length 2 m and radius 1.0 mm in Searle's apparatus experiment. The increase in length produced in the wire is 4.0 mm. Now the load is fully immersed in a liquid of relative density 2. The relative density of the material of load is 8.

The new value of increase in length of the steel wire is :

Options :

1. 4.0 mm

2. 3.0 mm
3. zero
4. 5.0 mm

Question Number : 29 Question Type : MCQ Option Shuffling : Yes Display Question Number : Yes Single Line Question Option : No Option Orientation : Vertical

Correct Marks : 4 Wrong Marks : 1

સર્લ ઉપકરણ કે એક પ્રયોગ મેં, M kg દ્રવ્યમાન કે એક ભાર કો, 2 m લમ્બાઈ તથા 1.0 mm ત્રિજ્યા કે એક સ્ટીલ કે તાર સે લટકાતે હૈં। તાર કી લમ્બાઈ મેં 4.0 mm કી વૃદ્ધિ હોતી હૈ। અવ ભાર કો આપેક્ષિક ઘનત્વ 2 વાલે દ્રવ મેં ડુબો દેતે હૈં। ભાર કે પદાર્થ કા આપેક્ષિક ઘનત્વ 8 હૈ। તાર કી લમ્બાઈ મેં વૃદ્ધિ કા નયા માન હોગા :

Options :

1. 4.0 mm
2. 3.0 mm
3. zero
4. 5.0 mm

Question Number : 29 Question Type : MCQ Option Shuffling : Yes Display Question Number : Yes Single Line Question Option : No Option Orientation : Vertical

Correct Marks : 4 Wrong Marks : 1

સર્લના પ્રયોગમાં, M kg દળ ધરાવતા ભારને, 2 m લંબાઈ ધરાવતા અને 1.0 mm ત્રિજ્યા ધરાવતા સ્ટીલના તાર વડે લટકાવેલ છે. તારની લંબાઈમાં થતો વધારો 4.0 mm છે. હવે, ભારને સાપેક્ષ ઘનતા 2 ધરાવતા પ્રવાહીમાં ડુબાડવામાં આવે છે. ભારના દ્રવ્યની સાપેક્ષ ઘનતા 8 છે. સ્ટીલના તારની લંબાઈમાં થતી લંબાઈનો નવો વધારો _____ છે.

Options :

1. 4.0 mm
2. 3.0 mm
3. શૂન્ય

4. 5.0 mm

Question Number : 30 Question Type : MCQ Option Shuffling : Yes Display Question Number : Yes Single Line Question Option : No Option Orientation : Vertical

Correct Marks : 4 Wrong Marks : 1

The charge on a capacitor plate in a circuit, as a function of time, is shown in the figure :

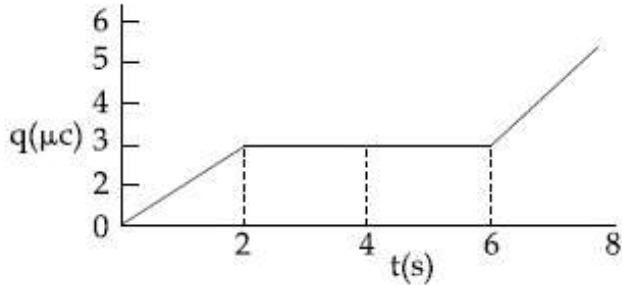

What is the value of current at $t = 4$ s ?

Options :

1. $3 \mu\text{A}$
2. $1.5 \mu\text{A}$
3. $2 \mu\text{A}$
4. zero

Question Number : 30 Question Type : MCQ Option Shuffling : Yes Display Question Number : Yes Single Line Question Option : No Option Orientation : Vertical

Correct Marks : 4 Wrong Marks : 1

एक परिपथ में संधारित्र की प्लेट पर आवेश का, समय के साथ, फलन चित्र में दिखाया गया है। $t = 4$ s पर धारा का मान क्या है?

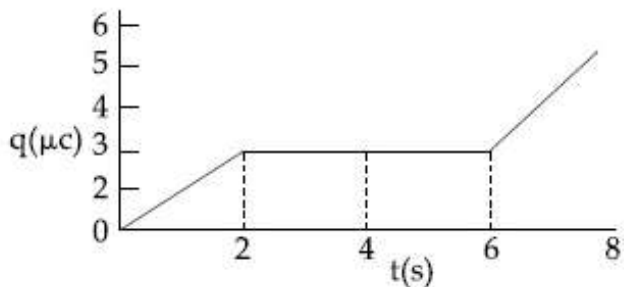

Options :

1. $3 \mu\text{A}$
2. $1.5 \mu\text{A}$

3. $2 \mu\text{A}$

4. zero

Question Number : 30 Question Type : MCQ Option Shuffling : Yes Display Question Number : Yes Single Line Question Option : No Option Orientation : Vertical

Correct Marks : 4 Wrong Marks : 1

आकृतिमां दर्शाव्या प्रमाणे विद्युतभार विद्भ्र समय आलेख परथी $t = 4 \text{ s}$ अे प्रवाहनुं मूल्य :

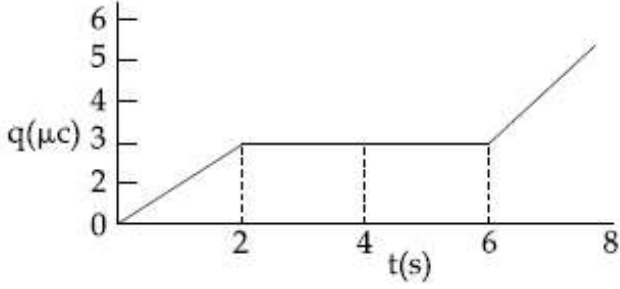

Options :

1. $3 \mu\text{A}$

2. $1.5 \mu\text{A}$

3. $2 \mu\text{A}$

4. शून्य

Section Id :

Section Number :

Section type :

Mandatory or Optional:

Number of Questions:

Number of Questions to be attempted:

Section Marks:

Display Number Panel:

Group All Questions:

Chemistry

416529155

2

Online

Mandatory

30

30

120

Yes

No

Sub-Section Number:

1

Sub-Section Id:

416529164

Question Shuffling Allowed :

Yes

Question Number : 31 Question Type : MCQ Option Shuffling : Yes Display Question Number : Yes Single Line Question Option : No Option Orientation : Vertical

Correct Marks : 4 Wrong Marks : 1

The major product of the following reaction is :

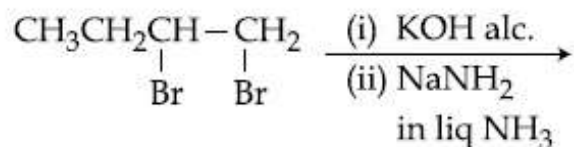

Options :

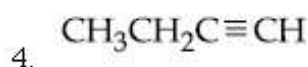
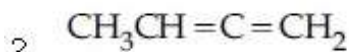
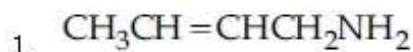

Question Number : 31 Question Type : MCQ Option Shuffling : Yes Display Question Number : Yes Single Line Question Option : No Option Orientation : Vertical

Correct Marks : 4 Wrong Marks : 1

निम्नलिखित अभिक्रिया का मुख्य उत्पाद है :

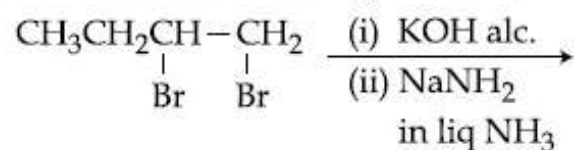

Options :

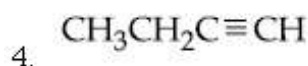
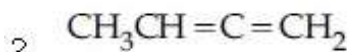
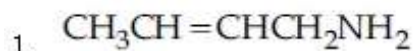

Question Number : 31 Question Type : MCQ Option Shuffling : Yes Display Question Number : Yes Single Line Question Option : No Option Orientation : Vertical

Correct Marks : 4 Wrong Marks : 1

नीचे आपेसी प्रक्रियांनी मुख्य नीपण शोधो ?

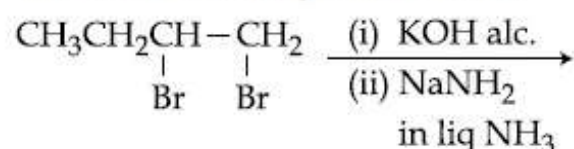

Options :

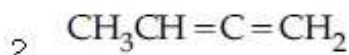
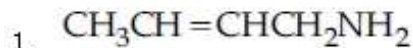

Question Number : 32 Question Type : MCQ Option Shuffling : Yes Display Question Number : Yes Single Line Question Option : No Option Orientation : Vertical

Correct Marks : 4 Wrong Marks : 1

The two monomers for the synthesis of Nylon 6, 6 are :

Options :

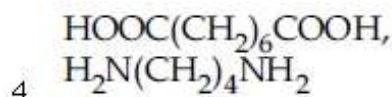
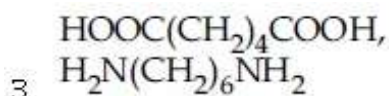
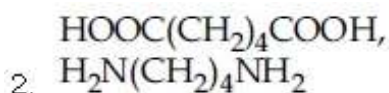
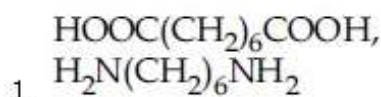

Question Number : 32 Question Type : MCQ Option Shuffling : Yes Display Question Number : Yes Single Line Question Option : No Option Orientation : Vertical

Correct Marks : 4 Wrong Marks : 1

नाइलॉन 6, 6 के संश्लेषण के लिए दो एकलक हैं :

Options :

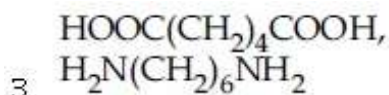
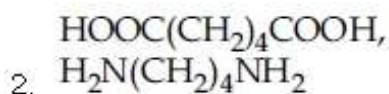
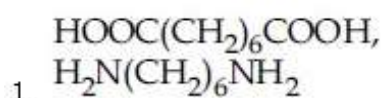

Question Number : 32 Question Type : MCQ Option Shuffling : Yes Display Question Number : Yes Single Line Question Option : No Option Orientation : Vertical

Correct Marks : 4 Wrong Marks : 1

नाथलोन 6, 6 ना संश्लेषण माटे वपराता वे मोनोमर शोधो?

Options :

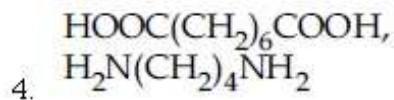
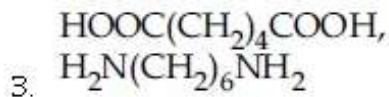
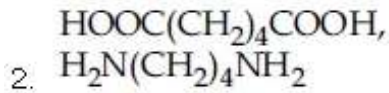
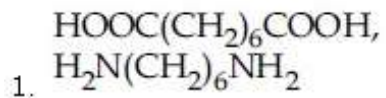

Question Number : 33 Question Type : MCQ Option Shuffling : Yes Display Question Number : Yes Single Line Question Option : No Option Orientation : Vertical

Correct Marks : 4 Wrong Marks : 1

The major product of the following reaction is :

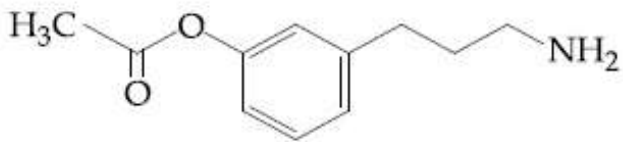

(i) NaNO_2/H^+

(ii) CrO_3/H^+

(iii) H_2SO_4 (conc.), Δ

Options :

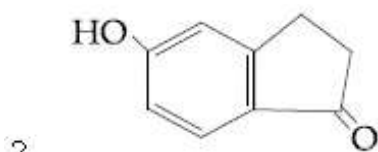
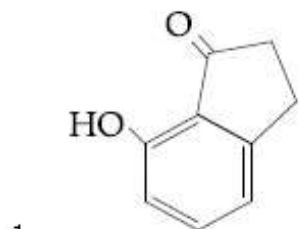

3.

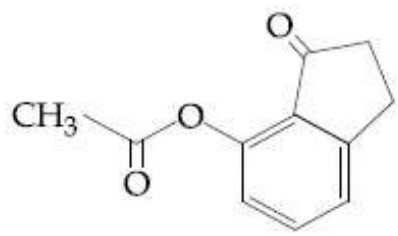

4.

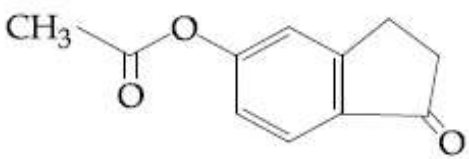

Question Number : 33 Question Type : MCQ Option Shuffling : Yes Display Question Number : Yes Single Line Question Option : No Option Orientation : Vertical

Correct Marks : 4 Wrong Marks : 1

निम्नलिखित अभिक्रिया का मुख्य उत्पाद है :

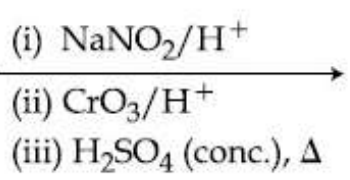
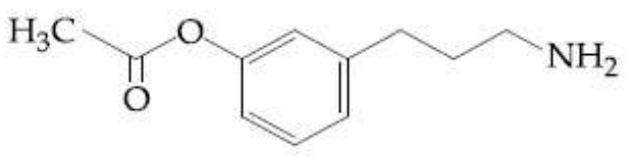

Options :

1.

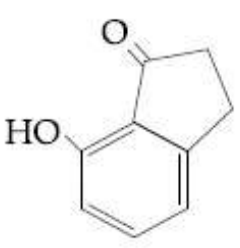

2.

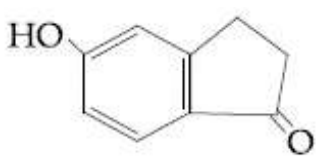

3.

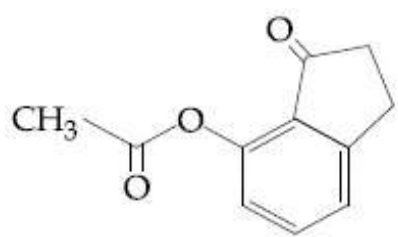

4.

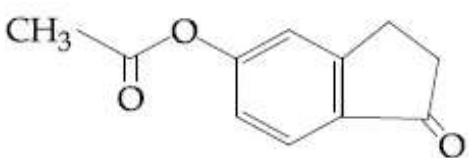

Question Number : 33 Question Type : MCQ Option Shuffling : Yes Display Question Number : Yes Single Line Question Option : No Option Orientation : Vertical

Correct Marks : 4 Wrong Marks : 1

નીચે આપેલ પ્રક્રિયાની મુખ્ય નીપજ શોધો ?

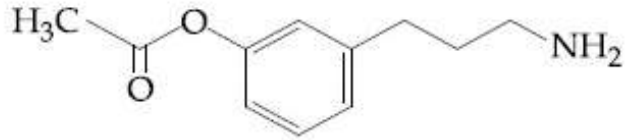

(i) NaNO_2/H^+

(ii) CrO_3/H^+

(iii) H_2SO_4 (conc.), Δ

Options :

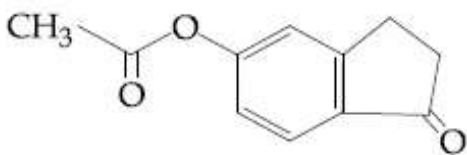
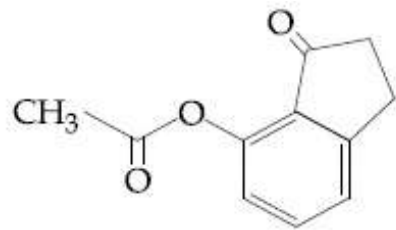
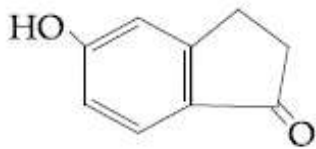
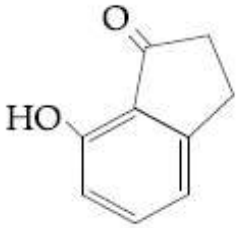

Question Number : 34 Question Type : MCQ Option Shuffling : Yes Display Question Number : Yes Single Line Question Option : No Option Orientation : Vertical

Correct Marks : 4 Wrong Marks : 1

The correct structure of histidine in a strongly acidic solution ($\text{pH} = 2$) is :

Options :

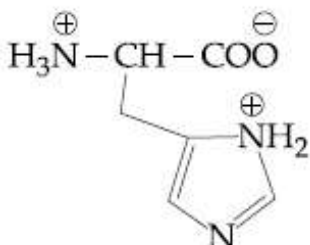

2.

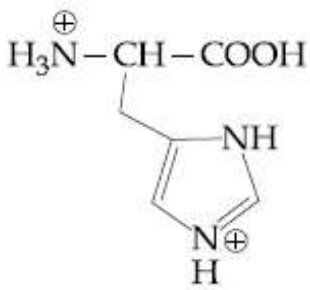

3.

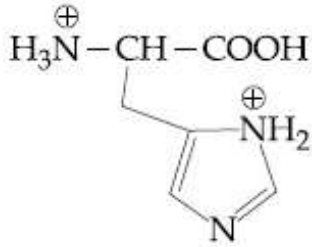

4.

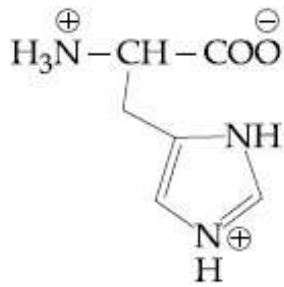

Question Number : 34 Question Type : MCQ Option Shuffling : Yes Display Question Number : Yes Single Line Question Option : No Option Orientation : Vertical

Correct Marks : 4 Wrong Marks : 1

एक सान्द्र अम्लीय विलयन (pH = 2) में, हिस्टीडीन की सही संरचना है :

Options :

1.

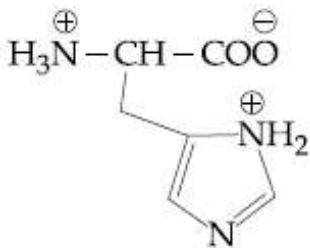

2.

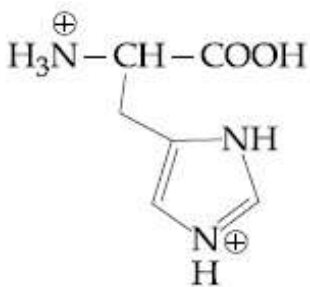

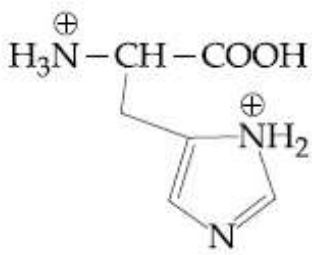

3.

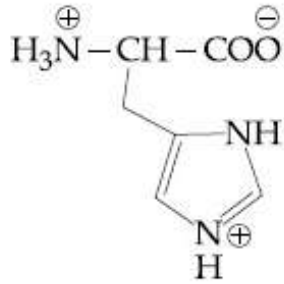

4.

Question Number : 34 Question Type : MCQ Option Shuffling : Yes Display Question Number : Yes Single Line Question Option : No Option Orientation : Vertical

Correct Marks : 4 Wrong Marks : 1

પ્રબળ એસિડિક માધ્યમ (pH = 2) માં હિસ્ટીડીનનું સાચું અંધારણ શોધો?

Options :

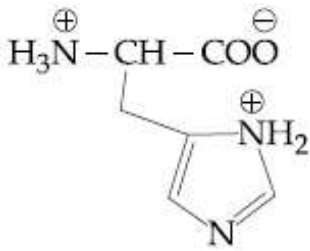

1.

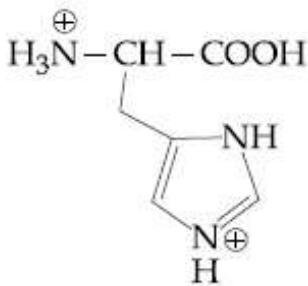

2.

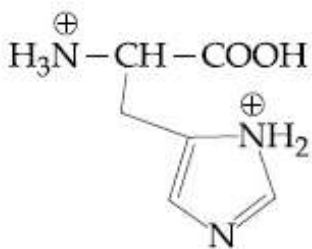

3.

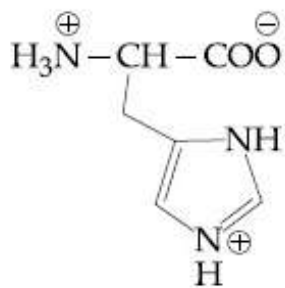

4.

Question Number : 35 Question Type : MCQ Option Shuffling : Yes Display Question Number : Yes Single Line Question Option : No Option Orientation : Vertical

Correct Marks : 4 Wrong Marks : 1

The major product of the following reaction is :

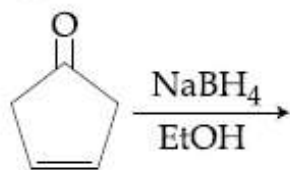

Options :

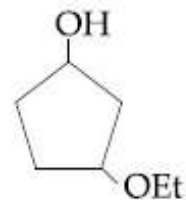
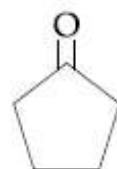
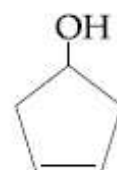
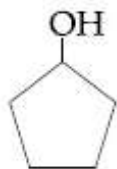

Question Number : 35 Question Type : MCQ Option Shuffling : Yes Display Question Number : Yes Single Line Question Option : No Option Orientation : Vertical

Correct Marks : 4 Wrong Marks : 1

निम्नलिखित अभिक्रिया का मुख्य उत्पाद है :

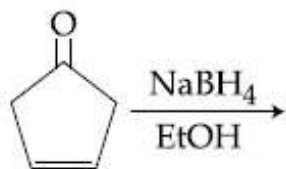

Options :

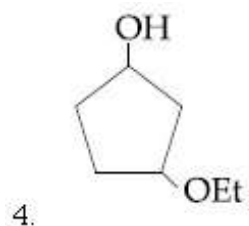
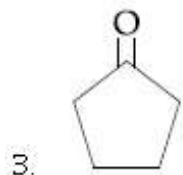
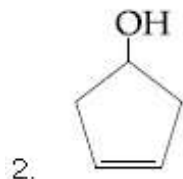
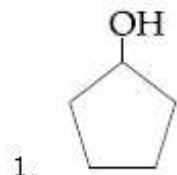

Question Number : 35 Question Type : MCQ Option Shuffling : Yes Display Question Number : Yes Single Line Question Option : No Option Orientation : Vertical

Correct Marks : 4 Wrong Marks : 1

નીચે આપેલી પ્રક્રિયાની મુખ્ય નીપજ શોધો ?

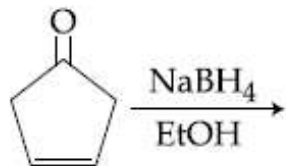

Options :

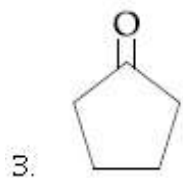
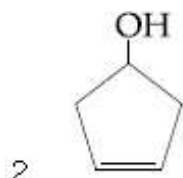
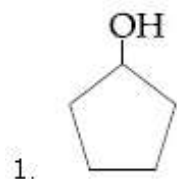

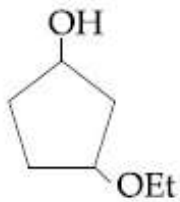

Question Number : 36 Question Type : MCQ Option Shuffling : Yes Display Question Number : Yes Single Line Question Option : No Option Orientation : Vertical

Correct Marks : 4 Wrong Marks : 1

The aldehydes which will **not** form Grignard product with one equivalent Grignard reagents are :

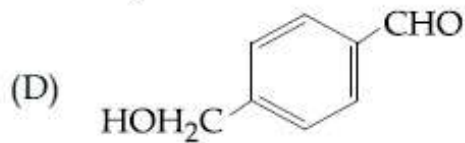
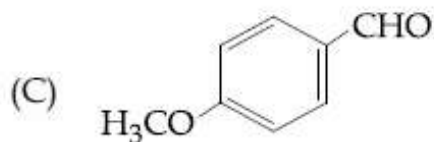
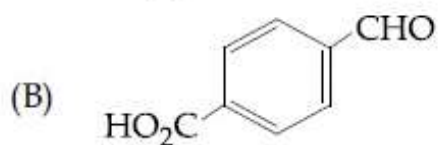

Options :

1. (B), (C)

2. (B), (D)



3. (B), (C), (D)

4. (C), (D)

Question Number : 36 Question Type : MCQ Option Shuffling : Yes Display Question Number : Yes Single Line Question Option : No Option Orientation : Vertical

Correct Marks : 4 Wrong Marks : 1

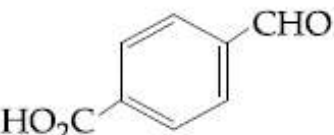
एक समतुल्य ग्रिन्यार अभिक्रिया के साथ ग्रिन्यार उत्पाद नहीं देने वाले ऐलिडहाइड हैं :

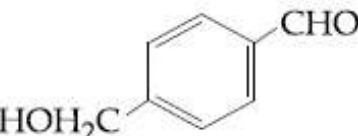
- (A) 
- (B) 
- (C) 
- (D) 

Options :

- (B), (C)
- (B), (D)
- (B), (C), (D)
- (C), (D)

Question Number : 36 Question Type : MCQ Option Shuffling : Yes Display Question Number : Yes Single Line Question Option : No Option Orientation : Vertical

Correct Marks : 4 Wrong Marks : 1

नीचे आपेला आलिडहाइडो पैकी क्या अक तुल्य जेटला ग्रीगनार्ड प्रकीयक साथे प्रकिया करी ग्रीगनार्ड पदार्थ आपता नथी ते/तेओ शोधो?

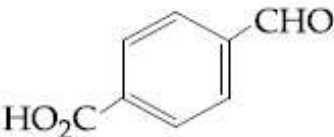
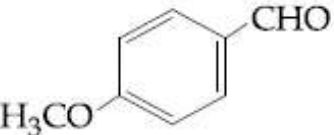
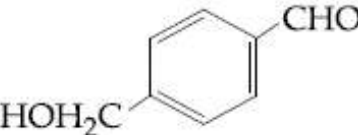
- (A) 
- (B) 
- (C) 
- (D) 

Options :

1. (B), (C)
2. (B), (D)
3. (B), (C), (D)
4. (C), (D)

Question Number : 37 Question Type : MCQ Option Shuffling : Yes Display Question Number : Yes Single Line Question Option : No Option Orientation : Vertical

Correct Marks : 4 Wrong Marks : 1

The increasing order of the reactivity of the following with LiAlH_4 is :

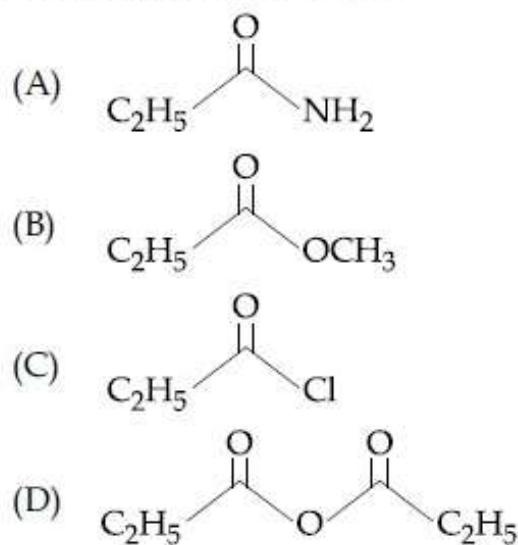

Options :

1. (A) < (B) < (C) < (D)
2. (B) < (A) < (D) < (C)
3. (A) < (B) < (D) < (C)
4. (B) < (A) < (C) < (D)

Question Number : 37 Question Type : MCQ Option Shuffling : Yes Display Question Number : Yes Single Line Question Option : No Option Orientation : Vertical

Correct Marks : 4 Wrong Marks : 1

निम्नलिखित की LiAlH_4 के साथ अभिक्रियाशीलता का बढ़ता क्रम है :

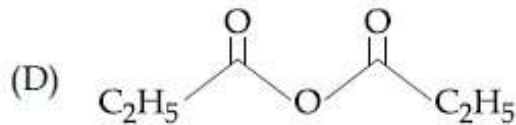
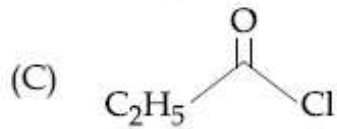
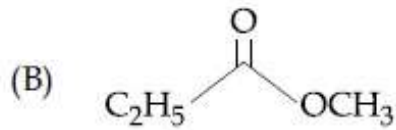
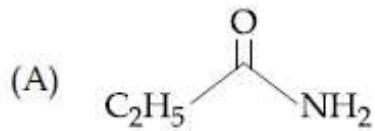

Options :

1. (A) < (B) < (C) < (D)
2. (B) < (A) < (D) < (C)
3. (A) < (B) < (D) < (C)
4. (B) < (A) < (C) < (D)

Question Number : 37 Question Type : MCQ Option Shuffling : Yes Display Question Number : Yes Single Line Question Option : No Option Orientation : Vertical

Correct Marks : 4 Wrong Marks : 1

नीचे आपेसानी LiAlH_4 साथेनी सक्रियतानो बढ़तो क्रम शोधो ?

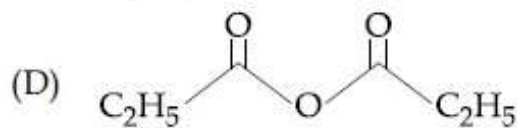
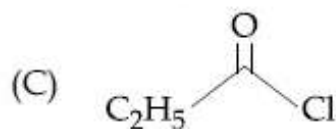
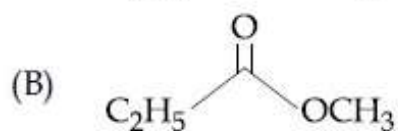
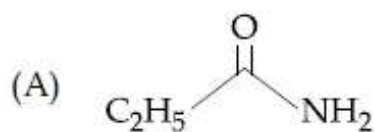

Options :

1. (A) < (B) < (C) < (D)
2. (B) < (A) < (D) < (C)

3. (A) < (B) < (D) < (C)

4. (B) < (A) < (C) < (D)

Question Number : 38 Question Type : MCQ Option Shuffling : Yes Display Question Number : Yes Single Line Question Option : No Option Orientation : Vertical

Correct Marks : 4 Wrong Marks : 1

The major product of the following reaction is :

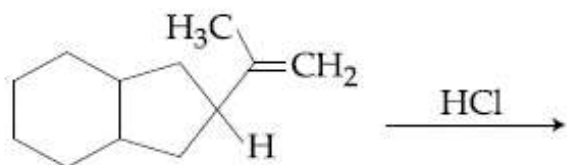

Options :

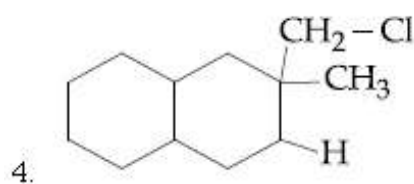
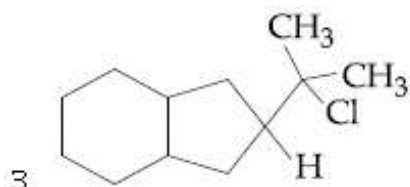
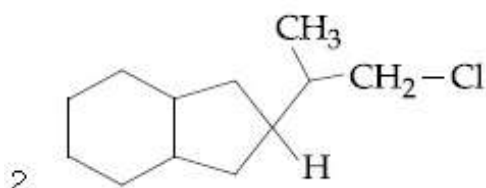
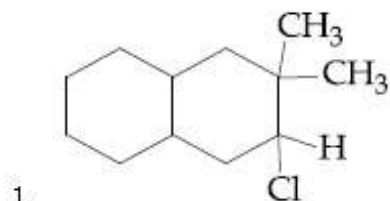

Question Number : 38 Question Type : MCQ Option Shuffling : Yes Display Question Number : Yes Single Line Question Option : No Option Orientation : Vertical

Correct Marks : 4 Wrong Marks : 1

निम्नलिखित अभिक्रिया का मुख्य उत्पाद है :

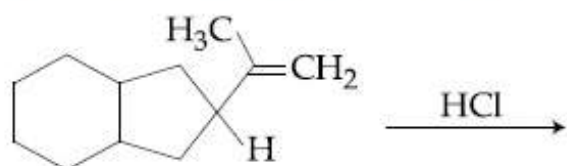

Options :

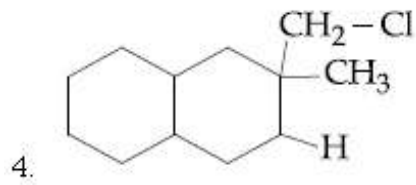
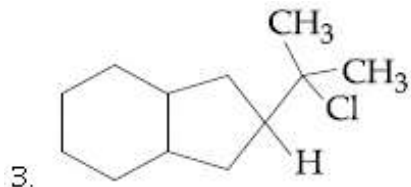
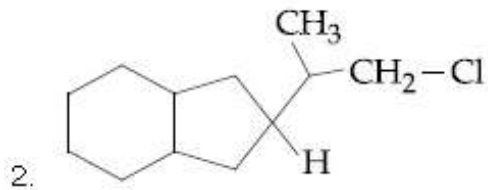
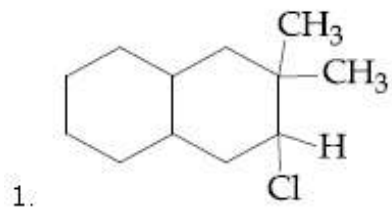

Question Number : 38 Question Type : MCQ Option Shuffling : Yes Display Question Number : Yes Single Line Question Option : No Option Orientation : Vertical

Correct Marks : 4 Wrong Marks : 1

નીચે આપેલી પ્રક્રિયાની મુખ્ય નીપજ શોધો?

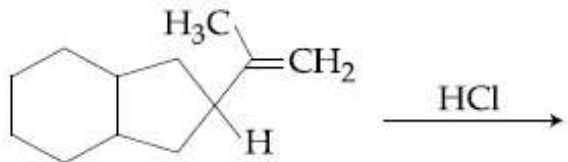

Options :

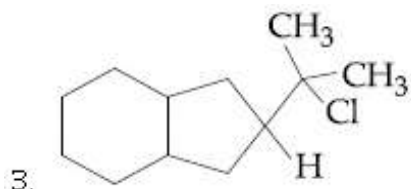
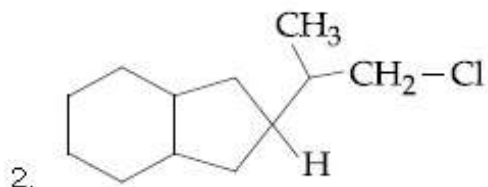
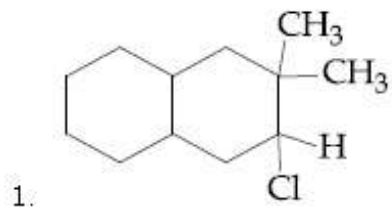

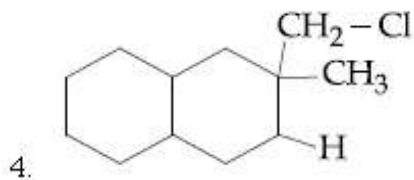

Question Number : 39 Question Type : MCQ Option Shuffling : Yes Display Question Number : Yes Single Line Question Option : No Option Orientation : Vertical

Correct Marks : 4 Wrong Marks : 1

The major product in the following conversion is :

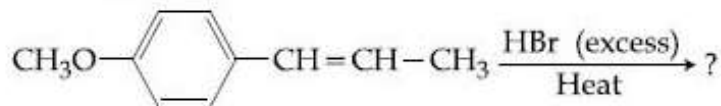

Options :

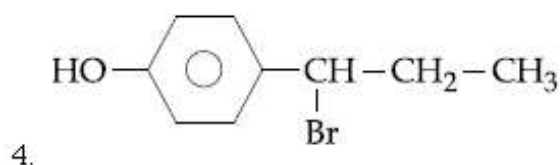
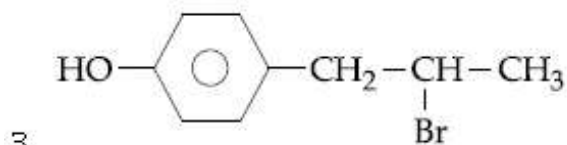
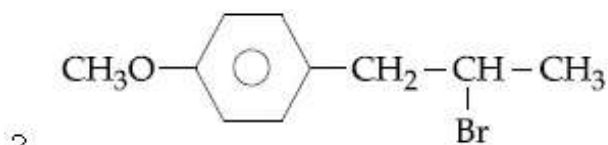
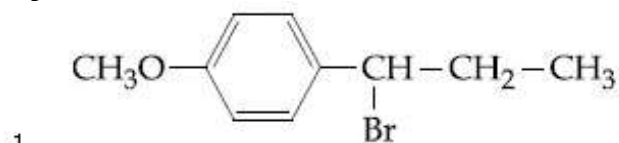

Question Number : 39 Question Type : MCQ Option Shuffling : Yes Display Question Number : Yes Single Line Question Option : No Option Orientation : Vertical

Correct Marks : 4 Wrong Marks : 1

निम्नलिखित रूपान्तरण में सही उत्पाद है :

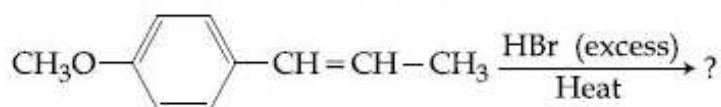

Options :

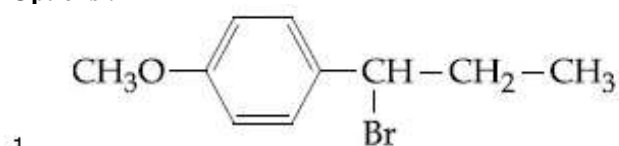

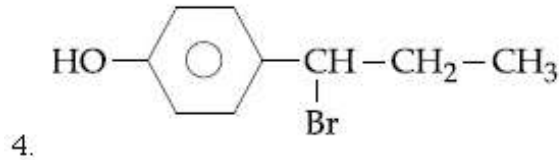
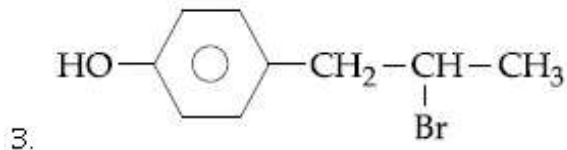
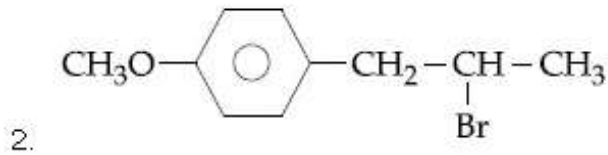

Question Number : 39 Question Type : MCQ Option Shuffling : Yes Display Question Number : Yes Single Line Question Option : No Option Orientation : Vertical

Correct Marks : 4 Wrong Marks : 1

નીચે આપેલી પ્રક્રિયાની મુખ્ય નીપજ શોધો ?

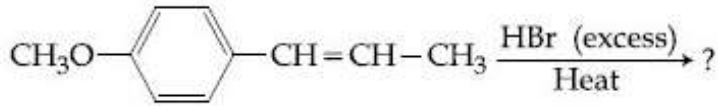

Options :

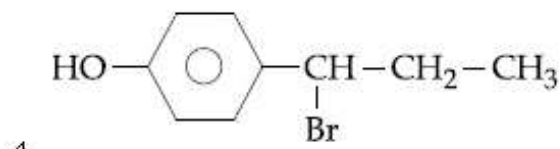
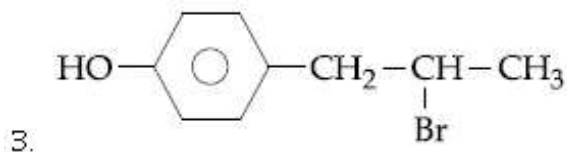
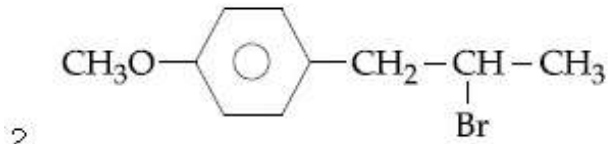
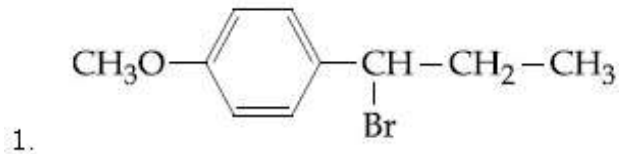

Question Number : 40 Question Type : MCQ Option Shuffling : Yes Display Question Number : Yes Single Line Question Option : No Option Orientation : Vertical

Correct Marks : 4 Wrong Marks : 1

The major product of the following reaction is :

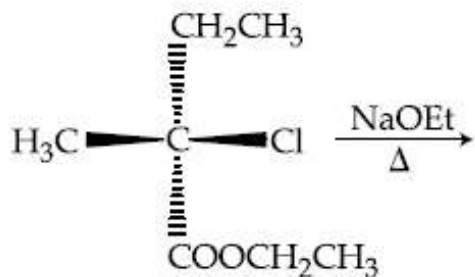

Options :

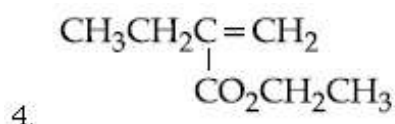
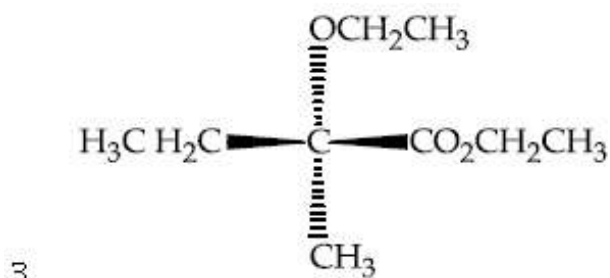
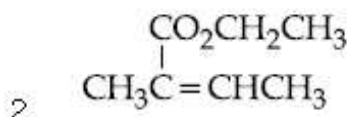
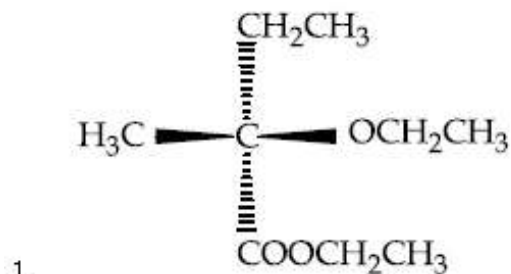

Question Number : 40 Question Type : MCQ Option Shuffling : Yes Display Question Number : Yes Single Line Question Option : No Option Orientation : Vertical

Correct Marks : 4 Wrong Marks : 1

निम्नलिखित अभिक्रिया का मुख्य उत्पाद है :

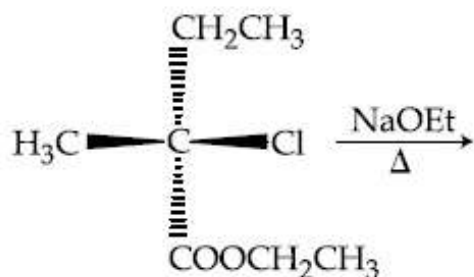

Options :

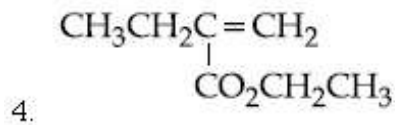
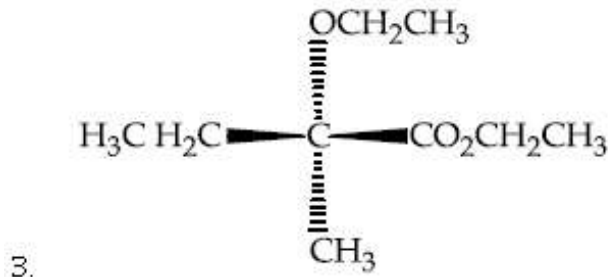
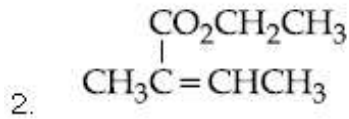
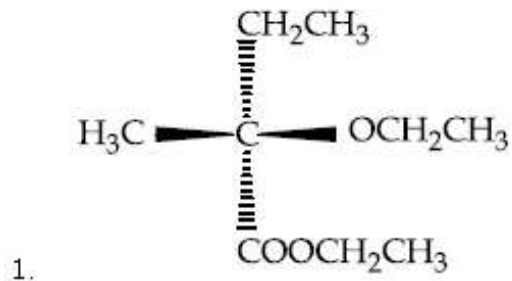

Question Number : 40 Question Type : MCQ Option Shuffling : Yes Display Question Number : Yes Single Line Question Option : No Option Orientation : Vertical

Correct Marks : 4 Wrong Marks : 1

નીચે આપેલી પ્રક્રિયાની મુખ્ય નીપજ શોધો?

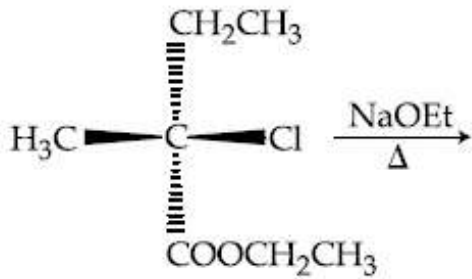

Options :

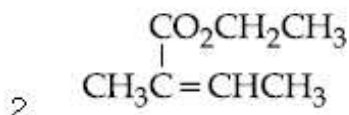
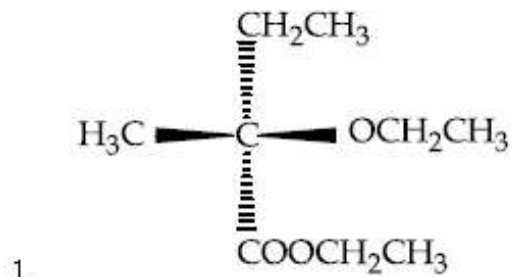

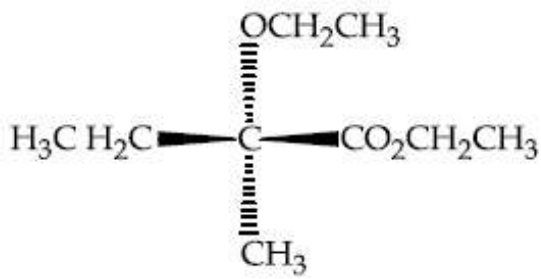

3.

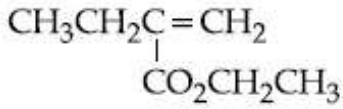

4.

Question Number : 41 Question Type : MCQ Option Shuffling : Yes Display Question Number : Yes Single Line Question Option : No Option Orientation : Vertical

Correct Marks : 4 Wrong Marks : 1

The element that shows greater ability to form $p\pi - p\pi$ multiple bonds, is :

Options :

1. Si
2. C
3. Ge
4. Sn

Question Number : 41 Question Type : MCQ Option Shuffling : Yes Display Question Number : Yes Single Line Question Option : No Option Orientation : Vertical

Correct Marks : 4 Wrong Marks : 1

$p\pi - p\pi$ बहुबंध बनाने की प्रबल योग्यता रखने वाला तत्व है :

Options :

1. Si
2. C
3. Ge
4. Sn

Question Number : 41 Question Type : MCQ Option Shuffling : Yes Display Question Number : Yes Single Line Question Option : No Option Orientation : Vertical

Correct Marks : 4 Wrong Marks : 1

તત્વ કે જે, $p\pi - p\pi$ બહુગુણિત બંધો બનાવવાની વધુ ક્ષમતા દર્શાવે છે?

Options :

1. Si
2. C
3. Ge
4. Sn

Question Number : 42 Question Type : MCQ Option Shuffling : Yes Display Question Number : Yes Single Line Question Option : No Option Orientation : Vertical

Correct Marks : 4 Wrong Marks : 1

The pair that does NOT require calcination is :

Options :

1. ZnO and $\text{Fe}_2\text{O}_3 \cdot x\text{H}_2\text{O}$
2. ZnCO_3 and CaO
3. ZnO and MgO
4. Fe_2O_3 and $\text{CaCO}_3 \cdot \text{MgCO}_3$

Question Number : 42 Question Type : MCQ Option Shuffling : Yes Display Question Number : Yes Single Line Question Option : No Option Orientation : Vertical

Correct Marks : 4 Wrong Marks : 1

युग्म जिसके लिए निस्तापन की आवश्यकता नहीं होती है, वह है :

Options :

1. ZnO तथा $\text{Fe}_2\text{O}_3 \cdot x\text{H}_2\text{O}$
2. ZnCO_3 तथा CaO
3. ZnO तथा MgO
4. Fe_2O_3 तथा $\text{CaCO}_3 \cdot \text{MgCO}_3$

Question Number : 42 Question Type : MCQ Option Shuffling : Yes Display Question Number : Yes Single Line Question Option : No Option Orientation : Vertical

Correct Marks : 4 Wrong Marks : 1

नीचे आपेली ब्रोड पैकी कर्छ अेकमां निस्तापन/भस्मीकरण नी जरूरीयात नथी?

Options :

1. ZnO અને Fe₂O₃ · xH₂O

2. ZnCO₃ અને CaO

3. ZnO અને MgO

4. Fe₂O₃ અને CaCO₃ · MgCO₃

Question Number : 43 Question Type : MCQ Option Shuffling : Yes Display Question Number : Yes Single Line Question Option : No Option Orientation : Vertical

Correct Marks : 4 Wrong Marks : 1

The volume strength of 1M H₂O₂ is :

(Molar mass of H₂O₂ = 34 g mol⁻¹)

Options :

1. 5.6

2. 11.35

3. 16.8

4. 22.4

Question Number : 43 Question Type : MCQ Option Shuffling : Yes Display Question Number : Yes Single Line Question Option : No Option Orientation : Vertical

Correct Marks : 4 Wrong Marks : 1

1M H₂O₂ का आयतन सामर्थ्य है (H₂O₂ का मोलर द्रव्यमान = 34 ग्रा. मोल⁻¹)

Options :

1. 5.6

2. 11.35

3. 16.8

4. 22.4

Question Number : 43 Question Type : MCQ Option Shuffling : Yes Display Question Number : Yes Single Line Question Option : No Option Orientation : Vertical

Correct Marks : 4 Wrong Marks : 1

1M H₂O₂ ની કદ પ્રબળતા કેટલી ?

(H₂O₂ નું મોલર દળ = 34 g mol⁻¹)

Options :

1. 5.6
2. 11.35
3. 16.8
4. 22.4

Question Number : 44 Question Type : MCQ Option Shuffling : Yes Display Question Number : Yes Single Line Question Option : No Option Orientation : Vertical

Correct Marks : 4 Wrong Marks : 1

The correct statement(s) among I to III with respect to potassium ions that are abundant within the cell fluids is/are :

- I. They activate many enzymes
- II. They participate in the oxidation of glucose to produce ATP
- III. Along with sodium ions, they are responsible for the transmission of nerve signals

Options :

1. I, II and III
2. I and II only
3. III only
4. I and III only

Question Number : 44 Question Type : MCQ Option Shuffling : Yes Display Question Number : Yes Single Line Question Option : No Option Orientation : Vertical

Correct Marks : 4 Wrong Marks : 1

कोशिका तरल में बाहुल्य रूप में पाये जाने वाले पोटेशियम आयनों के संबंध में I से III में से सही कथन है/हैं?

- I. वे कई एंजाइमों को सक्रिय करते हैं।
- II. वे ग्लूकोस के आक्सीकरण द्वारा ATP के बनाने में भागीदारी करते हैं।
- III. सोडियम आयन के साथ, तंत्रिकाओं के संकेतों के संचरण के लिए जिम्मेदार होते हैं।

Options :

1. I, II तथा III

2. કેવલ I તથા II
3. કેવલ III
4. કેવલ I તથા III

Question Number : 44 Question Type : MCQ Option Shuffling : Yes Display Question Number : Yes Single Line Question Option : No Option Orientation : Vertical

Correct Marks : 4 Wrong Marks : 1

પોટેશિયમ આયન કે જે કોશ પ્રવાહી (cell fluids)માં પ્રચુર માત્રામાં હોય છે. તેના સંદર્ભમાં વિધાનો I થી III પૈકી કયા વિધાન(નો) સાચા છે ?

- I. તેઓ ઘણા ઉત્સેચકોને સક્રીય કરે છે.
- II. તેઓ ગ્લુકોઝના ઓક્સિડેશનમાં ભાગ લઈ ATP બનાવે છે.
- III. સોડિયમ આયન સાથે તેવો ચેતા સંકેત ના વહનમાટે જવાબદાર છે.

Options :

1. I, II અને III
2. ફક્ત I અને II
3. ફક્ત III
4. ફક્ત I અને III

Question Number : 45 Question Type : MCQ Option Shuffling : Yes Display Question Number : Yes Single Line Question Option : No Option Orientation : Vertical

Correct Marks : 4 Wrong Marks : 1

The element that does NOT show catenation is :

Options :

1. Si
2. Ge
3. Sn
4. Pb

Question Number : 45 Question Type : MCQ Option Shuffling : Yes Display Question Number : Yes Single Line Question Option : No Option Orientation : Vertical

Correct Marks : 4 Wrong Marks : 1

श्रृंखलन नहीं प्रदर्शित करने वाला तत्व है :

Options :

1. Si
2. Ge
3. Sn
4. Pb

Question Number : 45 Question Type : MCQ Option Shuffling : Yes Display Question Number : Yes Single Line Question Option : No Option Orientation : Vertical

Correct Marks : 4 Wrong Marks : 1

तत्व के जे कॅटेनेशन दर्शावती नहीं ते शोधो ?

Options :

1. Si
2. Ge
3. Sn
4. Pb

Question Number : 46 Question Type : MCQ Option Shuffling : Yes Display Question Number : Yes Single Line Question Option : No Option Orientation : Vertical

Correct Marks : 4 Wrong Marks : 1

Chlorine on reaction with hot and concentrated sodium hydroxide gives :

Options :

1. ClO_3^- and ClO_2^-
2. Cl^- and ClO_3^-
3. Cl^- and ClO_2^-
4. Cl^- and ClO^-

Question Number : 46 Question Type : MCQ Option Shuffling : Yes Display Question Number : Yes Single Line Question Option : No Option Orientation : Vertical

Correct Marks : 4 Wrong Marks : 1

गर्म तथा सान्द्र सोडियम हाइड्रॉक्साइड के साथ क्लोरीन की अभिक्रिया देती है :

Options :

1. ClO_3^- तथा ClO_2^-
2. Cl^- तथा ClO_3^-
3. Cl^- तथा ClO_2^-
4. Cl^- तथा ClO^-

Question Number : 46 Question Type : MCQ Option Shuffling : Yes Display Question Number : Yes Single Line Question Option : No Option Orientation : Vertical

Correct Marks : 4 Wrong Marks : 1

क्लोरीन गरम अने सांद्र सोडियम हाइड्रॉक्साइड साथे प्रक्रिया करी शुं बनावशे ते शोधो?

Options :

1. ClO_3^- अने ClO_2^-
2. Cl^- अने ClO_3^-
3. Cl^- अने ClO_2^-
4. Cl^- अने ClO^-

Question Number : 47 Question Type : MCQ Option Shuffling : Yes Display Question Number : Yes Single Line Question Option : No Option Orientation : Vertical

Correct Marks : 4 Wrong Marks : 1

The correct order of atomic radii is :

Options :

1. $\text{Eu} > \text{Ce} > \text{Ho} > \text{N}$
2. $\text{Ce} > \text{Eu} > \text{Ho} > \text{N}$
3. $\text{N} > \text{Ce} > \text{Eu} > \text{Ho}$
4. $\text{Ho} > \text{N} > \text{Eu} > \text{Ce}$

Question Number : 47 Question Type : MCQ Option Shuffling : Yes Display Question Number : Yes Single Line Question Option : No Option Orientation : Vertical

Correct Marks : 4 Wrong Marks : 1

परमाणु त्रिज्याओं का सही क्रम है :

Options :

1. $\text{Eu} > \text{Ce} > \text{Ho} > \text{N}$
2. $\text{Ce} > \text{Eu} > \text{Ho} > \text{N}$
3. $\text{N} > \text{Ce} > \text{Eu} > \text{Ho}$
4. $\text{Ho} > \text{N} > \text{Eu} > \text{Ce}$

Question Number : 47 Question Type : MCQ Option Shuffling : Yes Display Question Number : Yes Single Line Question Option : No Option Orientation : Vertical

Correct Marks : 4 Wrong Marks : 1

परमाणु त्रिज्याओं का सही क्रम शोधो?

Options :

1. $\text{Eu} > \text{Ce} > \text{Ho} > \text{N}$
2. $\text{Ce} > \text{Eu} > \text{Ho} > \text{N}$
3. $\text{N} > \text{Ce} > \text{Eu} > \text{Ho}$
4. $\text{Ho} > \text{N} > \text{Eu} > \text{Ce}$

Question Number : 48 Question Type : MCQ Option Shuffling : Yes Display Question Number : Yes Single Line Question Option : No Option Orientation : Vertical

Correct Marks : 4 Wrong Marks : 1

The magnetic moment of an octahedral homoleptic $\text{Mn}(\text{II})$ complex is 5.9 BM. The suitable ligand for this complex is :

Options :

1. CO
2. NCS^-
3. CN^-
4. ethylenediamine

Question Number : 48 Question Type : MCQ Option Shuffling : Yes Display Question Number : Yes Single Line Question Option : No Option Orientation : Vertical

Correct Marks : 4 Wrong Marks : 1

एक अष्टफलक होमोलेप्टिक $Mn(II)$ के संकुल का चुंबकीय आघूर्ण 5.9 BM है। इस संकुल के लिए उपयुक्त संलग्नी है :

Options :

1. CO
2. NCS^-
3. CN^-
4. ethylenediamine

Question Number : 48 Question Type : MCQ Option Shuffling : Yes Display Question Number : Yes Single Line Question Option : No Option Orientation : Vertical

Correct Marks : 4 Wrong Marks : 1

अष्टफलकीय होमोलेप्टिक $Mn(II)$ का संकुल चुंबकीय आघूर्ण 5.9 BM है। तो आ संकुल के लिए उपयुक्त लिगान्ड शोधो ?

Options :

1. CO
2. NCS^-
3. CN^-
4. एथिलेनडायायमेन

Question Number : 49 Question Type : MCQ Option Shuffling : Yes Display Question Number : Yes Single Line Question Option : No Option Orientation : Vertical

Correct Marks : 4 Wrong Marks : 1

The upper stratosphere consisting of the ozone layer protects us from the sun's radiation that falls in the wavelength region of :

Options :

1. 0.8 - 1.5 nm
2. 200 - 315 nm
3. 400 - 550 nm
4. 600 - 750 nm

Question Number : 49 Question Type : MCQ Option Shuffling : Yes Display Question Number : Yes Single Line Question Option : No Option Orientation : Vertical

Correct Marks : 4 Wrong Marks : 1

ऊपरी समतापमंडल जिसमें उपस्थित ओजोन परत हमें सूर्य के विकिरण से बचाती है, उसका तरंगदैर्घ्य क्षेत्र है :

Options :

1. 0.8 - 1.5 nm
2. 200 - 315 nm
3. 400 - 550 nm
4. 600 - 750 nm

Question Number : 49 Question Type : MCQ Option Shuffling : Yes Display Question Number : Yes Single Line Question Option : No Option Orientation : Vertical

Correct Marks : 4 Wrong Marks : 1

समताप आवरणना उपरना भागमां आवेलु ओजोन नुं स्तर, आपणुं सूर्यना विकिरणोथी रक्षा करे छे. आ विकिरणोनी तरंगलंबाईनो विस्तार नीचेनामांथी शोधो ?

Options :

1. 0.8 - 1.5 nm
2. 200 - 315 nm
3. 400 - 550 nm
4. 600 - 750 nm

Question Number : 50 Question Type : MCQ Option Shuffling : Yes Display Question Number : Yes Single Line Question Option : No Option Orientation : Vertical

Correct Marks : 4 Wrong Marks : 1

The compound that is NOT a common component of photochemical smog is :

Options :

1. O_3
2. $CH_2=CHCHO$
3. CF_2Cl_2

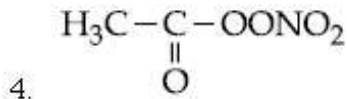

Question Number : 50 Question Type : MCQ Option Shuffling : Yes Display Question Number : Yes Single Line Question Option : No Option Orientation : Vertical

Correct Marks : 4 Wrong Marks : 1

प्रकाश रासायनिक धूमकुहा का जो सामान्य संघटक नहीं है, वह यौगिक है :

Options :

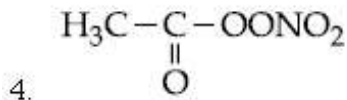
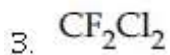
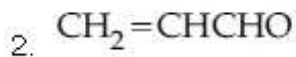
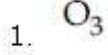

Question Number : 50 Question Type : MCQ Option Shuffling : Yes Display Question Number : Yes Single Line Question Option : No Option Orientation : Vertical

Correct Marks : 4 Wrong Marks : 1

नीचे आपेला संयोजनो पैकी कयो अेक घटक सामान्य रीते प्रकाश रासायनिक धुमधुम्भसनो भाग नथी?

Options :

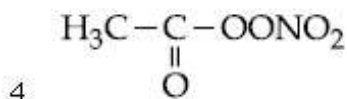
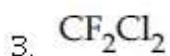
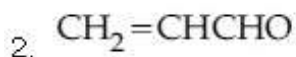
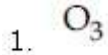

Question Number : 51 Question Type : MCQ Option Shuffling : Yes Display Question Number : Yes Single Line Question Option : No Option Orientation : Vertical

Correct Marks : 4 Wrong Marks : 1

8 g of NaOH is dissolved in 18 g of H_2O . Mole fraction of NaOH in solution and molality (in mol kg^{-1}) of the solution respectively are :

Options :

1. 0.167, 11.11
2. 0.2, 11.11
3. 0.167, 22.20
4. 0.2, 22.20

Question Number : 51 Question Type : MCQ Option Shuffling : Yes Display Question Number : Yes Single Line Question Option : No Option Orientation : Vertical

Correct Marks : 4 Wrong Marks : 1

8 g NaOH को 18 g H₂O में घोला गया है। विलयन में NaOH का मोलांश तथा विलयन की मोलालिटी (मोल प्रति किलोग्राम) क्रमशः है :

Options :

1. 0.167, 11.11
2. 0.2, 11.11
3. 0.167, 22.20
4. 0.2, 22.20

Question Number : 51 Question Type : MCQ Option Shuffling : Yes Display Question Number : Yes Single Line Question Option : No Option Orientation : Vertical

Correct Marks : 4 Wrong Marks : 1

8 g NaOH ने 18 g H₂O मां ओगाणवामां आवे छे तो द्रावणामां अनुक्रमे NaOH नो मोल अंश अने मोलालिटी (mol kg⁻¹मां) शोधो?

Options :

1. 0.167, 11.11
2. 0.2, 11.11
3. 0.167, 22.20
4. 0.2, 22.20

Question Number : 52 Question Type : MCQ Option Shuffling : Yes Display Question Number : Yes Single Line Question Option : No Option Orientation : Vertical

Correct Marks : 4 Wrong Marks : 1

An open vessel at 27°C is heated until two fifth of the air (assumed as an ideal gas) in it has escaped from the vessel. Assuming that the volume of the vessel remains constant, the temperature at which the vessel has been heated is :

Options :

1. 500°C
2. 500 K
3. 750 K
4. 750°C

Question Number : 52 Question Type : MCQ Option Shuffling : Yes Display Question Number : Yes Single Line Question Option : No Option Orientation : Vertical

Correct Marks : 4 Wrong Marks : 1

27°C पर स्थित एक खुले पात्र को तब तक गर्म किया जाता है जब तक इसमें उपस्थित वायु (आदर्श गैस मानते हुए) के दो के पाँचवें भाग ($2/5$) पात्र से निकल नहीं जाता। यह मानकर कि पात्र का आयतन स्थिर है, ताप जिस पर पात्र को गर्म किया गया है, वह है :

Options :

1. 500°C
2. 500 K
3. 750 K
4. 750°C

Question Number : 52 Question Type : MCQ Option Shuffling : Yes Display Question Number : Yes Single Line Question Option : No Option Orientation : Vertical

Correct Marks : 4 Wrong Marks : 1

27°C એક ખુલ્લા પાત્રને ($2/5$) જેટલી હવા (આદર્શવાયુ તરીકે ધારીને) ઊડી જાય ત્યાં સુધી ગરમ કરવામાં આવે છે. ધારો કે પાત્રનું કદ અચળ રહે છે. તો કેટલા તાપમાને પાત્રને ગરમ કરવામાં આવ્યું તે શોધો?

Options :

1. 500°C

2. 500 K
3. 750 K
4. 750 °C

Question Number : 53 Question Type : MCQ Option Shuffling : Yes Display Question Number : Yes Single Line Question Option : No Option Orientation : Vertical

Correct Marks : 4 Wrong Marks : 1

If the de Broglie wavelength of the electron in n^{th} Bohr orbit in a hydrogenic atom is equal to $1.5 \pi a_0$ (a_0 is Bohr radius), then the value of n/z is :

Options :

1. 1.0
2. 1.50
3. 0.75
4. 0.40

Question Number : 53 Question Type : MCQ Option Shuffling : Yes Display Question Number : Yes Single Line Question Option : No Option Orientation : Vertical

Correct Marks : 4 Wrong Marks : 1

यदि एक हाइड्रोजन परमाणु में, n^{th} बोर कक्षक में स्थित इलेक्ट्रॉन का दे ब्रोग्ली तरंगदैर्घ्य $1.5 \pi a_0$ के बराबर है, तो n/z का मान है : (a_0 बोर त्रिज्या है)

Options :

1. 1.0
2. 1.50
3. 0.75
4. 0.40

Question Number : 53 Question Type : MCQ Option Shuffling : Yes Display Question Number : Yes Single Line Question Option : No Option Orientation : Vertical

Correct Marks : 4 Wrong Marks : 1

હાઇડ્રોજનનીય પરમાણુમાં n મી (n^{th}) બહોર કક્ષકમાં ઇલેક્ટ્રોનની ડી-બ્રોગ્લી તરંગલંબાઈ $1.5 \pi a_0$ જ્યાં (a_0 બહોર ત્રિજ્યા) ને બરાબર છે તો n/z નું મુલ્ય શોધો ?

Options :

1. 1.0
2. 1.50
3. 0.75
4. 0.40

Question Number : 54 Question Type : MCQ Option Shuffling : Yes Display Question Number : Yes Single Line Question Option : No Option Orientation : Vertical

Correct Marks : 4 Wrong Marks : 1

The combination of plots which does not represent isothermal expansion of an ideal gas is :

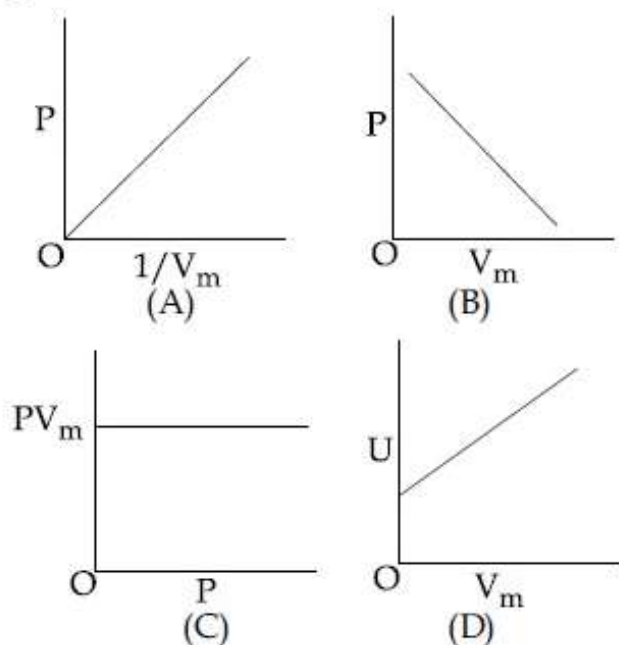

Options :

1. (B) and (C)
2. (A) and (D)
3. (B) and (D)
4. (A) and (C)

Question Number : 54 Question Type : MCQ Option Shuffling : Yes Display Question Number : Yes Single Line Question Option : No Option Orientation : Vertical

Correct Marks : 4 Wrong Marks : 1

एक आदर्श गैस के समतापीय प्रसरण को नहीं निरूपित करने वाले प्लोटों का संयोजन है :

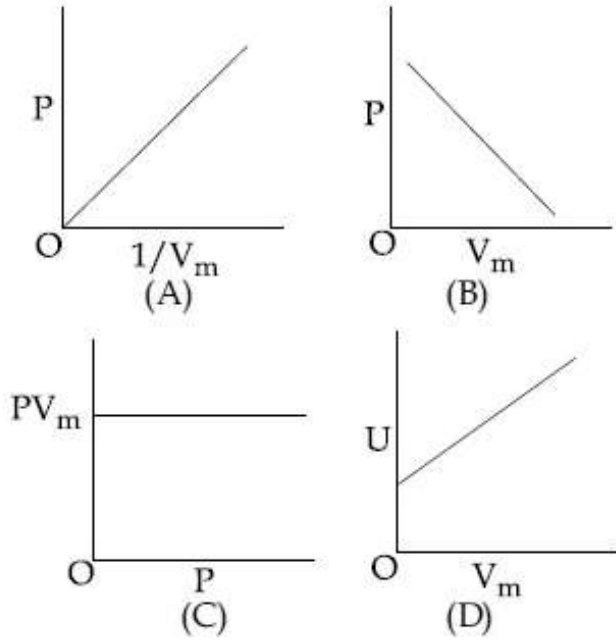

Options :

1. (B) तथा (C)
2. (A) तथा (D)
3. (B) तथा (D)
4. (A) तथा (C)

Question Number : 54 Question Type : MCQ Option Shuffling : Yes Display Question Number : Yes Single Line Question Option : No Option Orientation : Vertical

Correct Marks : 4 Wrong Marks : 1

आदर्शवायु भाटे जे आलेखनी जेड समतापी विस्तारण दर्शावती नथी ते शोधो ?

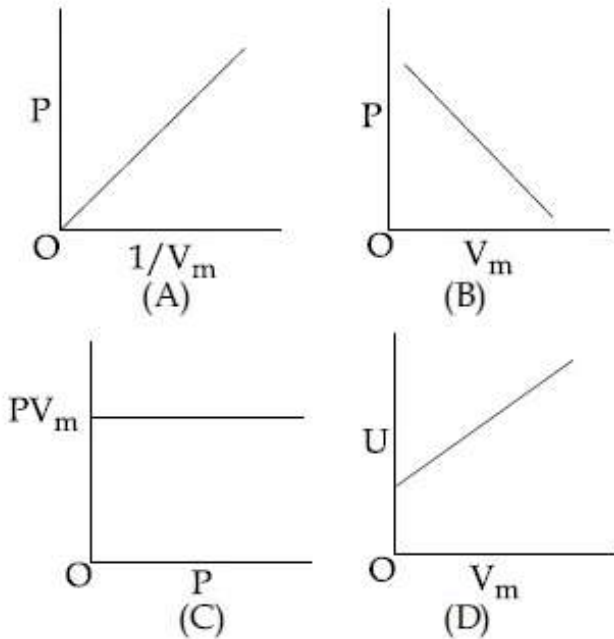

Options :

1. (B) અને (C)
2. (A) અને (D)
3. (B) અને (D)
4. (A) અને (C)

Question Number : 55 Question Type : MCQ Option Shuffling : Yes Display Question Number : Yes Single Line Question Option : No Option Orientation : Vertical

Correct Marks : 4 Wrong Marks : 1

Given :

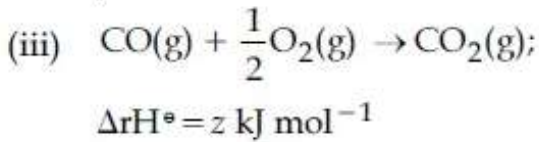
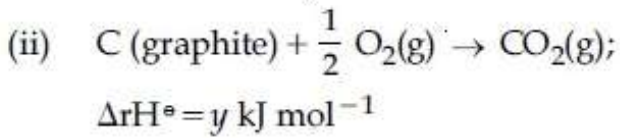
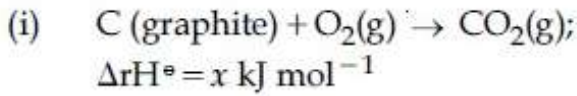

Based on the above thermochemical equations, find out which one of the following algebraic relationships is correct?

Options :

1. $x = y + z$
2. $x = y - z$
3. $z = x + y$
4. $y = 2z - x$

Question Number : 55 Question Type : MCQ Option Shuffling : Yes Display Question Number : Yes Single Line Question Option : No Option Orientation : Vertical

Correct Marks : 4 Wrong Marks : 1

આપેલ ,

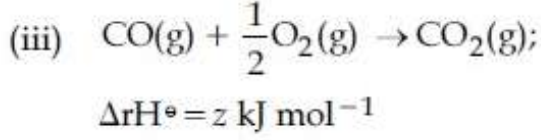
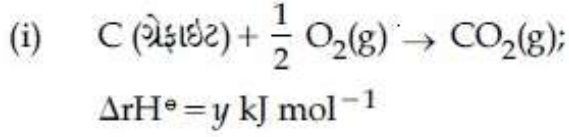
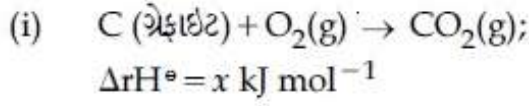

ઉપરોક્ત, ઊષ્માસાયણિક સમીકરણો ના આધારે નીચેનામાંથી કયો બીજગણિતિક સંબંધ સાચો છે ?

Options :

1. $x = y + z$
2. $x = y - z$
3. $z = x + y$
4. $y = 2z - x$

Question Number : 55 Question Type : MCQ Option Shuffling : Yes Display Question Number : Yes Single Line Question Option : No Option Orientation : Vertical

Correct Marks : 4 Wrong Marks : 1

दिया गया है :

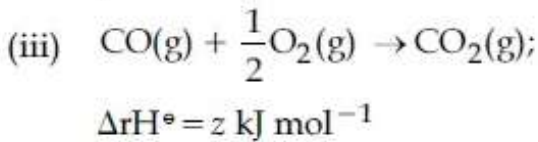
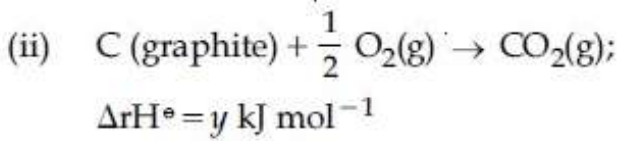
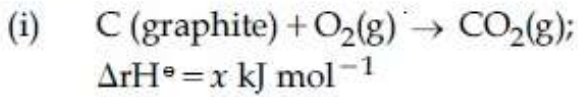

उपर्युक्त ऊष्मासायनिक समीकरणों के आधार पर बताइये कि नीचे दिए गये बीजगणितीय संबंधों में से कौन सा सही है ?

Options :

1. $x = y + z$
2. $x = y - z$
3. $z = x + y$

4. $y = 2z - x$

Question Number : 56 Question Type : MCQ Option Shuffling : Yes Display Question Number : Yes Single Line Question Option : No Option Orientation : Vertical

Correct Marks : 4 Wrong Marks : 1

Molecules of benzoic acid (C_6H_5COOH) dimerise in benzene. 'w' g of the acid dissolved in 30 g of benzene shows a depression in freezing point equal to 2 K. If the percentage association of the acid to form dimer in the solution is 80, then w is :
(Given that $K_f = 5 \text{ K kg mol}^{-1}$, Molar mass of benzoic acid = 122 g mol^{-1})

Options :

1. 1.0 g
2. 1.8 g
3. 2.4 g
4. 1.5 g

Question Number : 56 Question Type : MCQ Option Shuffling : Yes Display Question Number : Yes Single Line Question Option : No Option Orientation : Vertical

Correct Marks : 4 Wrong Marks : 1

बेन्जोइक अम्ल (C_6H_5COOH) के अणु बेन्जीन में द्वितयित होते हैं। 30 g बेन्जीन में घुलित 'w' g अम्ल 2 K के बराबर हिमांक में अवनमन प्रदर्शित करता है। यदि विलयन में अम्ल के संगुणन का प्रतिशत 80 है तो w का मान है :

(दिया गया है, $K_f = 5 \text{ K kg mol}^{-1}$ बेन्जोइक एसिड का मोलर द्रव्यमान = 122 g mol^{-1})

Options :

1. 1.0 g
2. 1.8 g
3. 2.4 g
4. 1.5 g

Question Number : 56 Question Type : MCQ Option Shuffling : Yes Display Question Number : Yes Single Line Question Option : No Option Orientation : Vertical

Correct Marks : 4 Wrong Marks : 1

બેન્ઝોઇક એસિડ (C_6H_5COOH) ના અણુઓ બેન્ઝીનમાં દ્વિઆણુ બનાવે છે. 'w' g એસિડને 30 g બેન્ઝીનમાં ઓગાળવામાં આવે તો ઠારબિંદુ અવનયન $2 K$ ને બરાબર થાય છે. જો એસિડની દ્રાવણમાં દ્વિઆણુ બનાવાની સુયોજન ટકાવારી (percentage association) 80 હોય તો w શોધો?

(આપેલ, $K_f = 5 K \text{ kg mol}^{-1}$ બેન્ઝોઇક એસિડનું મોલર દળ = 122 g mol^{-1})

Options :

1. 1.0 g
2. 1.8 g
3. 2.4 g
4. 1.5 g

Question Number : 57 Question Type : MCQ Option Shuffling : Yes Display Question Number : Yes Single Line Question Option : No Option Orientation : Vertical

Correct Marks : 4 Wrong Marks : 1

If K_{sp} of Ag_2CO_3 is 8×10^{-12} , the molar solubility of Ag_2CO_3 in 0.1 M AgNO_3 is :

Options :

1. $8 \times 10^{-10} \text{ M}$
2. $8 \times 10^{-11} \text{ M}$
3. $8 \times 10^{-12} \text{ M}$
4. $8 \times 10^{-13} \text{ M}$

Question Number : 57 Question Type : MCQ Option Shuffling : Yes Display Question Number : Yes Single Line Question Option : No Option Orientation : Vertical

Correct Marks : 4 Wrong Marks : 1

यदि Ag_2CO_3 का K_{sp} 8×10^{-12} है तो Ag_2CO_3 की 0.1 M AgNO_3 में मोलर विलेयता है :

Options :

1. $8 \times 10^{-10} \text{ M}$
2. $8 \times 10^{-11} \text{ M}$

3. $8 \times 10^{-12} \text{ M}$

4. $8 \times 10^{-13} \text{ M}$

Question Number : 57 Question Type : MCQ Option Shuffling : Yes Display Question Number : Yes Single Line Question Option : No Option Orientation : Vertical

Correct Marks : 4 Wrong Marks : 1

જો Ag_2CO_3 નો K_{sp} 8×10^{-12} છે, તો 0.1 M AgNO_3 માં Ag_2CO_3 ની મોલર દ્રાવ્યતા શોધો?

Options :

1. $8 \times 10^{-10} \text{ M}$

2. $8 \times 10^{-11} \text{ M}$

3. $8 \times 10^{-12} \text{ M}$

4. $8 \times 10^{-13} \text{ M}$

Question Number : 58 Question Type : MCQ Option Shuffling : Yes Display Question Number : Yes Single Line Question Option : No Option Orientation : Vertical

Correct Marks : 4 Wrong Marks : 1

Λ_m° for NaCl, HCl and NaA are 126.4, 425.9 and $100.5 \text{ S cm}^2\text{mol}^{-1}$, respectively. If the conductivity of 0.001 M HA is $5 \times 10^{-5} \text{ S cm}^{-1}$, degree of dissociation of HA is :

Options :

1. 0.25

2. 0.125

3. 0.50

4. 0.75

Question Number : 58 Question Type : MCQ Option Shuffling : Yes Display Question Number : Yes Single Line Question Option : No Option Orientation : Vertical

Correct Marks : 4 Wrong Marks : 1

NaCl, HCl તથા NaA કે લિખે Λ_m° ક્રમશઃ 126.4, 425.9 તથા $100.5 \text{ S cm}^2\text{mol}^{-1}$ હેં. યદિ 0.001 M HA કી ચાલકતા $5 \times 10^{-5} \text{ S cm}^{-1}$ હો તો HA કી વિયોજન માત્રા હેં :

Options :

1. 0.25
2. 0.125
3. 0.50
4. 0.75

Question Number : 58 Question Type : MCQ Option Shuffling : Yes Display Question Number : Yes Single Line Question Option : No Option Orientation : Vertical

Correct Marks : 4 Wrong Marks : 1

NaCl, HCl અને NaA ની માટે \wedge_m° અનુક્રમે 126.4, 425.9 અને $100.5 \text{ S cm}^2\text{mol}^{-1}$ છે. જો 0.001 M HA ની વાહકતા $5 \times 10^{-5} \text{ S cm}^{-1}$ હોય તો HA નો વિયોજન અંક શોધો?

Options :

1. 0.25
2. 0.125
3. 0.50
4. 0.75

Question Number : 59 Question Type : MCQ Option Shuffling : Yes Display Question Number : Yes Single Line Question Option : No Option Orientation : Vertical

Correct Marks : 4 Wrong Marks : 1

For a reaction, consider the plot of $\ln k$ versus $1/T$ given in the figure. If the rate constant of this reaction at 400 K is 10^{-5} s^{-1} , then the rate constant at 500 K is :

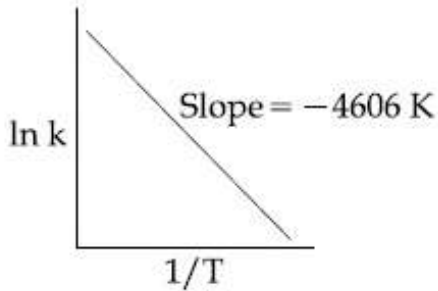

Options :

1. 10^{-4} s^{-1}
2. 10^{-6} s^{-1}

3. $2 \times 10^{-4} \text{ s}^{-1}$

4. $4 \times 10^{-4} \text{ s}^{-1}$

Question Number : 59 Question Type : MCQ Option Shuffling : Yes Display Question Number : Yes Single Line Question Option : No Option Orientation : Vertical

Correct Marks : 4 Wrong Marks : 1

एक अभिक्रिया के लिए दिये गये चित्र में $\ln k$ vs $1/T$ के प्लॉट पर विचार कीजिए। यदि इस अभिक्रिया का दर नियतांक 400 K पर 10^{-5} s^{-1} है, तो 500 K पर उसका दर नियतांक है :

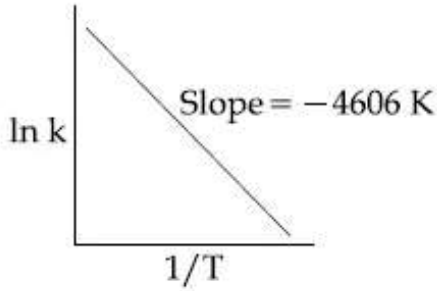

Options :

1. 10^{-4} s^{-1}

2. 10^{-6} s^{-1}

3. $2 \times 10^{-4} \text{ s}^{-1}$

4. $4 \times 10^{-4} \text{ s}^{-1}$

Question Number : 59 Question Type : MCQ Option Shuffling : Yes Display Question Number : Yes Single Line Question Option : No Option Orientation : Vertical

Correct Marks : 4 Wrong Marks : 1

एक प्रक्रिया को $\ln k$ विरुद्ध $1/T$ को आलेख ध्यान में लो जो 400 K से आ प्रक्रिया को वेग अचलांक 10^{-5} s^{-1} होय, तो 500 K से वेग अचलांक केटलो हसे?

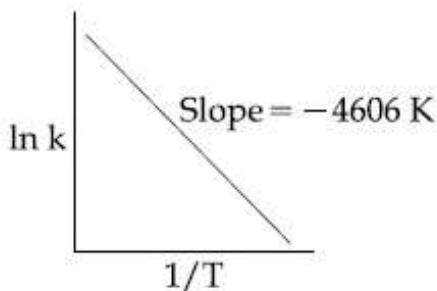

Options :

1. 10^{-4} s^{-1}

2. 10^{-6} s^{-1}
3. $2 \times 10^{-4} \text{ s}^{-1}$
4. $4 \times 10^{-4} \text{ s}^{-1}$

Question Number : 60 Question Type : MCQ Option Shuffling : Yes Display Question Number : Yes Single Line Question Option : No Option Orientation : Vertical

Correct Marks : 4 Wrong Marks : 1

Among the following, the false statement is :

Options :

1. Tyndall effect can be used to distinguish between a colloidal solution and a true solution.
2. Latex is a colloidal solution of rubber particles which are positively charged
3. It is possible to cause artificial rain by throwing electrified sand carrying charge opposite to the one on clouds from an aeroplane.
4. Lyophilic sol can be coagulated by adding an electrolyte.

Question Number : 60 Question Type : MCQ Option Shuffling : Yes Display Question Number : Yes Single Line Question Option : No Option Orientation : Vertical

Correct Marks : 4 Wrong Marks : 1

निम्नलिखित में से, असत्य कथन है :

Options :

1. टिन्डल प्रभाव का उपयोग एक कोलॉइडी विलयन तथा वास्तविक विलयन में अंतर करने के लिए किया जा सकता है।
2. लेटेक्स, रबर के कणों का एक कोलॉइडी विलयन है, जो धनावेशित होते हैं।
3. वायुयान की सहायता से बादलों पर उपस्थित आवेश से विपरीत आवेशित रेत के कणों को फेंक कर कृत्रिम वर्षा करवाना संभव है।

द्वारागी सॉल का स्कन्दन एक विद्युत अपघट्य
मिलाकर किया जा सकता है।

4.

Question Number : 60 Question Type : MCQ Option Shuffling : Yes Display Question Number : Yes Single Line Question Option :
No Option Orientation : Vertical

Correct Marks : 4 Wrong Marks : 1

नीचे आपेला पैकी क्यु विधान ओटु छे ?

Options :

1. टिन्डल असरनुं उपयोग कलिली द्रावणो अने वास्तविक द्रावणोनी वच्ये भेद पारभव्या माटे थाय छे.
2. लेटेक्स, रब्बर ना कणोनुं कलिली द्रावण छे जे धनभारीत होय छे.
3. वायुयाननी मद्द वडे वाहनो पर रहेला भारथी विज्ञेध भार धरावती भारीत रेतीने डेकीने कृत्रिम परसाह कराववो संभव छे.
4. लायोडिलिक सोलनुं स्कंदन विद्युत विभाजन्यने उभेरो करी करी शक्य.

Mathematics

Section Id :	416529156
Section Number :	3
Section type :	Online
Mandatory or Optional:	Mandatory
Number of Questions:	30
Number of Questions to be attempted:	30
Section Marks:	120
Display Number Panel:	Yes
Group All Questions:	No

Sub-Section Number:	1
Sub-Section Id:	416529165
Question Shuffling Allowed :	Yes

Question Number : 61 Question Type : MCQ Option Shuffling : Yes Display Question Number : Yes Single Line Question Option :
No Option Orientation : Vertical

Correct Marks : 4 Wrong Marks : 1

Let Z be the set of integers. If $A = \{x \in Z : 2(x+2)(x^2 - 5x + 6) = 1\}$ and $B = \{x \in Z : -3 < 2x - 1 < 9\}$, then the number of subsets of the set $A \times B$, is :

Options :

1. 2^{10}
2. 2^{12}
3. 2^{15}
4. 2^{18}

Question Number : 61 Question Type : MCQ Option Shuffling : Yes Display Question Number : Yes Single Line Question Option : No Option Orientation : Vertical

Correct Marks : 4 Wrong Marks : 1

માના Z પૂર્ણાંકોં કા સમુચ્ચય હૈ। યદિ
 $A = \{x \in Z : 2(x+2)(x^2 - 5x + 6) = 1\}$ તથા
 $B = \{x \in Z : -3 < 2x - 1 < 9\}$, તો $A \times B$ કે
ઉપસમુચ્ચયોં કી સંખ્યા હૈ :

Options :

1. 2^{10}
2. 2^{12}
3. 2^{15}
4. 2^{18}

Question Number : 61 Question Type : MCQ Option Shuffling : Yes Display Question Number : Yes Single Line Question Option : No Option Orientation : Vertical

Correct Marks : 4 Wrong Marks : 1

ધારોકે Z એ પૂર્ણાંક સંખ્યાઓનો ગણ છે.
જો $A = \{x \in Z : 2(x+2)(x^2 - 5x + 6) = 1\}$ અને
 $B = \{x \in Z : -3 < 2x - 1 < 9\}$, તો ગણ $A \times B$ ની
ઉપગણોની સંખ્યા _____ છે.

Options :

1. 2^{10}
2. 2^{12}
3. 2^{15}

4. 2^{18}

Question Number : 62 Question Type : MCQ Option Shuffling : Yes Display Question Number : Yes Single Line Question Option : No Option Orientation : Vertical

Correct Marks : 4 Wrong Marks : 1

The number of integral values of m for which the quadratic expression, $(1 + 2m)x^2 - 2(1 + 3m)x + 4(1 + m)$, $x \in \mathbb{R}$, is always positive, is :

Options :

1. 8
2. 7
3. 6
4. 3

Question Number : 62 Question Type : MCQ Option Shuffling : Yes Display Question Number : Yes Single Line Question Option : No Option Orientation : Vertical

Correct Marks : 4 Wrong Marks : 1

m के उन पूर्णांक मानों, जिनके लिए द्विपद व्यंजक $(1 + 2m)x^2 - 2(1 + 3m)x + 4(1 + m)$, $x \in \mathbb{R}$, सदा धनात्मक है, की संख्या है :

Options :

1. 8
2. 7
3. 6
4. 3

Question Number : 62 Question Type : MCQ Option Shuffling : Yes Display Question Number : Yes Single Line Question Option : No Option Orientation : Vertical

Correct Marks : 4 Wrong Marks : 1

m नी केटली पूर्णांक किंमतो भाटे द्विघात निरूपण $(1 + 2m)x^2 - 2(1 + 3m)x + 4(1 + m)$, $x \in \mathbb{R}$ हमेशा धन थाय?

Options :

1. 8

2. 7

3. 6

4. 3

Question Number : 63 Question Type : MCQ Option Shuffling : Yes Display Question Number : Yes Single Line Question Option : No Option Orientation : Vertical

Correct Marks : 4 Wrong Marks : 1

Let z_1 and z_2 be two complex numbers satisfying $|z_1|=9$ and $|z_2-3-4i|=4$. Then the minimum value of $|z_1-z_2|$ is :

Options :

1. 0

2. 1

3. $\sqrt{2}$

4. 2

Question Number : 63 Question Type : MCQ Option Shuffling : Yes Display Question Number : Yes Single Line Question Option : No Option Orientation : Vertical

Correct Marks : 4 Wrong Marks : 1

माना z_1 तथा z_2 दो सम्मिश्र संख्यायें हैं, जो $|z_1|=9$ तथा $|z_2-3-4i|=4$ को सन्तुष्ट करती है, तो $|z_1-z_2|$ का न्यूनतम मान है :

Options :

1. 0

2. 1

3. $\sqrt{2}$

4. 2

Question Number : 63 Question Type : MCQ Option Shuffling : Yes Display Question Number : Yes Single Line Question Option : No Option Orientation : Vertical

Correct Marks : 4 Wrong Marks : 1

ધારોકે બે સંકર સંખ્યાઓ z_1 અને z_2 માટે $|z_1|=9$ અને $|z_2-3-4i|=4$ છે. તો $|z_1-z_2|$ ની ન્યૂનતમ કિંમત _____ છે.

Options :

1. 0
2. 1
3. $\sqrt{2}$
4. 2

Question Number : 64 Question Type : MCQ Option Shuffling : Yes Display Question Number : Yes Single Line Question Option : No Option Orientation : Vertical

Correct Marks : 4 Wrong Marks : 1

If $A = \begin{bmatrix} 1 & \sin\theta & 1 \\ -\sin\theta & 1 & \sin\theta \\ -1 & -\sin\theta & 1 \end{bmatrix}$; then for all

$\theta \in \left(\frac{3\pi}{4}, \frac{5\pi}{4}\right)$, $\det(A)$ lies in the interval :

Options :

1. $\left(0, \frac{3}{2}\right]$
2. $\left(1, \frac{5}{2}\right]$
3. $\left(\frac{3}{2}, 3\right]$
4. $\left[\frac{5}{2}, 4\right)$

Question Number : 64 Question Type : MCQ Option Shuffling : Yes Display Question Number : Yes Single Line Question Option : No Option Orientation : Vertical

Correct Marks : 4 Wrong Marks : 1

यदि $A = \begin{bmatrix} 1 & \sin\theta & 1 \\ -\sin\theta & 1 & \sin\theta \\ -1 & -\sin\theta & 1 \end{bmatrix}$; तो सभी

$\theta \in \left(\frac{3\pi}{4}, \frac{5\pi}{4}\right)$ के लिए, $\det(A)$ निम्न में से किस

अंतराल में स्थित है?

Options :

1. $\left(0, \frac{3}{2}\right]$

2. $\left(1, \frac{5}{2}\right]$

3. $\left(\frac{3}{2}, 3\right]$

4. $\left[\frac{5}{2}, 4\right)$

Question Number : 64 Question Type : MCQ Option Shuffling : Yes Display Question Number : Yes Single Line Question Option : No Option Orientation : Vertical

Correct Marks : 4 Wrong Marks : 1

જો $A = \begin{bmatrix} 1 & \sin\theta & 1 \\ -\sin\theta & 1 & \sin\theta \\ -1 & -\sin\theta & 1 \end{bmatrix}$; હોય, તો

પ્રત્યેક $\theta \in \left(\frac{3\pi}{4}, \frac{5\pi}{4}\right)$ માટે $\det(A)$ કયા અંતરાલ માં છે?

Options :

1. $\left(0, \frac{3}{2}\right]$

2. $\left(1, \frac{5}{2}\right]$

3. $\left(\frac{3}{2}, 3\right]$

4. $\left[\frac{5}{2}, 4\right)$

Question Number : 65 Question Type : MCQ Option Shuffling : Yes Display Question Number : Yes Single Line Question Option : No Option Orientation : Vertical

Correct Marks : 4 Wrong Marks : 1

The set of all values of λ for which the system of linear equations

$$x - 2y - 2z = \lambda x$$

$$x + 2y + z = \lambda y$$

$$-x - y = \lambda z$$

has a non-trivial solution :

Options :

1. is a singleton
2. is an empty set
3. contains exactly two elements
4. contains more than two elements

Question Number : 65 Question Type : MCQ Option Shuffling : Yes Display Question Number : Yes Single Line Question Option : No Option Orientation : Vertical

Correct Marks : 4 Wrong Marks : 1

λ के उन सभी मानों, जिनके लिए रेखिक समीकरण निकाय

$$x - 2y - 2z = \lambda x$$

$$x + 2y + z = \lambda y$$

$$-x - y = \lambda z$$

का एक अतुच्छ (non-trivial) हल है :

Options :

1. का समुच्चय एकल है।
2. का समुच्चय रिक्त है।
3. के समुच्चय में मात्र दो अवयव हैं।
4. के समुच्चय में दो से अधिक अवयव हैं।

Question Number : 65 Question Type : MCQ Option Shuffling : Yes Display Question Number : Yes Single Line Question Option : No Option Orientation : Vertical

Correct Marks : 4 Wrong Marks : 1

સુરેખ સમીકરણ સંહતિ

$$x - 2y - 2z = \lambda x$$

$$x + 2y + z = \lambda y$$

$$-x - y = \lambda z$$

ને યોગ્ય ઉકેલ (non-trivial solution) હોય તેવી λ

ની તમામ કિંમતોનો ગણ એ :

Options :

1. એકકી ગણ છે.
2. ખાલી ગણ છે.
3. બરાબર બે જ સભ્યો વાળો ગણ છે.
4. બે ની વધુ સભ્યો વાળો ગણ છે.

Question Number : 66 Question Type : MCQ Option Shuffling : Yes Display Question Number : Yes Single Line Question Option : No Option Orientation : Vertical

Correct Marks : 4 Wrong Marks : 1

There are m men and two women participating in a chess tournament. Each participant plays two games with every other participant. If the number of games played by the men between themselves exceeds the number of games played between the men and the women by 84, then the value of m is :

Options :

1. 7
2. 9
3. 11
4. 12

Question Number : 66 Question Type : MCQ Option Shuffling : Yes Display Question Number : Yes Single Line Question Option : No Option Orientation : Vertical

Correct Marks : 4 Wrong Marks : 1

एक शतरंज प्रतियोगिता में m पुरुष तथा दो महिलाएं भाग ले रही हैं। प्रत्येक भागी (participant) दूसरे प्रत्येक भागी के साथ दो गेम (games) खेलता है। यदि पुरुषों के बीच आपस में खेले गये गेमों की संख्या, पुरुषों तथा महिलाओं के बीच खेले गये गेमों की संख्या से 84 अधिक हैं, तो m का मान है :

Options :

1. 7
2. 9
3. 11
4. 12

Question Number : 66 Question Type : MCQ Option Shuffling : Yes Display Question Number : Yes Single Line Question Option : No Option Orientation : Vertical

Correct Marks : 4 Wrong Marks : 1

એસની એક સ્પર્ધામાં m પુરૂષો અને બે સ્ત્રીઓ ભાગ લે છે. પ્રત્યેક સ્પર્ધક બીજા દરેક સ્પર્ધક સાથે બે રમતો રમે છે. જો પુરૂષો વચ્ચે રમાયેલ રમતોની સંખ્યા એ પુરૂષો અને સ્ત્રીઓ વચ્ચે રમાયેલ રમતોની સંખ્યા કરતાં 84 જેટલી વધુ હોય, તો m ની કિંમત _____ છે.

Options :

1. 7
2. 9
3. 11
4. 12

Question Number : 67 Question Type : MCQ Option Shuffling : Yes Display Question Number : Yes Single Line Question Option : No Option Orientation : Vertical

Correct Marks : 4 Wrong Marks : 1

The total number of irrational terms in the binomial expansion of $\left(7^{1/5} - 3^{1/10}\right)^{60}$ is :

Options :

1. 48

2. 49
3. 54
4. 55

Question Number : 67 Question Type : MCQ Option Shuffling : Yes Display Question Number : Yes Single Line Question Option : No Option Orientation : Vertical
Correct Marks : 4 Wrong Marks : 1

$\left(7^{1/5} - 3^{1/10}\right)^{60}$ के द्विपद प्रसार में अपरिमेय पदों

की कुल संख्या है :

Options :

1. 48
2. 49
3. 54
4. 55

Question Number : 67 Question Type : MCQ Option Shuffling : Yes Display Question Number : Yes Single Line Question Option : No Option Orientation : Vertical
Correct Marks : 4 Wrong Marks : 1

$\left(7^{1/5} - 3^{1/10}\right)^{60}$ ना द्विपदी विस्तारणमां असंभेय

पदोनी कुल संख्या _____ छे.

Options :

1. 48
2. 49
3. 54
4. 55

Question Number : 68 Question Type : MCQ Option Shuffling : Yes Display Question Number : Yes Single Line Question Option : No Option Orientation : Vertical
Correct Marks : 4 Wrong Marks : 1

If nC_4 , nC_5 and nC_6 are in A.P., then n can be :

Options :

1. 9
2. 11
3. 12
4. 14

Question Number : 68 Question Type : MCQ Option Shuffling : Yes Display Question Number : Yes Single Line Question Option : No Option Orientation : Vertical

Correct Marks : 4 Wrong Marks : 1

यदि nC_4 , nC_5 तथा nC_6 समान्तर श्रेणी में हैं, तो n हो सकता है :

Options :

1. 9
2. 11
3. 12
4. 14

Question Number : 68 Question Type : MCQ Option Shuffling : Yes Display Question Number : Yes Single Line Question Option : No Option Orientation : Vertical

Correct Marks : 4 Wrong Marks : 1

જો nC_4 , nC_5 અને nC_6 સમાંતર શ્રેણી (A.P.) માં હોય, તો n ની કિંમત શું હોઈ શકે ?

Options :

1. 9
2. 11
3. 12
4. 14

Question Number : 69 Question Type : MCQ Option Shuffling : Yes Display Question Number : Yes Single Line Question Option : No Option Orientation : Vertical

Correct Marks : 4 Wrong Marks : 1

यदि श्रेणी

$$\left(\frac{3}{4}\right)^3 + \left(1\frac{1}{2}\right)^3 + \left(2\frac{1}{4}\right)^3 + 3^3 + \left(3\frac{3}{4}\right)^3 + \dots$$

के प्रथम 15 पदों का योग $225k$ के बराबर है, तो k बराबर है :

Options :

1. 9
2. 27
3. 54
4. 108

Question Number : 69 Question Type : MCQ Option Shuffling : Yes Display Question Number : Yes Single Line Question Option : No Option Orientation : Vertical

Correct Marks : 4 Wrong Marks : 1

જો શ્રેણી

$$\left(\frac{3}{4}\right)^3 + \left(1\frac{1}{2}\right)^3 + \left(2\frac{1}{4}\right)^3 + 3^3 + \left(3\frac{3}{4}\right)^3 + \dots$$

ના પ્રથમ 15 પદોનો સરવાળો $225k$ હોય, તો

$k = \underline{\hspace{2cm}}$.

Options :

1. 9
2. 27
3. 54
4. 108

Question Number : 69 Question Type : MCQ Option Shuffling : Yes Display Question Number : Yes Single Line Question Option : No Option Orientation : Vertical

Correct Marks : 4 Wrong Marks : 1

If the sum of the first 15 terms of the series

$$\left(\frac{3}{4}\right)^3 + \left(1\frac{1}{2}\right)^3 + \left(2\frac{1}{4}\right)^3 + 3^3 + \left(3\frac{3}{4}\right)^3 + \dots$$

is equal to $225k$, then k is equal to :

Options :

1. 9

2. 27
3. 54
4. 108

Question Number : 70 Question Type : MCQ Option Shuffling : Yes Display Question Number : Yes Single Line Question Option : No Option Orientation : Vertical

Correct Marks : 4 Wrong Marks : 1

$$\lim_{x \rightarrow 1^-} \frac{\sqrt{\pi} - \sqrt{2 \sin^{-1} x}}{\sqrt{1-x}} \text{ is equal to :}$$

Options :

1. $\sqrt{\frac{2}{\pi}}$
2. $\sqrt{\frac{\pi}{2}}$
3. $\frac{1}{\sqrt{2\pi}}$
4. $\sqrt{\pi}$

Question Number : 70 Question Type : MCQ Option Shuffling : Yes Display Question Number : Yes Single Line Question Option : No Option Orientation : Vertical

Correct Marks : 4 Wrong Marks : 1

$$\lim_{x \rightarrow 1^-} \frac{\sqrt{\pi} - \sqrt{2 \sin^{-1} x}}{\sqrt{1-x}} \text{ बराबर है :}$$

Options :

1. $\sqrt{\frac{2}{\pi}}$
2. $\sqrt{\frac{\pi}{2}}$
3. $\frac{1}{\sqrt{2\pi}}$

$$\sqrt{\pi}$$

4.

Question Number : 70 Question Type : MCQ Option Shuffling : Yes Display Question Number : Yes Single Line Question Option : No Option Orientation : Vertical

Correct Marks : 4 Wrong Marks : 1

$$\lim_{x \rightarrow 1^-} \frac{\sqrt{\pi} - \sqrt{2\sin^{-1} x}}{\sqrt{1-x}} = \dots\dots\dots$$

Options :

1. $\sqrt{\frac{2}{\pi}}$

2. $\sqrt{\frac{\pi}{2}}$

3. $\frac{1}{\sqrt{2\pi}}$

4. $\sqrt{\pi}$

Question Number : 71 Question Type : MCQ Option Shuffling : Yes Display Question Number : Yes Single Line Question Option : No Option Orientation : Vertical

Correct Marks : 4 Wrong Marks : 1

Let f be a differentiable function such that $f(1) = 2$ and $f'(x) = f(x)$ for all $x \in \mathbb{R}$. If $h(x) = f(f(x))$, then $h'(1)$ is equal to :

Options :

1. $2e^2$

2. $4e$

3. $2e$

4. $4e^2$

Question Number : 71 Question Type : MCQ Option Shuffling : Yes Display Question Number : Yes Single Line Question Option : No Option Orientation : Vertical

Correct Marks : 4 Wrong Marks : 1

माना f एक अवकलनीय फलन इस प्रकार है कि $f(1) = 2$
तथा सभी $x \in \mathbb{R}$ के लिए $f'(x) = f(x)$. यदि
 $h(x) = f(f(x))$, तो $h'(1)$ बराबर है :

Options :

1. $2e^2$
2. $4e$
3. $2e$
4. $4e^2$

Question Number : 71 Question Type : MCQ Option Shuffling : Yes Display Question Number : Yes Single Line Question Option : No Option Orientation : Vertical

Correct Marks : 4 Wrong Marks : 1

ધારોકે f એ એવું વિકલનીય વિધેય છે કે જેથી $f(1) = 2$
અને પ્રત્યેક $x \in \mathbb{R}$ માટે $f'(x) = f(x)$ થાય. જો
 $h(x) = f(f(x))$ હોય, તો $h'(1) = \underline{\hspace{2cm}}$.

Options :

1. $2e^2$
2. $4e$
3. $2e$
4. $4e^2$

Question Number : 72 Question Type : MCQ Option Shuffling : Yes Display Question Number : Yes Single Line Question Option : No Option Orientation : Vertical

Correct Marks : 4 Wrong Marks : 1

The tangent to the curve $y = x^2 - 5x + 5$,
parallel to the line $2y = 4x + 1$, also passes
through the point :

Options :

1. $\left(\frac{7}{2}, \frac{1}{4}\right)$
2. $\left(\frac{1}{4}, \frac{7}{2}\right)$

3. $\left(-\frac{1}{8}, 7\right)$

4. $\left(\frac{1}{8}, -7\right)$

Question Number : 72 Question Type : MCQ Option Shuffling : Yes Display Question Number : Yes Single Line Question Option : No Option Orientation : Vertical

Correct Marks : 4 Wrong Marks : 1

वक्र $y = x^2 - 5x + 5$ की स्पर्श रेखा, जो रेखा $2y = 4x + 1$ के समान्तर है, निम्न में से किस बिन्दु से होकर जाती है?

Options :

1. $\left(\frac{7}{2}, \frac{1}{4}\right)$

2. $\left(\frac{1}{4}, \frac{7}{2}\right)$

3. $\left(-\frac{1}{8}, 7\right)$

4. $\left(\frac{1}{8}, -7\right)$

Question Number : 72 Question Type : MCQ Option Shuffling : Yes Display Question Number : Yes Single Line Question Option : No Option Orientation : Vertical

Correct Marks : 4 Wrong Marks : 1

रेखा $2y = 4x + 1$ ने समांतर होय लेवी, वक्र $y = x^2 - 5x + 5$ नी स्पर्श रेखा _____ बिंदुमांथी पण पसार थाय छे.

Options :

1. $\left(\frac{7}{2}, \frac{1}{4}\right)$

2. $\left(\frac{1}{4}, \frac{7}{2}\right)$

3. $\left(-\frac{1}{8}, 7\right)$

4. $\left(\frac{1}{8}, -7\right)$

Question Number : 73 Question Type : MCQ Option Shuffling : Yes Display Question Number : Yes Single Line Question Option : No Option Orientation : Vertical

Correct Marks : 4 Wrong Marks : 1

If the function f given by

$f(x) = x^3 - 3(a-2)x^2 + 3ax + 7$, for some $a \in \mathbb{R}$ is increasing in $(0, 1]$ and decreasing in $[1, 5)$, then a root of the equation,

$$\frac{f(x) - 14}{(x - 1)^2} = 0 \quad (x \neq 1) \text{ is :}$$

Options :

1. -7

2. 5

3. 6

4. 7

Question Number : 73 Question Type : MCQ Option Shuffling : Yes Display Question Number : Yes Single Line Question Option : No Option Orientation : Vertical

Correct Marks : 4 Wrong Marks : 1

यदि फलन $f(x) = x^3 - 3(a-2)x^2 + 3ax + 7$, किसी $a \in \mathbb{R}$ के लिए, $(0, 1]$ में वर्धमान है तथा $[1, 5)$ में ह्रासमान

है, तो समीकरण $\frac{f(x) - 14}{(x - 1)^2} = 0 \quad (x \neq 1)$ का एक

हल है :

Options :

1. -7

2. 5

3. 6

4. 7

Question Number : 73 Question Type : MCQ Option Shuffling : Yes Display Question Number : Yes Single Line Question Option : No Option Orientation : Vertical

Correct Marks : 4 Wrong Marks : 1

જો $f(x) = x^3 - 3(a-2)x^2 + 3ax + 7$ દ્વારા વ્યાખ્યાયિત વિધેય એ $(0, 1]$ માં વધતું અને $[1, 5)$ માં ઘટતું વિધેય હોય, તો સમીકરણ

$$\frac{f(x) - 14}{(x-1)^2} = 0 \quad (x \neq 1) \text{ નું એક બીજ } \underline{\hspace{2cm}}$$

છે.

Options :

1. -7
2. 5
3. 6
4. 7

Question Number : 74 Question Type : MCQ Option Shuffling : Yes Display Question Number : Yes Single Line Question Option : No Option Orientation : Vertical

Correct Marks : 4 Wrong Marks : 1

The integral $\int \frac{3x^{13} + 2x^{11}}{(2x^4 + 3x^2 + 1)^4} dx$ is

equal to :

(where C is a constant of integration)

Options :

1. $\frac{x^4}{6(2x^4 + 3x^2 + 1)^3} + C$
2. $\frac{x^{12}}{6(2x^4 + 3x^2 + 1)^3} + C$
3. $\frac{x^4}{(2x^4 + 3x^2 + 1)^3} + C$

$$\frac{x^{12}}{(2x^4 + 3x^2 + 1)^3} + C$$

4.

Question Number : 74 Question Type : MCQ Option Shuffling : Yes Display Question Number : Yes Single Line Question Option : No Option Orientation : Vertical

Correct Marks : 4 Wrong Marks : 1

समाकल $\int \frac{3x^{13} + 2x^{11}}{(2x^4 + 3x^2 + 1)^4} dx$ बराबर है :

(जहाँ C समाकलन का एक अचर है)

Options :

$$\frac{x^4}{6(2x^4 + 3x^2 + 1)^3} + C$$

1.

$$\frac{x^{12}}{6(2x^4 + 3x^2 + 1)^3} + C$$

2.

$$\frac{x^4}{(2x^4 + 3x^2 + 1)^3} + C$$

3.

$$\frac{x^{12}}{(2x^4 + 3x^2 + 1)^3} + C$$

4.

Question Number : 74 Question Type : MCQ Option Shuffling : Yes Display Question Number : Yes Single Line Question Option : No Option Orientation : Vertical

Correct Marks : 4 Wrong Marks : 1

संकलित $\int \frac{3x^{13} + 2x^{11}}{(2x^4 + 3x^2 + 1)^4} dx = \underline{\hspace{2cm}}$.

(ज्यां C એ સંકલનનો અચળાંક છે.)

Options :

$$\frac{x^4}{6(2x^4 + 3x^2 + 1)^3} + C$$

1.

2. $\frac{x^{12}}{6(2x^4 + 3x^2 + 1)^3} + C$

3. $\frac{x^4}{(2x^4 + 3x^2 + 1)^3} + C$

4. $\frac{x^{12}}{(2x^4 + 3x^2 + 1)^3} + C$

Question Number : 75 Question Type : MCQ Option Shuffling : Yes Display Question Number : Yes Single Line Question Option : No Option Orientation : Vertical

Correct Marks : 4 Wrong Marks : 1

The integral $\int_1^e \left\{ \left(\frac{x}{e} \right)^{2x} - \left(\frac{e}{x} \right)^x \right\} \log_e x \, dx$

is equal to :

Options :

1. $\frac{3}{2} - \frac{1}{e} - \frac{1}{2e^2}$

2. $\frac{3}{2} - e - \frac{1}{2e^2}$

3. $-\frac{1}{2} + \frac{1}{e} - \frac{1}{2e^2}$

4. $\frac{1}{2} - e - \frac{1}{e^2}$

Question Number : 75 Question Type : MCQ Option Shuffling : Yes Display Question Number : Yes Single Line Question Option : No Option Orientation : Vertical

Correct Marks : 4 Wrong Marks : 1

समाकल $\int_1^e \left\{ \left(\frac{x}{e} \right)^{2x} - \left(\frac{e}{x} \right)^x \right\} \log_e x \, dx$

बराबर है :

Options :

1. $\frac{3}{2} - \frac{1}{e} - \frac{1}{2e^2}$

2. $\frac{3}{2} - e - \frac{1}{2e^2}$

3. $-\frac{1}{2} + \frac{1}{e} - \frac{1}{2e^2}$

4. $\frac{1}{2} - e - \frac{1}{e^2}$

Question Number : 75 Question Type : MCQ Option Shuffling : Yes Display Question Number : Yes Single Line Question Option : No Option Orientation : Vertical

Correct Marks : 4 Wrong Marks : 1

संकलित

$$\int_1^e \left\{ \left(\frac{x}{e} \right)^{2x} - \left(\frac{e}{x} \right)^x \right\} \log_e x \, dx = \underline{\hspace{2cm}}$$

Options :

1. $\frac{3}{2} - \frac{1}{e} - \frac{1}{2e^2}$

2. $\frac{3}{2} - e - \frac{1}{2e^2}$

3. $-\frac{1}{2} + \frac{1}{e} - \frac{1}{2e^2}$

4. $\frac{1}{2} - e - \frac{1}{e^2}$

Question Number : 76 Question Type : MCQ Option Shuffling : Yes Display Question Number : Yes Single Line Question Option : No Option Orientation : Vertical

Correct Marks : 4 Wrong Marks : 1

$$\lim_{n \rightarrow \infty} \left(\frac{n}{n^2 + 1^2} + \frac{n}{n^2 + 2^2} + \frac{n}{n^2 + 3^2} + \dots + \frac{1}{5n} \right)$$

is equal to :

Options :

1. $\tan^{-1}(2)$

2. $\tan^{-1}(3)$

3. $\frac{\pi}{4}$

4. $\frac{\pi}{2}$

Question Number : 76 Question Type : MCQ Option Shuffling : Yes Display Question Number : Yes Single Line Question Option : No Option Orientation : Vertical

Correct Marks : 4 Wrong Marks : 1

$$\lim_{n \rightarrow \infty} \left(\frac{n}{n^2 + 1^2} + \frac{n}{n^2 + 2^2} + \frac{n}{n^2 + 3^2} + \dots + \frac{1}{5n} \right)$$

बराबर है :

Options :

1. $\tan^{-1}(2)$

2. $\tan^{-1}(3)$

3. $\frac{\pi}{4}$

4. $\frac{\pi}{2}$

Question Number : 76 Question Type : MCQ Option Shuffling : Yes Display Question Number : Yes Single Line Question Option : No Option Orientation : Vertical

Correct Marks : 4 Wrong Marks : 1

$$\lim_{n \rightarrow \infty} \left(\frac{n}{n^2 + 1^2} + \frac{n}{n^2 + 2^2} + \frac{n}{n^2 + 3^2} + \dots + \frac{1}{5n} \right) =$$

Options :

1. $\tan^{-1}(2)$

2. $\tan^{-1}(3)$

3. $\frac{\pi}{4}$

4. $\frac{\pi}{2}$

Question Number : 77 Question Type : MCQ Option Shuffling : Yes Display Question Number : Yes Single Line Question Option : No Option Orientation : Vertical

Correct Marks : 4 Wrong Marks : 1

If a curve passes through the point $(1, -2)$ and has slope of the tangent at any point

(x, y) on it as $\frac{x^2 - 2y}{x}$, then the curve also

passes through the point :

Options :

1. $(3, 0)$
2. $(-1, 2)$
3. $(-\sqrt{2}, 1)$
4. $(\sqrt{3}, 0)$

Question Number : 77 Question Type : MCQ Option Shuffling : Yes Display Question Number : Yes Single Line Question Option : No Option Orientation : Vertical

Correct Marks : 4 Wrong Marks : 1

यदि एक वक्र बिन्दु $(1, -2)$ से होकर जाता है तथा इस पर किसी बिन्दु (x, y) पर स्पर्श रेखा का ढाल (slope)

$\frac{x^2 - 2y}{x}$ है, तो यह वक्र निम्न में से किस बिन्दु से

होकर जाता है?

Options :

1. $(3, 0)$
2. $(-1, 2)$
3. $(-\sqrt{2}, 1)$
4. $(\sqrt{3}, 0)$

Question Number : 77 Question Type : MCQ Option Shuffling : Yes Display Question Number : Yes Single Line Question Option : No Option Orientation : Vertical

Correct Marks : 4 Wrong Marks : 1

જો બિંદુ $(1, -2)$ માંથી પસાર થતા એક વક્ર પરના કોઈ

પણ બિંદુ (x, y) આગળ તેના સ્પર્શકનો ઢાળ $\frac{x^2 - 2y}{x}$

હોય, તો તે વક્ર _____ બિંદુ માંથી પણ પસાર થાય છે.

Options :

1. $(3, 0)$

2. $(-1, 2)$

3. $(-\sqrt{2}, 1)$

4. $(\sqrt{3}, 0)$

Question Number : 78 Question Type : MCQ Option Shuffling : Yes Display Question Number : Yes Single Line Question Option : No Option Orientation : Vertical

Correct Marks : 4 Wrong Marks : 1

If a straight line passing through the point $P(-3, 4)$ is such that its intercepted portion between the coordinate axes is bisected at P , then its equation is :

Options :

1. $4x + 3y = 0$

2. $x - y + 7 = 0$

3. $3x - 4y + 25 = 0$

4. $4x - 3y + 24 = 0$

Question Number : 78 Question Type : MCQ Option Shuffling : Yes Display Question Number : Yes Single Line Question Option : No Option Orientation : Vertical

Correct Marks : 4 Wrong Marks : 1

યદિ બિન્દુ $P(-3, 4)$ સે હોકર જાને વાલી એક સરલ રેખા ઇસ પ્રકાર હૈ કિ ઇસકા નિર્દેશાંક અક્ષોં કે બીચ અંતઃખણ્ડિત ભાગ કા મધ્ય બિન્દુ P હૈ, તો ઇસકા સમીકરણ હૈ :

Options :

1. $4x + 3y = 0$

2. $x - y + 7 = 0$

3. $3x - 4y + 25 = 0$

4. $4x - 3y + 24 = 0$

Question Number : 78 Question Type : MCQ Option Shuffling : Yes Display Question Number : Yes Single Line Question Option : No Option Orientation : Vertical

Correct Marks : 4 Wrong Marks : 1

બિંદુ $P(-3, 4)$ માંથી પસાર થતી રેખાનો, યામાક્ષો વચ્ચે અંતરાયેલ ભાગ એ બિંદુ P આગળ દુભાગાય છે. તો આ રેખાનું સમીકરણ _____ છે.

Options :

1. $4x + 3y = 0$

2. $x - y + 7 = 0$

3. $3x - 4y + 25 = 0$

4. $4x - 3y + 24 = 0$

Question Number : 79 Question Type : MCQ Option Shuffling : Yes Display Question Number : Yes Single Line Question Option : No Option Orientation : Vertical

Correct Marks : 4 Wrong Marks : 1

If a circle of radius R passes through the origin O and intersects the coordinate axes at A and B , then the locus of the foot of perpendicular from O on AB is :

Options :

1. $(x^2 + y^2)^3 = 4R^2x^2y^2$

2. $(x^2 + y^2)^2 = 4R^2x^2y^2$

3. $(x^2 + y^2)^2 = 4Rx^2y^2$

4. $(x^2 + y^2)(x + y) = R^2xy$

Question Number : 79 Question Type : MCQ Option Shuffling : Yes Display Question Number : Yes Single Line Question Option : No Option Orientation : Vertical

Correct Marks : 4 Wrong Marks : 1

यदि R त्रिज्या का एक वृत्त मूल बिन्दु O से होकर जाता है तथा निर्देशांक अक्षों को A और B पर काटता है, तो O से रेखा AB पर डाले गये लम्ब के पाद का बिन्दुपथ है :

Options :

1. $(x^2 + y^2)^3 = 4R^2x^2y^2$
2. $(x^2 + y^2)^2 = 4R^2x^2y^2$
3. $(x^2 + y^2)^2 = 4Rx^2y^2$
4. $(x^2 + y^2)(x + y) = R^2xy$

Question Number : 79 Question Type : MCQ Option Shuffling : Yes Display Question Number : Yes Single Line Question Option : No Option Orientation : Vertical

Correct Marks : 4 Wrong Marks : 1

જો R ત્રિજ્યાવાળું અને ઊગમબિંદુ O માંથી પસાર થતું એક વર્તુળ યામાક્ષોને A અને B માં છેદે તો O માંથી AB પરનાં લંબપાદ નો બિંદુપથ _____ છે.

Options :

1. $(x^2 + y^2)^3 = 4R^2x^2y^2$
2. $(x^2 + y^2)^2 = 4R^2x^2y^2$
3. $(x^2 + y^2)^2 = 4Rx^2y^2$
4. $(x^2 + y^2)(x + y) = R^2xy$

Question Number : 80 Question Type : MCQ Option Shuffling : Yes Display Question Number : Yes Single Line Question Option : No Option Orientation : Vertical

Correct Marks : 4 Wrong Marks : 1

The equation of a tangent to the parabola, $x^2 = 8y$, which makes an angle θ with the positive direction of x -axis, is :

Options :

1. $y = x \tan\theta - 2 \cot\theta$
2. $x = y \cot\theta + 2 \tan\theta$
3. $x = y \cot\theta - 2 \tan\theta$

4. $y = x \tan \theta + 2 \cot \theta$

Question Number : 80 Question Type : MCQ Option Shuffling : Yes Display Question Number : Yes Single Line Question Option : No Option Orientation : Vertical

Correct Marks : 4 Wrong Marks : 1

परवलय $x^2 = 8y$ पर एक स्पर्श रेखा, जो x -अक्ष की धनात्मक दिशा के साथ कोण θ बनाती है, का समीकरण है :

Options :

1. $y = x \tan \theta - 2 \cot \theta$
2. $x = y \cot \theta + 2 \tan \theta$
3. $x = y \cot \theta - 2 \tan \theta$
4. $y = x \tan \theta + 2 \cot \theta$

Question Number : 80 Question Type : MCQ Option Shuffling : Yes Display Question Number : Yes Single Line Question Option : No Option Orientation : Vertical

Correct Marks : 4 Wrong Marks : 1

x -अक्षની ધન દિશા સાથે θ ખૂણો બનાવતા, પરવલય $x^2 = 8y$ ના સ્પર્શકનું સમીકરણ _____ છે.

Options :

1. $y = x \tan \theta - 2 \cot \theta$
2. $x = y \cot \theta + 2 \tan \theta$
3. $x = y \cot \theta - 2 \tan \theta$
4. $y = x \tan \theta + 2 \cot \theta$

Question Number : 81 Question Type : MCQ Option Shuffling : Yes Display Question Number : Yes Single Line Question Option : No Option Orientation : Vertical

Correct Marks : 4 Wrong Marks : 1

Let S and S' be the foci of an ellipse and B be any one of the extremities of its minor axis. If $\Delta S'BS$ is a right angled triangle with right angle at B and area $(\Delta S'BS) = 8$ sq. units, then the length of a latus rectum of the ellipse is :

Options :

1. 2

2. $2\sqrt{2}$

3. $4\sqrt{2}$

4. 4

Question Number : 81 Question Type : MCQ Option Shuffling : Yes Display Question Number : Yes Single Line Question Option : No Option Orientation : Vertical

Correct Marks : 4 Wrong Marks : 1

माना एक दीर्घवृत्त की नाभियाँ S तथा S' हैं तथा इसके लघु अक्ष का कोई एक शीर्ष B है। यदि $\Delta S'BS$ एक समकोण त्रिभुज है जिसका समकोण B पर है तथा $\Delta S'BS$ का क्षेत्रफल 8 वर्ग इकाई है, तो दीर्घवृत्त की एक नाभिलम्ब जीवा की लम्बाई है :

Options :

1. 2

2. $2\sqrt{2}$

3. $4\sqrt{2}$

4. 4

Question Number : 81 Question Type : MCQ Option Shuffling : Yes Display Question Number : Yes Single Line Question Option : No Option Orientation : Vertical

Correct Marks : 4 Wrong Marks : 1

ધારો કે S અને S' એ એક ઉપવલયની નાભિઓ છે અને B એ તેના ગૌણ અક્ષનું એક અંત્યબિંદુ છે. જો કાટકોણ ત્રિકોણ $\Delta S'BS$ માં ખૂણો B કાટખૂણો હોય અને $\Delta S'BS$ નું ક્ષેત્રફળ = 8 થો. એકમ હોય તો આ ઉપવલયના નાભિલંબની લંબાઈ _____ છે.

Options :

1. 2

2. $2\sqrt{2}$

3. $4\sqrt{2}$

4. 4

Question Number : 82 Question Type : MCQ Option Shuffling : Yes Display Question Number : Yes Single Line Question Option : No Option Orientation : Vertical

Correct Marks : 4 Wrong Marks : 1

यदि रेखा $\frac{x+1}{2} = \frac{y-2}{1} = \frac{z-3}{-2}$ तथा समतल

$x-2y-kz=3$ के बीच का कोण $\cos^{-1}\left(\frac{2\sqrt{2}}{3}\right)$

है, तो k का एक मान है :

Options :

1. $\sqrt{\frac{5}{3}}$

2. $\sqrt{\frac{3}{5}}$

3. $-\frac{3}{5}$

4. $-\frac{5}{3}$

Question Number : 82 Question Type : MCQ Option Shuffling : Yes Display Question Number : Yes Single Line Question Option : No Option Orientation : Vertical

Correct Marks : 4 Wrong Marks : 1

जे रेखा $\frac{x+1}{2} = \frac{y-2}{1} = \frac{z-3}{-2}$ अने समतल

$x-2y-kz=3$ वर्येनो भूशो $\cos^{-1}\left(\frac{2\sqrt{2}}{3}\right)$ होय,

तो k नी किमत _____ छे.

Options :

1. $\sqrt{\frac{5}{3}}$

2. $\sqrt{\frac{3}{5}}$

3. $-\frac{3}{5}$

4. $-\frac{5}{3}$

Question Number : 82 Question Type : MCQ Option Shuffling : Yes Display Question Number : Yes Single Line Question Option : No Option Orientation : Vertical

Correct Marks : 4 Wrong Marks : 1

If an angle between the line,

$$\frac{x+1}{2} = \frac{y-2}{1} = \frac{z-3}{-2} \text{ and the plane,}$$

$$x-2y-kz=3 \text{ is } \cos^{-1}\left(\frac{2\sqrt{2}}{3}\right), \text{ then a value}$$

of k is :

Options :

1. $\sqrt{\frac{5}{3}}$

2. $\sqrt{\frac{3}{5}}$

3. $-\frac{3}{5}$

4. $-\frac{5}{3}$

Question Number : 83 Question Type : MCQ Option Shuffling : Yes Display Question Number : Yes Single Line Question Option : No Option Orientation : Vertical

Correct Marks : 4 Wrong Marks : 1

Let S be the set of all real values of λ such that a plane passing through the points $(-\lambda^2, 1, 1)$, $(1, -\lambda^2, 1)$ and $(1, 1, -\lambda^2)$ also passes through the point $(-1, -1, 1)$. Then S is equal to :

Options :

1. $\{\sqrt{3}\}$

2. $\{1, -1\}$

3. $\{3, -3\}$

4. $\{\sqrt{3}, -\sqrt{3}\}$

Question Number : 83 Question Type : MCQ Option Shuffling : Yes Display Question Number : Yes Single Line Question Option : No Option Orientation : Vertical

Correct Marks : 4 Wrong Marks : 1

यदि λ के उन सभी वास्तविक मानों, जिनके लिए बिन्दुओं $(-\lambda^2, 1, 1)$, $(1, -\lambda^2, 1)$ तथा $(1, 1, -\lambda^2)$ से होकर जाने वाला एक समतल, बिन्दु $(-1, -1, 1)$ से भी होकर जाता है, का समुच्चय S है, तो S बराबर है :

Options :

1. $\{\sqrt{3}\}$

2. $\{1, -1\}$

3. $\{3, -3\}$

4. $\{\sqrt{3}, -\sqrt{3}\}$

Question Number : 83 Question Type : MCQ Option Shuffling : Yes Display Question Number : Yes Single Line Question Option : No Option Orientation : Vertical

Correct Marks : 4 Wrong Marks : 1

धारे के बिंदुओं $(-\lambda^2, 1, 1)$, $(1, -\lambda^2, 1)$ અને $(1, 1, -\lambda^2)$ માંથી પસાર થતું સમતલ, એ બિંદુ $(-1, -1, 1)$ માંથી પણ પસાર થાય તેવી λ ની તમામ વાસ્તવિક કિંમતોનો ગણ S છે. તો $S = \underline{\hspace{2cm}}$.

Options :

1. $\{\sqrt{3}\}$

2. $\{1, -1\}$

3. $\{3, -3\}$

4. $\{\sqrt{3}, -\sqrt{3}\}$

Question Number : 84 Question Type : MCQ Option Shuffling : Yes Display Question Number : Yes Single Line Question Option : No Option Orientation : Vertical

Correct Marks : 4 Wrong Marks : 1

Let \vec{a} , \vec{b} and \vec{c} be three unit vectors, out of which vectors \vec{b} and \vec{c} are non-parallel.

If α and β are the angles which vector \vec{a} makes with vectors \vec{b} and \vec{c} respectively and $\vec{a} \times (\vec{b} \times \vec{c}) = \frac{1}{2} \vec{b}$, then $|\alpha - \beta|$ is equal to :

Options :

1. 60°
2. 45°
3. 30°
4. 90°

Question Number : 84 Question Type : MCQ Option Shuffling : Yes Display Question Number : Yes Single Line Question Option : No Option Orientation : Vertical

Correct Marks : 4 Wrong Marks : 1

माना \vec{a} , \vec{b} तथा \vec{c} तीन एकक सदिश हैं, जिनमें से सदिश \vec{b} तथा \vec{c} असमान्तर हैं। यदि सदिश \vec{a} , सदिशों \vec{b} तथा \vec{c} से क्रमशः कोण α तथा β बनाता है और $\vec{a} \times (\vec{b} \times \vec{c}) = \frac{1}{2} \vec{b}$, तो $|\alpha - \beta|$ बराबर

है :

Options :

1. 60°
2. 45°
3. 30°
4. 90°

Question Number : 84 Question Type : MCQ Option Shuffling : Yes Display Question Number : Yes No Option Orientation : Vertical

Correct Marks : 4 Wrong Marks : 1

ધારો કે ત્રણ એકમ સદિશો \vec{a} , \vec{b} અને \vec{c} માંથી \vec{b}

અને \vec{c} એ સમાંતર ન હોય તેવા સદિશો છે. જો સદિશ

\vec{a} એ સદિશો \vec{b} અને \vec{c} સાથે બનાવેલ ખૂણા અનુક્રમે

α અને β , તથા $\vec{a} \times (\vec{b} \times \vec{c}) = \frac{1}{2} \vec{b}$ હોય તો

$|\alpha - \beta| = \underline{\hspace{2cm}}$.

Options :

1. 60°
2. 45°
3. 30°
4. 90°

Question Number : 85 Question Type : MCQ Option Shuffling : Yes Display Question Number : Yes Single Line Question Option : No Option Orientation : Vertical

Correct Marks : 4 Wrong Marks : 1

The mean and the variance of five observations are 4 and 5.20, respectively.

If three of the observations are 3, 4 and 4 ; then the absolute value of the difference of the other two observations, is :

Options :

1. 1
2. 3
3. 5
4. 7

Question Number : 85 Question Type : MCQ Option Shuffling : Yes Display Question Number : Yes Single Line Question Option : No Option Orientation : Vertical

Correct Marks : 4 Wrong Marks : 1

पाँच प्रेक्षणों का माध्य तथा प्रसरण क्रमशः 4 तथा 5.20 हैं। यदि इन प्रेक्षणों में से तीन 3, 4 तथा 4 हैं, तो अन्य दो प्रेक्षणों के अन्तर का निरपेक्ष (absolute) मान है :

Options :

1. 1
2. 3
3. 5
4. 7

Question Number : 85 Question Type : MCQ Option Shuffling : Yes Display Question Number : Yes Single Line Question Option : No Option Orientation : Vertical

Correct Marks : 4 Wrong Marks : 1

5 અવલોકનોનો મધ્યક અને વિચરણ અનુક્રમે 4 અને 5.20 છે. જો આમાંના ત્રણ અવલોકનો 3, 4 અને 4 હોય, તો બાકીના બે અવલોકનોના તફાવતનું નિરપેક્ષ મૂલ્ય _____ છે.

Options :

1. 1
2. 3
3. 5
4. 7

Question Number : 86 Question Type : MCQ Option Shuffling : Yes Display Question Number : Yes Single Line Question Option : No Option Orientation : Vertical

Correct Marks : 4 Wrong Marks : 1

In a class of 60 students, 40 opted for NCC, 30 opted for NSS and 20 opted for both NCC and NSS. If one of these students is selected at random, then the probability that the student selected has opted neither for NCC nor for NSS is :

Options :

1. $\frac{1}{6}$
2. $\frac{2}{3}$
3. $\frac{5}{6}$

4. $\frac{1}{3}$

Question Number : 86 Question Type : MCQ Option Shuffling : Yes Display Question Number : Yes Single Line Question Option : No Option Orientation : Vertical

Correct Marks : 4 Wrong Marks : 1

60 छात्रों की एक कक्षा में, 40 ने NCC ली, 30 ने NSS ली तथा 20 ने NCC और NSS दोनों लीं। यदि इनमें से एक छात्र यादृच्छिक चुना गया है, तो चुने हुए छात्र के न तो NCC, न ही NSS लेने की प्रायिकता है :

Options :

1. $\frac{1}{6}$

2. $\frac{2}{3}$

3. $\frac{5}{6}$

4. $\frac{1}{3}$

Question Number : 86 Question Type : MCQ Option Shuffling : Yes Display Question Number : Yes Single Line Question Option : No Option Orientation : Vertical

Correct Marks : 4 Wrong Marks : 1

60 વિદ્યાર્થીઓના એક વર્ગમાંથી , 40 વિદ્યાર્થીઓએ NCC, 30 વિદ્યાર્થીઓ એ NSS અને 20 વિદ્યાર્થીઓએ NCC અને NSS બન્ને વિકલ્પો પસંદ કર્યા. જો આમાંથી કોઈ એક વિદ્યાર્થી યાદચ્છિક રીતે પસંદ કરવામાં આવે તો પસંદ થયેલ વિદ્યાર્થીએ NCC કે NSS બન્નેમાંથી કોઈપણ વિકલ્પ પસંદ ન કર્યો હોય તેની સંભાવના _____ છે.

Options :

1. $\frac{1}{6}$

2. $\frac{2}{3}$

3. $\frac{5}{6}$

4. $\frac{1}{3}$

Question Number : 87 Question Type : MCQ Option Shuffling : Yes Display Question Number : Yes Single Line Question Option : No Option Orientation : Vertical

Correct Marks : 4 Wrong Marks : 1

In a game, a man wins Rs. 100 if he gets 5 or 6 on a throw of a fair die and loses Rs. 50 for getting any other number on the die. If he decides to throw the die either till he gets a five or a six or to a maximum of three throws, then his expected gain/loss (in rupees) is :

Options :

1. $\frac{400}{9}$ loss

2. $\frac{400}{3}$ loss

3. $\frac{400}{3}$ gain

4. 0

Question Number : 87 Question Type : MCQ Option Shuffling : Yes Display Question Number : Yes Single Line Question Option : No Option Orientation : Vertical

Correct Marks : 4 Wrong Marks : 1

एक खेल में एक अनभिन्नत पासा फेंकने पर 5 या 6 आने पर एक व्यक्ति 100 रु. जीतता है तथा पासे पर कोई अन्य संख्या आने पर 50 रु. हारता है। यदि वह यह तय करता है कि वह या तब तक पासा फेंकेगा जब तक 5 या 6 न आ जाए अथवा अधिक से अधिक तीन बार पासा फेंकेगा, तो उसकी संभावित लाभ/हानि (रुपयों में) है :

Options :

1. $\frac{400}{9}$ हानि

2. $\frac{400}{3}$ હાનિ

3. $\frac{400}{3}$ લાભ

4. 0

Question Number : 87 Question Type : MCQ Option Shuffling : Yes Display Question Number : Yes Single Line Question Option : No Option Orientation : Vertical

Correct Marks : 4 Wrong Marks : 1

સમતોલ પાસો ફેંકવાની એક રમતમાં, જો પાસા પર 5 અથવા 6 મળે તો વ્યક્તિ 100 રૂ. જીતે છે અને જો આ સિવાયનો બીજો કોઈ અંક મળે તો તે 50 રૂ. હારે છે. જો તે પાંચ અથવા છ મળે ત્યાં સુધી અથવા તો મહત્તમ ત્રણ વખત પાસો ફેંકવાનું નક્કી કરે તો તેના નફા/નુકશાન (રૂપિયામાં) ની અપેક્ષિત કિંમત _____ છે.

Options :

1. $\frac{400}{9}$ નુકશાની

2. $\frac{400}{3}$ નુકશાની

3. $\frac{400}{3}$ નફો

4. 0

Question Number : 88 Question Type : MCQ Option Shuffling : Yes Display Question Number : Yes Single Line Question Option : No Option Orientation : Vertical

Correct Marks : 4 Wrong Marks : 1

If $\sin^4 \alpha + 4 \cos^4 \beta + 2 = 4\sqrt{2} \sin \alpha \cos \beta$;
 $\alpha, \beta \in [0, \pi]$, then $\cos(\alpha + \beta) - \cos(\alpha - \beta)$ is equal to :

Options :

1. $\sqrt{2}$

2. $-\sqrt{2}$

3. 0

4. -1

Question Number : 88 Question Type : MCQ Option Shuffling : Yes Display Question Number : Yes Single Line Question Option : No Option Orientation : Vertical

Correct Marks : 4 Wrong Marks : 1

यदि

$$\sin^4 \alpha + 4 \cos^4 \beta + 2 = 4\sqrt{2} \sin \alpha \cos \beta, \alpha, \beta \in [0, \pi] \text{ तो } \cos(\alpha + \beta) - \cos(\alpha - \beta) \text{ बराबर है :}$$

Options :

1. $\sqrt{2}$

2. $-\sqrt{2}$

3. 0

4. -1

Question Number : 88 Question Type : MCQ Option Shuffling : Yes Display Question Number : Yes Single Line Question Option : No Option Orientation : Vertical

Correct Marks : 4 Wrong Marks : 1

यदि

$$\sin^4 \alpha + 4 \cos^4 \beta + 2 = 4\sqrt{2} \sin \alpha \cos \beta, \alpha, \beta \in [0, \pi] \text{ तो } \cos(\alpha + \beta) - \cos(\alpha - \beta) =$$

_____.

Options :

1. $\sqrt{2}$

2. $-\sqrt{2}$

3. 0

4. -1

Question Number : 89 Question Type : MCQ Option Shuffling : Yes Display Question Number : Yes Single Line Question Option : No Option Orientation : Vertical

Correct Marks : 4 Wrong Marks : 1

एक झील से 25 m ऊपर एक बिन्दु P से एक बादल का उन्नयन कोण 30° है तथा P से झील में बादल के प्रतिबिम्ब का अवनमन कोण 60° है, तो झील की सतह से बादल की ऊँचाई (मीटर में) है :

Options :

1. 60
2. 50
3. 45
4. 42

Question Number : 89 Question Type : MCQ Option Shuffling : Yes Display Question Number : Yes Single Line Question Option : No Option Orientation : Vertical

Correct Marks : 4 Wrong Marks : 1

એક સરોવર થી 25 m ઉપર આવેલ એક બિંદુ P થી એક વાદળનો ઉત્સેધકોણ 30° અને આ સરોવરમાં આ વાદળના પ્રતિબિંબનો P બિંદુએથી અવસેધકોણ 60° છે. તો આ સરોવરની સપાટીથી વાદળની ઊંચાઈ (મીટરમાં) _____ છે.

Options :

1. 60
2. 50
3. 45
4. 42

Question Number : 89 Question Type : MCQ Option Shuffling : Yes Display Question Number : Yes Single Line Question Option : No Option Orientation : Vertical

Correct Marks : 4 Wrong Marks : 1

If the angle of elevation of a cloud from a point P which is 25 m above a lake be 30° and the angle of depression of reflection of the cloud in the lake from P be 60° , then the height of the cloud (in meters) from the surface of the lake is :

Options :

1. 60
2. 50
3. 45
4. 42

Question Number : 90 Question Type : MCQ Option Shuffling : Yes Display Question Number : Yes Single Line Question Option : No Option Orientation : Vertical

Correct Marks : 4 Wrong Marks : 1

The expression $\sim(\sim p \rightarrow q)$ is logically equivalent to :

Options :

1. $p \wedge q$
2. $p \wedge \sim q$
3. $\sim p \wedge q$
4. $\sim p \wedge \sim q$

Question Number : 90 Question Type : MCQ Option Shuffling : Yes Display Question Number : Yes Single Line Question Option : No Option Orientation : Vertical

Correct Marks : 4 Wrong Marks : 1

વ્યંજક $\sim(\sim p \rightarrow q)$ નિમ્ન મેં સે કિસકે તર્ક સંગત તુલ્ય હૈ?

Options :

1. $p \wedge q$
2. $p \wedge \sim q$
3. $\sim p \wedge q$
4. $\sim p \wedge \sim q$

Question Number : 90 Question Type : MCQ Option Shuffling : Yes Display Question Number : Yes Single Line Question Option : No Option Orientation : Vertical

Correct Marks : 4 Wrong Marks : 1

નિરૂપણ $\sim(\sim p \rightarrow q)$ એ તાર્કિક રીતે _____ ને સમકક્ષ છે.

Options :

1. $p \wedge q$
2. $p \wedge \sim q$
3. $\sim p \wedge q$
4. $\sim p \wedge \sim q$