

## Banaras Hindu University

**Question Paper Name:** 486 23rd May 2019 Shift 1  
**Subject Name:** 486  
**Creation Date:** 2019-05-23 13:20:51  
**Duration:** 120  
**Total Marks:** 360  
**Display Marks:** Yes  
**Share Answer Key With Delivery Engine:** Yes  
**Actual Answer Key:** Yes

### MSc Computer Science

**Group Number :** 1  
**Group Id :** 65898813  
**Group Maximum Duration :** 0  
**Group Minimum Duration :** 120  
**Revisit allowed for view? :** No  
**Revisit allowed for edit? :** No  
**Break time:** 0  
**Group Marks:** 360

### MSc Computer Science

**Section Id :** 65898813  
**Section Number :** 1  
**Section type :** Online  
**Mandatory or Optional:** Mandatory  
**Number of Questions:** 120  
**Number of Questions to be attempted:** 120  
**Section Marks:** 360  
**Display Number Panel:** Yes  
**Group All Questions:** No

**Sub-Section Number:** 1  
**Sub-Section Id:** 65898813  
**Question Shuffling Allowed :** Yes

**Question Number : 1 Question Id : 6589881321 Question Type : MCQ Option Shuffling : Yes Display Question Number : Yes**  
**Single Line Question Option : No Option Orientation : Vertical Allowed Progression : Yes Number of Replay : 999 Play On Load : No Control Enable : Yes**

**Correct Marks : 3 Wrong Marks : 1**

Question Label : Multiple Choice Question

What is the ready state of a process ?

**Options :**

1. when process is waiting for CPU to run

2. when process is unable to run until some task has been completed
3. when process is using the CPU
4. when process is waiting for I/O operations

Question Number : 2 Question Id : 6589881322 Question Type : MCQ Option Shuffling : Yes Display Question Number : Yes  
Single Line Question Option : No Option Orientation : Vertical Allowed Progression : Yes Number of Replay : 999 Play On Load :  
No Control Enable : Yes

Correct Marks : 3 Wrong Marks : 1

Question Label : Multiple Choice Question

A set of processes is in deadlock state if :

Options :

1. each process is blocked and will remain so forever
2. each process is terminated
3. all processes are trying to kill each other
4. all processes are in sleeping state

Question Number : 3 Question Id : 6589881323 Question Type : MCQ Option Shuffling : Yes Display Question Number : Yes  
Single Line Question Option : No Option Orientation : Vertical Allowed Progression : Yes Number of Replay : 999 Play On Load :  
No Control Enable : Yes

Correct Marks : 3 Wrong Marks : 1

Question Label : Multiple Choice Question

A process stack does not contain :

Options :

1. Function parameters
2. Local variables
3. Return addresses
4. PID of child process

Question Number : 4 Question Id : 6589881324 Question Type : MCQ Option Shuffling : Yes Display Question Number : Yes  
Single Line Question Option : No Option Orientation : Vertical Allowed Progression : Yes Number of Replay : 999 Play On Load :  
No Control Enable : Yes

Correct Marks : 3 Wrong Marks : 1

Question Label : Multiple Choice Question

The primary distinction between the short term scheduler and the long term scheduler is :

Options :

1. The length of their queues

2. The type of processes they schedule
3. The frequency of their execution
4. The length of their stack

Question Number : 5 Question Id : 6589881325 Question Type : MCQ Option Shuffling : Yes Display Question Number : Yes  
Single Line Question Option : No Option Orientation : Vertical Allowed Progression : Yes Number of Replay : 999 Play On Load :  
No Control Enable : Yes

Correct Marks : 3 Wrong Marks : 1

Question Label : Multiple Choice Question

When several processes access the same data concurrently and the outcome of the execution depends on the particular order in which the access takes place, is called :

Options :

1. dynamic condition
2. race condition
3. essential condition
4. critical condition

Question Number : 6 Question Id : 6589881326 Question Type : MCQ Option Shuffling : Yes Display Question Number : Yes  
Single Line Question Option : No Option Orientation : Vertical Allowed Progression : Yes Number of Replay : 999 Play On Load :  
No Control Enable : Yes

Correct Marks : 3 Wrong Marks : 1

Question Label : Multiple Choice Question

Message passing system allows processes to :

Options :

1. communicate with one another without resorting to shared data
2. communicate with one another by resorting to shared data
3. share data
4. use hardware instructions

Question Number : 7 Question Id : 6589881327 Question Type : MCQ Option Shuffling : Yes Display Question Number : Yes  
Single Line Question Option : No Option Orientation : Vertical Allowed Progression : Yes Number of Replay : 999 Play On Load :  
No Control Enable : Yes

Correct Marks : 3 Wrong Marks : 1

Question Label : Multiple Choice Question

With round robin scheduling algorithm in a time shared system :

Options :

1. using very large time slices converts it into first come first served scheduling algorithm
2. using very small time slices converts it into first come first served scheduling algorithm
3. using extremely small time slices increases performance
4. using very small time slices converts it into shortest job first algorithm

Question Number : 8 Question Id : 6589881328 Question Type : MCQ Option Shuffling : Yes Display Question Number : Yes  
Single Line Question Option : No Option Orientation : Vertical Allowed Progression : Yes Number of Replay : 999 Play On Load :  
No Control Enable : Yes

Correct Marks : 3 Wrong Marks : 1

Question Label : Multiple Choice Question

Which of the following statements are *true* ?

- I. Shortest remaining time first scheduling may cause starvation
- II. Preemptive scheduling may cause starvation
- III. Round robin is better than FCFS in terms of response time

Options :

1. I only
2. I and III only
3. II and III only
4. I, II and III

Question Number : 9 Question Id : 6589881329 Question Type : MCQ Option Shuffling : Yes Display Question Number : Yes  
Single Line Question Option : No Option Orientation : Vertical Allowed Progression : Yes Number of Replay : 999 Play On Load :  
No Control Enable : Yes

Correct Marks : 3 Wrong Marks : 1

Question Label : Multiple Choice Question

The segment of code in which the process may change common variables, update tables, write into files is known as :

Options :

1. program
2. critical section
3. non - critical section
4. synchronizing

Question Number : 10 Question Id : 6589881330 Question Type : MCQ Option Shuffling : Yes Display Question Number : Yes  
Single Line Question Option : No Option Orientation : Vertical Allowed Progression : Yes Number of Replay : 999 Play On Load :  
No Control Enable : Yes

Correct Marks : 3 Wrong Marks : 1

Question Label : Multiple Choice Question

Semaphore is a/an ..... to solve the critical section problem.

Options :

1. hardware for a system
2. special program for a system
3. integer variable
4. none of the mentioned

Question Number : 11 Question Id : 6589881331 Question Type : MCQ Option Shuffling : Yes Display Question Number : Yes  
Single Line Question Option : No Option Orientation : Vertical Allowed Progression : Yes Number of Replay : 999 Play On Load :  
No Control Enable : Yes

Correct Marks : 3 Wrong Marks : 1

Question Label : Multiple Choice Question

The circular wait condition can be prevented by :

Options :

1. defining a linear ordering of resource types
2. using thread
3. using pipes
4. using semaphore

Question Number : 12 Question Id : 6589881332 Question Type : MCQ Option Shuffling : Yes Display Question Number : Yes  
Single Line Question Option : No Option Orientation : Vertical Allowed Progression : Yes Number of Replay : 999 Play On Load :  
No Control Enable : Yes

Correct Marks : 3 Wrong Marks : 1

Question Label : Multiple Choice Question

Which one of the following is the deadlock avoidance algorithm ?

Options :

1. banker's algorithm
2. round-robin algorithm
3. elevator algorithm
4. karn's algorithm

Question Number : 13 Question Id : 6589881333 Question Type : MCQ Option Shuffling : Yes Display Question Number : Yes  
Single Line Question Option : No Option Orientation : Vertical Allowed Progression : Yes Number of Replay : 999 Play On Load :  
No Control Enable : Yes

Correct Marks : 3 Wrong Marks : 1

Question Label : Multiple Choice Question

The page table contains :

Options :

1. base address of each page in physical memory
2. page offset
3. page size
4. frame size

Question Number : 14 Question Id : 6589881334 Question Type : MCQ Option Shuffling : Yes Display Question Number : Yes  
Single Line Question Option : No Option Orientation : Vertical Allowed Progression : Yes Number of Replay : 999 Play On Load :  
No Control Enable : Yes

Correct Marks : 3 Wrong Marks : 1

Question Label : Multiple Choice Question

In segmentation, each address is specified by :

Options :

1. a segment number & offset
2. an offset & value
3. a value & segment number
4. a key & value

Question Number : 15 Question Id : 6589881335 Question Type : MCQ Option Shuffling : Yes Display Question Number : Yes  
Single Line Question Option : No Option Orientation : Vertical Allowed Progression : Yes Number of Replay : 999 Play On Load :  
No Control Enable : Yes

Correct Marks : 3 Wrong Marks : 1

Question Label : Multiple Choice Question

Consider a disk queue with requests for I/O to blocks on cylinders: 98, 183, 37, 122, 14, 124, 65, and 67. Considering FCFS (first cum first served) scheduling, the total number of head movements is, if the disk head is initially at 53 :

Options :

1. 600
2. 620
3. 630

4. 640

Question Number : 16 Question Id : 6589881336 Question Type : MCQ Option Shuffling : Yes Display Question Number : Yes  
Single Line Question Option : No Option Orientation : Vertical Allowed Progression : Yes Number of Replay : 999 Play On Load :  
No Control Enable : Yes

Correct Marks : 3 Wrong Marks : 1

Question Label : Multiple Choice Question

The strategy used when two computers using IPv6 want to communicate with each other and the packet must pass through a region that uses IPv4 is :

Options :

1. Dual stack
2. Header translation
3. Conversion
4. Tunneling

Question Number : 17 Question Id : 6589881337 Question Type : MCQ Option Shuffling : Yes Display Question Number : Yes  
Single Line Question Option : No Option Orientation : Vertical Allowed Progression : Yes Number of Replay : 999 Play On Load :  
No Control Enable : Yes

Correct Marks : 3 Wrong Marks : 1

Question Label : Multiple Choice Question

In the slow-start algorithm, the size of the congestion window increases ..... until it reaches a threshold.

Options :

1. Exponentially
2. Additively
3. Multiplicatively
4. Slowly

Question Number : 18 Question Id : 6589881338 Question Type : MCQ Option Shuffling : Yes Display Question Number : Yes  
Single Line Question Option : No Option Orientation : Vertical Allowed Progression : Yes Number of Replay : 999 Play On Load :  
No Control Enable : Yes

Correct Marks : 3 Wrong Marks : 1

Question Label : Multiple Choice Question

Which statement(s) is/are true regarding ICMP packet ?

- A. They acknowledge receipt of TCP segments.
- B. They guarantee datagram delivery.
- C. They are encapsulated within IP datagrams.
- D. They can provide hosts with information about network problems.

Options :

- 1. A only
- 2. B and C
- 3. C and D
- 4. B, C and D

Question Number : 19 Question Id : 6589881339 Question Type : MCQ Option Shuffling : Yes Display Question Number : Yes  
Single Line Question Option : No Option Orientation : Vertical Allowed Progression : Yes Number of Replay : 999 Play On Load :  
No Control Enable : Yes

Correct Marks : 3 Wrong Marks : 1

Question Label : Multiple Choice Question

An Internet Service Provider (ISP) has the following chunk of CIDR-based (Classless) IP addresses available with it: 245.248.128.0/20. The ISP wants to give half of this chunk of addresses to Organization A, and a quarter to Organization B, while retaining the remaining with itself. Which of the following is a valid allocation of addresses to A and B ?

Options :

- 1. 245.248.136.0/21 and 245.248.128.0/22
- 2. 245.248.128.0/21 and 245.248.128.0/22
- 3. 245.248.132.0/22 and 245.248.132.0/21
- 4. 245.248.136.0/22 and 245.248.132.0/21

Question Number : 20 Question Id : 6589881340 Question Type : MCQ Option Shuffling : Yes Display Question Number : Yes  
Single Line Question Option : No Option Orientation : Vertical Allowed Progression : Yes Number of Replay : 999 Play On Load :  
No Control Enable : Yes

Correct Marks : 3 Wrong Marks : 1

Question Label : Multiple Choice Question

One of the header fields in an IP datagram is the Time to Live (TTL) field. Which of the following statements best explains the need for this field ?

Options :

- 1. It can be used to prioritize packets



2. It can be used to reduce delays
3. It can be used to optimize throughput
4. It can be used to prevent packet looping

Question Number : 21 Question Id : 6589881341 Question Type : MCQ Option Shuffling : Yes Display Question Number : Yes  
Single Line Question Option : No Option Orientation : Vertical Allowed Progression : Yes Number of Replay : 999 Play On Load :  
No Control Enable : Yes

Correct Marks : 3 Wrong Marks : 1

Question Label : Multiple Choice Question

The message 11001001 is to be transmitted using the CRC polynomial  $x^3 + 1$  to protect it from errors. The message that should be transmitted is :

Options :

1. 11001001000
2. 11001001011
3. 11001010
4. 110010010011

Question Number : 22 Question Id : 6589881342 Question Type : MCQ Option Shuffling : Yes Display Question Number : Yes  
Single Line Question Option : No Option Orientation : Vertical Allowed Progression : Yes Number of Replay : 999 Play On Load :  
No Control Enable : Yes

Correct Marks : 3 Wrong Marks : 1

Question Label : Multiple Choice Question

How many bits are allocated for network id (NID) and host id (HID) in the IP address 25.193.155.233 ?

Options :

1. 24 bit for NID, 8 bits for HID
2. 8 bit for NID, 24 bits for HID
3. 16 bit for NID, 16 bits for HID
4. 24 bit for NID, 16 bits for HID

Question Number : 23 Question Id : 6589881343 Question Type : MCQ Option Shuffling : Yes Display Question Number : Yes  
Single Line Question Option : No Option Orientation : Vertical Allowed Progression : Yes Number of Replay : 999 Play On Load :  
No Control Enable : Yes

Correct Marks : 3 Wrong Marks : 1

Question Label : Multiple Choice Question

The bandwidth of the line is 1.5 Mbps with round trip time (RTT) as 45 milliseconds. If the size of each packet is 1 KB (kilo bytes), then what is the efficiency in Stop and wait protocol ?

Options :

1. 20.3
2. 10.0
3. 10.8
4. 11

Question Number : 24 Question Id : 6589881344 Question Type : MCQ Option Shuffling : Yes Display Question Number : Yes  
Single Line Question Option : No Option Orientation : Vertical Allowed Progression : Yes Number of Replay : 999 Play On Load :  
No Control Enable : Yes

Correct Marks : 3 Wrong Marks : 1

Question Label : Multiple Choice Question

The connection establishment procedure in TCP is susceptible to a serious security problem called the ..... attack.

Options :

1. ACK flooding
2. FIN flooding
3. SYN flooding
4. Denial of Service

Question Number : 25 Question Id : 6589881345 Question Type : MCQ Option Shuffling : Yes Display Question Number : Yes  
Single Line Question Option : No Option Orientation : Vertical Allowed Progression : Yes Number of Replay : 999 Play On Load :  
No Control Enable : Yes

Correct Marks : 3 Wrong Marks : 1

Question Label : Multiple Choice Question

In Manchester and Differential Manchester encoding, the transition at the middle of the bit is used for .....

Options :

1. Bit transfer
2. Baud transfer
3. Synchronization
4. Bit conversion

Question Number : 26 Question Id : 6589881346 Question Type : MCQ Option Shuffling : Yes Display Question Number : Yes  
Single Line Question Option : No Option Orientation : Vertical Allowed Progression : Yes Number of Replay : 999 Play On Load :  
No Control Enable : Yes

Correct Marks : 3 Wrong Marks : 1

Question Label : Multiple Choice Question

Valid statements in proposition calculus are :

Options :

1. Declarative statements which are either true or false
2. Declarative statements which are true as well as false
3. Any declarative sentence irrespective of its truth value
4. Declarative statements which are either true or false and Any declarative sentence irrespective of its truth value both

Question Number : 27 Question Id : 6589881347 Question Type : MCQ Option Shuffling : Yes Display Question Number : Yes  
Single Line Question Option : No Option Orientation : Vertical Allowed Progression : Yes Number of Replay : 999 Play On Load :  
No Control Enable : Yes

Correct Marks : 3 Wrong Marks : 1

Question Label : Multiple Choice Question

Consider the statement "If  $1 + 1 = 3$  then fish fly". The truth value of this statement is :

Options :

1. True
2. False
3. True and False both
4. Statement is not valid

Question Number : 28 Question Id : 6589881348 Question Type : MCQ Option Shuffling : Yes Display Question Number : Yes  
Single Line Question Option : No Option Orientation : Vertical Allowed Progression : Yes Number of Replay : 999 Play On Load :  
No Control Enable : Yes

Correct Marks : 3 Wrong Marks : 1

Question Label : Multiple Choice Question

Let there be  $n$  statement variables. The total number of possible well-formed formula of these  $n$  variables are :

Options :

1.  $2n$
2.  $2^n$
3.  $2^{2^n}$

4.  $n!$

Question Number : 29 Question Id : 6589881349 Question Type : MCQ Option Shuffling : Yes Display Question Number : Yes  
Single Line Question Option : No Option Orientation : Vertical Allowed Progression : Yes Number of Replay : 999 Play On Load :  
No Control Enable : Yes

Correct Marks : 3 Wrong Marks : 1

Question Label : Multiple Choice Question

$\neg P$  is valid implication of the statements :

Options :

1.  $Q, P \rightarrow Q$

2.  $\neg Q, P \rightarrow Q$

3.  $\neg Q, \neg P \rightarrow Q$

4.  $\neg Q, P \rightarrow \neg Q$

Question Number : 30 Question Id : 6589881350 Question Type : MCQ Option Shuffling : Yes Display Question Number : Yes  
Single Line Question Option : No Option Orientation : Vertical Allowed Progression : Yes Number of Replay : 999 Play On Load :  
No Control Enable : Yes

Correct Marks : 3 Wrong Marks : 1

Question Label : Multiple Choice Question

Let  $A$  and  $B$  be two sets having  $m$  and  $n$  elements respectively, i.e.  $|A| = m$ ,  
 $|B| = n$ . Then the total number of one-one functions from  $A$  to  $B$  :

Options :

1.  $2^{n(n-1)(n-2)\dots(n-m+1)}$

2.  $m^n$

3.  $2^{mn}$

4.  $n(n-1)(n-2)\dots(n-m+1)$

Question Number : 31 Question Id : 6589881351 Question Type : MCQ Option Shuffling : Yes Display Question Number : Yes  
Single Line Question Option : No Option Orientation : Vertical Allowed Progression : Yes Number of Replay : 999 Play On Load :  
No Control Enable : Yes

Correct Marks : 3 Wrong Marks : 1

Question Label : Multiple Choice Question

Which statement is not necessarily true about lattice ?

Options :

1. Lattice is partial order set

Two element subsets have both least upper bound and greatest lower bound

Two element subsets have either least upper bound or greatest lower bound

Every subset has least upper bound and greatest lower bound

Question Number : 32 Question Id : 6589881352 Question Type : MCQ Option Shuffling : Yes Display Question Number : Yes  
Single Line Question Option : No Option Orientation : Vertical Allowed Progression : Yes Number of Replay : 999 Play On Load :  
No Control Enable : Yes

Correct Marks : 3 Wrong Marks : 1

Question Label : Multiple Choice Question

Chromatic number of Hasse diagram of any POSET is :

Options :

1. Total number of elements in POSET.

2. Two times the total number of elements in POSET.

3. Exactly 2.

4. Number of levels in Hasse diagram.

Question Number : 33 Question Id : 6589881353 Question Type : MCQ Option Shuffling : Yes Display Question Number : Yes  
Single Line Question Option : No Option Orientation : Vertical Allowed Progression : Yes Number of Replay : 999 Play On Load :  
No Control Enable : Yes

Correct Marks : 3 Wrong Marks : 1

Question Label : Multiple Choice Question

A connected planar graph has 30 edges and its planar representation divides the plane into 20 regions. The total number of vertices in a graph :

Options :

1. 10

2. 12

3. 11

4. 13

Question Number : 34 Question Id : 6589881354 Question Type : MCQ Option Shuffling : Yes Display Question Number : Yes  
Single Line Question Option : No Option Orientation : Vertical Allowed Progression : Yes Number of Replay : 999 Play On Load :  
No Control Enable : Yes

Correct Marks : 3 Wrong Marks : 1

Question Label : Multiple Choice Question

Consider the following multi graph :

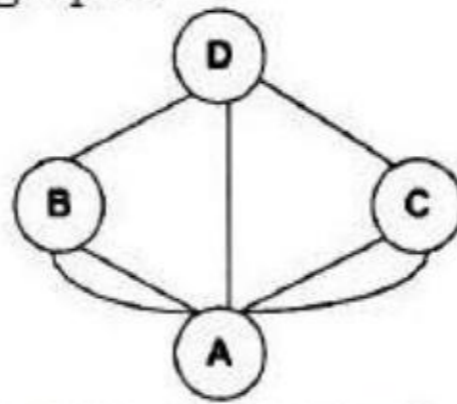

The total number of Euler circuit in above graph is :

Options :

1. 1
2. 2
3. 3
4. 0

Question Number : 35 Question Id : 6589881355 Question Type : MCQ Option Shuffling : Yes Display Question Number : Yes  
Single Line Question Option : No Option Orientation : Vertical Allowed Progression : Yes Number of Replay : 999 Play On Load :  
No Control Enable : Yes

Correct Marks : 3 Wrong Marks : 1

Question Label : Multiple Choice Question

How many symmetric relations are there on the set having three elements :

Options :

1. 8
2. 16
3. 64
4. 3

Question Number : 36 Question Id : 6589881356 Question Type : MCQ Option Shuffling : Yes Display Question Number : Yes  
Single Line Question Option : No Option Orientation : Vertical Allowed Progression : Yes Number of Replay : 999 Play On Load :  
No Control Enable : Yes

Correct Marks : 3 Wrong Marks : 1

Question Label : Multiple Choice Question

Let E1 and E2 be two entities in an E/R diagram with simple single-valued attributes. R1 and R2 are two relationships between E1 and E2, where R1 is one-to-many and R2 is many-to-many. R1 and R2 do not have any attributes of their own. What is the minimum number of tables required to represent this situation in the relational model ?

Options :

1. 2

2. 3

3. 4

4. 5

Question Number : 37 Question Id : 6589881357 Question Type : MCQ Option Shuffling : Yes Display Question Number : Yes  
Single Line Question Option : No Option Orientation : Vertical Allowed Progression : Yes Number of Replay : 999 Play On Load :  
No Control Enable : Yes

Correct Marks : 3 Wrong Marks : 1

Question Label : Multiple Choice Question

Aggregate functions can be used in the select list or the ..... clause of a select statement or sub query. They cannot be used in a ..... clause.

Options :

1. Where, having

2. Having, where

3. Group by, having

4. Group by, where

Question Number : 38 Question Id : 6589881358 Question Type : MCQ Option Shuffling : Yes Display Question Number : Yes  
Single Line Question Option : No Option Orientation : Vertical Allowed Progression : Yes Number of Replay : 999 Play On Load :  
No Control Enable : Yes

Correct Marks : 3 Wrong Marks : 1

Question Label : Multiple Choice Question

Given the relations EMPLOYEE (name, salary, deptno) and DEPARTMENT (deptno, deptname, address), Which of the following queries cannot be expressed using the basic relational algebra operations ( $U, -, \times, \pi, \sigma, \rho$ ) ?

Options :

1. Department address of every employee

2. Employees whose name is the same as their department name

3. The sum of all employees' salaries

4. All employees of a given department

Question Number : 39 Question Id : 6589881359 Question Type : MCQ Option Shuffling : Yes Display Question Number : Yes  
Single Line Question Option : No Option Orientation : Vertical Allowed Progression : Yes Number of Replay : 999 Play On Load :  
No Control Enable : Yes

Correct Marks : 3 Wrong Marks : 1

Question Label : Multiple Choice Question

The relation BOOK (title, price) contains the titles and prices of different books. Assuming that no two books have the same price, what does the following SQL query list ?

Select title from BOOK as B where (select count(\*) from BOOK as T where T.price > B.price) < 5

Options :

1. Titles of the four most expensive books
2. Title of the fifth most inexpensive book
3. Title of the fifth most expensive book
4. Titles of the five most expensive books

Question Number : 40 Question Id : 6589881360 Question Type : MCQ Option Shuffling : Yes Display Question Number : Yes  
Single Line Question Option : No Option Orientation : Vertical Allowed Progression : Yes Number of Replay : 999 Play On Load :  
No Control Enable : Yes

Correct Marks : 3 Wrong Marks : 1

Question Label : Multiple Choice Question

Consider a relation scheme  $R = (A, B, C, D, E, H)$  on which the following functional dependencies hold :  $\{A \rightarrow B, BC \rightarrow D, E \rightarrow C, D \rightarrow A\}$ . What are the candidate keys of R ?

Options :

1. AE, BE
2. AE, BE, DE
3. AEH, BEH, BCH
4. AEH, BEH, DEH

Question Number : 41 Question Id : 6589881361 Question Type : MCQ Option Shuffling : Yes Display Question Number : Yes  
Single Line Question Option : No Option Orientation : Vertical Allowed Progression : Yes Number of Replay : 999 Play On Load :  
No Control Enable : Yes

Correct Marks : 3 Wrong Marks : 1

Question Label : Multiple Choice Question

Which one of the following statements about normal forms is FALSE ?

Options :



1. BCNF is stricter than 3NF

2. Lossless, dependency-preserving decomposition into 3NF is always possible

3. Lossless, dependency-preserving decomposition into BCNF is always possible

4. Any relation with two attributes is in BCNF

Question Number : 42 Question Id : 6589881362 Question Type : MCQ Option Shuffling : Yes Display Question Number : Yes  
Single Line Question Option : No Option Orientation : Vertical Allowed Progression : Yes Number of Replay : 999 Play On Load :  
No Control Enable : Yes

Correct Marks : 3 Wrong Marks : 1

Question Label : Multiple Choice Question

In a schema with attributes A, B, C, D and E following set of functional dependencies are given :

$\{A \rightarrow B, A \rightarrow C, CD \rightarrow E, B \rightarrow D, E \rightarrow A\}$

Which of the following functional dependencies is NOT implied by the above set ?

Options :

1.  $CD \rightarrow AC$

2.  $BD \rightarrow CD$

3.  $BC \rightarrow CD$

4.  $AC \rightarrow BC$

Question Number : 43 Question Id : 6589881363 Question Type : MCQ Option Shuffling : Yes Display Question Number : Yes  
Single Line Question Option : No Option Orientation : Vertical Allowed Progression : Yes Number of Replay : 999 Play On Load :  
No Control Enable : Yes

Correct Marks : 3 Wrong Marks : 1

Question Label : Multiple Choice Question

In a B+ tree, suppose that the search key field is  $V = 9$  bytes long, the block size is  $B = 512$  bytes, a record pointer is  $Pr = 7$  bytes, and a block pointer is  $P = 6$  bytes. What is the maximum possible order of internal node such that a node must fit into a single block ?

Options :

1. 23

2. 34

3. 32

4.  $2^9$

Question Number : 44 Question Id : 6589881364 Question Type : MCQ Option Shuffling : Yes Display Question Number : Yes  
Single Line Question Option : No Option Orientation : Vertical Allowed Progression : Yes Number of Replay : 999 Play On Load :  
No Control Enable : Yes

Correct Marks : 3 Wrong Marks : 1

Question Label : Multiple Choice Question

Two schedules are said to be ..... if the order of any two conflicting operations is the same in both schedules.

Options :

1. Conflict schedules
2. Conflict equivalent
3. Serializable
4. logically equal

Question Number : 45 Question Id : 6589881365 Question Type : MCQ Option Shuffling : Yes Display Question Number : Yes  
Single Line Question Option : No Option Orientation : Vertical Allowed Progression : Yes Number of Replay : 999 Play On Load :  
No Control Enable : Yes

Correct Marks : 3 Wrong Marks : 1

Question Label : Multiple Choice Question

In wait-die, an older transaction is allowed to *wait for a younger transaction*, whereas a younger transaction requesting an item held by an older transaction is aborted and restarted.

Options :

1. older, younger, younger
2. younger, older, larger
3. older, younger, older
4. Newer, smaller, younger

Question Number : 46 Question Id : 6589881366 Question Type : MCQ Option Shuffling : Yes Display Question Number : Yes  
Single Line Question Option : No Option Orientation : Vertical Allowed Progression : Yes Number of Replay : 999 Play On Load :  
No Control Enable : Yes

Correct Marks : 3 Wrong Marks : 1

Question Label : Multiple Choice Question

Which of the following is a desirable property of a module ?

Options :

1. Independency
2. Low cohesiveness
3. High coupling
4. Multi functional

Question Number : 47 Question Id : 6589881367 Question Type : MCQ Option Shuffling : Yes Display Question Number : Yes  
Single Line Question Option : No Option Orientation : Vertical Allowed Progression : Yes Number of Replay : 999 Play On Load :  
No Control Enable : Yes

Correct Marks : 3 Wrong Marks : 1

Question Label : Multiple Choice Question

The extent to which the software can continue to operate correctly despite the introduction of invalid input is called as :

Options :

1. reliability
2. robustness
3. fault-tolerance
4. portability

Question Number : 48 Question Id : 6589881368 Question Type : MCQ Option Shuffling : Yes Display Question Number : Yes  
Single Line Question Option : No Option Orientation : Vertical Allowed Progression : Yes Number of Replay : 999 Play On Load :  
No Control Enable : Yes

Correct Marks : 3 Wrong Marks : 1

Question Label : Multiple Choice Question

Cross-compiler is a compiler :

Options :

1. which is written in a language that is different from the source language
2. that generates object code for its host machine
3. which is written in a language that is same as the source language
4. that runs on one machine but produces object code for another machine

Question Number : 49 Question Id : 6589881369 Question Type : MCQ Option Shuffling : Yes Display Question Number : Yes  
Single Line Question Option : No Option Orientation : Vertical Allowed Progression : Yes Number of Replay : 999 Play On Load :  
No Control Enable : Yes

Correct Marks : 3 Wrong Marks : 1

Question Label : Multiple Choice Question

Maximum effort consumed by the phase in software life cycle is :

Options :

1. Design
2. Testing
3. Requirement Analysis
4. Coding

Question Number : 50 Question Id : 6589881370 Question Type : MCQ Option Shuffling : Yes Display Question Number : Yes  
Single Line Question Option : No Option Orientation : Vertical Allowed Progression : Yes Number of Replay : 999 Play On Load :  
No Control Enable : Yes

Correct Marks : 3 Wrong Marks : 1

Question Label : Multiple Choice Question

Which test refers to the retesting of a unit, integration and system after modification, in order to ascertain that the change has not introduced new faults ?

Options :

1. Regression Test
2. Smoke Test
3. Alpha Test
4. Beta Test

Question Number : 51 Question Id : 6589881371 Question Type : MCQ Option Shuffling : Yes Display Question Number : Yes  
Single Line Question Option : No Option Orientation : Vertical Allowed Progression : Yes Number of Replay : 999 Play On Load :  
No Control Enable : Yes

Correct Marks : 3 Wrong Marks : 1

Question Label : Multiple Choice Question

A terabyte comprises :

Options :

1. 1025 byte
2. 1024 byte
3. 1024 bits
4. 1024 gigabyte

Question Number : 52 Question Id : 6589881372 Question Type : MCQ Option Shuffling : Yes Display Question Number : Yes  
Single Line Question Option : No Option Orientation : Vertical Allowed Progression : Yes Number of Replay : 999 Play On Load :  
No Control Enable : Yes

Correct Marks : 3 Wrong Marks : 1

Question Label : Multiple Choice Question

Which among following is commonly used language in Android applications ?

Options :

1. C
2. PHP
3. C++
4. Java

Question Number : 53 Question Id : 6589881373 Question Type : MCQ Option Shuffling : Yes Display Question Number : Yes  
Single Line Question Option : No Option Orientation : Vertical Allowed Progression : Yes Number of Replay : 999 Play On Load :  
No Control Enable : Yes

Correct Marks : 3 Wrong Marks : 1

Question Label : Multiple Choice Question

Which program is run by BIOS to check hardware components are working properly while computer is turned ON ?

Options :

1. DMOS
2. POST
3. CMOS
4. RIP

Question Number : 54 Question Id : 6589881374 Question Type : MCQ Option Shuffling : Yes Display Question Number : Yes  
Single Line Question Option : No Option Orientation : Vertical Allowed Progression : Yes Number of Replay : 999 Play On Load :  
No Control Enable : Yes

Correct Marks : 3 Wrong Marks : 1

Question Label : Multiple Choice Question

..... monitors user activity on internet and transmit that information in background to someone else :

Options :

1. Malware
2. Spyware
3. Adware

#### 4. Monitor

Question Number : 55 Question Id : 6589881375 Question Type : MCQ Option Shuffling : Yes Display Question Number : Yes  
Single Line Question Option : No Option Orientation : Vertical Allowed Progression : Yes Number of Replay : 999 Play On Load :  
No Control Enable : Yes

Correct Marks : 3 Wrong Marks : 1

Question Label : Multiple Choice Question

Who coined the term 'Internet of Things' ?

Options :

1. Bill Gates
2. Kevin Ashton
3. Steve Jobs
4. Charles Babbage

Question Number : 56 Question Id : 6589881376 Question Type : MCQ Option Shuffling : Yes Display Question Number : Yes  
Single Line Question Option : No Option Orientation : Vertical Allowed Progression : Yes Number of Replay : 999 Play On Load :  
No Control Enable : Yes

Correct Marks : 3 Wrong Marks : 1

Question Label : Multiple Choice Question

The group of bits 11001 is serially shifted (right-most bit first) into a 5-bit parallel output shift register with an initial state 01110. After three clock pulses, the register contains .....

Options :

1. 01110
2. 00001
3. 00101
4. 00110

Question Number : 57 Question Id : 6589881377 Question Type : MCQ Option Shuffling : Yes Display Question Number : Yes  
Single Line Question Option : No Option Orientation : Vertical Allowed Progression : Yes Number of Replay : 999 Play On Load :  
No Control Enable : Yes

Correct Marks : 3 Wrong Marks : 1

Question Label : Multiple Choice Question

Internal propagation delay of asynchronous counter is removed by :

Options :

1. Ripple counter
2. Ring counter

3. Modulus counter
4. Synchronous counter

Question Number : 58 Question Id : 6589881378 Question Type : MCQ Option Shuffling : Yes Display Question Number : Yes  
 Single Line Question Option : No Option Orientation : Vertical Allowed Progression : Yes Number of Replay : 999 Play On Load :  
 No Control Enable : Yes

Correct Marks : 3 Wrong Marks : 1

Question Label : Multiple Choice Question

Consider the following circuit involving three D-type flip-flops used in a certain type of counter configuration

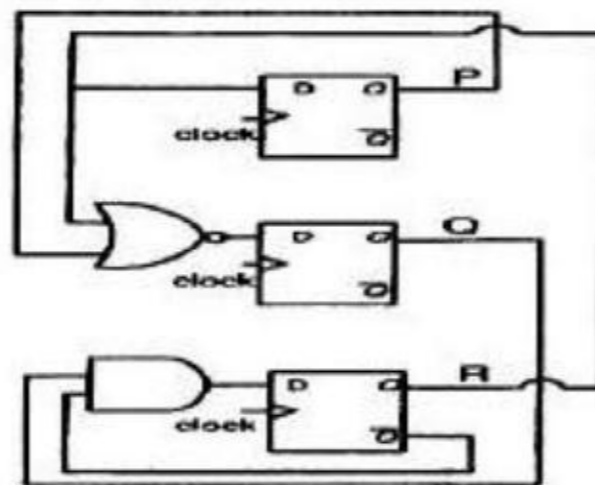

Some instance prior to the occurrence of the clock edge, P, Q and R have a value 0, 1 and 0 respectively, what shall be the value of PQR after the clock edge ?

Options :

1. 000
2. 001
3. 010
4. 011

Question Number : 59 Question Id : 6589881379 Question Type : MCQ Option Shuffling : Yes Display Question Number : Yes  
 Single Line Question Option : No Option Orientation : Vertical Allowed Progression : Yes Number of Replay : 999 Play On Load :  
 No Control Enable : Yes

Correct Marks : 3 Wrong Marks : 1

Question Label : Multiple Choice Question

In the given 4-to-1 multiplexer, if  $C_1 = 0$  and  $C_0 = 1$  then the output M is :

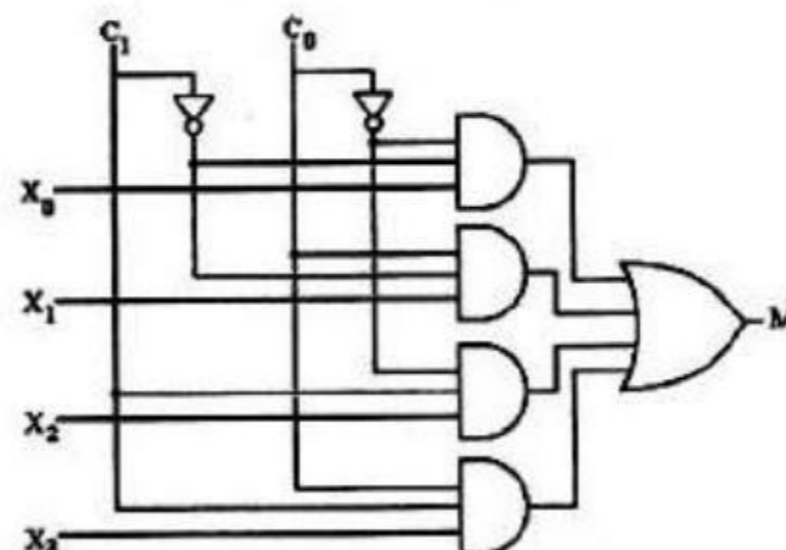

Options :

1.  $X_0$
2.  $X_1$
3.  $X_2$
4.  $X_3$

Question Number : 60 Question Id : 6589881380 Question Type : MCQ Option Shuffling : Yes Display Question Number : Yes  
Single Line Question Option : No Option Orientation : Vertical Allowed Progression : Yes Number of Replay : 999 Play On Load :  
No Control Enable : Yes

Correct Marks : 3 Wrong Marks : 1

Question Label : Multiple Choice Question

A major disadvantage of the mask ROM is that :

Options :

1. It is time consuming to change the stored data when system requirements change
2. It is very expensive to change the stored data when system requirements change
3. It cannot be reprogrammed if stored data needs to be changed
4. It has an extremely short life expectancy and requires frequent replacement

Question Number : 61 Question Id : 6589881381 Question Type : MCQ Option Shuffling : Yes Display Question Number : Yes  
Single Line Question Option : No Option Orientation : Vertical Allowed Progression : Yes Number of Replay : 999 Play On Load :  
No Control Enable : Yes

Correct Marks : 3 Wrong Marks : 1

Question Label : Multiple Choice Question

Assume that a 4-bit serial-in/serial-out shift register is initially clear. We wish to store the nibble 1100. What will be the 4-bit pattern after the second clock pulse ? (Right-most bit first)

Options :

1. 1100
2. 0011
3. 0000
4. 1111



Question Number : 62 Question Id : 6589881382 Question Type : MCQ Option Shuffling : Yes Display Question Number : Yes  
Single Line Question Option : No Option Orientation : Vertical Allowed Progression : Yes Number of Replay : 999 Play On Load :  
No Control Enable : Yes

Correct Marks : 3 Wrong Marks : 1

Question Label : Multiple Choice Question

How many full adders are required to construct an  $M$ -bit parallel adder ?

Options :

1.  $m/2$
2.  $m$
3.  $m - 1$
4.  $m + 1$

Question Number : 63 Question Id : 6589881383 Question Type : MCQ Option Shuffling : Yes Display Question Number : Yes  
Single Line Question Option : No Option Orientation : Vertical Allowed Progression : Yes Number of Replay : 999 Play On Load :  
No Control Enable : Yes

Correct Marks : 3 Wrong Marks : 1

Question Label : Multiple Choice Question

How many 3-to-8 line decoders with an enable input are needed to construct a 6-to-64 line decoder without using any other logic gates ?

Options :

1. 7
2. 8
3. 9
4. 10

Question Number : 64 Question Id : 6589881384 Question Type : MCQ Option Shuffling : Yes Display Question Number : Yes  
Single Line Question Option : No Option Orientation : Vertical Allowed Progression : Yes Number of Replay : 999 Play On Load :  
No Control Enable : Yes

Correct Marks : 3 Wrong Marks : 1

Question Label : Multiple Choice Question

On subtracting  $(010110)_2$  from  $(1011001)_2$  using 2's complement, we get :

Options :

1. 0111001
2. 1100101
3. 0110110

4. 1000011

Question Number : 65 Question Id : 6589881385 Question Type : MCQ Option Shuffling : Yes Display Question Number : Yes  
Single Line Question Option : No Option Orientation : Vertical Allowed Progression : Yes Number of Replay : 999 Play On Load :  
No Control Enable : Yes

Correct Marks : 3 Wrong Marks : 1

Question Label : Multiple Choice Question

Suppose only one multiplexer and one inverter is allowed to be used to implement any Boolean function of  $n$  variables. What is the minimum size of the multiplexer needed ?

Options :

1.  $2^n$  line to 1 line
2.  $2^{n+1}$  line to 1 line
3.  $2^{n-1}$  line to 1 line
4.  $2^{n-2}$  line to 1 line

Question Number : 66 Question Id : 6589881386 Question Type : MCQ Option Shuffling : Yes Display Question Number : Yes  
Single Line Question Option : No Option Orientation : Vertical Allowed Progression : Yes Number of Replay : 999 Play On Load :  
No Control Enable : Yes

Correct Marks : 3 Wrong Marks : 1

Question Label : Multiple Choice Question

A logic circuit whose output depends not only on present inputs but also on previous outputs is called :

Options :

1. sequential circuit
2. universal circuit
3. combinational circuit
4. XOR circuit

Question Number : 67 Question Id : 6589881387 Question Type : MCQ Option Shuffling : Yes Display Question Number : Yes  
Single Line Question Option : No Option Orientation : Vertical Allowed Progression : Yes Number of Replay : 999 Play On Load :  
No Control Enable : Yes

Correct Marks : 3 Wrong Marks : 1

Question Label : Multiple Choice Question

In a 11 bit computer instruction format, the size of the address field is 4 bits. The computer uses expanding opcode technique and has 5 two-address instructions and 32 one address instructions. The number of zero address instructions it can support is :

Options :

1. 256
2. 512
3. 2048
4. 272

Question Number : 68 Question Id : 6589881388 Question Type : MCQ Option Shuffling : Yes Display Question Number : Yes  
Single Line Question Option : No Option Orientation : Vertical Allowed Progression : Yes Number of Replay : 999 Play On Load : No Control Enable : Yes

Correct Marks : 3 Wrong Marks : 1

Question Label : Multiple Choice Question

A micro programmed control :

Options :

1. is faster than a hardwired unit
2. facilitates easy implementation of a new instruction
3. is useful when small programs are to be run
4. is useful when large programs are to be run

Question Number : 69 Question Id : 6589881389 Question Type : MCQ Option Shuffling : Yes Display Question Number : Yes  
Single Line Question Option : No Option Orientation : Vertical Allowed Progression : Yes Number of Replay : 999 Play On Load : No Control Enable : Yes

Correct Marks : 3 Wrong Marks : 1

Question Label : Multiple Choice Question

On receiving an interrupt from an I/O device, the CPU :

Options :

1. halts for a predetermined time
2. hands over control of the address bus and data bus to the interrupting device

3. branches off to the interrupt service routine immediately

4. branches off to the interrupt service routine after completion of the current instruction

Question Number : 70 Question Id : 6589881390 Question Type : MCQ Option Shuffling : Yes Display Question Number : Yes  
Single Line Question Option : No Option Orientation : Vertical Allowed Progression : Yes Number of Replay : 999 Play On Load : No Control Enable : Yes

Correct Marks : 3 Wrong Marks : 1

Question Label : Multiple Choice Question

A subtractor is not usually present in a computer. Possible reason is that :

Options :

1. it is expensive
2. it is not possible to design
3. the adder will take care of subtraction
4. statement is wrong

Question Number : 71 Question Id : 6589881391 Question Type : MCQ Option Shuffling : Yes Display Question Number : Yes  
Single Line Question Option : No Option Orientation : Vertical Allowed Progression : Yes Number of Replay : 999 Play On Load : No Control Enable : Yes

Correct Marks : 3 Wrong Marks : 1

Question Label : Multiple Choice Question

A byte addressable computer has a memory capacity of  $2^m$  kbytes and can perform  $2^n$  operations. An instruction involving 3 operands and one operator needs maximum of :

Options :

1.  $3m$  bits
2.  $3m + n$  bits
3.  $m + n$  bits
4.  $3m + n + 30$  bits

Question Number : 72 Question Id : 6589881392 Question Type : MCQ Option Shuffling : Yes Display Question Number : Yes  
Single Line Question Option : No Option Orientation : Vertical Allowed Progression : Yes Number of Replay : 999 Play On Load : No Control Enable : Yes

Correct Marks : 3 Wrong Marks : 1

Question Label : Multiple Choice Question

We have to build a memory capacity of 2048 bytes using  $128 \times 8$  RAM chips. Specify the size of decoder to select a RAM chip in memory :

Options :

1.  $3 \times 8$
2.  $4 \times 16$
3.  $2 \times 4$
4.  $5 \times 32$

Question Number : 73 Question Id : 6589881393 Question Type : MCQ Option Shuffling : Yes Display Question Number : Yes  
Single Line Question Option : No Option Orientation : Vertical Allowed Progression : Yes Number of Replay : 999 Play On Load :  
No Control Enable : Yes

Correct Marks : 3 Wrong Marks : 1

Question Label : Multiple Choice Question

A digital computer has a memory unit of  $64K \times 16$  and a cache memory of  $1K$  words. The cache uses direct mapping with a block size of four words. How many bits are there in tag ?

Options :

1. 2
2. 5
3. 7
4. 6

Question Number : 74 Question Id : 6589881394 Question Type : MCQ Option Shuffling : Yes Display Question Number : Yes  
Single Line Question Option : No Option Orientation : Vertical Allowed Progression : Yes Number of Replay : 999 Play On Load :  
No Control Enable : Yes

Correct Marks : 3 Wrong Marks : 1

Question Label : Multiple Choice Question

Virtual memory is :

Options :

1. an extremely large main memory
2. an extremely large secondary memory
3. an illusion of an extremely large memory
4. a type of memory used in super computers

Question Number : 75 Question Id : 6589881395 Question Type : MCQ Option Shuffling : Yes Display Question Number : Yes  
Single Line Question Option : No Option Orientation : Vertical Allowed Progression : Yes Number of Replay : 999 Play On Load :  
No Control Enable : Yes

Correct Marks : 3 Wrong Marks : 1

Question Label : Multiple Choice Question

In the case of Zero-address instruction method the operands are stored  
in .....

Options :

1. Registers
2. Accumulators
3. Push down stack
4. Cache

Question Number : 76 Question Id : 6589881396 Question Type : MCQ Option Shuffling : Yes Display Question Number : Yes  
Single Line Question Option : No Option Orientation : Vertical Allowed Progression : Yes Number of Replay : 999 Play On Load :  
No Control Enable : Yes

Correct Marks : 3 Wrong Marks : 1

Question Label : Multiple Choice Question

A hash table with 10 buckets with one slot per bucket is depicted in Figure. The  
symbols, S1 to S2 are initially entered using a hashing function with linear  
probing. The maximum number of comparisons needed in searching an item  
that is not present is :

S7
S1
S4
S2
S5
S6
S3

Options :

1. 6
2. 4
3. 5

4. 3

Question Number : 77 Question Id : 6589881397 Question Type : MCQ Option Shuffling : Yes Display Question Number : Yes  
Single Line Question Option : No Option Orientation : Vertical Allowed Progression : Yes Number of Replay : 999 Play On Load :  
No Control Enable : Yes

Correct Marks : 3 Wrong Marks : 1

Question Label : Multiple Choice Question

Let  $W(n)$  and  $A(n)$  denote respectively, the worst case and average case running time of an algorithm executed on an input of size  $n$ . Which of the following is ALWAYS TRUE ?

Options :

1.  $A(n) = \Omega(W(n))$
2.  $A(n) = \Theta(W(n))$
3.  $A(n) = O(W(n))$
4.  $A(n) = o(W(n))$

Question Number : 78 Question Id : 6589881398 Question Type : MCQ Option Shuffling : Yes Display Question Number : Yes  
Single Line Question Option : No Option Orientation : Vertical Allowed Progression : Yes Number of Replay : 999 Play On Load :  
No Control Enable : Yes

Correct Marks : 3 Wrong Marks : 1

Question Label : Multiple Choice Question

The height of a binary tree is the maximum number of edges in any root to leaf path. The maximum number of nodes in a binary tree of height  $h$  is :

Options :

1.  $2^h - 1$
2.  $2^{h-1} - 1$
3.  $2^{h+1}$
4.  $2^{h+1} - 1$

Question Number : 79 Question Id : 6589881399 Question Type : MCQ Option Shuffling : Yes Display Question Number : Yes  
Single Line Question Option : No Option Orientation : Vertical Allowed Progression : Yes Number of Replay : 999 Play On Load :  
No Control Enable : Yes

Correct Marks : 3 Wrong Marks : 1

Question Label : Multiple Choice Question

Suppose there are six files  $F_1, F_2, F_3, F_4, F_5, F_6$  with corresponding sizes 150 KB, 225 KB, 75 KB, 60 KB, 275 KB and 65 KB respectively. The files are to be stored on a sequential device in such a way that optimizes access time. In what order should the files be stored ?

Options :

1. F5, F2, F1, F3, F6, F4
2. F1, F2, F3, F4, F5, F6
3. F4, F6, F3, F1, F2, F5
4. F6, F5, F4, F3, F2, F1

Question Number : 80 Question Id : 6589881400 Question Type : MCQ Option Shuffling : Yes Display Question Number : Yes  
Single Line Question Option : No Option Orientation : Vertical Allowed Progression : Yes Number of Replay : 999 Play On Load :  
No Control Enable : Yes

Correct Marks : 3 Wrong Marks : 1

Question Label : Multiple Choice Question

A three dimensional array in 'C' is declared as  $\text{int } A[x][y][z]$ . Here, the address of an item at the location  $A[p][q][r]$  can be computed as follows (where  $w$  is the word length of an integer) :

Options :

1.  $\&A[0][0][0]+w(y * z * q + z * p + r)$
2.  $\&A[0][0][0]+w(y * z * p + z * q + r)$
3.  $\&A[0][0][0]+w(x * y * p + z * q + r)$
4.  $\&A[0][0][0]+w(x * y * q + z * p + r)$

Question Number : 81 Question Id : 6589881401 Question Type : MCQ Option Shuffling : Yes Display Question Number : Yes  
Single Line Question Option : No Option Orientation : Vertical Allowed Progression : Yes Number of Replay : 999 Play On Load :  
No Control Enable : Yes

Correct Marks : 3 Wrong Marks : 1

Question Label : Multiple Choice Question

The worst case running times of Insertion sort, Merge sort and Quick sort, respectively, are :

Options :

1.  $\Theta(n \log n)$ ,  $\Theta(n \log n)$ , and  $\Theta(n^2)$
2.  $\Theta(n^2)$ ,  $\Theta(n^2)$ , and  $\Theta(n \log n)$
3.  $\Theta(n^2)$ ,  $\Theta(n \log n)$ , and  $\Theta(n \log n)$
4.  $\Theta(n^2)$ ,  $\Theta(n \log n)$ , and  $\Theta(n^2)$



Question Number : 82 Question Id : 6589881402 Question Type : MCQ Option Shuffling : Yes Display Question Number : Yes  
Single Line Question Option : No Option Orientation : Vertical Allowed Progression : Yes Number of Replay : 999 Play On Load :  
No Control Enable : Yes

Correct Marks : 3 Wrong Marks : 1

Question Label : Multiple Choice Question

In general, in a recursive and non-recursive implementation of a problem (program) :

Options :

1. Both time and space complexities are better in recursive than in non-recursive program.
2. Both time and space complexities are better in non-recursive than in recursive program.
3. Time complexity is better in recursive version but space complexity is better in non-recursive version of the program.
4. Space complexity is better in recursive version but time complexity is better in non-recursive version of the program.

Question Number : 83 Question Id : 6589881403 Question Type : MCQ Option Shuffling : Yes Display Question Number : Yes  
Single Line Question Option : No Option Orientation : Vertical Allowed Progression : Yes Number of Replay : 999 Play On Load :  
No Control Enable : Yes

Correct Marks : 3 Wrong Marks : 1

Question Label : Multiple Choice Question

Let  $G$  be a weighted connected undirected graph with distinct positive edge weights. If every edge weight is increased by the same value, then which of the following statements is/are TRUE ?

P : Minimum spanning tree of  $G$  does not change

Q : Shortest path between any pair of vertices does not change

Options :

1. P only
2. Q only
3. Neither P nor Q
4. Both P and Q

Question Number : 84 Question Id : 6589881404 Question Type : MCQ Option Shuffling : Yes Display Question Number : Yes  
Single Line Question Option : No Option Orientation : Vertical Allowed Progression : Yes Number of Replay : 999 Play On Load :  
No Control Enable : Yes

Correct Marks : 3 Wrong Marks : 1

Question Label : Multiple Choice Question

A queue is implemented using an array such that ENQUEUE and DEQUEUE operations are performed efficiently. Which one of the following statements is CORRECT ( $n$  refers to the number of items in the queue) ?

Options :

1. Both operations can be performed in  $O(1)$  time
2. At most one operation can be performed in  $O(1)$  time but the worst case time for the other operation will be  $\Omega(n)$
3. The worst case time complexity for both operations will be  $\Omega(n)$
4. Worst case time complexity for both operations will be  $\Omega(\log n)$

Question Number : 85 Question Id : 6589881405 Question Type : MCQ Option Shuffling : Yes Display Question Number : Yes Single Line Question Option : No Option Orientation : Vertical Allowed Progression : Yes Number of Replay : 999 Play On Load : No Control Enable : Yes

Correct Marks : 3 Wrong Marks : 1

Question Label : Multiple Choice Question

Consider the graph given below

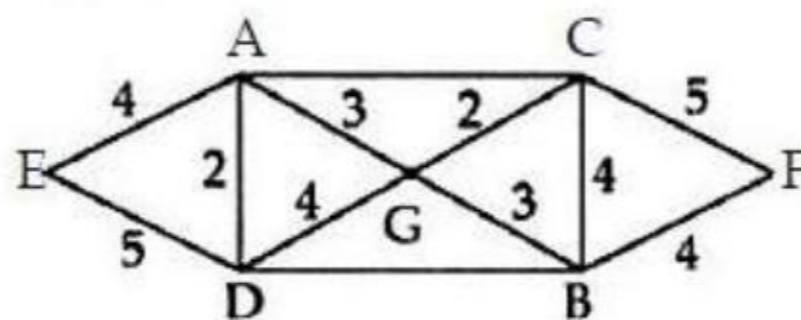

Use Kruskal's algorithm to find a minimal spanning tree for the graph. The List of the edges of the tree in the order in which they are chosen is? (1) AD, AE, AG, GC, GB, BF (2) GC, GB, BF, GA, AD, AE (3) GC, AD, GB, GA, BF, AE (4) AD, AG, GC, AE, GB, BF

Options :

1. (1)
2. (1),(2)
3. (1),(2),(3)
4. (1),(2),(3),(4)

Question Number : 86 Question Id : 6589881406 Question Type : MCQ Option Shuffling : Yes Display Question Number : Yes Single Line Question Option : No Option Orientation : Vertical Allowed Progression : Yes Number of Replay : 999 Play On Load : No Control Enable : Yes

Correct Marks : 3 Wrong Marks : 1

Question Label : Multiple Choice Question

How many swaps are required to sort the given array using bubble sort -  
{2, 5, 1, 3, 4} ?

Options :

1. 4
2. 5
3. 6
4. 7

Question Number : 87 Question Id : 6589881407 Question Type : MCQ Option Shuffling : Yes Display Question Number : Yes  
Single Line Question Option : No Option Orientation : Vertical Allowed Progression : Yes Number of Replay : 999 Play On Load :  
No Control Enable : Yes

Correct Marks : 3 Wrong Marks : 1

Question Label : Multiple Choice Question

The postfix form of  $A*B+C/D$  is :

Options :

1. ABCD + /\*
2. AB\*CD/+
3. \*AB/CD+
4. A\*BC+ /D

Question Number : 88 Question Id : 6589881408 Question Type : MCQ Option Shuffling : Yes Display Question Number : Yes  
Single Line Question Option : No Option Orientation : Vertical Allowed Progression : Yes Number of Replay : 999 Play On Load :  
No Control Enable : Yes

Correct Marks : 3 Wrong Marks : 1

Question Label : Multiple Choice Question

A program attempts to generate as many permutations as possible of the string, 'abcd' by pushing the characters a, b, c, d in the same order onto a stack, but it may pop off the top character at any time. Which one of the following strings CAN NOT be generated using this program ?

Options :

1. abcd
2. dcba
3. cbad

4. cabd

Question Number : 89 Question Id : 6589881409 Question Type : MCQ Option Shuffling : Yes Display Question Number : Yes  
Single Line Question Option : No Option Orientation : Vertical Allowed Progression : Yes Number of Replay : 999 Play On Load :  
No Control Enable : Yes

Correct Marks : 3 Wrong Marks : 1

Question Label : Multiple Choice Question

Consider the following pseudo code. What is the total number of multiplications to be performed ?

$D = 2$

for  $i = 1$  to  $n$  do

    for  $j = i$  to  $n$  do

        for  $k = j + 1$  to  $n$  do

$D = D * 3$

Options :

1. Half of the product of the 3 consecutive integers
2. One-third of the product of the 3 consecutive integers.
3. One-sixth of the product of the 3 consecutive integers.
4. None of the three

Question Number : 90 Question Id : 6589881410 Question Type : MCQ Option Shuffling : Yes Display Question Number : Yes  
Single Line Question Option : No Option Orientation : Vertical Allowed Progression : Yes Number of Replay : 999 Play On Load :  
No Control Enable : Yes

Correct Marks : 3 Wrong Marks : 1

Question Label : Multiple Choice Question

Consider a hash table with 9 slots. The hash function is  $h(k) = k \bmod 9$ . The collisions are resolved by chaining. The following 9 keys are inserted in the order: 5, 28, 19, 15, 20, 33, 12, 17, 10. The maximum, minimum, and average chain lengths in the hash table, respectively, are :

Options :

1. 3, 0 and 1
2. 3, 3 and 3
3. 4, 0 and 1

4. 3, 0 and 2

Question Number : 91 Question Id : 6589881411 Question Type : MCQ Option Shuffling : Yes Display Question Number : Yes  
Single Line Question Option : No Option Orientation : Vertical Allowed Progression : Yes Number of Replay : 999 Play On Load :  
No Control Enable : Yes

Correct Marks : 3 Wrong Marks : 1

Question Label : Multiple Choice Question

What will be output if you will compile and execute the following C language code ?

```
void main()  
{  
    printf("%s", "c " "question" "bank");  
}
```

Options :

1. c question bank
2. c
3. bank
4. cquestionbank

Question Number : 92 Question Id : 6589881412 Question Type : MCQ Option Shuffling : Yes Display Question Number : Yes  
Single Line Question Option : No Option Orientation : Vertical Allowed Progression : Yes Number of Replay : 999 Play On Load :  
No Control Enable : Yes

Correct Marks : 3 Wrong Marks : 1

Question Label : Multiple Choice Question

E-R modelling technique in DBMS is a :

Options :

1. top-down approach
2. bottom-up approach
3. left-right approach
4. none of the above

Question Number : 93 Question Id : 6589881413 Question Type : MCQ Option Shuffling : Yes Display Question Number : Yes  
Single Line Question Option : No Option Orientation : Vertical Allowed Progression : Yes Number of Replay : 999 Play On Load :  
No Control Enable : Yes

Correct Marks : 3 Wrong Marks : 1

Question Label : Multiple Choice Question

What would be the equivalent pointer expression for referring the array element a [i] [j] [k] [l] ?

Options :

1.  $(((((a+i)+j)+k)+l))$
2.  $((((a+i)+j)+k+1)$
3.  $((a+i)+j+k+1)$
4.  $(*((*(*(a+i)+j)+k)+1)$

Question Number : 94 Question Id : 6589881414 Question Type : MCQ Option Shuffling : Yes Display Question Number : Yes  
Single Line Question Option : No Option Orientation : Vertical Allowed Progression : Yes Number of Replay : 999 Play On Load :  
No Control Enable : Yes

Correct Marks : 3 Wrong Marks : 1

Question Label : Multiple Choice Question

In C, if you pass an array as an argument to a function, what actually gets passed ?

Options :

1. Value of elements in array
2. First element of the array
3. Base address of the array
4. Address of the last element of array

Question Number : 95 Question Id : 6589881415 Question Type : MCQ Option Shuffling : Yes Display Question Number : Yes  
Single Line Question Option : No Option Orientation : Vertical Allowed Progression : Yes Number of Replay : 999 Play On Load :  
No Control Enable : Yes

Correct Marks : 3 Wrong Marks : 1

Question Label : Multiple Choice Question

FTP server listens for connection on port number :

Options :

1. 20
2. 21
3. 22
4. 23

Question Number : 96 Question Id : 6589881416 Question Type : MCQ Option Shuffling : Yes Display Question Number : Yes  
Single Line Question Option : No Option Orientation : Vertical Allowed Progression : Yes Number of Replay : 999 Play On Load :  
No Control Enable : Yes

Correct Marks : 3 Wrong Marks : 1

Question Label : Multiple Choice Question

A dynamic Webpage :

Options :

1. is same every time whenever it is displayed.
2. is generated on demand by a program or a request from browser
3. is same every time whenever it is displayed and is generated on demand by a program or a request from browser
4. remains same all the time

Question Number : 97 Question Id : 6589881417 Question Type : MCQ Option Shuffling : Yes Display Question Number : Yes  
Single Line Question Option : No Option Orientation : Vertical Allowed Progression : Yes Number of Replay : 999 Play On Load :  
No Control Enable : Yes

Correct Marks : 3 Wrong Marks : 1

Question Label : Multiple Choice Question

CMOS stands for :

Options :

1. Common Metal Oxide Semiconductor
2. Common Mono Oxide Semiconductor
3. Common Metal Oxide Superconductor
4. Complementary Metal Oxide Semiconductor

Question Number : 98 Question Id : 6589881418 Question Type : MCQ Option Shuffling : Yes Display Question Number : Yes  
Single Line Question Option : No Option Orientation : Vertical Allowed Progression : Yes Number of Replay : 999 Play On Load :  
No Control Enable : Yes

Correct Marks : 3 Wrong Marks : 1

Question Label : Multiple Choice Question

Identify the correct order in which the following actions take place in an interaction between a web browser and a web server :

- A. The web browser requests a webpage using HTTP.
- B. The web browser establishes a TCP connection with the web server.
- C. The web server sends the requested webpage using HTTP.
- D. The web browser resolves the domain name using DNS.

Options :

1. D, B, A, C
2. A, B, C, D

3. D, A, B, C

4. B, D, A, C

Question Number : 99 Question Id : 6589881419 Question Type : MCQ Option Shuffling : Yes Display Question Number : Yes  
Single Line Question Option : No Option Orientation : Vertical Allowed Progression : Yes Number of Replay : 999 Play On Load :  
No Control Enable : Yes

Correct Marks : 3 Wrong Marks : 1

Question Label : Multiple Choice Question

A HTML form is to be designed to enable purchase of office stationery. Required items are to be selected (checked). Credit card details are to be entered and then the submit button is to be pressed. Which one of the following options would be appropriate for sending the data to the server. Assume that security is handled in a way that is transparent to the form design.

Options :

1. Only GET

2. Only POST

3. Either of GET or POST

4. Neither GET nor POST

Question Number : 100 Question Id : 6589881420 Question Type : MCQ Option Shuffling : Yes Display Question Number : Yes  
Single Line Question Option : No Option Orientation : Vertical Allowed Progression : Yes Number of Replay : 999 Play On Load :  
No Control Enable : Yes

Correct Marks : 3 Wrong Marks : 1

Question Label : Multiple Choice Question

Which mode loads minimal set of drivers when starting Windows ?

Options :

1. Safe mode

2. Normal mode

3. VGA mode

4. Network support mode

Question Number : 101 Question Id : 6589881421 Question Type : MCQ Option Shuffling : Yes Display Question Number : Yes  
Single Line Question Option : No Option Orientation : Vertical Allowed Progression : Yes Number of Replay : 999 Play On Load :  
No Control Enable : Yes

Correct Marks : 3 Wrong Marks : 1

Question Label : Multiple Choice Question



The set of tracks on a disk which can be accessed without repositioning the R/W heads constitute :

Options :

1. Surface
2. Cylinder
3. Cluster
4. Driver

Question Number : 102 Question Id : 6589881422 Question Type : MCQ Option Shuffling : Yes Display Question Number : Yes Single Line Question Option : No Option Orientation : Vertical Allowed Progression : Yes Number of Replay : 999 Play On Load : No Control Enable : Yes

Correct Marks : 3 Wrong Marks : 1

Question Label : Multiple Choice Question

A pointer is a :

Options :

1. A keyword used to create variables
2. A variable that stores address of an instruction
3. A variable that stores address of other variable
4. A keyword used to create address

Question Number : 103 Question Id : 6589881423 Question Type : MCQ Option Shuffling : Yes Display Question Number : Yes Single Line Question Option : No Option Orientation : Vertical Allowed Progression : Yes Number of Replay : 999 Play On Load : No Control Enable : Yes

Correct Marks : 3 Wrong Marks : 1

Question Label : Multiple Choice Question

What will be output if you will compile and execute the following C language code ?

```
struct marks{
int p : 3;
int c : 3;
int m : 2;
};
void main(){
struct marks s={2,-6, 5};
printf("%d %d %d",s.p, s.c, s.m);
}
```

Options :

1. 2 -6 5

2. 2 - 6 1
3. 2 2 1
4. Compiler error

Question Number : 104 Question Id : 6589881424 Question Type : MCQ Option Shuffling : Yes Display Question Number : Yes  
Single Line Question Option : No Option Orientation : Vertical Allowed Progression : Yes Number of Replay : 999 Play On Load :  
No Control Enable : Yes

Correct Marks : 3 Wrong Marks : 1

Question Label : Multiple Choice Question

What will be output if you will compile and execute the following C language code ?

```
void main()
{
    int i = 10;
    static int x=i;
    if(x==i)
        printf("Equal ");
    else if(x>i)
        printf("Greater than ");
    else
        printf("Less than ");
}
```

Options :

1. Equal
2. Greater than
3. Less than
4. Compiler error

Question Number : 105 Question Id : 6589881425 Question Type : MCQ Option Shuffling : Yes Display Question Number : Yes  
Single Line Question Option : No Option Orientation : Vertical Allowed Progression : Yes Number of Replay : 999 Play On Load :  
No Control Enable : Yes

Correct Marks : 3 Wrong Marks : 1

Question Label : Multiple Choice Question

What will be output if you will compile and execute the following C language code ?

```
void main()
{
int i;
float a = 5.2;
char *ptr;
ptr=(char *)&a;
for(i=0; i<=3; i++)
printf("%d ", *ptr++);
}
```

Options :

1. 0 0 0 0
2. 102 56 -80 32
3. 102 102 -90 64
4. Garbage Garbage Garbage Garbage

Question Number : 106 Question Id : 6589881426 Question Type : MCQ Option Shuffling : Yes Display Question Number : Yes  
Single Line Question Option : No Option Orientation : Vertical Allowed Progression : Yes Number of Replay : 999 Play On Load :  
No Control Enable : Yes

Correct Marks : 3 Wrong Marks : 1

Question Label : Multiple Choice Question

What will be output if you will compile and execute the following C language code ?

```
#include "string.h"
void main()
{
clrscr();
printf("%d %d",sizeof("string"),strlen("string"));
getch();
}
```

Options :

1. 6 6
2. 7 7
3. 6 7

4. 76

Question Number : 107 Question Id : 6589881427 Question Type : MCQ Option Shuffling : Yes Display Question Number : Yes  
Single Line Question Option : No Option Orientation : Vertical Allowed Progression : Yes Number of Replay : 999 Play On Load :  
No Control Enable : Yes

Correct Marks : 3 Wrong Marks : 1

Question Label : Multiple Choice Question

What will be output if you will compile and execute the following C language code segment ?

```
int extern x;  
void main()  
{  
printf("%d",x);  
x = 2;  
getch();  
}  
int x=23;
```

Options :

1. 0
2. 2
3. 23
4. Compiler error

Question Number : 108 Question Id : 6589881428 Question Type : MCQ Option Shuffling : Yes Display Question Number : Yes  
Single Line Question Option : No Option Orientation : Vertical Allowed Progression : Yes Number of Replay : 999 Play On Load :  
No Control Enable : Yes

Correct Marks : 3 Wrong Marks : 1

Question Label : Multiple Choice Question

What will be output if you will compile and execute the following C language code ?

```
void main()  
{  
if(printf("I am from CC"))  
printf("I know c");  
else  
printf("I know c++");  
}
```

Options :

1. I know c
2. I know c++
3. I am from CCI know c
4. I am from CCI know c++

Question Number : 109 Question Id : 6589881429 Question Type : MCQ Option Shuffling : Yes Display Question Number : Yes  
Single Line Question Option : No Option Orientation : Vertical Allowed Progression : Yes Number of Replay : 999 Play On Load :  
No Control Enable : Yes

Correct Marks : 3 Wrong Marks : 1

Question Label : Multiple Choice Question

What will be output if you will compile and execute the following C language code ?

```
int main()
{
    char *ptr;
    char string[] = "Learn C from Computer Center";

    ptr += 6;
    printf("%s", ptr);
    return 0;
}
```

Options :

1. Compilation Error
2. Runtime Error
3. C from Computer Center
4. from Computer Center

Question Number : 110 Question Id : 6589881430 Question Type : MCQ Option Shuffling : Yes Display Question Number : Yes  
Single Line Question Option : No Option Orientation : Vertical Allowed Progression : Yes Number of Replay : 999 Play On Load :  
No Control Enable : Yes

Correct Marks : 3 Wrong Marks : 1

Question Label : Multiple Choice Question

What will be output if you will compile and execute the following C language code ?

```
int main()
{
int a = 5;
int *ptr;
ptr = &a;
*ptr = 10;
printf("%d",a);
return 0;
}
```

Options :

1. Compilation Error
2. Garbage value
3. 5
4. 10

Question Number : 111 Question Id : 6589881431 Question Type : MCQ Option Shuffling : Yes Display Question Number : Yes  
Single Line Question Option : No Option Orientation : Vertical Allowed Progression : Yes Number of Replay : 999 Play On Load :  
No Control Enable : Yes

Correct Marks : 3 Wrong Marks : 1

Question Label : Multiple Choice Question

What will be output if you will compile and execute the following C language code ?

```
void function(char**);  
  
int main()  
{  
    char *arr[] = { "ant", "bat", "cat", "dog", "egg", "fly" };  
    function(arr);  
    return 0;  
}  
  
void function(char **ptr)  
{  
    char *ptr1;  
    ptr1 = (ptr += sizeof(int))[-2];  
    printf("%s\n", ptr1);  
}
```

Options :

1. bat
2. cat
3. dog
4. egg

Question Number : 112 Question Id : 6589881432 Question Type : MCQ Option Shuffling : Yes Display Question Number : Yes  
Single Line Question Option : No Option Orientation : Vertical Allowed Progression : Yes Number of Replay : 999 Play On Load :  
No Control Enable : Yes

Correct Marks : 3 Wrong Marks : 1

Question Label : Multiple Choice Question

What will be output of the following C program ?

```
#include<stdio.h>

int main()
{
long int 1a=51;
printf("%ld",1a);
return 0;
}
```

Options :

1. 5
2. 51
3. 6
4. Compile error

Question Number : 113 Question Id : 6589881433 Question Type : MCQ Option Shuffling : Yes Display Question Number : Yes  
Single Line Question Option : No Option Orientation : Vertical Allowed Progression : Yes Number of Replay : 999 Play On Load :  
No Control Enable : Yes

Correct Marks : 3 Wrong Marks : 1

Question Label : Multiple Choice Question

What is meant by following :

- X. (\*x)[10] and  
Y. \*x[10]

Options :

1. X represents pointer to an array and Y represents array of pointers
2. Y represents pointer to an array and X represents array of pointers
3. X and Y are same
4. X and Y both are incorrect statements

Question Number : 114 Question Id : 6589881434 Question Type : MCQ Option Shuffling : Yes Display Question Number : Yes  
Single Line Question Option : No Option Orientation : Vertical Allowed Progression : Yes Number of Replay : 999 Play On Load :  
No Control Enable : Yes

Correct Marks : 3 Wrong Marks : 1

Question Label : Multiple Choice Question



A C program contains the following declaration :

```
static float table[2][3] = {  
    {1.1, 1.2, 1.3},  
    {2.1, 2.2, 2.3}  
}
```

What is the value of `*(*(table+1)+1)`

Options :

1. 1.2
2. 2.2
3. 2.3
4. None of the above

Question Number : 115 Question Id : 6589881435 Question Type : MCQ Option Shuffling : Yes Display Question Number : Yes  
Single Line Question Option : No Option Orientation : Vertical Allowed Progression : Yes Number of Replay : 999 Play On Load :  
No Control Enable : Yes

Correct Marks : 3 Wrong Marks : 1

Question Label : Multiple Choice Question

What will be output of the following program :

```
int main()  
{  
    int a = 15, b;  
    b = (a++) + (a++);  
    a = (b++) + (b++);  
    printf("a=%d b=%d", a, b);  
    return (0);  
}
```

Options :

1. a = 63, b = 33
2. a = 33, b = 63
3. a = 66, b = 33
4. a = 33, b = 33

Question Number : 116 Question Id : 6589881436 Question Type : MCQ Option Shuffling : Yes Display Question Number : Yes  
Single Line Question Option : No Option Orientation : Vertical Allowed Progression : Yes Number of Replay : 999 Play On Load :  
No Control Enable : Yes

Correct Marks : 3 Wrong Marks : 1

Question Label : Multiple Choice Question

What will be output of the following program :

```
#define square(x) (x * x)
```

```
int main()
```

```
{
```

```
    int x, y = 1;
```

```
    x = square(y + 1);
```

```
    printf("%d\n", x);
```

```
    return 0;
```

```
}
```

Options :

1. Error
2. 4
3. 3
4. Garbage value

Question Number : 117 Question Id : 6589881437 Question Type : MCQ Option Shuffling : Yes Display Question Number : Yes  
Single Line Question Option : No Option Orientation : Vertical Allowed Progression : Yes Number of Replay : 999 Play On Load :  
No Control Enable : Yes

Correct Marks : 3 Wrong Marks : 1

Question Label : Multiple Choice Question

In the absence of an exit condition in a recursive function, the following error is

given .....

Options :

1. Compile time error
2. Run time error
3. Logical error
4. No error

Question Number : 118 Question Id : 6589881438 Question Type : MCQ Option Shuffling : Yes Display Question Number : Yes  
Single Line Question Option : No Option Orientation : Vertical Allowed Progression : Yes Number of Replay : 999 Play On Load :  
No Control Enable : Yes

Correct Marks : 3 Wrong Marks : 1

Question Label : Multiple Choice Question

According to ANSI specification which is the correct way of declaring main when it receives command-line arguments ?

Options :

1. `int main(int argc, char *argv[])`
2. `int main(argc, argv)`
3. `int argc; char *argv;`
4. `void main(float argc, char *argv[])`

Question Number : 119 Question Id : 6589881439 Question Type : MCQ Option Shuffling : Yes Display Question Number : Yes  
Single Line Question Option : No Option Orientation : Vertical Allowed Progression : Yes Number of Replay : 999 Play On Load :  
No Control Enable : Yes

Correct Marks : 3 Wrong Marks : 1

Question Label : Multiple Choice Question

What does fp point to in the program ?

```
#include<stdio.h>

int main()
{
    FILE *fp;
    fp=fopen("trial", "r");
    return 0;
}
```

Options :

1. The first character in the file
2. The name of the file.
3. The last character in the file.
4. Number

Question Number : 120 Question Id : 6589881440 Question Type : MCQ Option Shuffling : Yes Display Question Number : Yes  
Single Line Question Option : No Option Orientation : Vertical Allowed Progression : Yes Number of Replay : 999 Play On Load :  
No Control Enable : Yes

Correct Marks : 3 Wrong Marks : 1

Question Label : Multiple Choice Question

A C variable name can start with a/an .....

Options :

1. Number
2. Plus Sign (+)
3. Underscore ( \_ )
4. Asterisk (\*)