

National Testing Agency

Question Paper Name :	BTECH E 4th Sep 2020 Shift 1
Subject Name :	BTECH E
Creation Date :	2020-09-04 15:20:24
Duration :	180
Total Marks :	300
Display Marks:	Yes
Share Answer Key With Delivery Engine :	Yes
Actual Answer Key :	Yes

BTECH

Group Number :	1
Group Id :	405036122
Group Maximum Duration :	0
Group Minimum Duration :	180
Show Attended Group? :	No
Edit Attended Group? :	No
Break time :	0
Group Marks :	300
Is this Group for Examiner? :	No

Physics

Section Id :	405036406
Section Number :	1
Section type :	Online
Mandatory or Optional :	Mandatory
Number of Questions :	25

Number of Questions to be attempted :	25
Section Marks :	100
Display Number Panel :	Yes
Group All Questions :	Yes
Mark As Answered Required? :	Yes
Sub-Section Number :	1
Sub-Section Id :	405036779
Question Shuffling Allowed :	Yes

Question Number : 1 Question Id : 40503611156 Question Type : MCQ Option Shuffling : Yes Display Question Number : Yes Is Question Mandatory : No Single Line Question Option : No Option Orientation : Vertical Correct Marks : 4 Wrong Marks : 1

Dimensional formula for thermal conductivity is (here K denotes the temperature) :

Options :

40503640521. $MLT^{-2}K$

40503640522. $MLT^{-3}K^{-1}$

40503640523. $MLT^{-3}K$

40503640524. $MLT^{-2}K^{-2}$

Question Number : 1 Question Id : 40503611156 Question Type : MCQ Option Shuffling : Yes Display Question Number : Yes Is Question Mandatory : No Single Line Question Option : No Option Orientation : Vertical Correct Marks : 4 Wrong Marks : 1

तापीय चालकता के लिये विमिय सूत्र (dimensional formula) होगा (यहाँ पर K तापमान दर्शाता है) :

Options :

40503640521. $MLT^{-2} K$

40503640522. $MLT^{-3} K^{-1}$

40503640523. $MLT^{-3} K$

40503640524. $MLT^{-2} K^{-2}$

Question Number : 2 Question Id : 40503611157 Question Type : MCQ Option Shuffling : Yes Display Question Number : Yes Is Question Mandatory : No Single Line Question Option : No Option Orientation : Vertical

Correct Marks : 4 Wrong Marks : 1

A Tennis ball is released from a height h and after freely falling on a wooden floor

it rebounds and reaches height $\frac{h}{2}$. The

velocity versus height of the ball during its motion may be represented graphically by :

(graph are drawn schematically and on not to scale)

Options :

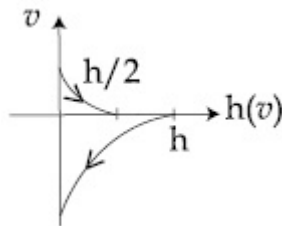

40503640525.

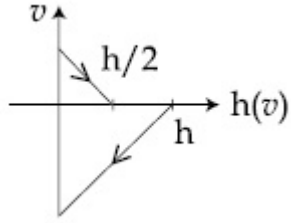

40503640526.

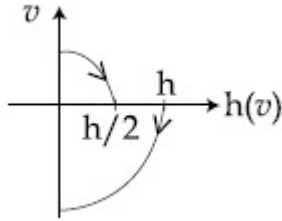

40503640527.

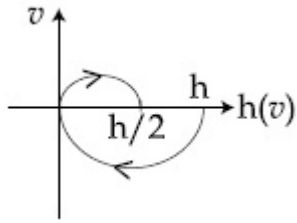

40503640528.

Question Number : 2 Question Id : 40503611157 Question Type : MCQ Option Shuffling : Yes Display Question Number : Yes Is Question Mandatory : No Single Line Question Option : No Option Orientation : Vertical

Correct Marks : 4 Wrong Marks : 1

एक टेनिस गेंद h ऊँचाई से छोड़ी जाती है और स्वतन्त्र

रूप से एक लकड़ी के फर्श पर टकराकर यह $\frac{h}{2}$

ऊँचाई तक पहुँचती है। इसके लिये गति के दौरान गेंद के वेग और ऊँचाई के बीच सम्बंध निम्न में से किस

ग्राफ द्वारा दिखाया जाता है :

(ग्राफ संकेतात्मक हैं)

Options :

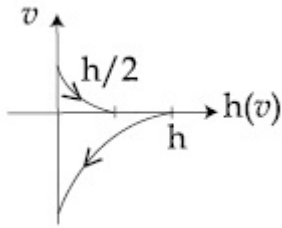

40503640525.

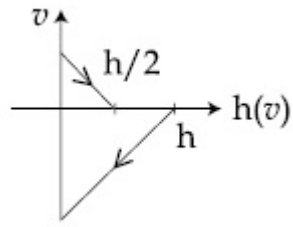

40503640526.

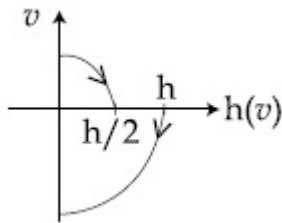

40503640527.

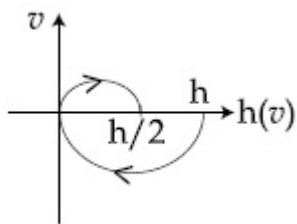

40503640528.

Question Number : 3 Question Id : 40503611158 Question Type : MCQ Option Shuffling : Yes Display Question Number : Yes Is Question Mandatory : No Single Line Question Option : No Option Orientation : Vertical Correct Marks : 4 Wrong Marks : 1

Starting from the origin at time $t=0$, with initial velocity $5\hat{j} \text{ ms}^{-1}$, a particle moves in the $x-y$ plane with a constant acceleration of $(10\hat{i} + 4\hat{j}) \text{ ms}^{-2}$. At time t , its coordinates are $(20 \text{ m}, y_0 \text{ m})$. The values of t and y_0 are, respectively :

Options :

40503640529. 2 s and 24 m

40503640530. 4 s and 52 m

40503640531. 2 s and 18 m

40503640532. 5 s and 25 m

Question Number : 3 Question Id : 40503611158 Question Type : MCQ Option Shuffling : Yes Display Question Number : Yes Is

Question Mandatory : No Single Line Question Option : No Option Orientation : Vertical

Correct Marks : 4 Wrong Marks : 1

समय $t=0$ पर मूल बिन्दु से प्रारम्भिक वेग $5\hat{j} \text{ ms}^{-1}$

व त्वरण $(10\hat{i} + 4\hat{j}) \text{ ms}^{-2}$ के साथ शुरू होकर

एक कण $x-y$ समतल पर चल रहा है। समय t पर यह बिन्दु $(20 \text{ m}, y_0 \text{ m})$ पर है। क्रमशः समय t और y_0 के मान हैं :

Options :

40503640529. 2 s और 24 m

40503640530. 4 s और 52 m

40503640531. 2 s और 18 m

40503640532. 5 s और 25 m

Question Number : 4 Question Id : 40503611159 Question Type : MCQ Option Shuffling : Yes Display Question Number : Yes Is Question Mandatory : No Single Line Question Option : No Option Orientation : Vertical

Correct Marks : 4 Wrong Marks : 1

Blocks of masses m , $2m$, $4m$ and $8m$ are arranged in a line on a frictionless floor. Another block of mass m , moving with speed v along the same line (see figure) collides with mass m in perfectly inelastic manner. All the subsequent collisions are also perfectly inelastic. By the time the last block of mass $8m$ starts moving the total energy loss is $p\%$ of the original energy. Value of ' p ' is close to :

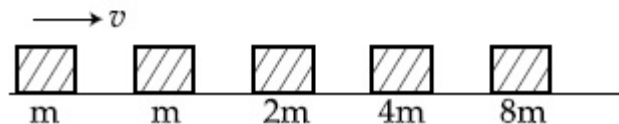

Options :

40503640533. 37

40503640534. 77

40503640535. 87

40503640536. 94

Question Number : 4 Question Id : 40503611159 Question Type : MCQ Option Shuffling : Yes Display Question Number : Yes Is Question Mandatory : No Single Line Question Option : No Option Orientation : Vertical

Correct Marks : 4 Wrong Marks : 1

द्रव्यमान m , $2m$, $4m$ और $8m$ के गुटके एक घर्षण रहित फर्श पर एक सीधी रेखा पर रखे हुए हैं। द्रव्यमान m का एक गुटका इसी रेखा पर v गति से चलते हुए m द्रव्यमान के गुटके से पूर्णतः अप्रत्यास्थ टक्कर करता है (चित्र देखें) इसके बाद होने वाली सभी टक्करें भी पूर्णतः अप्रत्यास्थ हैं। इस प्रकार जब तक $8m$ द्रव्यमान का गुटका चलना शुरू करता है तब तक मूल ऊर्जा की $p\%$ ऊर्जा की क्षति हो चुकी होती है। 'p' का निकटतम मान है :

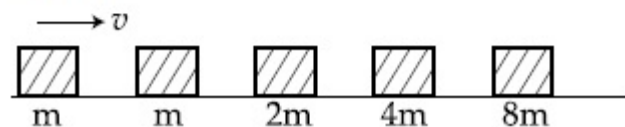

Options :

40503640533. 37

40503640534. 77

40503640535. 87

Question Number : 5 Question Id : 40503611160 Question Type : MCQ Option Shuffling : Yes Display Question Number : Yes Is Question Mandatory : No Single Line Question Option : No Option Orientation : Vertical

Correct Marks : 4 Wrong Marks : 1

On the x -axis and at a distance x from the origin, the gravitational field due to a mass

distribution is given by $\frac{Ax}{(x^2 + a^2)^{3/2}}$ in the

x -direction. The magnitude of gravitational potential on the x -axis at a distance x , taking its value to be zero at infinity, is :

Options :

40503640537. $\frac{A}{(x^2 + a^2)^{3/2}}$

40503640538. $\frac{A}{(x^2 + a^2)^{1/2}}$

40503640539. $A(x^2 + a^2)^{3/2}$

40503640540. $A(x^2 + a^2)^{1/2}$

Question Mandatory : No Single Line Question Option : No Option Orientation : Vertical

Correct Marks : 4 Wrong Marks : 1

x -अक्ष पर और मूलबिन्दु से x दूरी पर एक वितरित द्रव्यमान से उत्पन्न होने वाला गुरुत्वीय क्षेत्र

$\frac{Ax}{(x^2 + a^2)^{3/2}}$ x -दिशा में है। x -अक्ष पर मूल बिन्दु

से x दूरी पर गुरुत्वीय विभव का परिमाण (इसे $x = \infty$ पर शून्य मानकर) होगा :

Options :

40503640537. $\frac{A}{(x^2 + a^2)^{3/2}}$

40503640538. $\frac{A}{(x^2 + a^2)^{1/2}}$

40503640539. $A(x^2 + a^2)^{3/2}$

40503640540. $A(x^2 + a^2)^{1/2}$

Question Number : 6 Question Id : 40503611161 Question Type : MCQ Option Shuffling : Yes Display Question Number : Yes Is

Question Mandatory : No Single Line Question Option : No Option Orientation : Vertical

Correct Marks : 4 Wrong Marks : 1

A air bubble of radius 1 cm in water has an upward acceleration 9.8 cm s^{-2} . The density of water is 1 gm cm^{-3} and water offers negligible drag force on the bubble. The mass of the bubble is ($g = 980 \text{ cm/s}^2$).

Options :

40503640541. 1.52 gm

40503640542. 3.15 gm

40503640543. 4.15 gm

40503640544. 4.51 gm

Question Number : 6 Question Id : 40503611161 Question Type : MCQ Option Shuffling : Yes Display Question Number : Yes Is Question Mandatory : No Single Line Question Option : No Option Orientation : Vertical

Correct Marks : 4 Wrong Marks : 1

त्रिज्या 1 cm का एक वायु का बुलबुला पानी में ऊपर की ओर 9.8 cm s^{-2} त्वरण से चल रहा है। पानी का घनत्व 1 gm cm^{-3} है और बुलबुले पर पानी द्वारा लगने वाला कर्षण बल नगण्य है। बुलबुले का द्रव्यमान है ($g = 980 \text{ cm/s}^2$) :

Options :

40503640541. 1.52 gm

40503640542. 3.15 gm

40503640543. 4.15 gm

40503640544. 4.51 gm

Question Number : 7 Question Id : 40503611162 Question Type : MCQ Option Shuffling : Yes Display Question Number : Yes Is Question Mandatory : No Single Line Question Option : No Option Orientation : Vertical

Correct Marks : 4 Wrong Marks : 1

The specific heat of water = $4200 \text{ J kg}^{-1}\text{K}^{-1}$ and the latent heat of ice = $3.4 \times 10^5 \text{ J kg}^{-1}$. 100 grams of ice at 0°C is placed in 200 g of water at 25°C . The amount of ice that will melt as the temperature of water reaches 0°C is close to (in grams) :

Options :

40503640545. 69.3

40503640546. 61.7

40503640547. 64.6

40503640548. 63.8

Question Number : 7 Question Id : 40503611162 Question Type : MCQ Option Shuffling : Yes Display Question Number : Yes Is Question Mandatory : No Single Line Question Option : No Option Orientation : Vertical

Correct Marks : 4 Wrong Marks : 1

पानी की विशिष्ट ऊष्मा = $4200 \text{ J kg}^{-1} \text{ K}^{-1}$ तथा बर्फ के पिघलने की गुप्त ऊष्मा = $3.4 \times 10^5 \text{ J kg}^{-1}$ है। 0°C की 100 g बर्फ को 25°C के 200 g पानी में डाला जाता है। जब पानी 0°C पर आता है तो बर्फ की कितनी मात्रा (ग्राम में) पिघल जायेगी?

Options :

40503640545. 69.3

40503640546. 61.7

40503640547. 64.6

40503640548. 63.8

Question Number : 8 Question Id : 40503611163 Question Type : MCQ Option Shuffling : Yes Display Question Number : Yes Is Question Mandatory : No Single Line Question Option : No Option Orientation : Vertical

Correct Marks : 4 Wrong Marks : 1

Match the C_p/C_v ratio for ideal gases with different type of molecules :

Molecule Type	C_p/C_v
(A) Monatomic	(I) 7/5
(B) Diatomic rigid molecules	(II) 9/7
(C) Diatomic non-rigid molecules	(III) 4/3
(D) Triatomic rigid molecules	(IV) 5/3

Options :

40503640549. (A)-(IV), (B)-(I), (C)-(II), (D)-(III)

40503640550. (A)-(IV), (B)-(II), (C)-(I), (D)-(III)

40503640551. (A)-(III), (B)-(IV), (C)-(II), (D)-(I)

40503640552. (A)-(II), (B)-(III), (C)-(I), (D)-(IV)

Question Number : 8 Question Id : 40503611163 Question Type : MCQ Option Shuffling : Yes Display Question Number : Yes Is Question Mandatory : No Single Line Question Option : No Option Orientation : Vertical Correct Marks : 4 Wrong Marks : 1

भिन्न-भिन्न अणुओं से बनी आदर्श गैसे के लिये नीचे दी गयी सारिणी से अणु के प्रकार और गैस के C_p/C_v अनुपात का मेल करें :

अणु के प्रकार	C_p/C_v
(A) एक परमाणुक	(I) 7/5
(B) द्वि परमाणुक, दृढ़ अणु	(II) 9/7
(C) द्वि परमाणुक, अदृढ़ अणु	(III) 4/3
(D) त्रि परमाणुक, दृढ़ अणु	(IV) 5/3

Options :

40503640549. (A)-(IV), (B)-(I), (C)-(II), (D)-(III)

40503640550. (A)-(IV), (B)-(II), (C)-(I), (D)-(III)

40503640551. (A)-(III), (B)-(IV), (C)-(II), (D)-(I)

40503640552. (A)-(II), (B)-(III), (C)-(I), (D)-(IV)

Question Number : 9 Question Id : 40503611164 Question Type : MCQ Option Shuffling : Yes Display Question Number : Yes Is Question Mandatory : No Single Line Question Option : No Option Orientation : Vertical

Correct Marks : 4 Wrong Marks : 1

For a transverse wave travelling along a straight line, the distance between two peaks (crests) is 5 m, while the distance between one crest and one trough is 1.5 m. The possible wavelengths (in m) of the waves are :

Options :

40503640553. 1, 2, 3,

40503640554. 1, 3, 5,

40503640555. $\frac{1}{1}$, $\frac{1}{3}$, $\frac{1}{5}$,

40503640556. $\frac{1}{2}$, $\frac{1}{4}$, $\frac{1}{6}$,

Question Number : 9 Question Id : 40503611164 Question Type : MCQ Option Shuffling : Yes Display Question Number : Yes Is Question Mandatory : No Single Line Question Option : No Option Orientation : Vertical

Correct Marks : 4 Wrong Marks : 1

एक सीधी रेखा पर चलने वाली एक अनुप्रस्थ तरंग के दो शीर्षों के बीच की दूरी 5 m है जबकि इसके एक शीर्ष और एक गर्त के बीच की दूरी 1.5 m है। तरंग के संभावित तरंगदैर्घ्यों के मीटर में मान हैं :

Options :

40503640553. 1, 2, 3,

40503640554. 1, 3, 5,

40503640555. $\frac{1}{1'}, \frac{1}{3'}, \frac{1}{5'}, \dots$

40503640556. $\frac{1}{2'}, \frac{1}{4'}, \frac{1}{6'}, \dots$

Question Number : 10 Question Id : 40503611165 Question Type : MCQ Option Shuffling : Yes Display Question Number : Yes Is Question Mandatory : No Single Line Question Option : No Option Orientation : Vertical

Correct Marks : 4 Wrong Marks : 1

Two charged thin infinite plane sheets of uniform surface charge density σ_+ and σ_- , where $|\sigma_+| > |\sigma_-|$, intersect at right angle. Which of the following best represents the electric field lines for this system :

Options :

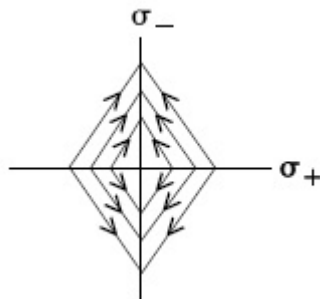

40503640557.

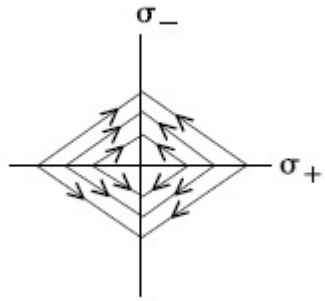

40503640558.

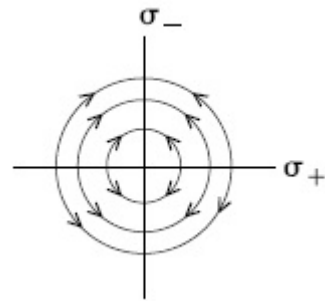

40503640559.

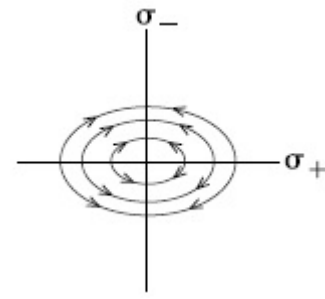

40503640560.

Question Number : 10 Question Id : 40503611165 Question Type : MCQ Option Shuffling : Yes Display Question Number : Yes Is Question Mandatory : No Single Line Question Option : No Option Orientation : Vertical Correct Marks : 4 Wrong Marks : 1

दो अनन्त लम्बाई-चौड़ाई की पतली चादरों पर एकसमान सतह घनत्व σ_+ और σ_- का आवेश वितरित है $|\sigma_+| > |\sigma_-|$ ये चादरें एक दूसरे के लम्बवत् हैं। ऐसी स्थिति में निम्न में से कौन सा चित्र इस निकाय का विद्युत क्षेत्र प्रदर्शित करता है :

Options :

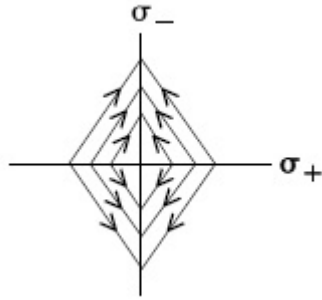

40503640557.

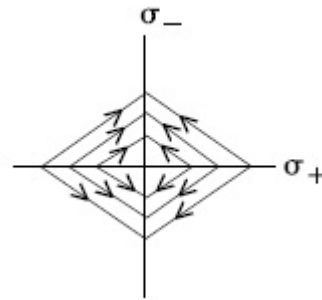

40503640558.

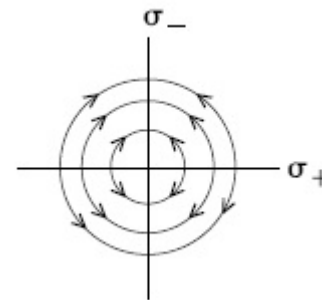

40503640559.

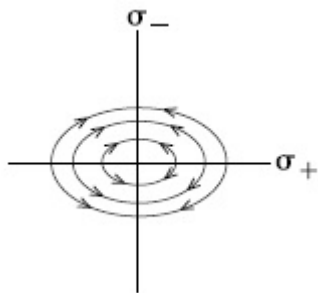

40503640560.

Question Number : 11 Question Id : 40503611166 Question Type : MCQ Option Shuffling : Yes Display Question Number : Yes Is Question Mandatory : No Single Line Question Option : No Option Orientation : Vertical

Correct Marks : 4 Wrong Marks : 1

A two point charges $4q$ and $-q$ are fixed on the x -axis at $x = -\frac{d}{2}$ and $x = \frac{d}{2}$, respectively. If a third point charge ' q ' is taken from the origin to $x = d$ along the semicircle as shown in the figure, the energy of the charge will :

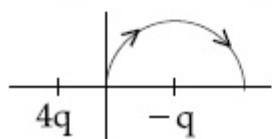

Options :

decrease by $\frac{q^2}{4\pi\epsilon_0 d}$

40503640561.

increase by $\frac{3q^2}{4\pi\epsilon_0 d}$

40503640562.

40503640563. decrease by $\frac{4q^2}{3\pi\epsilon_0 d}$

40503640564. increase by $\frac{2q^2}{3\pi\epsilon_0 d}$

Question Number : 11 Question Id : 40503611166 Question Type : MCQ Option Shuffling : Yes Display Question Number : Yes Is Question Mandatory : No Single Line Question Option : No Option Orientation : Vertical Correct Marks : 4 Wrong Marks : 1

दो बिन्दु आवेश $4q$ और $-q$ x -अक्ष पर क्रमशः

$x = -\frac{d}{2}$ व $x = \frac{d}{2}$ पर रखे हुए हैं। यदि एक

तीसरा बिन्दु आवेश ' q ' को मूल बिन्दु से $x=d$ पर चित्र में दिखाये अर्द्धवृत्त पर ले जाया जाये तो इस आवेश की ऊर्जा :

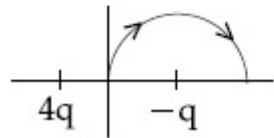

Options :

40503640561. $\frac{q^2}{4\pi\epsilon_0 d}$ मात्रा से घटेगी

40503640562. $\frac{3q^2}{4\pi\epsilon_0 d}$ मात्रा से बढ़ेगी

40503640563. $\frac{4q^2}{3\pi\epsilon_0 d}$ मात्रा से घटेगी

40503640564. $\frac{2q^2}{3\pi\epsilon_0 d}$ मात्रा से बढ़ेगी

Question Number : 12 Question Id : 40503611167 Question Type : MCQ Option Shuffling : Yes Display Question Number : Yes Is Question Mandatory : No Single Line Question Option : No Option Orientation : Vertical

Correct Marks : 4 Wrong Marks : 1

A battery of 3.0 V is connected to a resistor dissipating 0.5 W of power. If the terminal voltage of the battery is 2.5 V, the power dissipated within the internal resistance is :

Options :

40503640565. 0.125 W

40503640566. 0.50 W

40503640567. 0.072 W

40503640568. 0.10 W

Question Number : 12 Question Id : 40503611167 Question Type : MCQ Option Shuffling : Yes Display Question Number : Yes Is Question Mandatory : No Single Line Question Option : No Option Orientation : Vertical

Correct Marks : 4 Wrong Marks : 1

3.0 V की एक बैटरी एक प्रतिरोधक से जुड़ी हुई है। इस प्रतिरोधक में 0.5 W शक्ति का क्षय होता है। यदि बैटरी के सिरों (terminals) के बीच वोल्टता 2.5 V हो तो बैटरी के आंतरिक प्रतिरोध में क्षय होने वाली शक्ति का मान है :

Options :

40503640565. 0.125 W

40503640566. 0.50 W

40503640567. 0.072 W

40503640568. 0.10 W

Question Number : 13 Question Id : 40503611168 Question Type : MCQ Option Shuffling : Yes Display Question Number : Yes Is Question Mandatory : No Single Line Question Option : No Option Orientation : Vertical Correct Marks : 4 Wrong Marks : 1

A wire A, bent in the shape of an arc of a circle, carrying a current of 2 A and having radius 2 cm and another wire B, also bent in the shape of arc of a circle, carrying a current of 3 A and having radius of 4 cm, are placed as shown in the figure. The ratio of the magnetic fields due to the wires A and B at the common centre O is :

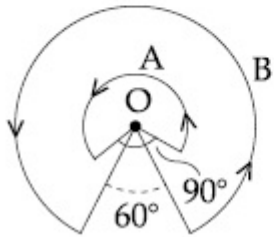

Options :

40503640569. 6 : 5

40503640570. 2 : 5

40503640571. 4 : 6

40503640572. 6 : 4

Question Number : 13 Question Id : 40503611168 Question Type : MCQ Option Shuffling : Yes Display Question Number : Yes Is Question Mandatory : No Single Line Question Option : No Option Orientation : Vertical Correct Marks : 4 Wrong Marks : 1

एक तार A का आकार एक वृत्त के चाप का है। इस वृत्त की त्रिज्या 2 cm है और इस तार में $2A$ की विद्युत धारा बह रही है। एक दूसरा तार B भी एक वृत्त के चाप के आकार का है और इस वृत्त की त्रिज्या 4 cm है तथा तार में $3A$ की धारा बह रही है (चित्र देखें)। इस स्थिति में इन वृत्तों के आम केन्द्र (common centre) O पर तार A और तार B से बनने वाले चुम्बकीय क्षेत्रों में मानों का अनुपात होगा :

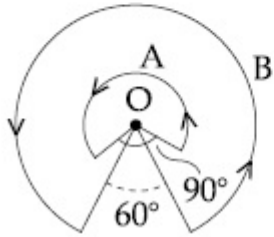

Options :

40503640569. 6 : 5

40503640570. 2 : 5

40503640571. 4 : 6

40503640572. 6 : 4

Question Number : 14 Question Id : 40503611169 Question Type : MCQ Option Shuffling : Yes Display Question Number : Yes Is Question Mandatory : No Single Line Question Option : No Option Orientation : Vertical Correct Marks : 4 Wrong Marks : 1

A small bar magnet placed with its axis at 30° with an external field of 0.06 T experiences a torque of 0.018 Nm. The minimum work required to rotate it from its stable to unstable equilibrium position is :

Options :

40503640573. 6.4×10^{-2} J

40503640574. 7.2×10^{-2} J

40503640575. 9.2×10^{-3} J

40503640576. 11.7×10^{-3} J

Question Number : 14 Question Id : 40503611169 Question Type : MCQ Option Shuffling : Yes Display Question Number : Yes Is Question Mandatory : No Single Line Question Option : No Option Orientation : Vertical

Correct Marks : 4 Wrong Marks : 1

एक दंड चुम्बक को यदि 0.06 T के एक बाहरी चुम्बकीय क्षेत्र में ऐसे रखा जाय कि इसका अक्ष चुम्बकीय क्षेत्र से 30° कोण बनाता हो, तो चुम्बक पर लगने वाला बल आघूर्ण 0.018 Nm है। ऐसे में यदि चुम्बक को इसके स्थायी साम्य से अस्थायी साम्य तक घुमाया जाय तो इस प्रक्रिया में किये जाने वाले न्यूनतम कार्य का मान होगा :

Options :

40503640573. 6.4×10^{-2} J

40503640574. $7.2 \times 10^{-2} \text{ J}$

40503640575. $9.2 \times 10^{-3} \text{ J}$

40503640576. $11.7 \times 10^{-3} \text{ J}$

Question Number : 15 Question Id : 40503611170 Question Type : MCQ Option Shuffling : Yes Display Question Number : Yes Is Question Mandatory : No Single Line Question Option : No Option Orientation : Vertical

Correct Marks : 4 Wrong Marks : 1

A small bar magnet is moved through a coil at constant speed from one end to the other. Which of the following series of observations will be seen on the galvanometer G attached across the coil ?

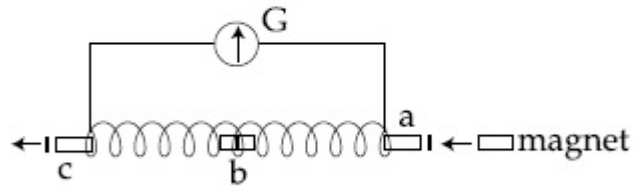

Three positions shown describe : (a) the magnet's entry (b) magnet is completely inside and (c) magnet's exit.

Options :

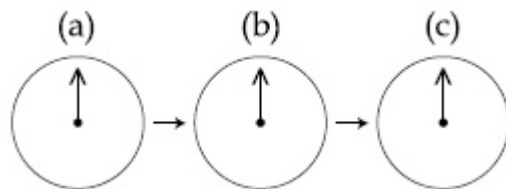

40503640577.

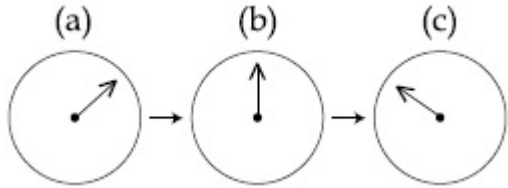

40503640578.

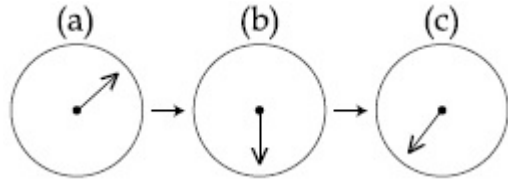

40503640579.

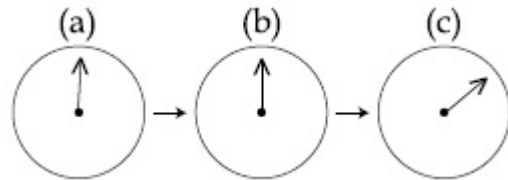

40503640580.

Question Number : 15 Question Id : 40503611170 Question Type : MCQ Option Shuffling : Yes Display Question Number : Yes Is Question Mandatory : No Single Line Question Option : No Option Orientation : Vertical Correct Marks : 4 Wrong Marks : 1

एक छोटे दंड चुम्बक को एक कुंडली के अन्दर एक सिरे से दूसरे सिरे तक समान गति से ले जाया जाता है। ऐसे में नीचे दिये गये श्रेणीबद्ध प्रेक्षण इस कुंडली पर लगे गैल्वेनोमापी G पर कैसे दिखेंगे ?

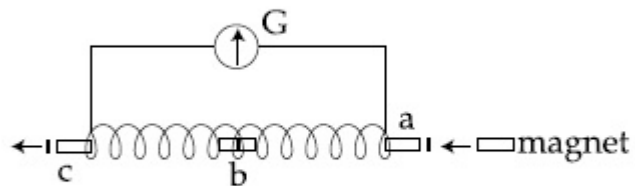

दिखायी गयी तीन स्थितियाँ हैं : (a) जब चुम्बक कुंडली में प्रवेश करता है, (b) जब चुम्बक पूरी तरह से कुंडली के अन्दर है, तथा (c) जब चुम्बक कुंडली के बाहर निकल रहा है।

Options :

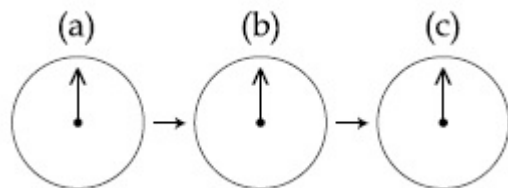

40503640577.

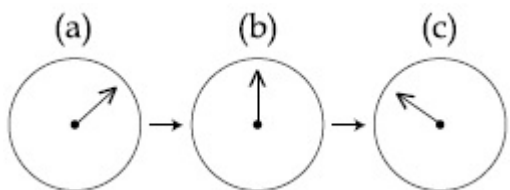

40503640578.

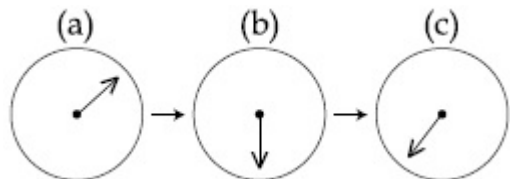

40503640579.

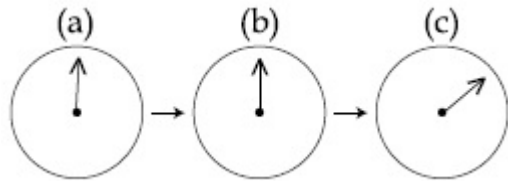

40503640580.

Question Number : 16 Question Id : 40503611171 Question Type : MCQ Option Shuffling : Yes Display Question Number : Yes Is Question Mandatory : No Single Line Question Option : No Option Orientation : Vertical

Correct Marks : 4 Wrong Marks : 1

Choose the correct option relating wavelengths of different parts of electromagnetic wave spectrum :

Options :

40503640581. $\lambda_{\text{radio waves}} > \lambda_{\text{micro waves}} > \lambda_{\text{visible}} > \lambda_{\text{x-rays}}$

40503640582. $\lambda_{\text{visible}} > \lambda_{\text{x-rays}} > \lambda_{\text{radio waves}} > \lambda_{\text{micro waves}}$

40503640583. $\lambda_{\text{x-rays}} < \lambda_{\text{micro waves}} < \lambda_{\text{radio waves}} < \lambda_{\text{visible}}$

40503640584. $\lambda_{\text{visible}} < \lambda_{\text{micro waves}} < \lambda_{\text{radio waves}} < \lambda_{\text{x-rays}}$

Question Number : 16 Question Id : 40503611171 Question Type : MCQ Option Shuffling : Yes Display Question Number : Yes Is Question Mandatory : No Single Line Question Option : No Option Orientation : Vertical

Correct Marks : 4 Wrong Marks : 1

निम्न में से विद्युत चुम्बकीय तरंगों के स्पेक्ट्रम के विभिन्न भागों के तरंगदैर्घ्यों के बीच सही सम्बंध को चुनिये :

Options :

40503640581. $\lambda_{\text{रेडियो तरंगें}} > \lambda_{\text{माइक्रो वेव}} > \lambda_{\text{दृश्य}} > \lambda_{\text{X-किरणें}}$

40503640582. $\lambda_{\text{दृश्य}} > \lambda_{\text{X-किरणें}} > \lambda_{\text{रेडियो तरंगें}} > \lambda_{\text{माइक्रो वेव}}$

40503640583. $\lambda_{\text{X-किरणें}} < \lambda_{\text{माइक्रो वेव}} < \lambda_{\text{रेडियो तरंगें}} < \lambda_{\text{दृश्य}}$

40503640584. $\lambda_{\text{दृश्य}} < \lambda_{\text{माइक्रो वेव}} < \lambda_{\text{रेडियो तरंगें}} < \lambda_{\text{X-किरणें}}$

Question Number : 17 Question Id : 40503611172 Question Type : MCQ Option Shuffling : Yes Display Question Number : Yes Is Question Mandatory : No Single Line Question Option : No Option Orientation : Vertical

Correct Marks : 4 Wrong Marks : 1

A beam of plane polarised light of large cross-sectional area and uniform intensity of 3.3 Wm^{-2} falls normally on a polariser (cross sectional area $3 \times 10^{-4} \text{ m}^2$) which rotates about its axis with an angular speed of 31.4 rad/s . The energy of light passing through the polariser per revolution, is close to :

Options :

40503640585. $1.0 \times 10^{-5} \text{ J}$

40503640586. 1.0×10^{-4} J

40503640587. 1.5×10^{-4} J

40503640588. 5.0×10^{-4} J

Question Number : 17 Question Id : 40503611172 Question Type : MCQ Option Shuffling : Yes Display Question Number : Yes Is Question Mandatory : No Single Line Question Option : No Option Orientation : Vertical

Correct Marks : 4 Wrong Marks : 1

बड़े अनुप्रस्थ काट क्षेत्रफल एवं एक समान तीव्रता 3.3 Wm^{-2} वाले एक समतल ध्रुवित प्रकाश का पुंज एक ध्रुवक (polariser) पर लम्बवत् पड़ता है। ध्रुवक का क्षेत्रफल $3 \times 10^{-4} \text{ m}^2$ है। ध्रुवक अपने अक्ष पर कोणीय गति 31.4 rad/s से घूम रहा है। ऐसे में प्रति परिभ्रमण इस ध्रुवक से होकर जाने वाली प्रकाश की ऊर्जा का मान लगभग क्या होगा? हो :

Options :

40503640585. 1.0×10^{-5} J

40503640586. 1.0×10^{-4} J

40503640587. 1.5×10^{-4} J

40503640588. 5.0×10^{-4} J

Question Number : 18 Question Id : 40503611173 Question Type : MCQ Option Shuffling : Yes Display Question Number : Yes Is Question Mandatory : No Single Line Question Option : No Option Orientation : Vertical

Correct Marks : 4 Wrong Marks : 1

Particle A of mass $m_A = \frac{m}{2}$ moving along the x -axis with velocity v_0 collides elastically with another particle B at rest having mass $m_B = \frac{m}{3}$. If both particles move along the x -axis after the collision, the change $\Delta\lambda$ in de-Broglie wavelength of particle A, in terms of its de-Broglie wavelength (λ_0) before collision is :

Options :

40503640589. $\Delta\lambda = \frac{3}{2} \lambda_0$

40503640590. $\Delta\lambda = 2\lambda_0$

40503640591. $\Delta\lambda = \frac{5}{2} \lambda_0$

40503640592. $\Delta\lambda = 4\lambda_0$

Question Number : 18 Question Id : 40503611173 Question Type : MCQ Option Shuffling : Yes Display Question Number : Yes Is Question Mandatory : No Single Line Question Option : No Option Orientation : Vertical Correct Marks : 4 Wrong Marks : 1

द्रव्यमान $m_A = \frac{m}{2}$ का कण A, x -अक्ष के साथ

v_0 गति से चलता हुआ द्रव्यमान $m_B = \frac{m}{3}$ के कण

B, जो विरामावस्था में है, से प्रत्यास्थतः टकराता है।
यदि संघट्ट के बाद दोनों कण x -अक्ष के साथ गतिशील हैं, तब कण A के डी-ब्रोग्ली तरंगदैर्घ्य में परिवर्तन $\Delta\lambda$ का मान इसके संघट्ट से पहले की डी-ब्रोग्ली तरंगदैर्घ्य (λ_0) से किस प्रकार संबंधित है?

Options :

40503640589. $\Delta\lambda = \frac{3}{2} \lambda_0$

40503640590. $\Delta\lambda = 2\lambda_0$

40503640591. $\Delta\lambda = \frac{5}{2} \lambda_0$

40503640592. $\Delta\lambda = 4\lambda_0$

Question Number : 19 Question Id : 40503611174 Question Type : MCQ Option Shuffling : Yes Display Question Number : Yes Is Question Mandatory : No Single Line Question Option : No Option Orientation : Vertical Correct Marks : 4 Wrong Marks : 1

Take the breakdown voltage of the zener diode used in the given circuit as 6V. For the input voltage shown in figure below, the time variation of the output voltage is :
(Graphs drawn are schematic and not to scale)

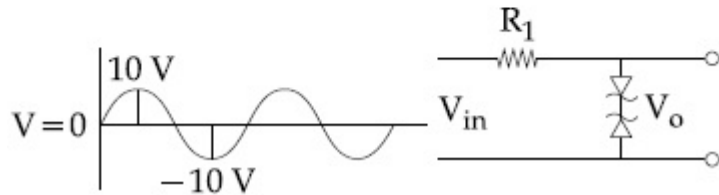

Options :

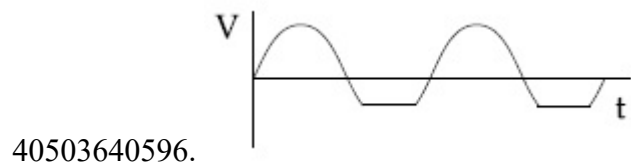
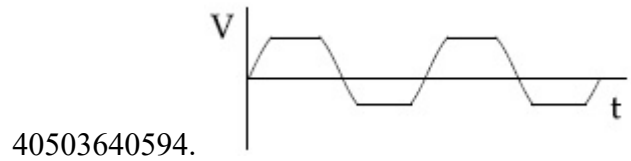
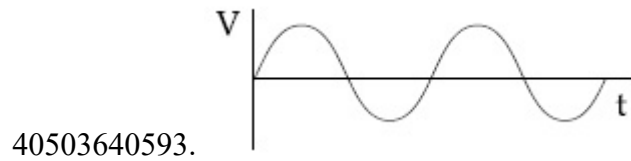

Question Number : 19 Question Id : 40503611174 Question Type : MCQ Option Shuffling : Yes Display Question Number : Yes Is Question Mandatory : No Single Line Question Option : No Option Orientation : Vertical

Correct Marks : 4 Wrong Marks : 1

दिये गये परिपथ में लगे ज़ीनर डायोडों की भंजन वोल्टता (breakdown voltage) 6V लें। तब चित्र में दिखायी गये निवेश (input) वोल्टता के लिये निर्गम (output) वोल्टता समय के साथ किस प्रकार बदलेगी?

(चित्र सांकेतिक है)

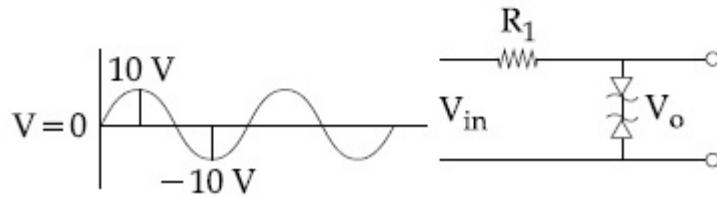

Options :

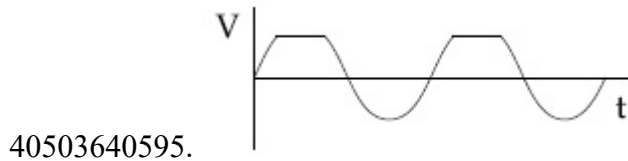
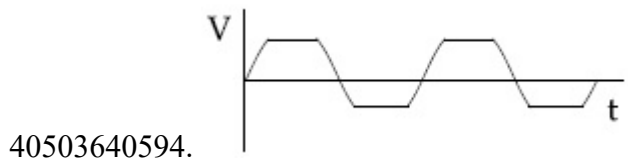
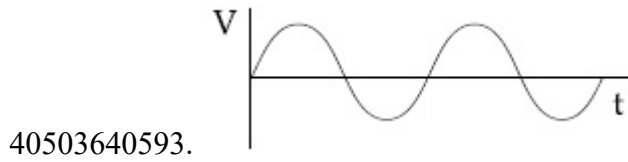

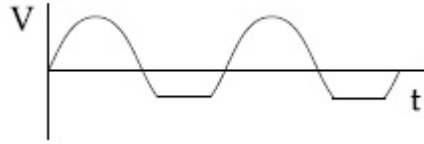

40503640596.

Question Number : 20 Question Id : 40503611175 Question Type : MCQ Option Shuffling : Yes Display Question Number : Yes Is Question Mandatory : No Single Line Question Option : No Option Orientation : Vertical

Correct Marks : 4 Wrong Marks : 1

Given figure shows few data points in a photo electric effect experiment for a certain metal. The minimum energy for ejection of electron from its surface is : (Plancks constant $h = 6.62 \times 10^{-34} \text{ J.s}$)

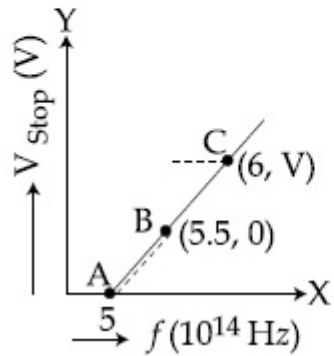

Options :

40503640597. 2.10 eV

40503640598. 1.93 eV

40503640599. 2.27 eV

40503640600. 2.59 eV

Question Number : 20 Question Id : 40503611175 Question Type : MCQ Option Shuffling : Yes Display Question Number : Yes Is Question Mandatory : No Single Line Question Option : No Option Orientation : Vertical

Correct Marks : 4 Wrong Marks : 1

दिये गये चित्र में एक धातु पर प्रकाश विद्युत प्रभाव के प्रयोग के कुछ आँकड़ों के बिन्दु दिखाये गये हैं। इस धातु की सतह से इलेक्ट्रॉन उत्सर्जित करने के लिये न्यूनतम आवश्यक ऊर्जा का मान है : (प्लांक स्थिरांक $h = 6.62 \times 10^{-34} \text{ J.s}$)

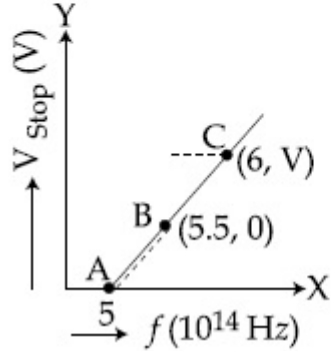

Options :

40503640597. 2.10 eV

40503640598. 1.93 eV

40503640599. 2.27 eV

40503640600. 2.59 eV

Sub-Section Number :

Sub-Section Id :

2

405036780

Question Shuffling Allowed :

Yes

Question Number : 21 Question Id : 40503611176 Question Type : SA Display Question Number : Yes

Correct Marks : 4 Wrong Marks : 0

ABC is a plane lamina of the shape of an equilateral triangle. D, E are mid points of AB, AC and G is the centroid of the lamina. Moment of inertia of the lamina about an axis passing through G and perpendicular to the plane ABC is I_0 . If part ADE is removed, the moment of inertia of the remaining part about the same axis is $\frac{NI_0}{16}$ where N is an integer. Value of N is

_____.

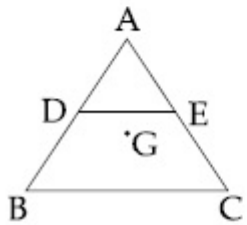

Response Type : Numeric

Evaluation Required For SA : Yes

Show Word Count : Yes

Answers Type : Range

Text Areas : PlainText

Possible Answers :

5 to 5.002

Question Number : 21 Question Id : 40503611176 Question Type : SA Display Question Number : Yes

Correct Marks : 4 Wrong Marks : 0

चित्र में ABC एक समबाहु त्रिभुज के आकार की परत (lamina) है। इसमें D और E क्रमशः AB और AC के मध्य-बिन्दु है तथा G इस परत का केन्द्रक है। केन्द्रक से होकर जाने वाले ABC तल के लम्बवत् अक्ष के सापेक्ष परत का जड़त्व आघूर्ण I_0 है। यदि परत से ADE भाग को हटा दिया जाय तो बचे हुए भाग का इसी अक्ष के सापेक्ष जड़त्व आघूर्ण $\frac{NI_0}{16}$ (N एक पूर्णांक है) हो जाता है। N का मान है _____।

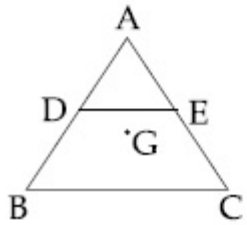

Response Type : Numeric

Evaluation Required For SA : Yes

Show Word Count : Yes

Answers Type : Range

Text Areas : PlainText

Possible Answers :

5 to 5.002

Question Number : 22 **Question Id :** 40503611177 **Question Type :** SA **Display Question Number :** Yes

Correct Marks : 4 **Wrong Marks :** 0

A circular disc of mass M and radius R is rotating about its axis with angular speed ω_1 . If another stationary disc having radius $\frac{R}{2}$ and same mass M is dropped co-axially on to the rotating disc. Gradually both discs attain constant angular speed ω_2 . The energy lost in the process is $p\%$ of the initial energy. Value of p is _____.

Response Type : Numeric

Evaluation Required For SA : Yes

Show Word Count : Yes

Answers Type : Range

Text Areas : PlainText

Possible Answers :

5 to 5.002

Question Number : 22 **Question Id :** 40503611177 **Question Type :** SA **Display Question Number :** Yes

Correct Marks : 4 **Wrong Marks :** 0

द्रव्यमान M तथा त्रिज्या R की एक डिस्क अपने अक्ष पर कोणीय गति ω_1 से घूम रही है। इस डिस्क पर एक स्थिर डिस्क जिसका द्रव्यमान M पर त्रिज्या $\frac{R}{2}$ है समाक्षतः (coaxially) रख दी जाती है। जिससे धीरे-धीरे दोनों डिस्क अन्त में एक साथ कोणीय गति ω_2 से घूमने लगती है। इस प्रक्रिया में मूल ऊर्जा की $p\%$ ऊर्जा की क्षति हो जाती है। p का मान है _____।

Response Type : Numeric

Evaluation Required For SA : Yes

Show Word Count : Yes

Answers Type : Range

Text Areas : PlainText

Possible Answers :

5 to 5.002

Question Number : 23 Question Id : 40503611178 Question Type : SA Display Question Number : Yes

Correct Marks : 4 Wrong Marks : 0

A closed vessel contains 0.1 mole of a monatomic ideal gas at 200 K. If 0.05 mole of the same gas at 400 K is added to it, the final equilibrium temperature (in K) of the gas in the vessel will be close to

_____.

Response Type : Numeric

Evaluation Required For SA : Yes

Show Word Count : Yes

Answers Type : Range

Text Areas : PlainText

Possible Answers :

5 to 5.002

Question Number : 23 Question Id : 40503611178 Question Type : SA Display Question Number : Yes

Correct Marks : 4 Wrong Marks : 0

एक बन्द बर्तन में 200 K तापमान पर 0.1 मोल एक परमाणुक आदर्श गैस भरी हुई है। यदि 400 K तापमान वाली इसी गैस के 0.05 मोल और भर दिये जायें तो साम्यावस्था में इस बर्तन में भरी गैस का तापमान (K में) होगा _____।

Response Type : Numeric

Evaluation Required For SA : Yes

Show Word Count : Yes

Answers Type : Range

Text Areas : PlainText

Possible Answers :

5 to 5.002

Question Number : 24 **Question Id :** 40503611179 **Question Type :** SA Display **Question Number :** Yes

Correct Marks : 4 **Wrong Marks :** 0

In a compound microscope, the magnified virtual image is formed at a distance of 25 cm from the eye-piece. The focal length of its objective lens is 1 cm. If the magnification is 100 and the tube length of the microscope is 20 cm, then the focal length of the eye-piece lens (in cm) is

_____.

Response Type : Numeric

Evaluation Required For SA : Yes

Show Word Count : Yes

Answers Type : Range

Text Areas : PlainText

Possible Answers :

5 to 5.002

Question Number : 24 **Question Id :** 40503611179 **Question Type :** SA Display **Question Number :** Yes

Correct Marks : 4 **Wrong Marks :** 0

एक संयुक्त सूक्ष्मदर्शी (compound microscope) में आवर्धित आभासी प्रतिबिम्ब (magnified virtual image) नेत्रिका से 25 cm दूरी पर बनता है। इसके अभिदृश्यक लेन्स की फोकस दूरी 1 cm है। यदि आवर्धन 100 हो और सूक्ष्मदर्शी की नली की लम्बाई 20 cm हो तो इसके नेत्रिका लेन्स की फोकस दूरी (cm में) होगी _____।

Response Type : Numeric

Evaluation Required For SA : Yes

Show Word Count : Yes

Answers Type : Range

Text Areas : PlainText

Possible Answers :

5 to 5.002

Question Number : 25 **Question Id :** 40503611180 **Question Type :** SA Display **Question Number :** Yes

Correct Marks : 4 **Wrong Marks :** 0

In the line spectra of hydrogen atom, difference between the largest and the shortest wavelengths of the Lyman series is 304 \AA . The corresponding difference for the Paschan series in \AA is : _____.

Response Type : Numeric

Evaluation Required For SA : Yes

Show Word Count : Yes

Answers Type : Range

Text Areas : PlainText

Possible Answers :

5 to 5.002

Question Number : 25 Question Id : 40503611180 Question Type : SA Display Question Number : Yes

Correct Marks : 4 Wrong Marks : 0

हाइड्रोजन परमाणु के स्पेक्ट्रम की लाइमन श्रेणी में सबसे लम्बी और सबसे छोटी तरंगदैर्घ्यों की लम्बाई में 304 \AA का अन्तर है। तब पाशन श्रेणी की सबसे लम्बी और सबसे छोटी तरंगदैर्घ्यों की लम्बाई में \AA में अन्तर होगा _____।

Response Type : Numeric

Evaluation Required For SA : Yes

Show Word Count : Yes

Answers Type : Range

Text Areas : PlainText

Possible Answers :

5 to 5.002

Chemistry

Section Id :	405036407
Section Number :	2
Section type :	Online
Mandatory or Optional :	Mandatory
Number of Questions :	25
Number of Questions to be attempted :	25
Section Marks :	100
Display Number Panel :	Yes
Group All Questions :	Yes
Mark As Answered Required? :	Yes
Sub-Section Number :	1
Sub-Section Id :	405036781
Question Shuffling Allowed :	Yes

Question Number : 26 Question Id : 40503611181 Question Type : MCQ Option Shuffling : Yes Display Question Number : Yes Is Question Mandatory : No Single Line Question Option : No Option Orientation : Vertical

Correct Marks : 4 Wrong Marks : 1

Match the following :

- | | |
|---------------|----------------|
| (i) Foam | (a) smoke |
| (ii) Gel | (b) cell fluid |
| (iii) Aerosol | (c) jellies |
| (iv) Emulsion | (d) rubber |
| | (e) froth |
| | (f) milk |

Options :

40503640606. (i)-(e), (ii)-(c), (iii)-(a), (iv)-(f)

40503640607. (i)-(b), (ii)-(c), (iii)-(e), (iv)-(d)

40503640608. (i)-(d), (ii)-(b), (iii)-(e), (iv)-(f)

40503640609. (i)-(d), (ii)-(b), (iii)-(a), (iv)-(e)

Question Number : 26 Question Id : 40503611181 Question Type : MCQ Option Shuffling : Yes Display Question Number : Yes Is Question Mandatory : No Single Line Question Option : No Option Orientation : Vertical

Correct Marks : 4 Wrong Marks : 1

निम्न को सुमेलित कीजिए :

- | | |
|--------------|------------------|
| (i) फोम | (a) स्मोक (धुआँ) |
| (ii) जेल | (b) सेल तरल |
| (iii) ऐरोसॉल | (c) जेली |
| (iv) इमल्शन | (d) रबर |
| | (e) फ्रॉथ |
| | (f) दूध |

Options :

40503640606. (i)-(e), (ii)-(c), (iii)-(a), (iv)-(f)

40503640607. (i)-(b), (ii)-(c), (iii)-(e), (iv)-(d)

40503640608. (i)-(d), (ii)-(b), (iii)-(e), (iv)-(f)

40503640609. (i)-(d), (ii)-(b), (iii)-(a), (iv)-(e)

Question Number : 27 Question Id : 40503611182 Question Type : MCQ Option Shuffling : Yes Display Question Number : Yes Is

Question Mandatory : No Single Line Question Option : No Option Orientation : Vertical

Correct Marks : 4 Wrong Marks : 1

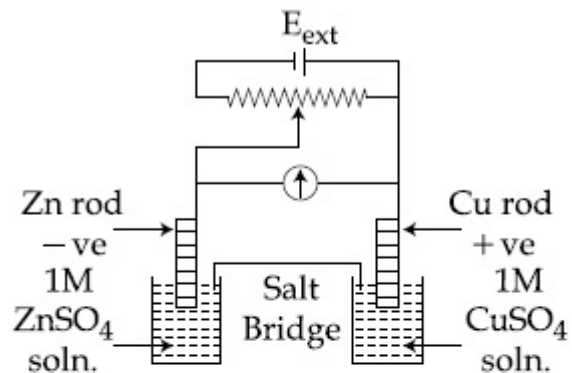

$$E_{\text{Cu}^{2+}|\text{Cu}}^{\circ} = +0.34 \text{ V}$$

$$E_{\text{Zn}^{2+}|\text{Zn}}^{\circ} = -0.76 \text{ V}$$

Identify the incorrect statement from the options below for the above cell :

Options :

40503640610. If $E_{\text{ext}} < 1.1 \text{ V}$, Zn dissolves at anode and Cu deposits at cathode

40503640611. If $E_{\text{ext}} = 1.1 \text{ V}$, no flow of e^{-} or current occurs

40503640612. If $E_{\text{ext}} > 1.1 \text{ V}$, e^{-} flows from Cu to Zn

40503640613. If $E_{\text{ext}} > 1.1 \text{ V}$, Zn dissolves at Zn electrode and Cu deposits at Cu electrode

Question Number : 27 Question Id : 40503611182 Question Type : MCQ Option Shuffling : Yes Display Question Number : Yes Is Question Mandatory : No Single Line Question Option : No Option Orientation : Vertical Correct Marks : 4 Wrong Marks : 1

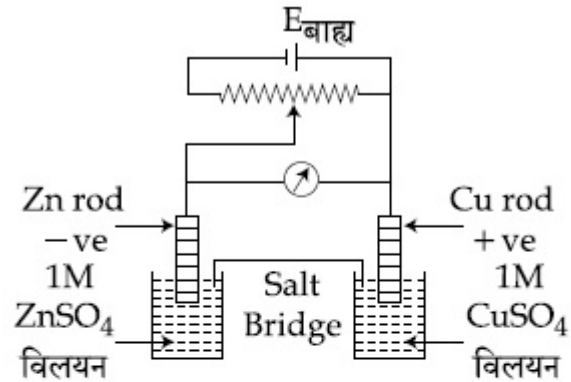

$$E_{\text{Cu}^{2+}|\text{Cu}}^{\circ} = +0.34 \text{ V}$$

$$E_{\text{Zn}^{2+}|\text{Zn}}^{\circ} = -0.76 \text{ V}$$

उपरोक्त सेल के लिए नीचे दिये गये विकल्पों में से गलत कथन को पहचानिये :

Options :

40503640610. यदि $E_{\text{बाह्य}} < 1.1 \text{ V}$, जिंक एनोड पर घुलता है तथा Cu कैथोड पर जमा होता है।

40503640611. यदि $E_{\text{बाह्य}} = 1.1 \text{ V}$, e^{-} अथवा धारा का प्रवाह नहीं होगा।

40503640612. यदि $E_{\text{बाह्य}} > 1.1 \text{ V}$, इलेक्ट्रॉन का प्रवाह कॉपर से जिंक को होगा।

यदि $E_{\text{बाह्य}} > 1.1 \text{ V}$, Zn, जिंक इलेक्ट्रोड पर घुलता है तथा Cu, कापर इलेक्ट्रोड पर जमा होता है।

40503640613.

Question Number : 28 Question Id : 40503611183 Question Type : MCQ Option Shuffling : Yes Display Question Number : Yes Is Question Mandatory : No Single Line Question Option : No Option Orientation : Vertical

Correct Marks : 4 Wrong Marks : 1

For the equilibrium $A \rightleftharpoons B$, the variation of the rate of the forward (a) and reverse (b) reaction with time is given by :

Options :

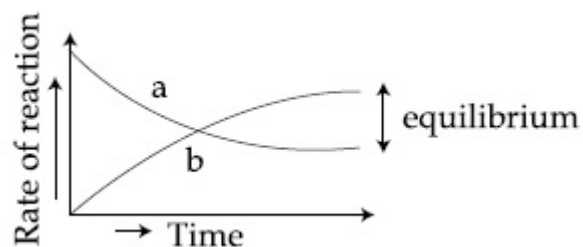
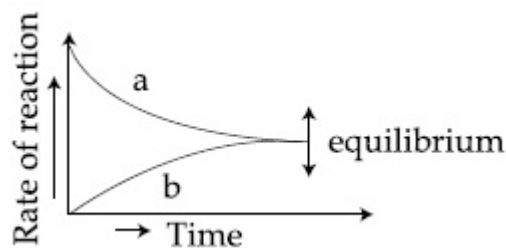

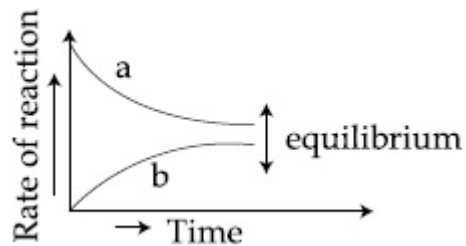

40503640616.

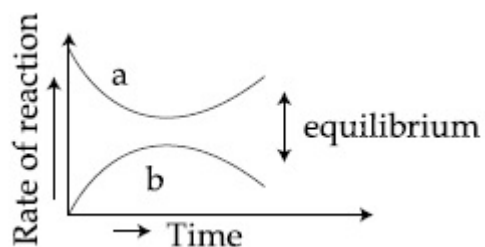

40503640617.

Question Number : 28 Question Id : 40503611183 Question Type : MCQ Option Shuffling : Yes Display Question Number : Yes Is Question Mandatory : No Single Line Question Option : No Option Orientation : Vertical Correct Marks : 4 Wrong Marks : 1

साम्य, $A \rightleftharpoons B$, के लिए, समय के साथ अग्र (a) तथा उल्लम (b) अभिक्रिया की दर का परिवर्तन निम्न के द्वारा दिया जायेगा :

Options :

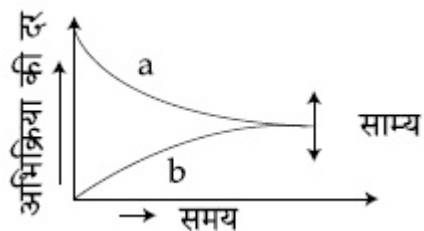

40503640614.

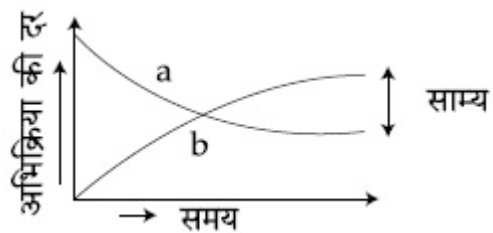

40503640615.

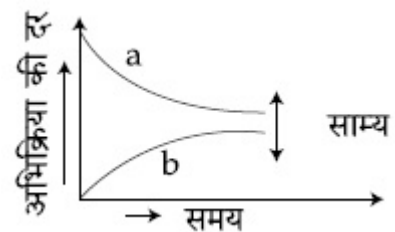

40503640616.

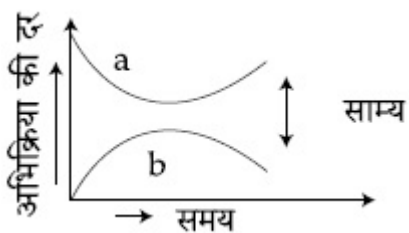

40503640617.

Question Number : 29 Question Id : 40503611184 Question Type : MCQ Option Shuffling : Yes Display Question Number : Yes Is Question Mandatory : No Single Line Question Option : No Option Orientation : Vertical Correct Marks : 4 Wrong Marks : 1

For one mole of an ideal gas, which of these statements must be true ?

- (a) U and H each depends only on temperature
- (b) Compressibility factor z is not equal to 1
- (c) $C_{P,m} - C_{V,m} = R$
- (d) $dU = C_V dT$ for any process

Options :

40503640618. (c) and (d)

40503640619. (a) and (c)

40503640620. (b), (c) and (d)

40503640621. (a), (c) and (d)

Question Number : 29 Question Id : 40503611184 Question Type : MCQ Option Shuffling : Yes Display Question Number : Yes Is Question Mandatory : No Single Line Question Option : No Option Orientation : Vertical

Correct Marks : 4 Wrong Marks : 1

एक आदर्श गैस के एक मोल के लिए, इन कथनों में से कौन सत्य होना चाहिए ?

- (a) U तथा H प्रत्येक मात्र ताप पर निर्भर करते हैं।
- (b) संपीड्यता गुणांक z , 1 के बराबर नहीं है।
- (c) $C_{P,m} - C_{V,m} = R$
- (d) $dU = C_V dT$ किसी प्रक्रम के लिए

Options :

40503640618. (c) तथा (d)

40503640619. (a) तथा (c)

40503640620. (b), (c) तथा (d)

40503640621. (a), (c) तथा (d)

Question Number : 30 Question Id : 40503611185 Question Type : MCQ Option Shuffling : Yes Display Question Number : Yes Is Question Mandatory : No Single Line Question Option : No Option Orientation : Vertical Correct Marks : 4 Wrong Marks : 1

The intermolecular potential energy for the molecules A, B, C and D given below suggests that :

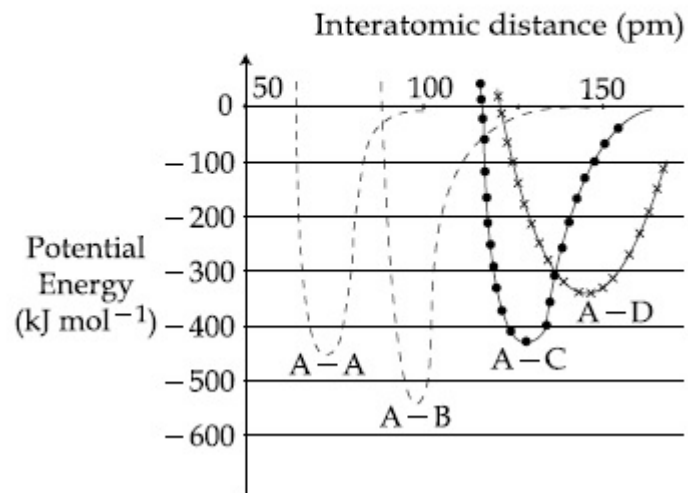

Options :

40503640622. A-A has the largest bond enthalpy.

40503640623. A-B has the stiffest bond.

40503640624. A-D has the shortest bond length.

40503640625. D is more electronegative than other atoms.

Question Number : 30 Question Id : 40503611185 Question Type : MCQ Option Shuffling : Yes Display Question Number : Yes Is Question Mandatory : No Single Line Question Option : No Option Orientation : Vertical Correct Marks : 4 Wrong Marks : 1

अणुओं के लिए अंतराअणुक स्थितिज ऊर्जा जो A, B, C तथा D द्वारा नीचे दिखाये गये हैं, बताते हैं कि :

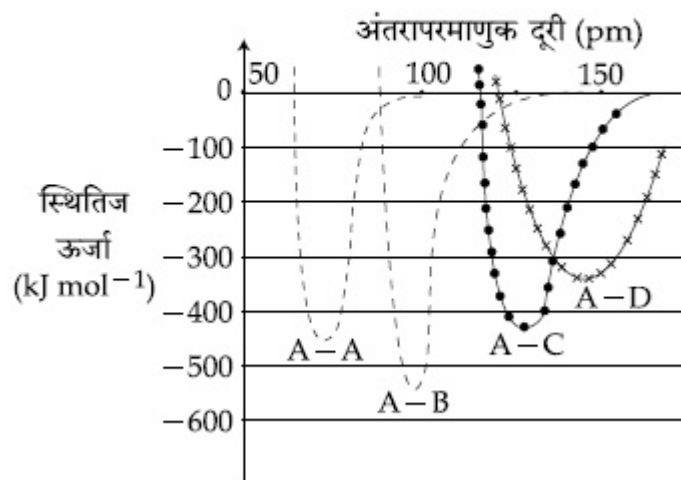

Options :

40503640622. A-A की आबन्ध एन्थैल्पी अधिकतम है।

40503640623. A-B का आबन्ध सर्वाधिक सख्त है।

40503640624. A-D की आबन्ध लम्बाई लघुत्तम है।

40503640625. अन्य परमाणुओं की तुलना में D ज्यादा ऋण विद्युती है।

Question Number : 31 Question Id : 40503611186 Question Type : MCQ Option Shuffling : Yes Display Question Number : Yes Is Question Mandatory : No Single Line Question Option : No Option Orientation : Vertical Correct Marks : 4 Wrong Marks : 1

The region in the electromagnetic spectrum where the Balmer series lines appear is :

Options :

40503640626. Ultraviolet

40503640627. Visible

40503640628. Infrared

40503640629. Microwave

Question Number : 31 Question Id : 40503611186 Question Type : MCQ Option Shuffling : Yes Display Question Number : Yes Is Question Mandatory : No Single Line Question Option : No Option Orientation : Vertical Correct Marks : 4 Wrong Marks : 1

विद्युत चुम्बकीय स्पेक्ट्रम में वह क्षेत्र, जहाँ बामर श्रेणी की लाइनें मिलती हैं, होगा :

Options :

40503640626. पराबैंगनी

40503640627. दृश्य

40503640628. अवरक्त

40503640629. माइक्रोवेव

Question Number : 32 Question Id : 40503611187 Question Type : MCQ Option Shuffling : Yes Display Question Number : Yes Is Question Mandatory : No Single Line Question Option : No Option Orientation : Vertical Correct Marks : 4 Wrong Marks : 1

The ionic radii of O^{2-} , F^- , Na^+ and Mg^{2+} are in the order :

Options :

40503640630. $O^{2-} > F^- > Na^+ > Mg^{2+}$

40503640631. $Mg^{2+} > Na^+ > F^- > O^{2-}$

40503640632. $O^{2-} > F^- > Mg^{2+} > Na^+$

40503640633. $F^- > O^{2-} > Na^+ > Mg^{2+}$

Question Number : 32 Question Id : 40503611187 Question Type : MCQ Option Shuffling : Yes Display Question Number : Yes Is Question Mandatory : No Single Line Question Option : No Option Orientation : Vertical Correct Marks : 4 Wrong Marks : 1

O^{2-} , F^- , Na^+ तथा Mg^{2+} की आयनिक त्रिज्याएँ इस क्रम में हैं :

Options :

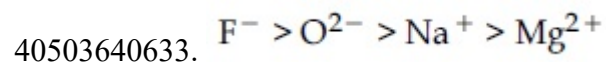
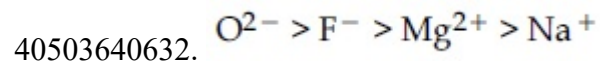
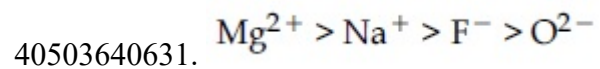
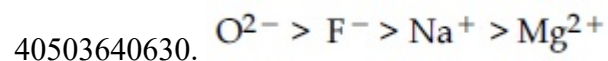

Question Number : 33 Question Id : 40503611188 Question Type : MCQ Option Shuffling : Yes Display Question Number : Yes Is Question Mandatory : No Single Line Question Option : No Option Orientation : Vertical

Correct Marks : 4 Wrong Marks : 1

Among statements (a) - (d), the correct ones are :

- (a) Lime stone is decomposed to CaO during the extraction of iron from its oxides.
- (b) In the extraction of silver, silver is extracted as an anionic complex.
- (c) Nickel is purified by Mond's process.
- (d) Zr and Ti are purified by Van Arkel method.

Options :

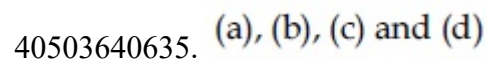
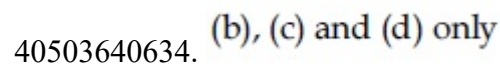

40503640636. (c) and (d) only

40503640637. (a), (c) and (d) only

Question Number : 33 Question Id : 40503611188 Question Type : MCQ Option Shuffling : Yes Display Question Number : Yes Is Question Mandatory : No Single Line Question Option : No Option Orientation : Vertical Correct Marks : 4 Wrong Marks : 1

(a) - (d) कथनों में, सही कथन हैं :

- (a) आयरन को इसकी ऑक्साइड से निष्कर्षित करने में लाइम स्टोन (चूनापत्थर) CaO में विघटित हो जाता है।
- (b) सिल्वर के निष्कर्षण में, सिल्वर एक ऋणायनी संकुल के रूप में निष्कर्षित होता है।
- (c) निकल को मान्ड प्रक्रम द्वारा शुद्ध करते हैं।
- (d) Zr तथा Ti को वान आर्केल विधि से शुद्ध करते हैं।

Options :

40503640634. केवल (b), (c) तथा (d)

40503640635. (a), (b), (c) तथा (d)

40503640636. केवल (c) तथा (d)

40503640637. केवल (a), (c) तथा (d)

Question Number : 34 Question Id : 40503611189 Question Type : MCQ Option Shuffling : Yes Display Question Number : Yes Is Question Mandatory : No Single Line Question Option : No Option Orientation : Vertical

Correct Marks : 4 Wrong Marks : 1

On combustion of Li, Na and K in excess of air, the major oxides formed, respectively, are :

Options :

40503640638. Li_2O , Na_2O and K_2O_2

40503640639. Li_2O , Na_2O_2 and KO_2

40503640640. Li_2O , Na_2O_2 and K_2O

40503640641. Li_2O_2 , Na_2O_2 and K_2O_2

Question Number : 34 Question Id : 40503611189 Question Type : MCQ Option Shuffling : Yes Display Question Number : Yes Is Question Mandatory : No Single Line Question Option : No Option Orientation : Vertical

Correct Marks : 4 Wrong Marks : 1

वायु के आधिक्य में Li, Na तथा K के दहन पर बननेवाली प्रमुख आक्साइडें क्रमशः हैं :

Options :

40503640638. Li_2O , Na_2O तथा K_2O_2

40503640639. Li_2O , Na_2O_2 तथा KO_2

40503640640. Li_2O , Na_2O_2 तथा K_2O

40503640641. Li_2O_2 , Na_2O_2 तथा K_2O_2

Question Number : 35 Question Id : 40503611190 Question Type : MCQ Option Shuffling : Yes Display Question Number : Yes Is Question Mandatory : No Single Line Question Option : No Option Orientation : Vertical

Correct Marks : 4 Wrong Marks : 1

On heating, lead(II) nitrate gives a brown gas (A). The gas (A) on cooling changes to a colourless solid/liquid (B). (B) on heating with NO changes to a blue solid (C). The oxidation number of nitrogen in solid (C) is :

Options :

40503640642. +2

40503640643. +3

40503640644. +4

40503640645. +5

Question Number : 35 Question Id : 40503611190 Question Type : MCQ Option Shuffling : Yes Display Question Number : Yes Is Question Mandatory : No Single Line Question Option : No Option Orientation : Vertical

Correct Marks : 4 Wrong Marks : 1

लेड(II) नाइट्रेट गरम करने पर एक भूरे रंग की गैस (A) देता है। गैस (A) ठंडा करने पर एक रंगहीन ठोस /द्रव (B) में परिवर्तित हो जाता है। (B), NO के साथ गरम करने पर एक नीले रंग के ठोस (C) में बदल जाता है। ठोस (C) में नाइट्रोजन की ऑक्सीकरण संख्या है :

Options :

40503640642. +2

40503640643. +3

40503640644. +4

40503640645. +5

Question Number : 36 Question Id : 4050361191 Question Type : MCQ Option Shuffling : Yes Display Question Number : Yes Is Question Mandatory : No Single Line Question Option : No Option Orientation : Vertical Correct Marks : 4 Wrong Marks : 1

The elements with atomic numbers 101 and 104 belong to, respectively, :

Options :

40503640646. Group 11 and Group 4

40503640647. Actinoids and Group 6

40503640648. Group 6 and Actinoids

40503640649. Actinoids and Group 4

Question Number : 36 Question Id : 40503611191 Question Type : MCQ Option Shuffling : Yes Display Question Number : Yes Is Question Mandatory : No Single Line Question Option : No Option Orientation : Vertical

Correct Marks : 4 Wrong Marks : 1

तत्व, जिनकी परमाणु संख्या 101 तथा 104 हैं, क्रमशः
इनसे सम्बन्धित है :

Options :

40503640646. ग्रुप 11 तथा ग्रुप 4

40503640647. ऐक्टिन्वायड्स तथा ग्रुप 6

40503640648. ग्रुप 6 तथा ऐक्टिन्वायड्स

40503640649. ऐक्टिन्वायड्स तथा ग्रुप 4

Question Number : 37 Question Id : 40503611192 Question Type : MCQ Option Shuffling : Yes Display Question Number : Yes Is Question Mandatory : No Single Line Question Option : No Option Orientation : Vertical

Correct Marks : 4 Wrong Marks : 1

The number of isomers possible for
[Pt(en)(NO₂)₂] is :

Options :

40503640650. 1

40503640651. 2

40503640652. 3

40503640653. 4

Question Number : 37 Question Id : 40503611192 Question Type : MCQ Option Shuffling : Yes Display Question Number : Yes Is Question Mandatory : No Single Line Question Option : No Option Orientation : Vertical

Correct Marks : 4 Wrong Marks : 1

[Pt(en)(NO₂)₂] के लिए संभव समावयवियों की संख्या है :

Options :

40503640650. 1

40503640651. 2

40503640652. 3

40503640653. 4

Question Number : 38 Question Id : 40503611193 Question Type : MCQ Option Shuffling : Yes Display Question Number : Yes Is Question Mandatory : No Single Line Question Option : No Option Orientation : Vertical

Correct Marks : 4 Wrong Marks : 1

The pair in which both the species have the same magnetic moment (spin only) is :

Options :

40503640654. [Cr(H₂O)₆]²⁺ and [CoCl₄]²⁻

40503640655. [Cr(H₂O)₆]²⁺ and [Fe(H₂O)₆]²⁺

40503640656. $[\text{Mn}(\text{H}_2\text{O})_6]^{2+}$ and $[\text{Cr}(\text{H}_2\text{O})]^{2+}$

40503640657. $[\text{Co}(\text{OH})_4]^{2-}$ and $[\text{Fe}(\text{NH}_3)_6]^{2+}$

Question Number : 38 Question Id : 40503611193 Question Type : MCQ Option Shuffling : Yes Display Question Number : Yes Is Question Mandatory : No Single Line Question Option : No Option Orientation : Vertical

Correct Marks : 4 Wrong Marks : 1

वह युग्म, जिसमें दोनों स्पीशीज़ का वही चुम्बकीय आघूर्ण (स्पिन मात्र) है, होगा :

Options :

40503640654. $[\text{Cr}(\text{H}_2\text{O})_6]^{2+}$ तथा $[\text{CoCl}_4]^{2-}$

40503640655. $[\text{Cr}(\text{H}_2\text{O})_6]^{2+}$ तथा $[\text{Fe}(\text{H}_2\text{O})_6]^{2+}$

40503640656. $[\text{Mn}(\text{H}_2\text{O})_6]^{2+}$ तथा $[\text{Cr}(\text{H}_2\text{O})]^{2+}$

40503640657. $[\text{Co}(\text{OH})_4]^{2-}$ तथा $[\text{Fe}(\text{NH}_3)_6]^{2+}$

Question Number : 39 Question Id : 40503611194 Question Type : MCQ Option Shuffling : Yes Display Question Number : Yes Is Question Mandatory : No Single Line Question Option : No Option Orientation : Vertical

Correct Marks : 4 Wrong Marks : 1

An organic compound (A) (molecular formula $C_6H_{12}O_2$) was hydrolysed with dil. H_2SO_4 to give a carboxylic acid (B) and an alcohol (C). 'C' gives white turbidity immediately when treated with anhydrous $ZnCl_2$ and conc. HCl . The organic compound (A) is :

Options :

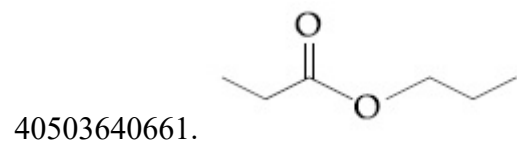
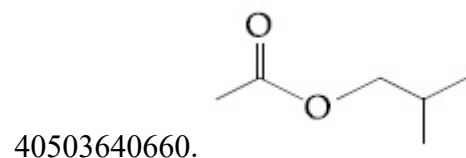
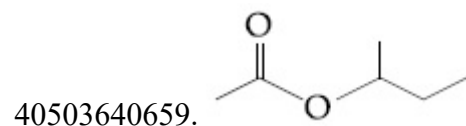
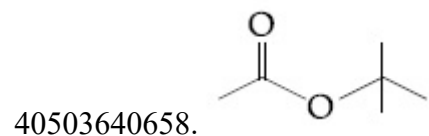

Question Number : 39 Question Id : 40503611194 Question Type : MCQ Option Shuffling : Yes Display Question Number : Yes Is Question Mandatory : No Single Line Question Option : No Option Orientation : Vertical Correct Marks : 4 Wrong Marks : 1

एक कार्बनिक यौगिक (A) (अणुसूत्र $C_6H_{12}O_2$) को तनु H_2SO_4 के साथ जलअपघटित किया गया जिससे कार्बोक्सिलिक एसिड (B) तथा ऐल्कोहॉल (C) मिलता है। जब निर्जल $ZnCl_2$ तथा सान्द्र HCl के साथ अभिकृत किया गया तो 'C' एक सफेद अविलता तुरंत देता है। कार्बनिक यौगिक (A) है :

Options :

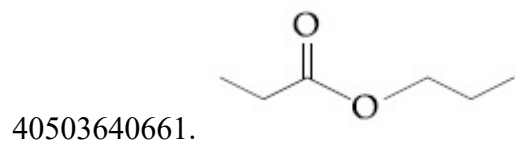
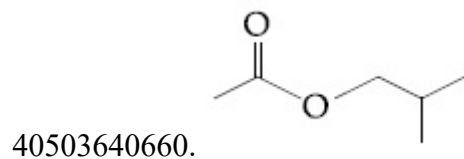
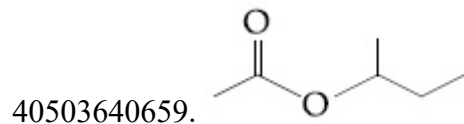
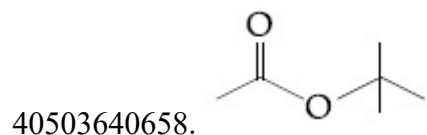

Question Number : 40 Question Id : 40503611195 Question Type : MCQ Option Shuffling : Yes Display Question Number : Yes Is Question Mandatory : No Single Line Question Option : No Option Orientation : Vertical Correct Marks : 4 Wrong Marks : 1

The IUPAC name of the following compound is :

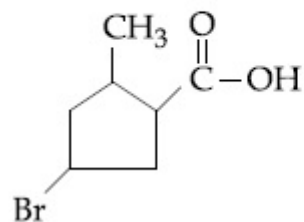

Options :

40503640662. 3-Bromo-5-methylcyclopentanoic acid

40503640663. 4-Bromo-2-methylcyclopentane carboxylic acid

40503640664. 3-Bromo-5-methylcyclopentane carboxylic acid

40503640665. 5-Bromo-3-methylcyclopentanoic acid

Question Number : 40 Question Id : 40503611195 Question Type : MCQ Option Shuffling : Yes Display Question Number : Yes Is Question Mandatory : No Single Line Question Option : No Option Orientation : Vertical

Correct Marks : 4 Wrong Marks : 1

निम्न यौगिक का आईयूपीएसी नाम है :

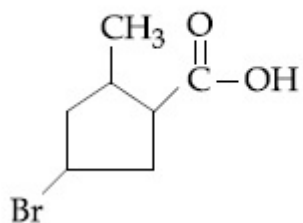

Options :

40503640662. 3-ब्रोमो-5-मेथिलसायक्लोपेन्टानोइक एसिड

40503640663. 4-ब्रोमो-2-मेथिलसायक्लोपेन्टेन कार्बाक्सिलिक एसिड

40503640664. 3-ब्रोमो-5-मेथिलसायक्लोपेन्टेन कार्बाक्सिलिक एसिड

40503640665. 5-ब्रोमो-3-मेथिलसायक्लोपेन्टेनोइक एसिड

Question Number : 41 Question Id : 40503611196 Question Type : MCQ Option Shuffling : Yes Display Question Number : Yes Is

Question Mandatory : No Single Line Question Option : No Option Orientation : Vertical

Correct Marks : 4 Wrong Marks : 1

The decreasing order of reactivity of the following organic molecules towards AgNO_3 solution is :



(A)

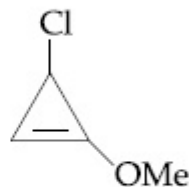

(B)

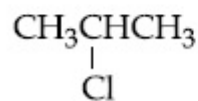

(C)



(D)

Options :

40503640666. (A) > (B) > (C) > (D)

40503640667. (B) > (A) > (C) > (D)

40503640668. (A) > (B) > (D) > (C)

40503640669. (C) > (D) > (A) > (B)

Question Number : 41 Question Id : 40503611196 Question Type : MCQ Option Shuffling : Yes Display Question Number : Yes Is Question Mandatory : No Single Line Question Option : No Option Orientation : Vertical Correct Marks : 4 Wrong Marks : 1

AgNO₃ घोल के प्रति निम्न कार्बनिक अणुओं की अभिक्रियाशीलता का घटता क्रम है :



(A)

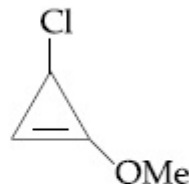

(B)

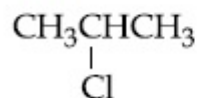

(C)



(D)

Options :

40503640666. (A) > (B) > (C) > (D)

40503640667. (B) > (A) > (C) > (D)

40503640668. (A) > (B) > (D) > (C)

40503640669. (C) > (D) > (A) > (B)

Question Number : 42 Question Id : 40503611197 Question Type : MCQ Option Shuffling : Yes Display Question Number : Yes Is Question Mandatory : No Single Line Question Option : No Option Orientation : Vertical

Correct Marks : 4 Wrong Marks : 1

What are the functional groups present in the structure of maltose ?

Options :

40503640670. One acetal and one ketal
40503640671. One acetal and one hemiacetal
40503640672. One ketal and one hemiketal
40503640673. Two acetals

Question Number : 42 Question Id : 40503611197 Question Type : MCQ Option Shuffling : Yes Display Question Number : Yes Is Question Mandatory : No Single Line Question Option : No Option Orientation : Vertical Correct Marks : 4 Wrong Marks : 1

माल्टोज की संरचना में उपस्थित कौन अभिलक्षणीय समूह हैं ?

Options :

40503640670. एक ऐसीटल तथा एक केटल
40503640671. एक ऐसीटल तथा एक हेमीऐसिटल
40503640672. एक केटल तथा एक हेमीकेटल
40503640673. दो ऐसिटल

Question Number : 43 Question Id : 40503611198 Question Type : MCQ Option Shuffling : Yes Display Question Number : Yes Is Question Mandatory : No Single Line Question Option : No Option Orientation : Vertical Correct Marks : 4 Wrong Marks : 1

[P] on treatment with $\text{Br}_2/\text{FeBr}_3$ in CCl_4 produced a single isomer $\text{C}_8\text{H}_7\text{O}_2\text{Br}$ while heating [P] with sodalime gave toluene. The compound [P] is :

Options :

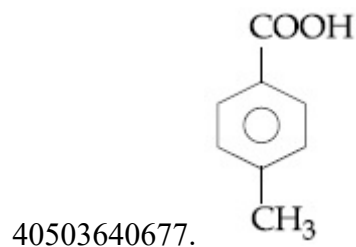
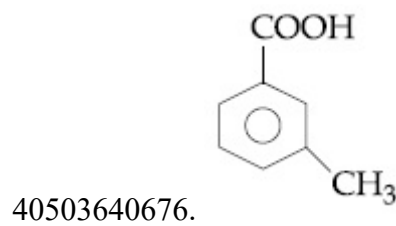
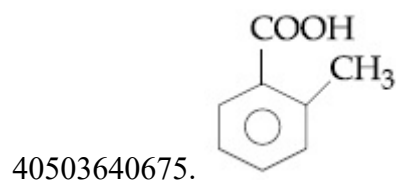
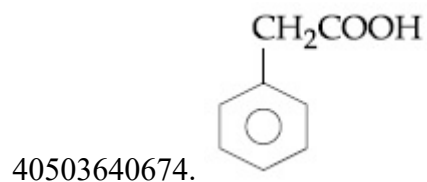

Question Number : 43 Question Id : 40503611198 Question Type : MCQ Option Shuffling : Yes Display Question Number : Yes Is Question Mandatory : No Single Line Question Option : No Option Orientation : Vertical Correct Marks : 4 Wrong Marks : 1

[P], CCl_4 में $\text{Br}_2/\text{FeBr}_3$ के साथ अभिकृत करने पर एक एकल समावयवी $\text{C}_8\text{H}_7\text{O}_2\text{Br}$ को दिया जब कि [P] सोडालाइम के साथ गरम करने पर टालूईन दिया। यौगिक [P] है :

Options :

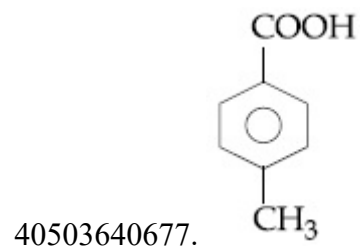
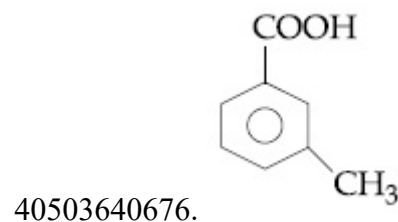
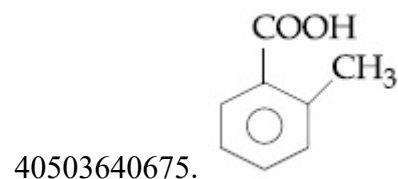
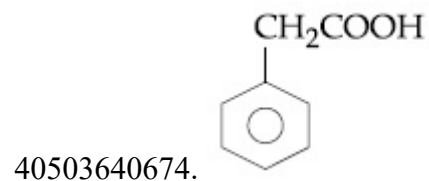

Question Number : 44 Question Id : 40503611199 Question Type : MCQ Option Shuffling : Yes Display Question Number : Yes Is
Question Mandatory : No Single Line Question Option : No Option Orientation : Vertical
Correct Marks : 4 Wrong Marks : 1

When neopentyl alcohol is heated with an acid, it slowly converted into an 85 : 15 mixture of alkenes A and B, respectively.

What are these alkenes ?

Options :

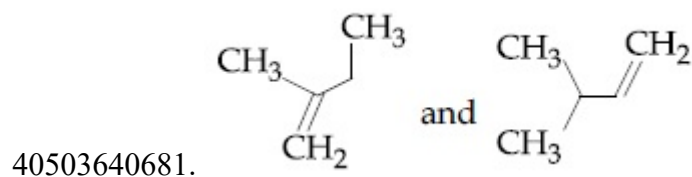
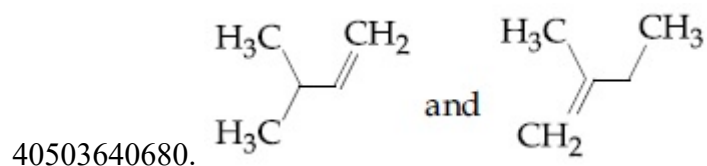
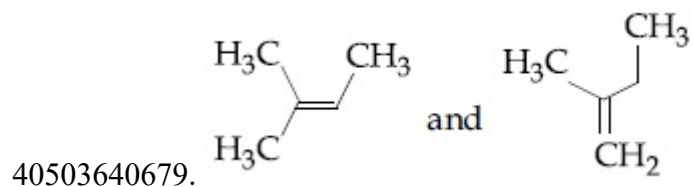
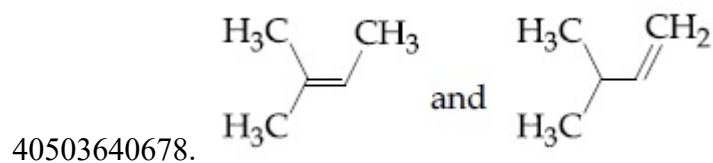

Question Number : 44 Question Id : 40503611199 Question Type : MCQ Option Shuffling : Yes Display Question Number : Yes Is Question Mandatory : No Single Line Question Option : No Option Orientation : Vertical Correct Marks : 4 Wrong Marks : 1

जब निओपेन्टाइल ऐल्कोहॉल को एक अम्ल के साथ गरम किया जाता है तब वह क्रमशः A तथा B ऐल्कीनों के 85 : 15 मिश्रण में धीरे-धीरे बदल जाता है। ये ऐल्कीन क्या हैं ?

Options :

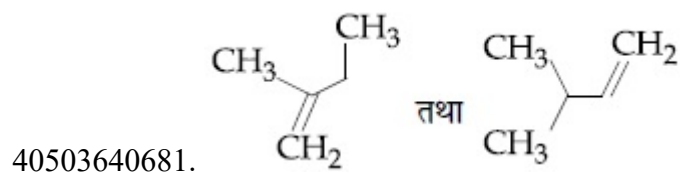
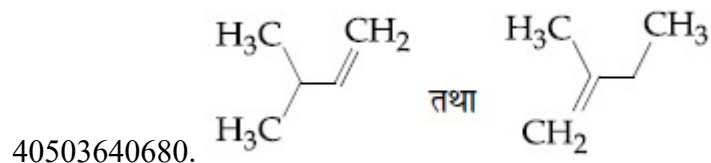
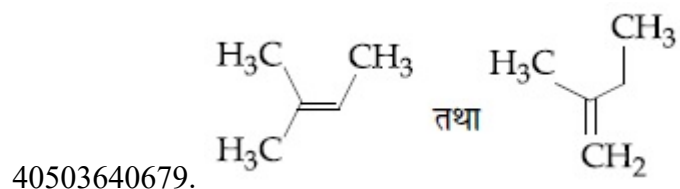
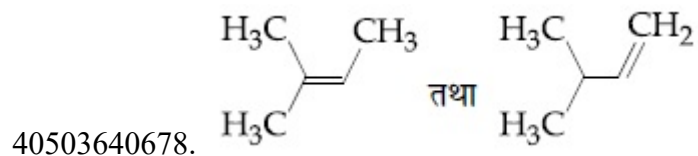

Question Number : 45 Question Id : 40503611200 Question Type : MCQ Option Shuffling : Yes Display Question Number : Yes Is Question Mandatory : No Single Line Question Option : No Option Orientation : Vertical

Correct Marks : 4 Wrong Marks : 1

Which of the following will react with $\text{CHCl}_3 + \text{alc. KOH}$?

Options :

40503640682. Adenine and proline
40503640683. Adenine and thymine
40503640684. Adenine and lysine
40503640685. Thymine and proline

Question Number : 45 Question Id : 40503611200 Question Type : MCQ Option Shuffling : Yes Display Question Number : Yes Is Question Mandatory : No Single Line Question Option : No Option Orientation : Vertical Correct Marks : 4 Wrong Marks : 1

निम्न में से कौन CHCl_3 + ऐल्कोहलिक KOH के साथ अभिक्रिया करेगा ?

Options :

40503640682. ऐडेनिन तथा प्रोलीन
40503640683. ऐडेनिन तथा थायमीन
40503640684. ऐडेनिन तथा लायसिन
40503640685. थायमीन तथा प्रोलीन

Sub-Section Number : 2
Sub-Section Id : 405036782
Question Shuffling Allowed : Yes

Question Number : 46 Question Id : 40503611201 Question Type : SA Display Question Number : Yes Correct Marks : 4 Wrong Marks : 0

The mass of ammonia in grams produced when 2.8 kg of dinitrogen quantitatively reacts with 1 kg of dihydrogen is

_____.

Response Type : Numeric

Evaluation Required For SA : Yes

Show Word Count : Yes

Answers Type : Range

Text Areas : PlainText

Possible Answers :

5 to 5.002

Question Number : 46 **Question Id :** 40503611201 **Question Type :** SA Display **Question Number :** Yes

Correct Marks : 4 **Wrong Marks :** 0

जब डाइनाइट्रोजन का 2.8 kg मात्रात्मक रूप से डाइहाइड्रोजन के 1 kg के साथ अभिक्रिया करता है तो पैदा होने वाली अमोनिया की मात्रा (ग्राम में) होगी

_____.

Response Type : Numeric

Evaluation Required For SA : Yes

Show Word Count : Yes

Answers Type : Range

Text Areas : PlainText

Possible Answers :

5 to 5.002

Question Number : 47 **Question Id :** 40503611202 **Question Type :** SA Display **Question Number :** Yes

Correct Marks : 4 **Wrong Marks :** 0

At 300 K, the vapour pressure of a solution containing 1 mole of n-hexane and 3 moles of n-heptane is 550 mm of Hg. At the same temperature, if one more mole of n-heptane is added to this solution, the vapour pressure of the solution increases by 10 mm of Hg. What is the vapour pressure in mm Hg of n-heptane in its pure state _____ ?

Response Type : Numeric

Evaluation Required For SA : Yes

Show Word Count : Yes

Answers Type : Range

Text Areas : PlainText

Possible Answers :

5 to 5.002

Question Number : 47 **Question Id :** 40503611202 **Question Type :** SA **Display Question Number :** Yes

Correct Marks : 4 **Wrong Marks :** 0

300 K पर, एक विलयन, जिसमें 1 मोल n-हेक्सेन तथा 3 मोल n-हेप्टेन हैं, का वाष्प दाब 550 mm Hg है। इसी ताप पर, यदि n-हेप्टेन के 1 मोल को विलयन में मिलाया जाय तो विलयन का वाष्प दाब 10 mm Hg से बढ़ जाता है। n-हेप्टेन का, इसकी विशुद्ध अवस्था में, वाष्प दाब (mm Hg में) क्या होगा _____ ?

Response Type : Numeric

Evaluation Required For SA : Yes

Show Word Count : Yes

Answers Type : Range

Text Areas : PlainText

Possible Answers :

5 to 5.002

Question Number : 48 Question Id : 40503611203 Question Type : SA Display Question Number : Yes

Correct Marks : 4 Wrong Marks : 0

If 75% of a first order reaction was completed in 90 minutes, 60% of the same reaction would be completed in approximately (in minutes) _____.

(Take : $\log 2 = 0.30$; $\log 2.5 = 0.40$)

Response Type : Numeric

Evaluation Required For SA : Yes

Show Word Count : Yes

Answers Type : Range

Text Areas : PlainText

Possible Answers :

5 to 5.002

Question Number : 48 Question Id : 40503611203 Question Type : SA Display Question Number : Yes

Correct Marks : 4 Wrong Marks : 0

यदि एक प्रथम कोटि की अभिक्रिया का 75%, 90 मिनटों में पूरा हो गया तो इसी अभिक्रिया का 60% पूरा होगा लगभग कितने मिनट में? _____.

(मानें : $\log 2 = 0.30$; $\log 2.5 = 0.40$)

Response Type : Numeric

Evaluation Required For SA : Yes

Show Word Count : Yes

Answers Type : Range

Text Areas : PlainText

Possible Answers :

5 to 5.002

Question Number : 49 Question Id : 40503611204 Question Type : SA Display Question Number : Yes

Correct Marks : 4 Wrong Marks : 0

A 20.0 mL solution containing 0.2 g impure H_2O_2 reacts completely with 0.316 g of KMnO_4 in acid solution. The purity of H_2O_2 (in %) is _____ (mol. wt. of $\text{H}_2\text{O}_2 = 34$; mol. wt. of $\text{KMnO}_4 = 158$)

Response Type : Numeric

Evaluation Required For SA : Yes

Show Word Count : Yes

Answers Type : Range

Text Areas : PlainText

Possible Answers :

5 to 5.002

Question Number : 49 Question Id : 40503611204 Question Type : SA Display Question Number : Yes

Correct Marks : 4 Wrong Marks : 0

20.0 mL विलयन जिसमें 0.2 g अशुद्ध H_2O_2 है, अम्लीय विलयन में KMnO_4 के 0.316 g के साथ पूर्णतया अभिक्रिया करता है। H_2O_2 की शुद्धता (% में) होगी _____.

(H_2O_2 का अणुभार = 34; KMnO_4 का अणुभार = 158)

Response Type : Numeric

Evaluation Required For SA : Yes

Show Word Count : Yes

Answers Type : Range

Text Areas : PlainText

Possible Answers :

5 to 5.002

Question Number : 50 Question Id : 40503611205 Question Type : SA Display Question Number : Yes

Correct Marks : 4 Wrong Marks : 0

The number of chiral centres present in [B]

is _____.

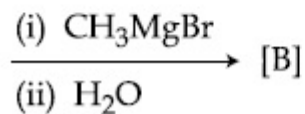
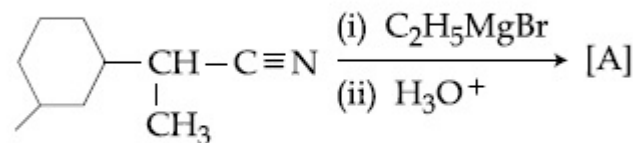

Response Type : Numeric

Evaluation Required For SA : Yes

Show Word Count : Yes

Answers Type : Range

Text Areas : PlainText

Possible Answers :

5 to 5.002

Question Number : 50 Question Id : 40503611205 Question Type : SA Display Question Number : Yes

Correct Marks : 4 Wrong Marks : 0

[B] में उपस्थित काइरल सेन्ट्रों की संख्या है

_____.

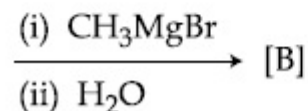
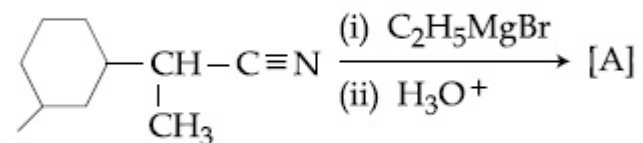

Response Type : Numeric

Evaluation Required For SA : Yes

Show Word Count : Yes

Answers Type : Range

Text Areas : PlainText

Possible Answers :

5 to 5.002

Mathematics

Section Id :	405036408
Section Number :	3
Section type :	Online
Mandatory or Optional :	Mandatory
Number of Questions :	25
Number of Questions to be attempted :	25
Section Marks :	100
Display Number Panel :	Yes
Group All Questions :	Yes
Mark As Answered Required? :	Yes
Sub-Section Number :	1
Sub-Section Id :	405036783

Question Shuffling Allowed :

Yes

Question Number : 51 Question Id : 40503611206 Question Type : MCQ Option Shuffling : Yes Display Question Number : Yes Is Question Mandatory : No Single Line Question Option : No Option Orientation : Vertical Correct Marks : 4 Wrong Marks : 1

A survey shows that 63% of the people in a city read newspaper A whereas 76% read newspaper B. If $x\%$ of the people read both the newspapers, then a possible value of x can be :

Options :

40503640691. 29

40503640692. 55

40503640693. 65

40503640694. 37

Question Number : 51 Question Id : 40503611206 Question Type : MCQ Option Shuffling : Yes Display Question Number : Yes Is Question Mandatory : No Single Line Question Option : No Option Orientation : Vertical Correct Marks : 4 Wrong Marks : 1

एक सर्वेक्षण दर्शाता है कि एक शहर में 63% लोग समाचार पत्र A पढ़ते हैं, जबकि 76% समाचार पत्र B पढ़ते हैं। यदि $x\%$ लोग दोनों समाचार पत्र पढ़ते हैं, तो x का एक सम्भावित मान हो सकता है :

Options :

40503640691. 29

40503640692. 55

40503640693. 65

40503640694. 37

Question Number : 52 Question Id : 40503611207 Question Type : MCQ Option Shuffling : Yes Display Question Number : Yes Is Question Mandatory : No Single Line Question Option : No Option Orientation : Vertical

Correct Marks : 4 Wrong Marks : 1

Let $[t]$ denote the greatest integer $\leq t$. Then the equation in x , $[x]^2 + 2[x + 2] - 7 = 0$ has :

Options :

40503640695. no integral solution.

40503640696. exactly two solutions.

40503640697. exactly four integral solutions.

40503640698. infinitely many solutions.

Question Number : 52 Question Id : 40503611207 Question Type : MCQ Option Shuffling : Yes Display Question Number : Yes Is Question Mandatory : No Single Line Question Option : No Option Orientation : Vertical

Correct Marks : 4 Wrong Marks : 1

यदि $[t]$ महत्तम पूर्णांक $\leq t$ दर्शाता है, तो x में समीकरण,
 $[x]^2 + 2[x + 2] - 7 = 0$

Options :

40503640695. का कोई पूर्णाकीय हल नहीं है।

40503640696. के मात्र दो हल हैं।

40503640697. के मात्र चार पूर्णाकीय हल हैं।

40503640698. के अनन्त हल हैं।

Question Number : 53 Question Id : 40503611208 Question Type : MCQ Option Shuffling : Yes Display Question Number : Yes Is Question Mandatory : No Single Line Question Option : No Option Orientation : Vertical

Correct Marks : 4 Wrong Marks : 1

Let $u = \frac{2z + i}{z - ki}$, $z = x + iy$ and $k > 0$. If the

curve represented by $\text{Re}(u) + \text{Im}(u) = 1$ intersects the y -axis at the points P and Q where $PQ = 5$, then the value of k is :

Options :

40503640699. $1/2$

40503640700. 2

40503640701. $3/2$

40503640702. 4

Question Number : 53 Question Id : 40503611208 Question Type : MCQ Option Shuffling : Yes Display Question Number : Yes Is Question Mandatory : No Single Line Question Option : No Option Orientation : Vertical

Correct Marks : 4 Wrong Marks : 1

माना $u = \frac{2z + i}{z - ki}$, $z = x + iy$ तथा $k > 0$ हैं। यदि

$\text{Re}(u) + \text{Im}(u) = 1$ द्वारा निरूपित वक्र, y -अक्ष को P तथा Q पर काटता है, जबकि $PQ = 5$ है, तो k बराबर है :

Options :

40503640699. $1/2$

40503640700. 2

40503640701. $3/2$

40503640702. 4

Question Number : 54 Question Id : 40503611209 Question Type : MCQ Option Shuffling : Yes Display Question Number : Yes Is Question Mandatory : No Single Line Question Option : No Option Orientation : Vertical

Correct Marks : 4 Wrong Marks : 1

If $A = \begin{bmatrix} \cos\theta & i\sin\theta \\ i\sin\theta & \cos\theta \end{bmatrix}$, $\left(\theta = \frac{\pi}{24}\right)$ and

$A^5 = \begin{bmatrix} a & b \\ c & d \end{bmatrix}$, where $i = \sqrt{-1}$, then

which one of the following is not true ?

Options :

40503640703. $a^2 - d^2 = 0$

40503640704. $a^2 - b^2 = \frac{1}{2}$

40503640705. $0 \leq a^2 + b^2 \leq 1$

40503640706. $a^2 - c^2 = 1$

Question Number : 54 Question Id : 40503611209 Question Type : MCQ Option Shuffling : Yes Display Question Number : Yes Is Question Mandatory : No Single Line Question Option : No Option Orientation : Vertical Correct Marks : 4 Wrong Marks : 1

यदि $A = \begin{bmatrix} \cos\theta & i\sin\theta \\ i\sin\theta & \cos\theta \end{bmatrix}$, $\left(\theta = \frac{\pi}{24}\right)$ तथा

$A^5 = \begin{bmatrix} a & b \\ c & d \end{bmatrix}$, जबकि $i = \sqrt{-1}$ है, तो निम्न में

से कौन-सा सत्य नहीं है?

Options :

40503640703. $a^2 - d^2 = 0$

40503640704. $a^2 - b^2 = \frac{1}{2}$

40503640705. $0 \leq a^2 + b^2 \leq 1$

40503640706. $a^2 - c^2 = 1$

Question Number : 55 Question Id : 40503611210 Question Type : MCQ Option Shuffling : Yes Display Question Number :

Question Mandatory : No Single Line Question Option : No Option Orientation : Vertical

Correct Marks : 4 Wrong Marks : 1

The value of $\sum_{r=0}^{20} {}^{50-r}C_6$ is equal to :

Options :

40503640707. ${}^{50}C_6 - {}^{30}C_6$

40503640708. ${}^{50}C_7 - {}^{30}C_7$

40503640709. ${}^{51}C_7 - {}^{30}C_7$

40503640710. ${}^{51}C_7 + {}^{30}C_7$

Question Number : 55 Question Id : 40503611210 Question Type : MCQ Option Shuffling : Yes Display Question Number : Yes Is

Question Mandatory : No Single Line Question Option : No Option Orientation : Vertical

Correct Marks : 4 Wrong Marks : 1

$\sum_{r=0}^{20} {}^{50-r}C_6$ बराबर है :

Options :

40503640707. ${}^{50}C_6 - {}^{30}C_6$

40503640708. ${}^{50}C_7 - {}^{30}C_7$

40503640709. ${}^{51}C_7 - {}^{30}C_7$

40503640710. ${}^{51}C_7 + {}^{30}C_7$

Question Number : 56 Question Id : 40503611211 Question Type : MCQ Option Shuffling : Yes Display Question Number : Yes Is Question Mandatory : No Single Line Question Option : No Option Orientation : Vertical Correct Marks : 4 Wrong Marks : 1

Let α and β be the roots of $x^2 - 3x + p = 0$
and γ and δ be the roots of $x^2 - 6x + q = 0$.
If $\alpha, \beta, \gamma, \delta$ form a geometric progression.
Then ratio $(2q + p) : (2q - p)$ is :

Options :

40503640711. 33 : 31

40503640712. 9 : 7

40503640713. 5 : 3

40503640714. 3 : 1

Question Number : 56 Question Id : 40503611211 Question Type : MCQ Option Shuffling : Yes Display Question Number : Yes Is Question Mandatory : No Single Line Question Option : No Option Orientation : Vertical Correct Marks : 4 Wrong Marks : 1

माना α तथा β , समीकरण $x^2 - 3x + p = 0$ के मूल हैं
और γ तथा δ , समीकरण $x^2 - 6x + q = 0$ के मूल हैं।
यदि α, β, γ तथा δ गुणोत्तर श्रेणी में हैं, तो अनुपात,
 $(2q + p) : (2q - p)$ है :

Options :

40503640711. 33 : 31

40503640712. 9 : 7

40503640713. 5 : 3

40503640714. 3 : 1

Question Number : 57 Question Id : 40503611212 Question Type : MCQ Option Shuffling : Yes Display Question Number : Yes Is Question Mandatory : No Single Line Question Option : No Option Orientation : Vertical Correct Marks : 4 Wrong Marks : 1

If

$1 + (1 - 2^2 \cdot 1) + (1 - 4^2 \cdot 3) + (1 - 6^2 \cdot 5) + \dots + (1 - 20^2 \cdot 19) = \alpha - 220\beta$, then an ordered pair (α, β) is equal to :

Options :

40503640715. (10, 97)

40503640716. (10, 103)

40503640717. (11, 103)

40503640718. (11, 97)

Question Number : 57 Question Id : 40503611212 Question Type : MCQ Option Shuffling : Yes Display Question Number : Yes Is Question Mandatory : No Single Line Question Option : No Option Orientation : Vertical Correct Marks : 4 Wrong Marks : 1

यदि

$1 + (1 - 2^2 \cdot 1) + (1 - 4^2 \cdot 3) + (1 - 6^2 \cdot 5) + \dots + (1 - 20^2 \cdot 19) = \alpha - 220\beta$, तो एक क्रमित युग्म (α, β) बराबर है :

Options :

40503640715. (10, 97)

40503640716. (10, 103)

40503640717. (11, 103)

40503640718. (11, 97)

Question Number : 58 Question Id : 40503611213 Question Type : MCQ Option Shuffling : Yes Display Question Number : Yes Is Question Mandatory : No Single Line Question Option : No Option Orientation : Vertical

Correct Marks : 4 Wrong Marks : 1

Let f be a twice differentiable function on $(1, 6)$. If $f(2) = 8$, $f'(2) = 5$, $f'(x) \geq 1$ and $f''(x) \geq 4$, for all $x \in (1, 6)$, then :

Options :

40503640719. $f(5) \leq 10$

40503640720. $f(5) + f'(5) \geq 28$

40503640721. $f'(5) + f''(5) \leq 20$

40503640722. $f(5) + f'(5) \leq 26$

Question Number : 58 Question Id : 40503611213 Question Type : MCQ Option Shuffling : Yes Display Question Number : Yes Is Question Mandatory : No Single Line Question Option : No Option Orientation : Vertical

Correct Marks : 4 Wrong Marks : 1

माना फलन f , अन्तराल $(1, 6)$ में दो बार अवकलनीय है। यदि $f(2) = 8, f'(2) = 5$, तथा सभी $x \in (1, 6)$ के लिए $f'(x) \geq 1$ तथा $f''(x) \geq 4$ हैं, तो :

Options :

40503640719. $f(5) \leq 10$

40503640720. $f(5) + f'(5) \geq 28$

40503640721. $f'(5) + f''(5) \leq 20$

40503640722. $f(5) + f'(5) \leq 26$

Question Number : 59 Question Id : 40503611214 Question Type : MCQ Option Shuffling : Yes Display Question Number : Yes Is Question Mandatory : No Single Line Question Option : No Option Orientation : Vertical

Correct Marks : 4 Wrong Marks : 1

If $(a + \sqrt{2} b \cos x)(a - \sqrt{2} b \cos y) = a^2 - b^2$,

where $a > b > 0$, then $\frac{dx}{dy}$ at $\left(\frac{\pi}{4}, \frac{\pi}{4}\right)$ is :

Options :

40503640723. $\frac{a - b}{a + b}$

40503640724. $\frac{2a + b}{2a - b}$

40503640725. $\frac{a + b}{a - b}$

40503640726. $\frac{a - 2b}{a + 2b}$

Question Number : 59 Question Id : 40503611214 Question Type : MCQ Option Shuffling : Yes Display Question Number : Yes Is Question Mandatory : No Single Line Question Option : No Option Orientation : Vertical Correct Marks : 4 Wrong Marks : 1

यदि $(a + \sqrt{2} b \cos x)$

$(a - \sqrt{2} b \cos y) = a^2 - b^2$, जहाँ $a > b > 0$ हैं,

तो $\left(\frac{\pi}{4}, \frac{\pi}{4}\right)$ पर $\frac{dx}{dy}$ बराबर है :

Options :

40503640723. $\frac{a - b}{a + b}$

40503640724. $\frac{2a + b}{2a - b}$

40503640725. $\frac{a + b}{a - b}$

$$\frac{a - 2b}{a + 2b}$$

40503640726.

Question Number : 60 Question Id : 40503611215 Question Type : MCQ Option Shuffling : Yes Display Question Number : Yes Is Question Mandatory : No Single Line Question Option : No Option Orientation : Vertical Correct Marks : 4 Wrong Marks : 1

Let $f(x) = |x - 2|$ and $g(x) = f(f(x))$, $x \in [0, 4]$.

Then $\int_0^3 (g(x) - f(x)) dx$ is equal to :

Options :

40503640727. 0

40503640728. $\frac{1}{2}$

40503640729. 1

40503640730. $\frac{3}{2}$

Question Number : 60 Question Id : 40503611215 Question Type : MCQ Option Shuffling : Yes Display Question Number : Yes Is Question Mandatory : No Single Line Question Option : No Option Orientation : Vertical Correct Marks : 4 Wrong Marks : 1

यदि $x \in [0, 4]$ के लिए $f(x) = |x - 2|$ तथा

$g(x) = f(f(x))$ हैं, तो $\int_0^3 (g(x) - f(x)) dx$ बराबर

है :

Options :

40503640727. 0

40503640728. $\frac{1}{2}$

40503640729. 1

40503640730. $\frac{3}{2}$

Question Number : 61 Question Id : 40503611216 Question Type : MCQ Option Shuffling : Yes Display Question Number : Yes Is Question Mandatory : No Single Line Question Option : No Option Orientation : Vertical

Correct Marks : 4 Wrong Marks : 1

The integral $\int \left(\frac{x}{x \sin x + \cos x} \right)^2 dx$ is equal

to

(where C is a constant of integration) :

Options :

40503640731. $\sec x + \frac{x \tan x}{x \sin x + \cos x} + C$

40503640732. $\sec x - \frac{x \tan x}{x \sin x + \cos x} + C$

40503640733. $\tan x + \frac{x \sec x}{x \sin x + \cos x} + C$

40503640734. $\tan x - \frac{x \sec x}{x \sin x + \cos x} + C$

Question Number : 61 Question Id : 40503611216 Question Type : MCQ Option Shuffling : Yes Display Question Number : Yes Is Question Mandatory : No Single Line Question Option : No Option Orientation : Vertical

Correct Marks : 4 Wrong Marks : 1

समाकलन $\int \left(\frac{x}{x \sin x + \cos x} \right)^2 dx$ बराबर है

(जहाँ C एक समाकलन अचर है) :

Options :

40503640731. $\sec x + \frac{x \tan x}{x \sin x + \cos x} + C$

40503640732. $\sec x - \frac{x \tan x}{x \sin x + \cos x} + C$

40503640733. $\tan x + \frac{x \sec x}{x \sin x + \cos x} + C$

40503640734. $\tan x - \frac{x \sec x}{x \sin x + \cos x} + C$

Question Number : 62 Question Id : 40503611217 Question Type : MCQ Option Shuffling : Yes Display Question Number : Yes Is Question Mandatory : No Single Line Question Option : No Option Orientation : Vertical

Correct Marks : 4 Wrong Marks : 1

Let $f(x) = \int \frac{\sqrt{x}}{(1+x)^2} dx$ ($x \geq 0$). Then

$f(3) - f(1)$ is equal to :

Options :

40503640735. $-\frac{\pi}{12} + \frac{1}{2} + \frac{\sqrt{3}}{4}$

40503640736. $\frac{\pi}{12} + \frac{1}{2} - \frac{\sqrt{3}}{4}$

40503640737. $\frac{\pi}{6} + \frac{1}{2} - \frac{\sqrt{3}}{4}$

40503640738. $-\frac{\pi}{6} + \frac{1}{2} + \frac{\sqrt{3}}{4}$

Question Number : 62 Question Id : 40503611217 Question Type : MCQ Option Shuffling : Yes Display Question Number : Yes Is Question Mandatory : No Single Line Question Option : No Option Orientation : Vertical

Correct Marks : 4 Wrong Marks : 1

यदि $f(x) = \int \frac{\sqrt{x}}{(1+x)^2} dx$ ($x \geq 0$) है, तो

$f(3) - f(1)$ बराबर है :

Options :

40503640735. $-\frac{\pi}{12} + \frac{1}{2} + \frac{\sqrt{3}}{4}$

40503640736. $\frac{\pi}{12} + \frac{1}{2} - \frac{\sqrt{3}}{4}$

40503640737. $\frac{\pi}{6} + \frac{1}{2} - \frac{\sqrt{3}}{4}$

40503640738. $-\frac{\pi}{6} + \frac{1}{2} + \frac{\sqrt{3}}{4}$

Question Number : 63 Question Id : 40503611218 Question Type : MCQ Option Shuffling : Yes Display Question Number : Yes Is Question Mandatory : No Single Line Question Option : No Option Orientation : Vertical Correct Marks : 4 Wrong Marks : 1

Let $y = y(x)$ be the solution of the differential equation,

$$xy' - y = x^2(x \cos x + \sin x), \quad x > 0. \quad \text{If}$$

$y(\pi) = \pi$, then $y''\left(\frac{\pi}{2}\right) + y\left(\frac{\pi}{2}\right)$ is equal to :

Options :

40503640739. $1 + \frac{\pi}{2}$

40503640740. $1 + \frac{\pi}{2} + \frac{\pi^2}{4}$

40503640741. $2 + \frac{\pi}{2}$

40503640742. $2 + \frac{\pi}{2} + \frac{\pi^2}{4}$

Question Number : 63 Question Id : 40503611218 Question Type : MCQ Option Shuffling : Yes Display Question Number : Yes Is Question Mandatory : No Single Line Question Option : No Option Orientation : Vertical Correct Marks : 4 Wrong Marks : 1

माना अवकल समीकरण

$xy' - y = x^2(x\cos x + \sin x), x > 0$ का हल $y = y(x)$

है। यदि $y(\pi) = \pi$ है, तो $y''\left(\frac{\pi}{2}\right) + y\left(\frac{\pi}{2}\right)$ बराबर

है :

Options :

40503640739. $1 + \frac{\pi}{2}$

40503640740. $1 + \frac{\pi}{2} + \frac{\pi^2}{4}$

40503640741. $2 + \frac{\pi}{2}$

40503640742. $2 + \frac{\pi}{2} + \frac{\pi^2}{4}$

Question Number : 64 Question Id : 40503611219 Question Type : MCQ Option Shuffling : Yes Display Question Number : Yes Is Question Mandatory : No Single Line Question Option : No Option Orientation : Vertical

Correct Marks : 4 Wrong Marks : 1

A triangle ABC lying in the first quadrant has two vertices as A(1, 2) and B(3, 1).

If $\angle BAC = 90^\circ$, and $\text{ar}(\Delta ABC) = 5\sqrt{5}$ sq. units, then the abscissa of the vertex C is :

Options :

40503640743. $1 + 2\sqrt{5}$

40503640744. $1 + \sqrt{5}$

40503640745. $2 + \sqrt{5}$

40503640746. $2\sqrt{5} - 1$

Question Number : 64 Question Id : 40503611219 Question Type : MCQ Option Shuffling : Yes Display Question Number : Yes Is Question Mandatory : No Single Line Question Option : No Option Orientation : Vertical

Correct Marks : 4 Wrong Marks : 1

एक त्रिभुज ABC, जो प्रथम चतुर्थांश में स्थित है, के दो शीर्ष बिन्दु A(1, 2) तथा B(3, 1) हैं। यदि $\angle BAC = 90^\circ$ तथा $\text{ar}(\Delta ABC) = 5\sqrt{5}$ वर्ग इकाई है, तो शीर्ष बिन्दु C का भुज (Abscissa) है :

Options :

40503640743. $1 + 2\sqrt{5}$

40503640744. $1 + \sqrt{5}$

40503640745. $2 + \sqrt{5}$

40503640746. $2\sqrt{5} - 1$

Question Number : 65 Question Id : 40503611220 Question Type : MCQ Option Shuffling : Yes Display Question Number : Yes Is Question Mandatory : No Single Line Question Option : No Option Orientation : Vertical Correct Marks : 4 Wrong Marks : 1

Let $\frac{x^2}{a^2} + \frac{y^2}{b^2} = 1$ ($a > b$) be a given ellipse,

length of whose latus rectum is 10. If its eccentricity is the maximum value of the

function, $\phi(t) = \frac{5}{12} + t - t^2$, then $a^2 + b^2$

is equal to :

Options :

40503640747. 116

40503640748. 126

40503640749. 135

40503640750. 145

Question Number : 65 Question Id : 40503611220 Question Type : MCQ Option Shuffling : Yes Display Question Number :

Question Mandatory : No Single Line Question Option : No Option Orientation : Vertical

Correct Marks : 4 Wrong Marks : 1

माना $\frac{x^2}{a^2} + \frac{y^2}{b^2} = 1$ ($a > b$) एक दीर्घवृत्त दिया है

जिस के नाभिलम्ब जीवा की लम्बाई 10 है। यदि इस

की उत्केन्द्रता, फलन $\phi(t) = \frac{5}{12} + t - t^2$ के

अधिकतम मान के बराबर है, तो $a^2 + b^2$ बराबर है :

Options :

40503640747. 116

40503640748. 126

40503640749. 135

40503640750. 145

Question Number : 66 Question Id : 40503611221 Question Type : MCQ Option Shuffling : Yes Display Question Number : Yes Is

Question Mandatory : No Single Line Question Option : No Option Orientation : Vertical

Correct Marks : 4 Wrong Marks : 1

Let $P(3, 3)$ be a point on the hyperbola,

$\frac{x^2}{a^2} - \frac{y^2}{b^2} = 1$. If the normal to it at P

intersects the x -axis at $(9, 0)$ and e is its

eccentricity, then the ordered pair (a^2, e^2)

is equal to :

Options :

40503640751. $\left(\frac{9}{2}, 2\right)$

40503640752. $(9, 3)$

40503640753. $\left(\frac{3}{2}, 2\right)$

40503640754. $\left(\frac{9}{2}, 3\right)$

Question Number : 66 Question Id : 40503611221 Question Type : MCQ Option Shuffling : Yes Display Question Number : Yes Is Question Mandatory : No Single Line Question Option : No Option Orientation : Vertical

Correct Marks : 4 Wrong Marks : 1

माना बिन्दु $P(3, 3)$ अतिपरवलय, $\frac{x^2}{a^2} - \frac{y^2}{b^2} = 1$

पर स्थित है। यदि P पर इसका अभिलंब, x -अक्ष को बिन्दु $(9, 0)$ पर काटता है तथा इसकी उत्केन्द्रता e के बराबर है, तो क्रमित युग्म (a^2, e^2) बराबर है :

Options :

40503640751. $\left(\frac{9}{2}, 2\right)$

40503640752. $(9, 3)$

40503640753. $\left(\frac{3}{2}, 2\right)$

40503640754. $\left(\frac{9}{2}, 3\right)$

Question Number : 67 Question Id : 40503611222 Question Type : MCQ Option Shuffling : Yes Display Question Number : Yes Is Question Mandatory : No Single Line Question Option : No Option Orientation : Vertical

Correct Marks : 4 Wrong Marks : 1

Let x_0 be the point of local maxima of

$$f(x) = \vec{a} \cdot (\vec{b} \times \vec{c}), \quad \text{where}$$

$$\vec{a} = x\hat{i} - 2\hat{j} + 3\hat{k}, \quad \vec{b} = -2\hat{i} + x\hat{j} - \hat{k}$$

and $\vec{c} = 7\hat{i} - 2\hat{j} + x\hat{k}$. Then the value

of $\vec{a} \cdot \vec{b} + \vec{b} \cdot \vec{c} + \vec{c} \cdot \vec{a}$ at $x=x_0$ is :

Options :

40503640755. -30

40503640756. -22

40503640757. -4

40503640758. 14

Question Number : 67 Question Id : 40503611222 Question Type : MCQ Option Shuffling : Yes Display Question Number : Yes Is Question Mandatory : No Single Line Question Option : No Option Orientation : Vertical

Correct Marks : 4 Wrong Marks : 1

यदि x_0 , फलन $f(x) = \vec{a} \cdot (\vec{b} \times \vec{c})$ का स्थानीय

उच्चिष्ठ है, जहाँ $\vec{a} = x\hat{i} - 2\hat{j} + 3\hat{k}$,

$\vec{b} = -2\hat{i} + x\hat{j} - \hat{k}$ तथा

$\vec{c} = 7\hat{i} - 2\hat{j} + x\hat{k}$ हैं, तो $x = x_0$ पर

$\vec{a} \cdot \vec{b} + \vec{b} \cdot \vec{c} + \vec{c} \cdot \vec{a}$ का मान है :

Options :

40503640755. -30

40503640756. -22

40503640757. -4

40503640758. 14

Question Number : 68 Question Id : 40503611223 Question Type : MCQ Option Shuffling : Yes Display Question Number : Yes Is Question Mandatory : No Single Line Question Option : No Option Orientation : Vertical

Correct Marks : 4 Wrong Marks : 1

The mean and variance of 8 observations are 10 and 13.5, respectively. If 6 of these observations are 5, 7, 10, 12, 14, 15, then the absolute difference of the remaining two observations is :

Options :

40503640759. 3

40503640760. 5

40503640761. 7

40503640762. 9

Question Number : 68 Question Id : 40503611223 Question Type : MCQ Option Shuffling : Yes Display Question Number : Yes Is Question Mandatory : No Single Line Question Option : No Option Orientation : Vertical Correct Marks : 4 Wrong Marks : 1

8 प्रेक्षणों का माध्य तथा प्रसरण क्रमशः 10 तथा 13.5 हैं। यदि इनमें से 6 प्रेक्षण 5, 7, 10, 12, 14 तथा 15 हैं, तो बाकी दो प्रेक्षणों का निरपेक्ष अंतर है :

Options :

40503640759. 3

40503640760. 5

40503640761. 7

40503640762. 9

Question Number : 69 Question Id : 40503611224 Question Type : MCQ Option Shuffling : Yes Display Question Number : Yes Is Question Mandatory : No Single Line Question Option : No Option Orientation : Vertical Correct Marks : 4 Wrong Marks : 1

Two vertical poles $AB = 15$ m and $CD = 10$ m are standing apart on a horizontal ground with points A and C on the ground. If P is the point of intersection of BC and AD, then the height of P (in m) above the line AC is :

Options :

40503640763. 6

40503640764. $10/3$

40503640765. $20/3$

40503640766. 5

Question Number : 69 Question Id : 40503611224 Question Type : MCQ Option Shuffling : Yes Display Question Number : Yes Is Question Mandatory : No Single Line Question Option : No Option Orientation : Vertical

Correct Marks : 4 Wrong Marks : 1

दो सीधे खंभे $AB = 15$ m तथा $CD = 10$ m, क्षैतिज भूमि पर इस प्रकार खड़े हैं कि A तथा C भूमि पर हैं। यदि BC तथा AD का प्रतिच्छेदन बिन्दु P है, तो रेखा AC से P की ऊँचाई (m में) है :

Options :

40503640763. 6

40503640764. $10/3$

40503640765. $20/3$

40503640766. 5

Question Number : 70 Question Id : 40503611225 Question Type : MCQ Option Shuffling : Yes Display Question Number : Yes Is Question Mandatory : No Single Line Question Option : No Option Orientation : Vertical

Correct Marks : 4 Wrong Marks : 1

Given the following two statements :

(S₁) : $(q \vee p) \rightarrow (p \leftrightarrow \sim q)$ is a tautology.

(S₂) : $\sim q \wedge (\sim p \leftrightarrow q)$ is a fallacy. Then :

Options :

40503640767. both (S₁) and (S₂) are correct.

40503640768. only (S₁) is correct.

40503640769. only (S₂) is correct.

40503640770. both (S₁) and (S₂) are not correct.

Question Number : 70 Question Id : 40503611225 Question Type : MCQ Option Shuffling : Yes Display Question Number : Yes Is Question Mandatory : No Single Line Question Option : No Option Orientation : Vertical

Correct Marks : 4 Wrong Marks : 1

निम्न दो कथन दिए गए हैं :

(S₁) : $(q \vee p) \rightarrow (p \leftrightarrow \sim q)$ एक पुनरुक्ति है।

(S₂) : $\sim q \wedge (\sim p \leftrightarrow q)$ एक विरोधुक्ति है। तो :

Options :

40503640767. (S_1) तथा (S_2) दोनों सही हैं।

40503640768. केवल (S_1) सही है।

40503640769. केवल (S_2) सही है।

40503640770. (S_1) तथा (S_2) दोनों सही नहीं हैं।

Sub-Section Number : 2
Sub-Section Id : 405036784
Question Shuffling Allowed : Yes

Question Number : 71 Question Id : 40503611226 Question Type : SA Display Question Number : Yes
Correct Marks : 4 Wrong Marks : 0

If the system of equations

$$x - 2y + 3z = 9$$

$$2x + y + z = b$$

$x - 7y + az = 24$, has infinitely many solutions, then $a - b$ is equal to _____.

Response Type : Numeric
Evaluation Required For SA : Yes
Show Word Count : Yes
Answers Type : Range
Text Areas : PlainText
Possible Answers :
5 to 5.002

Question Number : 71 Question Id : 40503611226 Question Type : SA Display Question Number : Yes
Correct Marks : 4 Wrong Marks : 0

यदि समीकरण निकाय

$$x - 2y + 3z = 9$$

$$2x + y + z = b$$

$$x - 7y + az = 24$$

के अनन्त हल हैं तो $a - b$ बराबर है _____ ।

Response Type : Numeric

Evaluation Required For SA : Yes

Show Word Count : Yes

Answers Type : Range

Text Areas : PlainText

Possible Answers :

5 to 5.002

Question Number : 72 **Question Id :** 40503611227 **Question Type :** SA **Display Question Number :** Yes

Correct Marks : 4 **Wrong Marks :** 0

Let $(2x^2 + 3x + 4)^{10} = \sum_{r=0}^{20} a_r x^r$. Then

$\frac{a_7}{a_{13}}$ is equal to _____.

Response Type : Numeric

Evaluation Required For SA : Yes

Show Word Count : Yes

Answers Type : Range

Text Areas : PlainText

Possible Answers :

5 to 5.002

Question Number : 72 **Question Id :** 40503611227 **Question Type :** SA **Display Question Number :** Yes

Correct Marks : 4 Wrong Marks : 0

यदि $(2x^2 + 3x + 4)^{10} = \sum_{r=0}^{20} a_r x^r$, तो $\frac{a_7}{a_{13}}$

बराबर है _____।

Response Type : Numeric

Evaluation Required For SA : Yes

Show Word Count : Yes

Answers Type : Range

Text Areas : PlainText

Possible Answers :

5 to 5.002

Question Number : 73 Question Id : 40503611228 Question Type : SA Display Question Number : Yes

Correct Marks : 4 Wrong Marks : 0

Suppose a differentiable function $f(x)$ satisfies the identity $f(x+y) = f(x) + f(y) + xy^2 + x^2y$, for all real x and y . If $\lim_{x \rightarrow 0} \frac{f(x)}{x} = 1$, then $f'(3)$ is equal to _____.

Response Type : Numeric

Evaluation Required For SA : Yes

Show Word Count : Yes

Answers Type : Range

Text Areas : PlainText

Possible Answers :

5 to 5.002

Question Number : 73 Question Id : 40503611228 Question Type : SA Display Question Number : Yes

Correct Marks : 4 Wrong Marks : 0

माना सभी वास्तविक संख्याओं x तथा y के लिए, एक अवकलनीय फलन $f(x)$, सर्वसमिका (identity) $f(x + y) = f(x) + f(y) + xy^2 + x^2y$ को संतुष्ट करता है। यदि $\lim_{x \rightarrow 0} \frac{f(x)}{x} = 1$, तो $f(3)$ बराबर है _____।

Response Type : Numeric

Evaluation Required For SA : Yes

Show Word Count : Yes

Answers Type : Range

Text Areas : PlainText

Possible Answers :

5 to 5.002

Question Number : 74 Question Id : 40503611229 Question Type : SA Display Question Number : Yes

Correct Marks : 4 Wrong Marks : 0

If the equation of a plane P, passing through the intersection of the planes, $x + 4y - z + 7 = 0$ and $3x + y + 5z = 8$ is $ax + by + 6z = 15$ for some $a, b \in \mathbb{R}$, then the distance of the point $(3, 2, -1)$ from the plane P is _____.

Response Type : Numeric

Evaluation Required For SA : Yes

Show Word Count : Yes

Answers Type : Range

Text Areas : PlainText

Possible Answers :

5 to 5.002

Question Number : 74 Question Id : 40503611229 Question Type : SA Display Question Number : Yes

Correct Marks : 4 Wrong Marks : 0

किन्हीं $a, b \in \mathbb{R}$ के लिए, समतल P का समीकरण, जो समतलों, $x + 4y - z + 7 = 0$ तथा $3x + y + 5z = 8$ के प्रतिच्छेदन से होकर जाता है, $ax + by + 6z = 15$ है, तो बिन्दु $(3, 2, -1)$ की समतल P से दूरी बराबर है _____।

Response Type : Numeric

Evaluation Required For SA : Yes

Show Word Count : Yes

Answers Type : Range

Text Areas : PlainText

Possible Answers :

5 to 5.002

Question Number : 75 Question Id : 40503611230 Question Type : SA Display Question Number : Yes

Correct Marks : 4 Wrong Marks : 0

The probability of a man hitting a target is

$\frac{1}{10}$. The least number of shots required,

so that the probability of his hitting the

target at least once is greater than $\frac{1}{4}$,

is _____.

Response Type : Numeric

Evaluation Required For SA : Yes

Show Word Count : Yes

Answers Type : Range

Text Areas : PlainText

Possible Answers :

5 to 5.002

Question Number : 75 **Question Id :** 40503611230 **Question Type :** SA **Display Question Number :** Yes

Correct Marks : 4 **Wrong Marks :** 0

एक व्यक्ति के एक लक्ष्य को भेदने की प्रायिकता

$\frac{1}{10}$ है। उसके कम से कम एक बार लक्ष्य को भेदने

की प्रायिकता $\frac{1}{4}$ से अधिक होने के लिये, आवश्यक

शॉटों (shots) की कम से कम संख्या है

_____।

Response Type : Numeric

Evaluation Required For SA : Yes

Show Word Count : Yes

Answers Type : Range

Text Areas : PlainText

Possible Answers :

5 to 5.002