

Question Paper Preview

Question Paper Name :	Electrical and Electronics Engineering 14th Sep 2020 S1
Subject Name :	Electrical and Electronics Engineering
Duration :	180
Total Marks :	200
Display Marks:	No
Share Answer Key With Delivery Engine :	Yes
Actual Answer Key :	Yes
Is this Group for Examiner? :	No

Mathematics

Section Number :	1
Mandatory or Optional :	Mandatory
Number of Questions :	50
Number of Questions to be attempted :	50
Section Marks :	50
Display Number Panel :	Yes
Group All Questions :	Yes
Mark As Answered Required? :	Yes

**Question Number : 1 Question Id : 61097513829 Question Type : MCQ Display Question
Number : Yes Is Question Mandatory : No Single Line Question Option : No Option
Orientation : Vertical**

If $\begin{vmatrix} 15 - x & 11 & 10 \\ 11 - 3x & 17 & 16 \\ 7 - x & 14 & 13 \end{vmatrix} = 0$ then the value of x is

Options :

1. 6

2. 5

3. 7

4. -6

Question Number : 2 Question Id : 61097513830 Question Type : MCQ Display Question

Number : Yes Is Question Mandatory : No Single Line Question Option : No Option

Orientation : Vertical

The co-factors of the elements 2, -5 in the matrix $\begin{pmatrix} -1 & 0 & 5 \\ 1 & 2 & -2 \\ -4 & -5 & 3 \end{pmatrix}$ is

Options :

1. 16,3

2. 17,-3

3. 17,3

4. -17,-3

**Question Number : 3 Question Id : 61097513831 Question Type : MCQ Display Question
Number : Yes Is Question Mandatory : No Single Line Question Option : No Option
Orientation : Vertical**

The solution of the following simultaneous linear equations by using Cramer's rule $3x+4y+5z=18$:

$$2x-y+8z=13; \quad 5x-2y+7z=20 \quad \text{is}$$

Options :

1. $-3, -1, 1$

2. $3, 1, 1$

3. $3, 0, 1$

4. $3, 1, -1$

**Question Number : 4 Question Id : 61097513832 Question Type : MCQ Display Question
Number : Yes Is Question Mandatory : No Single Line Question Option : No Option
Orientation : Vertical**

If $A = \begin{pmatrix} 0 & 4 & -2 \\ -4 & 0 & 8 \\ 2 & -8 & x \end{pmatrix}$ is a skew symmetric matrix then the value of x is

Options :

1. 1

2. -8

3. -4

4. 0

Question Number : 5 Question Id : 61097513833 Question Type : MCQ Display Question

Number : Yes Is Question Mandatory : No Single Line Question Option : No Option

Orientation : Vertical

The adjoint of the matrix $A = \begin{pmatrix} 1 & 3 & 3 \\ 1 & 4 & 3 \\ 1 & 3 & 4 \end{pmatrix}$ is

Options :

1. $\begin{pmatrix} 0 & 4 & -2 \\ 4 & -2 & 8 \\ 2 & -8 & 0 \end{pmatrix}$

2. $\begin{pmatrix} 7 & -3 & -3 \\ -1 & 1 & 0 \\ -1 & 0 & 1 \end{pmatrix}$

3. $\begin{pmatrix} 7 & 3 & 3 \\ 1 & 1 & 0 \\ 1 & 0 & 1 \end{pmatrix}$

4. $\begin{pmatrix} 5 & 4 & 2 \\ 4 & 2 & 8 \\ 2 & -8 & 0 \end{pmatrix}$

Question Number : 6 Question Id : 61097513834 Question Type : MCQ Display Question

Number : Yes Is Question Mandatory : No Single Line Question Option : No Option

Orientation : Vertical

Resolve the rational function $\frac{5x+1}{(x+2)(x-1)}$ into partial fractions

Options :

1. $\frac{3}{x+2} + \frac{2}{x-1}$

2. $\frac{3}{x+2} - \frac{2}{x-1}$

3. $\frac{-3}{x+2} + \frac{2}{x-1}$

4. $\frac{3}{x-2} + \frac{2}{x+1}$

Question Number : 7 Question Id : 61097513835 Question Type : MCQ Display Question Number : Yes Is Question Mandatory : No Single Line Question Option : No Option Orientation : Vertical

Resolve the rational function $\frac{x^2}{(x^2+1)^2}$ into partial fractions

Options :

1. $\frac{x}{x^2+1} + \frac{x}{(x^2+1)^2}$

2. $\frac{x}{x^2-1} - \frac{x}{(x^2+1)^2}$

3. $\frac{x}{x^2+1} - \frac{x}{(x^2-1)^2}$

4. $\frac{x}{x^2+1} - \frac{x}{(x^2+1)^2}$

Question Number : 8 Question Id : 61097513836 Question Type : MCQ Display Question Number : Yes Is Question Mandatory : No Single Line Question Option : No Option Orientation : Vertical

Suppose that A, B, C are positive and $A + B + C = 90^\circ$ then the value of $\sum \tan A \tan B$ is

Options :

1. -1

2. -2

3. 1

4. 3

Question Number : 9 Question Id : 61097513837 Question Type : MCQ Display Question

Number : Yes Is Question Mandatory : No Single Line Question Option : No Option

Orientation : Vertical

The value of $\cos 100^\circ \cos 40^\circ + \sin 100^\circ \sin 40^\circ$ is

Options :

1. $\frac{1}{2}$

2. $-\frac{1}{2}$

3. $\frac{1}{4}$

4. $\frac{1}{8}$

Question Number : 10 Question Id : 61097513838 Question Type : MCQ Display Question

Number : Yes Is Question Mandatory : No Single Line Question Option : No Option

Orientation : Vertical

If $\frac{\cos\alpha}{a} = \frac{\sin\alpha}{b}$ then the value of $a\cos 2\alpha + b\sin 2\alpha$ is

Options :

1. $-a$

2. b

3. a

4. $-a$

Question Number : 11 Question Id : 61097513839 Question Type : MCQ Display Question

Number : Yes Is Question Mandatory : No Single Line Question Option : No Option

Orientation : Vertical

If $x + \frac{1}{x} = 2\cos\theta$ then the value of $x^3 + \frac{1}{x^3}$ is

Options :

1. $2\cos 3\theta$

2. $2\cos 2\theta$

3. $3\cos 3\theta$

4. $2\sin 3\theta$

Question Number : 12 Question Id : 61097513840 Question Type : MCQ Display Question

Number : Yes Is Question Mandatory : No Single Line Question Option : No Option

Orientation : Vertical

If $\sin x + \sin y = \frac{1}{4}$ and $\cos x + \cos y = \frac{1}{3}$ then the value of $\tan\left(\frac{x+y}{2}\right)$ is

Options :

1. $-\frac{3}{4}$

2. $\frac{5}{4}$

3. $\frac{7}{4}$

4. $\frac{3}{4}$

Question Number : 13 Question Id : 61097513841 Question Type : MCQ Display Question

Number : Yes Is Question Mandatory : No Single Line Question Option : No Option

Orientation : Vertical

The general solution for $\sqrt{3}\cos\theta = \sin\theta$ is

Options :

1. $-n\pi + \frac{\pi}{3}$

2. $n\pi + \frac{\pi}{3}$

3. $n\pi - \frac{\pi}{3}$

4. $n\pi + \frac{2\pi}{3}$

Question Number : 14 Question Id : 61097513842 Question Type : MCQ Display Question

Number : Yes Is Question Mandatory : No Single Line Question Option : No Option

Orientation : Vertical

The common solution for $\cos\theta = -\frac{1}{\sqrt{2}}$, $\tan\theta = -1$ is

Options :

1. $n\pi + \frac{2\pi}{3}$

2. $2n\pi + \frac{5\pi}{3}$

3. $5n\pi + \frac{\pi}{3}$

4. $2n\pi + \frac{3\pi}{4}$

Question Number : 15 Question Id : 61097513843 Question Type : MCQ Display Question

Number : Yes Is Question Mandatory : No Single Line Question Option : No Option

Orientation : Vertical

If x is an acute angle and $\sin(x + 10^\circ) = \cos(3x - 68^\circ)$ then the value of x is

Options :

1. -37°

2. 37°

3. 38°

4. 10°

Question Number : 16 Question Id : 61097513844 Question Type : MCQ Display Question

Number : Yes Is Question Mandatory : No Single Line Question Option : No Option

Orientation : Vertical

The value of $\tan^{-1}(2) + \tan^{-1}(3)$ is

Options :

1. $\frac{3\pi}{4}$

2. $\frac{3\pi}{5}$

3. $\frac{5\pi}{4}$

4. $\frac{\pi}{4}$

Question Number : 17 Question Id : 61097513845 Question Type : MCQ Display Question

Number : Yes Is Question Mandatory : No Single Line Question Option : No Option

Orientation : Vertical

The value of $\cos \left[\sin^{-1} \left(\frac{1}{2} \right) + \cos^{-1} \left(-\frac{\sqrt{3}}{2} \right) \right]$ is

Options :

1. 0

2. 1

3. 3

4. -1

Question Number : 18 Question Id : 61097513846 Question Type : MCQ Display Question Number : Yes Is Question Mandatory : No Single Line Question Option : No Option Orientation : Vertical

The modulus of the complex number $(-1 - \sqrt{3}i)$ is

Options :

1. 1

2. 6

3. 2

4. 4

Question Number : 19 Question Id : 61097513847 Question Type : MCQ Display Question Number : Yes Is Question Mandatory : No Single Line Question Option : No Option Orientation : Vertical

The value of $\left(\frac{\sqrt{3}}{2} + \frac{i}{2}\right)^5 - \left(\frac{\sqrt{3}}{2} - \frac{i}{2}\right)^5$ is

Options :

1. i

2. $-i$

3. $2i$

4. $-3i$

Question Number : 20 Question Id : 61097513848 Question Type : MCQ Display Question Number : Yes Is Question Mandatory : No Single Line Question Option : No Option Orientation : Vertical

The radius of the circle of the equation $x^2 + y^2 - 4x - 8y - 41 = 0$ is

Options :

1. $\sqrt{31}$

2. $\sqrt{41}$

3. $\sqrt{71}$

4. $\sqrt{61}$

Question Number : 21 Question Id : 61097513849 Question Type : MCQ Display Question Number : Yes Is Question Mandatory : No Single Line Question Option : No Option Orientation : Vertical

If the line $2y = 5 + kx$ is a tangent to the parabola $y^2 = 6x$ then the value of k is

Options :

1. $\frac{2}{5}$

2.

$\frac{3}{5}$

3. $\frac{6}{5}$

4. $\frac{7}{5}$

Ans : no correct option

Question Number : 22 Question Id : 61097513850 Question Type : MCQ Display Question

Number : Yes Is Question Mandatory : No Single Line Question Option : No Option

Orientation : Vertical

The length of latus rectum of the ellipse $9x^2 + 16y^2 = 144$ is

Options :

1. $\frac{7}{2}$

2. $\frac{9}{2}$

3. $\frac{3}{2}$

4. $\frac{5}{2}$

Question Number : 23 Question Id : 61097513851 Question Type : MCQ Display Question

Number : Yes Is Question Mandatory : No Single Line Question Option : No Option

Orientation : Vertical

The centre of the hyperbola $4x^2 - 5y^2 - 16x + 10y + 31 = 0$ is

Options :

1. (2,1)
2. (3,1)
3. (-2,1)
4. (2, -1)

Question Number : 24 Question Id : 61097513852 Question Type : MCQ Display Question Number : Yes Is Question Mandatory : No Single Line Question Option : No Option Orientation : Vertical

The angle between two tangents drawn from the point (1,4) to the parabola $y^2 = 12x$ is

Options :

1. $\tan^{-1}(2)$
2. $\tan^{-1}(3)$
3. $\tan^{-1}(5)$
4. $\tan^{-1}\left(\frac{1}{2}\right)$

Question Number : 25 Question Id : 61097513853 Question Type : MCQ Display Question Number : Yes Is Question Mandatory : No Single Line Question Option : No Option Orientation : Vertical

The length of the tangent from (1,3) to the circle $x^2 + y^2 - 2x + 4y - 11 = 0$ is

Options :

1. -3

2. 3

3. 5

4. 4

Question Number : 26 Question Id : 61097513854 Question Type : MCQ Display Question

Number : Yes Is Question Mandatory : No Single Line Question Option : No Option

Orientation : Vertical

The value of $\lim_{x \rightarrow 0} \left(\frac{\sqrt{1+x}-1}{x} \right)$ is

Options :

1. $\frac{1}{3}$

2. $-\frac{1}{3}$

3. $\frac{1}{5}$

4. $\frac{1}{2}$

Question Number : 27 Question Id : 61097513855 Question Type : MCQ Display Question

Number : Yes Is Question Mandatory : No Single Line Question Option : No Option

Orientation : Vertical

The derivative of $f(x) = \frac{a-x}{a+x}$ ($x \neq -a$) is

Options :

1. $\frac{-2a}{(a+x)^2}$

2. $\frac{2a}{(a+x)^2}$

3. $\frac{-2a}{(a-x)^2}$

4. $\frac{2a}{(a-x)^2}$

Question Number : 28 Question Id : 61097513856 Question Type : MCQ Display Question

Number : Yes Is Question Mandatory : No Single Line Question Option : No Option

Orientation : Vertical

If $x = a \left[\cos t + \log \left(\tan \frac{t}{2} \right) \right]$, $y = a \sin t$ then $\frac{dy}{dx}$ is

Options :

1. $-\tan t$

2. $\tan t$

3. $\tan t + \sin t$

4. $\sin t$

Question Number : 29 Question Id : 61097513857 Question Type : MCQ Display Question Number : Yes Is Question Mandatory : No Single Line Question Option : No Option Orientation : Vertical

If an error of 3% occurs in measuring the side of a cube then the percentage error in its volume is

Options :

1. -9

2. 7

3. 8

4. 9

Question Number : 30 Question Id : 61097513858 Question Type : MCQ Display Question Number : Yes Is Question Mandatory : No Single Line Question Option : No Option Orientation : Vertical

The slope of the tangent to the curve $y = 5x^2$ at the point $x = -1$ is

Options :

1. 10

2. 7

3. -10

4. -9

Question Number : 31 Question Id : 61097513859 Question Type : MCQ Display Question Number : Yes Is Question Mandatory : No Single Line Question Option : No Option Orientation : Vertical

The angle between the curves $xy = 2$ and $x^2 + 4y = 0$ is

Options :

1. $-\tan^{-1}(3)$

2. $\tan^{-1}(3)$

3. $\sin^{-1}(3)$

4. $\cos^{-1}(3)$

Question Number : 32 Question Id : 61097513860 Question Type : MCQ Display Question Number : Yes Is Question Mandatory : No Single Line Question Option : No Option Orientation : Vertical

For all values of a and b , $f(x) = x^3 + 3ax^2 + 3a^2x + 3a^3 + b$ is

Options :

1. Increasing only

2. Decreasing only

3. Increasing and Decreasing

4. maximum

Question Number : 33 Question Id : 61097513861 Question Type : MCQ Display Question

Number : Yes Is Question Mandatory : No Single Line Question Option : No Option

Orientation : Vertical

The minimum value of $f(x) = 4x^2 - 4x + 11$ for any x in R is

Options :

1. -10 at $x = \frac{1}{2}$

2. 10 at $x = -\frac{1}{2}$

3. 8 at $x = \frac{1}{2}$

4. 10 at $x = \frac{1}{2}$

Question Number : 34 Question Id : 61097513862 Question Type : MCQ Display Question

Number : Yes Is Question Mandatory : No Single Line Question Option : No Option

Orientation : Vertical

If $z = \log(\tan x + \tan y)$ then $(\sin 2x) \frac{\partial z}{\partial x} + (\sin 2y) \frac{\partial z}{\partial y}$ is

Options :

1. 2

2. -2

3. 4

4. 6

Question Number : 35 Question Id : 61097513863 Question Type : MCQ Display Question

Number : Yes Is Question Mandatory : No Single Line Question Option : No Option

Orientation : Vertical

If $u = \tan^{-1}\left(\frac{x^3+y^3}{x+y}\right)$ then $x \frac{\partial u}{\partial x} + y \frac{\partial u}{\partial y}$ is

Options :

1. $-\frac{1}{2} \sin 2u$

2. $-\frac{1}{2} \cos 2u$

3. $\frac{1}{2} \sin 2u$

4. $\frac{1}{2} \tan 2u$

Ans : no correct option

Question Number : 36 Question Id : 61097513864 Question Type : MCQ Display Question

Number : Yes Is Question Mandatory : No Single Line Question Option : No Option

Orientation : Vertical

The value of $\int \sin^2 x \, dx$ on R is

Options :

1. $\frac{x}{2} + \frac{\sin 2x}{4} + c$

2. $\frac{x}{2} - \frac{\sin 3x}{4} + c$

3. $\frac{x}{2} - \frac{\cos 2x}{4} + c$

4. $\frac{x}{2} - \frac{\sin 2x}{4} + c$

Question Number : 37 Question Id : 61097513865 Question Type : MCQ Display Question

Number : Yes Is Question Mandatory : No Single Line Question Option : No Option

Orientation : Vertical

The value of $\int x\sqrt{x} dx$ on $(0, \infty)$ is

Options :

1. $\frac{2}{5}x^{5/2} + c$

2. $-\frac{2}{5}x^{5/2} + c$

3. $\frac{2}{5}x^{-5/2} + c$

4. $\frac{2}{3}x^{3/2} + c$

Question Number : 38 Question Id : 61097513866 Question Type : MCQ Display Question

Number : Yes Is Question Mandatory : No Single Line Question Option : No Option

Orientation : Vertical

The value of $\int_0^2 \sqrt{4-x^2} dx$ is

Options :

1.

$$\frac{\pi}{2}$$

2. $-\frac{\pi}{2}$

3. π

4. $-\pi$

**Question Number : 39 Question Id : 61097513867 Question Type : MCQ Display Question
Number : Yes Is Question Mandatory : No Single Line Question Option : No Option
Orientation : Vertical**

The value of $\int_{\pi/6}^{\pi/3} \frac{\sqrt{\sin x}}{\sqrt{\sin x} + \sqrt{\cos x}} dx$ is

Options :

1. $\frac{\pi}{2}$

2. $\frac{\pi}{12}$

3. $-\frac{\pi}{12}$

4. π

**Question Number : 40 Question Id : 61097513868 Question Type : MCQ Display Question
Number : Yes Is Question Mandatory : No Single Line Question Option : No Option**

Orientation : Vertical

The area enclosed by the curves $y = 3x$ and $y = 6x - x^2$ in square units is

Options :

1. $\frac{7}{2}$

2. $\frac{5}{2}$

3. $\frac{3}{2}$

4. $\frac{9}{2}$

Question Number : 41 Question Id : 61097513869 Question Type : MCQ Display Question

Number : Yes Is Question Mandatory : No Single Line Question Option : No Option

Orientation : Vertical

The value of $\int \frac{e^x(1+x)}{(2+x)^2} dx$ on $I \in R \setminus \{-2\}$ is

Options :

1. $\frac{e^x}{2+x} + C$

2. $-\frac{e^x}{2+x} + C$

3. $\frac{e^x}{2-x} + C$

4. $\frac{e^{2x}}{2+x} + C$

Question Number : 42 Question Id : 61097513870 Question Type : MCQ Display Question

Number : Yes Is Question Mandatory : No Single Line Question Option : No Option

Orientation : Vertical

The value of $\int \frac{1}{1+4x^2} dx$ on \mathbb{R} is

Options :

1. $-\frac{1}{2} \tan^{-1}(2x) + c$

2. $\frac{1}{2} \tan^{-1}(5x) + c$

3. $-\frac{1}{2} \tan^{-1}(x) + c$

4. $\frac{1}{2} \tan^{-1}(2x) + c$

Question Number : 43 Question Id : 61097513871 Question Type : MCQ Display Question

Number : Yes Is Question Mandatory : No Single Line Question Option : No Option

Orientation : Vertical

The value of $\int \frac{2x^2-5x+1}{x^2(x^2-1)} dx$ is

Options :

1. $\frac{1}{x} + \log \left| \frac{x^5}{(x^2-1)(x+1)^3} \right| + C$

2. $\frac{1}{x} - \log \left| \frac{x^5}{(x^2-1)(x+1)^3} \right| + C$

3. $\frac{1}{x} + \log \left| \frac{x^5}{(x^2+1)(x+1)^3} \right| + C$

4. $\frac{1}{x} - \log \left| \frac{x^5}{(x^2+1)(x+1)^3} \right| + C$

Question Number : 44 Question Id : 61097513872 Question Type : MCQ Display Question

Number : Yes Is Question Mandatory : No Single Line Question Option : No Option

Orientation : Vertical

The solution of $\frac{dy}{dx} = \frac{x-2y+1}{2x-4y}$ is

Options :

1. $(x + 2y)^2 + 2x = c$

2. $(x - 2y)^2 - 2x = c$

3. $(x - 2y)^2 + 2x = c$

4. $(x - 4y)^2 + 2x = c$

Question Number : 45 Question Id : 61097513873 Question Type : MCQ Display Question

Number : Yes Is Question Mandatory : No Single Line Question Option : No Option

Orientation : Vertical

The solution of the homogeneous differential equation $xy^2 dy - (x^3 + y^3) dx = 0$ is

Options :

1. $y^3 = -3x^3 \log(xc)$

2. $y^3 = 3x^3 \log(x/c)$

3. $y^3 = 3x^3 \log(x^2c)$

4. $y^3 = 3x^3 \log(xc)$

Question Number : 46 Question Id : 61097513874 Question Type : MCQ Display Question

Number : Yes Is Question Mandatory : No Single Line Question Option : No Option

Orientation : Vertical

The solution of the linear differential equation $\frac{dy}{dx} + y \cot x = \cos x$ is

Options :

1. $y - \sin x = -\frac{\cos 2x}{4} + c$

2. $y/\sin x = -\frac{\cos 2x}{4} + c$

3. $y \sin x = -\frac{\cos 2x}{4} + c$

4. $y \sin x = \frac{\cos 2x}{4} + c$

Question Number : 47 Question Id : 61097513875 Question Type : MCQ Display Question

Number : Yes Is Question Mandatory : No Single Line Question Option : No Option

Orientation : Vertical

The solution of Bernoulli's equation $x^3 \frac{dy}{dx} - x^2 y = -y^4 \cos x$ is

Options :

1. $\frac{x^2}{y^2} = 3 \sin x + c$

2. $\frac{x^2}{y^2} = -3 \sin x + c$

3. $\frac{x^2}{y^2} = 3 \sin x^3 + c$

4. $\frac{x^4}{y^4} = 3 \sin x + c$

Question Number : 48 Question Id : 61097513876 Question Type : MCQ Display Question

Number : Yes Is Question Mandatory : No Single Line Question Option : No Option

Orientation : Vertical

The particular integral for the differential equation $(D^2 + 3D + 2)y = 12x^2$ is

Options :

1. $6x^2 + 18x - 21$

2. $6x^2 - 18x + 21$

3. $-6x^2 + 18x - 21$

4. $6x^2 + 18x + 21$

Question Number : 49 Question Id : 61097513877 Question Type : MCQ Display Question
Number : Yes Is Question Mandatory : No Single Line Question Option : No Option
Orientation : Vertical

The particular integral for the differential equation $6\frac{d^2y}{dx^2} + 17\frac{dy}{dx} + 12y = e^{-x}$ is

Options :

1. $-e^{-x}$

2. e^x

3. e^{-2x}

4. e^{-x}

Question Number : 50 Question Id : 61097513878 Question Type : MCQ Display Question
Number : Yes Is Question Mandatory : No Single Line Question Option : No Option
Orientation : Vertical

The particular integral for the differential equation $(D^2 - 4D + 13)y = \cos 2x$ is

Options :

1. $\frac{1}{145}(9 \cos 2x - 8 \sin 2x)$

2. $\frac{1}{145}(9 \cos 2x + 8 \sin 2x)$

3. $\frac{1}{145}(-9 \cos 2x - 8 \sin 2x)$

4. $\frac{1}{135}(9 \cos 2x - 8 \sin 2x)$

Physics

Section Number :	2
Mandatory or Optional :	Mandatory
Number of Questions :	25
Number of Questions to be attempted :	25
Section Marks :	25
Display Number Panel :	Yes
Group All Questions :	Yes
Mark As Answered Required? :	Yes

Question Number : 51 Question Id : 61097513879 Question Type : MCQ Display Question

Number : Yes Is Question Mandatory : No Single Line Question Option : No Option

Orientation : Vertical

Young's modulus of steel is $2 \times 10^{11} \text{ N m}^{-2}$. Its value in dyne cm^{-2} is

Options :

1. 2×10^{12}

2. 2×10^{10}

3. 2×10^8

4. 2×10^{-11}

Question Number : 52 Question Id : 61097513880 Question Type : MCQ Display Question

Number : Yes Is Question Mandatory : No Single Line Question Option : No Option

Orientation : Vertical

Dimension of velocity gradient is

Options :

1. $[M^0L^0T^{-1}]$

2. $[ML^{-1}T^{-1}]$

3. $[M^0LT^{-1}]$

4. $[ML^0T^{-1}]$

Question Number : 53 Question Id : 61097513881 Question Type : MCQ Display Question

Number : Yes Is Question Mandatory : No Single Line Question Option : No Option

Orientation : Vertical

Unit vector parallel to the resultant of vectors $A = 4\hat{i} - 3\hat{j}$ and $B = 8\hat{i} + 8\hat{j}$ will be

Options :

1. $\frac{24\hat{i}+5\hat{j}}{13}$

2. $\frac{12\hat{i}+5\hat{j}}{13}$

3. $\frac{6i+5j}{13}$

4. $\frac{12i-5j}{13}$

Question Number : 54 Question Id : 61097513882 Question Type : MCQ Display Question Number : Yes Is Question Mandatory : No Single Line Question Option : No Option Orientation : Vertical

The resultant of two forces $3P$ and $2P$ is R . If the first force is doubled, then the resultant is also doubled. The angle between the two forces is

Options :

1. 60°

2. 120°

3. 30°

4. 135°

Question Number : 55 Question Id : 61097513883 Question Type : MCQ Display Question Number : Yes Is Question Mandatory : No Single Line Question Option : No Option Orientation : Vertical

A particle is projected vertically upward with a speed of 40 m/s , then the velocity of the particle 2 seconds before it reaches the maximum height is (Take $g = 10 \text{ m/s}^2$)

Options :

1.

20 m s²

2. 4.2 m s²

3. 9.8 m s²

4. 10 m s²

Question Number : 56 Question Id : 61097513884 Question Type : MCQ Display Question Number : Yes Is Question Mandatory : No Single Line Question Option : No Option

Orientation : Vertical

A car moving with constant acceleration covered the distance between two points 60 m apart in 6 s. Its speed as it passes the second point was 15 m s. The acceleration is

Options :

1. $\frac{1}{3} \text{ ms}^{-2}$

2. $\frac{2}{3} \text{ ms}^{-2}$

3. $\frac{3}{5} \text{ ms}^{-2}$

4. $\frac{5}{3} \text{ ms}^{-2}$

Question Number : 57 Question Id : 61097513885 Question Type : MCQ Display Question

Number : Yes Is Question Mandatory : No Single Line Question Option : No Option

Orientation : Vertical

A stone is thrown vertically upwards. When stone is at half of its maximum height, its speed is 10 ms^{-1} ; then the maximum height attained by the stone is ($g=10 \text{ m s}^{-2}$)

Options :

1. 25m

2. 10m

3. 15m

4. 20m

Question Number : 58 Question Id : 61097513886 Question Type : MCQ Display Question

Number : Yes Is Question Mandatory : No Single Line Question Option : No Option

Orientation : Vertical

Identify the correct statement.

Options :

1. Static friction depends on the area of contact.

2. Kinetic friction depends on the area of contact.

3. Coefficient of static friction does not depend on the area of the surface in contact.

4. Coefficient of kinetic friction is less than the coefficient of static friction.

Question Number : 59 Question Id : 61097513887 Question Type : MCQ Display Question Number : Yes Is Question Mandatory : No Single Line Question Option : No Option

Orientation : Vertical

The coefficient of friction between the tyres and the road is 0.25. The maximum speed with which a car can be driven round a curve of radius 40 m without skidding is (assume $g=10\text{m s}^{-2}$)

Options :

1. 40 ms^{-1}

2. 20 ms^{-1}

3. 15 ms^{-1}

4. 10 ms^{-1}

Question Number : 60 Question Id : 61097513888 Question Type : MCQ Display Question Number : Yes Is Question Mandatory : No Single Line Question Option : No Option

Orientation : Vertical

During a projectile motion, if the maximum height is equal to the horizontal range, then the angle of projection with the horizontal is

Options :

1. $\tan^{-1}(1)$

2. $\tan^{-1}(2)$

3. $\tan^{-1}(4)$

4. $\tan^{-1}(3)$

Question Number : 61 Question Id : 61097513889 Question Type : MCQ Display Question Number : Yes Is Question Mandatory : No Single Line Question Option : No Option Orientation : Vertical

The potential energy of a certain spring when stretched through a distance S is 10 joule. The amount of work (in joule) that must be done on this spring to stretch it through additional distance S will be

Options :

1. 30

2. 40

3. 10

4. 20

Question Number : 62 Question Id : 61097513890 Question Type : MCQ Display Question Number : Yes Is Question Mandatory : No Single Line Question Option : No Option Orientation : Vertical

A machine gun fires six bullets per second into a target. The mass of each bullet is 3 g and the speed is 500 m/s. The power delivered to the bullets is

Options :

1. 1.5 kW

2. 2.25 kW

3. 0.75 kW

4. 375 kW

Question Number : 63 Question Id : 61097513891 Question Type : MCQ Display Question

Number : Yes Is Question Mandatory : No Single Line Question Option : No Option

Orientation : Vertical

Which of the following is the cheapest renewable energy ?

Options :

1. Solar energy

2. Wind energy

3. Hydel energy

4. Nuclear energy

Question Number : 64 Question Id : 61097513892 Question Type : MCQ Display Question

Number : Yes Is Question Mandatory : No Single Line Question Option : No Option

Orientation : Vertical

The maximum velocity of particle executing simple harmonic motion with an amplitude of 7 mm is 4.4 m/s. The time period of oscillation is

Options :

1. 100 s

2. 10 s

3. 0.1 s

4. 0.01 s

Question Number : 65 Question Id : 61097513893 Question Type : MCQ Display Question Number : Yes Is Question Mandatory : No Single Line Question Option : No Option Orientation : Vertical

Two waves of lengths 50 cm and 51 cm produced 12 beats per second. The velocity of sound is

Options :

1. 340 m/s

2. 331 m/s

3. 306 m/s

4. 360 m/s

Question Number : 66 Question Id : 61097513894 Question Type : MCQ Display Question Number : Yes Is Question Mandatory : No Single Line Question Option : No Option Orientation : Vertical

The apparent frequency of the whistle of an engine changes in the ratio 9:8 as the engine passes a stationary observer. If the velocity of the sound is 340 ms^{-1} , then the velocity of the engine is

Options :

1. 40 m/s

2. 20 m/s

3. 340 m/s

4. 180 m/s

Question Number : 67 Question Id : 61097513895 Question Type : MCQ Display Question

Number : Yes Is Question Mandatory : No Single Line Question Option : No Option

Orientation : Vertical

Quality of sound is decided by

Options :

1. loudness

2. intensity

3. number of overtones

4. frequency

Question Number : 68 Question Id : 61097513896 Question Type : MCQ Display Question

Number : Yes Is Question Mandatory : No Single Line Question Option : No Option

Orientation : Vertical

Inaudibility limit is

Options :

1. one hundredth of initial intensity

2. one tenth of initial intensity
3. one thousandth of initial intensity
4. one millionth of initial intensity

Question Number : 69 Question Id : 61097513897 Question Type : MCQ Display Question

Number : Yes Is Question Mandatory : No Single Line Question Option : No Option

Orientation : Vertical

A Carnot's engine operates with source at 127°C and sink at 27°C . If the source supplies 40 kJ of heat energy, the work done by the engine is

Options :

1. 30 kJ
2. 10 kJ
3. 4 kJ
4. 1 kJ

Question Number : 70 Question Id : 61097513898 Question Type : MCQ Display Question

Number : Yes Is Question Mandatory : No Single Line Question Option : No Option

Orientation : Vertical

A monoatomic gas initially at 17°C is suddenly compressed to one eighth of its original volume. The temperature after compression is

Options :

1. 1160K
2. 36.25K
3. 2320K
4. 887K

Question Number : 71 Question Id : 61097513899 Question Type : MCQ Display Question

Number : Yes Is Question Mandatory : No Single Line Question Option : No Option

Orientation : Vertical

Two cylinders of volumes 20 cc and 30 cc have gases at pressures 40 cm and 50 cm of Hg under the same temperature. If they are connected by a very narrow pipe the pressure in cm of Hg will be

Options :

1. 45
2. 50
3. 46
4. 15

Question Number : 72 Question Id : 61097513900 Question Type : MCQ Display Question

Number : Yes Is Question Mandatory : No Single Line Question Option : No Option

Orientation : Vertical

In an adiabatic expansion, a gas does 25J of work while in an adiabatic compression 100J of work is done on a gas. The change of internal energy in the two processes respectively are

Options :

1. 25J and -100J
2. - 25J and 100J
3. -25J and -100J
4. 25J and 100J

Question Number : 73 Question Id : 61097513901 Question Type : MCQ Display Question

Number : Yes Is Question Mandatory : No Single Line Question Option : No Option

Orientation : Vertical

The volume of one mole of an ideal gas changes from V to $2V$ at temperature of 300 K. If R is universal gas constant, then work done in this process is

Options :

1. $300R\ln 2$
2. $600R\ln 2$
3. $300\ln 2$
4. $600\ln 2$

Question Number : 74 Question Id : 61097513902 Question Type : MCQ Display Question

Number : Yes Is Question Mandatory : No Single Line Question Option : No Option

Orientation : Vertical

The maximum kinetic energy of the photoelectrons emitted from a surface is dependent on the

Options :

1. intensity of incident radiation
2. potential of the collector electrode
3. frequency of incident radiation
4. angle of incident of radiation of the surface

Question Number : 75 Question Id : 61097513903 Question Type : MCQ Display Question

Number : Yes Is Question Mandatory : No Single Line Question Option : No Option

Orientation : Vertical

In an optical fibre, relation between refractive index of core (n_1) and refractive index of cladding (n_2) is

Options :

1. $n_1 > n_2$
2. $n_1 < n_2$
3. $n_1 = n_2$
4. $n_1 \ll n_2$

Chemistry

Section Number :	3
Mandatory or Optional :	Mandatory
Number of Questions :	25
Number of Questions to be attempted :	25
Section Marks :	25
Display Number Panel :	Yes
Group All Questions :	Yes
Mark As Answered Required? :	Yes

Question Number : 76 Question Id : 61097513904 Question Type : MCQ Display Question

Number : Yes Is Question Mandatory : No Single Line Question Option : No Option

Orientation : Vertical

The nucleus consists of

Options :

1. Proton and electron
2. Proton and Neutron
3. Proton and Duterium
4. Proton and photan

Question Number : 77 Question Id : 61097513905 Question Type : MCQ Display Question

Number : Yes Is Question Mandatory : No Single Line Question Option : No Option

Orientation : Vertical

The shape of P-Orbital is

Options :

1. Spherical

2. Dumbbell
3. Double Dumbbell
4. Oval

Question Number : 78 Question Id : 61097513906 Question Type : MCQ Display Question Number : Yes Is Question Mandatory : No Single Line Question Option : No Option Orientation : Vertical

The maximum number of electrons that a f-orbital can accommodate is

Options :

1. 2
2. 6
3. 10
4. 14

Question Number : 79 Question Id : 61097513907 Question Type : MCQ Display Question Number : Yes Is Question Mandatory : No Single Line Question Option : No Option Orientation : Vertical

In NaCl formation Sodium is donating ----- electrons

Options :

1. 0

2. 2

3. 1

4. 3

Question Number : 80 Question Id : 61097513908 Question Type : MCQ Display Question Number : Yes Is Question Mandatory : No Single Line Question Option : No Option Orientation : Vertical

O₂ molecule contains

Options :

1. Covalent bond

2. Ionic bond

3. Hydrogen bond

4. Metallic bond

Question Number : 81 Question Id : 61097513909 Question Type : MCQ Display Question Number : Yes Is Question Mandatory : No Single Line Question Option : No Option Orientation : Vertical

Avagadro Number is

Options :

1. 6.023×10^{-23}

2. 6.023×10^{23}

3. 60.23×10^{23}

4. 6.023×10^{25}

Question Number : 82 Question Id : 61097513910 Question Type : MCQ Display Question

Number : Yes Is Question Mandatory : No Single Line Question Option : No Option

Orientation : Vertical

The normality of the solution obtained by dissolving 8 gm of NaOH in 1 Litre is

Options :

1. 2N

2. 0.2N

3. 0.25N

4. 0.02N

Question Number : 83 Question Id : 61097513911 Question Type : MCQ Display Question

Number : Yes Is Question Mandatory : No Single Line Question Option : No Option

Orientation : Vertical

Molecular weight of MgSO_4 is

Options :

1. 120

2. 121

3. 119

4. 122

Question Number : 84 Question Id : 61097513912 Question Type : MCQ Display Question Number : Yes Is Question Mandatory : No Single Line Question Option : No Option Orientation : Vertical

A Lewis base is a substance which

Options :

1. Accept protons
2. Accept a lone pair of electrons
3. Donate protons
4. Donate a lone pair of electrons

Question Number : 85 Question Id : 61097513913 Question Type : MCQ Display Question Number : Yes Is Question Mandatory : No Single Line Question Option : No Option Orientation : Vertical

pH of a solution is 4.5, the solution is

Options :

1. Basic
2. Acidic

3. Neutral

4. Amphoteric

Question Number : 86 Question Id : 61097513914 Question Type : MCQ Display Question Number : Yes Is Question Mandatory : No Single Line Question Option : No Option Orientation : Vertical

One Faraday is equal to

Options :

1. 96485 C

2. 98485 C

3. 96465 C

4. 96585 C

Question Number : 87 Question Id : 61097513915 Question Type : MCQ Display Question Number : Yes Is Question Mandatory : No Single Line Question Option : No Option Orientation : Vertical

Common electrolyte used in the salt bridge is

Options :

1. NaOH

2. NaCl

3. KCl

4. KOH

Question Number : 88 Question Id : 61097513916 Question Type : MCQ Display Question Number : Yes Is Question Mandatory : No Single Line Question Option : No Option Orientation : Vertical

SI Units of Electrical conductivity are

Options :

1. Seimens per meter

2. Seimens per centimeter

3. Seimens per millimeter

4. Seimens per kilometer

Question Number : 89 Question Id : 61097513917 Question Type : MCQ Display Question Number : Yes Is Question Mandatory : No Single Line Question Option : No Option Orientation : Vertical

Calculate the standard e.m.f of the Zn-Cu cell, if the cell is represented as $Zn, Zn^{2+}; Cu^{2+}, Cu$ ($E^{\circ}Zn^{2+}/Zn = 0.86$ and $(E^{\circ}Cu^{2+}/Cu) = 0.34$).

Options :

1. 1.20V

2. 0.52V

3. -1.20V

4. -0.11V

Question Number : 90 Question Id : 61097513918 Question Type : MCQ Display Question Number : Yes Is Question Mandatory : No Single Line Question Option : No Option Orientation : Vertical

Permanent Hardness is caused due to

Options :

1. Carbonates and Bicarbonates
2. Carbonates and Sulphates
3. Chlorides and Sulphates
4. Chlorides and Carbonates

Question Number : 91 Question Id : 61097513919 Question Type : MCQ Display Question Number : Yes Is Question Mandatory : No Single Line Question Option : No Option Orientation : Vertical

Permutit is chemically

Options :

1. Sodium Silicate
2. Aluminium Silicate

3. Hydrated Sodium alumino silicate
4. Calcium silicate

Question Number : 92 Question Id : 61097513920 Question Type : MCQ Display Question Number : Yes Is Question Mandatory : No Single Line Question Option : No Option Orientation : Vertical

The anion exchange resin possesses

Options :

1. Acidic group
2. Basic group
3. Amphoteric group
4. Benzo group

Question Number : 93 Question Id : 61097513921 Question Type : MCQ Display Question Number : Yes Is Question Mandatory : No Single Line Question Option : No Option Orientation : Vertical

Chemically the rust is

Options :

1. Fe_2O_3
2. $\text{Fe}_2\text{O}_3, \text{FeO}$

3. $\text{Fe}_2\text{O}_3 \cdot x\text{H}_2\text{O}$

4. $\text{Fe}_2\text{O}_3 \cdot \text{NH}_3$

Question Number : 94 Question Id : 61097513922 Question Type : MCQ Display Question Number : Yes Is Question Mandatory : No Single Line Question Option : No Option Orientation : Vertical

The gradual loss of a metal by chemical or electrochemical action of environment is called

Options :

1. Corrosion

2. Caustic embrittlement

3. Priming

4. foaming

Question Number : 95 Question Id : 61097513923 Question Type : MCQ Display Question Number : Yes Is Question Mandatory : No Single Line Question Option : No Option Orientation : Vertical

Which of the following is a thermosetting plastic ?

Options :

1. Bakelite

2. Polystyrene

3. Polythene

4. Nylon

Question Number : 96 Question Id : 61097513924 Question Type : MCQ Display Question Number : Yes Is Question Mandatory : No Single Line Question Option : No Option Orientation : Vertical

Tetra Fluoro Ethane is a monomer of

Options :

1. Teflon

2. Nylon

3. Styrene

4. Rubber

Question Number : 97 Question Id : 61097513925 Question Type : MCQ Display Question Number : Yes Is Question Mandatory : No Single Line Question Option : No Option Orientation : Vertical

Buna-N is a copolymer of

Options :

1. Butadiene and Styrene

2. Butadiene and Acrylonitrile

3. Butadiene and Isoprene
4. Formaldehyde and Styrene

Question Number : 98 Question Id : 61097513926 Question Type : MCQ Display Question Number : Yes Is Question Mandatory : No Single Line Question Option : No Option Orientation : Vertical

Main constituent of Producer gas is

Options :

1. $\text{CO} + \text{N}_2$
2. $\text{CO} + \text{H}_2$
3. $\text{CO} + \text{CO}_2$
4. $\text{CO}_2 + \text{H}_2$

Question Number : 99 Question Id : 61097513927 Question Type : MCQ Display Question Number : Yes Is Question Mandatory : No Single Line Question Option : No Option Orientation : Vertical

Ozone layer is present at

Options :

1. Stratosphere
2. Inosphere
- 3.

Thermosphere

4. Atmosphere

Question Number : 100 Question Id : 61097513928 Question Type : MCQ Display Question

Number : Yes Is Question Mandatory : No Single Line Question Option : No Option

Orientation : Vertical

Acid Rain is caused due to

Options :

1. Chloro Fluoro Carbons

2. Methane

3. Oxides of Sulphur and Nitrogen

4. Carbon monoxide

Electrical and Electronics Engineering

Section Number :	4
Mandatory or Optional :	Mandatory
Number of Questions :	100
Number of Questions to be attempted :	100
Section Marks :	100
Display Number Panel :	Yes
Group All Questions :	Yes

Mark As Answered Required? :

Yes

Question Number : 101 Question Id : 61097513929 Question Type : MCQ Display Question

Number : Yes Is Question Mandatory : No Single Line Question Option : No Option

Orientation : Vertical

Which of the following statement is not correct?

Options :

1. Ohm's law is applicable to ohmic conductors only
2. KCL is derived from law of conservation of charges
3. Superposition theorem is applicable to a circuit to calculate power
4. Thevenin's voltage (V_{th}) is an open circuit voltage across the load terminals

Question Number : 102 Question Id : 61097513930 Question Type : MCQ Display Question

Number : Yes Is Question Mandatory : No Single Line Question Option : No Option

Orientation : Vertical

Two wires are made up of same mass of copper material with 2 mm and 3 mm thick.

The two wires are connected in series across a constant supply. Heat produced in the wires is in the ratio of

Options :

1. 81:16
2. 9:4
3. 2:3

4. 27:8

Question Number : 103 Question Id : 61097513931 Question Type : MCQ Display Question Number : Yes Is Question Mandatory : No Single Line Question Option : No Option Orientation : Vertical

Consider the following circuit. The current in 5 ohms resistor is _____

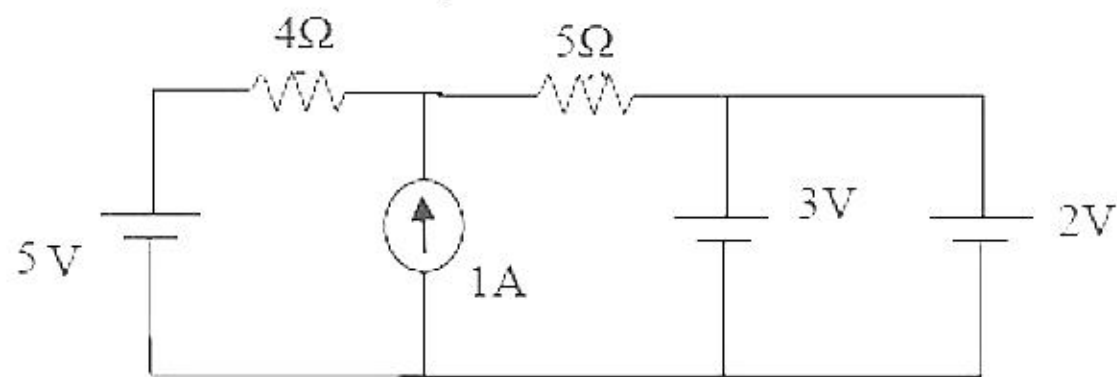

Options :

1. -1 A
2. 2 A
3. 1A
4. Circuit does not exist

Question Number : 104 Question Id : 61097513932 Question Type : MCQ Display Question Number : Yes Is Question Mandatory : No Single Line Question Option : No Option Orientation : Vertical

The efficiency of nickel-iron cell is less than the lead acid cell due to

Options :

1. smaller quantity of electrolyte used

2. lower emf
3. higher internal resistance
4. compactness

Question Number : 105 Question Id : 61097513933 Question Type : MCQ Display Question Number : Yes Is Question Mandatory : No Single Line Question Option : No Option Orientation : Vertical

The current flowing through a 2 cm long coil of 10 turns is 750 mA. The magnetizing force in AT/m is

Options :

1. 350
2. 375
3. 1500
4. 750

Question Number : 106 Question Id : 61097513934 Question Type : MCQ Display Question Number : Yes Is Question Mandatory : No Single Line Question Option : No Option Orientation : Vertical

Which of the following insulating material has affinity to moisture

Options :

1. Bakelite

2. porcelain
3. glass
4. asbestos

Question Number : 107 Question Id : 61097513935 Question Type : MCQ Display Question Number : Yes Is Question Mandatory : No Single Line Question Option : No Option Orientation : Vertical

Find the source voltage, if the voltage between CD in the following circuit is 5 V.

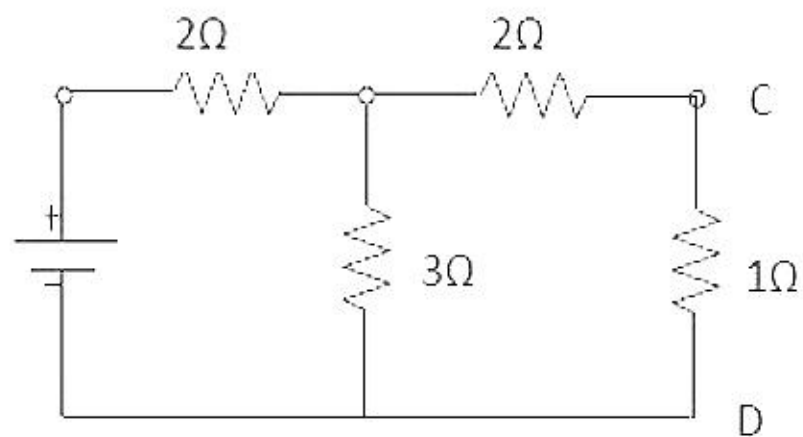

Options :

1. 15V
2. 25V
3. 35V
4. 16 V

Question Number : 108 Question Id : 61097513936 Question Type : MCQ Display Question Number : Yes Is Question Mandatory : No Single Line Question Option : No Option Orientation : Vertical

If the number of conductors and speed of a Lap wound D.C. Generator is doubled then the generated e.m.f. will be _____

Options :

1. Remains the same
2. Double the former value
3. Eight times the former value
4. Four times the former value

Question Number : 109 Question Id : 61097513937 Question Type : MCQ Display Question

Number : Yes Is Question Mandatory : No Single Line Question Option : No Option

Orientation : Vertical

Copper brushes in D.C. machine are used

Options :

1. where low voltage and high currents are involved
2. where high voltage and small currents are involved
3. where low voltage and low currents are involved
4. where high voltage and high currents are involved

Question Number : 110 Question Id : 61097513938 Question Type : MCQ Display Question

Number : Yes Is Question Mandatory : No Single Line Question Option : No Option

Orientation : Vertical

The e.m.f. induced in the armature of a shunt generator is 600 V. The armature resistance is 0.1 ohm. If the armature current is 200 A, the terminal voltage will be

Options :

1. 640 V
2. 620 V
3. 600 V
4. 580 V

Question Number : 111 Question Id : 61097513939 Question Type : MCQ Display Question

Number : Yes Is Question Mandatory : No Single Line Question Option : No Option

Orientation : Vertical

Two generators A and B have 6-poles each. Generator A has wave wound armature while generator B has lap wound armature. The ratio of the induced e.m.f.'s of generator A and B will be

Options :

1. 2:3
2. 3:1
3. 3:2
4. 1:3

Question Number : 112 Question Id : 61097513940 Question Type : MCQ Display Question

Number : Yes Is Question Mandatory : No Single Line Question Option : No Option

Orientation : Vertical

A D.C. series motor is that which

Options :

1. has its field winding consisting of thick wire and less turns
2. has a poor torque
3. can be started easily without load
4. has almost constant speed

Question Number : 113 Question Id : 61097513941 Question Type : MCQ Display Question

Number : Yes Is Question Mandatory : No Single Line Question Option : No Option

Orientation : Vertical

In case of D.C. shunt motors the speed is dependent on back e.m.f. only because

Options :

1. back e.m.f. is equal to armature drop
2. armature drop is negligible
3. flux is proportional to armature current
4. flux is practically constant in D.C. shunt motors

Question Number : 114 Question Id : 61097513942 Question Type : MCQ Display Question

Number : Yes Is Question Mandatory : No Single Line Question Option : No Option

Orientation : Vertical

In a D.C. series motor, if the armature current is reduced by 50%, the torque of the motor will be equal to

Options :

1. 100% of the previous value
2. 25% of the previous value
3. 50% of the previous value
4. 10% of the previous value

Question Number : 115 Question Id : 61097513943 Question Type : MCQ Display Question

Number : Yes Is Question Mandatory : No Single Line Question Option : No Option

Orientation : Vertical

Which of the following method of speed control of D.C. machine will offer minimum efficiency?

Options :

1. Voltage control method
2. Field control method
3. Armature control method
4. Ward-Leonard method

Question Number : 116 Question Id : 61097513944 Question Type : MCQ Display Question Number : Yes Is Question Mandatory : No Single Line Question Option : No Option Orientation : Vertical

Which of the following are integrating instruments?

Options :

1. Ammeters
2. Voltmeters
3. Wattmeters
4. Ampere-hour and watt-hour meters

Question Number : 117 Question Id : 61097513945 Question Type : MCQ Display Question Number : Yes Is Question Mandatory : No Single Line Question Option : No Option Orientation : Vertical

For handling greater currents induction wattmeter are used in conjunction with

Options :

1. Potential transformers
2. current transformers
3. power transformers
4. Resistors

Question Number : 118 Question Id : 61097513946 Question Type : MCQ Display Question

Number : Yes Is Question Mandatory : No Single Line Question Option : No Option

Orientation : Vertical

The output of thermocouple is in the range of

Options :

1. Volts
2. Millivolts
3. Amperes
4. Milliamperes

Question Number : 119 Question Id : 61097513947 Question Type : MCQ Display Question

Number : Yes Is Question Mandatory : No Single Line Question Option : No Option

Orientation : Vertical

The temperature coefficient of thermistor transducer is

Options :

1. Negative
2. Positive
3. Zero
4. Infinite

Question Number : 120 Question Id : 61097513948 Question Type : MCQ Display Question

Number : Yes Is Question Mandatory : No Single Line Question Option : No Option

Orientation : Vertical

In an AC circuit (sine wave) with R and L in series

Options :

1. Voltage across R and L 180° out of phase
2. The voltage across R lags the voltage across L by 90°
3. The voltage across R leads the voltage across L by 90°
4. Voltage across R and L are in phase

Question Number : 121 Question Id : 61097513949 Question Type : MCQ Display Question

Number : Yes Is Question Mandatory : No Single Line Question Option : No Option

Orientation : Vertical

A parallel AC circuit in resonance will

Options :

1. Have a high voltage developed across each inductive and capacitive section
2. Have high impedance
3. Act like a resistor of low value
4. Have current in each section equal to the line current

Question Number : 122 Question Id : 61097513950 Question Type : MCQ Display Question

Number : Yes Is Question Mandatory : No Single Line Question Option : No Option

Orientation : Vertical

In an RL series circuit $R = 10 \Omega$ and $X_L = 17.32 \Omega$. The phase angle in degrees between voltage and current is

Options :

1. 30
2. 45
3. 60
4. 90

Question Number : 123 Question Id : 61097513951 Question Type : MCQ Display Question

Number : Yes Is Question Mandatory : No Single Line Question Option : No Option

Orientation : Vertical

A three phase, balanced delta connected load of $25 \angle -63.4^\circ \Omega$ is connected across a 400V, 3 – ϕ balanced supply. Determine the phase current I_R .

(Assume phase sequence to be RYB)

Options :

1. $15 \angle -63.4^\circ \text{A}$
2. $25 \angle 63.4^\circ \text{A}$
3. $25 \angle -63.4^\circ \text{A}$
4. $16 \angle 63.4^\circ \text{A}$

Question Number : 124 Question Id : 61097513952 Question Type : MCQ Display Question

Number : Yes Is Question Mandatory : No Single Line Question Option : No Option

Orientation : Vertical

By using two wattmeter method, power can be measured in

Options :

1. 3 - phase, 3 - wire system
2. 3 - phase, 2 - wire system
3. 3 - phase, 4 - wire system
4. 1 - phase, 2 - wire system

Question Number : 125 Question Id : 61097513953 Question Type : MCQ Display Question

Number : Yes Is Question Mandatory : No Single Line Question Option : No Option

Orientation : Vertical

The purpose of providing iron core is to

Options :

1. Provide support to windings
2. Reduce hysteresis loss
3. Decrease reluctance of magnetic path
4. Reduce eddy current loss

Question Number : 126 Question Id : 61097513954 Question Type : MCQ Display Question

Number : Yes Is Question Mandatory : No Single Line Question Option : No Option

Orientation : Vertical

A good voltage regulation of a transformer means

Options :

1. Difference between primary and secondary voltages is more
2. Output voltage fluctuation from no load to full load is least
3. Output voltage fluctuation with power factor is least
4. Difference between primary and secondary voltages is least

Question Number : 127 Question Id : 61097513955 Question Type : MCQ Display Question

Number : Yes Is Question Mandatory : No Single Line Question Option : No Option

Orientation : Vertical

The useful flux of a 1- ϕ transformer at full load is 2 webers. At half load, the flux will be _____

Options :

1. 0.5 webers
2. 1 weber
3. 4 webers
4. 2 webers

Question Number : 128 Question Id : 61097513956 Question Type : MCQ Display Question

Number : Yes Is Question Mandatory : No Single Line Question Option : No Option

Orientation : Vertical

Why Transformers connected in parallel should have same voltage ratio?

Options :

1. To avoid no load circulating current
2. To avoid full load circulating current
3. To avoid other losses
4. To avoid all types of currents

Question Number : 129 Question Id : 61097513957 Question Type : MCQ Display Question

Number : Yes Is Question Mandatory : No Single Line Question Option : No Option

Orientation : Vertical

Breather is provided in a transformer to

Options :

1. Absorb moisture of air during breathing
2. the filter of transformer oil
3. provide cold air in the transformer
4. insulation between windings

Question Number : 130 Question Id : 61097513958 Question Type : MCQ Display Question

Number : Yes Is Question Mandatory : No Single Line Question Option : No Option

Orientation : Vertical

The efficiency of two identical transformers under load conditions can be determined by

Options :

1. Short Circuit test
2. open Circuit test
3. No Load test
4. Back to Back test

Question Number : 131 Question Id : 61097513959 Question Type : MCQ Display Question

Number : Yes Is Question Mandatory : No Single Line Question Option : No Option

Orientation : Vertical

When a two-winding transformer is connected as an auto-transformer, its efficiency _____

Options :

1. Raises to 100%
2. Increases
3. Remains the same
4. Decreases

Question Number : 132 Question Id : 61097513960 Question Type : MCQ Display Question

Number : Yes Is Question Mandatory : No Single Line Question Option : No Option

Orientation : Vertical

The main disadvantage of using short-pitch winding in alternators is that it

Options :

1. Reduces harmonics in the generated voltage
2. Reduces the total voltage around the armature coils
3. Produces asymmetry in the three phase windings
4. Increases Cu of end connections

Question Number : 133 Question Id : 61097513961 Question Type : MCQ Display Question

Number : Yes Is Question Mandatory : No Single Line Question Option : No Option

Orientation : Vertical

The full load terminal voltage of an alternator is greater than no load terminal voltage when

Options :

1. load is highly inducted
2. alternator is under excitation
3. load is highly capacitive
4. input mechanical power is increased

Question Number : 134 Question Id : 61097513962 Question Type : MCQ Display Question

Number : Yes Is Question Mandatory : No Single Line Question Option : No Option

Orientation : Vertical

If two alternators are running in parallel and the excitation of one of the alternators is increased, then

Options :

1. Power output will decrease
2. Wattless component will change
3. Both machines will start vibrating
4. Machine with excess excitation will burn

Question Number : 135 Question Id : 61097513963 Question Type : MCQ Display Question

Number : Yes Is Question Mandatory : No Single Line Question Option : No Option

Orientation : Vertical

If the field of a synchronous motor is under excited, the power factor will be

Options :

1. Lagging
2. unity
3. leading
4. >1

Question Number : 136 Question Id : 61097513964 Question Type : MCQ Display Question

Number : Yes Is Question Mandatory : No Single Line Question Option : No Option

Orientation : Vertical

A synchronous motor working at leading power factor can be used as

Options :

1. Voltage booster
2. Noise generator
3. Mechanical synchronizer
4. Phase advancer

Question Number : 137 Question Id : 61097513965 Question Type : MCQ Display Question

Number : Yes Is Question Mandatory : No Single Line Question Option : No Option

Orientation : Vertical

The effect of increasing load on a synchronous motor running with normal excitation is to

Options :

1. Increase both its I_a and p.f.
2. Decrease I_a but increase p.f.
3. Increase I_a but decrease p.f.
4. Decrease both its I_a and p.f.

Question Number : 138 Question Id : 61097513966 Question Type : MCQ Display Question

Number : Yes Is Question Mandatory : No Single Line Question Option : No Option

Orientation : Vertical

In squirrel cage induction motors, the rotor slots are given slight skew in order to

Options :

1. reduce windage losses
2. reduce eddy currents
3. reduce accumulation of dirt and dust
4. reduce magnetic hum

Question Number : 139 Question Id : 61097513967 Question Type : MCQ Display Question

Number : Yes Is Question Mandatory : No Single Line Question Option : No Option

Orientation : Vertical

A wound rotor induction motor runs with a slip of 0.03 when developing full load torque. Its rotor resistance is 0.25 ohms per phase. If an external resistance of 0.5 ohm per phase is connected across the slip rings, what is the slip for full load torque?

Options :

1. 0.03
2. 0.06
3. 0.09
4. 0.1

Question Number : 140 Question Id : 61097513968 Question Type : MCQ Display Question Number : Yes Is Question Mandatory : No Single Line Question Option : No Option Orientation : Vertical

Star-delta starting of motors is not possible in case of

Options :

1. single phase motors
2. variable speed motors
3. low horse power motors
4. high speed motors

Question Number : 141 Question Id : 61097513969 Question Type : MCQ Display Question Number : Yes Is Question Mandatory : No Single Line Question Option : No Option Orientation : Vertical

In case of a double cage induction motor, the inner cage has

Options :

1. high inductance and low resistance
2. low inductance and high resistance
3. low inductance and low resistance
4. high inductance and high resistance

Question Number : 142 Question Id : 61097513970 Question Type : MCQ Display Question Number : Yes Is Question Mandatory : No Single Line Question Option : No Option Orientation : Vertical

A single phase induction motor is not self starting because it has

Options :

1. no slip
2. Absence of rotating magnetic field
3. High inertia
4. Rotor is short circuited

Question Number : 143 Question Id : 61097513971 Question Type : MCQ Display Question Number : Yes Is Question Mandatory : No Single Line Question Option : No Option Orientation : Vertical

Which of the following will have a better power factor?

Options :

1. Capacitor start
2. Shaded pole
3. Split phase
4. Capacitor run

Question Number : 144 Question Id : 61097513972 Question Type : MCQ Display Question

Number : Yes Is Question Mandatory : No Single Line Question Option : No Option

Orientation : Vertical

The effect of water hammer can be minimized by using

Options :

1. Anvil
2. Spill way
3. Surge tank
4. Draft tube

Question Number : 145 Question Id : 61097513973 Question Type : MCQ Display Question

Number : Yes Is Question Mandatory : No Single Line Question Option : No Option

Orientation : Vertical

If load factor and diversity factor increases, the cost of units generated

Options :

1. decreases
2. Increases
3. Remains same
4. insufficient data

Question Number : 146 Question Id : 61097513974 Question Type : MCQ Display Question

Number : Yes Is Question Mandatory : No Single Line Question Option : No Option

Orientation : Vertical

In _____ tariff the total energy consumed is divided into blocks.

Options :

1. Flat rate
2. Block rate
3. Two part
4. Maximum demand

Question Number : 147 Question Id : 61097513975 Question Type : MCQ Display Question

Number : Yes Is Question Mandatory : No Single Line Question Option : No Option

Orientation : Vertical

The shielding of nuclear reactor is made of

Options :

1. Heavy water
2. Uranium
3. Cadmium
4. Cement concrete

Question Number : 148 Question Id : 61097513976 Question Type : MCQ Display Question

Number : Yes Is Question Mandatory : No Single Line Question Option : No Option

Orientation : Vertical

One of the drawbacks of low power factor is

Options :

1. Decreases number of units consumed
2. Decreases the efficiency of the system
3. Improvement in voltage regulation
4. Reduction in overall cost per unit

Question Number : 149 Question Id : 61097513977 Question Type : MCQ Display Question

Number : Yes Is Question Mandatory : No Single Line Question Option : No Option

Orientation : Vertical

Mho relay is normally used for protection of

Options :

1. Short transmission lines
2. Medium transmission lines
3. Long transmission lines
4. No length Criterion

Question Number : 150 Question Id : 61097513978 Question Type : MCQ Display Question

Number : Yes Is Question Mandatory : No Single Line Question Option : No Option

Orientation : Vertical

_____ relay is an instantaneous relay.

Options :

1. Induction disc type
2. Balanced beam type
3. Hinged armature type
4. Polarized type

Question Number : 151 Question Id : 61097513979 Question Type : MCQ Display Question

Number : Yes Is Question Mandatory : No Single Line Question Option : No Option

Orientation : Vertical

For protection of parallel feeders fed at one end, the relays required are

Options :

1. Directional relays at both ends
2. Non-directional relays at both ends
3. Non-directional relay at source end and directional relay at load end
4. Directional relay at source end and non-directional relay at load end

Question Number : 152 Question Id : 61097513980 Question Type : MCQ Display Question

Number : Yes Is Question Mandatory : No Single Line Question Option : No Option

Orientation : Vertical

The transient voltage that appears across the contacts at the instant of arc extinction is called

Options :

1. supply voltage
2. peak voltage
3. recovery voltage
4. re-striking voltage

Question Number : 153 Question Id : 61097513981 Question Type : MCQ Display Question

Number : Yes Is Question Mandatory : No Single Line Question Option : No Option

Orientation : Vertical

In a lightning arrester ____ impedance path exists between the line and ground _____.

Options :

1. Infinite. always
2. low. before the over voltage
3. High. before the over voltage
4. low. at the instant of over voltage

Question Number : 154 Question Id : 61097513982 Question Type : MCQ Display Question

Number : Yes Is Question Mandatory : No Single Line Question Option : No Option

Orientation : Vertical

If the spacing between the conductors of a line is increased, the inductance _____ and the Capacitance _____

Options :

1. Increases , decreases
2. Increases , increases
3. Decreases , decreases
4. Decreases , increases

Question Number : 155 Question Id : 61097513983 Question Type : MCQ Display Question

Number : Yes Is Question Mandatory : No Single Line Question Option : No Option

Orientation : Vertical

Under no-load condition, the current in a transmission line is due to

Options :

1. Corona effect
2. Inductance of the line
3. Capacitance of the line
4. back flow from the earth

Question Number : 156 Question Id : 61097513984 Question Type : MCQ Display Question

Number : Yes Is Question Mandatory : No Single Line Question Option : No Option

Orientation : Vertical

Corona loss increases with _____

Options :

1. Increase in conductor size and decrease in supply frequency
2. Decrease in conductor size and increase in supply frequency
3. Increase in both conductor size and supply frequency
4. Decrease in both conductor size and supply frequency

Question Number : 157 Question Id : 61097513985 Question Type : MCQ Display Question

Number : Yes Is Question Mandatory : No Single Line Question Option : No Option

Orientation : Vertical

Skin effect is proportional to

Options :

1. (Conductor diameter)³
2. (Conductor diameter)^{1/2}
3. (Conductor diameter)⁴
4. (Conductor diameter)²

Question Number : 158 Question Id : 61097513986 Question Type : MCQ Display Question

Number : Yes Is Question Mandatory : No Single Line Question Option : No Option

Orientation : Vertical

If the sag in an over head line decreases, tension in the line

Options :

1. Decreases
2. remains the same
3. Increases
4. will become zero

Question Number : 159 Question Id : 61097513987 Question Type : MCQ Display Question

Number : Yes Is Question Mandatory : No Single Line Question Option : No Option

Orientation : Vertical

Transmission line insulators are made of _____

Options :

1. Glass
2. Iron
3. P.V.C
4. Porcelain

Question Number : 160 Question Id : 61097513988 Question Type : MCQ Display Question

Number : Yes Is Question Mandatory : No Single Line Question Option : No Option

Orientation : Vertical

Which is the first equipment seen in the substation while coming from transmission system?

Options :

1. Lightning arrester
2. Circuit breaker
3. Current transformer
4. Potential transformer

Question Number : 161 Question Id : 61097513989 Question Type : MCQ Display Question

Number : Yes Is Question Mandatory : No Single Line Question Option : No Option

Orientation : Vertical

Metallic sheath in cables is used to protect the cable from

Options :

1. Metallic corrosion
2. corrosion
3. Mechanical injuries
4. chemicals

Question Number : 162 Question Id : 61097513990 Question Type : MCQ Display Question

Number : Yes Is Question Mandatory : No Single Line Question Option : No Option

Orientation : Vertical

Ring system is preferred over radial system because

Options :

1. Less cost
2. Reliable & less voltage drop
3. Voltage can be reduced
4. poor voltage regulation

Question Number : 163 Question Id : 61097513991 Question Type : MCQ Display Question

Number : Yes Is Question Mandatory : No Single Line Question Option : No Option

Orientation : Vertical

Which of the following is not true regarding HVDC?

Options :

1. There is no distance limit for HVDC under ground line
2. HVDC link can operate between two AC systems whose frequencies are equal
3. Corona loss is much more in HVDC transmission
4. The power transmission of bipolar line is same as that of single circuit ac line

Question Number : 164 Question Id : 61097513992 Question Type : MCQ Display Question

Number : Yes Is Question Mandatory : No Single Line Question Option : No Option

Orientation : Vertical

Suburban railways use

Options :

1. 600 to 750 V DC
2. 3000 V DC
3. 3.3 K V 3- Φ AC
4. 1100V 1- ϕ AC

Question Number : 165 Question Id : 61097513993 Question Type : MCQ Display Question

Number : Yes Is Question Mandatory : No Single Line Question Option : No Option

Orientation : Vertical

Quadrilateral speed-time curve pertains to which of the following service?

Options :

1. Main line service
2. Suburban service only
3. Urban service only
4. Urban and Suburban service

Question Number : 166 Question Id : 61097513994 Question Type : MCQ Display Question

Number : Yes Is Question Mandatory : No Single Line Question Option : No Option

Orientation : Vertical

The free-running speed of a train does not depend on the

Options :

1. Running time
2. Duration of stops
3. Acceleration
4. Distance between stops

Question Number : 167 Question Id : 61097513995 Question Type : MCQ Display Question

Number : Yes Is Question Mandatory : No Single Line Question Option : No Option

Orientation : Vertical

The specific energy consumption for suburban services is usually

Options :

1. 18 to 25 watt-hours per tonne km
2. 125 to 150 watt-hours per tonne km
3. 50 to 75 watt-hours per tonne km
4. 155 to 200 watt-hours per tonne km

Question Number : 168 Question Id : 61097513996 Question Type : MCQ Display Question

Number : Yes Is Question Mandatory : No Single Line Question Option : No Option

Orientation : Vertical

Which of the following happens in Kando system?

Options :

1. 1- ϕ AC is converted into 3- ϕ AC
2. 1- ϕ AC is converted into DC
3. 3- ϕ AC is converted into DC
4. 3- ϕ AC is converted into 1- ϕ AC

Question Number : 169 Question Id : 61097513997 Question Type : MCQ Display Question

Number : Yes Is Question Mandatory : No Single Line Question Option : No Option

Orientation : Vertical

Longer coasting period for a train results in _____

Options :

1. Higher schedule speed
2. Higher retardation
3. Higher acceleration
4. Lower specific energy consumption

Question Number : 170 Question Id : 61097513998 Question Type : MCQ Display Question

Number : Yes Is Question Mandatory : No Single Line Question Option : No Option

Orientation : Vertical

The friction at the track is proportional to

Options :

1. $\frac{1}{speed}$
2. $speed^2$
3. $speed$
4. $\frac{1}{speed^2}$

Question Number : 171 Question Id : 61097513999 Question Type : MCQ Display Question

Number : Yes Is Question Mandatory : No Single Line Question Option : No Option

Orientation : Vertical

Which one of the following factor affects specific energy consumption of a train?

Options :

1. Gradient
2. distance between stops
3. minimum speed
4. maximum speed

Question Number : 172 Question Id : 61097514000 Question Type : MCQ Display Question

Number : Yes Is Question Mandatory : No Single Line Question Option : No Option

Orientation : Vertical

_____ wiring system provides best protection against fire.

Options :

1. Wooden casing
2. Cleat wiring
3. Metal conduit wiring
4. Capping wiring

Question Number : 173 Question Id : 61097514001 Question Type : MCQ Display Question

Number : Yes Is Question Mandatory : No Single Line Question Option : No Option

Orientation : Vertical

_____ wiring is recommended only for temporary installations.

Options :

1. Cleat
2. CTS RTS
3. Metal
4. PVC capping

Question Number : 174 Question Id : 61097514002 Question Type : MCQ Display Question

Number : Yes Is Question Mandatory : No Single Line Question Option : No Option

Orientation : Vertical

Which of the following is least preferred for earthing?

Options :

1. Clayey soil
2. Dry earth
3. Wet mashy earth
4. earth mixed with salt

Question Number : 175 Question Id : 61097514003 Question Type : MCQ Display Question

Number : Yes Is Question Mandatory : No Single Line Question Option : No Option

Orientation : Vertical

What should be the value of earthing resistance for large power stations?

Options :

1. 1 ohm
2. 0.5 ohm
3. 2 ohm
4. 5 ohm

Question Number : 176 Question Id : 61097514004 Question Type : MCQ Display Question

Number : Yes Is Question Mandatory : No Single Line Question Option : No Option

Orientation : Vertical

In a break down region, a zener diode behaves like a _____ source.

Options :

1. Constant current
2. Constant voltage
3. Constant resistance
4. Constant capacitance

Question Number : 177 Question Id : 61097514005 Question Type : MCQ Display Question

Number : Yes Is Question Mandatory : No Single Line Question Option : No Option

Orientation : Vertical

For a half or full wave rectifier, the peak inverse voltage is always

Options :

1. Greater than the input voltage
2. Equal to the input voltage
3. Smaller than the input voltage
4. Greater than the input voltage for full wave rectifier and smaller for half wave rectifier

Question Number : 178 Question Id : 61097514006 Question Type : MCQ Display Question

Number : Yes Is Question Mandatory : No Single Line Question Option : No Option

Orientation : Vertical

An LED and phototransistor is equivalent to a an

Options :

1. opto coupler
2. FET
3. Regulator
4. Thermocouple

Question Number : 179 Question Id : 61097514007 Question Type : MCQ Display Question

Number : Yes Is Question Mandatory : No Single Line Question Option : No Option

Orientation : Vertical

The unwanted characteristics of amplifier output apart from the desired output is collectively termed as _____

Options :

1. Inefficiency
2. Damage
3. Fault
4. Distortion

Question Number : 180 Question Id : 61097514008 Question Type : MCQ Display Question

Number : Yes Is Question Mandatory : No Single Line Question Option : No Option

Orientation : Vertical

If three cascaded amplifiers have gains 10, 20 and 30, the overall gain will be

Options :

1. 60

2. 6000

3. 600

4. 6

Question Number : 181 Question Id : 61097514009 Question Type : MCQ Display Question

Number : Yes Is Question Mandatory : No Single Line Question Option : No Option

Orientation : Vertical

The frequency of oscillations of Colpitt's oscillator ω_0 is given by

Options :

1. $\sqrt{\frac{C_1+C_2}{C_1C_2L}}$

2. $\sqrt{\frac{C_1C_2}{(C_1+C_2)L}}$

3. $\sqrt{\frac{C_1+C_2L}{C_1C_2}}$

4. $\sqrt{\frac{C_1}{C_2L}}$

Question Number : 182 Question Id : 61097514010 Question Type : MCQ Display Question

Number : Yes Is Question Mandatory : No Single Line Question Option : No Option

Orientation : Vertical

An LC oscillator cannot be used to produce _____ frequencies

Options :

1. High
2. Audio
3. Very high
4. Very low

Question Number : 183 Question Id : 61097514011 Question Type : MCQ Display Question

Number : Yes Is Question Mandatory : No Single Line Question Option : No Option

Orientation : Vertical

The sum of two octal numbers 75_8 and 256_8 is

Options :

1. 331_8
2. 353_8
3. 352_8

4. 341s

Question Number : 184 Question Id : 61097514012 Question Type : MCQ Display Question Number : Yes Is Question Mandatory : No Single Line Question Option : No Option Orientation : Vertical

The AND gate can be constructed with two _____ gates.

Options :

1. NAND
2. EX-OR
3. NOR
4. EX-NOR

Question Number : 185 Question Id : 61097514013 Question Type : MCQ Display Question Number : Yes Is Question Mandatory : No Single Line Question Option : No Option Orientation : Vertical

As compared to MOS memories, bipolar memories are

Options :

1. Slower access time but are cheaper
2. Slower access time and are costly
3. Faster access time and are cheaper

4. Faster access time and are costly

Question Number : 186 Question Id : 61097514014 Question Type : MCQ Display Question Number : Yes Is Question Mandatory : No Single Line Question Option : No Option Orientation : Vertical

An 8-bit counter type ADC operates on 1 MHz clock. Its average conversion time is

Options :

1. 0.258 ms
2. 1.028 μ s
3. 0.128 ms
4. 128 ns

Question Number : 187 Question Id : 61097514015 Question Type : MCQ Display Question Number : Yes Is Question Mandatory : No Single Line Question Option : No Option Orientation : Vertical

During forward blocking state a thyristor is associated with

Options :

1. Large current, low voltage
2. low current, large voltage
3. Large current, large voltage

4. medium current, low voltage

Question Number : 188 Question Id : 61097514016 Question Type : MCQ Display Question

Number : Yes Is Question Mandatory : No Single Line Question Option : No Option

Orientation : Vertical

The VI characteristics of UJT is

Options :

1. Similar to CE with a linear and saturation region
2. Similar to FET with a linear and pinch off region
3. Similar to tunnel diode in some respects
4. Similar to PN junction diode in some respects

Question Number : 189 Question Id : 61097514017 Question Type : MCQ Display Question

Number : Yes Is Question Mandatory : No Single Line Question Option : No Option

Orientation : Vertical

UJT when used for triggering an SCR, has the waveform

Options :

1. Sine wave
2. Sawtooth wave
3. Square Wave

4. Trapezoidal

Question Number : 190 Question Id : 61097514018 Question Type : MCQ Display Question Number : Yes Is Question Mandatory : No Single Line Question Option : No Option Orientation : Vertical

The object of connecting resistance and capacitance across gate circuit is to protect SCR gate against

Options :

1. Noise signals
2. Over voltages
3. Over currents
4. dv/dt

Question Number : 191 Question Id : 61097514019 Question Type : MCQ Display Question Number : Yes Is Question Mandatory : No Single Line Question Option : No Option Orientation : Vertical

In a 3- ϕ full converter the six SCRs are fired at an interval of

Options :

1. 120°
2. 30°
3. 60°

4. 45°

Question Number : 192 Question Id : 61097514020 Question Type : MCQ Display Question Number : Yes Is Question Mandatory : No Single Line Question Option : No Option Orientation : Vertical

For a full bridge inverter with the following load: $R = 2 \Omega$, $X_L = 8 \Omega$ and $X_C = 6 \Omega$

Options :

1. The output voltage lags the current by 45°
2. The output current lags the voltage by 45°
3. The output current lags the voltage by 90°
4. The output current lags the voltage by more than 90°

Question Number : 193 Question Id : 61097514021 Question Type : MCQ Display Question Number : Yes Is Question Mandatory : No Single Line Question Option : No Option Orientation : Vertical

The principle of three phase cycloconverter is to

Options :

1. add and remove number of SCRs
2. keep the firing angle as 0° for all the devices
3. vary progressively the firing angle of the devices

4. keep the firing angle as 180° for all the devices

Question Number : 194 Question Id : 61097514022 Question Type : MCQ Display Question Number : Yes Is Question Mandatory : No Single Line Question Option : No Option Orientation : Vertical

The d.c. motor terminal voltage supplied by a solid-state chopper for speed control purposes varies.....with the duty ratio of the chopper.

Options :

1. inversely
2. parabolical
3. indirectly
4. linearly

Question Number : 195 Question Id : 61097514023 Question Type : MCQ Display Question Number : Yes Is Question Mandatory : No Single Line Question Option : No Option Orientation : Vertical

SMPS are based on the _____ principle.

Options :

1. Phase control
2. Chopper
3. MOSFET

4. Integral control

Question Number : 196 Question Id : 61097514024 Question Type : MCQ Display Question Number : Yes Is Question Mandatory : No Single Line Question Option : No Option Orientation : Vertical

_____ is used in the rotating type UPS system to supply the mains.

Options :

1. Alternator
2. Self excited DC generator
3. DC motor
4. Battery bank

Question Number : 197 Question Id : 61097514025 Question Type : MCQ Display Question Number : Yes Is Question Mandatory : No Single Line Question Option : No Option Orientation : Vertical

The 8051 has _____ parallel I/O Ports.

Options :

1. 4
2. 3
3. 5

4. ²

Question Number : 198 Question Id : 61097514026 Question Type : MCQ Display Question Number : Yes Is Question Mandatory : No Single Line Question Option : No Option Orientation : Vertical

What does the symbol '#' represent in the instruction MOV A, #55H ?

Options :

1. Indexed data type
2. Indirect data type
3. Direct data type
4. Immediate data type

Question Number : 199 Question Id : 61097514027 Question Type : MCQ Display Question Number : Yes Is Question Mandatory : No Single Line Question Option : No Option Orientation : Vertical

How does the microcontroller communicate with the external peripherals memory?

Options :

1. Via registers only
2. Via I/O Ports

3. Via memory

4. Via counter

Question Number : 200 Question Id : 61097514028 Question Type : MCQ Display Question Number : Yes Is Question Mandatory : No Single Line Question Option : No Option Orientation : Vertical

Which instruction moves an accumulator to the register from the below mentioned mnemonics?

Options :

1. MOV A, R_n

2. MOV direct, A

3. MOV R_n, A

4. MOV A, @R_i